

ITEM NO.	PART NUMBER	DESCRIPTION	QTY.
1	CDB-00-0012	SPRING FOR SPRING HOSE KIT	1
2	FA13015	1/4"-20 x 3" GRADE 5 ZINC HEX CAP SCREW	2
3	FA14673	1-1/2"-6 x 5" GRADE 8 PLAIN FINISH HEX CAP SCREW	4
4	FA15465	1"-8 x 3" GRADE 8 YELLOW ZINC HEX CAP SCREW	16
5	FA17983	1"-14 x 3" GRADE 8 YELLOW ZINC HEX CAP SCREW	1
6	FA37286	1-1/2"-6 GRADE C ZINC FINISH STEEL COLLAR STYLE TOP LOCK NUT	4
7	FA60102	DynaFlo[REG] 1/8"-27 STRAIGHT STEEL ZINC GREASE FITTING WITH BALL CHECK	1
8	FA0166995	1"-8 GRADE F ZINC FINISH STEEL FLANGE TOP LOCK NUT	16
9	HD-00-124	SPINDLE NUT	2
10	HD-00-125	LOCK WASHER	1
11	HD-00-126	BACKING PLATE	1
12	HD-00-146	SHAFT REINFORCEMENT	1
13	HD-02-004	Upper & Lower Jaws	1
14	HD-02-007	BASE WELDMENT	1
15	P-BS-64450	TAPERED ROLLER BEARING 64450	2
16	P-BS-64700	TAPERED ROLLER BEARING RACE 64700	2
17	P-MP-EZS0024	6" x 12.5" x 2.5" CYLINDER	2
18	P-MP-EZS0030	4" x 8" x 1.5" CYLINDER WITH CHECK VALVE	2
19	P-PS-VA-0860-03-1	MAIN SELECTOR VALVE	1

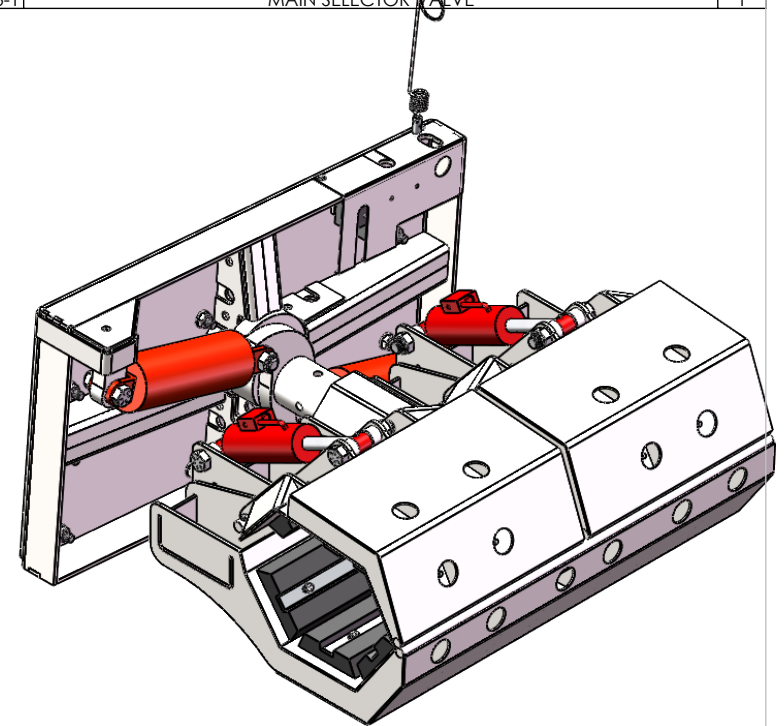

UNLESS OTHERWISE SPECIFIED:		NAME	DATE
DIMENSIONS ARE IN INCHES	DRAWN	BEVAN	3/25/2020
TOLERANCES:	CHECKED		
FRACTIONAL ±	ENG APPR.		
ANGULAR: MACH ± BEND ±	MFG APPR.		
TWO PLACE DECIMAL ±	Q.A.		
THREE PLACE DECIMAL ±	COMMENTS:		
INTERPRET GEOMETRIC TOLERANCING PER:			
MATERIAL			
FINISH			
NEXT ASSY	USED ON		
APPLICATION	DO NOT SCALE DRAWING		

EZ-SPOT-UR

TITLE:
POLE CLAW WELDMENT

SIZE DWG. NO. REV
A HD-02-006J - EXTREME POLE SETTER WITH REGULAR UPPER INSERTS

SCALE: 1:22 WEIGHT: 3180.04 LBS SHEET 1 OF 1

PROPRIETARY AND CONFIDENTIAL

THE INFORMATION CONTAINED IN THIS DRAWING IS THE SOLE PROPERTY OF EZ-SPOT-UR. ANY REPRODUCTION IN PART OR AS A WHOLE WITHOUT THE WRITTEN PERMISSION OF EZ-SPOT-UR IS PROHIBITED.