

ITEM NO.	PART NUMBER	DESCRIPTION	QTY.
1	EZ-01-0001	STANDARD BASE	1
2	FA11197-01206	3/4" DIA 6-1/4"L STEEL HITCH PIN	1
3	HDW-00-0035	COTTER PIN	1
4	RR-01-0001	ROOT PICK	1

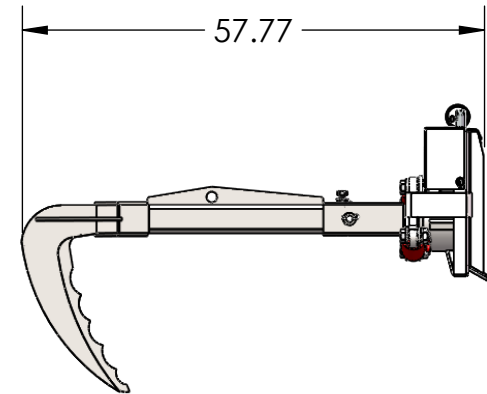
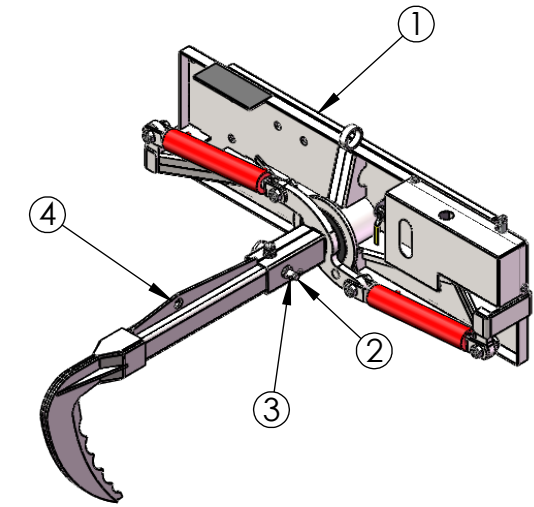
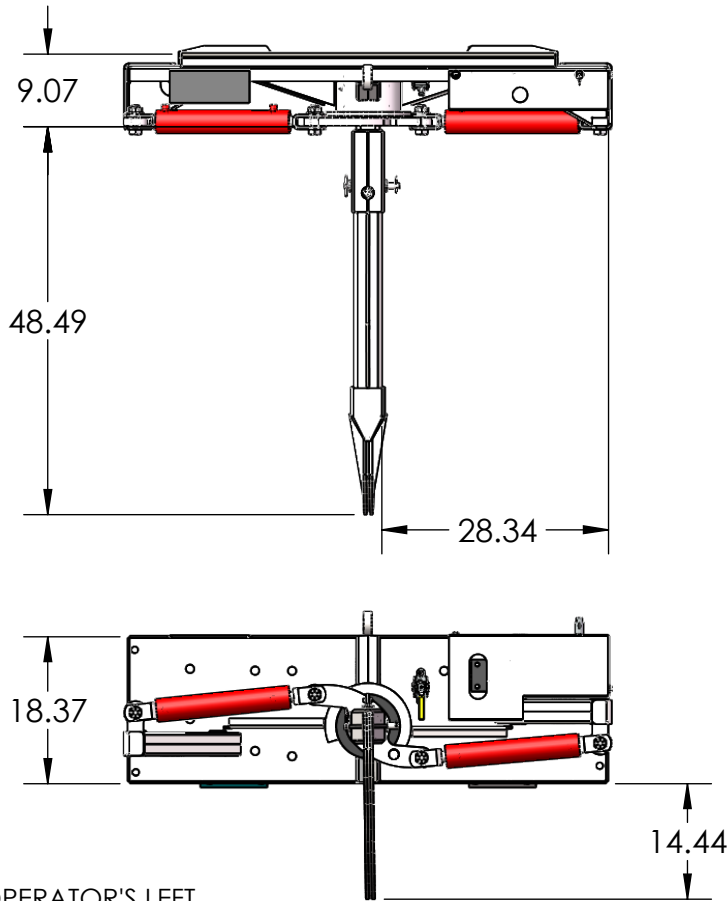

ROTATES 127° TO OPERATOR'S LEFT

WEIGHT= 503 LBS

UNLESS OTHERWISE SPECIFIED:

DIMENSIONS ARE IN INCHES
TOLERANCES:
FRACTIONAL ±
ANGULAR: MACH ± BEND ±
TWO PLACE DECIMAL ±
THREE PLACE DECIMAL ±

INTERPRET GEOMETRIC
TOLERANCING PER:

MATERIAL

FINISH

DO NOT SCALE DRAWING

	NAME	DATE
DRAWN	BEVAN	11-28-12
CHECKED		
ENG APPR.		
MFG APPR.		
Q.A.		

COMMENTS:

EZ-SPOT-UR

TITLE:

**ROOT PICK WITH
STANDARD BASE**

SIZE	DWG. NO.	REV
A	RR-01-0002 - ROOT PICK & STANDARD BASE	A
SCALE: 1:24	WT: 521.26 LBS	SHEET 1 OF 2

REVISIONS			
REV.	DESCRIPTION	DATE	APPROVED
A	ADDED THE BILL OF MATERIALS	11/13/2019	BEVAN

PROPRIETARY AND CONFIDENTIAL

THE INFORMATION CONTAINED IN THIS DRAWING IS THE SOLE PROPERTY OF EZ-SPOT-UR. ANY REPRODUCTION IN PART OR AS A WHOLE WITHOUT THE WRITTEN PERMISSION OF EZ-SPOT-UR IS PROHIBITED.

NEXT ASSY

USED ON

APPLICATION

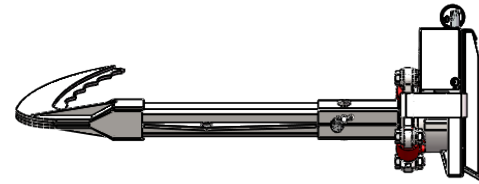
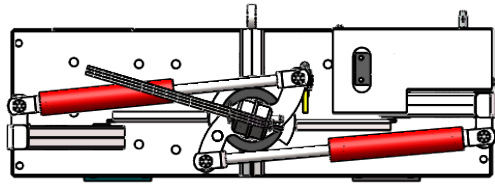
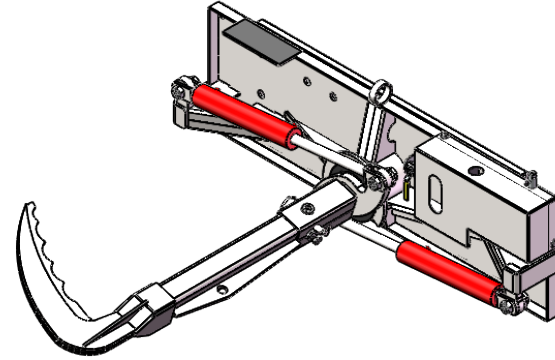
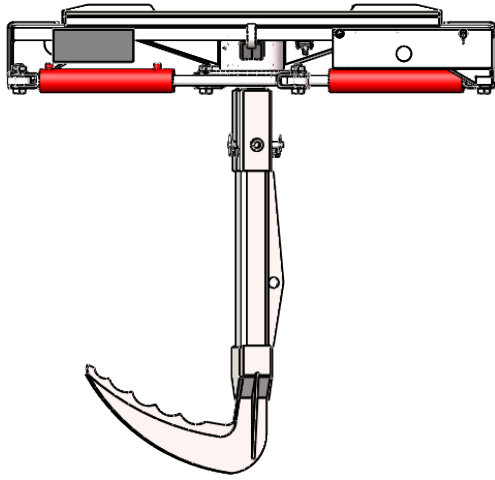

PROPRIETARY AND CONFIDENTIAL

THE INFORMATION CONTAINED IN THIS DRAWING IS THE SOLE PROPERTY OF EZ-SPOT-UR. ANY REPRODUCTION IN PART OR AS A WHOLE WITHOUT THE WRITTEN PERMISSION OF EZ-SPOT-UR IS PROHIBITED.

		UNLESS OTHERWISE SPECIFIED:		NAME	DATE	EZ-SPOT-UR	
		DIMENSIONS ARE IN INCHES TOLERANCES: FRACTIONAL ± ANGULAR: MACH ± BEND ± TWO PLACE DECIMAL ± THREE PLACE DECIMAL ±		DRAWN	BEVAN		
		INTERPRET GEOMETRIC TOLERANCING PER:		CHECKED			TITLE:
		MATERIAL		ENG APPR.			ROOT PICK WITH STANDARD BASE
		FINISH		MFG APPR.			SIZE
NEXT ASSY	USED ON			Q.A.			DWG. NO.
APPLICATION		DO NOT SCALE DRAWING		COMMENTS:			RR-01-0002 - ROOT PICK & STANDARD BASE
							REV
							A
							SCALE: 1:24 WT: 521.26 LBS SHEET 2 OF 2