

REVISIONS			
REV.	DESCRIPTION	DATE	APPROVED
A	UPDATED DIMENSIONS AFTER UPDATING THE RACKING	6/13/2016	BEVAN
B	MOVED TOOL AREA TO TOP OF RACK	6/16/2016	BEVAN
C	UPDATED DIMENSIONS	6/21/2016	BEVAN
D	MOVED THE PALLET FORKS ON TOP OF RACK	6/27/2016	BEVAN
E	ADDED CHOCK COMPARTMENT	7/7/2016	BEVAN
F	ADDED LATCHES FOR THE MINI POLE JACK AND AUGER	8/15/2016	BEVAN
G	ADDED DOORS	9/1/2017	BEVAN
H	REMOVED PALLET FORK AND FLOW CONTROL BUCKET	10/31/2017	BEVAN
J	REMOVED TR-01-033	11/1/2017	BEVAN
K	MOVED DOORS UP 1" TO CLEAR THE TIE-DOWN RINGS	4/18/2018	BEVAN
L	CHANGED TOOL BOX LENGTH FROM 77" TO 93" SO IT GOES ACROSS THE ENTIRE RACK	2/27/2019	BEVAN
M	UPDATED ANGLE & POSITION OF AUGER HOLDER	8/2/2019	BEVAN
N	MOVED AUGER HOLDER ALL THE WAY OVER TO SIDE	8/2/2019	BEVAN

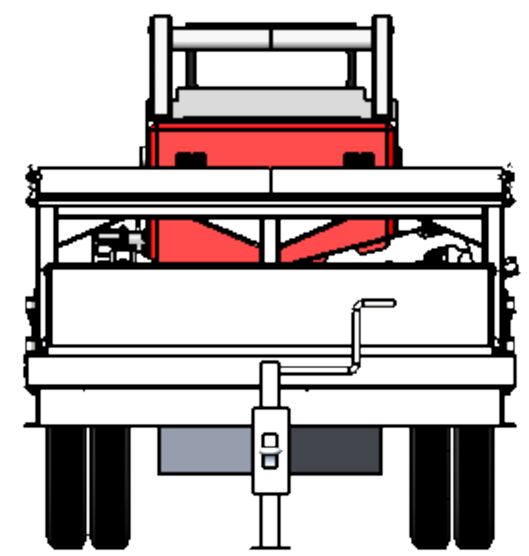
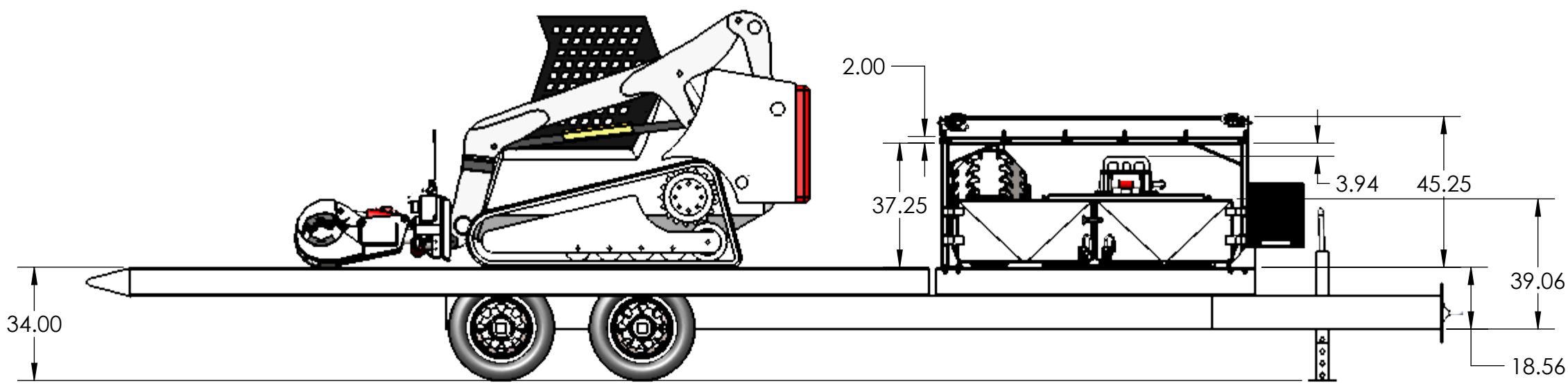
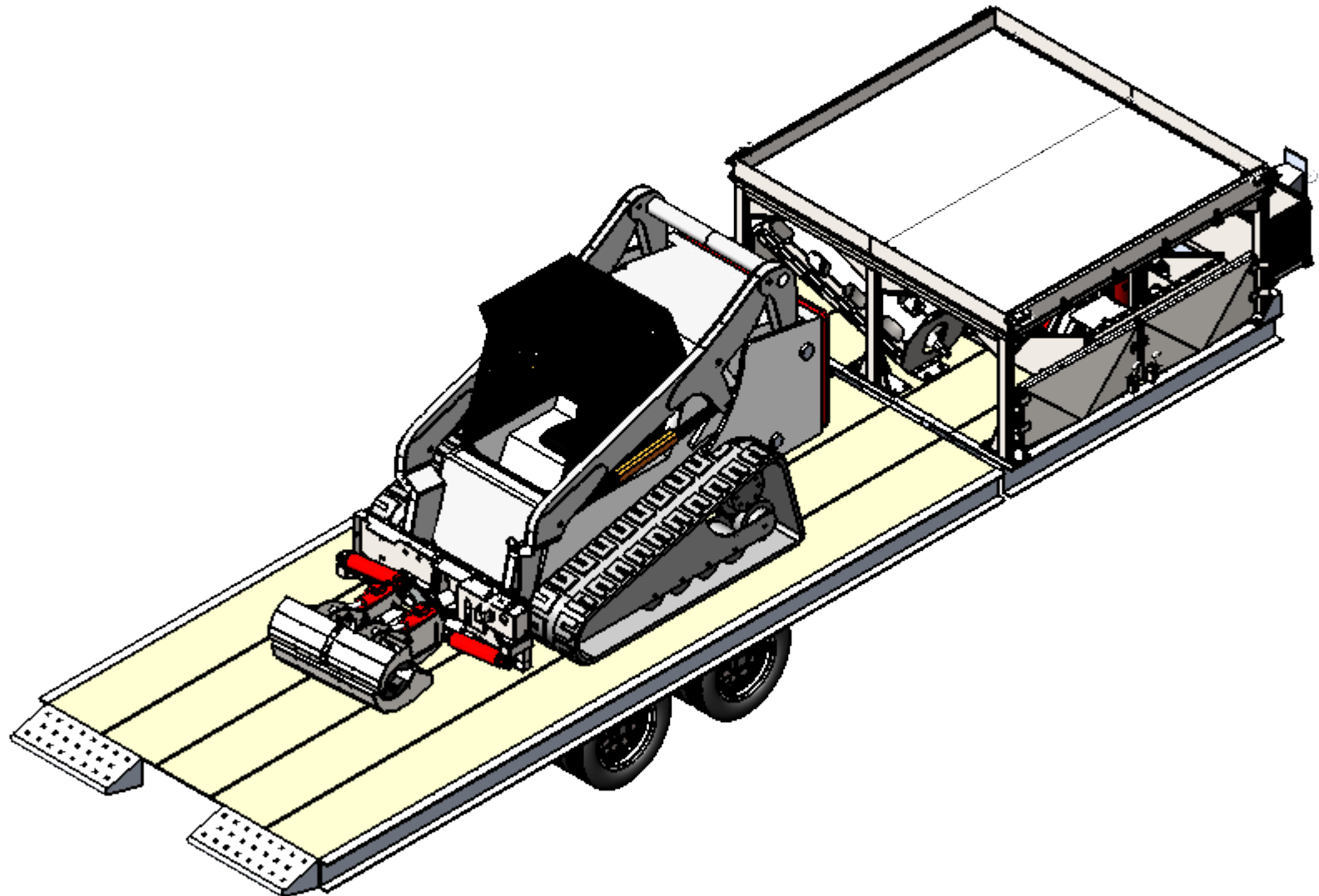
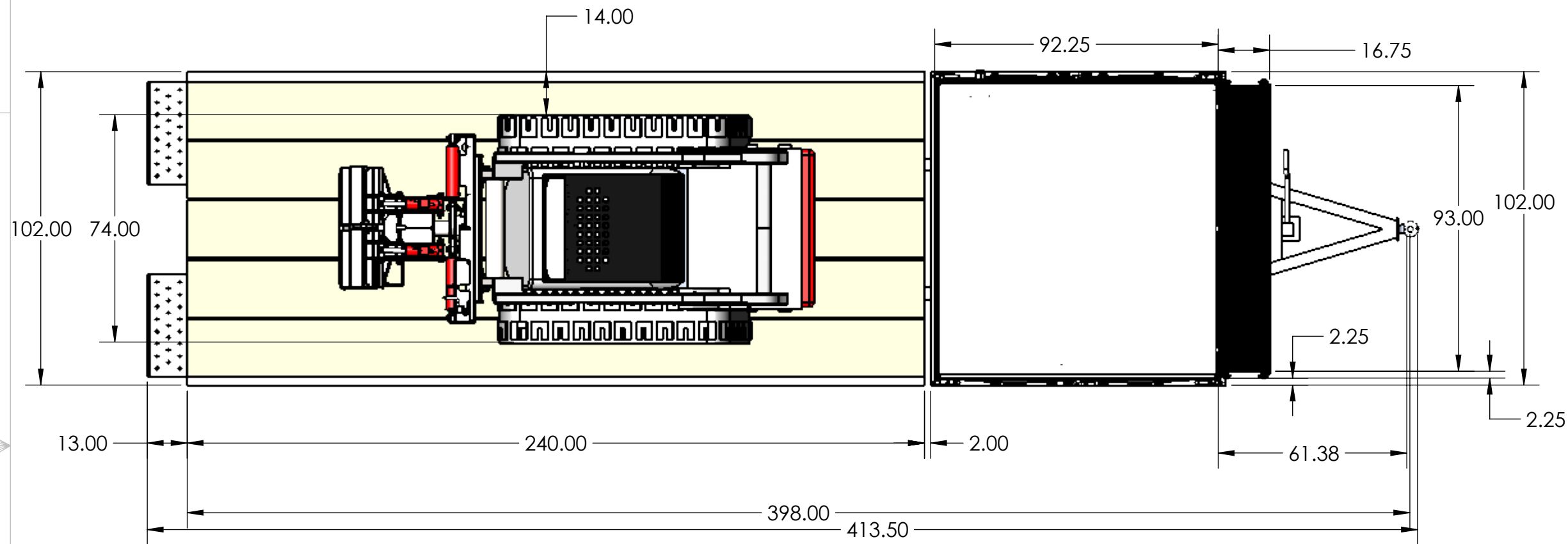
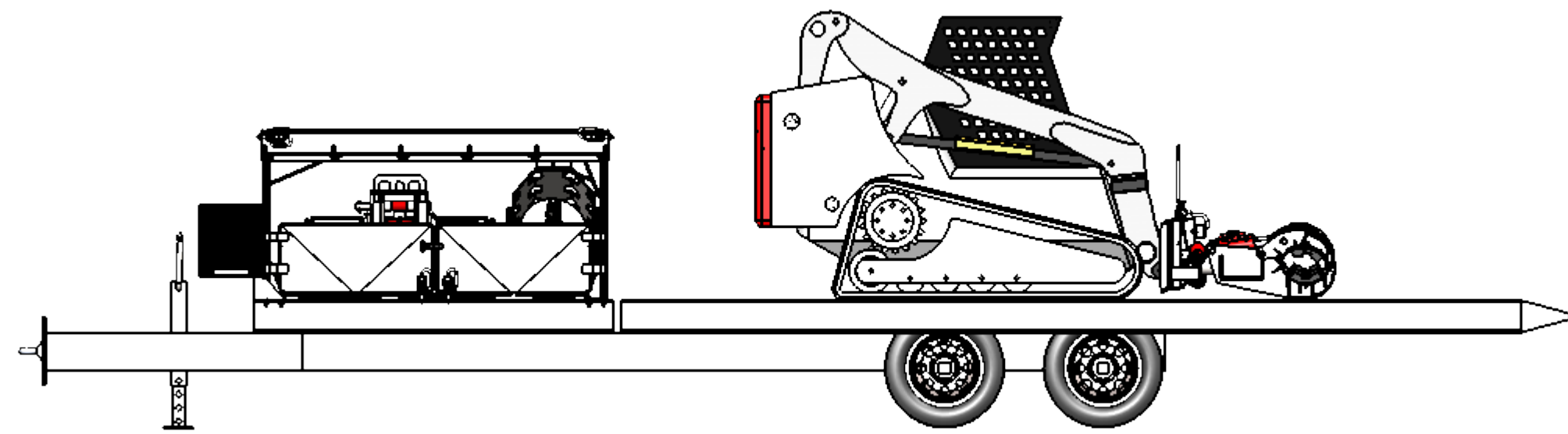

ITEM NO.	PART NUMBER	DESCRIPTION	QTY.
1	AGR-01-002	AUGER BASE WELDMENT	1
2	AGR-01-003	CONNECTOR FOR PLANETARY TO BASE	1
3	AGR-01-004	18" AUGER WELDMENT	1
4	AGR-01-008	PLANETARY WITHOUT BASE	1
5	Bobcat T750		1
6	MPJ-01-003	MINI POLE JACK ASSEMBLY	1
7	TR-01-023-B	FLAT BED TRAILER WITH RACK	1

PROPRIETARY AND CONFIDENTIAL
 THE INFORMATION CONTAINED IN THIS DRAWING IS THE SOLE PROPERTY OF EZ-SPOT-UR. ANY REPRODUCTION IN PART OR AS A WHOLE WITHOUT THE WRITTEN PERMISSION OF EZ-SPOT-UR IS PROHIBITED.

UNLESS OTHERWISE SPECIFIED:	NAME	DATE
DIMENSIONS ARE IN INCHES	DRAWN	BEVAN 8/8/2014
TOLERANCES:	CHECKED	
FRACTIONAL ±	ENG APPR.	
ANGULAR: MACH ± BEND ±	MFG APPR.	
TWO PLACE DECIMAL ±	Q.A.	
THREE PLACE DECIMAL ±	COMMENTS:	
INTERPRET GEOMETRIC TOLERANCING PER:		
MATERIAL		
FINISH		
DO NOT SCALE DRAWING		

EZ-SPOT-UR

TITLE:
FLAT BED TRAILER WITH RACKING AND EQUIPMENT

SIZE DWG. NO. REV
C TR-01-023 - RACKING ON FLATBED TRAILER WITH TOOLS **N**

SCALE: 1:40 WEIGHT: 30528.72 LBS SHEET 1 OF 1