



United States Department of Agriculture

# Structure Protection Materials Evaluation



Forest Service

National Technology & Development Program

5100 Fire Management

1251 1811—SDTDC October 2014

## **Structure Protection Abstract**

The USDA Forest Service and other federal land management agencies have administrative, and recreational buildings and other infrastructure located throughout the lands they manage. Some of these structures are historic buildings while others are used on a daily or seasonal basis. Many of these buildings are located in fire prone landscapes. The objective of this project was to evaluate the effectiveness of coatings, water enhancing gel and fabric wraps to protect structures from wildland and prescribed fire. Seventeen commercially available materials were selected for evaluation. These materials went through a three stage testing process to determine their fire resistance effectiveness. A water enhancing gel was also evaluated during the final phase of testing

---

## **Structure Protection Keywords**

Structure protection, passive protection systems, gel, wraps, coatings, foam, WUI, wildland fire, prescribed fire

---

### **Non-Discrimination Policy**

The U.S. Department of Agriculture (USDA) prohibits discrimination against its customers, employees, and applicants for employment on the bases of race, color, national origin, age, disability, sex, gender identity, religion, reprisal, and where applicable, political beliefs, marital status, familial or parental status, sexual orientation, or all or part of an individual's income is derived from any public assistance program, or protected genetic information in employment or in any program or activity conducted or funded by the Department. (Not all prohibited bases will apply to all programs and/or employment activities.)

### **To File an Employment Complaint**

If you wish to file an employment complaint, you must contact your agency's EEO Counselor (click the hyperlink for list of EEO Counselors) within 45 days of the date of the alleged discriminatory act, event, or in the case of a personnel action. Additional information can be found online at [http://www.ascr.usda.gov/complaint\\_filing\\_file.html](http://www.ascr.usda.gov/complaint_filing_file.html).

### **To File a Program Complaint**

If you wish to file a Civil Rights program complaint of discrimination, complete the USDA Program Discrimination form, found online at [http://www.ascr.usda.gov/complaint\\_filing\\_cust.html](http://www.ascr.usda.gov/complaint_filing_cust.html), or at any USDA office, or call (866) 632-9992 to request the form. You may also write a letter containing all of the information requested in the form. Send your completed complaint form or letter to us by mail at U.S. Department of Agriculture, Director, Office of Adjudication, 1400 Independence Avenue, S.W., Washington, D.C. 20250-9410, by fax (202) 690-7442 or email at [program.intake@usda.gov](mailto:program.intake@usda.gov).

### **Persons with Disabilities**

Individuals who are deaf, hard of hearing or have speech disabilities and you wish to file either an EEO or program complaint please contact USDA through the Federal Relay Service at (800) 877-8339 or (800) 845-6136 (in Spanish).

Persons with disabilities who wish to file a program complaint, please see information above on how to contact us by mail directly or by email. If you require alternative means of communication for program information (e.g., Braille, large print, audiotape, etc.) please contact USDA's TARGET Center at (202) 720-2600 (voice and TDD).

### **Forest Service Disclaimer**

The U.S. Department of Agriculture (USDA) prohibits discrimination in all its programs and activities on the basis of race, color, national origin, age, disability, and where applicable, sex, marital status, familial status, parental status, religion, sexual orientation, genetic information, political beliefs, reprisal, or because all or part of an individual's income is derived from any public assistance program. (Not all prohibited bases apply to all programs.) Persons with disabilities who require alternative means for communication of program information (Braille, large print, audiotape, etc.) should contact USDA's TARGET Center at (202) 720-2600 (voice and TDD). To file a complaint of discrimination, write USDA, Director, Office of Civil Rights, 1400 Independence Avenue, S.W., Washington, D.C. 20250-9410, or call (800) 795-3272 (voice) or (202) 720-6382 (TDD). USDA is an equal opportunity provider and employer.

# Structure Protection Materials Evaluation



by  
**George Broyles**—Fire Project Leader

San Dimas Technology and Development Center  
San Dimas, CA 91773



**KEY POINTS**

- Reducing the ignitability of a structure is the first and most important undertaking to prevent damage or loss of buildings in fire-prone landscapes.
- Wraps, coatings and gel were evaluated for their fire resistance and protective effectiveness.
- Performance of these materials is dependent on heat flux, duration of heat exposure, and environmental conditions.
- Wind and flame impingement are significant factors in the ability of these materials to adequately protect structures.
- Each type of material may have benefits for specific applications and conditions.
- Water-enhancing gel was shown to be effective in structure protection.

Materials with best performance characteristics

Material	Type
FX – WF	Coating
Firezat HD & LD	Wrap

**EXECUTIVE SUMMARY**

The Forest Service, an agency of the U.S. Department of Agriculture, and other Federal land management agencies have administrative and recreational buildings and other infrastructure located throughout the lands they manage. Some of these structures are historic buildings while others are used on a daily or seasonal basis; many of these buildings are located in fire-prone landscapes. The objective of this project was to evaluate the effectiveness of coatings, water-enhancing gel, and fabric wraps to protect structures from wildland and prescribed fire. Seventeen commercially available materials were selected for evaluation. These materials went through a three-stage testing process to determine their fire-resistance effectiveness. A water-enhancing gel also was evaluated during the final phase of testing.

Although these materials can provide various degrees of fire protection to structures, they should be considered as the last resort. Where buildings are located in fire-prone areas, the most effective fire-prevention strategy is to limit the ignition potential of the building and create and maintain defensive space around these structures (Foote et al. 1991, Koo et al. 2010, NFPA 1989). Adequate defensive space will provide structure protection at minimal cost, and more importantly, prevent the need for wildland firefighters to be placed in harm’s way when a fire approaches. Fire-resistant building designs and retrofits can greatly reduce the risk of structure loss during a wildland fire event. However, the violent and unpredictable nature of wildland fire can compromise even well-designed structures, thus emphasizing the need for “last-resort” structure-protection materials.

Absent defensible space, there are a number of passive-protection systems that may aid in protecting buildings and other infrastructure in the event of a wildland fire. This study evaluated different types of passive-protection systems: chemical (coatings and gel) and fabric-based (wraps). Each of these materials has unique advantages and disadvantages and like all wildland firefighting tools, each type may be more suitable for specific conditions. The materials were tested at the Charlotte, NC, Fire Department Academy under an agreement with the University of North Carolina, Charlotte (UNC Charlotte).

Based on this evaluation the highest-rated coating was FX-WF and the highest-rated wraps were Firezat LD/HD. ThermoGel 200L was the only water-enhancer evaluated.

### **INTRODUCTION**

The Forest Service's National Technology and Development Program's San Dimas Technology and Development Center (SDTDC) received several project proposals relating to structure protection. The Fire and Aviation Steering Committee combined these proposals into one project that was to be done in multiple phases. Together these project proposals requested research and testing of alternative materials including coatings, foams, and gels, methods of application, best practices for wrapping structures, and identifying new techniques for structure protection.

Phase 1 is being prepared by the National Technology and Development Program's Missoula Technology and Development Center. The publication from this phase will be available on the National Technology and Development Web site and will provide suggestions and ideas for protecting agency structures. It provides basic guidance on current structure-protection techniques for Forest Service employees.

Phase 2 is the evaluation of commercially available materials and coatings, which has been accomplished by this project.

### **PREVENTION**

Firefighter safety is the first and most important consideration in all wildland and prescribed fire planning. Although all wildland firefighters carry a fire shelter while working on wildland fires, the shelter is designed to be used only as a last resort. Firefighter safety presumes that the shelter will never be used; tactics and strategies are not developed with the intention that shelter deployment may be needed. Therefore, while planning for structure protection, managers also must consider firefighter safety first and foremost. The best way to provide for firefighter safety is to ensure—with as much certainty as possible—that any structure located where wildland or prescribed fire may present a hazard can withstand a fire without human intervention.

Ignition of a structure by wildland fire may be caused by radiant heat, convective heat, or from firebrands (burning pieces of wood) coming in contact with the structure or igniting nearby fuels. Research and case studies have shown that the primary cause of a structure burning is the structure's ignitability (Cohen 1990). Because wildland fires are inevitable on many Federal wildlands it becomes imperative to reduce the potential for structures to ignite. Effectively reducing the ignitability of agency structures will provide the greatest margin of safety for firefighters and limit the possibility of damage to property. In many cases this also will be the most cost-effective method of protection (Howard et al. 1973). Buildings located in national forests or grasslands can be considered as fuel so the most effective means of reducing ignition potential is to change the building's fuel profile. Wooden roofs are susceptible to ignition from firebrands, and can in turn create more firebrands (Foote et al. 1991).

In addition to firefighter safety, cost also must be considered. Retrofitting existing buildings can be costly if new fire-resistant materials are needed. However, structure protection ahead of an approaching fire is costly too. Howard et al. (1973) analysis found that there is a positive cost/benefit to owners who maintain defensive space and utilize nonflammable building materials. Materials, labor, and delivery will add to the cost of structure protection using passive-protective systems and may be required numerous times for the same structure.

## TESTING

Material testing was accomplished through a cooperative agreement with UNC Charlotte. Reports submitted by the university Structure Protection Project, contain the test procedures and results (Zhou 2010, Zhou 2011, Zhou 2012). UNC had previous experience (Urbas et al 2010, Urbas et al. 2011) testing the fire-protection properties of water enhancers. In addition, UNC has a fully equipped fire laboratory and outdoor test facility located on the Charlotte, NC, Fire Department training grounds. There were three phases in the test process representing three scales: the bench-scale (10 centimeter by 10 centimeter) (10 cm by 10 cm), the intermediate scale (100 cm by 100 cm), and full scale. Each phase was designed to test material performance and select the materials with the best fire-resistance properties to be tested in the next phase. The use of three different testing phases allowed for the evaluation of more materials while reducing the cost of the testing. This method also provided valuable information on each material that was selected for future testing. The initial test was done using 10 cm by 10 cm samples in a Cone Calorimeter per ASTM E1354.<sup>1</sup> Results from the Cone Calorimeter determined which materials would be tested in the second phase, the Intermediate-scale Calorimeter (ICAL) test per ASTM E1623.<sup>2</sup> The final phase of testing was done on large, outdoor structures on which

the test materials were applied and subjected to fire intensities that simulated actual wildland fire conditions.

Seven wraps were included in the Cone Calorimeter test and four were selected for further evaluation in the ICAL tests. Ten intumescent coatings<sup>3</sup> were tested in the Cone Calorimeter and three were selected for additional testing on the ICAL. Results from the ICAL test determined the final materials that would be tested in the full-scale outdoor test. Materials in the outdoor test included three wraps, Firezat LD, Firezat HD, and S-Barrier; and five coatings, Shingle Kote, Fire Kote 100, Flameseal FX-WF and FX-100, and NoFire A-18. After completion of the ICAL tests, SDTDC was tasked with testing a water-enhancing gel. Thermo Gel 200L was selected for evaluation in the large-scale outdoor test because it is on the Federal Qualified Products List.

---

<sup>1</sup> American Society of Testing and Materials (ASTM). (2010). *ASTM E 1354-10, Standard Test Method for Heat and Visible Smoke Release Rates for Materials and Products Using an Oxygen Consumption Calorimeter*, ASTM International, West Conshohocken, Pennsylvania.

<sup>2</sup> American Society of Testing and Materials (ASTM). (2009). *ASTM E 1623-09, Standard Test Method for Determination of Fire and Thermal Parameters of Materials, Products, and Systems Using an Intermediate Scale Calorimeter (ICAL)*, ASTM International, West Conshohocken, Pennsylvania.

<sup>3</sup> Intumescent coatings can be applied to walls and roofs prior to or after construction. These coatings do not affect the appearance of the substrate they are applied to. When they are exposed to high temperatures a chemical reaction occurs, which causes a charred layer to form over the substrate. The char layer acts as a thermal barrier and helps prevent heat transfer to the substrate.

## Structure Protection Materials Evaluation

Table 1—Materials evaluated\*

No.	Coatings	Wrapping
1	Fire-Kote 100 (Universal Fire Shield)	Firezat HD
2	Shingle Kote (Universal Fire Shield)	Firezat LD
3	FX-100 (Flameseal)	S-Barrier (NoFire)
4	FX-WF (Flameseal)	Textile 2025 (NoFire)
5	Latex (Ceasefire)	Textile 2035 (NoFire)
6	High Performance (Ceasefire)	Textile 7246 (NoFire)
7	Clear (Ceasefire)	Yogi Barrier
8	Waterborne Epoxy (Ceasefire)	
9	Superior (Ceasefire)	
10	A-18 (NoFire)	

\* Thermo Gel 200L was not part of the original study.

There are distinct differences between the three types of materials evaluated in this study. Wraps are solid materials (fabrics) that are attached physically to buildings; coatings are liquids that can be applied to the roof and walls of structures in the same manner as paint; and gels are sprayed onto the roof and walls of structures. Coatings have the advantage of being applied to a building prior to or after construction and are not dependent on the timing of wildland fire. These coatings become part of the structure and may be incorporated into the design or modification of existing buildings. Paint can be applied over these coatings so the structure can maintain its original appearance. Wraps must be applied to the structure using staples, bands, or nails (MTDC). Installing wraps requires sufficient materials, time, and resources so that the building can be adequately protected before the fire approaches and firefighting personnel can leave the area if necessary. The wrap also must be removed after the threat has passed. Installation and removal can cause damage to the building.

In many cases, wraps cannot be reused, so additional costs are incurred each time a building needs protection. Water enhancers such as gels<sup>4</sup> must be applied to a structure shortly before a fire approaches. Gels can be applied relatively quickly depending on the size of the structure and assuming there is an available pressurized water source. They become less effective over time as the gel/water dries out. The gel must be washed off the structure after the threat has passed or it will remain affixed to the surfaces it is applied to.

<sup>4</sup>Water enhancers (gels) improve the ability of water to cling to vertical and smooth surfaces by making water thick and sticky. The thick, sticky layer of water insulates fuels and delays ignition. The consistency of these products can change drastically depending on the quality of mix water. As with foams, these products also rely on the water they contain to suppress the fire. Once the water has evaporated, they are no longer effective, but generally last longer than foams. (Wildland fire chemicals)



### CONE CALORIMETER TESTS

This test was designed to determine the viability of each material that would be used in the ICAL test. The Cone Calorimeter (figure 1) provides results for each material's ignitability, heat release rate, mass loss rate, and ability to maintain structural integrity when exposed to radiant heat flux. Materials were initially tested at 25 kilowatts per square meter ( $\text{kW}/\text{m}^2$ ) and  $65 \text{ kW}/\text{m}^2$  because these values are representative of the heat associated with wildland fire situations. Since none of the wraps ignited at  $65 \text{ kW}/\text{m}^2$  additional tests were conducted at  $85 \text{ kW}/\text{m}^2$ . Each material was tested several times at each heat flux level to assure the results were valid. A total of 129 tests were performed on the Cone Calorimeter (Zhou 2010).



Figure 1—Cone calorimeter.

One of the primary determinants in a structure's ability to withstand a fire is whether or not the building will ignite from a firebrand (referred to as "piloted ignitions"<sup>5</sup>). Firebrands can cause structure ignition if they land on a roof or other area of a structure that is conducive to ignition or these firebrands can start a fire when they land on vegetation near a structure. The Cone

Calorimeter was used to test each material's ignitability by measuring the time-to-ignition (TTI). Time-to-ignition is the minimum time required for a material to ignite and sustain a fire. The Cone Calorimeter test included an electrical spark to simulate a piloted ignition. Firezat HD and LD and S-Barrier did not ignite when subjected to a heat flux of  $85 \text{ kW}/\text{m}^2$ . The materials were exposed for 2,000 seconds (33 minutes 20 seconds). For coatings, A 18, FX 100, and FX WF exhibited the longest TTIs at  $25 \text{ kW}/\text{m}^2$  and  $65 \text{ kW}/\text{m}^2$ .

Heat release rate (HRR) is the amount of heat a burning material will release and therefore provide to sustain burning of the substrate. The HRR can be used to determine a material's fire-reaction property. Heat release rate provides the best measure of fire reaction property for coatings. Results from the Cone Calorimeter tests indicated that FX 100, FX WF, and A-18 exhibited the best fire-reaction properties for coatings.

Based on the full results from the Cone Calorimeter tests the following materials were selected for further testing in the ICAL: coatings FX 100, FX WF, A-18, Shingle Kote, and Fire Kote 100. For the ICAL test researchers selected Firezat HD, Firezat LD, S-Barrier, and Textile 2025 wraps.

### INTERMEDIATE CALORIMETER TEST

Materials tested in the ICAL were attached or applied to a 100 cm by 100 cm oriented strand board (OSB) panel. The ICAL can subject materials to a constant radiant heat flux of up to  $50 \text{ kW}/\text{m}^2$ . A piloted ignition source also was present to simulate firebrand ignition. Materials were tested two times at three heat flux levels:  $25 \text{ kW}/\text{m}^2$ ,  $35 \text{ kW}/\text{m}^2$ , and  $45 \text{ kW}/\text{m}^2$ . A new OSB panel with fresh coating or new fabric wrap was

<sup>5</sup> *Piloted ignition*—When wood is sufficiently heated, it decomposes to release combustible volatiles. At a sufficient volatile—air mixture, a small flame, or hot spark can ignite it to produce flaming; thus, a piloted ignition.

used for each test. The ICAL measures the same fire resistance and effectiveness parameters as the Cone Calorimeter (figure 2). In addition, due to its larger sample size thermocouples can be mounted to the samples to measure temperature history at various locations. The measured temperatures can be used to determine time to reach 139 °Celsius (C)/181 °C ( $t_{\text{interface}}$ ) and thermal resistance (R) of a material. Time to reach 139 °C/181 °C is the lesser of the two times for the interface temperature at the surface of the OSB panel, to reach either the average value of 139 °C or a maximum of 181 °C. These values are used to determine the probability of ignition of the substrate material. Thermal resistance indicates the ability of a material to resist heat and provide thermal insulation. Time to reach ( $t_{\text{interface}}$ ) and thermal resistance indicate the ability of a material to insulate the substrate from radiant and convective heat and are useful in determining the protection effectiveness of wraps. Time to ignition is the best measure for evaluating the effectiveness of coatings. Initial measurements of untreated OSB were taken to determine the baseline for ignition times and increased interface temperatures.

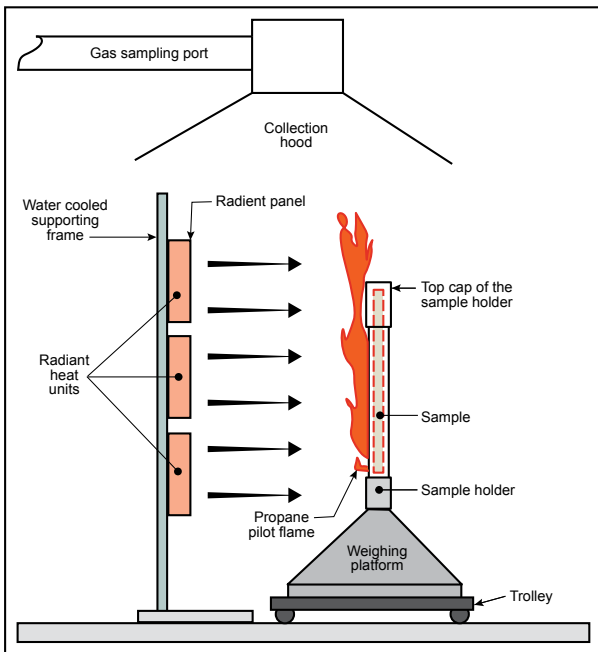

Figure 2—ICAL schematic.



Figure 3—ICAL test.

During the ICAL tests (figure 3), Textile 2025 was the only wrap that ignited. Time-to-reach values were greatest for Firezat HD, Firezat LD, and S-Barrier respectively. Thermal resistance for these three wraps was identical to the time-to-reach rankings. Results from the ICAL measurements for coatings indicated that TTIs were longest for FX-WF, A-18, and FX-100 respectively (figure 4).



Figure 4—FX-WF in ICAL.

Based on the ICAL results these three coatings, FX-WF, FX-100, and A-18 were selected for the full-scale outdoor test. Wraps selected for the full-scale outdoor tests were Firezat LD, Firezat HD, and S-Barrier.

### FULL-SCALE OUTDOOR TEST

The full-scale outdoor test was designed to validate the Cone Calorimeter and ICAL tests and to simulate fire conditions found during wildland and prescribed fires. These tests measured time-to-ignition, heat flux, and temperature and were conducted on three coatings and three wraps. Thermo Gel 200L also was evaluated in the outdoor test.

Wooden assemblies were constructed for the outdoor test. The structure walls consisted of 12-foot by 8-foot plywood and the roofs were 12-foot by 4-foot Western cedar (figures 9 and 10). Materials were attached or applied to the entire structure according to the manufacturers' recommendations. Each coating was tested at two heat flux levels: 35 kW/m<sup>2</sup> and 50 kW/m<sup>2</sup>. The wraps were tested at 50 kW/m<sup>2</sup> and the gel was tested at 50 kW/m<sup>2</sup> with drying times of 10 and 60 minutes. Heat was supplied by burning stacks of dried pallets and a piloted-ignition source was supplied by two ASTM E108 Type B firebrands, one placed on the wall and one attached to the roof assembly (figure 5 and figure 6). Heat-flux levels for the outdoor tests are not stable; ambient temperature, wind, pallet ignition, and fire growth all affect the amount of heat received by the test structures. However, in most cases the heat flux was at or near the designed level prior to ignition of the structures.



Figure 5—Firebrand on wall of outdoor test assembly.



Figure 6—Firebrand on roof of outdoor test assembly.

Results from the outdoor test differed from the results of the Cone and ICAL tests. These differences are attributed to the effects of wind, strong direct-flame impingement, and the resulting thermal impact on the materials' surfaces. The Cone and ICAL tests also did not have a convective heat component.

### Coatings

FX-WF outperformed the FX-100 and A-18 in the outdoor test. During the actual test FX-WF exhibited the greatest fire-resistance properties. FX-WF was subjected to much higher actual thermal attacks than the other two coatings as determined by the recorded surface temperatures, visual observation, and video recording.

### Wraps

Although none of the wraps ignited in the Cone and ICAL tests after 30 minutes, all of them ignited within 3 minutes during the outdoor tests. Firezat LD and Firezat HD ignited as the material delaminated from the peeling effect from close-surface aerodynamic forces caused by the combined effect of wind and strong direct-flame contact.

### Gel

Results from the gel tests revealed that Thermo Gel 200L provided a similar level of protection to the wraps and coatings in its ability to delay ignition. Test ignition first occurred on the roof at 2:31 (minutes:seconds) for the 10-minute drying time; roof ignition occurred at 1:58 for the 60-minute drying time test in the area where the firebrand was located (figure 7). Wall ignition occurred at 3:06 for the 10-minute drying time test and at 3:00 for the 60-minute drying time test. Temperature and heat-flux differences between these two tests may have contributed to the different ignition times. The heat flux on the wall during the 10-minute drying test was in the range of 30–40 kW/m<sup>2</sup> while the heat flux approached 60 kW/m<sup>2</sup> prior to ignition during the 60-minute test (figure 8).



Figure 7—Gel drying.



Figure 8—Gel test burn.

Table 2—Time-to-ignition (outdoor full-scale test)

Type	Test No.	Protection Materials	Design Heat Flux (kW/m <sup>2</sup> )	Weather Conditions		Time to Ignition (mm:ss)	
				Temp (F)	Max. Wind Speed (mph)	Wall	Roof (eave)
Coating	1	FX-100	35	82	1.3	2:12	2:24
	2		50	80	1.0	2:00	2:08
	3	A-18	35	86	4.0	2:29	1:37*
	4		50	85	3.0	1:35	1:17*
	5	FX-WF	35	75	4.5	2:04	1:28*
	6		50	86	5.0	1:43	1:41*
Wrap	7	Firezat LD	50	77	6.0	2:53	2:33*
	8	Firezat HD	50	80	4.5	2:29	2:15*
	9	S-Barrier	50	89	2.0	2:43	2:22*
Gel	10	Thermo Gel	50 (60min)	86	6.0	3:00	1:58
	11		50 (10min)	82	2.0	3:06	2:31

\* Ignition started at the eave

### Class A Foam

UNC Charlotte evaluated fire-resistance properties of water, Class A foam, and gel (Urbas et al. 2010; Urbas et al. 2011) using test procedures similar to those described in this publication with the exception that plants were located in front of the assemblies during the outdoor tests. Plants also were pretreated with water, foam, or gel. This testing revealed that gel outperformed both water and foam in resistance to ignition. Water and foam were not effective when exposed to extreme drying condition (60 minutes, 9 meters per second (m/s) wind, and 1 kW/m<sup>2</sup> radiant heat flux). Water and foam exhibited similar resistance properties with no drying time, as they did with 60-minute drying times. In the ICAL and outdoor full-scale tests gel had higher critical flux to ignition values than water and foam. After 10 minutes of drying time water and foam provided minimal protection. Ignition in most cases was initiated from the firebrand, which indicates that utilizing noncombustible roofing materials would significantly reduce the possibility of structure ignition. The results from this series of tests support the findings from the gel tests in our study.

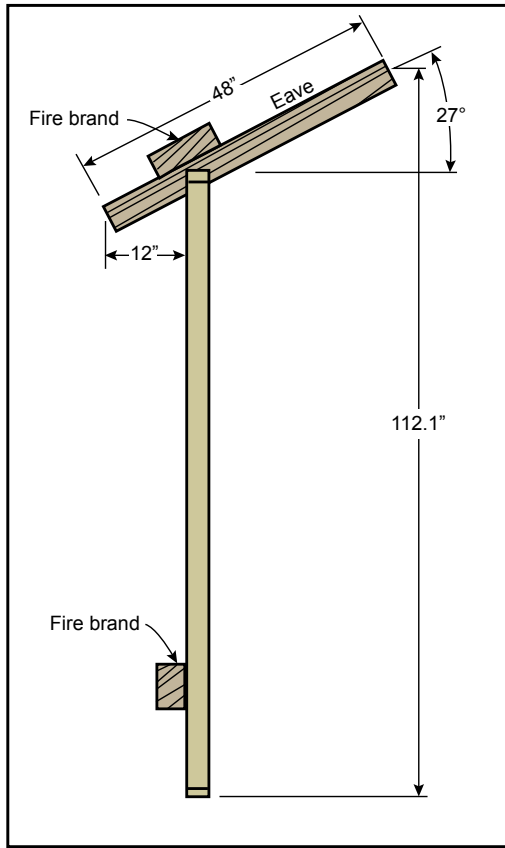

Figure 9—Outdoor test structure.



Figure 10—Outdoor test setup prior to ignition.

### SUMMARY AND CONCLUSIONS

Coatings and wraps were tested for fire-resistance properties under three discrete testing regimes: the Cone Calorimeter, ICAL, and large-scale outdoor tests. Gel was tested in the large-scale outdoor test. Parameters measured in these tests included time to ignition, mass loss, heat release rate, interface temperature, time to reach 139 °C/181 °C, and thermal resistance. Each test phase was designed to identify the materials with the best performance characteristics. The materials that performed best were selected for further testing in the next phase. The final large-scale outdoor test was designed to expose the selected materials to conditions that could be expected during a wildland fire. Tests results for the selected materials were consistent in the Cone Calorimeter and ICAL tests but showed marked differences in the full-scale outdoor tests. These differences can be attributed to the effects of wind, the resulting flame impingement, and the aerodynamic forces associated with wildland fire. When fire approaches a structure, each material can provide some level of protection. However, the effectiveness of any passive fire protection method will be compromised by the forces inherent in wildland fire.

Passive fire-protection materials may be suitable for certain situations but they can be much more effective if appropriate steps have been taken beforehand. Research and case studies indicate that the most effective way to minimize damage or loss of structures from wildland and prescribed fires is to reduce the ignitability of structures. “The congruence of research findings from different analytical methods suggests that home ignitability is the principal cause of home losses during wildland fires.” (Cohen 1999). Firebrands (piloted ignition) are a significant ignition source during wildland urban interface fires, particularly when flammable roofs are involved. Foote et al. (1991)

found a significant difference in home survival solely based on roof flammability. Homes with nonflammable roofs had a 70-percent survival rate compared with 19 percent for homes with flammable roofs. Their analysis of destroyed and damaged structures from the Paint Fire indicated that building construction and the immediate surroundings of the structure was significant in determining which buildings were capable of withstanding the fire.

Based on data from the Bel Air Fire of 1961 Howard et al. (1973) state that 100 feet of brush clearance and fire-resistant roofs could reduce the average annual loss of structures by a factor of 10. Although initial costs for roof conversion may be costly, the reduction in losses and insurance costs would exceed these prevention costs. Davis (1990) reported similar results related to roof flammability, and Cohen (1999, 2000) found that although firebrands may be lofted over considerable distances to ignite homes, a home's materials and design and its adjacent flammables largely determine the firebrand ignition potential. Buildings and other structures should have a minimum of 100 feet of clearance around them, and flammable materials should be removed. Buildings should be built or retrofitted with materials that will minimize the possibility of ignition from radiant and convective heat and firebrands. Cohen (2008) states "Research shows that a home's ignition potential during extreme wildfires is determined by the characteristics of its exterior materials and design and their response to burning objects within one hundred feet (thirty meters) and firebrands (burning embers)." Cohen (1999) goes on to say "An understanding of home ignitability provides a basis for reducing potential W-UI [wildland urban interface] fire losses in a more effective and efficient manner than current approaches."

Howard et al. (1973) conducted an economic analysis of the cost-versus-benefit of reducing structure ignitability and found "Our analysis indicates the most cost-effective way of reducing the Santa Monica fire problem is to improve brush clearance and roof resistance to fire."

Survival of a structure during a wildland fire is dependent on many factors including fire behavior, topography, and weather, which are beyond human control. However, other factors, such as clearance and building ignitability can be influenced by humans. Fire behavior and intensity, wind, direct-flame impingement, and so forth will all affect the survivability of a structure regardless of the prefire effort to protect it. Defensive actions taken during and immediately after the passage of a wildland fire may be effective at minimizing damage or loss but also may put firefighters in untenable situations. Foote (1994) assessed all buildings exposed to the Paint Fire and states that "mass transfer of burning embers and direct flame impingement were dominant mechanisms of structure ignition." His analysis found that the most significant determinant in predicting structure survival was roof type. The survival probability of buildings with nonflammable roofs was 47 percent versus 4 percent for buildings with wood shake/shingle roofs. Vegetation clearance improved structure survival from 4 percent to 21 percent.

Firefighter safety is the defining requirement for all fire-related activities. Therefore, agency managers should follow best practices and implement all measures possible to reduce the ignitability of buildings and other structures located in fire-prone landscapes. If buildings are still at risk of damage by wildland fire an appropriate passive-protective system should be selected.

## Structure Protection Materials Evaluation

Where possible, an intumescent coating (one that swells) should be used as these can be applied to buildings prior to the fire season and become incorporated into the building design. Wraps, although expensive can be applied early on and minimize firefighter exposure. However, wraps require the necessary resources (firefighters, transportation, and material availability). Gel is the most time-sensitive passive-protection system because its effectiveness degrades with time; firefighters must have the ability to apply it a short time before the fire reaches the area but still have time to safely leave the area.

### Coatings

The coating with the best performance was FX-WF (table 3). This product may delay the ignition of a structure, but as with all passive fire-protection systems, damage or loss is possible under severe or even moderate fire conditions. The effectiveness of a coating will ultimately be diminished by the heat, flames, or firebrands associated with a wildland fire. Application of the coating can be done safely without the concern of an approaching fire. This characteristic of coatings is advantageous over wraps and gels.

Table 3—Time-to-ignition (in seconds) for coatings—all test phases

Coatings	Cone Tests		ICAL Tests			Full-scale Tests	
	25kW/m <sup>2</sup>	65kW/m <sup>2</sup>	25kW/m <sup>2</sup>	35kW/m <sup>2</sup>	45kW/m <sup>2</sup>	35kW/m <sup>2</sup>	50kW/m <sup>2</sup>
FX-100	373	195	90	44	23	132 (wall)/ 144 (roof)	120 (wall)/ 128 (roof)
A-18	294	23	111	92	25	149 (wall)/ 97 (roof)	95 (wall)/ 77 (roof)
FX-WF	757	72	154	75	32	124 (wall)/ 88 (roof)	103 (wall)/ 101 (roof)

### Wraps

Firezat HD and LD performed best among the wraps. Although S-Barrier provided good resistance and thermal protection this wrap is too heavy and stiff to be used for structure protection. Tests indicated that when wrapping a structure, vertical seams perform better than horizontal seams. Wrapping structures often is time consuming and expensive. This is a critical factor that must be taken into account when considering wraps since the amount of time available to wrap a structure may be limited prior to a fire reaching the structure. Both the installation and the removal of wraps may cause damage to a structure, which may be especially important with historical buildings. If the structure has a wood roof it also will need to be wrapped, which may require special training and fall-protection equipment. As shown in the full-scale outdoor tests, wraps may delaminate and become ineffective under actual fire conditions due to wind and flame impingement (figure 11 and table 4).





Figure 11—Delamination of wrap.



Figure 12—Thermo Gel 200L.

Table 4—Results for wraps in outdoor full-scale test

	Wind Speed (mph)	TTI(s)	Ignition Location	Time to -Wrap Broken
Firezat LD	6	173 (wall)/153 (roof)	Broken area	130 (wall)/134 (roof)
Firezat HD	4.5	149 (wall)/135 (roof)	Broken area	230 (wall)/134 (roof)
S-Barrier	2	163 (wall)/ 142 (roof)	Overlap	>200

### Gel

Thermo Gel 200L exhibited fire-resistance properties comparable to the best-performing coating and wrap (figure 12). Although gels can be applied relatively quickly and easily, they require a water source and the appropriate equipment (pump/engine, and nozzle). Gels also have to be applied shortly before a fire approaches and this may place firefighters in danger if there is not adequate time to leave the area or if escape routes are compromised. As with wraps, gels must be cleaned off of structures after the threat from a fire has passed. This cleaning process requires a sufficient supply of water and must be done within a reasonable amount of time so that the gel does not dry and fully adhere to building surfaces.

The author acknowledges Aixi Zhou, Ph.D., University of North Carolina, Charlotte; Joe Fleming, mechanical engineering technician, San Dimas Technology and Development Center; and Captain Robert Myers, Charlotte Fire Department, for their contributions to this publication.

The author wishes to thank the following individuals for their technical review of this publication:

Aixi Zhou, Ph.D., Assistant professor, Fire Safety Engineering Technology, University of North Carolina, Charlotte

Sam Wu, P.E., mechanical engineer, San Dimas Technology and Development Center

Wes Throop, mechanical engineer, fire project leader, Missoula Technology and Development Center

Trevor Maynard, mechanical engineer, San Dimas Technology and Development Center

Ralph Gonzales, mechanical engineer, fire program leader, San Dimas Technology and Development Center

The National Technology and Development Center's national publications are available on the Internet at <<http://www.fs.fed.us/eng/pubs/>>.

Forest Service and U.S. Department of the Interior, Bureau of Land Management employees also can view videos, CDs, and National Technology and Development Center's individual project pages on their internal computer network at <<http://fsweb.sdtdc.wo.fs.fed.us/>>.

For additional information on the structure protection project, contact George Broyles, project leader, at 208-387-5638. Email: [gbroyles@fs.fed.us](mailto:gbroyles@fs.fed.us)

George Broyles is a Fire and Fuels project leader for the National Technology and Development Program at San Dimas Technology and Development Center in San Dimas, CA. He has worked in this position since November 2004. Prior to working at San Dimas he worked on the Black Hills National Forest. George's current duty station is the National Interagency Fire Center in Boise, ID.

**LITERATURE CITED**

- Cohen, J. 1999. Reducing the wildland fire threat to homes: where and how much? Gen. Tech. Rep. PSW-GTR-173. Albany, CA: U.S. Department of Agriculture, Forest Service, Pacific Southwest Research Station. 332 p.
- Cohen, J. 2000. Preventing disaster home ignitability in the wildland-urban interface. *Journal of Forestry*. 98(3): 15–21.
- Cohen, J. 2008. The wildland-urban interface fire problem a consequence of the fire exclusion paradigm. *Forest History Today*. 20–26.
- Davis, J. 1990. The wildland-urban interface: paradise or battleground. *Journal of Forestry*. 88(12): 26–31.
- Foote, E.I.D.; Martin, R.; Gilless, J.K. 1991. The Santa Barbara Paint Fire: data collection for urban-wildland interface structure loss analysis. Berkeley, CA: University of California, Berkeley, Fire Research Group. 14 p.
- Foote, E.I.D. 1997. Structure survival on the 1990 Santa Barbara “Paint” Fire: a retrospective study of urban-wildland interface fire hazard mitigation factors. Berkeley, CA: University of California.
- Howard, R.; North, D.; Offensend, R.; Smart, C. 1973. Decision analysis of fire protection strategy for the Santa Monica Mountains: an initial assessment. Menlo Park, CA: Stanford Research Institute.
- International Code Council. 2012. International wildland-urban interface code. Washington, DC: International Code Council. 47 p.
- Koo, E.; Pahn, P.; Weise, D.; Woychees, J. 2010. Firebrands and spotting ignition in large-scale fires. *International Journal of Wildland Fire*. Vol. 19: 818–843.
- Missoula Technology and Development Center. [In preparation] Structure protection. Missoula, MT: U.S. Department of Agriculture, Forest Service, Missoula Technology and Development Center.
- National Fire Protection Association. 1989. Black Tiger Fire case study. Quincy, MA: National Fire Protection Association.
- Urbas, J.; Desai, P. 2010. Effectiveness of pre-applied wetting agents in prevention of wildland urban interface fires. [pages unknown].
- Urbas, J.; Desai, P.; Kimble, J.; Murphy, D. Zhou, A.; Myers, R. 2011. Effectiveness of pre-applied wetting agents in prevention of wildland urban interface fires—full scale tests. [pages unknown].
- Wildland Fire Chemicals Tactics and Product Characteristics Ground Application. 2009. Missoula, MT: U.S. Department of Agriculture, Forest Service, Missoula Technology and Development Center, Wildland Fire Chemicals <<http://www.fs.fed.us/rm/fire/wfcs/training/index.htm>>.
- Zhou, A. 2010. Structure protection project: evaluation of coatings and wrapping systems for structural fire protection on national forest lands and the wildland urban interface, phase I: material selection through cone calorimeter fire tests. Charlotte, NC: University of North Carolina, William States Lee College of Engineering, Engineering Technology and Construction Management.

Zhou, A. 2011. Structure protection project: evaluation of coatings and wrapping systems for structural fire protection on the Federal forest lands and wildland urban interface, phase II report, intermediate-scale calorimeter (ICAL) fire tests. Charlotte, NC: University of North Carolina, William States Lee College of Engineering, Engineering Technology and Construction Management.

Zhou, A. 2012. Structure protection project: evaluation of coatings and wrapping systems for structural fire protection on national forest lands and the wildland urban interface final report full-scale outdoor fire tests. Charlotte, NC: University of North Carolina, William States Lee College of Engineering, Engineering Technology and Construction Management.

**APPENDIX**

Supplier Information

**NoFire Technologies**

(A-18, S-Barrier)  
21 Industrial Avenue  
Upper Saddle River, NJ 07458

**Firezat, Inc.**

5173 Waring Road  
Ste 158  
San Diego, CA 92120

**Thermo Technologies,**

LLC (ThermoGel)  
923 East Interstate Avenue  
Bismarck, ND 58503

**Flame Seal Products, Inc**

FX 100, FX – WF  
4025 Willowbend Road 310  
Houston, TX 77025

**UniShield International, LLC**

(Fire Kote -100, Shingle Kote)  
3544 Waterfield Parkway  
Lakeland, FL 33803

**New Line Safety, LLC**

(CeaseFire) Latex,  
High Performance Clear,  
Waterborne Epoxy, Superior  
34 Yorktown Road  
East Brunswick, NJ 08816