

Franklin

Madison

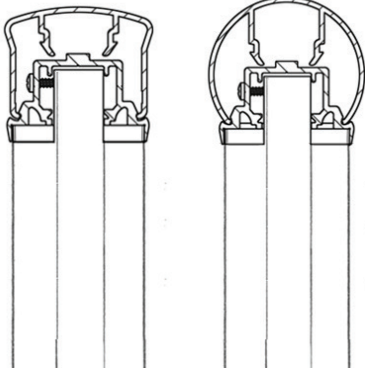

Finish:

Our advanced Powercoat™ finish allows us to produce a high quality, long-lasting finish, which is also environmentally friendly. The Powercoat™ finish is twice the thickness and hardness of a typical baked enamel finish. Meets AAMA 2604-5 standards for the ultimate in durability and UV protection.

Materials:

All Ultra Signature™ Collection railing components are extruded from Ultrum™ 6005-TS alloy, with a minimum ultimate strength of 35,000 psi. Every railing system is assembled with hidden stainless steel, corrosion-resistant fasteners. Ultra Signature™ Collection posts come in a variety of thicknesses. Designer Accessories are zinc die cast aluminum. All Designer Accessories are Powercoat™ finished.

Ultra Aluminum Lifetime Warranty

Ultra Aluminum™ fence and railing products are guaranteed for life against defects in workmanship and/or materials. The Powercoat™ finish on all fencing and railing by Ultra Aluminum™ is guaranteed for life against cracking, peeling or chipping. Visit our website for more information and a copy of the warranty.

Environmentally Responsible

Ultra Aluminum™ is proud to use recycled aluminum in our products. Aluminum is the most commonly recycled metal in the world. Our Powercoat™ coating process is environmentally friendly and virtually pollution-free.

Design Options

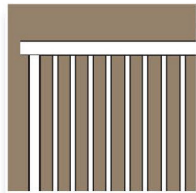

UARC-200-2R Two Rail

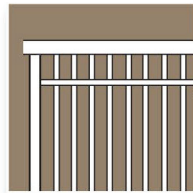

UARC-200-3R Three Rail

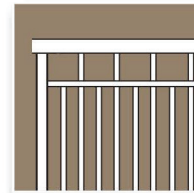

UARC-220-3R Three Rail

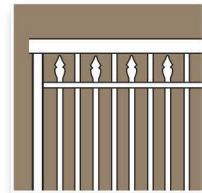

UARC-250-3R Three Rail with Spears

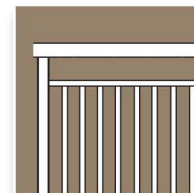

UARC-270-3R Three Rail

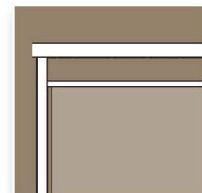

UAGC-270 3R Glass Railing

Railing Specifications

Components	Continuous
Square Picket	¾" sq. x .055" thickness
Top Cap Franklin	1.700"h x 2.250"w 0.080 thickness
Top Cap Madison	2.050"h x 2.500"w 0.080 thickness
Bottom Rail	1.375"H x 1.375"W 0.070 thickness
Boss Screw Posts	2" sq. x 0.125" 3" sq. x 0.125"
Spacing Between Pickets	3 ⅝"
Post Spacing	4' and 6' (Max)
Heights Available	36" & 42"
Signature Columns and Newel Posts	6" sq. 0.100" thickness
	8" sq. 0.100" thickness

Colors

Ultra Signature™ Collection railing, gates and designer accessories are available in nine classic colors as well as custom-specified hues. All colors are applied with a special Powercoat™ finish to resist harsh weather and heat.

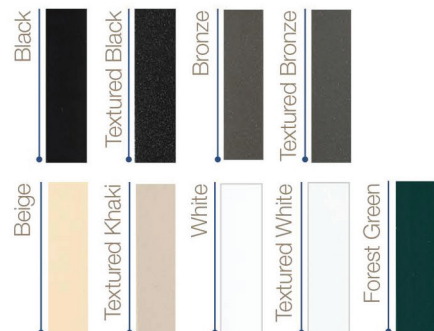

Colors shown represent an approximate comparison and may vary slightly from actual product color.

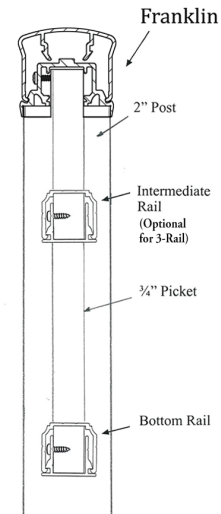
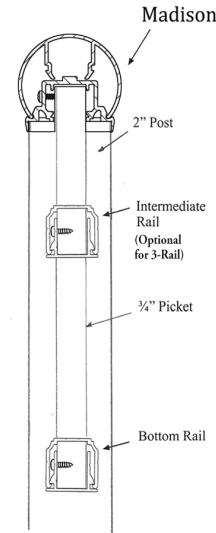
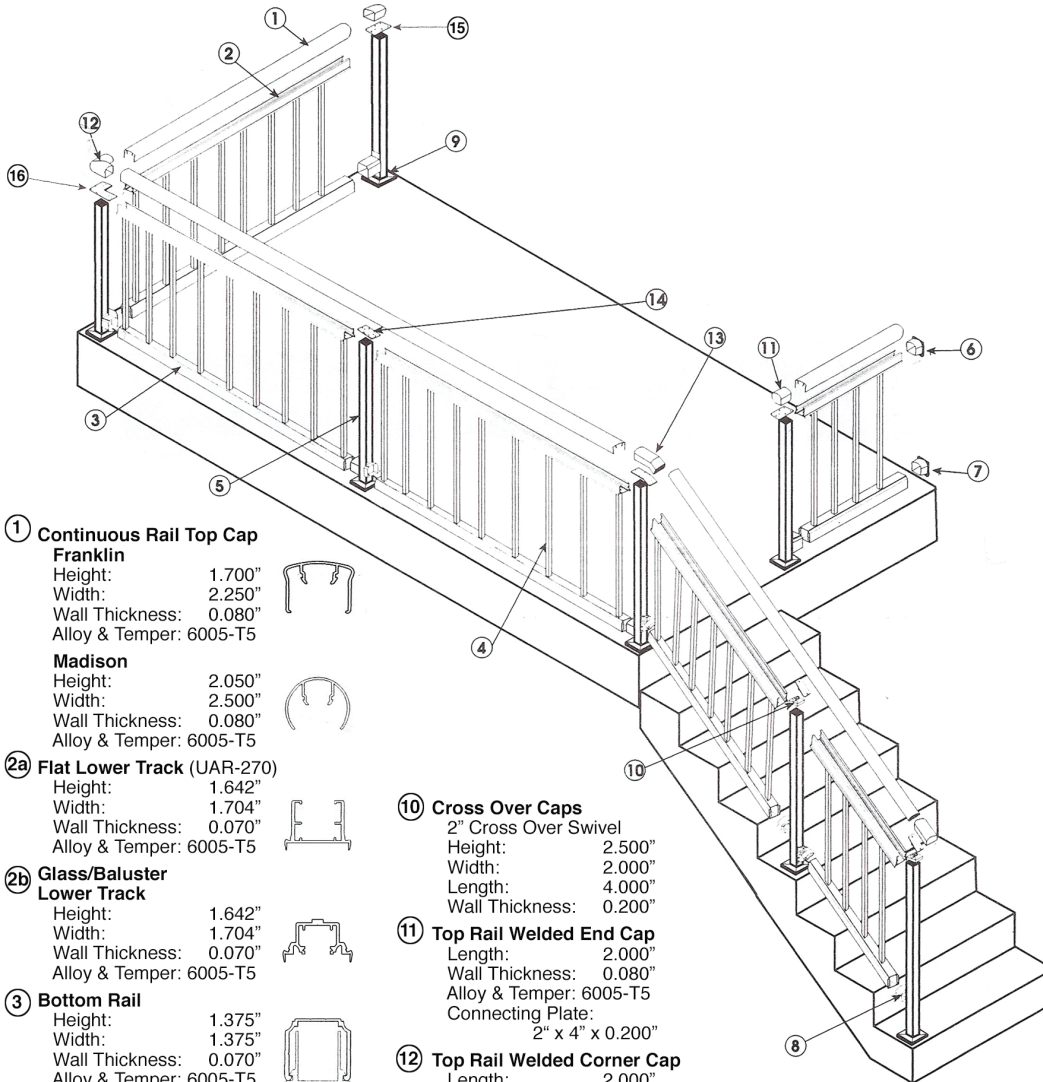

1 Continuous Rail Top Cap

Franklin
 Height: 1.700"
 Width: 2.250"
 Wall Thickness: 0.080"
 Alloy & Temper: 6005-T5



Madison
 Height: 2.050"
 Width: 2.500"
 Wall Thickness: 0.080"
 Alloy & Temper: 6005-T5



2a Flat Lower Track (UAR-270)

Height: 1.642"
 Width: 1.704"
 Wall Thickness: 0.070"
 Alloy & Temper: 6005-T5



2b Glass/Baluster Lower Track

Height: 1.642"
 Width: 1.704"
 Wall Thickness: 0.070"
 Alloy & Temper: 6005-T5



3 Bottom Rail

Height: 1.375"
 Width: 1.375"
 Wall Thickness: 0.070"
 Alloy & Temper: 6005-T5



4 3/4" x 3/4" Square Baluster

Wall Thickness: 0.055"
 Alloy & Temper: 6005-T5

5 Blank Post

2" Sq. x 2" Sq.
 Wall Thickness: 0.125"
 Alloy & Temper: 6005-T5
 3" Sq. x 3" Sq.
 Wall Thickness: 0.125"
 Alloy & Temper: 6005-T5

6 Standard Rail End Top Rail

Wall Thickness: 0.100"
 Alloy & Temper: A-360

7 Standard Rail End Bottom Rail

Wall Thickness: 0.100"
 Alloy & Temper: A-360

8 Adjustable Rail End Bottom Rail

Wall Thickness: 0.200"
 Alloy & Temper: A-360

9 Flange w/Skirt Cover

Thickness: 0.375"
 OD for 2" Cover: 4.375"
 OD for 2.5" Cover: 5.375"
 OD for 3" Cover: 5.375"
 Alloy & Temper: 6005-T5

10 Cross Over Caps

2" Cross Over Swivel
 Height: 2.500"
 Width: 2.000"
 Length: 4.000"
 Wall Thickness: 0.200"

11 Top Rail Welded End Cap

Length: 2.000"
 Wall Thickness: 0.080"
 Alloy & Temper: 6005-T5
 Connecting Plate:
 2" x 4" x 0.200"

12 Top Rail Welded Corner Cap

Length: 2.000"
 Wall Thickness: 0.080"
 Alloy & Temper: 6005-T5
 Connecting Plate:
 2" x 4" x 0.200"

13 Top Rail Welded Angle Cap and Stair Connector (Custom)

Length: 4.000"
 Wall Thickness: 0.080"
 Alloy & Temper: 6005-T5
 Connecting Plate:
 2" x 6" x 0.200"

14 Top Rail Straight Line Connector

Width: 2.000"
 Length: 4.000"
 Thickness: 0.200"
 Alloy & Temper: 6005-T5

15 Top Rail End Connector

Width: 2.000"
 Length: 4.000"
 Thickness: 0.200"
 Alloy & Temper: 6005-T5

16 Top Rail Corner Connector

Width: 4.000"
 Length: 4.000"
 Thickness: 0.200"
 Alloy & Temper: 6005-T5

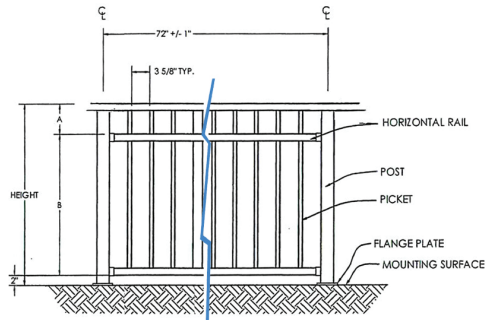

Dimensions			
Height	A	B	Panel Hgt.
36"	6"	28"	34"
42"	6"	34"	40"