

# Garrote

---

## OPERATION AND MAINTENANCE OF SOUND SUPPRESSOR MODEL

### Garrote

**Before using this suppressor,  
be certain you have read and  
understand this manual.**

Manufactured by

**Subgun Ordnance  
Racine WI 53406**

★ ★ ★ ★ ★ **WARNING** ★ ★ ★ ★ ★

☞ **Because sound suppressed weapons make less noise than non-suppressed weapons, it is easy to forget that they are still firearms. It is of vital importance to remember that a sound suppressed firearm is just as dangerous as a non-suppressed one, and the same safe handling requirements apply.**

**COPYRIGHT NOTICE:**

©2010 Subgun Ordnance

All rights reserved. The contents of this publication may not be reproduced in any form or by any means in whole or in part without the prior written permission of the copyright owner.

# **GARROTE**

OPERATIONAL MANUAL FOR  
SOUND SUPPRESSOR MODEL  
Garrote (.22 LR)

*Manufactured by*

**Subgun Ordnance**  
RACINE WI 53406

web: [www.subgun-ordnance.com](http://www.subgun-ordnance.com)  
email: [subgun-ordnance@sbcglobal.net](mailto:subgun-ordnance@sbcglobal.net)  
Phone: 262-770-9894  
FAX: 262-635-8305

## **GARROTE user instructions**

### **CONTENTS:**

General Description .....	P. 2
Ammunition Recommendation .....	P. 2
Installation .....	P. 3
Maintenance and cleaning .....	P. 4
Disassembly .....	P. 4
Reassembly .....	P. 6
Physical Specifications .....	P. 7
Threading Specifications .....	P. 7

☆☆☆☆☆ **WARNING** ☆☆☆☆☆

☞ **Failure to follow installation and maintenance instructions detailed in this manual can result in potential for serious injury to the user and damage to the weapon.** Firearm sound suppressors are user attached firearm muzzle devices, and as such are subject to improper attachment unless the proper procedures outlined in this manual are followed.

**MANUFACTURER'S DISCLAIMER**

The manufacturer is not responsible for improper usage of this product. This product is potentially dangerous, and as such it is the user's responsibility to understand and implement its proper use. If you do not understand the instructions in this manual, please contact the manufacturer for further clarification.

## GENERAL DESCRIPTION

The Garrote™ is the answer to those who wanted a relatively small, fully user-serviceable suppressor for the the popular (but dirty) .22LR cartridge. No packing material or wipes are used in these units. Designed to meet requirements for an affordable, compact, highly efficient muzzle suppressor, this unit is radically different from conventional silencer designs. it demonstrates out-standing dry sonic performance.

The Garrote features a titanium thread insert to prevent thread wear occasionally possible with aluminum threads. Titanium does not gall on properly threaded steel barrels.

The Garrote™ is easily disassembled without the need for specialized tools.

## AMMUNITION RECOMMENDATIONS

Because this is a muzzle suppressor, there is no velocity control of the projectile. On rifles, HV ammunition will be accompanied by the "ballistic crack" of the bullet in flight. For maximum suppression effect, we suggest the use of standard velocity target type .22 rimfire ammunition such as CCI Green Tag, CCI standard velocity ammunition or Remington Subsonic. Hyper velocity cartridges such as the CCI Stinger® and Remington Yellow Jacket® will cause a significant increase in sound signature. These cartridges should be avoided if possible. This suppressor is designed only for .22LR caliber rimfire ammunition. It has not been tested with .22 Magnum nor with .17

HMR. While these cartridges may or may not be suitable, their use is not covered under warranty. **It must not be used with any type of centerfire ammunition.**

**The Aguilla SSS 60 gr. subsonic ammunition does not always stabilize in barrel twists readily available and can yaw badly on exit from the rifling. This will seriously damage the internal components of your suppressor, and use of this ammunition is at the user's risk.**

☆☆☆☆☆ **WARNING** ☆☆☆☆☆

☞ Failure to follow installation instructions detailed in this manual can result in potential for serious injury to the user and damage to the weapon.

## INSTALLATION

Before installing (or removing) the suppressor on the weapon, be certain to remove the magazine, open the action, and visually ascertain that the weapon is unloaded.

The suppressor mounts on conventional 1/2x28 (Class 2A) threads. Maximum thread length on the barrel is 4/10 inch. For proper alignment, the muzzle threads must be absolutely concentric with the bore and must have a 90° rear shoulder perpendicular to the bore. We cannot guarantee alignment on improperly threaded barrels. Threading specifications are on P. 7.

Screw on finger tight only. **DO NOT overtighten.** There is no need to “monkey grip” it in place.

☆☆☆☆☆ **DANGER** ☆☆☆☆☆

☞ Before performing any maintenance operation, always remove the magazine from the firearm, open the action, and visually ascertain that the chamber is empty and the weapon unloaded. Failure to do so can result in potential for serious injury to the user and others in the vicinity

## MAINTENANCE and CLEANING

As a general rule (and contrary to popular opinion), suppressors have a longer life if no attempt is made at cleaning. There are no perfect solvents for the carbon deposited on the internal parts by the burning of the powder, and some carbon residues will slightly enhance performance.

Because the .22 rimfire cartridge generates significant powder residue and condensation in the suppressor of vaporized lead (from the friction of the bare lead bullet in the rifling), the suppressor has been designed for easy disassembly and cleaning. Disassembly and cleaning should be performed after each day's shooting or at intervals not to exceed 250 rounds. Excessive intervals between disassembly and cleaning may make disassembly impossible outside the factory.

The suppressor is all aluminum, and many normal gun cleaning solvents will damage aluminum. These include Hoppe's, Sweets, GI Bore Cleaner, and all water-based agents (such as SLIP-2000, MP-7, Simple Green, etc.). Water and water-based solvents should never be used.

### DISASSEMBLY:

There are two drawings. One is a totally disassembled Garrote showing each individual part (figure 1). The other is a section drawing showing the Garrote completely assembled (figure 2).

The rear mount does not disassemble from the outer tube and is secured with Loctite. The reason it is non-removable is to maintain proper alignment of the suppressor body with respect to the muzzle threads. Do not attempt to remove.

Refer to figure 1 on the next page.

1. Unscrew the front end cap. The only tool needed is a coin, preferably a US 5-cent nickel.
2. With a dowel of approximately 3/8 inch diameter, push out the entire baffle stack from the rear. If using a wood dowel, it is acceptable to gently tap the dowel.
3. You will notice that the integrated spacer telescopes over and engulfs the previous baffle. This makes removal from the outer tube significantly easier without damaging the outer tube, which is the one part that cannot be replaced without creating a new suppressor.
4. Separate the baffles from each other. This may be difficult if cleaning is not done on a rigid schedule. Soaking in a solvent such as WD-40 may be of help.

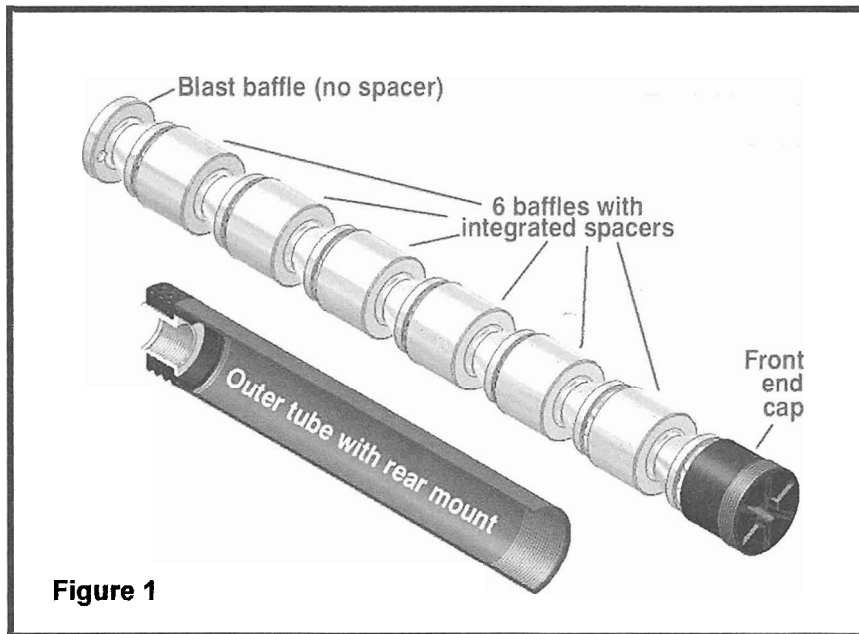

\*\*\*\*\* CAUTION \*\*\*\*\*

- ☞ Always read the warning label on any cleaner or solvent, and remember that virtually all solvents are inherently dangerous and potentially toxic. Always use adequate ventilation and both skin and eye protection when using organic solvents.
- ☞ Further, in the cleaning process, you are exposing yourself to elemental lead and lead salts, all toxic. Use adequate ventilation and wear rubber gloves when handling internal components of the suppressor.
- ☞ Used solvents are classified as hazardous waste and must be disposed of in accordance with applicable environmental requirements.

5. Clean all baffles as desired with solvent such as WD-40. Steel wool (#0000) or grey Scotchbrite may be used if a toothbrush is not adequate. Absolute cleanliness is not necessary, and damage from using a sand/bead blaster is not covered under warranty.

## REASSEMBLY:

Re-assembly is the reverse of disassembly. All thread surfaces should be coated with a very thin coating of either grease or a colloidal copper anti-seize compound. The sequence of assembly is important and must be followed as enumerated. Do not use excessive force tightening any threaded parts.

Refer to the drawing (figure 2) below.

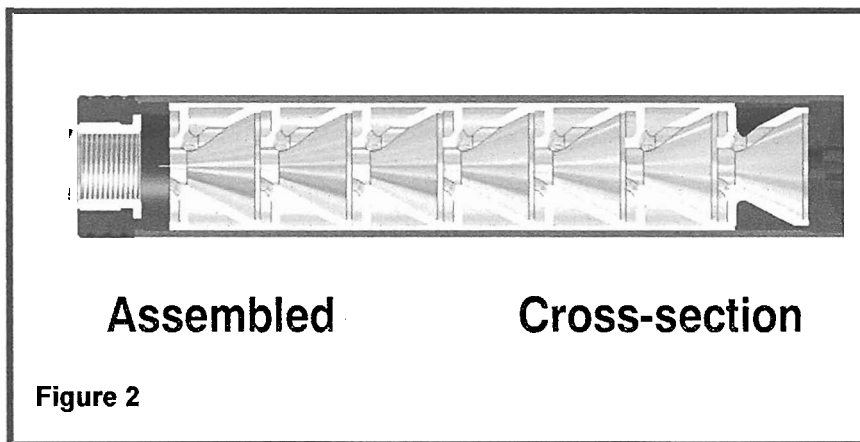

1. Figure 2 above shows the sequence of parts. All baffles (except the short blast baffle with the hole in the flat plate) are the same, and the order is not important. Notice that the front end cap telescopes over the baffle portion of the baffle below it.
2. Although the baffles can be dropped in place, it is far easier and faster to stack the baffles on a 1/4 inch rod with the spacer portion of the baffle being up. The blast baffle then inserts unto the spacer of the following baffle with the flat portion of the baffle up.
3. The orientation of the jets on the baffles is not really critical, and we have found no significant or measurable difference with differences in orientation.
4. Slip the outer tube over the baffle stack and seat.
5. Insert the cup-shaped front end cap and tighten finger tight with a coin.



**PHYSICAL SPECIFICATIONS**

Caliber	22 S, L, LR
Length	5.6 in.
Diameter	1 in.
Weight	3.7 oz.
Muzzle threads	1/2x28 (Class 2A)
Maximum Thread Length	4/10 inch (see P. 5)
Degree of Suppression (dry)	38 dB
Test Ammunition	CCI Green Tag

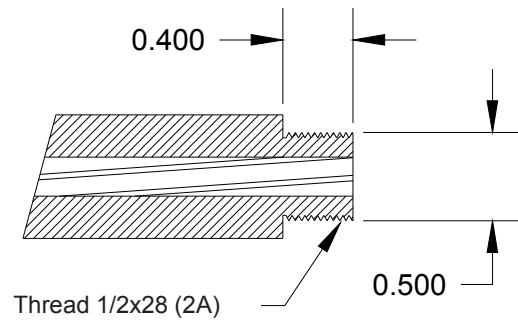
**Barrel Threading Specifications****Figure 3**