

susin i-tork

Heavy-Duty Pneumatic Actuator IS & IC Series



INNOBIZ CE
기술혁신형중소기업

Heavy-Duty Pneumatic Actuator IS & IC Series

- *The IS & IC series of heavy duty scotch yoke actuators are designed suitable for general purpose of valves and damper automation and offer a wide range of torques enable to operate ball, butterfly, plug valves, dampers or any device that requires a quarter-turn operation for on-off or modulating service.*
- *IS series is the symmetrical design yoke that produces maximum torque at both ends of the 90° cycle providing travel stops.*
- *IC series is the canted design yoke that max produces torque at either close or open end.*
- *Both series actuators come along with a complete line of controls and monitoring accessories including Manual Handwheel (jackscrew), hydraulic overrides, limit switches, solenoid valves, positioners and other controls accessories.*
- *Its modular design and construction provides maximized convenience during installation, maintenance and storage.*

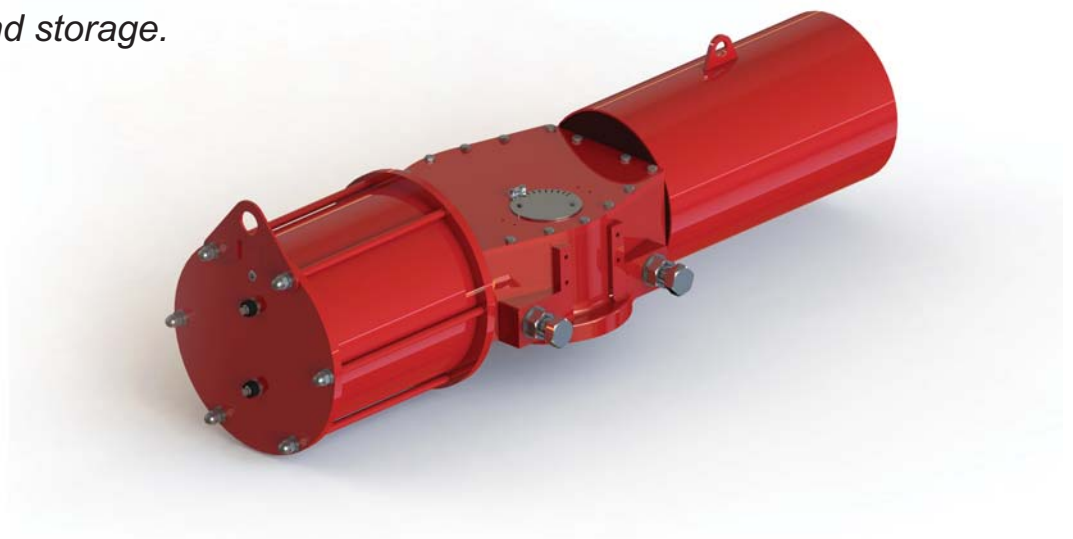

Standard IS & IC series actuator are provided with below features.

- Two years standard warranty.
- IP66 for water ingress protection and corrosion resistance.
- Interchangeable modular construction - an advantage for inventory, service, maintenance
- Standard operating pressure: 40 to 100 PSIG (2.8 to 7 Bar)
- Standard operating temperature: -20°C to +80°C with high and low temperature optional trims available.
- Mounting dimension is to meet with ISO5211

Optional

- Different temperature range : -30°C to 100°C
- Different pressure range: Max. 10 Bar
- Manual operation : Hydraulic or Handwheel (jackscrew), Declutchable gear box
- Different mounting dimension: (MSS-SP101 or others on request)

MODULAR CONSTRUCTION

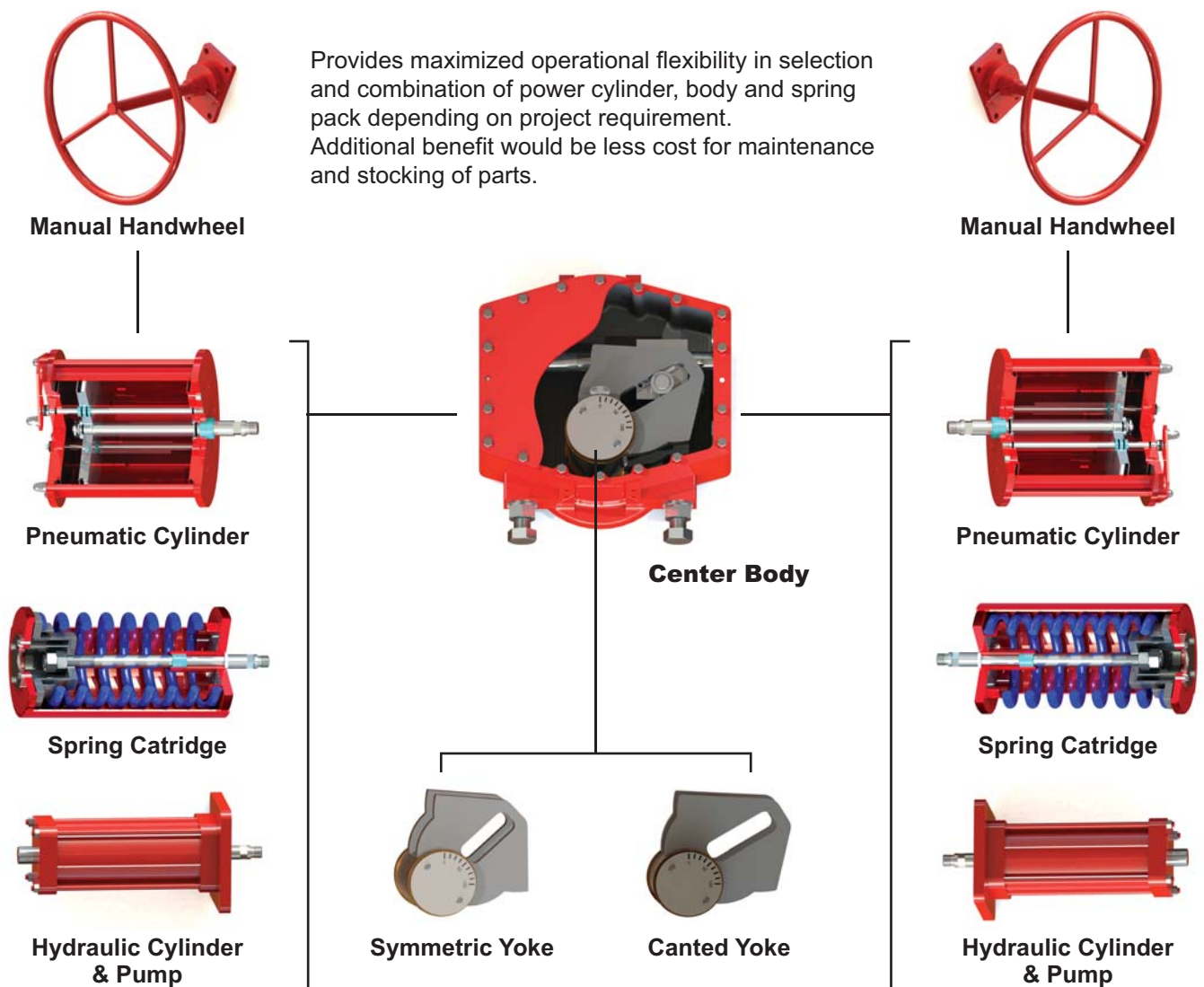

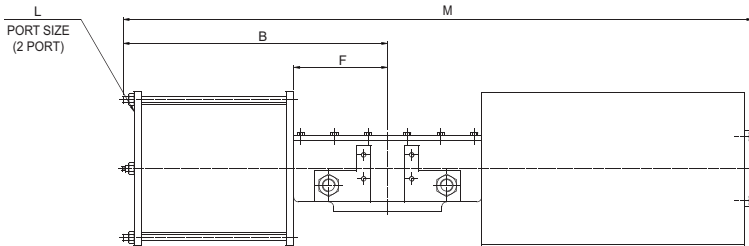
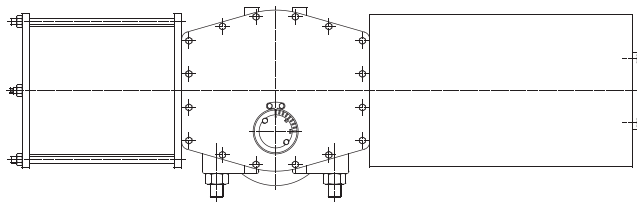

< SPRING RETURN >



H	I		J		K	L	M	
	PCD	TAP/DP	DIA	DP			4.2 Bar	5.5 Bar
54	165	M20/25	50	156	14	1/2" NPT	1280	1280
54	165	M20/25	50	156	14	1/2" NPT	1280	1280
54	165	M20/25	50	156	14	1/2" NPT	1280	1280
54	165	M20/25	50	156	14	1/2" NPT	1280	1280
80/85	254	M16/27	75/80	204	20	1/2" NPT	1475	1475
80/85	254	M16/27	75/80	204	20	1/2" NPT	1475	1475
80/85	254	M16/27	75/80	204	20	1/2" NPT	1475	1475
95.4/105.4	298	M20/34	90/100	234	22	3/4" NPT	1860	1860
95.4/105.4	298	M20/34	90/100	234	22	3/4" NPT	1860	1860
95.4/105.4	298	M20/34	90/100	234	22	3/4" NPT	1860	1860
117.4/127.4/137.4	356	M30/43	110/120/130	279	32	3/4" NPT	2240	2240
117.4/127.4/137.4	356	M30/43	110/120/130	279	32	3/4" NPT	2240	2240
117.4/127.4/137.4	356	M30/43	110/120/130	279	32	3/4" NPT	2240	2240
137.4/147.4/157.4	406	M36/53	130/140/150	326	32	3/4" NPT	2695	2695
137.4/147.4/157.4	406	M36/53	130/140/150	326	32	3/4" NPT	2695	2695
137.4/147.4/157.4	406	M36/53	130/140/150	326	32	3/4" NPT	2695	2695

H	I		J		K	L	M	
	PCD	TAP/DP	DIA	DP			4.2 Bar	5.5 Bar
54	165	M20/25	50	156	14	1/2" NPT	1325	1325
54	165	M20/25	50	156	14	1/2" NPT	1325	1325
54	165	M20/25	50	156	14	1/2" NPT	1325	1325
54	165	M20/25	50	156	14	1/2" NPT	1325	1325
80/85	254	M16/27	75/80	204	20	1/2" NPT	1510	1510
80/85	254	M16/27	75/80	204	20	1/2" NPT	1510	1510
80/85	254	M16/27	75/80	204	20	1/2" NPT	1510	1510
95.4/105.4	298	M20/34	90/100	234	22	3/4" NPT	1935	1935
95.4/105.4	298	M20/34	90/100	234	22	3/4" NPT	1935	1935
95.4/105.4	298	M20/34	90/100	234	22	3/4" NPT	1935	1935
117.4/127.4/137.4	356	M30/43	110/120/130	279	32	3/4" NPT	2320	2320
117.4/127.4/137.4	356	M30/43	110/120/130	279	32	3/4" NPT	2320	2320
117.4/127.4/137.4	356	M30/43	110/120/130	279	32	3/4" NPT	2320	2320
137.4/147.4/157.4	406	M36/53	130/140/150	326	32	3/4" NPT	2750	2750
137.4/147.4/157.4	406	M36/53	130/140/150	326	32	3/4" NPT	2750	2750
137.4/147.4/157.4	406	M36/53	130/140/150	326	32	3/4" NPT	2750	2750

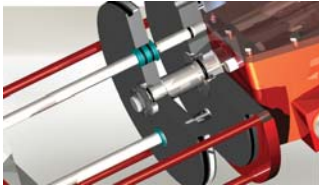

Guide Bar for Safety Increased

Provided two piston guide (Up & down) bars preventing piston's droop due to abrasion after a long time of use, and engineering Plastic Bush for the pistons with good durability of abrasion and lubricative characteristic enable to keep smooth operation at low pressure as well.

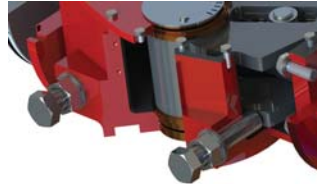

Piston Guide Ring

High quality Back-up Ring preventing any possible leakage and ensure long lifespan.



Travel Stop / Adjustment And Indicator

Travel stop/adjustment can be set in the range of -5° ~ $+95^{\circ}$ of stroke and the stoppers are designed in vertical touch in order to bear big shock.

Indicator with pointer & angle meter for easy and convenient use



Standard NAMUR Mounting Dimension

For easy installation of accessories like limit switch box, positioners & etc.

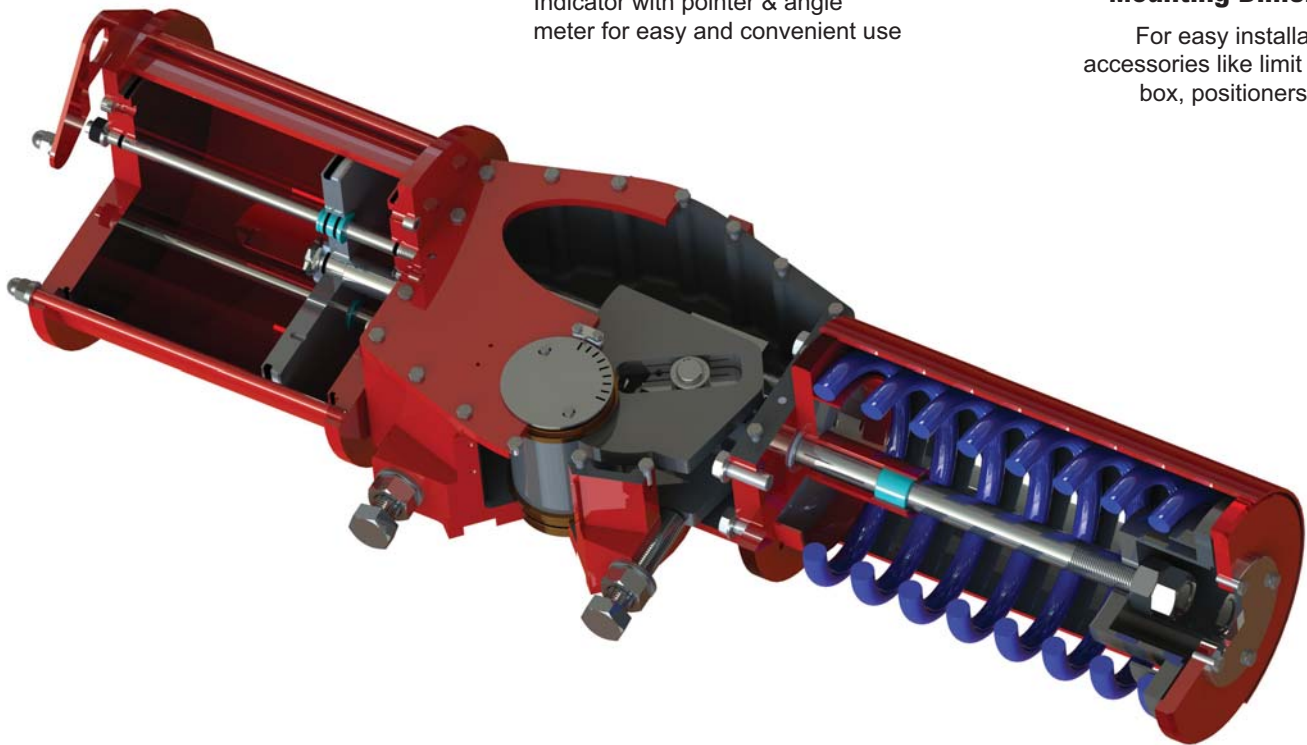

Replaceable Bearing

Surface heat-treated Slide Pin, Slide Bearing, and Yoke Slide provides semi-permanent lifespan with strong durability of abrasion.



Spring Rod Guide

Hard anodized Aluminum casting and external epoxy powder coated against severe industrial environment.



Adaption

In order for direct mounting valve and actuator without separate coupler and bracket, bore diameter for valve shaft is increased, so that it can accept thicker diameter shaft rather than standard. Mounting flange as per ISO5211

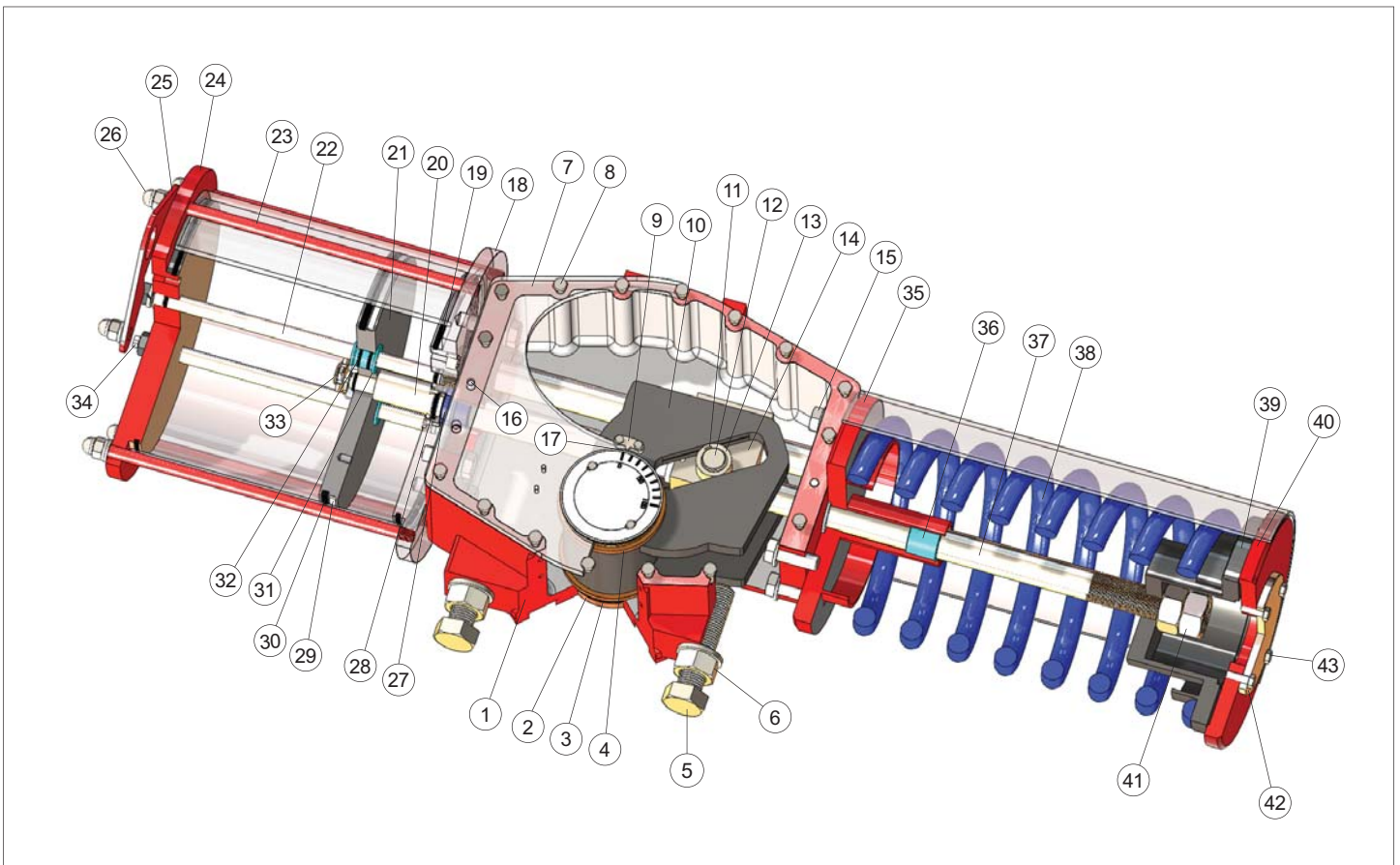

NO	DESCRIPTION	MATERIAL
1	BODY	DUCTILE IRON
2	LOWER BUSHING	BSC
3	O-RING	NBR
4	UPPER BUSHING	BSC
5	STOPPER BOLT	ALLOY STEEL
6	STOPPER NUT	ALLOY STEEL
7	CENTER BODY COVER	ALLOY STEEL
8	CENTER BODY COVER BOLT	ALLOY STEEL
9	POINTER	STS
10	YOKE	ALLOY STEEL
11	SNAP RING	ALLOY STEEL
12	SLIDE PIN	ALLOY STEEL
13	SLIDE ROLLER	ALLOY STEEL
14	SLIDE BLOCK	ALLOY STEEL
15	FRONT COVER BOLT	ALLOY STEEL
16	COVER FIXING PIN	ALLOY STEEL
17	POSITION INDICATOR	ALLOY STEEL
18	CYLINDER FRONT COVER	ALLOY STEEL
19	COVER O-RING	NBR
20	PISTON ROD	ALLOY STEEL
21	PISTON	ALLOY STEEL
22	PISTION GUIDE BAR	ALLOY STEEL

NO	DESCRIPTION	MATERIAL
23	TIE BOLT	ALLOY STEEL
24	CYLINDER END COVER	ALLOY STEEL
25	LIFTING LUG	ALLOY STEEL
26	TIE BOLT NUT	ALLOY STEEL
27	FRONT COVER BUSHING	ENGINEERING PLASTIC
28	O-RING	NBR
29	BACK-UP RING	PTFE
30	PISTON O-RING	NBR
31	PISTON GUIDE BUSHING	ENGINEERING PLASTIC
32	PISTON GUIDE BUSHING O-RING	NBR
33	PISTON LOCK BOLT	ALLOY STEEL
34	PISTON GUIDE BAR NUT	ALLOY STEEL
35	SPRING CASE FRONT COVER	ALLOY STEEL
36	SPRING ROD GUIDE BUSHING	ENGINEERING PLASTIC
37	SPRING ROD	ALLOY STEEL
38	SPRING	ALLOY STEEL
39	SPRING RETAINER	ALLOY STEEL
40	SPRING CASE END COVER	ALLOY STEEL
41	SPRING ROD LOCK NUT	ALLOY STEEL
42	COVER	ALLOY STEEL
43	COVER BOLT	ALLOY STEEL

SYMMETRIC TECHNICAL DATA

Double Acting Actuator

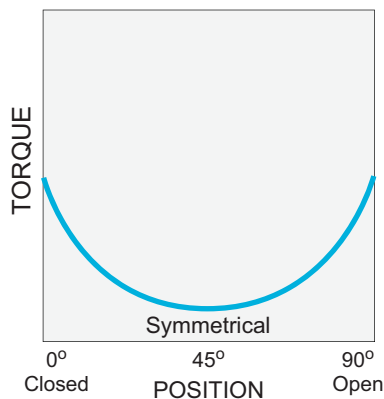

Spring Return Actuator

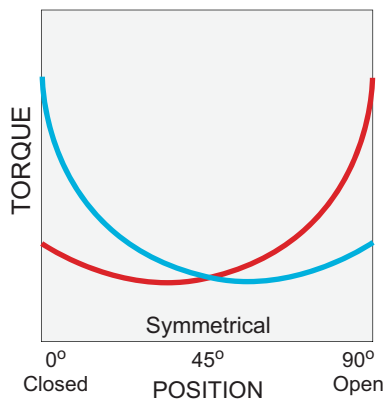

Symmetric Yoke



Torque Curve — Air Torque — Spring Torque

Double Acting

Unit : Nm

MODEL	2.8 Bar			4.2 Bar			5.5 Bar			7 Bar		
	Start	Run	End	Start	Run	End	Start	Run	End	Start	Run	End
ISD 02-20	993	616	973	1,491	923	1,460	1,988	1,232	1,947	2,484	1,539	2,433
ISD 02-25	1,553	962	1,521	2,329	1,443	2,281	3,105	1,924	3,041	3,882	2,406	3,801
ISD 02-30	2,236	1,385	2,189	3,353	2,078	3,284	4,472	2,771	4,380	5,589	3,464	5,485
ISD 02-35	2,788	1,728	2,731	4,182	2,591	4,095	5,576	3,455	5,461	6,970	4,318	6,826
ISD 03-35	3,280	2,032	3,213	4,920	3,049	4,819	6,560	4,064	6,424	8,200	5,081	8,031
ISD 03-38	4,332	2,684	4,143	6,498	4,026	6,364	8,664	5,369	8,486	10,830	6,710	10,607
ISD 03-43	5,530	3,427	5,416	8,295	5,140	8,125	11,061	6,854	10,833	13,826	8,567	13,541
ISD 04-43	7,190	4,455	7,041	10,784	6,682	10,562	14,379	8,909	14,082	17,974	11,138	17,604
ISD 04-48	8,938	5,538	8,753	13,406	8,307	13,130	17,874	11,075	17,507	22,343	13,845	21,882
ISD 04-53	10,875	6,739	10,651	16,312	10,107	15,976	21,750	13,477	21,301	27,187	16,846	26,627
ISD 05-53	13,385	8,294	13,109	20,077	12,440	19,663	26,769	16,587	26,217	33,462	20,734	32,771
ISD 05-58	16,003	9,916	15,673	24,006	14,871	23,510	32,007	19,833	31,347	40,009	24,790	39,183
ISD 05-63	18,856	11,684	18,467	28,284	17,526	27,700	37,712	23,367	36,935	47,140	29,210	46,168
ISD 06-63	23,570	14,604	23,084	35,355	21,907	34,626	47,140	29,210	46,168	58,925	36,512	57,710
ISD 06-68	27,428	16,995	26,862	41,142	25,493	40,294	54,855	33,991	53,724	59,569	42,488	67,156
ISD 06-73	31,578	19,567	30,927	47,367	29,350	46,390	63,156	39,134	61,854	78,945	48,917	77,318

SYMMETRIC TECHNICAL DATA

Spring Return (Fail closed or Fail open)

Unit : Nm

MODEL		Spring Torque			Air Torque : Air Supply Pressure											
					2.8 Bar			4.2 Bar			5.5 Bar			7 Bar		
		Start	Run	End	Start	Run	End	Start	Run	End	Start	Run	End	Start	Run	End
ISR 02-20	4.2 Bar	982	499	609	415	135	21	928	453	523	1,440	770	1,024			
	5.5 Bar	1,271	644	781				756	308	234	1,268	625	736	1,780	943	1,237
ISR 02-25	4.2 Bar	1,489	757	924	677	235	78	1,477	731	862	2,278	1,226	1,646			
	5.5 Bar	1,993	1,010	1,225				1,176	478	358	1,976	974	1,142	2,777	1,470	1,926
ISR 02-30	4.2 Bar	2,141	1,503	1,301	1,004	348	116	2,156	1,062	1,245	3,309	1,776	2,374			
	5.5 Bar	2,947	1,469	1,841				1,617	640	440	2,769	1,354	1,568	3,922	2,068	2,697
ISR 02-35	4.2 Bar	2,679	1,352	1,628	1,246	429	136	2,683	1,320	1,544	4,120	2,210	2,951			
	5.5 Bar	3,466	1,759	2,140				2,171	912	756	3,608	1,802	2,164	5,046	2,693	3,571
ISR 03-35	4.2 Bar	3,136	1,587	1,921	1,460	508	176	3,151	1,556	1,832	4,842	2,603	3,488			
	5.5 Bar	4,189	2,120	2,566				2,506	1,023	779	4,197	2,070	2,435	5,887	3,118	4,091
ISR 03-38	4.2 Bar	4,007	2,023	2,438	2,028	744	367	4,261	2,128	2,554	6,494	3,512	4,741			
	5.5 Bar	5,391	2,729	3,303				3,397	1,422	1,170	5,630	2,806	3,357	7,863	4,190	5,544
ISR 03-43	4.2 Bar	4,957	2,506	3,028	2,673	1,027	627	5,524	2,793	3,419	8,374	4,559	6,211			
	5.5 Bar	7,223	3,554	4,097				4,455	1,745	1,153	7,306	3,511	3,945	10,156	5,287	6,737
ISR 04-43	4.2 Bar	7,142	3,531	4,106	3,306	1,062	118	7,012	3,358	3,747	10,718	5,654	7,377			
	5.5 Bar	9,352	4,635	5,411				5,707	2,254	1,536	9,413	4,550	5,166	13,119	6,847	8,796
ISR 04-48	4.2 Bar	8,854	4,378	5,090	4,124	1,331	170	8,731	4,186	4,681	13,337	7,040	9,193			
	5.5 Bar	11,372	5,582	6,406				7,414	2,982	2,164	12,021	5,836	6,675	16,628	8,691	11,187
ISR 04-53	4.2 Bar	10,745	5,323	6,214	4,997	1,624	240	10,603	5,098	5,730	16,208	8,571	11,220			
	5.5 Bar	14,234	7,054	8,236				8,581	3,366	2,236	14,187	6,840	7,726	19,793	10,313	13,217
ISR 05-53	4.2 Bar	13,231	6,585	7,745	6,053	1,965	284	12,953	6,240	7,041	19,852	10,515	13,798			
	5.5 Bar	17,431	8,675	10,204				10,494	4,150	2,841	17,393	8,425	9,598	24,293	12,700	16,355
ISR 05-58	4.2 Bar	15,538	7,733	9,296	7,403	2,490	621	15,652	7,601	8,700	23,901	12,713	16,779			
	5.5 Bar	20,710	10,308	12,124				12,624	5,027	3,527	20,873	10,138	11,606	29,122	15,250	19,685
ISR 05-63	4.2 Bar	18,742	9,328	10,971	8,468	2,717	297	18,187	8,740	9,816	27,907	14,762	19,335			
	5.5 Bar	24,132	12,010	14,127				15,032	6,057	4,426	24,752	12,080	13,945	34,471	18,102	23,464
ISR 06-63	4.2 Bar	23,515	11,608	13,456	10,842	3,449	283	22,992	10,977	12,821	35,131	18,505	24,080			
	5.5 Bar	29,704	14,640	16,924				19,524	7,945	5,992	31,673	15,473	17,891	48,823	23,001	29,790
ISR 06-68	4.2 Bar	26,637	13,149	15,243	13,034	4,372	1,056	27,172	13,133	14,903	41,310	21,893	28,749			
	5.5 Bar	35,779	17,662	20,474				21,940	8,620	5,761	36,078	17,380	19,607	50,216	26,141	33,454
ISR 06-73	4.2 Bar	31,134	15,368	17,816	14,739	4,804	750	31,016	14,890	16,692	47,293	24,974	32,633			
	5.5 Bar	40,471	19,978	23,159				25,673	10,280	7,354	41,950	20,366	23,296	58,228	30,452	39,238

CANTED TECHNICAL DATA

Double Acting Actuator

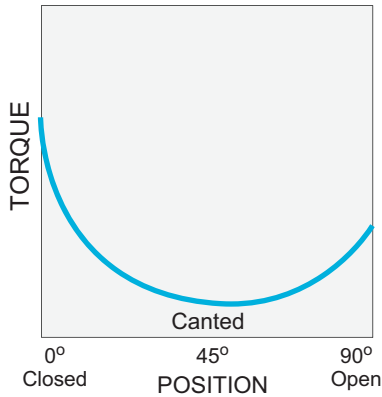

Spring Return Actuator

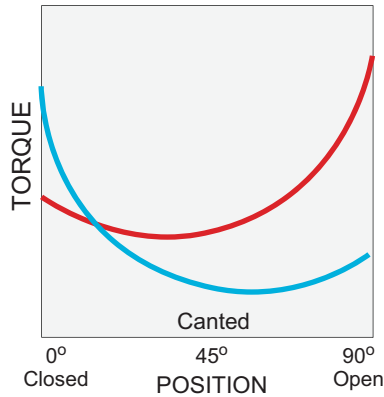

Canted Yoke



Torque Curve — Air Torque — Spring Torque

Double Acting

Unit : Nm

MODEL	2.8 Bar			4.2 Bar			5.5 Bar			7 Bar		
	Start	Run	End	Start	Run	End	Start	Run	End	Start	Run	End
ICD 02-20	1,245	616	868	1,868	923	1,302	2,491	1,232	1,736	3,114	1,539	2,170
ICD 02-25	1,946	962	1,356	2,919	1,443	2,035	3,893	1,924	2,713	4,866	2,406	3,391
ICD 02-30	2,802	1,385	1,954	4,204	2,078	2,929	5,605	2,771	3,906	7,006	3,464	4,883
ICD 02-35	3,494	1,728	2,436	5,242	2,591	3,653	6,989	3,455	4,871	8,736	4,318	6,089
ICD 03-35	4,111	2,032	2,865	6,166	3,049	4,298	8,222	4,064	5,731	10,277	5,081	7,163
ICD 03-38	5,430	2,684	2,785	8,145	4,026	5,676	10,859	5,369	7,569	13,574	6,710	9,461
ICD 03-43	6,932	3,427	4,832	10,397	5,140	7,247	13,863	6,854	9,662	17,329	8,567	12,078
ICD 04-43	9,011	4,455	6,281	13,517	6,682	9,421	18,023	8,909	12,562	22,528	11,138	15,701
ICD 04-48	11,202	5,538	7,808	16,802	8,307	11,711	22,404	11,075	15,615	28,005	13,845	19,518
ICD 04-53	13,630	6,739	9,500	20,446	10,107	14,250	27,261	13,477	19,000	34,076	16,846	23,750
ICD 05-53	16,776	8,294	11,692	25,164	12,440	17,539	33,552	16,587	23,386	41,940	20,734	29,232
ICD 05-58	20,059	9,916	13,981	30,087	14,874	20,970	40,116	19,833	27,960	50,146	24,790	34,951
ICD 05-63	23,634	11,684	16,473	35,451	17,526	24,709	47,267	23,367	32,944	59,084	29,210	41,180
ICD 06-63	29,542	14,604	20,590	44,313	21,907	30,886	59,084	29,210	41,180	73,855	36,512	51,476
ICD 06-68	34,378	16,995	23,961	51,566	25,493	35,940	67,855	33,991	47,921	85,944	42,488	59,901
ICD 06-73	39,579	19,567	27,586	59,369	29,350	41,379	79,159	39,134	55,172	98,948	48,917	68,965

Spring Return (Fail closed or Fail open)

Unit : Nm

MODEL		Spring Torque			Air Torque : Air Supply Pressure											
					2.8 Bar			4.2 Bar			5.5 Bar			7 Bar		
		Start	R	End	Start	R	End	Start	R	End	Start	R	End	Start	R	End
ICR 02-20	4.2 Bar	817	459	683	601	176	78	1,243	493	525	1,885	811	973			
	5.5 Bar	1,061	595	883				1,043	358	281	1,685	675	729	2,327	992	1,176
ICR 02-25	4.2 Bar	1,276	713	1,055	951	279	122	1,955	774	822	2,958	1,270	1,527			
	5.5 Bar	1,683	942	1,396				1,614	546	415	2,617	1,042	1,114	3,620	1,538	1,813
ICR 02-30	4.2 Bar	1,855	1,035	1,526	1,363	393	159	2,808	1,107	1,165	4,252	1,821	2,172			
	5.5 Bar	2,582	1,445	2,141				2,192	698	439	3,637	1,412	1,446	5,081	2,126	2,452
ICR 02-35	4.2 Bar	2,277	1,247	1,776	1,826	534	234	3,628	1,425	1,489	5,429	2,315	2,745			
	5.5 Bar	3,139	1,750	2,574				2,830	922	627	4,631	1,812	1,882	6,432	2,703	3,138
ICR 03-35	4.2 Bar	2,711	1,512	2,230	2,008	583	243	4,128	1,630	1,720	6,247	2,678	3,197			
	5.5 Bar	3,759	2,098	3,093				3,265	1,045	671	5,384	2,093	2,148	7,503	3,140	3,625
ICR 03-38	4.2 Bar	3,641	1,973	2,759	2,838	794	261	5,637	2,178	2,212	8,436	3,561	4,162			
	5.5 Bar	4,737	2,643	3,897				4,500	1,508	1,115	7,298	2,891	3,066	10,097	4,275	5,016
ICR 03-43	4.2 Bar	4,379	2,437	3,577	3,570	1,096	601	7,143	2,862	3,092	10,716	4,628	5,582			
	5.5 Bar	6,099	3,403	5,017				5,702	1,896	1,372	9,275	3,663	3,863	12,848	5,429	6,353
ICR 04-43	4.2 Bar	6,093	3,327	4,716	4,573	1,266	382	9,218	3,562	3,619	13,863	5,859	6,857			
	5.5 Bar	7,878	4,301	6,098				7,837	2,588	1,835	12,482	4,884	5,072	17,127	7,181	8,310
ICR 04-48	4.2 Bar	7,605	4,152	5,887	5,662	1,557	444	11,436	4,412	4,468	17,210	7,266	8,493			
	5.5 Bar	10,017	5,469	7,754				9,579	3,095	2,056	15,343	5,949	6,081	21,117	8,804	10,105
ICR 04-53	4.2 Bar	9,164	5,004	7,094	6,958	1,943	630	13,984	5,417	5,527	21,011	8,890	10,424			
	5.5 Bar	11,864	6,478	9,183				11,895	2,842	2,827	18,921	7,416	7,724	25,947	10,890	12,621
ICR 05-53	4.2 Bar	11,329	6,213	8,879	8,416	2,337	725	17,063	6,612	6,752	25,711	10,887	12,779			
	5.5 Bar	15,018	8,235	11,770				14,173	4,590	3,064	22,820	8,865	9,091	31,467	13,140	15,118
ICR 05-58	4.2 Bar	13,008	7,133	10,195	10,484	3,089	1,404	20,823	8,201	8,611	31,162	13,312	15,817			
	5.5 Bar	18,316	10,044	14,355				16,663	5,290	3,303	27,003	10,402	10,510	37,342	15,513	17,716
ICR 05-63	4.2 Bar	15,733	8,628	12,331	12,034	3,417	1,248	24,216	9,440	9,739	36,398	15,462	18,230			
	5.5 Bar	20,512	11,232	16,008				20,539	6,836	4,961	32,721	12,859	13,451	44,904	18,881	21,942
ICR 06-63	4.2 Bar	18,928	10,292	14,480	15,976	4,764	2,299	31,204	12,293	12,913	46,431	19,821	23,526			
	5.5 Bar	26,335	14,028	18,967				26,717	8,556	5,505	41,945	16,085	16,119	57,173	23,613	26,732
ICR 06-68	4.2 Bar	23,156	12,591	17,715	17,726	4,930	1,545	35,446	13,690	13,896	53,167	22,451	26,247			
	5.5 Bar	30,708	16,357	22,115				31,046	9,924	6,345	48,766	18,685	18,695	66,486	27,445	31,046
ICR 06-73	4.2 Bar	26,132	14,209	19,992	20,812	5,963	2,307	41,214	16,049	16,527	61,615	26,135	30,746			
	5.5 Bar	34,753	18,512	25,029				36,176	11,746	7,905	56,578	21,832	22,125	76,979	31,918	36,345

< DOUBLE ACTING >

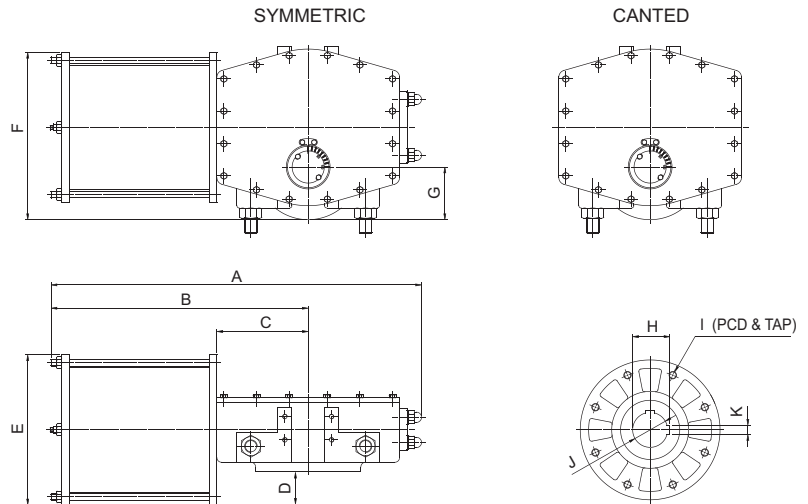

Symmetric IS Series Dimension

MODEL	A	B	C	D	E	F	G
ISD 02-20 (ISR)	755	516	196	48	272	370	145
ISD 02-25 (ISR)	755	516	196	73	322	395	145
ISD 02-30 (ISR)	755	516	196	98	373	420	145
ISD 02-35 (ISR)	755	516	196	117	410	445	145
ISD 03-35 (ISR)	935	653	236	92	410	490	175
ISD 03-38 (ISR)	935	653	236	118	461	505	175
ISD 03-43 (ISR)	935	653	236	143	512	530	175
ISD 04-43 (ISR)	1105	763	287	128	514	640	190
ISD 04-48 (ISR)	1105	763	287	153	564	657	190
ISD 04-53 (ISR)	1105	763	287	184	625	682	190
ISD 05-53 (ISR)	1310	904	343	157	625	710	230
ISD 05-58 (ISR)	1310	904	343	183	675	732	230
ISD 05-63 (ISR)	1310	904	343	210	730	760	230
ISD 06-63 (ISR)	1610	1124	415	192	745	830	260
ISD 06-68 (ISR)	1610	1124	415	217	795	850	260
ISD 06-73 (ISR)	1610	1124	415	243	847	875	260

Canted IC Series Dimension

MODEL	A	B	C	D	E	F	G
ICD 02-20 (ICR)	800	516	196	48	272	370	145
ICD 02-25 (ICR)	800	516	196	73	322	395	145
ICD 02-30 (ICR)	800	516	196	98	373	420	145
ICD 02-35 (ICR)	800	516	196	117	410	445	145
ICD 03-35 (ICR)	985	653	236	92	410	490	175
ICD 03-38 (ICR)	985	653	236	118	461	505	175
ICD 03-43 (ICR)	985	653	236	143	512	530	175
ICD 04-43 (ICR)	1215	763	295	128	514	640	205
ICD 04-48 (ICR)	1215	763	295	153	564	657	205
ICD 04-53 (ICR)	1215	763	295	184	625	682	205
ICD 05-53 (ICR)	1435	904	345	157	625	710	240
ICD 05-58 (ICR)	1435	904	345	183	675	732	240
ICD 05-63 (ICR)	1435	904	345	210	730	760	240
ICD 06-63 (ICR)	1710	1124	415	192	745	830	260
ICD 06-68 (ICR)	1710	1124	415	217	795	850	260
ICD 06-73 (ICR)	1710	1124	415	243	847	875	260



Susin Technologies Pvt. Ltd

No.4/134-A, K.N.G. Pudur Cross, Thadagam Road,
Coimbatore - 641 108. Tamilnadu, India
E-mail : info@susin.in Website : www.susin.in



Susin I-Tork (India) Pvt. Ltd

No.4/134-B, K.N.G. Pudur Cross, Thadagam Road,
Coimbatore - 641 108. Tamilnadu, India
E-mail : info@susinitork.in
Website : www.susinitork.in



Susin I-Tork ME., FZC

No.45, SAIF ZONE, P.B.No. 122643, SHARJAH, UAE
E-mail : info@susinitorkme.com
Website : www.susinitorkme.com



Susin Qatar Trading WLL

P.O.Box - 220, Doha, Qatar.
Email : technical@susinqatar.com
Website : susinqatar.com