

ROPER  WHITNEY.



AUTOBRAKE ®

 COMBI, SERIES

AB1014K



USA  MADE

ROPER  WHITNEY has been producing quality folding systems for a variety of markets. Building on that experience, the Autobrake integrates advanced design with the features that have made the Autobrake the choice of professionals.

The Autobrake combines the automation of bending angles, material clamping, and material support into a single CNC controlled system employing wing bending techniques.

Benefits of the Autobrake system vs. manual or press brake bending are:

- Reduced labor costs
- Improved part accuracy
- Reduced setup time
- Minimized tool changes
- Improved part quality especially on soft and pre-painted material

Construction

The Autobrake is a plate and weldment steel construction, delivering superior performance and features in a simplified rigid design. End housings are of plate construction bringing drive components close together for improved stiffness and performance. Actuating mechanisms are secured in rigid mounts at the outside of the housings, allowing easy maintenance.

The folding beam consists of a thick plate for maximum resistance to bending forces with a machined seat to receive the standard .787" (20mm), the thin .390" (10mm) or .250" (7mm) bending blade. A micrometer nut setting allows adjustment for large variations in material thickness. Actuating members rotate the bending beam into position from both ends of the machine, using a variable speed drive (VSD) for accurate control over programmed bend angles. Mechanisms are mounted within reinforced connections for improved performance.

The lower beam is a welded reinforced structure of fabricated steel. The lower beam is pinned in place, and coupled to the end housings for improved rigidity. The advanced design of this beam delivers superior hemming results.

The unique Kombi beam is a fabricated structural prism designed to withstand the forces generated by capacity forming operations. Machined into the Kombi beam 180° from each other are the attachment surfaces for the straight and box and pan tooling. Tools are attached to the Kombi beam with a quick change locking system to secure the tools even while the clamping bars are loosened for adjustment. A brake motor driving a sprocket and roller chain mechanism powers rotation of the Kombi beam. Access to the Autobrake's electrical system is located at the right-hand portion of the machine through a quick-lock enclosure. This enclosure houses the power and control devices that drive the machine, and extends behind the light-hand cover for reduced machine length.

Material Sensing Clamping

Clamping pressure exerted by the upper beam is variable to accommodate a wide variety of materials, thicknesses and finishes. Clamping and hemming pressures are programmable, so no tool change is required to create open, closed, or tear drop hems. The positioning of the upper beam is controlled by a closed loop circuit. The upper beam is driven to a programmed setting by a brake motor and eccentric drive of the beam with a connecting shaft. Clamping and hemming power is delivered to the clamp jaws by a series of spring washers to provide variable clamping pressures with a shock-absorbing end stop. This provides reliable clamping pressure regardless of material thickness. Integral to the upper beam are the ways with non-metallic gibing to guide and retain the upper beam within the end housings.

Kombi Beam Tooling

The upper beam comes standard with both segmented and sharp rail tooling. The segmented box tooling can form boxes with a maximum depth of 4.0". The sharp rail tooling is machined to 30°.

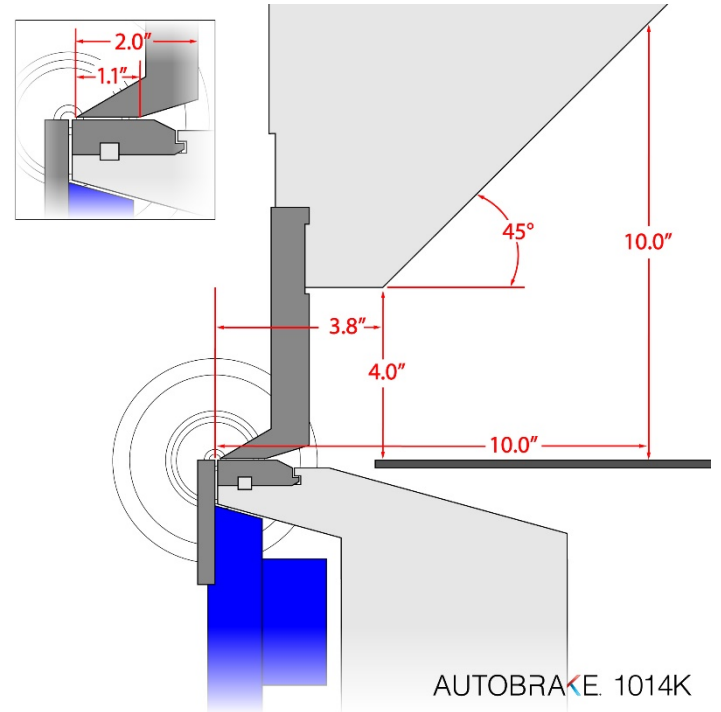
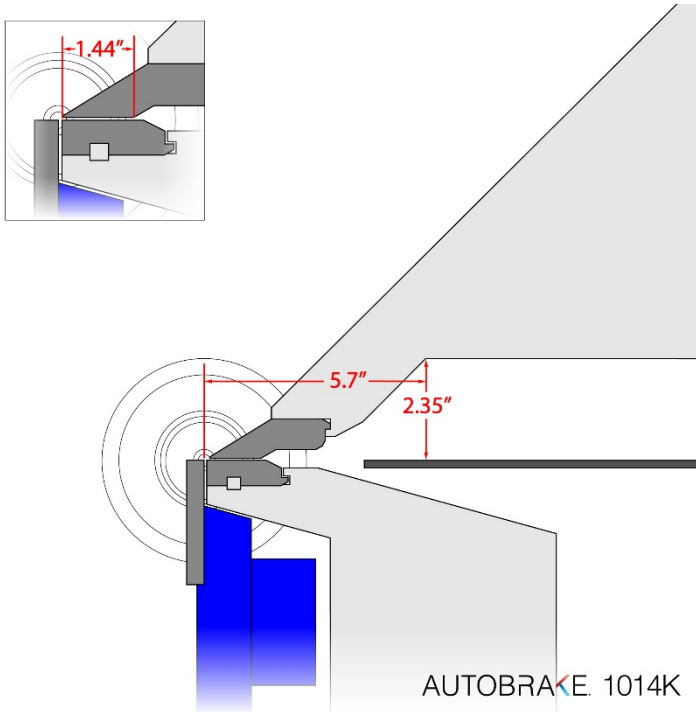

Crowning

Manual crowning of the folding beam is standard on all Autobrakes. The system provides a quick easy method for adjusting the crown of the bending tool and eliminates the need for shimming. The ability to adjust crowning of the tool, improves bend accuracy, material straightness, radius bends, and the forming of cornice work. This system consists of crowning cams, actuating tool, and is manually adjusted, and locked in place by the operator.



Integrated Sheet Support and Material Positioning

Work pieces are fully supported by the back gauge table beneath the clamping beam, and automatically positioned to an accuracy of +/- .004". The back gauge is positioned by a servo motor capable of moving 0.250" to 61" in less than 3 seconds. Nine conveniently spaced fingers provide positive contact with the sheet edge at all times and the fingers will travel down to 0.250" position. Maximum back gauge travel can be reached in less than 3 seconds using a three stage design combining high speed with compact space requirements. The operation of the pop-up back gauge fingers is controlled pneumatically. The back gauge is capable supporting sheets up to 700lb. (318kg). The standard back gauge depth is 61" with optional 122" depths.



The back gauge can be expanded with the addition of optional extensions, providing greater gauging depth, and allowing the formation of large work products. Extension systems attach to the standard back gauge provided with the Autobrake, and utilize the alignment features and accuracies already inherent in the 61" back gauge. The extension can be joined with the standard 61" back gauge to create an L-shape, J-shape or combined to form a U-shaped gauging systems providing material positioning to 122". A max 122" of back gauge travel is achieved in less than 3 seconds, allowed by the 6-stage stop design combining high speed with compact space requirement.

Intelligent Controls

Synergy is the latest software designed for Roper Whitney's line of powered folding machines. It is a highly advanced CNC system that takes the complexity out of programming and running parts. Easily control and view all of the machines motions with the intuitive interface. The full-color, graphic touchscreen makes it simple to draw, store and browse and for parts. The software also brings together information from the office-based Konstruct program and the field-based Konstruct Mobile with Roper Whitney's technical support program Konnect.

- Windows 8.1 imbedded industry pro.
- Automatic sequencing of the part that is drawn.
- Possibility of saving programs in folders and subfolders.
- 3D Part display.
- Part simulation to verify bends sequence, material handling and collisions.
- A search function is used to make it easier to identify a part.
- Export of programs, library materials and back up to USB stick.
- The actual values of the axis are shown on the display, as well as the motion of the machine in real time.
- There are 3 different hems: Open Closed or Tear Drop.
- Capable of importing DXF files.
- Konstruct offline programming
- Konnect online service and operator assistance.

With Synergy you have the option to purchase Konstruct. The Synergy software brings together information from the office-based Konstruct program and the field-based Konstruct Mobile with Roper Whitney's technical support program Konnect.

Automatic Bend Sequence Calculations

The bending sequence is calculated and optimized in relation to the characteristics of the piece and the actual measurements of the machine and the accessories mounted. It is possible to establish and /or modify the bending sequence calculated by the software, once "customized", the software saves the new sequence and uses it as a first option for the following similar profiles. In the illustration of the bending sequence and simulation, there are icons that show how to insert, rotate and flip the sheet.

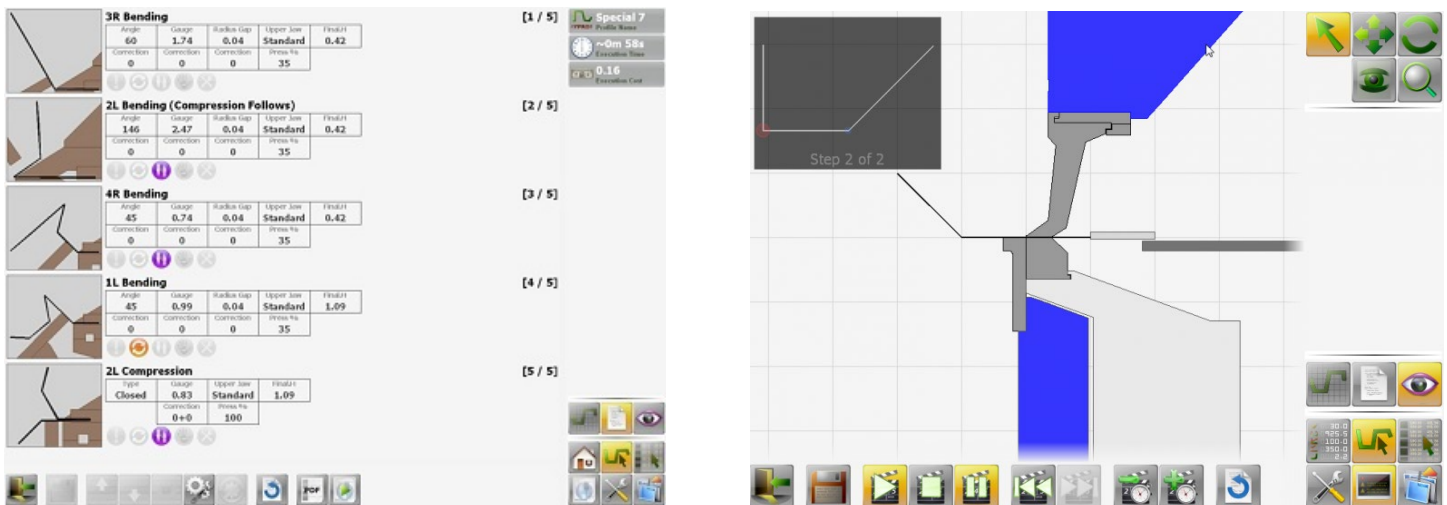

The Synergy control calculates the stretch out of the part as well as the notch pattern of boxes.



Simple, reliable, intuitive and precise. Entering data directly on the screen, if errors occur, you cancel your choice with a click (button "undo" or "redo"). The profile can be drawn, edited and saved directly on the screen (touch screen mode) and data, such as length; angle and radius can also be entered manually, by selecting the affected side.

Graphical user interface complete with zoom, rotation, displacement, vertical and horizontal with a simple touch on the screen. Folds, round profiles, hems, and steps are inserted using the appropriate button and touching the screen like a blackboard on which to draw.

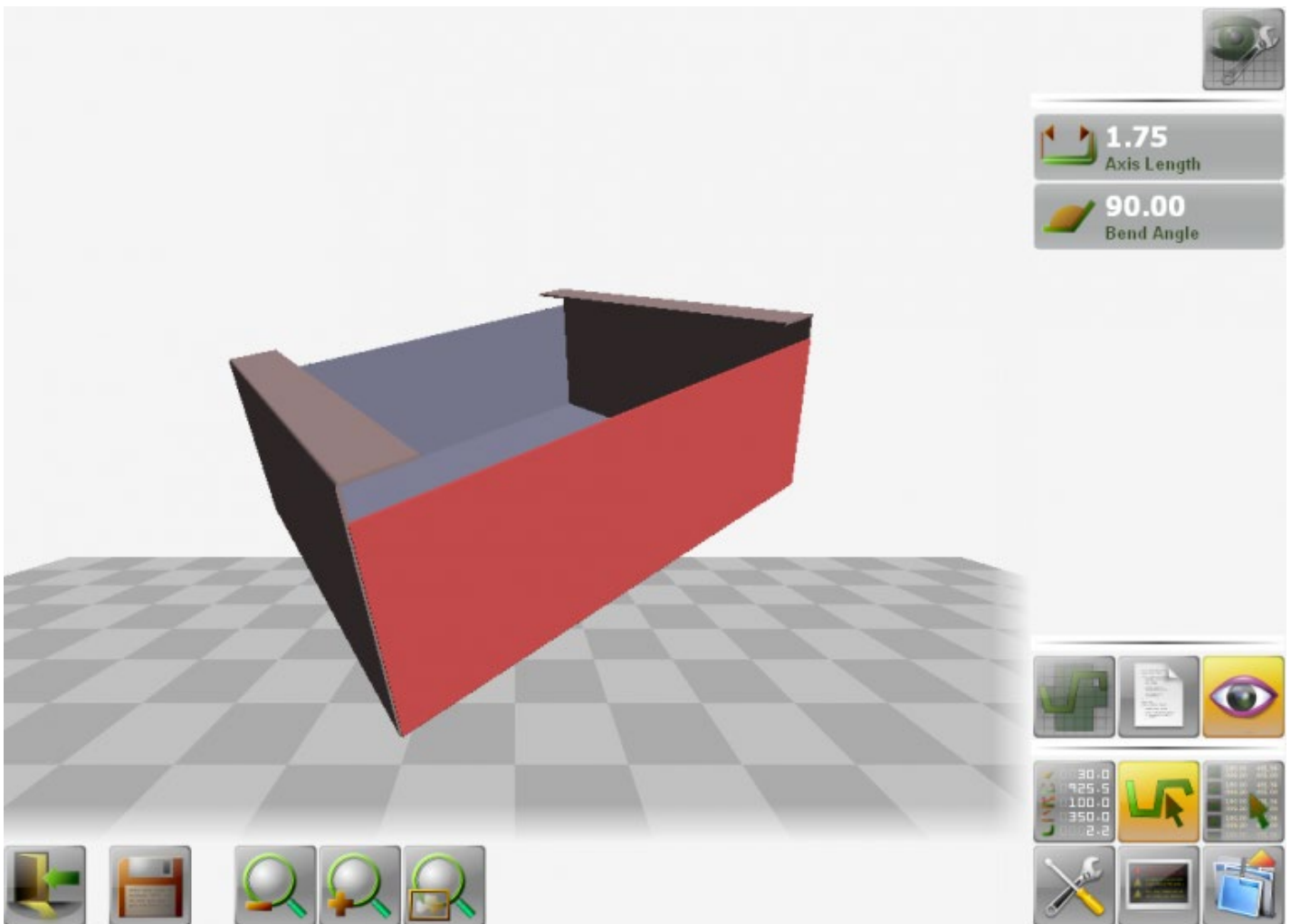



You've seen this play out over and over you're on site and you realize you're missing a part. You sketch it out and send a driver to your fabrication shop. The driver makes the trip, waits while your operator fabricates the part, then hustles back to the site. Efficient? Hardly. There is a better way. We call it Konstruct.

Konstruct is an innovative software package created and used exclusively by Roper Whitney. This in-office software package allows the office to communicate directly with the Synergy control on your machine. From the office the administrator can create, manage and monitor the activities on the folding machines.



Greater Control

Parts are created the same way as they would be on the machine. It is as simple as drawing the shape with the correct angles and dimensions and the software does the rest.

The part is then automatically sequenced so that the proper bend order is followed. The type of material, number of pieces and any other information is entered and the job is ready to be run.

The administrator can then see what jobs are waiting to be run, what is in process and what has been completed giving you greater control over your shop processes.

- Create or manage jobs
- Easy Window based navigation
- Create job list for each folder in your shop
- Real time knowledge of what jobs have been completed
- DXF file import capability



Konstruct Mobile is the “in-the-field” version of the Synergy software that operates the Autobrake and Automax folders. Using Konstruct Mobile on a mobile phone, tablet or laptop you can design, price and order parts remotely from anywhere you have an internet connection and communicate that directly back to your Konstruct office software. Its efficiency that you will appreciate, and it’s a selling tool that you as a fabricating contractor, can use over competition in service and sales.



From the job site you can instantly tell the office what type of material, color, thickness and number of pieces you require. Once a part is sent to the office the job will be automatically reviewed to confirm that it can be run on the machine. As parts are created they can be stored and accessed again at a later date. The Konstruct Mobile software package can be used by your customers in place of sending pictures or hand sketched drawings so parts are drawn with accurate angles and dimensions.

Create, Spec and Order Parts from the Field

- Choose parts from a part library or create your own
- Simple part drawing
- Send orders from any mobile device
- Pick color, type of material and number of pieces
- Enter job name or PO#

Real-Time Support with Maximum Up-time

With Konnect you can receive real-time support for your folder directly from our service team. Our technical experts can remotely diagnose and correct most issues that may occur to help you avoid costly down-time.

Features include:

- Live audio and video on your equipment's control system
- Diagnose machine problems quickly to help you avoid down-time
- Eliminate travel costs for onsite, in-person service calls and maintenance
- Share your machine's control system so we can make necessary updates remotely
- Receive follow-up training or programming assistance



Roper Whitney Service Department



Your Machine

Autobrake AB1014K	
Bending Capacity (Mild Steel)	14ga / 2,0mm
Bending Capacity (Stainless)	16ga / 1,5mm up to 90°, 18ga / 1,2mm past 90°
Bending Length	122 in / 3100mm
Bending Bars	.787" (20mm) bending bar x 122" (3100mm) .394" (10mm) bending bar x 122" (3100mm) .275" (7mm) bending bar x 122" (3100mm)
Crowning of the Folding Beam	5-Point 0"-0.030" Adjustment
Folding Beam Adjustment	2 in / 50mm
Clamping Beam Opening Height	7 in / 178mm
Clamping Beam Tooling Straight Rail	30 Degrees
Kombi Beam Segment Tooling (Max Box Depth)	4 Inches / 101mm
Back gauge Depth (Standard)	61 in / 1550 mm
Working Height	34 in / 864mm
Back Gauge Motor	3/4 hp Servo / 0.6 kw Servo
Clamping Beam Motor	2 hp / 1.5 kw
Clamping Beam Rotation Motor	1 hp / 0.75 kw
Bending Beam Motor	2 hp / 1.5 kw
Machine Weight	8,550 lbs. / 3886 kg
Shipping Weight	9,050 lbs. / 4114 kg
Machine Dimensions	160 x 90 x 84 in / 4064 x 2286 x 2134 mm
Speed	AB1014K
Clamping Beam Speed	2.5" per second
Folding Beam Speed	70 degrees per second
Back gauge Speed (0.250" to 61")	2 seconds

Machines are standard with 220 Volt 3 Phase 60 Hz electrics

*A CNC PAC-10 rotary phase converter is required when connecting to single phase power.



USA  MADE