



USATF™

2026 COMPETITION RULES

Track & Field
Long Distance Running
Race Walking

Open
U20
Youth
Masters

Rules Editor

John C. Blackburn

Associate Rules Editors

Bob Podkaminer, Karen Krsak,
Dan Pierce, Raymond Pierre,
Matthew Chestnut, Marty Johnson, Duke Fuller

Copyright ©2026

An official publication of USA Track & Field
342 Massachusetts Avenue
Indianapolis, IN 46204

317-261-0500 | Fax 317-261-0514 | www.usatf.org

USA Track & Field is the National Governing Body for track and field, long distance running and race walking, and is the United States member of World Athletics

2026

January						
S	M	T	W	T	F	S
				1	2	3
4	5	6	7	8	9	10
11	12	13	14	15	16	17
18	19	20	21	22	23	24
25	26	27	28	29	30	31

February						
S	M	T	W	T	F	S
1	2	3	4	5	6	7
8	9	10	11	12	13	14
15	16	17	18	19	20	21
22	23	24	25	26	27	28

March						
S	M	T	W	T	F	S
1	2	3	4	5	6	7
8	9	10	11	12	13	14
15	16	17	18	19	20	21
22	23	24	25	26	27	28
29	30	31				

April						
S	M	T	W	T	F	S
			1	2	3	4
5	6	7	8	9	10	11
12	13	14	15	16	17	18
19	20	21	22	23	24	25
26	27	28	29	30		

May						
S	M	T	W	T	F	S
					1	2
3	4	5	6	7	8	9
10	11	12	13	14	15	16
17	18	19	20	21	22	23
24	25	26	27	28	29	30
31						

June						
S	M	T	W	T	F	S
	1	2	3	4	5	6
7	8	9	10	11	12	13
14	15	16	17	18	19	20
21	22	23	24	25	26	27
28	29	30				

July						
S	M	T	W	T	F	S
			1	2	3	4
5	6	7	8	9	10	11
12	13	14	15	16	17	18
19	20	21	22	23	24	25
26	27	28	29	30	31	

August						
S	M	T	W	T	F	S
						1
2	3	4	5	6	7	8
9	10	11	12	13	14	15
16	17	18	19	20	21	22
23	24	25	26	27	28	29
30	31					

September						
S	M	T	W	T	F	S
		1	2	3	4	5
6	7	8	9	10	11	12
13	14	15	16	17	18	19
20	21	22	23	24	25	26
27	28	29	30			

October						
S	M	T	W	T	F	S
				1	2	3
4	5	6	7	8	9	10
11	12	13	14	15	16	17
18	19	20	21	22	23	24
25	26	27	28	29	30	31

November						
S	M	T	W	T	F	S
1	2	3	4	5	6	7
8	9	10	11	12	13	14
15	16	17	18	19	20	21
22	23	24	25	26	27	28
29	30					

December						
S	M	T	W	T	F	S
		1	2	3	4	5
6	7	8	9	10	11	12
13	14	15	16	17	18	19
20	21	22	23	24	25	26
27	28	29	30	31		

2027

January						
S	M	T	W	T	F	S
					1	2
3	4	5	6	7	8	9
10	11	12	13	14	15	16
17	18	19	20	21	22	23
24	25	26	27	28	29	30
31						

February						
S	M	T	W	T	F	S
	1	2	3	4	5	6
7	8	9	10	11	12	13
14	15	16	17	18	19	20
21	22	23	24	25	26	27
28						

March						
S	M	T	W	T	F	S
	1	2	3	4	5	6
7	8	9	10	11	12	13
14	15	16	17	18	19	20
21	22	23	24	25	26	27
28	29	30	31			

April						
S	M	T	W	T	F	S
				1	2	3
4	5	6	7	8	9	10
11	12	13	14	15	16	17
18	19	20	21	22	23	24
25	26	27	28	29	30	

May						
S	M	T	W	T	F	S
						1
2	3	4	5	6	7	8
9	10	11	12	13	14	15
16	17	18	19	20	21	22
23	24	25	26	27	28	29
30	31					

June						
S	M	T	W	T	F	S
		1	2	3	4	5
6	7	8	9	10	11	12
13	14	15	16	17	18	19
20	21	22	23	24	25	26
27	28	29	30			

July						
S	M	T	W	T	F	S
				1	2	3
4	5	6	7	8	9	10
11	12	13	14	15	16	17
18	19	20	21	22	23	24
25	26	27	28	29	30	31

August						
S	M	T	W	T	F	S
1	2	3	4	5	6	7
8	9	10	11	12	13	14
15	16	17	18	19	20	21
22	23	24	25	26	27	28
29	30	31				

September						
S	M	T	W	T	F	S
			1	2	3	4
5	6	7	8	9	10	11
12	13	14	15	16	17	18
19	20	21	22	23	24	25
26	27	28	29	30		

October						
S	M	T	W	T	F	S
					1	2
3	4	5	6	7	8	9
10	11	12	13	14	15	16
17	18	19	20	21	22	23
24	25	26	27	28	29	30
31						

November						
S	M	T	W	T	F	S
	1	2	3	4	5	6
7	8	9	10	11	12	13
14	15	16	17	18	19	20
21	22	23	24	25	26	27
28	29	30				

December						
S	M	T	W	T	F	S
			1	2	3	4
5	6	7	8	9	10	11
12	13	14	15	16	17	18
19	20	21	22	23	24	25
26	27	28	29	30	31	

2028

January						
S	M	T	W	T	F	S
						1
2	3	4	5	6	7	8
9	10	11	12	13	14	15
16	17	18	19	20	21	22
23	24	25	26	27	28	29
30	31					

February						
S	M	T	W	T	F	S
		1	2	3	4	5
6	7	8	9	10	11	12
13	14	15	16	17	18	19
20	21	22	23	24	25	26
27	28	29				

March						
S	M	T	W	T	F	S
			1	2	3	4
5	6	7	8	9	10	11
12	13	14	15	16	17	18
19	20	21	22	23	24	25
26	27	28	29	30	31	

April						
S	M	T	W	T	F	S
						1
2	3	4	5	6	7	8
9	10	11	12	13	14	15
16	17	18	19	20	21	22
23	24	25	26	27	28	29
30						

May						
S	M	T	W	T	F	S
	1	2	3	4	5	6
7	8	9	10	11	12	13
14	15	16	17	18	19	20
21	22	23	24	25	26	27
28	29	30	31			

June						
S	M	T	W	T	F	S
				1	2	3
4	5	6	7	8	9	10
11	12	13	14	15	16	17
18	19	20	21	22	23	24
25	26	27	28	29	30	

July						
S	M	T	W	T	F	S
						1
2	3	4	5	6	7	8
9	10	11	12	13	14	15
16	17	18	19	20	21	22
23	24	25	26	27	28	29
30	31					

August						
S	M	T	W	T	F	S
		1	2	3	4	5
6	7	8	9	10	11	12
13	14	15	16	17	18	19
20	21	22	23	24	25	26
27	28	29	30	31		

September						
S	M	T	W	T	F	S
					1	2
3	4	5	6	7	8	9
10	11	12	13	14	15	16
17	18	19	20	21	22	23
24	25	26	27	28	29	30

October						
S	M	T	W	T	F	S
1	2	3	4	5	6	7
8	9	10	11	12	13	14
15	16	17	18	19	20	21
22	23	24	25	26	27	28
29	30	31				

November						
S	M	T	W	T	F	S
			1	2	3	4
5	6	7	8	9	10	11
12	13	14	15	16	17	18
19	20	21	22	23	24	25
26	27	28	29	30		

December						
S	M	T	W	T	F	S
					1	2
3	4	5	6	7	8	9
10	11	12	13	14	15	16
17	18	19	20	21	22	23
24	25	26	27	28	29	30
31						

NOTES

NOTES

USATF National Headquarters

342 Massachusetts Avenue
Indianapolis, IN 46204

Main Switchboard: 317-261-0500
Main Fax: 317-261-0481
www.usatf.org

World Athletics (formerly IAAF)

6-8, Quai Antoine 1er,
BP359, MC 98007 Monaco Cedex

Tel: +377 93 10 88 88
Fax: +377 93 15 95 15
www.worldathletics.org

United States Olympic & Paralympic Committee (USOPC)

One Olympic Plaza
Colorado Springs, CO 80909

719-632-5551
Fax 719-578-4654
www.teamusa.org

United States Anti-Doping Association (USADA)

5555 Tech Center Drive, Suite 200
Colorado Springs, Colorado 80919-2372

www.usada.org
719-785-2000
Toll Free 866-601-2632
Fax 719-785-2001
Hotline 800-233-0393

USATF ARTICLE 5-C MEMBER ORGANIZATIONS

National Association of Intercollegiate Athletics (NAIA)

1200 Grand Blvd.
Kansas City, MO 64106

816-595-8000
Fax 816-595-8200
www.naia.org

National Collegiate Athletic Association (NCAA)

PO Box 6222
Indianapolis, IN 46206-6222

317-917-6222
Fax 317-917-6888
www.ncaa.org

National Federation of State High School Associations (NFHS)

PO Box 690
Indianapolis, IN 46206-0690

317-972-6900
Fax 317-822-5700
www.nfhs.org

National Junior College Athletic Association (NJCAA)

c/o Scottsdale Community College
9000 E. Chaparral Road
Scottsdale, AZ 85256-2626

480-423-6616
Fax 480-423-6663
www.njcaa.org

Road Runners Club of America (RRCA)

1501 Lee Highway, Suite 140
Arlington, VA 22209

703-525-3890
Fax 703-525-3891
www.rrca.org

Running USA (RUSA)

PO Box 1988
Colorado Springs, CO 80901

719-434-2575
www.runningusa.org

USATF ARTICLE 5-D MEMBER ORGANIZATIONS

All American Trail Running Association (AATRA)

PO Box 9454
Colorado Springs, CO 80932

Office 719-573-4405
www.trailrunner.com

Amateur Athletic Union (AAU)

AAU National Headquarters
PO Box 22409
Lake Buena Vista, FL 32830

Office 407-934-7200
Fax 407-934-7242
www.aausports.org

American Ultrarunning Association (AUA)

4 Strawberry Lane
Morristown, NJ 20814

973-898-1261
aua@americanultra.org

National Scholastic Athletics Foundation (NSAF) www.nationalscholastic.org

91 Nahatan Street
Westwood, MA 02090

info@nationalscholastic.org

National Senior Games Association (NSGA)

3204 Gulf to Bay Blvd
Clearwater, FL 33759

225-766-6800
Fax 225-766-9115
www.nsga.com

U.S. Armed Forces Sports (USAF)

2405 Gunshed Road
Fort Sam Houston, TX 78234

210-466-1336
armedforcessports.defense.gov

United States Corporate Athletics Association (USCAA)

844 Racquet Lane
Boulder, CO 80303

303-494-0107
holtzgard2@aol.com

U.S. Meet Directors Association (USMDA)

YMCA of the USA (YMCA)

101 N. Wacker Dr.
Chicago, IL 60606

800-872-9622
312-977-0031
Fax 312-977-9063

www.ymca.net

TABLE OF CONTENTS

ARTICLE I Championship Events and USA Olympic Team Selection

SECTION I GENERAL

	Rule	Page
National Championships	1	9
Regional Championships	2	10
Association Championships	3	11
Eligibility for Team Championships	4	11
Awards	5	12
General	6	13
Team Scoring	7	14
Automatic Qualification	8	15
Non-Championship Competitions	9	16

SECTION II

MEN'S AND WOMEN'S TRACK AND FIELD CHAMPIONSHIPS

Outdoor Track and Field Championships	10	18
Indoor Track and Field Championships	11	20
National Track and Field Club Championships	12	22
Other Championships	13	23
Transferring Membership Prior to Championships	14	24

SECTION III

CROSS COUNTRY & LONG DISTANCE RUNNING CHAMPIONSHIPS

Men's and Women's Cross Country Championships	15	25
Long Distance Running Championships - Men	16	26
Long Distance Running Championships - Women	20	27
Mountain, Ultramarathon and Trail Championships	21	28

SECTION IV

RACE WALKING CHAMPIONSHIPS

Championship Events - Men and Women	25	29
-------------------------------------	----	----

SECTION V

OLYMPIC TEAM SELECTION

U.S. Olympic Selection	27	30
------------------------	----	----

ARTICLE II

MEDICAL SERVICES AND DOPING CONTROL

Doping	32	31
Athlete Fitness and Waiver	49	31

ARTICLE III

Officials

Meet Personnel	110	32
Games Committee	111	34
Photo Finish Operator	118	34
Jury of Appeal	119	34
Technical Manager	123	35
Event Presentation Manager	124	36
Referee	125	36
Judges	126	38
Umpires	127	40
Timers, Photo Finish Judges, Transponder Timing Judges	128	40
Starter and Recall Starter	129	42
Starter's Assistant / Line Clerk	130	43
Lap Scorers	131	44
Competition Secretary/Technical Information Center (TIC)	132	44
Marshal	133	45
Wind Gauge Operator	134	45
Electronic Measurement Judge	135	46
Clerk of Course / Call Room	136	46
Additional Officials	139	47
Competition Area	140	47

ARTICLE IV

Rules of Competition

SECTION I

GENERAL

Classifications	141	48
Competitor Check-In	142	49
Athletic Attire	143	50
Assistance to Athletes	144	52
Disqualification	145	56
Protests	146	56
Mixed Competition	147	59
Surveying, Measurements and Weights	148	59
Validity of Performance	149	60
Video Recording	150	61
Correctable Error	158	61
Electronic Devices	159	61
Track Lanes and Measurements	160	61
Starting Blocks	161	63
The Start	162	64
The Competition	163	68
The Finish Line	164	71
Timing	165	72

**SECTION II
TRACK EVENTS**

Regulations for Forming Heats	166	77
Running Event Ties	167	84
Hurdles	168	84
Steeplechase	169	87
Relay Races	170	88

**SECTION III
FIELD EVENTS**

General Rules	180	92
High Jump and Pole Vault	181	99
High Jump	182	104
Pole Vault	183	105
Horizontal Jump	184	106
Long Jump	185	107
Triple Jump	186	108
Throwing Events-General Rules	187	109
Putting the Shot	188	114
Throwing the Discus	189	115
Hammer, Discus, and Weight Throwing Cage	190	116
Throwing the Hammer	191	116
Throwing the Javelin	193	117
Throwing the Weight	195	121
The Ultraweight	196	123

**SECTION IV
COMBINED EVENTS**

Events - General Rules	200	125
Throws Pentathlon	201	128
Throw-A-Thon	202	129
Ultraweight Pentathlon	203	129

Section V

Indoor and Short Track Competitions

Applicability of Indoor Rules	210	131
Indoor Stadium / Short Track	211	131
Track Lanes & Measurement	212	131
Regulations for Forming Heats	214	132
Shoes	216	13
Hurdles	217	135
Relay Races	218	135
High Jump	219	136
Pole Vault	220	136
Horizontal Jumps	221	136
Shot Put/Weight Throw	222	136
Combined Events	223	137

**SECTION VI
RACE WALKING**

Judges of Race Walking	230	138
Race Walking Officials	231	140
General Rules	232	140

**SECTION VII
LONG DISTANCE AND ROAD EVENTS RUNNING AND WALKING**

Course Certification	240	143
Medical and Refreshment Services for Road Events	241	143
Starting a Running Event	242	144
Course Marking and Monitoring	243	145
The Finish Line	244	146
Scoring Running Events	246	147

**SECTION VIII
CROSS COUNTRY, MOUNTAIN AND TRAIL RUNNING**

General	250	148
Cross Country	251	148
Mountain and Trail Running	252	149

**ARTICLE V
Records**

World Records	260	152
National Records	261	153
Rules Applicable to All Records	262	154
Rules Applicable to Track Events	263	156
Rules Applicable to Field Events	264	158
Rules Applicable to Long Distance Running Events	265	158
Rules Applicable to Race Walking Events	266	159
Events in Which Records Are Recognized	267	161
Additional Records	268	165
Noteworthy Performances	269	165

**ARTICLE VI
Special Programs
SECTION I
YOUTH ATHLETICS**

General Rules	300	166
Track and Field Events	301	170
Regulations and Specifications	302	171
Regulations for Lanes and Heats	303	177
National Cross Country Program	304	180
Indoor Championship	305	181
Junior Olympic Program	306	182
Special Events and Programs	307	185

SECTION II
MASTERS ATHLETICS

General Rules	320	189
---------------	-----	-----

SECTION II -A
MASTERS TRACK AND FIELD AND RACEWALKING

General Rules	330	190
Masters Track and Field Championships	331	190
Competitive Rules and Standards for Masters Track and Field	332	192
Masters Race Walking Championships	333	198

SECTION II -B
MASTERS LONG DISTANCE RUNNING

General Rules	340	200
Masters Long Distance Championships	341	200

APPENDICES

Appendix 1: Illustrations	202
Appendix 2: Record Application	212
Appendix 3: Para Athlete Rule Adaptation	218
Appendix 4: World Athletics/IAAF Rule Cross References	

EDITOR'S NOTE

The rules applicable to domestic competition in Athletics -- track and field, race walking, road running and cross country -- are approved by USA Track & Field. These rules generally conform to those of World Athletics (formerly IAAF). Amendments to USA Track & Field's rules may be adopted at its Annual Meeting, based upon the recommendations of its Rules Committee. Inquiries regarding USATF or World Athletics rules of competition may be addressed to the undersigned.

John C. Blackburn, Chair, Rules Committee

CHAIR

John C. Blackburn 843-814-2907 john@speedfish.com

VICE CHAIR

Dan Pierce 303-931-4690 dptrack@gmail.com

SECRETARY

Bob Podkaminer 707-696-6838 rpodkam@aol.com

Jeff Bauer Jeffbauer95@gmail.com

Rich Benoy 310-748-7650 rbenoy1323@yahoo.com

Tom Bernhard tlbernhard2@gmail.com

Laurie Boemker lboemker@gmail.com

Richard Boyd usatfindianaboyd@gmail.com

Julie Cochran jcochran@nfnhs.org

Kenny Emerick 206-361-2234 ken123e@aol.com

Phil Greenwald 917-349-8432 greenwaldp@worldnet.att.net

Jeff Hartwig 870-926-3440 pvjeff@gmail.com

Tiombe Hurd

Martin Johnson 719-209-1892 martin.d.johnson@att.net

David Katz 516-883-5599 katz@flrrt.com

Mark Kostek kostekmt@gmail.com

Karen Krsak track1249@gmail.com

Bill McKee 918-832-9820 usatfok@aol.com

Dennis Mitchell dwmitch4@illinois.edu

Steve Mullaney gone2ski@bellsouth.net

Sandy Pashkin spashkin66@gmail.com

Raymond Pierre 254-722-3903 raymondpierre@sbcglobal.net

Patrick Pretty papret@execpc.com

Betsy Reed careed27@gmail.com

Alcmena Monique White 610-585-7816 moose7_89@yahoo.com

SUMMARY OF 2026 RULE CHANGES

A summary of changes adopted by USATF at its 2025 Annual meeting in Orlando, FL

Rule	Amendment
8	Clarify defending champion for automatic qualification
10.4, 13.1, 136.1, 136.3, 142.2	Require publication of Call Room Schedule
15	Updates to Cross Country Championship
25, 267	Add Half-Marathon and Marathon as Champ and record RW distances and update penalty zone times
125.6	Encourage consensus rulings by Referees
125.15	Include authority for Referee to decide on accommodations for Para athletes.
126.9	Modification to Javelin landing judges reporting
128	Adopt WA reference to Photo Finish rather than Fully Automatic Timing
141.2	New Rule specifying Female category
146.2	Protest time limit begins at end of each round
162.5	Update sound levels for electronic starting device
162.17	Expand and describe resources to determine false starts
166	Updates to preferred lane
168.1, 260	Add 300m hurdles as Open event and record event. This is different from the US HS 300m hurdle event.
168.3	Update to description and effect of displacing hurdle as infringement
170.5	Emphasize the authority of Umpire to remove improper relay marks, and specifically allow athletes to tear a single piece of tape for their mark.
170.16	No substances allowed on batons Clarify allowed actions to retrieve a dropped baton
170.26, 267	Add 4x100 mixed relay with order specified as Male/Female/Male/Female
181.6	Align vertical jump rules more closely to WA
193.5	New specifications for 700g Javelin
200.12	Gunderson scoring method has been deleted
212	Updated requirements for Short Track performances
243, 252	Updates to some terminology and event titles in MUT
267	Add 4 Mile as LDR record distance
303	Aero Javelin is the implement for 9-10 and 11-12 Divisions

Amended language is indicated throughout the Rule Book by **shading**
Where WA updated language as a stylist change, these are marked by **green shading**

**ARTICLE I
CHAMPIONSHIPS AND OLYMPIC TEAM SELECTION**

**SECTION I
GENERAL**

**RULE 1
NATIONAL CHAMPIONSHIPS**

1. Eligibility:
 - (a) In the Open Men's and Women's Indoor and Outdoor Track and Field Championships, the U20 (formerly Junior) Men's and Women's Track and Field Championships, the Men's and Women's Race Walking Championships, the Men's and Women's Open, U20, and Masters Cross Country Championships, and the Men's and Women's Long Distance Running Championships, only citizens of the United States who are eligible to represent the United States in all levels of international competition are eligible to compete. (In the Men's and Women's Race Walking Championships, Men's Long Distance Running Championships, and Masters Cross Country Championships, others may compete in a separate non-scoring division or race.)
 - (b) In addition, in Long Distance Running and Race Walking, US citizens who are not eligible to represent the USA in International competition are allowed to participate in any USA National Championship that is not the sole selection event for an international team.
 - (c) The Masters Track and Field Championships are open to all member athletes of USATF or of other World Athletics member federations.
 - (d) The Masters Long Distance Running Championships are open to all member athletes of USATF, including Permanent Residents. However, only U.S. citizens shall be awarded individual championship awards or score for a team.
 - (e) The Youth Athletics Championships are open to all member athletes of USATF, including aliens living in the United States and foreign exchange students.
 - (f) The Club Track and Field Championships are also open to Permanent Residents (green card holders).

NOTE: *Double leg amputees competing in USATF open events must comply with the WPA Measurement Assessment of Standing Height (MASH).*
2. Non-resident alien athletes, unless otherwise provided in these rules, may compete as invited guests only on a reciprocal basis. They may not displace otherwise qualified USATF member athletes for national titles, team scoring, and championship awards. When possible, a US citizen shall be added to the finals if displaced by a non-US citizen.
3. When a National Championship is used as a selection meet for an international competition, a Sport Committee may permit competition in the National Championship by a non-US citizen if the Sport Committee has been provided with proof that the competitor will acquire eligibility to represent the United States after the Championship but prior to the international competition.

RULE 2
REGIONAL CHAMPIONSHIPS

1. Regional Championships may be annually conducted.
2. For Open and U20 Championships, except Cross Country and Race Walking, the Regions will comprise Associations as follows:

Region	Association
East	Adirondack, Connecticut, Long Island, Maine, Mid-Atlantic, New England, New Jersey, New York, Niagara, Virginia, Potomac Valley, and Three Rivers
South	Alabama, Arkansas, Florida, Georgia, Gulf, North Carolina, Oklahoma, Southern, South Texas, Southwestern, South Carolina, Tennessee, and West Texas
North	Dakotas, Illinois, Indiana, Iowa, Kentucky, Lake Erie, Michigan, Ohio, Ozark, Minnesota, Missouri Valley, Nebraska, West Virginia, and Wisconsin
West	Alaska, Arizona, Border, Central California, Colorado, Hawaii, Inland Northwest, Montana, Nevada, New Mexico, Oregon, Pacific, Pacific Northwest, San Diego Imperial, Snake River, Southern California, Utah, and Wyoming

3. For Open and U20 Cross Country, Open and U20 Race Walking and all Masters Championships, the Regions will comprise Associations as follows:

Region	Associations
East	Adirondack, Connecticut, Long Island, Maine, Mid-Atlantic, New England, New Jersey, New York, Niagara, Potomac Valley, and Three Rivers
Southeast	Alabama, Florida, Georgia, North Carolina, South Carolina, Tennessee, and Virginia
Midwest	Illinois, Indiana, Kentucky, Lake Erie, Michigan, Ohio, West Virginia, and Wisconsin
Mid-America	Colorado, Dakotas, Iowa, Minnesota, Missouri Valley, Nebraska, and Ozark
Southwest	Arkansas, Border, Gulf, Oklahoma, Southern, South Texas, Southwestern, and West Texas
Northwest	Alaska, Inland Northwest, Montana, Oregon, Pacific Northwest, Snake River, Utah, and Wyoming
West	Arizona, Central California, Hawaii, Nevada, New Mexico, Pacific, San Diego-Imperial, and Southern California.

4. For the definition of the Youth Athletics Regions, see Rule 300.4.
5. Resident aliens shall be permitted to compete in Regional Championships.

**RULE 3
ASSOCIATION CHAMPIONSHIPS**

1. All members of an Association shall be permitted to compete in that Association's Championships.
2. An athlete who has competed in a Championship of one Association shall not be eligible to compete in the same Championship of any other Association during the same year except as a non-scoring guest at the discretion of the Association meet director or the appropriate Association sports committee.
3. Athletes who are not members of a particular Association may compete as invited guests on a non-scoring basis at the discretion of the meet director or the appropriate Association sports committee.

NOTE: See *USATF Operating Regulations 3, 4, 5, and 7* for other provisions affecting eligibility for Association Championships.

**RULE 4
ELIGIBILITY FOR TEAM CHAMPIONSHIPS**

1. In all USATF Team Championships, whether National, Regional or Association, only teams consisting of duly accredited representatives of a member club shall be eligible to win such team Championship. In Regional Championships, the team Championship may be contested on the basis of Association teams in addition to scoring by club teams, at the option of the Games Committee.
2. In Open and U20 Long Distance Running, Open and U20 Cross Country and Open Track & Field Club competition, an athlete who is a non-resident member of an Association is eligible to compete for a team in that Association only if the athlete:
 - (a) Resides in an adjoining Association within the government-defined Metropolitan Statistical Area (MSA) of a city which is primarily in the neighboring Association as approved by the appropriate sport committee or council or;
 - (b) Has historical membership based upon Association residency (at least three continuous USATF membership years) is eligible to compete for that club. See Rule 341.8 for Masters LDR and Masters Cross Country.
3. For the Track & Field Club Championship:
 - (a) A club within an Association which is not located within any MSA is limited to scoring members who reside -- as defined by federal, state, and local tax protocols -- in the Association's territory.
 - (b) A club within an Association in an MSA which is wholly within the Association's territory is limited to scoring members who reside in the Association's territory.
 - (c) A club within an Association in an MSA which includes territory in one or more other Associations may draw from anywhere within its Association's territory and anywhere within the single MSA within which it is located; provided all

members transfer their membership to the club's Association (see Regulation 4-C for more information on transfers.)

RULE 5 AWARDS

1. Unless otherwise provided in these rules, the following awards shall be given in all Championships:
 - (a) In Team Championships, a trophy shall be awarded to the winning team. Team trophies may be awarded to the second and third teams.
 - (b) Regulation gold and silver Championship medals shall be awarded for first and second places in each individual Championship event. Bronze Championship medals shall be awarded to the third through sixth place finishers, except in the USA Indoor Track and Field Championship, where bronze medals are awarded only to third and fourth place finishers. In Regional and Association Championships gold, silver, and bronze medals may be awarded for first, second, and third places, respectively.

NOTE: *For Youth Athletics, the number of medals awarded in each individual Championship event may be different and shall be determined and documented by the Youth Division.*
 - (c) In events where there is team scoring, regulation gold, silver, and bronze Championship medals shall be awarded to the scoring members of the teams finishing first, second, and third except in Track and Field Championships. In the Men's and Women's Open, U20, and Masters Cross Country Championships, such medals shall be awarded to the declared members of the teams finishing first, second, and third.
 - (d) Unless otherwise determined by the national Sport Committee, patches shall be awarded to the individual winners. Patches may be awarded to the scoring members of the team finishing first except in Track and Field Championships.
 - (e) Except in Masters LDR, whenever an event includes concurrent age-group and overall competition, in which a single performance can qualify for awards in the age group and/or in the overall competition, the entry blank shall specify one of the following:
 - i. That an athlete may win awards in both the overall category and in the athlete's age group, if there are such awards in that athlete's age group, or;
 - ii. That an athlete may win only one award and may, after the race, choose the award for overall competition or for the competition in the athlete's age group, but not both.

If (ii) is specified, competitors in the category not selected by the athlete eligible for more than one award shall be advanced in position so that all possible awards in each category are awarded, if there are sufficient numbers of competitors.
 - (f) In Masters LDR, including cross country, masters shall be allowed to win awards in all categories (e.g., overall, age group and age-graded).
2. Other individual prizes, which shall be specified on the entry blank, may be presented as determined by the Championship sponsor subject to the approval of the appropriate sport committee of USATF. In Masters LDR, including cross country, non-U.S.

citizens, including permanent residents, who are member athletes of USATF, may be awarded separate non-championship medals whenever they would otherwise displace a U.S citizen eligible for awards.

RULE 6 GENERAL

1. USATF Operating Regulation 18 governs bids, bidding procedures, award procedures, selection of dates, rights for broadcast and financial relations of USATF National Championships.
2. All entries for Championships shall be made using the entry format adopted by USATF and may be required online. No entry format for any Championship shall be distributed until it has been submitted to and approved by the Chair(s) of the sport committee(s) involved and the Chief Executive Officer of USATF. The entry format shall include all pertinent information regarding filing dates, late entries, fees, entry appeal and protest procedures, and declaration procedures.
3. When the placing of a competition is used for team selection or to qualify athletes to another competition, the system for selection and/or advancement shall be determined in advance of the event, and published in the entry material/Technical Information.
NOTE: *See Rule 306 for qualification in Junior Olympic competition.*
4. The final date for entries to a National Championship shall be designated by the Chair of the sport committee involved. For track and field, this date shall be at least 14 days (outdoors) or 10 days (indoors) prior to the first competition that is part of the Championship. For the National Track & Field Club Championship, this date shall be at least 14 days prior to the first competition that is part of the Championship. A late entry period, if any, shall be designated by the Chair of the sport committee involved.
5. Entry fees and late fees for all Championships shall be established by each sport committee, subject to the review and approval of USATF, and unless otherwise provided for in its Bylaws, Regulations or these Rules, shall be the property of USATF. Entry fees for the National Track & Field Club Championship and all long distance running events are the property of the event.
6. The officials, and the Games and Seeding Committees who are responsible for the conduct of a Championship, shall be appointed by or subject to the approval of the appropriate sport committee(s).
NOTE: *See USATF Regulation 18-J regarding the selection of officials.*
7. Qualifying standards and procedures may be established for Championships and for qualifying competition for international competition by the sport committee concerned.
NOTE: *See Rule 306 for qualification in Junior Olympic competition.*
8. The rights of defending USA Open individual event National champions shall be governed by the following:
 - (a) Each individual winner of the previous year's USA Open Championship shall be entitled to receive from the sponsoring organization full expenses to enable the athlete to defend his/her title if, in the opinion of the sport committee concerned, the champion is in condition to defend the title.

- (b) Where two or more athletes are co-holders of a Championship, an allotment in an amount equal to the expenses of the co-holder who resides the greatest distance from the city in which the meet or event is being held shall be provided and each co-holder shall receive a pro rate percentage of such allotment, calculated on a mileage basis. Where possible, co-holders should be paid full expenses.
 - (c) For reasons appearing good and sufficient, the Executive Committee of the sport committee concerned, unless otherwise provided by USATF, by a majority vote of those voting, may suspend or abrogate all requirements or provisions for the payment of expenses of any and all champions as provided for herein.
 - (d) If funds are available, all individual event winners of the National Track & Field Club Championship shall receive an equal share of such funds.
 - (e) The sponsoring organization of any Championship, with the approval of the sport committee concerned, may allocate additional funds to other place winners of the previous year's Championship or for noteworthy performers.
9. A Technical Information Center shall be established for the Championships in Rules 10 and 11, and may be used for other competitions. The main function of the Technical Information Center is to ensure smooth communication between the competitors, Games Committee and competition administration regarding technical and other matters relating to the competition.

RULE 7 TEAM SCORING

- 1. For meets that have team scoring, the procedure for scoring, including events and calculation methods, shall be included in the entry material/Technical Information. Prior to the start of the event, the team coach or other representative shall declare the team entries eligible for scoring.
- 2. Regional Championships may be scored on the basis of Association teams instead of club teams at the option of the Games Committee.

TRACK AND FIELD

- 3. The team score shall be the total of all points earned by eligible competitors for a given team. Scoring shall be five (5) points for each first place scored, three (3) points for second, two (2) points for third, and one (1) point for fourth. Events not included on the entry blanks, and events (other than novice events) not open to all USATF member athletes shall not count in the scoring for team point trophies. Relay races shall be scored as any other event. In combined events, the team score shall be the sum of the scores of the top three members of each team. For Masters exemption see Rule 331.2.

LONG DISTANCE RUNNING, CROSS COUNTRY, AND RACE WALKING

- 4. Three methods exist for scoring team Championships: scoring by place, scoring by time and scoring by distance.
- 5. The team Championships in Long Distance Running (including Mountain, Ultra-Marathon and Trail events) and Race Walking shall be scored by time. The team Championships for Open, Masters, U20 and Youth Cross Country shall be scored by place.

6. Scoring by place:
 - (a) The team score shall be the total of the finishing positions of the scoring members. The team with the lowest total points is the team winner.
 - (b) Runners of incomplete teams, team entries not declared eligible for team scoring, and unattached or individual competitors will be eliminated from team scoring. Non-scoring declared members of complete teams shall retain their finishing positions and thereby displace other runners.
 - (c) When separate competitions are conducted simultaneously, each shall be scored independently. Runners on teams not eligible for a given competition will be eliminated from team scoring in that competition.
 - (d) In the event of a tie between two or more individual runners, each shall score the number of points determined by dividing the total of the finish places by the number of runners who have tied.
7. Scoring by time:

The team score shall be the aggregate time of the scoring members. The team with the lowest aggregate time is the team winner.
8. In team Championships scored by time, if the Games Committee determines that scores for the winning teams cannot be determined because of clock failure or other reasons, team Championships shall be determined by scoring by place.
9. Whether scoring by time or place:
 - (a) If a team fails to finish with a complete scoring team, the team members finishing shall be counted as individuals in the race results and shall be eligible to receive individual awards.
 - (b) Ties between two or more teams shall be resolved in favor of the team whose last scoring member finishes nearer to first place.
10. Scoring by distance:

The team score is the sum of the distances covered by the scoring team members.

RULE 8

AUTOMATIC QUALIFICATION

Automatic qualification, as listed in this section, shall not abrogate any entry requirements other than the qualifying requirements for a championship or a team selection held as a championship. Any athlete who attains any of the following shall be afforded automatic qualification into a USA Indoor, Outdoor, Race Walking or Marathon Championship or USA Olympic Team Selection in the same event in which the performance was attained:

1. Track and Field –
 - (a) During the current or four previous calendar years, earned an individual medal in track and field for the USA in an Olympic Games or in a World Athletics World Indoor or Outdoor Championship.
 - (b) Is the most recent champion of the USA Indoor or Outdoor Championship / Olympic Trials.

- (c) Has a World or Olympic Entry Standard that would apply to the current championship team selection.
 - (d) Finish as one of the top three at the preceding year's corresponding national championship (Indoor qualifies for Indoor, Outdoor qualifies for Outdoor).
2. Race Walking - During the current or four previous calendar years:
 - (a) Earned an individual medal in an Olympic Games or in a World Athletics World Championship.
 - (b) Won an individual Championship at a USA Open Track Championship.
 - (c) Won a USA Championship in the Men's 50-Kilometer Walk.
 - (d) Earned a USA Olympic Team Selection.
 3. Marathon - During the current or four previous calendar years:
 - (a) Earned an individual medal in an Olympic Games or in a World Athletics World Championship.
 - (b) Won an individual USA Marathon Championship.
 - (c) Earned a USA Olympic Team Selection.

RULE 9
NON-CHAMPIONSHIP COMPETITIONS

1. So far as possible, the rules for the Championships shall apply to all other competitions conducted or sanctioned by USATF or any of its Associations. In competitions other than National Championships, events may be held in a different format to that provided under the USATF Rules of Competition, but broader Rules, giving more rights to the athletes, cannot be applied. These formats shall be decided by the respective bodies having the control over the competition.
2. In the case of mass participation events held outside the stadium, these rules should normally only be applied in full to those competitors, if any, who are designated as taking part in the elite or other defined section of the races such as age group categories for which there are placings for awards or prizes. Race organizers should outline, in the information provided to other competitors, which other rules will apply to their participation, particularly those pertaining to their safety.
3. Unless otherwise provided in these rules, age limitations or divisions for Championship competition apply to open events or meets sanctioned or conducted by USATF. In Long Distance Running non-championship events, age divisions may be determined by the Association sport committee or the sponsoring organization.
4. Points for track and field meets shall be scored in accordance with the appropriate provisions of Rule 13, except that events not included on the entry blanks, and events (other than novice events) not open to all USATF member athletes shall not count in the scoring for team point trophies. Relay races shall be scored as any other event.
5. When a prize or trophy is awarded for individual high scoring in any meet, points shall be scored in the same manner as points would be scored for the team

Championships or point trophy in that meet, except that points scored for relay races shall not be counted. In case of a tie, the trophy or prize shall be awarded to the competitor winning the most first places.

SECTION II
MEN'S AND WOMEN'S TRACK AND FIELD CHAMPIONSHIPS

RULE 10
USA OUTDOOR TRACK AND FIELD CHAMPIONSHIPS

1. The Men's and Women's Track and Field Committees shall annually conduct the USA Outdoor Open and U20 Track and Field Championships. The Men's and Women's Championships may be conducted jointly, or each Championship may be conducted separately. The Chairs of the Track and Field Committees and/or their appointed representative(s) shall be Referee(s) of the Championships. It is recommended that such Referee(s) be certified officials at the National or Master level.
 - (a) The Open Championships, at the discretion of the National Track and Field Committees, shall be held as a two-, three- or four-day meet in accordance with a time schedule of events determined by the National Track and Field Committees.
 - (b) The U20 Championships may be held separately from the Open Championships.
NOTE: *See Rule 12 for The National Track & Field Club Championships. See Rule 13 for Regional and Association Championships.*
2. (a) Following are the standard events for the USA Open and U20 Outdoor Track and Field Championships:

Men's Events

100 Meters	110 Meter Hurdles
200 Meters	400 Meter Hurdles
400 Meters	High Jump
800 Meters	Pole Vault
1500 Meters	Long Jump
3000 Meters (U20)	Triple Jump
3000 Meter Steeplechase	Shot Put (7.26kg) (U20 - 6kg)
5000 Meters	Discus Throw (2kg) (U20 - 1.75kg)
10,000 Meters (Open)	Hammer Throw (7.26kg) (U20 - 6kg)
10,000 Meter Walk (U20)	Javelin Throw (800g)
20,000 Meter Walk (Open)	Decathlon

Women's Events

100 Meters	100 Meter Hurdles
200 Meters	400 Meter Hurdles
400 Meters	High Jump
800 Meters	Pole Vault
1500 Meters	Long Jump
3000 Meters (U20)	Triple Jump
3000 Meter Steeplechase	Shot Put (4kg)
5000 Meters	Discus Throw (1kg)
10,000 Meters (Open)	Hammer Throw (4kg)
10,000 Meter Walk (U20)	Javelin Throw (600g)
20,000 Meter Walk (Open)	Heptathlon

- (b) Open USA Race Walking Championship shall, where practical, start and/or finish on the track.
3. In the USA Track and Field Championships:
- (a) All entered contestants shall have met the qualifying requirements / meet entry guidelines adopted by the respective sport committee, or by the properly authorized subcommittee thereof or shall be approved by a special appeal subcommittee appointed by the Chairs of the respective sport committees;
 - (b) Qualifying requirements / entry guidelines shall be published in the entry material/Technical Information;
 - (c) In appointing the appeal subcommittee every effort shall be made to include representation from athlete, coach, and sport committees. Petitions to the appeal subcommittee shall be presented in writing, including electronic communication, without the possibility of further appeal beyond the appeal subcommittee. Petitions and decisions shall be posted at the subcommittee work site. The addition of an athlete by petition shall not prevent an otherwise qualified athlete from participation.
4. (a) The Meet Director, Games Committee, and/or sponsoring organization of the USA Track and Field Championships shall:
- i. Provide and make available all material specified in Rule 6.2 at least 60 days prior to the competition via a posting on the USATF website;
 - ii. Provide via a posting on the USATF website, by 9 p.m. two days prior to competition, a list of entrants in each event, arranged in order of their performances, if any, used for entry into the competition. If there are any corrections or appeals necessary to the posted entries or performances, these shall be submitted in writing, which includes electronic communication, to the appropriate Track and Field Committee Chair, or the Chair's appointed representative, by 1 p.m. on the day prior to the start of the Championships;
 - iii. Notify the entrant or his/her representative of any irregularity in an application, that would prevent the individual from being considered for selection to compete in the Championship, at least three days before the meet. The posted status of an application on the USTAF website may serve as this notification;
 - iv. Together with the National Track and Field Committee Chair or the Chair's appointed representative(s), finalize all events, form the heats for competition, and publish them at least 24 hours prior to the time of competition for each event via a posting on the USATF website.
- (b) Ensure the accurate preparation, posting and publication of the Call Room Schedule in accordance with Rule 136.1.
- (c) The coaches, athlete representatives or individual athletes in the USA Track and Field Championships shall:
- i. Properly submit entries on forms provided for that purpose. All entries shall be submitted in accordance with the procedure stated on the entry form or in the entry material/Technical Information.

- ii. Submit final declarations for or by each athlete for each entered event as stated in the entry material/Technical Information. Declarations by officially designated website, or other method authorized in the entry material/Technical Information, shall be received no later than 8 p.m. two days prior to the start of the Indoor Championships and no later than 12 noon two days prior to the start of the Outdoor Championships.
- iii. Submit to the Games Committee no later than the day prior to the first day of the Championship competition, evidence of membership in USATF. Such evidence may consist of the athlete's membership card (or copies thereof), or, when the foregoing is unobtainable, of a written statement signed by the Chair of the Member Services Committee or the Secretary of an Association, on the letterhead or appropriate form of the Association, indicating that the named athletes were athlete members of a registered club.

NOTE: *Competitors who have not complied with these provisions will not be entered in the Championships unless they appeal in person to the National Track and Field Committee Chair or the Chair's appointed representative. Petitions for late declarations shall be based on corroborated evidence that a declaration was made during the proper declaration period. The National Track and Field Committees shall establish a procedure to process appeals.*

- 5. See Rule 5 for awards.

RULE 11 USA INDOOR TRACK AND FIELD CHAMPIONSHIPS

- 1. The Men's and Women's Track and Field Committees shall annually conduct the USA Open Indoor Track and Field Championships. The Men's and Women's Championships may be conducted jointly, or each Championship may be conducted separately. The Chairs of the Track and Field Committees and/or their appointed representative(s) shall be Referee(s) of the Championships. It is recommended that such Referee(s) be certified officials at the National or Master level.
- 2. (a) Following are the standard Championship events for the USA Indoor Track and Field Championships (Open or U20).

Men's Events

60 Meter Dash	High Jump
200 Meter Dash	Pole Vault
400 Meter Dash	Long Jump
800 Meter Run	Triple Jump
1500 Meter or 1 Mile Run*	Shot Put (7.26 kg) (U20 - 6 kg)
3000 Meter Run	Weight Throw (35 lb.)
3000 Meter Walk	Heptathlon
60 Meter Hurdles	
4x400 Meters Relay	
4x800 Meters Relay	
Distance Medley Relay (1200-400-800-1600)	

Women's Events

60 Meter Dash	High Jump
200 Meter Dash	Pole Vault

400 Meter Dash	Long Jump
800 Meter Run	Triple Jump
1500 Meter or 1 Mile Run*	Shot Put (4 kg)
3000 Meter Run	Weight Throw (20 lb.)
3000 Meter Walk	Pentathlon
60 Meter Hurdles	
4x400 Meters Relay	
Distance Medley Relay (1200-400-800-1600)	

**In years of World Athletics World Indoor Championships, if the qualifying standards for the World Athletics meet do not include a standard for the mile, the 1500 Meters shall be run.*

- (b) The order of events shall be determined by the National Track and Field Committees or their representatives.
 - (c) The 200m event may be conducted at the discretion of the appropriate Track and Field Committee, either as a Championship or non-Championship event.
 - (d) No more than two teams may be entered by any club in any relay race.
 - (e) The relays listed may be conducted at the discretion of the appropriate Track and Field Committee, either as Championship or non-Championship events.
3. (a) Each competitor in all track events, including each relay team, shall, in person or through an authorized representative, report to the Clerk of Course one hour before the start of the first listed round of the event and confirm their declaration as to whether he/she/they will or will not compete in the event. Directly thereafter, the Clerk of Course shall turn over the actual list of starters to the Chair of the Track and Field Committee who, with the Referee and such other persons as he or she may appoint, will determine whether the number of rounds in the event, or the number of heats in each round or the seeding of athletes in particular heats should remain as previously announced or should instead be changed.
- (b) Where there are insufficient entrants who have met the qualifying standards and who have declared that they will compete, to make a final of an event competitive, the Games Committee or its representatives, prior to the day of the Championships, may approve for that final a limited number of additional entries from those who have entered the event prior to the closing date for entries, but who have not met the qualifying standards for that event, provided that such additional entries be approved in the order of best qualifying performance. The Games Committee shall exercise reasonable efforts to notify those entrants of the opportunity to compete.
 - (c) The provisions of Rules 10.3 and 10.4 pertaining to the conduct of the Outdoor Championships shall be applicable to the Indoor Championships unless otherwise provided in this Rule.
4. See Rule 5 for awards.

RULE 12
NATIONAL TRACK & FIELD CLUB CHAMPIONSHIPS

1. The Associations Committee, through its Club Council, and with assistance and representation from the Men's and Women's Track & Field Committees and the Race Walking Committee, shall annually conduct the National Track & Field Club Championships. This will be a combined men's and women's championship. The Club Council chair, with the consent of the chair of the Associations Committee shall appoint the Games Committee, Referee(s), and chief officials, who shall be certified officials at the National or Master level.
2. Regional club championships may be held in each region and used for qualification into the national meet.
3. All participants shall be a member of a USATF member club. Unattached athletes and non-resident aliens may not compete.
4. Rule 10 shall apply to the National Track & Field Club Championships except that:
 - (a) The meet shall be a two-day meet;
 - (b) The time schedule shall be determined by the Games Committee;
 - (c) The following relays are included as standard events:
 - 4x100 Meters Relay
 - 4x400 Meters Relay
 - 4x800 Meters Relay
 - Sprint Medley Relay (200-200-400-800)
 - Distance Medley Relay (1200-400-800-1600);
 - (d) The Race Walk distance shall be set in consultation with the Race Walking chair.
5. Qualifying - In the Club Track & Field Championships, all entered contestants shall have met the qualifying requirements adopted by the Club Council or by the properly authorized subcommittee thereof and listed in the published entry material/Technical Information, or shall be the single entrant in an event for that club.
6. Conduct of the Championships - The Council Chair, Games Committee Chair, and Meet Director shall finalize all events, make modifications to the time schedule, formulate the heats, advancement, and timed-final parameters, and publish them at least forty-eight (48) hours in advance of the first scheduled competition on the USATF website.
7. Scoring and awards - Team scoring shall be according to the provisions of Rule 7. Awards shall generally be governed by Rule 5. A most valuable trophy shall be presented to the male and female athletes who score the most points for their team, including one quarter of relay points. A best performance trophy shall be awarded to the male and female athlete whose individual performance scores highest on the approved World Athletics point tables. A suitable recognition may also be made of the Association whose athletes score the greatest number of points in the championships.

RULE 13
OTHER CHAMPIONSHIPS

1. The provisions of Rule 10.3 and Rule 10.4 pertaining to the conduct of the Outdoor Championships, shall be applicable to the Championships listed in this Rule, unless otherwise provided in this Rule. In addition to the USA Open and U20 Outdoor, the USA Indoor Championships, and the National Track & Field Club Championships, as above, the following Championships may be conducted at the discretion of the National Track and Field Committees:

Men

- (a) USA U20 Indoor Track and Field Championships.
- (b) Club Relay Championships
 - 400 Meters Relay (4x100)
 - 800 Meters Relay (4x200)
 - 1600 Meters Relay (4x400)
 - 3200 Meters Relay (4x800)
 - 6000 Meters Relay (4x1500)
 - 440 Meters Shuttle High Hurdles Relay (4x110)
 - 1600 Meters Sprint Medley Relay (400-200-200-800)
 - 4000 Meters Distance Medley Relay (1200-400-800-1600)
 - (All relays may be run in the equivalent yard distances.)
- (c) Decathlon (see Rule 200)
- (d) Pentathlon (see Rule 200)
- (e) Indoor Pentathlon (see Rule 200)
- (f) Indoor Heptathlon (see Rule 200)
- (g) 56 lb. Weight Throw (see Rule 195). This event shall be held independently of the USA Track and Field Championships.

Women

- (a) Heptathlon (see Rule 200)
 - (b) Decathlon (see Rule 200)
 - (c) Indoor Pentathlon (see Rule 200)
 - (d) Club Relay Championships (all events listed under Men (b) above).
2. Regional and Association, Open and U20 Outdoor Track and Field Championships may be held. Rule 10 shall apply to such Championships except:
- (a) The Mile may be conducted instead of the 1500 Meters, at the discretion of the appropriate sports committee.
 - (b) A 5000 or 10,000 Meter Race Walk may be conducted instead of the 20,000 Meter Race Walk.
 - (c) See Rule 13.5 for scoring.

3. Regional and Association Open and U20 Indoor Track and Field Championships may be held. Rule 11 shall apply to all such Championships except:
 - (a) In Association Championships, the Men's Race Walk may be either 3000 Meters or 5000 Meters.
 - (b) See Rule 13.5 for scoring.
4. The declaration procedures for Championships in this Rule shall be established by the Games Committee of each Championship and made known through the inclusion of such procedures in the entry material/Technical Information for the Championship. At the time of the declaration of entries, the declarer shall indicate whether or not relay teams entered are to compete, but designation of the make-up of a relay from the athletes listed for the relay team entered need not be made until the designated time before the start of the first round of the event as determined by the Games Committee or by these rules. The entry form for the Combined Events at any National Championship shall include provision to enter best individual performances for each event of the Combined Event during the defined qualification period.

POINT SCORE - TROPHIES

5.
 - (a) There may be a team Championship, scoring or point trophies in all events listed in this Rule and for other meets sanctioned by any Association. Regional Championships may be scored on the basis of Association teams instead of club teams at the option of the Games Committee. Scoring in all Championships in this Rule shall be five (5) points for each first place scored, three (3) points for second, two (2) points for third, and one (1) point for fourth.
 - (b) The provisions of Rule 10.5(b) and (c) pertaining to ties and trophies shall be applicable to all events listed in this Rule.
 - (c) In combined events, the team score shall be the sum of the scores of the top three members of each team.
6. See Rule 5 for awards.

RULE 14 TRANSFERRING MEMBERSHIP PRIOR TO CHAMPIONSHIP

In Men's and Women's Track and Field, an athlete who is an athlete member of one club, other than an educational institution, at the date of closing of entries for Championships under the jurisdiction of the track and field sport committees, may not change membership to another club prior to the Championships or be eligible to represent or score points for the club to which he/she seeks to change membership. If the athlete does not desire to compete for the original organization, he or she may compete unattached, representing no club. Notwithstanding the above, an athlete may transfer from an educational institution to a club in accordance with USATF Operating Regulation 4.

**SECTION III
CROSS COUNTRY & LONG DISTANCE RUNNING CHAMPIONSHIPS**

**RULE 15
MEN'S AND WOMEN'S CROSS COUNTRY CHAMPIONSHIPS**

1. There shall be National Cross Country Championships conducted by the Cross Country Council.
2. The National Championship shall include individual and club team competition in the Open, Masters and U20 divisions as well as being national team selections if applicable.
3. Additional championship or team selection events may be conducted if the international calendar dictates. Runners may compete in any championship as individuals. The Cross Country Council may add additional Masters Cross Country Championships to the national schedule.
4. Eligibility for the National Championships shall be as stated in Rule 1.1(a). Association Championships are open to all athlete members of USATF. Age limitations are as stated in Rule 141.

5. The distances contested at National Team Selection event Championships shall be as close as feasible to the distances contested in the corresponding World Athletics World Cross Country Championships. When there is no World Championship in that year, the distances shall be 10 km for open men and open women, 8 km for U20 men, and 6 km for U20 women. The measured distances should be printed in the program and the results.

6. The number of entries for a team shall be unlimited. In National Championships, including club team competition, a maximum of eight entries shall be declared and the first five declared members of each team shall count in that team's score. The following chart shows the race distances (as close as is feasible) and team scoring members. The distances shown for the Winter Championships are those currently used by World Athletics.

Championship	Men's Dist.	Women's Dist.	Declared	Scorers
Open	10 km	10 km	8	5
U20	8 km	6 km	6	4

7. See Rule 7 for scoring for the National Championships. See Rule 341.1 for Masters' distances, declaration, and scoring. See Rule 5 for awards.

8. Team competitions may be conducted in all races for association Clubs and additionally in the open races including teams representing the branches of the Armed Services.

9. If a club enters more than one team, each team should be clearly identified.

RULE 16
LONG DISTANCE RUNNING CHAMPIONSHIPS - MEN

1. The Men's Long Distance Running (LDR) Committee may conduct USA Open and U20 Championships in the events shown in the following table. In addition to these championships, the Men's LDR Committee may, on an annual basis, award National Championships at other distances under their jurisdiction including the Road Mile.

TABLE OF EVENTS				
Event	Open	U20	Declared	Scorers
Road				
5 km	X	X	8	5
8 km	X	X	8	5
10 km	X	X	8	5
12 km	X	X	8	5
15 km	X	X	8	5
20 km	X	X	8	5
Half Marathon	X	X	8	5
25 km	X		8	5
30 km	X		5	3
Marathon	X		5	3
Marathon Relay	X	X	Unlimited	Team
Track				
1 hour*	X	X	5	3

* May be postal event

2. Regional Championships may be conducted at the distances listed in the same table. (See Rule 2 for regions). Regional Championships shall be awarded by a vote of Men's LDR committee representatives from the Associations in that region. Eligibility and awards are the same as for National Championships. Associations are encouraged to conduct Championships at the distances listed in the table.
3. Eligibility for the Championships shall be as stated in Rule 1.1(a). Age limitations are as stated in Rule 141.
4. The maximum number of entries per team shall be unlimited. The number of entries to be declared, and the scoring for a team for National, Regional, and Association Championships, unless otherwise provided in these rules, is set forth in the table below.
5. The Men's LDR Committee may contest additional team championships, with a separate set of awards.
6. National and Regional Marathon Championships may be conducted using time limits which shall be stated in the bid application to the Men's LDR Committee and on all entry forms or in entry material/Technical Information.
7. In the marathon road relay, teams shall consist of six runners with legs in the following order: 10km, 5km, 10km, 5km, 5km, and 7.195km, or five runners with legs in the following order: 10km, 5km, 10km, 5km, and 12.195km.
8. The courses of all National, Regional, and Association Road Championships shall meet certification requirements stated in Rule 240.

- See Rule 5 for awards. See Rule 7 for scoring.

**RULE 20
LONG DISTANCE RUNNING CHAMPIONSHIPS - WOMEN**

- The events listed below may be conducted by the Women's Long Distance Running (LDR) Committee as USA Championships for women. In addition to these Championships, the Women's LDR Committee may, on an annual basis, award National Championships at other distances under their jurisdiction.

CHAMPIONSHIP DISTANCES

Track or Road	Track	Road	
15 km	Mile	5 km	Half-Marathon
20 km	1 hour*	8 km	Marathon
25 km	2 hour*	10 km	Marathon Relay
30 km	*postal event	12 km	

- Regional Championships in the foregoing events may be conducted after being awarded by the Regional Chair of the Women's LDR Committee. Association Championships should be conducted by each Association in the foregoing events.
- The maximum number of entries for a team shall be five women and only the first three members of each team to finish shall count in the team scoring. In Association championships, the maximum number of entries for a team, and the number of members of each team for scoring may be determined by the Games Committee and shall be stated in the entry material/Technical Information.
- In the marathon road relay, teams shall consist of six runners with legs in the following order:10km, 5km, 10km, 5km, 5km, and 7.195km, or five runners with legs in the following order:10km, 5km, 10km, 5km, and 12.195km.
- In addition to the USA, Regional and Association Championships set forth above, the Age Group Championships for ages 30-34 and 35-39 may be conducted as part of the Women's LDR Championships.
- There may be a qualifying standard for entry into a National LDR Championship.
- Eligibility for the Championships shall be as stated in Rule 1.1(a). Age limitations are as stated in Rule 141.
- The courses of all National, Regional, and Association Road Championships shall meet the certification requirements stated in Rule 240.
- See Rule 5 for awards. See Rule 7 for scoring.

RULE 21
MOUNTAIN, ULTRAMARATHON AND TRAIL CHAMPIONSHIPS

1. The Mountain/Ultra/Trail Running Council may annually conduct U20 and/or Open and/or Masters Mountain and/or Ultra-Marathon and/or Trail Running Championships at such distances as it deems appropriate. These Championships shall be conducted using the rules for each type of race. See Rules 240 – 256.
2. Regional Championships may be conducted after being awarded by the Mountain/Ultra/Trail Running Council and Associations may conduct Association Championships
3. The courses of all National, Regional, and Association Ultra-Marathon Road Championships must meet the certification requirements stated in Rule 240.
4. Teams
 - (a) The maximum number of entries per team shall be unlimited.
 - (b) Team championships shall be conducted in 10 year age divisions for men and women as follows: U20, open, 40+, 50+ 60+, etc. Team runners are scored on all teams for which they are eligible, thus a 25 year old is scored on the Open team only while a 50 year old may be scored on the Open, 40+, and 50+ teams.
 - (c) The top 3 runners for each team shall be scored, except the top 5 shall score for the Open Men at distances under (and not including) 30km.
5. Eligibility for the Championships shall be as stated in Rule 1.1(a). Age limitations are as stated in Rule 141.
6. See Rule 7 for scoring.

**SECTION IV
RACE WALKING CHAMPIONSHIPS**

**RULE 25
CHAMPIONSHIP EVENTS - MEN AND WOMEN**

1. Upon receipt of acceptable bids, the following USA Open and U20 Championships may be conducted by the Race Walking Committee (the events may be conducted as Association or Regional Championships following the rules for the USA Championships):

- (a) Outdoor Championships:

		Men			
		Open			U20
5 km	30 km	100 Miles	5 km		1 hour
10 km	35 km	1 hour	10 km		
15 km	40 km	Half-Marathon	15 km		
20 km	50 km	Marathon	20 km		
	100 km				

		Women			
		Open			U20
5 km	30 km	100 Miles	5 km		1 hour
10 km	35 km	1 hour	10 km		
15 km	40 km	Half-Marathon	15 km		
20 km	50 km	Marathon	20 km		
	100 km				

Mixed Gender

Open Marathon Mixed Relay

NOTE: *Outdoor Championships events stated in metric distances may be held on a track or road course or both in any given year for each distance.*

- (b) Indoor Championships:
 Men -- One Mile; 3000 Meters (held with Track and Field Championship); 5000 Meters. U20 Men – 3000; 5000 Meters.

 Women -- One Mile; 3000 Meters (held with Track and Field Championship); 5000 Meters. U20 Women – 3000; 5000 Meters.
2. Teams and Reserves:
 (a) For other than National Championships, each team may enter an unlimited number of athletes. A maximum of five and minimum of three athletes form a team for National Championships. Team members must be declared prior to the competition. The first three finishers of each team shall score. A club may enter more than one team, but all members of each scoring team must be appropriately declared prior to the competition.

 (b) Members ineligible at the declaration of the team for team competition may race as individual entries; individual entries will be accepted. Members of depleted teams that are unable to field the necessary scoring number may race as individual entries.
3. The courses for all National, Regional, and Association Road Championships must meet certification requirements stated in Rule 240.
4. See Rule 5 for awards. See Rule 7 for scoring.

SECTION V
OLYMPIC TEAM SELECTION

RULE 27
U.S. OLYMPIC SELECTION COMPETITION

1. The provisions of Rule 6, Rule 8, Rule 10.3 and Rule 10.4 pertaining to qualifying requirements, entry/Technical Information, entry procedure, forms, fees, entry appeals, competition procedures and competition regulations of the USA Outdoor Championships shall be applicable to the USA Olympic Selection Competition unless otherwise provided in this Rule or in the entry/Technical Information.
2. The personnel conducting the U.S. Olympic Selection Competition shall be selected in the following manner:
 - (a) Members of the Jury of Appeal shall be nominated by the applicable sport committee(s).
 - (b) Referees shall be nominated by the joint subcommittee of the applicable sport committee(s) and, for events held entirely within the stadium, the National Officials Committee.
 - (c) The provisions of Rule 6.5 shall apply to the USA Olympic Selection Competition.
 - (d) Track and Field competition officials shall be selected as described in Regulation 18-J.
 - (e) All Marathon officials shall be selected by the appropriate Long Distance Running Committee.

ARTICLE II
MEDICAL SERVICES AND DOPING CONTROL

RULE 32
DOPING

1. Under the Rules of World Athletics and the Operating Regulations of USATF, doping is strictly forbidden. The governing provisions are those of World Athletics, their Athletics Integrity Unit, and USATF Regulation 20. The list of prohibited substances and testing methods is included in the World Anti-Doping Code and List of Prohibited Substances and Methods. That list may be amended from time to time. <https://www.wada-ama.org/en/resources/world-anti-doping-program>
2. Individuals who have committed doping offenses may be declared ineligible and may lose medals won and records set subsequent to the offense. If the offense is based on in-competition testing, prizes or appearance money earned at that competition and subsequent competitions are subject to forfeiture.
3. USATF participates in out-of-competition and in-competition doping control programs conducted by various drug testing authorities. One program is conducted by the United States Anti-Doping Agency (USADA) on behalf of the United States Olympic & Paralympic Committee (USOPC). Another is conducted by IDTM on behalf of World Athletics. On occasion, USADA conducts testing on behalf of World Athletics. World Athletics has also contracted with the World Anti-Doping Agency (WADA) to conduct testing of track and field athletes on its behalf. Therefore, a USATF athlete may be drug tested by USADA, IDTM, or WADA. The relevant protocols are set forth in the 2026 USATF Governance Handbook

RULE 49
ATHLETE FITNESS AND WAIVER

1. Athletes are responsible for their own physical health and for their own medical supervision.
2. By entering a USATF sanctioned competition, an athlete specifically releases USATF (and its perspective members, directors, officers, employees, volunteers, contractors or agents) from any liability to the extent permitted by law for any loss, injury or damage that may be suffered in relation to or as a result of participation in such competition.

**ARTICLE III
OFFICIALS**

**RULE 110
MEET PERSONNEL**

1. There shall be as many officials at a meet as are necessary for its orderly and efficient operation, and compliance with these rules. The size of the meet and the level of competition both play a role in determining the number of officials to be used at an event. In some cases, the number of officials conducting an event may be reduced significantly.
2. Officials assigned as competition officials should be those certified by the National Officials Committee of USATF.
NOTE: *The training and certifying of officials for athletics is supervised by the National Officials Committee and by the Officials Committee of each Association of USATF as authorized by USATF Regulation 16-I. Information may be obtained by contacting the Association Officials Chair or visiting the NOC website <https://www.usatf.org/programs/officials/certification>.*
3. Except for Competition Officials appointed in accordance with USATF Regulation 18-J, the Games Committee shall determine the number and appointment of Competition Officials including when and how the appointments are made.
4. The following personnel are important for the good conduct of a competition and recommended as a minimum, including Chief Judges where applicable, for the USATF National Championships specified in Rule 10 and Rule 11:

Event Management Personnel

Meet Director
Games Committee
Competition Director
Assistant Competition Directors, as needed

Management Officials	Minimum Indoor	Minimum Outdoor
Technical Manager	1	1
Jury of Appeal	3	3
Referee – Clerking	1	1
Referee - Running	1	1
Referee - Start	1	1
Referee - Field	1	1
Referee - Combined	1	1
Referee – Race Walking	1	1
Referee – Video	1	1
Photo Finish Operator	1	1
Competition Secretary	1	1
Start Coordinator	1	1

Competition Officials	Minimum Indoor	Minimum Outdoor
Event Presentation Manager	1	1
Clerks of Course	4	6
Finish Line Judges*	9	12
Finish Line Coordinator	1	1

Field Judges		
Pole Vault, High Jump	4	4
Long Jump, Triple Jump	4	4
Shot Put, Weight	6	6
Discus, Javelin, Hammer	-	6
Electronic Measurement Judge	1	1
Umpires	8	12
Timers*	12	12
Photo Finish Judges	2	2
Transponder Timing Judges	2	2
Starter	1	1
Recall Starter	1	2
Starter's Assistant	1	2
Lap Scorers	2	2
Marshals	4	5
Wind Gauge Operator	-	2
Inspector of Implements	1	2
Walk Judges	5	5
Race Walking Officials	2	2
Recorder of Records	1	1

*Where adequate automatic Photo Finish devices are available, this number should be reduced substantially. See Rules 126.3 and 128.4.

Support Personnel (as needed)

Announcer	Doctor
Surveyor	Performance Board Operators
Press Steward	Awards Custodian

- The following officials and support personnel are recommended for the conduct of cross country and road events:

Referee	Course Umpires
Starter	Course Recorders
Clerk of Course	Chute Umpires
Chief Finish Judge	Chute Controller
Finish Judges	Competition Secretaries
Judges' Recorder	Marshals
Timers	Doctors
Timers' Recorder	Press Steward
Jury of Appeal	Lap Counters

- Referees and Chief Judges should wear a distinctive armband or badge.
- It is recommended that there be 6 to 9 Race Walking Judges, plus a sufficient number of Race Walking Officials.
- Where feasible, no official should act in a dual capacity within the decision-making chain of officials of an event. A coach should not serve as an official or Referee for any single event(s) in which an athlete whom he/she coaches competes. Whenever possible, officials shall not judge an event in which an immediate family member or significant other is entered.

9. No track team or club team manager or coach should act as an official at a Championship, international selection competition, or international meet held under World Athletics Rule 1.1(a) through (d) for any single event(s) in which an athlete whom he/she coaches competes.

**RULE 111
GAMES COMMITTEE**

1. In Championship meets, the Games Committee shall be appointed by the sport committee or committees of USATF.
2. In non-championship meets, this Committee may be appointed by the entity holding the meet.
3. This Committee shall be responsible for the correct conduct of the meet. It shall provide a place properly laid out and measured to conform to all the requirements of these rules, the appropriate sections of the World Athletics Track and Field Facilities Manual and, shall also furnish all implements and equipment necessary for the satisfactory competition of the events scheduled in the official program, and shall have jurisdiction of all matters either before or during the competition not assigned by these rules to the Referee or other officials. They shall consult with the Competition Director and Referee as appropriate and may delegate operational responsibility for some or all of these areas to the Competition Director.
4. In non-championship meets, a meet director or meet manager, or both, may exclusively, or with the entity holding the meet, carry out any of the above-described functions.
5. The Competition Director, or an Assistant, shall check that all officials have reported for duty, provide briefings, appoint substitutes when necessary, and shall have authority to remove from duty any official for cause. In cooperation with the appointed Marshall, he/she shall arrange that only authorized persons are allowed in the competition area.

**RULE 118
PHOTO FINISH OPERATOR**

The Photo Finish Operators have the responsibility for assembling, positioning, connecting, and properly operating all components used in the capture of images used by the Photo Finish Judges. At the beginning of each session, the Chief Photo Finish Operator shall provide the technical expertise to the Chief Photo Finish Judge to ensure that the official and backup Photo Finish equipment (i) is started automatically by the Starter's starting device and (ii) is correctly aligned with the finish line. See Rules 128.6 and 165.10(a).

**RULE 119
JURY OF APPEAL**

1. A Jury of Appeal composed of 3 or 5 persons, preferably certified officials, may be established by the Games Committees to consider appeals from decisions of or referrals from the Referee as to matters that develop during the conduct of the event. In instances where there is an appeal relating to Rule Race Walking, at least one member of the Jury should be a certified Race Walk judge as defined in Rule 230.1(e).

2. One of its members shall be the Chair. For Championships held under Rules 10 and 11, and when it is considered appropriate, a Secretary, who may be a nonmember of the Jury, shall be appointed. One or more alternates should also be named. Referees shall not serve as members of the Jury of Appeal. In no case shall any management personnel or competition official serve on a Jury of Appeal in considering any appeal where such person has previously performed an official function in respect of the matter being appealed. No member of the Jury of Appeal shall be present during any deliberations concerning an appeal that affects, directly or indirectly, an athlete affiliated with that member.
3. For National, Regional, and Association Long Distance Running and Cross Country Championship events and events sanctioned under Regulation 23-A or 23-B, a Jury of Appeal shall be appointed. For all non-championship long distance running and cross country events, a Jury of Appeal should be appointed, where feasible. For National and Regional Long Distance Running and Cross Country Championship events at least one member of the Jury of Appeal, as selected under Regulation 18, shall be certified as a competition official at the National or Master level.
4. (a) The Jury of Appeal shall, as its sole function in matters resulting from a Referee decision, determine if the decision of the Referee or the Chief Race Walking Judge is based upon adequate evidence and within the scope of the authority given to such person. If such determination is in doubt, the Jury of Appeal shall consult with all relevant persons, including the relevant Referee, and may consider other available evidence, including any available video evidence. The decision of the Referee or the Chief Race Walking Judge shall be upheld unless shown to be clearly erroneous.

(b) For matters not the result of a Referee decision, the deliberations and actions of the Jury of Appeal shall be governed by Rule 125.

(c) The decision of the Jury of Appeal shall be final. There shall be no further right to appeal. The Jury of Appeal may, however, reconsider decisions if new conclusive evidence is presented. In Youth Athletics, only video designated as official by the Games Committee before the competition may be used.

NOTE: *For appeal procedures, see Rule 146.10.*

RULE 123 TECHNICAL MANAGER

The Technical Manager shall be responsible for:

1. Ensuring that the track, runways, circles, arcs, sectors, landing areas for field events and all equipment are in accordance with the Rules and shall verify the calibration of electronic measuring equipment. Certification of such shall be made to the appropriate Referee prior to the commencement of the competition.
2. Ensuring that the placement and removal of equipment according to the technical organizational plan for the competition as approved by the Games Committee.
3. Ensuring the technical presentation of the competition areas is in accordance with such plan.
4. Ensuring that the necessary certification under Rule 148.1 exists or has been received before the competition.

RULE 124
EVENT PRESENTATION MANAGER

1. The Event Presentation Manager shall plan, in conjunction with the Competition Director, the event presentation arrangements for a competition in cooperation with the Games Committee as and where applicable.
2. The Event Presentation Manager shall ensure that the plan is accomplished, resolving any relevant problems together with the Competition Director and the relevant members of the Games Committee.
3. The Event Presentation Manager shall direct the interaction between the members of the event presentation team (announcers, awards, broadcast), using a communication system to be in contact with each of them.
4. The Announcer shall ensure that through announcements and the available technology the public is informed of information concerning the competitors taking part in each event, including the start lists, intermediate and final results. The official results (placings, times, heights, distances and points) of each event should be conveyed at the earliest possible moment after receipt of the information.
5. At competitions held under Rule 10 or Rule 11, the Announcers shall be approved by USATF.

RULE 125
REFEREE

1. One or more Referees, as appropriate, shall be appointed for the clerking area, for running events (including starts and events outside the stadium), for field events, for Combined Events, for video review and for Race Walking. The Video Referee shall operate from a Video Control Room. The Video Referee shall be in communications with and should consult with appropriate other Referees. The Running Referee shall have no jurisdiction over matters within the responsibilities of the Chief Judge of Race Walking events. See rules 230 and 232.
2. The Referee shall ensure full conformity with the rules and applicable USATF competition regulations and shall decide, where appropriate or necessary, in conjunction with the Games Committee, upon any matters which arise during the meet, including any matter arising at competitor check-in, within the warm-up area and after the actual competition, including awards, and for which provision has not been made in these rules or any applicable competition regulation. The Referee for track events and for events outside the stadium shall have jurisdiction to decide placing in a race only when the Chief Finish Judge is unable to arrive at a decision. The Referee shall not act as a Judge or Umpire but may take any action or decision according to the Rules based on their own observation and may overrule the decision of a Judge.
3. A Referee, when appointed to specifically oversee the starts, is designated the Start Referee. The Start Referee, or the relevant Running Referee if one is not appointed, has the authority to make a final decision on any facts related to the start of a race where there is disagreement with a decision of the Starter. This authority is not granted in cases when the start involves the 'commencement of a start' coupled with an illegal reaction time indicated by a start information system, unless, for any reason, the

Referee determines that the information provided by the system is obviously inaccurate or not fully considered in the determination of the rule violation.

4. The appropriate Referee, for running or field events, shall ensure the positioning of the wind gauge per Rule 163.11.
5. The decision of the Referee in all matters shall be final and without further right to appeal except in those meets or events for which a Jury of Appeal has been established for that special purpose.

6. To arrive at a fair decision, the Referee may consider any available evidence which the Referee thinks necessary, including a film, picture or image produced by an official video recorder, or any available video evidence.

NOTE 1: *Effort shall be made to reach Referee consensus. Without such, the Video Referee shall prevail, except in cases concerning the start.*

NOTE 2: *For Youth Athletics exception see Rule 119.4c.*

7. The appropriate Referee shall check all final results, shall deal with any disputed points and where there is no Measurement Judge (electronics), shall supervise the measurements of record performances. At the conclusion of each event, the official competition results shall be completed immediately, verified by signature if possible by the appropriate Referee or designee, and delivered to the Competition Secretary.

8. In the event of record performances, the appropriate Referee shall certify the result and duly note such on the appropriate form.

9. A Referee shall have the authority to warn or disqualify from competition any competitor or relay team for acting in an unsporting or improper manner or under Rule 162.17 or for violating any competition rule that states the possibility of disqualification. Warnings may be indicated to the competitor by showing a yellow card, disqualifications by showing a red card. Warnings and disqualifications shall be entered on the results card. Those warnings and disqualifications decided by the Referee shall be communicated to the Competition Secretary and to the other Referees. In disciplinary matters, the clerking area Referee has authority starting from the warm-up area up to the competition area. In all other instances, the Referee applicable to the event in which the competitor is or was competing, shall have authority.

NOTE 1: *The Referee may, where the circumstances justify it, disqualify a competitor or relay team without a warning having been given, such as in Rule 144.3(a).*

NOTE 2: *When disqualifying a competitor or relay team from competition under this Rule, if the Referee is aware that a yellow card has already been given, the Referee should show a second yellow card followed immediately by showing a red card.*

NOTE 3: *If a yellow card is given and the Referee is not aware that there is a previous yellow card, it shall, once this is known, have the same consequence as if it was given in association with showing a red card. The relevant Referee shall take immediate action to advise the competitor or relay team or their representative of the disqualification.*

10. For road events, the Referee shall, wherever practicable, give a warning prior to disqualification. See Rule 243.4.
11. If, in the opinion of the appropriate Referee, circumstances arise at any meet such that justice demands that any event or any part of an event should be contested again,

except as indicated in the authority of the Starter, the Referee shall have authority to declare the event or any part of an event void and that it shall be held again, either on the same day or on some future occasion, as the Referee shall decide.

12. The Combined Events Referee shall have jurisdiction over the conduct of the Combined Events competition. This Referee shall also have jurisdiction over the conduct of the respective individual events within the Combined Events competition except in matters within the jurisdiction of an appointed and available Start Referee. However, the running and field event Referees shall retain jurisdiction over the conduct of the respective individual events within the combined events competition if there is no Combined Events Referee.
13. The order of events stated in the official program shall not be changed, nor shall the announced arrangement of heats in any event be added to or altered, except by the Referee.
14. The Referee shall have the power to cancel or postpone to a future date any event, even though the same has actually commenced, if in the Referee's judgment the competition cannot be conducted or completed in a satisfactory manner and in fairness to the competitors and officials. Should any event have actually commenced, it shall be conducted (by the competitors who reported on the first date) at a future date in the same manner as though the competition had never been started. In events where any competitors have been eliminated, the Referee shall determine whether any such competitors may compete on the postponed date and at which point or round the competition should commence.
15. Where an athlete with a physical disability is competing in a competition under these Rules, the appropriate Referee may interpret, or allow a variation from, any relevant Rule (other than Rule 144.3) to enable the participation of the athlete provided that such variation does not provide the athlete with any advantage over another athlete competing in the same event. In the case of any doubt or if the decision is disputed, the matter shall be referred to the Jury of Appeal.
NOTE: *This Rule is not intended to permit the participation of guide runners for visually impaired athletes, unless specifically allowed by the regulations of a particular competition.*

RULE 126 JUDGES

FINISH JUDGES

1. Judges may reconsider any original decision made by them if the decision was made in error, provided the new decision is still applicable. Alternatively, or if a decision has subsequently been made by a Referee or the Jury of Appeal, they shall refer all available information to the Referee or the Jury of Appeal.
2. When an approved imaging device is properly functioning at the finish of an event, the image must be referred to the Photo Finish Judges for the primary determination of the order of finish. In the absence of such a device, the primary determination of the order of the finish shall be made by the Judges at the finish.
3. It is recommended that there be at least four Judges, and normally one more Judge than there are lanes used, at the finish, one of whom shall be designated as Chief Finish Judge, who shall decide the order in which the competitors finish and who shall

assign the other finish Judges to their respective duties if not assigned in advance. The Chief Finish Judge shall only observe the finishes and his/her decision shall be given only in the case of a tie vote on the part of the other Judges. In case of a disagreement, the majority of the Judges concerned with the disputed place(s) shall decide, and if there is a tie vote on the part of such Judges, the Chief Finish Judge shall decide.

NOTE: *When two or more independent Photo Finish systems are being used, the number of finish line officials may be reduced to no less than four with Timers and Finish Judges.*

4. When possible, Judges shall be placed on the same side of the track, at least 5m back from and in line with the finish, on an elevated platform.

FIELD JUDGES

5. A Head Field Judge shall be appointed, if there is no Field Event Referee.
6. The Chief Field Judge of each event shall perform the appropriate facility verification and certification if for any reason such certification is not given by the Technical Manager. The Chief Field Judge of each event shall allocate the duties of each Judge in the event if not assigned in advance, and coordinate the work of the Judges.
7. The Chief Field Judge in each field event should not have or assume any duties that will prevent or interfere with the ability to determine the validity of any performance by any competitor.
8. Two Judges should keep a record of all trials.
9. The appropriate Field Judge(s) shall, at the completion of a trial, normally indicate a valid performance by raising a white flag and shall normally indicate a foul or non-valid performance by raising a red flag. An alternate visual indication may be approved by the Games Committee. The Judge may reconsider a decision if he/she believes an incorrect flag was raised. See Rules 180.12 & 180.13.

NOTE: *It is recommended that for each field event only one set of white and red flags is used in order to reduce the possibility of any confusion about the validity of a trial. It is most probably never necessary to use more than one set of flags in a jumping event.*

For throwing events, it is recommended that an alternate form of indication to flags is used such as:

a. For circle or line Judges, to the Judge with the flags, a small red card held in that Judge's hand to indicate that a failure has been made;

b. For a landing of an implement on or outside the sector line, a Judge's outstretched arm parallel to the ground and pointing to the outside of the sector;

c. For a judgment in the Javelin Throw that the metal head has not touched the ground before any other part of the javelin, the pushing of the open hand of the Judge towards the ground to indicate a foul.

RULE 127 UMPIRES

1. The Chief Umpire, who is directly responsible to the Referee, shall generally supervise Umpires. The Chief Umpire shall:
 - (a) Brief and review with Umpires the appropriate rules of competition and any special regulations established for the competition by the Games Committee or the Referee;
 - (b) Place Umpires at locations where they may best perform their duties;
 - (c) Secure from Umpires complete details, both orally and written, of any alleged violations and immediately submit the report of the alleged violation to the Referee; and
 - (d) Check the number, condition, and height of the hurdles and the placement and distance between hurdles in the event no Hurdle Inspector or other official has been appointed to do so.
2. Umpires are assistants to the Referee, to whom the Chief Umpire shall report, and have no authority to make final decisions.
3. Umpires, among other things, should be assigned to oversee the conduct of hurdle races and the passing of batons at the exchange zones in relay events. For each exchange zone conducted in lanes, a designated Umpire shall ensure that the competitors are correctly placed in their exchange zones. The designated Umpire shall also ensure that Rule 170.5 is observed.
4. It shall be the duty of an Umpire to:
 - (a) Stand at such point as the Referee or Chief Umpire may designate;
 - (b) Watch the competition closely and, in case of a foul or violation of the rules by a competitor or other person, communicate such breach by either raising a yellow flag or using other reliable means approved by the Games Committee; and
 - (c) Report, orally and in writing, to the Chief Umpire what he/she saw of the incident, even if the competitor or team does not finish the race.
5. When an Umpire observes that a competitor has run in a lane other than the assigned lane or that a relay baton has been passed outside the exchange zone, the umpire should immediately mark the track with a suitable non-permanent material where the incident occurred or make a similar notation on paper or by electronic means.
6. In walking events, the assigned Umpires shall perform their duties as in any other event, but shall not be responsible for technique rules, which are the responsibility of the Judges of Race Walking.

RULE 128 TIMERS, PHOTO FINISH JUDGES, TRANSPONDER TIMING JUDGES

1. When an approved imaging device is properly functioning at the finish of an event, the image must be referred to the Photo Finish Judges for the primary determination of the finish times for each competitor. In the absence, or failure, of such a device, the

primary determination of the finish times shall be made by the Timers at the finish. Timers at the finish shall also be the back-up for races authorized to use a Transponder Timing system. Timers, Photo Finish Judges and Transponder Timing Judges shall act in accordance with Rule 165.

2. A certified official shall be designated as Chief Timer.
3. The Chief Timer, among other things, shall:
 - (a) Determine that all running and walking events are hand timed in accordance with these rules;
 - (b) Assign to Timers their assignments;
 - (c) Supervise the recording of all hand times taken;
 - (d) Make note of the records for the events to be timed, so an immediate check can be made in the event of record performances;
 - (e) In the event of a record performance, inspect the watches of the Timers involved and in the case of not Photo Finish, certify on the official record application form the times recorded by such Timers, who shall also sign the record application form; and
 - (f) When feasible, examine all watches prior to competition to determine their accuracy.
4. There shall be three Official Timers and one or two Alternate Timers, who shall time the winner of each event. The time recorded by the Alternate Timers shall not be considered unless one or more of the Official Timers' watches fails to properly record the time, in which event the Alternate Timers shall be called upon in such order as has been previously determined so that, if possible, in all races three watches shall have recorded the official winning time. Times for all finishers shall be recorded.

NOTE 1: *It is recommended that there be four more Timers than there are places being recorded (Chief Timer, two additional first place Timers and one alternate).*

NOTE 2: *When one Photo Finish system is used, the Timers prescribed in Rule 128.4 should be used in a back-up capacity. When two independent systems are in use, a reduction may be made to one Official Timer and one Alternate Timer who should each time the winner. No back-up capacity is suggested when more than two independent systems are used.*
5. When it is feasible to do so, intermediate or lap times should be recorded in races of 800 meters and over and at every 1000m in races of 3000 meters and over. Split times should be given to all competitors in events longer than 400 meters either by use of a visible time clock, orally, or both. For races partially or entirely off the track, split times should be given to the competitors either by a visible time clock, orally, or both at appropriate locations on the course.
6. When a Photo Finish device is used, the Chief Photo Finish Judge shall be responsible for the functioning of the system and before the start of competition, meet with the technical staff involved to become familiar with the equipment, checking all applicable settings. At the beginning of each session, the Chief Photo Finish Judge, in cooperation with the Chief Photo Finish Operator, the Starter and the Referee, shall

initiate and supervise tests to ensure that the Photo Finish equipment complies with the alignment, automation and zero control function specified in Rule 165.10(a).

7. The Chief Photo Finish Judge shall determine the places of the competitors and their respective times. He shall then record and certify them, or ensure that they are correctly entered into the competition results system for forwarding to the Competition Secretary and/or such other officials designated by the Games Committee or Meet Director. Results shall subsequently be certified as official by the Referee or the Referee's designee. The determinations of the Photo Finish Judges may be appealed to the Referee for a final determination.
8. The Chief Transponder Timing Judge shall be responsible for the functioning of the System. Before the start of the competition, this judge will meet the technical staff involved, become familiar with the equipment, shall supervise the testing of the equipment and ensure that the passing of the transponder over the finish line will record the competitor's finish time. In conjunction with the Referee, the Chief Transponder Timing judge shall ensure that provision is made for the application of Rule 165.15(g).
9. In the event of record performances, the Referee should certify the times and duly note them on the records of the Photo Finish Judges. In the event of a record performance, the Chief Photo Finish Judge shall certify on the official record application form the time recorded for such record, and also sign the record application form. If a record is timed by a videotape based system or a computer based system, a printed picture shall be made where required.

RULE 129 STARTER AND RECALL STARTER

1. The Chief Starter shall:
 - (a) Allocate the duties of the start team judges, assigning the task of giving the start to the member of the team who, in the opinion of the Chief Starter, is best for the event.
 - (b) Supervise the duties to be performed by members of the team.
 - (c) Inform the Starter, after receiving the relevant order from the Competition Director or otherwise ascertaining, that everything is in order to initiate the start procedure (i.e., the applicable Timers, Judges, Photo Finish Operators and Wind Gauge Operator are ready).
 - (d) Act as an interlocutor between the technical staff of the timing equipment company and the judges.
 - (e) Keep all papers produced during the start procedure including all documents showing the reaction times and/or false start waveform images if available, and deliver these to the Competition Secretary.
2. The primary responsibility of the Starter and Recall Starters is to ensure a fair and equitable start for all competitors at the start line.

3. The Starter shall have entire control of the competitors at their marks and shall be the sole judge, except as herein otherwise provided, of whether or not any competitor has committed a false start. See Rule 162 for method of starting.
4. One or more Recall Starters shall be assigned when possible to assist the Starter. Each Recall Starter is obliged to recall the race if any **infringement of the Rules** is observed. They shall have the authority to recall the competitors, by appropriate means, in any race in which, in his/her opinion or that of the Starter, the start was not fair. If Recall Starters are assigned to observe one or more competitors, they shall place themselves so that each competitor can be clearly seen. After a recalled or aborted start the Recall Starter shall report his observations to the Starter who shall decide whether and to whom a warning or disqualification shall be issued.
NOTE 1: *For races conducted with a staggered start, it is recommended that there be at least two Recall Starters.*
NOTE 2: *For disciplinary infringements the decision is made by the Referee. See Rule 162.17.*
5. Notification of warnings and disqualifications concerning the start may be made only by or under the direction of the Starter.
6. The Starters shall be clearly identifiable and shall be positioned so that there is full visual control over all runners during the start of the race.

RULE 130
STARTER'S ASSISTANT / LINE CLERK

1. Upon receiving the competitors in transit from the Call Room, the Starter's Assistant shall verify the presence of each competitor as indicated on the start list for that heat or race. Verification of correct bib and other numerical identifiers, as well as their use on the uniform, shall also occur.
2. The Starter's Assistant shall place each competitor in the correct lane or position. The Starter's Assistant shall place the competitors "under the control of the Starter" by assembling them in each lane or on the common start line, at the direction of the Starter between 1m and 3m behind the start line, with each competitor in a standing position and facing in the direction of the race. When this has been completed, the assigned Starter's Assistant shall signal to the Starter that all is ready. When a new start is ordered, the assembly shall occur again.
3. The Starter's Assistant shall advise the Starter of the number of races in the event, empty lanes and any other conditions pertinent to the assembly of the competitors.
4. The Starter's Assistant shall be responsible for the readiness of batons for the first leg competitor in a relay race.
5. The Starter's Assistant shall be the Start Line point of information regarding qualifying and / or advancement procedures for the event and event procedure including staggers and breakpoints.
6. The Starter's Assistant shall coordinate with media presentation personnel to have competitors in place for appropriate introductions.

7. In handicap events starting from marks, the Starter's Assistant shall place each competitor behind the proper mark.
8. In time allowance handicap events, competitors shall be assigned their positions by the Starter's Assistant, who shall also furnish the Starter with the number and time allowance of each competitor.

RULE 131 LAP SCORERS

1. Lap Scorers shall keep a record of the laps covered by each competitor in races longer than one mile. For races of 3 miles and over (3000 meters and over in indoor races), Lap Scorers shall also record on their lap scoring cards the times over each lap (as given them by an Official Timer) of the competitors for whom they are responsible. No Lap Scorer should be responsible for more than three competitors (six in the case of ultramarathons and road walking events).
NOTE: *Whenever possible, an adequate number of trained lap scorers should be selected before the day of competition.*
2. At the completion of each race, lap scoring cards shall be delivered to the Referee.
3. One lap scorer shall be responsible for maintaining at the finish line a display of the laps remaining. The display shall be changed each lap when the leader enters the straight that ends at the finish line. In addition, manual indications shall be given, when appropriate, to competitors who have been, or are about to be, lapped. The final lap shall be signaled to each competitor, usually by ringing a bell.
4. Transponder systems complying with Rule 165.15 may be used for lap scoring.

RULE 132 COMPETITION SECRETARY / TECHNICAL INFORMATION CENTER (TIC)

1. The Competition Secretary shall have the responsibility of preparing all entrant and start lists referred to in Rule 10 and Rule 11, or otherwise as appropriate, and worksheets for use by other officials. The Competition Secretary shall work closely with the Clerk of Course and the Referee in the reforming of heats and the preparation of start lists for subsequent rounds of competition. The Competition Secretary shall cause all start lists, including any amendments to start lists, to be distributed appropriately to other officials.
2. The Competition Secretary shall collect the results of each event, together with times, Photo Finish pictures, heights or distances furnished by the Judges and Timers or other officials, and the wind gauge information provided by the Wind Gauge Operator. As soon as possible thereafter, he/she shall communicate such information to the Announcer, Press Steward, or other appropriate officials and, after recording the places, times, heights, distances, and wind gauge readings, he/she shall deliver the official results, together with all official cards and Photo Finish pictures, to the Meet Director. The Competition Secretary shall keep a log that records the time of day and method of all results publications.
3. In events in which athletes are competing with different specifications, such as implement weight or hurdle heights, the relevant differences should be clearly indicated in the results or a separate result shown for each category.

4. The following standard markings should be used in the preparation of start lists and results where applicable:
- | | |
|--|---|
| Did not start: DNS | Qualified by place in track events: Q |
| Did not finish: DNF | Qualified by time in track events: q |
| Disqualified: DQ | Qualified by standard in field events: Q |
| Competing under Protest: P | Qualified without standard in field events: q |
| No valid trial recorded: NM | Advanced to next round by Referee: qR |
| Valid trial in High Jump/Pole Vault: O | Advanced to next round by Jury of Appeal: qJ |
| Valid trial other field event: measure | Advanced to next round by draw: qD |
| Failed trial field event: X | Bent knee: ' > ' |
| Forgoes or Pass in field event: – | Loss of contact: ' - ' |
| Lane violation noted without DQ - L | Yellow Card: YC |
| Lane infringement DQ: L:Rule 163.5 | Second Yellow Card: YRC |
| Retired (Field Event): r | Red Card – RC |

NOTE 1: *A competitor shall be considered as DNS if:*

- (a) *after his/her name having been included on the start list for an event, he/she does not report to the Call Room for that event; or*
- (b) *having passed through the Call Room, he/she does not make any attempt in a field event or does not attempt to make a start in a running or race-walking event or does not make any attempt in the first event of a combined Event; or*
- (c) *if Rule 200.8 applies.*

NOTE 2: *For warnings and disqualifications, rule reference should be noted.*

5. The Competition Secretary shall oversee the scoring of team competition, combined events and handicap races.
6. A Technical Information Center (TIC) shall be established for competitions held under Rule 10 and Rule 11 and is recommended for other competitions held over more than one day. It may be a virtual or physical operation, or a combination of both. The main function of the TIC is to ensure smooth communication between each competitor, the Games Committee, the Meet Director and the Competition Director regarding technical and other matters relating to the competition.

RULE 133 MARSHAL

The Marshal shall have full charge of the areas used for competition, shall allow only persons with valid accreditations to enter or remain therein, and shall limit all persons from interfering with the fair, orderly and sporting conduct of the meet. Marshals shall be easily identifiable. The Chief Marshal shall supervise and assign respective duties to the Marshal's assistants.

RULE 134 WIND GAUGE OPERATOR

1. The Wind Gauge Operator, except as provided in Rule 163.14, shall maintain the wind gauge, and take and record in writing, on the forms provided for that purpose by the Competition Secretary, the wind velocity in the direction of running for all running events (including hurdles events) up to and including the 200 Meters and the Long Jump and Triple Jump. The Wind Gauge Operator shall report each wind gauge measurement to the appropriate recorder for each event and shall provide a compilation of all measurements to the Competition Secretary.

2. Whenever the wind gauge is connected to a computer system, a Wind Gauge Operator may be appointed to ensure that such wind gauge is properly transmitting the wind readings to the computer and that the computer is properly recording those readings. Otherwise, the above duties shall be fulfilled by a member of the Photo Finish team.

NOTE: *For wind gauge placement and operation see Rule 163.10 through Rule 163.14.*

RULE 135 ELECTRONIC MEASUREMENT JUDGE

1. One Chief Measurement Judge and an adequate number of assistants shall be appointed when any technological or scientific distance measurement is to be used.
2. Before the meet, this Judge shall meet with the technical staff and the operators of electronic distance measuring and data recording devices to become familiar with the specific equipment and the personnel.
3. Before each event where the device is used, the Judge shall supervise the positioning of the measuring instruments, taking account of the technical requirements given by the manufacturer, the instrument calibration specifications and the needs of the event chief.
4. To ensure that the equipment is operating correctly, the Judge shall, before and after each event, personally supervise or conduct a set of measurements in conjunction with the equipment operator under the supervision of the Referee to verify the accuracy of the device against a known distance, such as certified steel tape or an independently certified distance such as 100m. A form of conformity shall be issued, signed by all those involved in the test and attached to the results card.
5. During the competition the Judge shall remain in overall charge of the operators and equipment operation so that the Judge can report to the Field Events Referee that the equipment is accurate and operating properly during the competition.

RULE 136 CLERK OF COURSE / CALL ROOM

1. The Clerk of the Course shall, in conjunction with Meet Management, prepare, publish and post a Call Room Schedule setting out for each event at least the first and final entry times for each Call Room in use and the time at which the competitors will depart for the competition area from the final Call Room.
2. The Clerk of Course shall control the Assistant Clerks of Course and assign them to such duties as deemed proper.
3. The Clerk of Course shall be provided with the names and the numbers of all competitors entered in running or walking events, and he/she shall notify them to appear at the start line or other assembly area before the start in each event in which they are entered.
4. The Clerk of Course shall supervise the transit between each individual Call Room and to the competition area to ensure that the competitors after being checked-in are present and ready for the scheduled start of their event.

5. The Clerk of Course, and Assistants, shall ensure that competitors are wearing clothing, shoes, and spikes which are in accordance with USATF Rules. The Clerk shall verify that bibs correspond to those on the start list and are worn correctly. The Clerk shall also be responsible for distribution and proper placement of additional identification items used to aid in announcing and judging.

RULE 139 ADDITIONAL OFFICIALS

1. **Finish Line Coordinator:** The Finish Line Coordinator shall be responsible for alerting all finish line officials that a track event is about to begin and to ensure that these officials are ready to perform their assigned duties prior to the start of that event. When this is accomplished, the Finish Line Coordinator shall inform the Starter of this condition. It is also the duty of the Finish Line Coordinator to ensure that the finish line area is free of all unauthorized personnel during the start, the progress, and the finish of a track event. A Finish Line Coordinator may be assigned to assist the Chief Finish Line Judge and/or Chief Timer in recording times and places.
2. **Inspector of Implements:** The Inspector of Implements shall weigh and measure implements used in competition, and shall place a designating mark on each implement passed as complying with all relevant specifications. He/she shall impound the non-complying ones for the duration of the competition. In an event that includes a qualifying round, he/she shall impound all implements that will be available for the final competition between the qualifying round and the competition proper. Under special circumstances (e.g., implements are damaged), the Referee may authorize the Inspector of Implements to certify additional implements between the qualifying round and the competition proper.
3. **Recorder of Records:** For all meets there shall be included in the list of officials a Recorder of Records. He/she shall see that records are properly applied for. He/she shall have at the site of the competition an adequate supply of record forms. He/she should have no other duties.
4. **Combined Events Coordinator:** A Combined Events Coordinator may be assigned for the Combined Events. He/she shall be present at all times to assist in the conduct of the event and shall report to the assigned Referee.

RULE 140 COMPETITION AREA

The competition area is defined by the Games Committee. It is normally the area where the competition is being staged, physically separated from the area used by spectators. The designated areas, including that at road races, shall be clearly marked with fencing, banners, flags, or other suitable material to clearly indicate which area has access restricted to competing athletes and other authorized personnel.

**ARTICLE IV
RULES OF COMPETITION**

**SECTION I
GENERAL**

**RULE 141
CLASSIFICATIONS**

1. Except as otherwise provided herein or in USATF's Operating Regulations, the following championship classifications shall be open to all member athletes of USATF who have complied with the requirements of these Rules, the Bylaws, and the Operating Regulations:

NOTE: *For USATF qualifying competitions, age restrictions for the event to which the meet is a qualifier may impact a competitor's classification and/or eligibility within the USATF competition.*

- (a) Open: The Open classification shall have no maximum age limit.
- i. In Men's and Women's Track and Field and Men's and Women's Race Walking, athletes shall be fourteen (14) years of age or older on the day of the competition.
- ii. In Men's and Women's Cross Country / Long Distance Running, this classification shall be limited to athletes sixteen (16) years of age or older on the day of the competition.
- (b) U20: The U20 (formerly Junior) classification shall be limited to athletes who are fourteen (14) years or older on the day of competition and will not become twenty (20) years of age during the year of the competition.
- (c) Youth: The Youth classification shall be limited to athletes who have not attained nineteen (19) years of age as of the final day of the National Junior Olympic Track and Field meet of the year of competition.

NOTE: *This is not the same as the World Athletics definition of Youth, which is U18.*

- (d) Masters: The Masters classification shall:
- i. In Track and Field and Race Walking, the Masters classification shall be limited to athletes who are at least thirty-five (35) years old on the first day of the meet.
- ii. In Long Distance Running, the Masters classification shall be limited to athletes who are at least forty (40) years old on the first day of the meet.

NOTE: *The USATF Masters starting age for LDR events is different than that defined by WMA or World Athletics.*

2. Participation in the female category in all events at all age groups and types of disability conducted by and / or sanctioned by USA Track & Field, including any and all of their Associations, will be limited to those who are female with female reproductive biology and genetics.
3. Limitations: The following limitations are applicable to all classifications:
- (a) For events longer than the Half Marathon or the 1-Hour event, the age minimum shall be sixteen (16) years of age.

(b) For events longer than the Marathon or 2-Hour event, the age minimum shall be eighteen (18) years of age.

NOTE: *The date for the age calculation for a classification shall be as stated in Rule 141.1.*

RULE 142 COMPETITOR CHECK-IN

1. All runners and walkers shall report to the Clerk of Course / First Call Room and no later than the final check-in time designated in the Call Room Schedule in the entry blank, the meet/Technical Information published and distributed by the Games Committee or posted at each Call Room. All field event competitors shall report to the Chief Field Judge of their respective events at the time designated in the Call Room Schedule unless instructed to report as above.
2. Each competitor shall inform himself/herself of the reporting time in the Call Room Schedule for their event and shall be at the appropriate Call Room(s) to indicate their presence.
3. Failure to Report: In the competitions listed in Rules 10, 11, 13, 27 and the Masters Championships, a competitor shall be excluded from participation, and listed as Did Not Start in the results, in any event in which he/she is not present at the relevant place and final time as prescribed in Rule 142.1 and Rule 142.2, i.e. final check-in time listed for the First Call Room. The relevant Referee shall have the authority to allow participation under protest and may accept justifiable reasons, such as factors independent of the competitor's own actions, (i.e., transportation issues or a faulty published schedule) in rendering a decision. References to any warning or exclusion shall be recorded in the official results of the event.
4. In scored competitions, an athlete shall be disqualified from participation in all further events in the competition, including other events in which participation is occurring simultaneously, where:
 - (a) A final confirmation was given that the athlete would start in an event but then failed to participate;
NOTE: *A fixed time for the final confirmation of participation shall be published in advance.*
 - (b) An athlete qualified in a qualification round of an event for further participation in that event but then failed to participate further;
 - (c) An athlete failed to compete honestly, with bona fide effort. The relevant Referee will decide on this and a corresponding reference made in the official results.
NOTE 1: *The situation foreseen in (c) shall not apply to the individual events of a Combined Event.*
NOTE 2: *Passing in a field event is an allowable action by a competitor and does not constitute failure to participate.*
 - (d) This rule shall not apply to track events in which only a final is held, but an athlete may be barred from such an event if previously he or she has not honestly participated in a track event within the purview of this rule.
NOTE: *For Youth Athletics exception see Rule 302.2(h). For Masters exception see Rule 332.1(d).*

5. The Referee has the discretion to waive the honest participation rule in the event an athlete provides a medical certificate, based on an examination by a medical officer appointed or approved by USATF or the Games Committee, attesting to the fact that the athlete became unable to compete after being declared, or after competing in a previous round, but will be able to compete in further events on a subsequent day of the competition. Other justifiable reasons, such as factors independent of the athlete's own actions, may, after confirmation, also be accepted by the Referee.

RULE 143 ATHLETIC ATTIRE

1. In all events competitors must wear clothing that is clean, designed, and worn so as not to be objectionable. The clothing must be made of a material that is not transparent even if wet. The competitors must not wear clothing that could impede the view of the judges. The size or number of logos on athletes' attire shall be restricted only when required by World Athletics or USOPC. This rule shall be enforced by the Clerk of the Course for track and road events and the Chief Judge of each field event.

NOTE: *In Race Walking, athletes shall not wear clothing that prevents a clear and complete view of the knee area. However, solid color long tights that are adherent to the athletes' legs are allowed.*

2. In hot weather, an athlete competing in a Long Distance race (road, track, mountain, or trail) may compete without a top shirt. This ruling shall be made by the Referee with the approval of the Games Committee.

Shoes –

3. (a) This rule shall encompass all definitions, limitations, verifications, penalties and other procedures set forth in World Athletics Technical Rule 5 as it pertains to shoes. The following paragraphs are not meant to supersede but to provide general access to that rule.

NOTE: *World Athletics List of Approved Shoes can be found at:*

<https://worldathletics.org/about-iaaf/documents/technical-information>

- (b) A competitor may compete in bare feet or with footwear on one or both feet. The purpose of shoes for competition is to give protection and stability to the feet and a firm grip of the ground. Such shoes, however, must not be constructed so as to give the competitor any unfair assistance or advantage. Any type of shoe must be reasonably available to all in the spirit of universality of the sport.
- (c) A shoe that meets the criteria set out in this rule may be customized to suit the characteristic of a particular competitor's foot. However, one-off shoes made to order (i.e. that are the only ones of their kind) to suit the characteristic of a competitor's foot or other requirements are not permitted.
- (d) Where USATF has reason to believe that a type of shoe or specific technology may not comply with the letter or spirit of the rules, USATF may refer the shoe or technology for detailed examination and it may prohibit the use of such shoes or technology in competition pending examination.
- (e) The sole of the shoe (including the part beneath the competitor's heel) may be so constructed as to provide for the use of up to 11 spikes. Any number of spikes up to 11 may be used, but the number of spike positions shall not exceed 11.

NOTE: *For Youth Athletics Javelin exception see Rule 302.5(f).*

- (f) When a competition is conducted on a synthetic surface, that part of each spike which projects from the sole or heel, must not exceed 9mm, except in the High Jump and Javelin Throw, where it must not exceed 12mm. If the facility operator mandates a lesser maximum, or prohibits the use of certain shaped spikes, this shall apply and the competitors notified accordingly. For non-synthetic surfaces, the maximum length of spike shall be 25mm. Each spike must be constructed so that it will, at least for the half of its length closest to the tip, fit through a square sided 4mm gauge.

NOTE: *For Cross Country competitions, the entry material/Technical Information or the Games Committee may allow the use of an increased spike length.*

- (g) The sole of the shoe (including the part beneath the competitor's heel) may have grooves, ridges, indentations, or protuberances, provided these features are constructed of the same or similar material to the basic sole itself.
- (h) For all field events, the sole at the center of the athlete's forefoot must not be higher than the sole at the center of the athlete's heel.
- (i) For Men's and Women's Track and Field and Long Distance Running and Race Walking, shoes shall comply with World Athletics rules. The maximum thickness of the sole is:
- For all field events– 20mm,
 - For all track events 20mm,
 - For cross country – 25mm spiked or 40mm non-spiked,
 - For road events and Race Walking events – 40mm,

NOTE: *Effective November 1, 2024, the specification for the Triple Jump shoe is also 20mm.*

- (j) For Masters events, shoes shall comply with WMA rules.
As of January 2021, shoes with spikes shall have a maximum thickness of 30 mm and shoes without spikes shall have a maximum thickness of 40 mm.
- (k) For Mountain and Trail races there are no limitations.
- (l) For Ultramarathon off-track races and track races that are not World Athletics record events, shoes shall have a maximum thickness of 40 mm
- (m) For Youth Athletics competitions there are no limitations on shoes.
- (n) Athletes may not use appliances, either inside or outside the shoe, which will have the effect of increasing the thickness of the sole above the permitted maximum, or which can give the wearer any advantage which would not be obtained from the type of shoe described in the previous paragraphs. The thickness of the sole shall be measured as the distance between the inside top side and the outside under side that contacts the ground, including the above-mentioned features and any kind or form of loose inner sole.

NOTE: *Orthotic inserts required for medical purposes are exempt from this rule.*

- (o) If the Referee has reasonable suspicion that a shoe worn by a competitor in a competition might not comply with the letter or spirit of the rules, the Referee may request and the competitor shall immediately hand over the shoe to the

Referee at the conclusion of the event for further examination by USATF. However, where it has already been declared that a shoe does not comply, the Referee shall immediately disqualify the competitor.

Bibs –

4. The overall size of the bib shall not exceed 16cm x 24cm. The numerals on the bib should be at least 6cm in height. The sponsor's name shall not exceed 2.5cm x 15cm. **NOTE:** *Youth Athletics and road races, except for the size of the name of the sponsor, may vary the overall height of the numeral.*
5. (a) When bib(s) are provided, every competitor shall wear them, as indicated in these rules, when competing.

(b) If one bib is provided, it must be worn visibly on the front. When two bibs are provided, they must be worn on the singlet, front and back. If, pursuant to Rule 143.2, a singlet is not worn, the bibs should be worn on the shorts, front and back. The competitors may also be required to wear start list identifying numbers visibly on the hips and in other locations determined by the Games Committee.

(c) No athlete shall be permitted to participate in any competition without the appropriate bib, except as indicated in these rules. Bibs are to be worn as issued (cutting or folding numbers shall not be permitted). The identifying information on the bib need not be numeric. It shall be of sufficient font type, size and contrast for clear visibility. Not wearing an assigned bib may be grounds for disqualification under Rule 145.2.
NOTE: *For Masters exception see Rule 341.6.*
6. In the Jumping Events, the competitors may wear the bib on the back or front only.
7. In Cross Country, Long Distance Running, and Race Walking the competitors shall wear a bib on the front and in Race Walking, also on the back. The bib(s) shall be visible at all times during the competition. Failure to do so may result in disqualification from the event.
8. Where athletes compete in warm-up suits, the bibs must be worn on that suit as set forth herein.
9. Once a number has been assigned to a competitor, no other competitor may use it.
10. A Transponder Timing device and other identification issued by the Games Committee shall be worn according to instructions. Failure to do so may result in disqualification from the event.

**RULE 144
ASSISTANCE TO ATHLETES**

1. Competition under these Rules consists of self-propelled motion without assistance, except as defined by the Rules of Competition of a specific event discipline.
NOTE 1: *For athletes with disabilities entering open competitions, refer to the "USATF Policy and Procedures for Evaluation of Requests for Accommodations Pursuant to the Americans with Disabilities Act"*
<https://www.usatf.org/events/event-resource-pages/ada-event-accommodations>

NOTE 2: For rules covering disabled-only competitions see the *SPECIAL SECTION* which follows *ILLUSTRATIONS* in this rule book.

2. Except as provided in road races (Rule 241) and in long distance walking events (Rule 232), during the progress of an event a competitor who has received any assistance whatsoever may be disqualified by the Referee. "Assistance" is the conveying of advice, information or direct help to a competitor by any means, including a technical device.
3. **The following shall be considered examples of assistance:**
 - (a) Pacing in running or walking events by persons not participating in the event, by competitors lapped or about to be lapped, or by any kind of technical device other than those permitted under Rule 144.4(f), Rule 144.4(g) and Rule 144.4(h). See Rule 250 through Rule 252 for Cross Country, Mountain and Trail Running.

- (b) The visible possession or use by athletes of video, audio, or communications devices in the competition area. The Games Committee for an LDR event may allow the use of portable listening devices not capable of receiving communication; however, those competing in championships for awards, medals, or prize money may not use such devices. See Rule 250 through Rule 252 for Cross Country, Mountain and Trail Running.
 - (c) The use of any technology or appliance that provides the user with an unfair advantage which would not have been obtainable using equipment complying with the Rules.

NOTE: Shoes complying with Rule 143 are permitted.

- (d) The use of any mechanical aid, unless the competitor can establish on the balance of probabilities that the use of such an aid would not provide an overall competitive advantage over a competitor not using such aid.
 - (e) Provision of advice or other support by any official of the competition not related to, required or allowed by the specific role of the official in the competition at the time. This includes items such as coaching advice, providing take-off point information in a jumping event, and time or distance gaps in a race. Specifically excluded from providing assistance is indicating the take-off point for a failure in the horizontal jumps, time announcements allowed in Rule 163.15.
 - (f) Receiving physical support from another (other than from another competitor in the event helping to recover to a standing position) that assists in making forward progress in the race.
4. **The following shall not be considered assistance:**
 - (a) Verbal or other communication, without the use of any technical device, from an individual who is not in the competition area to a competitor who is in the competition area. In order to facilitate this communication and not to disturb the staging of the competition, it is recommended that a place in the stands, close to the immediate site of each field event, be reserved for the competitors' coaches.

NOTE: Coaches complying otherwise with Rule 241.2 may communicate with their competitors.

- (b) Physiotherapy and/or medical treatment necessary to enable an athlete to participate, or continue participation once in the competition area, may be

provided by members of the official medical staff appointed by the Games Committee and clearly identified as such. Accredited team medical personnel approved by the Meet Doctor specifically for this purpose may be permitted in the medical treatment area outside the competition area. In neither case shall the intervention delay the conduct of the competition or a competitor's trial in the designated order. Such attendance or assistance by any other person, whether immediately before competition once an athlete has left the Clerking area, or during the competition, is assistance under Rule 144.6.

- (c) Medical personnel authorized by the Games Committee or Referee to do so may perform a hands-on medical examination during the progress of an event for any competitor who appears in distress. If in their opinion it is in the best interest of the competitor's health and welfare, they may remove the competitor from the competition.
- (d) Receiving physical support from an official or other person designated by the Games Committee to recover to a standing position or to access medical assistance.
- (e) Any kind of personal safeguard (i.e., bandage, tape, belt, support, wrist cooler, breathing aid, etc.) for medical purposes. The Referee shall have the authority to verify any case should that be desired.
- (f) Pace setting by an officially designated person entered in an event for that purpose is permitted, provided such pacesetters start in the event.
- (g) Personally carrying or wearing articles of equipment such as wrist chronometers, heart rate monitors, speed distance monitors, stride sensors or similar devices during a race provided that such device cannot be used to communicate with any other person.
- (h) Electronic lights or similar appliance indicating progressive times during a race, including a relevant record.
- (i) Viewing by athletes competing in field events, of images of trial(s), recorded on their behalf by persons not placed in the competition area, without contravening any other rule. See Rule 144.3(b). The viewing device or images taken from it shall not be taken into the competition area beyond the immediate area in which those providing the recording are permitted.

NOTE 1: *To facilitate a better view of the images, the competitor may hold the device whilst communicating with those who have taken the images.*

NOTE 2: *For Youth Athletics exception see Rule 302.5(s).*

- (j) Hats, gloves, shoes and other items of clothing provided to competitors at official stations.

- (k) Athletes running in close proximity to one another.

NOTE: *Where ultramarathon events include multiple distances running concurrently on the same loop course and/or a large number of laps, this allowance also applies to those athletes running different distances and/or are on different laps. See note at the end of this Rule.*

5. In a track event, any competitor competing to lose or to coach another competitor shall forfeit the right to be in the competition and shall be disqualified.
6. Any athlete giving or receiving assistance during any event other than permitted in Rule 144.4 must be cautioned by the Referee and warned that for any repetition, he or she will be disqualified from that event. If such disqualification occurs, any performance accomplished up to that time in the same event session shall not be considered valid. Performances accomplished in any previous event session, such as a qualifying round, shall stand.

NOTE 1: *For Youth Athletics exception see Rule 302.5(j).*

NOTE 2: *Information conveyed to an athlete by an official is not considered assistance provided such information is made available to all athletes.*

NOTE 3: *In cases under Rule 144.3(a) or Rule 144.3(f), disqualifications may be made without warning.*

7. No attendant or competitor who is not actually taking part in the competition shall accompany any competitor on the mark or in the competition, nor shall any competitor be allowed, without the permission of the Referee or Judges, to receive assistance or refreshment from anyone during the progress of the competition, except as provided by Rules 144.3(b), 145.5, 232, or 241.
8. A competitor may, at any time, carry water or refreshment by hand or attached to his/her body provided it was carried from the start or collected or received at an official station.
9.
 - (a) In races of 5000 Meters through 10,000 Meters, the meet organizers may furnish competitors with water and sponging stations on the track and in off-track events.
 - (b) In Track Events longer than 10,000m, water shall be provided; sponging stations and refreshments may be provided. Refreshments may be provided by either the Games Committee or the athlete and shall be placed so that they are easily accessible to, or may be put by authorized persons into the hands of the athletes. Refreshments provided by the athletes shall be kept under the supervision of officials designated by the Games Committee from the time that the refreshments are lodged by the athletes or their representatives. See Rules 232 and 241.
 - (c) A competitor who receives or collects refreshment or water from a place other than the official stations, except where provided for medical reasons from or under the direction of race officials, or takes the refreshment of another competitor, should, for a first such offense, be warned by the Referee normally by showing a yellow card. For a second offense, the Referee shall disqualify the competitor, normally by showing a red card. The competitor shall then immediately leave the course.

NOTE: *A competitor may receive from or pass to another competitor refreshment, water or sponges provided it was carried from the start or collected or received at an official station. However, any continuous support from a competitor to one or more others in such a way may be regarded as unfair assistance and warnings and/or disqualifications as outlined above may be applied.*

RULE 145 DISQUALIFICATION

1. If an athlete is disqualified from an event because of an infringement of the USATF Competition Rules, reference to the USATF Rule infringed shall be made in the

official results. Any performance accomplished up to that time in the same session of the event shall not be considered valid. Performances accomplished in any previous event session, such as a qualifying round, or previous events of a combined event, shall stand. This disqualification shall not prevent an athlete from participating in any future event or round of an event.

2. Any competitor who shall refuse to obey the directions of the Referee or other proper official, or who shall conduct himself/herself in an unsporting manner, or who is offensive by action or language to the officials, spectators, or competitors at any competition, or under Rule 162.17, shall render that competitor liable to disqualification by the Referee from participation in all further events or rounds of events, including individual events of a Combined Event, simultaneous events and relays, at the meet. If such disqualification occurs, any performance accomplished up to that time in the same event session shall not be considered valid. Performances accomplished in any previous event session, such as a qualifying round or previous events of a combined event, shall stand. If the Referee thinks the offense worthy of additional action, he/she shall promptly make detailed statement of the offense to the appropriate National or Association Officer.
3. If a relay team is excluded from competition under Rule 125.9, the team shall be disqualified from that event. Performances accomplished in a previous round of that event shall remain valid. Such disqualification shall not prevent any competitor or relay from that team from taking part in all further events, including individual events of a Combined Event or other events in which an individual or relay is simultaneously participating, in that competition. However, if the behavior of one or more such individual competitors is considered serious enough, Rule 125.9 may be applied to the competitors with applicable consequences.
4. If an athlete is cited for a second (or subsequent) time under Rule 125.9 for acting in an unsporting or improper manner, in different rounds of one event, or in different events, the athlete shall be disqualified from such second (or subsequent) events in accordance with this Rule.
5. Disqualification shall occur for a competitor who does not follow the provision of Rule 143 in any way and
 - (a) refuses the direction of the relevant Referee to comply, or
 - (b) participates in the competition.

RULE 146 PROTESTS

1. Protests concerning the team status or eligibility of an entered competitor must be made to the Chair of the Games Committee prior to the commencement of the meet, or to the Referee during the meet.
2. Protests concerning the result or conduct of a round of an event shall be made to the Referee at once and not later than 30 minutes after the official announcement and /or publication of the result of that round of the event, except for the following:
 - (a) For Men's and Women's Long Distance Running, the time period shall normally be 24 hours, except for the Professional Section of road races, as defined in the race material (website, entry form, etc.), where the time period shall be 30 minutes.

- (b) For Cross Country and Masters Long Distance Running Championships the time period shall be one hour.
 - (c) In the case of events in which final results are not announced on the day of competition, the Games Committee may determine, and announce in the results that are released, a period not to exceed seven (7) days during which protests may be made to the meet or race director.
3. Protests, at the discretion of the Games Committee or the Referee, may be made orally or in writing. For National Championships, they must be made in writing. Any protest should, in the first instance, be made orally to the Referee or to the Chief Official of the event by an athlete, or by an official representative of an athlete. Such person may only protest if they are or have an athlete competing in the same round of the event to which the protest relates or are competing in a competition on which a team points score is being conducted.
 4. An immediate oral protest regarding a decision by the Starter to charge a false start, made by the competitor being charged, shall be accepted by the Start Referee. In order to protect the rights of all concerned and provide the time required to consider all evidence with regard to the charged false start, the competitor shall be allowed the opportunity to compete under protest, unless the evidence of a false start immediately available to the Start Referee is extremely obvious, in which case the protest shall be denied. After that decision, no further opportunity to protest that specifically charged false start shall be available to the competitor.

For an athlete allowed to compete under protest, a red and white (diagonally halved) card shall be raised in front of the athlete. The false start decision of the Starter shall remain in place pending execution of Rule 146.3 and then a determination by the Start Referee.

NOTE 1: *After being allowed to compete under a false start protest, all future false starts charged to the same athlete in the same race shall be treated independently. If in this case a subsequent false start results in disqualification, the Referee may declare all of the athlete's previous false start protests invalid.*

NOTE 2: *An 'extremely obvious' false start is a false start visible to the naked eye of a member of the start team and is recognized without doubt.*

NOTE 3: *Any doubt or situation requiring further investigation shall be sufficient to not deny such protest.*

5. A protest may be based on the failure of the Starter to recall a false start, or under Rule 162.17 to abort a start. The protest may be made only by, or on behalf of, an athlete who should normally have completed the race with bona fide effort. If the protest is upheld, any athlete who committed the false start or whose conduct should have led to the start being aborted, and who was subject to warning or disqualification according to Rule 162.12 or Rule 162.17, shall be warned or disqualified. Whether or not there is any warning or disqualification, the Referee shall have the authority to declare the event or part of the event void and that it or part of it shall be held again if in his/ her opinion justice demands it.
NOTE: *The right of protest and appeal for Rule 146.5 shall apply whether or not a start information system is used.*
6. When a protest is made by or on behalf of a competitor or team which did not finish a race, the Referee shall first ascertain whether the competitor or team was or should

have been disqualified for a breach of the Rule unrelated to the matter raised in the protest. Should that be the case, the protest shall be denied.

7. If an immediate oral protest is made, in order to protect the rights of all concerned:
 - (a) Regarding a decision of a Field Judge that a jump or throw is foul or is invalid, the jump or throw should be measured, if possible. The measurement should be announced only if the protest is upheld.
 - (b) Regarding an attempt during the first three rounds of trials of a horizontal field event that would have advanced the athlete to any subsequent rounds of trials only if the protest or subsequent appeal was upheld; or regarding an attempt in a vertical field event that would advance the athlete to a higher height only if the protest or subsequent appeal was upheld; the Referee may allow the athlete to continue competing under protest to preserve the rights of all concerned.
8. The protested performance of the athlete and any other performance achieved while competing under protest will become valid only if a subsequent decision to that effect is made by the Referee or an appeal to the Jury of Appeal is made and the performance is allowed.

In Field Events where, as a result of a competitor competing 'under protest', another competitor is allowed to continue in the competition when he/she would otherwise not have done so, such competitor's performances and eventual results shall remain valid irrespective of whether the 'under protest' competitor's immediate oral protest is successful.

NOTE: *The first paragraph of this Rule applies to all events, not just Field Events.*

9. If possible, the Games Committee or the Referee shall decide protests at once. If the nature of the protest or the necessity of obtaining testimony or evidence prevents an immediate decision, the competitor shall be allowed to compete under protest, and the protest shall be decided by the Games Committee within one week, unless its subject be the eligibility of the competitor to compete, in which case the Games Committee must report such protest within 48 hours to the Member Services Chair in the Association where the meet is held.
10. Where a Jury of Appeal has been established to consider appeals of decisions of the Referee as to matters which developed during the conduct of the event, appeals must be made in writing by an athlete, or by an official representative of an athlete, within 30 minutes of the official publication of the amended result of an event arising from the decision made by a Referee, or of the advice being given to those making the protest, where there is no amendment of any result. In the case of long distance races, the time period shall be 24 hours. For cross country, Masters Long Distance Running Championships and the Professional Section of road races the time shall be 30 minutes. Such person may only appeal if they are or have an athlete competing in the same round of the event to which the appeal relates or are competing in a competition on which a team points score is being conducted.

NOTE: *The relevant Referee shall, after making a decision on a protest, immediately inform the Competition Secretary of the time of the communication of the decision. If the Referee was unable to communicate the decision orally to the relevant teams/athletes, the official time of the publication will be that of posting of the amended result or of the decision at the Technical Information Center.*

RULE 147
MIXED COMPETITION

1. Universal competitions, such as relays, other team events in which men and women compete together or events in which men and women compete with a single set of results, are permitted in accordance with the published entry materials/Technical Information of the relevant body. A universal event shall have a single set of results.
2. Other than under Rule 147.1 for all other competitions held completely in the stadium, mixed events between male and female participants shall not normally be permitted. However, authorization for such mixed competition races of 5000 meters or longer may be made for a competition by the Chair or designee of the appropriate sport committee or council and shall always be granted for field events.

NOTE 1: *For Masters exception see Rule 320.8.*

NOTE 2: *In Race Walking events, Men and Women may start together on the same start line.*

3. Mixed Competitions in Track Events as permitted under this Rule shall be conducted only where there are insufficient competitors of one or both genders competing to justify the conduct of separate races. The gender of each competitor shall be shown in the result. Such races shall not, in any case, be conducted so as to allow competitors of one gender to be paced or assisted by competitors of another gender.
4. Field Events for men and women may be conducted simultaneously at one or more event sites. Separate result cards shall be used and results declared for each gender. Each round of trials of such events may be conducted either by calling all competitors of one gender followed by the other or by alternating genders. Where Vertical Jumps are conducted on a single event site, Rules 181 to 183 must be strictly applied including that the bar must continue to be raised in accordance with a single set of previously announced increments for the entire competition.
NOTE 1: *For the purposes of Rule 180.12, all competitors shall be regarded as if they were of the same gender.*
NOTE 2: *Trials of events in Rule 147.4 may be conducted in a format determined by the Games Committee to address the needs of the competition, such as one gender followed by the other or alternating genders.*

RULE 148
SURVEYING, MEASUREMENTS AND WEIGHTS

1. The accuracy of the markings and installations for athletics facilities as applicable under Rule 140, Rule 149.2, Rule 160, Rule 180 and Rule 187 shall be checked by an appropriately qualified surveyor who shall furnish appropriate certificates with any check measurements made to the relevant body and/or the facility owner or operator. The Surveyor shall be given full access to stadium plans and drawings and the latest measurement report for the purpose of this verification.
2. All measurements shall be made with a steel tape, fiberglass tape, bar graduated in centimeters, or an electronic measuring device. The accuracy of each, except the fiberglass tape, shall be verified through appropriate calibration or certification at all National Championships and is recommended for all competitions. For measurement device restrictions for a record, see Rule 264.2 and Rule 264.3.

3. (a) All measurements of field events must be read by the Field Judges or Electronic Measurement Judges. When measuring the distances of throwing events and horizontal jumps, the part of the tape recording the distance achieved must be held by the official at the circle or take-off point.
 - (b) Distances in field events:
 - i. Shall be measured in meters and shall always be recorded to the nearest 0.01 m below the distance measured if the distance measured is not a whole centimeter (i.e., fractions less than 0.01 m must be ignored).
 - ii. For methods of measurement specific to events, see Rule 181.2, Rule 184.8, and Rule 187.7. In the case of a record, see the procedures in Rule 264.
 - (c) Only legal attempts shall be measured, unless an immediate protest is made per Rule 146.7.
4. All implements used on the field of play shall be weighed on a governmentally approved scale, or a scale that has a known calibration and linearity, and measured to ensure they meet other specifications required herein. Implement certification devices shall be constructed such that the gauges are within acceptable tolerances to assure the legality of the implements for the specified competition. In the case of a record, the implement shall be impounded and re-measured prior to its continued use in the competition to assure it meets the specifications for a record.

NOTE 1: *It is advisable to have at least one and preferably two calibration weights which are traceable to government standards in order to routinely confirm calibration and linearity from 1 kg to 8 kg.*

NOTE 2: *For measurement of tracks, see Rule 160. For measurement and certification of road courses, see Rule 240.*

RULE 149 VALIDITY OF PERFORMANCE

1. No performance accomplished by an athlete shall be valid unless it has been made during a bona fide competition on a facility and (where relevant) using an implement that conforms to specifications set within these Rules. Performances used by an athlete for submission to World Athletics in order to obtain a world record, world ranking points or to qualify for a World Athletics competition shall be achieved on a facility and with implements that comply with World Athletics Rules.
2. Performances made outside traditional athletics facilities (such as those held in town squares, other sporting facilities, beaches, etc.) or on facilities temporarily built inside a stadium shall only be valid if all of the following conditions are met:
 - (a) Qualified officials are appointed to and officiate at the event;
 - (b) Where applicable, equipment and implements in conformity with the Rules are used;
 - (c) The event is conducted at a site or facility in conformity with the Rules, including a survey in accordance with Rule 148.1. When possible this shall occur on the day of the event;
 - (d) The relevant governing body has issued an appropriate permit for such an event; and

- (e) In the case of an oval track, its length is greater than 201.2 meters but no greater than 400 meters.
3. Performances in events conducted in a fully or partially covered facility, where the length or other specifications of the facility do not comply with the rules for indoor or Short Track competitions, shall be valid and recognized as if they were achieved outdoors if they are in compliance with the provisions of Rule 149.2. See Rule 211.1.
 4. Performances made in accordance with these Rules in Qualification Rounds, in deciding ties in High Jump and Pole vault, in any event or part of an event which is subsequently decreed void under the provisions of Rules 125.11, 146.5, 163.4 or 180.1, in Race Walking events in which Rule 230.3(j) is applied and the competitor is not disqualified or in individual events in a Combined Event competition, regardless of whether or not the athlete completes the whole Combined Event competition, will normally be regarded as valid for purposes such as statistics, records, rankings and the achievement of entry standards.

RULE 150 VIDEO RECORDING

An official video recording of all events to the satisfaction of the appropriate Sport Committees shall be made in competitions held under Rule 10 and Rule 11, and may be made in other competitions. The video recording should be sufficient to demonstrate the accuracy of performances and any violation of the Rules.

RULE 158 CORRECTABLE ERROR

Within 72 hours after the last event of a competition, or before a subsequent event round, results can be corrected by the Games Committee if an administrative error is detected, such as incorrect calculation of combined-event scores, placing or other errors based on clear and irrefutable factual evidence.

NOTE 1: *This Rule is intended to allow for correction of administrative mistakes, e.g. wrongful competitor identification, typographical and mathematical mistakes. It is not intended to extend the review period for judges and referees or to negate the established appeal process.*

NOTE 2: *For LDR exception see Rule 146.2(c).*

RULE 159 ELECTRONIC DEVICES

Electronic devices not approved by the Games Committee shall not be used by any individual in the area of competition or designated warm-up area.

NOTE: *The Games Committee may authorize use of personal communication devices for event operation.*

RULE 160 TRACK LANES AND MEASUREMENTS

1. In all outdoor races at distances up to and including 400 meters, wherever possible, each competitor shall have a separate lane with a width of 1.22m \pm 0.01m (4 ft.)

measured as provided in paragraphs 2 and 4 hereof and properly marked by lines 5cm in width. On tracks whose width does not permit 8 lanes of that width, the minimum width of the lanes may be 91.4cm (3 ft.). Only the line on the right hand side of each lane shall be included in the measurement of the width of each lane. The inside radius should be limited to between 35.00m and 38.00m unless the curve is a double bend track designed to fit a playing field on the infield. In that case the minimum bend radius is 24.00m.

2. All distances run or walked shall be determined on the basis of a hypothetical line 30cm outward from the inner edge of the track, except that for races upon straightaways, the distance shall be measured in a raised direct line from the starting mark to the finish line. For any track without a raised border on the curve, the measurement shall be made 20cm from the outer edge of the white line marking the border of the track. For events run in lanes around a turn, all lanes except the one on the inside border shall be measured 20cm outward from the inner lane line.

NOTE: *If a track with a removable curb is used without the curb in place for races longer than 10,000 meters, it must then be regarded as an uncurbed track according to Rules 160.2 and 160.3. In this case the distance, which would normally be measured 30cm from the curb, must be recalculated to a path 20cm from the line marking the inside border. Assuming that this line lies directly under the intended curb location, this reduces the measured distance by 0.63m per lap (for example, 400m would become 399.37m). This reduced distance must then be used for all calculations of the distance run.*

3. The nominal length of an outdoor track shall preferably be 400 meters. It shall consist of two straights and two turns. The inside of the track shall be bordered by a raised curb of suitable material approximately 5cm high and 5cm wide. The curb may be raised to permit surface water to drain away, in which case the maximum height shall be 6.5cm. The curb on the two straights may be omitted and a white line 5cm wide substituted. If a section of the curb on the curve has to be removed temporarily for field event competitors, its place shall be marked with a white line 5cm wide and by plastic cones or flags (minimum height 20cm) placed on the white line so that the edge of the base of the cone or flag pole coincides with the edge of the white line closest to the track, and placed at intervals not exceeding 4m. This shall also apply for the section of the steeplechase track where runners divert from the main track to negotiate the water jump, at intervals not exceeding 10m.
4. In races including at least one curve, the direction of the running or walking shall be left-hand inside, except that for track events longer than 100 miles or 12 hours, competitors may, at the discretion of the Race Director, be permitted to reverse direction around the track at regular intervals. Direction reversal shall be done around a fixed object (e.g., a traffic cone) and shall be done at either the official start line or the official finish line of the event, never at any other points on the track. Direction reversal shall be done only at regular time intervals (e.g., every 3 hours), not at fixed distance intervals. During direction reversal, runners who have reversed shall yield right-of-way to the inside lane to runners who have not yet reversed until the entire field of competitors has reversed direction. In all races run entirely on the straight, the direction of the race may be either left-hand or right-hand inside, according to the available conditions.
5. The maximum allowance for lateral inclination of the track should not exceed 1:100, with the inclination to the inside lane, unless an exemption from World Athletics

exists. The overall downward inclination in the running direction shall not exceed 1:1000.

6. The start of a race shall be indicated by a white line 5cm wide marked on the track or ground. In the case of events starting outside the stadium, the start line may be up to 30cm in width and may be of any color contrasting distinctively with the surface or the finish line. In all events, the start line and the finish line shall be so painted or laid down so that the distance of the race shall be measured from the edge of the start line farther from the finish line to the edge of the finish line nearer to the start line.
7. In all races around turns not run in lanes, the start line shall be curved so that wherever it occurs on the track, all runners start the same distance from the finish. The track shall be permanently marked to show the cut-in points in the 800 Meters and in relay races that start, but do not finish, in lanes.

NOTE: *The 1500m start line or any other curved start line may be extended out from the outside bend lane to the extent that the same synthetic surface is available.*

8. (a) The 200 Meters shall be run in lanes around one turn.
 - (b) The 400 Meters shall be run in lanes around two turns.
 - (c) Whenever possible, the 800 Meters shall be run in lanes until the athletes have passed the nearer edge of the break line at the end of the first turn. The starts shall be so staggered that the distance from the start to finish shall be the same for each competitor. Small markers, such as cones or prisms 5cm x 5cm and no more than 15cm high, preferably of a different color from the break line and lane lines, shall be placed on the lane lines immediately before the intersection of the lane lines and the break line.
9. The separate arced start line referred to in Rule 162.18 shall be marked in such a way that all of the competitors shall run the same distance. Also, an arced break line shall be marked at the beginning of the following straight to indicate to the athletes of the outer group where they are permitted to join the competitors using the regular start line. Small markers, as in Rule 160.8(c), shall be placed at intervals not exceeding 4m along the inside lane boundary of the outer group from their start to the break line.

NOTE: *Full technical information on track construction, layout and marking are contained in the World Athletics' Manual on Track and Field Facilities, which is available from World Athletics at www.worldathletics.org.*

RULE 161 STARTING BLOCKS

1. Starting blocks shall comply with the following general specifications:
 - (a) The starting blocks shall consist of two foot plates, against which the competitor's feet are pressed in the starting position and which shall be mounted on a frame. They shall be entirely rigid in construction and shall give no unfair advantage to the competitor. The frame shall in no way obstruct the competitor's feet as they leave the blocks.
 - (b) The foot plates shall be sloped to suit the starting position of the competitor, and may be flat or slightly concave. The surface of the foot plates shall accommodate the spikes in the competitor's shoes, either by using slots or recesses in the face

of the foot plate or by covering the surface of the foot plate with suitable material permitting the use of spiked shoes.

- (c) The mounting of the foot plates on a rigid frame may be adjustable, but it shall allow no movement during the actual start. In all cases, the foot plates shall be adjustable forward or backward in relation to each other. The adjustments shall be secured by firm clamps or a locking mechanism, which can be easily and quickly operated by the competitor.
 - (d) They shall be fixed to the track by a number of pins or spikes, arranged to cause the minimum possible damage to the track. The arrangement shall permit the starting blocks to be quickly and easily removed. The number, thickness and length of pins or spikes depend on the track construction. The anchorage shall permit no movement during the actual start.
 - (e) When a competitor uses his/her own starting blocks, the blocks shall comply with these Rules but otherwise may be of any design or construction, provided that the blocks do not interfere with other athletes and can be shown to cause no damage to the track
2. Starting blocks shall be used for all races up to and including 400 meters and the lead-off leg of relays where that leg does not exceed 400 meters. They shall not be used for any other race.
NOTE 1: *For Youth Athletics exception see Rule 302.2(e).*
NOTE 2: *For Masters exception see Rule 332.2(d).*
 3. No part of the starting block, including the frame, shall overlap the start line or extend into another lane with the exception that, provided there is no obstruction to any other competitor, the rear part of the frame may extend beyond the outer lane line.
 4. If the Starter deems it necessary, he/she may assign a block holder to any athlete. The block holder must sit on the track so that the holder does not interfere with the view of the Starter or Recall Starter(s). The holder shall not make contact with the foot pads.
 5. No competitor shall receive assistance in setting starting blocks except from an individual designated by the starter.
 6. Starting blocks linked to a World Athletics-approved start information system may be used at any competition and shall be used in Open Men's and Women's National Championships and USA Olympic Selection competition to assist the Starters. The system shall emit an acoustic signal, audible to the Starter, or assigned Recall Starter, whenever the reaction time of the athlete detected by the system is less than 0.100 second. In addition to the acoustic signal, a recall signal shall be an automated function of the start information system when such function is available. See Rule 162.14.

RULE 162 THE START

1. All questions concerning the start shall be decided by the Starter.

2. When starting, all competitors must be behind the start line and they must not touch the start line or the surface in front of it with any part of the body. Starting positions in events at all distances shall be numbered in order that the lowest number is closest to the inner edge of the track.

NOTE: *For this Rule, hair is not considered a body part.*

3. Prior to each running event, the Starter or designee shall give instructions to competitors concerning the commands to be used. Before any starting commands, the Starter shall ascertain that the applicable Timers, Finish Line Judges, Photo Finish Judges and the Wind Gauge Operator, are ready.
4. In races where the competitors are not placed behind the same start line (i.e., races of 200m to 800m on oval tracks), the Starter should use a microphone transmitting to speakers positioned at or near the start line in each lane relaying the commands and any start and recall signals to all competitors at the same time. Where such a device is not used, the Starter shall be so placed that the distance between the Starter and each of the competitors is approximately the same.
5. Except for time handicap races, all running and walking events shall be started by the sound of an approved starting device. The starting device shall accommodate the need to be clearly heard by all competitors, initiate any timing device used and provide a clear visual signal. See Rule 242.5.
 - (a) Where a pistol is used, it may be of any caliber, shall be with black powder shells giving a distinct flash/smoke and should be of suitable loudness (>110dB at 5 meters).
 - (b) When an electronic tone is used, the starting system (electronic device and speakers) shall be of suitable loudness (>110dB at 5 meters) and shall simultaneously activate a flash/strobe.
 - (c) In time handicap races, the start command "Go" may be used.
6. The commands of the Starter shall be:
 - a) In races not exceeding 400 meters, "on your marks" and "set."
 - b) In races exceeding 400 meters, "on your marks." Before the command "on your marks," the Starter may assemble the competitors at an actual or imaginary line between 1m and 3m behind the start line.

No later than the command "on your marks," the Starter shall raise the hand with the starting device. That hand shall remain extended above the head until the start signal has been generated. During that time, the hand without the starting device shall remain at the Starter's side.

NOTE 1: *The above may be modified to accommodate the hearing impaired.*

NOTE 2: *To facilitate hand timing, the Starter may signal the Timers just prior to the 'set' command.*

7. In races up to and including the 400 Meters and lead-off relay legs not exceeding 400 meters, a crouch start and starting block must be used, unless prohibited by a permanent physical disability. Each competitor must, after the "on your marks" command, assume a position completely within the assigned lane and behind the start line. Both hands and at least one knee must be in contact with the ground and both feet in contact with the foot plates of the starting block. At the "set" command, the

competitor shall immediately rise to a final starting position retaining the contact of the hands with the ground and of the feet with the foot plates of the starting block. After the Starter has ascertained that all competitors are “set,” the starting device shall be activated.

8. In races longer than 400 Meters, all starts shall be made from a standing position. Each competitor shall, after the “on your marks” command, assume a position behind the start line and, if applicable, completely within the assigned lane, without a starting block and shall not touch the ground with his/her hand or hands during the start. After the Starter has ascertained that all competitors are steady and in the correct starting position, the starting device shall be activated.
9. On the command “on your marks,” or “set” as the case may be, all competitors shall at once and without delay assume their full and final starting position.
10. The Starter shall not activate the starting device, or give the start command, while any competitor is in motion nor before the Starter has ascertained that each competitor is steady and in the correct starting position.
11. Should the Starter or any Recall Starter not be satisfied that all is ready to proceed after the competitors are on their marks, he/she shall cancel the start and order the competitors to “stand up.” Upon reassembly, a green card shall be shown to all the athletes if a violation was not committed by any athlete.
12. A competitor, after assuming a full and final set position, shall not commence his/her start until first receiving the sound of the starting device. Commencement of the start is defined:
 - (a) In races where starting blocks are used, as any motion by a competitor that includes or results in one or both hands losing contact with the ground or one or both feet losing contact with the foot plates of the starting blocks.

NOTE: *An athlete signaling to abort the start (see Rule 162.17a) is excluded from this definition.*
 - (b) In races where a standing start is used, as any motion resulting in one or both feet losing contact with the ground not attributable to ‘accidental overbalancing’.

If the Starter determines that prior to receiving the sound of the starting device, a competitor commences, as above, or initiated a movement prior to receiving the sound of the starting device that was not stopped and continues into a commencement of the start, it shall be a false start.

NOTE 1: *An athlete must react to the start signal, not anticipate it; therefore, any start where the Start Information System detects movement before the expiration of the limit established in Rule 161.6 or Rule 162.14 shall be recalled, and an assessment made regarding ‘commencement of the start’.*

NOTE 2: *‘Continues into a commencement’ does not require lost contact with the ground by one or both hands or lost contact with the foot plates of the starting blocks by one or both feet before the sound of the starting device.*

NOTE 3: *Any other motion by a competitor, including that which is stopped before the start signal, shall not be considered commencement of a start. Such instances may, if applicable, be subject to a disciplinary warning or disqualification. See Rule 162.17.*

NOTE 4: *Competitors who start races in a standing position are more prone to overbalance. If such a movement is considered to be accidental, the start should be regarded 'unsteady' and Rule 162.11 should be applied. If a competitor is pushed or jostled over the line before the start, that competitor should not be penalized, and any competitor causing such interference may be subject to a disciplinary warning or disqualification. See Rule 162.17.*

13. All instances not satisfying Rule 129.2 shall be recalled. A violation of Rule 162.12 is not required.
14. When a World Athletics approved start information system is in operation (see Rule 161.6), the Starter and/or an assigned Recall Starter with no other duties shall wear headphones in order to clearly hear the acoustic signal emitted when the apparatus indicates a possible false start; i.e., when reaction time is less than 0.100 seconds. As soon as the Starter and/or an assigned Recall Starter hear the acoustic signal, and if a start signal was given, there shall be a recall. After conferring with the Recall Starters, the Starter shall examine all the available numerical and graphical information generated by the start information system in order to confirm which athlete(s), if any, is/are responsible without any apparent malfunction for the apparatus emitting a signal. The evidence from this equipment shall be used as a resource by the relevant officials to make a decision. See Rule 125.3.
15. Any competitor(s) charged with a false start shall be disqualified and a red and black (diagonally halved) card shall be raised in front of the respective competitor(s), and when lane markers are being used, a corresponding indication should be placed on the respective lane marker(s). For Combined Events, see Rule 200.3(c); For Youth, see Rule 302.2(d); For Masters, see Rule 332.2(c).
NOTE: *In practice, when one or more athletes commit a false start, others are inclined to follow and, strictly speaking, any athlete who does so has also committed a false start. The Starter should warn or disqualify only such athlete or athletes who, in the Starter's opinion, was/were responsible for the false start. This may result in more than one athlete being warned or disqualified. If the recalled or aborted start is not due to any athlete (e.g. a false start caused by external noise), no warnings shall be given and a green card shall be shown to all the athletes. See Rule 162.17 Note.*
16. The Starter or any Recall Starter, after the start signal, who is of the opinion that the start was not fair, or who hears the false start acoustic signal generated by a start information system, see Rule 161.6 and Rule 162.14, shall recall the competitors by again activating the starting device or sounding a distinctive recall tone.
NOTE: *Except for Rule 242.5, a recall, for a fall by a competitor, shall occur only when the opinion of a member of the start team is such that the fall is wholly part of an "unfair start". Any incident resulting in a recall for an "unfair start" must have taken place within close proximity to the start line and be clearly associated with the start. A distance beyond 10 meters shall not be considered "close proximity" to the start line.*
17. The Starter or any Recall Starter shall abort the start, and report to the Referee for improper conduct or for acting in an unsporting manner, an athlete who:
- after the command "on your marks" or "set" as appropriate, and before the sound of the starting device, signals to abort the start by an action such as raising a hand or standing from a crouched position and does not provide a valid reason for such action; or

- (b) in their judgment, fails to comply with the provisions of the command “on your marks” or “set” as appropriate, does not attain a full and final starting position at once and without delay, or requires a warning on any provision of Rule 162; or
- (c) in their judgment, after the command “on your marks” or “set”, disturbs another competitor in the race through sound, movement or otherwise, regardless of whether it results in such competitor(s) committing what would otherwise be a false start; or
- (d) has repeated movement resulting in multiple aborted starts, even if it does not result in another competitor committing what would otherwise be a false start; or
- (e) in their judgment, performs any other misconduct at the start.

In these cases, the Referee shall act in accordance with Rule 125.9 and/or Rule 145.2, warning or disqualifying (in case of a second infringement of the Rule during the same competition) upon validation of the report. When an extraneous reason was determined the cause for aborting the start or the Referee does not agree with the Starter’s decision, a green card shall be shown to all the athletes to indicate that no violation was committed by any athlete.

NOTE: *Alternate visual or audial indication may also be approved, such as the use of widescreens or dedicated monitors, communication via speakers, use of light towers or similar devices, etc. The procedure shall first be coordinated between the Technical Delegate(s), the Start Referee and the Event Presentation Manager, and the broadcaster should be informed.*

- 18. In races with more than 12 competitors that do not start in lanes, competitors may be divided into two groups with one group of approximately two-thirds of the competitors on the regular arced start line and the other group on a separate arced start line marked across the outer half of the track. The outer group shall run as far as the end of the first turn on the outer half of the track. See Rule 160.9.
- 19. In handicap races, the Starter shall disqualify from that event any competitor who attempts to advance from his/her mark, as prescribed in the official program, after the Starter has given the final oral command.

RULE 163 RUNNING COMPETITION

- 1. Competitors shall be placed at the finish in the order in which any part of their bodies (i.e., the “torso,” as distinguished from the head, neck, arms, hands, legs, or feet) reaches the finish line. In non-championship races conducted partly or entirely outside the stadium, the Games Committee may elect to place competitors using ‘net time order’, ‘first-across the line’ or a combination of both to determine placing and awards. See Rule 165.16.
- 2. In running events, except as stated in Rule 170.5, no competitor may place any mark or marker upon the running surface or alongside it for his/her assistance. The Umpires shall direct the relevant competitor to adapt or remove any marks or objects not complying with this Rule. If they do not, the Umpires shall remove the marks or objects.

3. Each competitor shall run in a direct line after entering the final straightaway in all races of two or more turns unless there is another competitor in his/her path.
4. Any competitor or participant responsible for jostling, running across, or obstructing another competitor or participant so as to impede his/her progress shall be liable to disqualification in that event. The Referee shall have the authority to order the race be re-held, excluding any disqualified competitor(s), for one, some or all competitors seriously affected by jostling or obstruction or allow such competitors to compete in a subsequent round of the race. Normally, such competitor(s) should have completed the event with bona fide effort. The Referee shall also have the authority to order the race be re-held or advance one, some or all competitors seriously affected by jostling or obstruction that is unintentional or caused otherwise than by a competitor if it is just and reasonable to do so.

NOTE 1: *Some factors to be considered when determining a disqualification include safety, equitable competition, severity of the infraction and resulting consequence.*

NOTE 2: *Jostling should be understood as physical contact on one or more occasions with another competitor(s) that results in an unfair advantage or causes injury or harm to those competitors, or consequently, to another athlete(s).*

5. Each competitor must keep in the lanes outside the line or curb marking the inside of the track, including the curved part of the diversion from the track for the Steeplechase water jump. In races run entirely in lanes, each competitor must keep in the allotted lane from start to finish. In races run partially in lanes, each competitor must keep in the allotted lane from the start to the marked cut-in points. Unless a material advantage has been gained or the athlete is in violation of Rule 163.4, a competitor shall not be disqualified if he or she:
 - (a) Is pushed or forced by another competitor or object to step out of the lane, or
 - (b) Steps, runs or makes contact out of the lane on the straightaway, or
 - (c) Steps or runs outside of the outer lane line on the curve, or on any straight part of the diversion from the track for the Steeplechase water jump; or
 - (d) In all races run in lanes, touches once the line on their left or the curb or line marking the border of the inside of the track on a bend, or
 - (e) In all races (or any part of races) not run in lanes, steps once on or completely over the curb or line marking the applicable inside border on a bend.

Excluding the above exceptions, the Referee shall disqualify a competitor if material advantage is gained.

NOTE 1: *Material advantage includes improving position by any means, including exiting from a 'boxed' position in the race by having stepped or run inside the inside edge of the track.*

NOTE 2: *Where a race is started in lanes and then continues not using separate lanes, this Rule applies accordingly in each such part of the race.*

- (f) In races with multiple rounds, the infringement defined in Rule 163.5(d) or Rule 163.5(e) may be made only once during all rounds of an event by a particular competitor without disqualification of the competitor. A second infringement shall result in the disqualification of that competitor whether it was made in the same round or in another round of the same event.

NOTE 3: For Youth Athletics, violations are only determined within each round of an event.

- (g) In the case of Relay Races, any second step by a competitor who is a member of a team, regardless of whether committed by the same or different competitor, shall result in the disqualification of the team whether it happened in the same round or in different rounds of the same event.

NOTE 4: All lane infringements should be tracked in the competition data systems and shown on the start lists and results. See Rule 132.4 for the symbol to be used. The carry-forward rule applies throughout all rounds of a given running event, including relays, not to a different running event. In the Combined Event, an athlete should only be disqualified for more than one infringement, if it occurs during the same race. There is no carry-forward of the infringement to subsequent races within that Combined Event.

6. Leaving Track or Course:

- (a) No competitor, after voluntarily leaving the track or course, except in compliance with Rule 170.16, shall be allowed to rejoin a race either for the purpose of gaining a place or to pace or to assist another competitor. The competitor shall be recorded as not finishing the event. A competitor attempting to re-enter the race shall be disqualified.
- (b) In any track event of 20,000 meters or more or in any road race, a competitor may leave the marked course with the permission and under the control of a judge or other authorized official, provided that by going off or returning to the course the athlete does not lessen the distance to be covered.

7. To be considered a finisher, a competitor must complete the race.

8. In any race decided on the basis of the distance covered in a fixed period of time, the Starter shall activate the starting device or give other audible or visual signal exactly one minute before the end of the race to warn competitors and judges that the race is nearing its end. At the exact specified time after the start, as directed by the Chief Timer, the Starter shall signal the end of the race by again activating the starting device or giving other audible or visual signal. The Timers will then immediately stop their watches. At the instant of the signal of the expiration of the time, the Judges appointed for that purpose shall mark the exact spot where each competitor last touched the track before or simultaneously with the final signal. Competitors may be given marking devices to place at their last contact point to aid the Judges. The distance achieved shall be measured to the nearest meter or yard behind the rear edge of the last footprint of the competitor. At least one judge shall be assigned to each competitor before the start of the race for the purpose of recording the time of each lap completed and marking the distance achieved.

9. Distances achieved in fixed time period races may be measured in miles, yards, or meters. However, the results must be reported in kilometers and/or meters. Distances converted from other than metric measurement must be indicated as such. Any conversions shall always be rounded down to the next lower meter.

10. With the exception of performances made in an enclosed and covered facility, the following shall apply:
- (a) The periods for which the wind will be measured, from the flash of the starting device, are as follows:

80 Meter Hurdles.....	10 seconds
100 Meters.....	10 seconds
100 Meter or 110 Meter Hurdles	13 seconds

- (b) In the 200 Meters and 200 Meter Hurdles run around a curve, except for races on a Short Track, the wind velocity shall be measured for a period of 10 seconds, commencing when the runners enter the straightaway. In the Long Jump and Triple Jump, the wind velocity shall be measured for a period of 5 seconds, commencing 40m from the take-off board in the case of the Long Jump and 35m from the take-off board in the case of the Triple Jump or, if the competitor runs less than 40 or 35m, as the case may be, from the start of the run.
11. The wind measuring instrument shall be placed beside the sprint track, adjacent to lane 1, preferably 50m from the finish line and, for the Long Jump and Triple Jump, 20m from the take-off board. The instrument shall be not more than 2m away from the track or straightaway and should be approximately 1.22m (4 ft.) above the competition surface.
NOTE: *When multiple boards are used, the 20m distance is from the board furthest from the pit.*
 12. The wind gauge shall be read in meters per second, rounded and recorded to the next higher tenth of a meter per second, in the positive direction. (i.e., a reading of +2.03m per second shall be recorded as +2.1; a reading of -2.03m per second shall be recorded as -2.0). Gauges that produce digital readings expressed in tenths of meters per second shall be constructed so as to comply with this rule.
NOTE: *For record requirements, See Rule 262.4.*
 13. To ensure an accurate reading of only the wind component in the direction of running, a mechanical wind gauge should have some type of protection which reduces the impact of any crosswind component. Where tubes are used, their length on either side of the measuring device should be at least twice the diameter of the tube.
 14. The wind gauge may be started and stopped automatically and/or remotely, and the information conveyed directly to the competition computer.
 15. Intermediate times and preliminary winning times may be officially announced and/or displayed. Otherwise such times must not be communicated to the athletes by persons in the competition area without the prior approval of the Referee. This permission shall only be given when there are no time displays visible to athletes at the relevant point and in circumstances where such times will be provided to all athletes in the race.

RULE 164 THE FINISH LINE

1. The finish line shall be a line drawn across the track or course surface from finish post to finish post. Where their use may interfere with Photo Finish equipment, finish posts should not be used.
2. For the purpose of aiding the judges, but not as a finish line, there can be stretched across the track at the finish, 1.22m (4 ft.) above the ground and directly over the finish line, a worsted string or thread or tape of material which will not tend to injure the runners when broken by them. This worsted string or finish tape shall be held by

officials other than the judges or by releasing clamps fastened to the finish post on either side, so that it will always be at right angles to the course and parallel to the ground. It is recommended that where there is Photo Finish, the worsted string or tape not be used.

3. The finish post shall be of rigid construction, 1.37m (about 4 ft. 6 in.) in height, 7cm in width - and by width is meant the direction at right angles with the track - and 2cm in thickness.
4. The finish line on the surface, while theoretically of no appreciable width must actually have some width so that it may be more readily observed. The finish line shall be 5cm to 30cm in width and shall be of any solid color contrasting distinctively with the surface of the finish area.
NOTE: *See Rule 244 for finish line requirements at road events. See Rule 251 for finish line requirements at cross country, mountain and trail events.*
5. In order to confirm that the camera is correctly aligned and to facilitate the reading of the Photo Finish image, the intersection of the lane lines and the finish line shall be colored black in a suitable design. Any such design must be solely confined to the intersection, for no more than 2cm beyond, and not extended before, the nearer edge of the finish line. Black marks 5cm by 2cm may also be placed on each side of the intersection of the middle lane and the finish line.

RULE 165 TIMING

1. Four methods of timing are official, hand timing, Photo Finish, video timing, and Transponder Timing as set forth in this Rule.
NOTE: *For LDR/Road Event requirements see Rule 244.*
2. A Photo Finish system should be used. The times from such a system, governed by paragraphs 9 through 12, shall be the official times unless the Referee determines that the equipment is not operating properly.
3. When hand times must be used, timing procedures shall be governed by sections 5 through 8.
4. The time shall be taken from the flash/smoke of the pistol or approved apparatus to the moment at which any part of the competitor's body (i.e., the "torso," as distinguished from the head, neck, arms, hands, legs, or feet) reaches the perpendicular plane of the nearer edge of the finish line.
 - (a) For large races conducted partially or completely outside the stadium, false starts are not recalled and the time is taken from the first moment a competitor crosses the start line if that is before the starting signal.
 - (b) In non-championship races conducted partly or entirely outside the stadium, the Games Committee may elect to use 'net times', 'gun times' or a combination of both to determine official times. See Rule 165.16.
 - (c) A system which operates automatically at the finish, but not at the start, shall be considered to produce hand times provided that the system was started in accordance with Rule 165.4 or with equivalent accuracy.

- (d) A system which operates automatically at the start but not at the finish shall be considered to produce neither hand nor Photo Finish times and shall not therefore be used to obtain official times.

Hand Timing

5. Hand times shall be taken by manually operated electronic devices with digital readouts. If the Photo Finish system was not automatically started with the starting device, or suffered a loss of operation during the race, but did accurately record the finish, the hand times should be adjusted using information from a Photo Finish system, if such information is available.
6. If two of the Official Timers' watches agree and the third disagrees, the time shown by the two shall be the official time. If all three watches disagree, the time shown by the watch recording the middle time (not the average of all three) shall be the official time. If for any reason only two watches record the time of an event, and they fail to agree, the longer time of the two shall be accepted as the official time.
7. (a) For all hand-timed races on the track, unless the time is an exact 0.1 second, the time shall be converted and recorded to the next longer 0.1 second, e.g., 10.11 shall be recorded as 10.2. For races partly or entirely outside the stadium, unless the time is an exact whole second, the time shall be converted and recorded to the next longer whole second, e.g., 2:09:44.3 shall be recorded as 2:09:45.
- (b) When the time displayed on electronic, manually operated digital timers includes decimal place values greater than zero, the recorded time shall be the displayed time rounded up to comply with the provisions of 7(a), above. E.g., For the track, a displayed time of 1:45.209 shall be recorded as 1:45.3 and a displayed time of 47.31 shall be recorded as 47.4. For outside the stadium, a displayed time of 2:09:44.001 or 2:09:44.01 shall be recorded as 2:09:45, a displayed time of 31:00.00 is rounded to and recorded as 31:00 and a displayed time of 31:00.01 is rounded to and recorded as 31:01.

NOTE: *Times for races conducted partly or entirely outside the stadium may be published to 0.1 second to illustrate time differences between finishers, but only times rounded to the next longer full second shall be official. For the Road Mile, the conversion shall be done to the next longer 0.1 second.*

8. When possible, Timers shall be placed at least 5m back from and in line with the finish on an elevated platform.

Photo Finish

9. (a) If possible, there should be at least two Photo Finish (FAT) systems of a similar make in operation, one from each side of the track at the finish line. At the Open and U20 National Championships, at least two FAT systems of a similar type shall be used and the placement should be with at least one at each side of the track at the finish line. Preferably, the two FAT systems should be technically fully separated, i.e., supported by different power systems and recording and relaying the sound of the Starter's approved starting apparatus, by separate equipment and cables.
- (b) Where two or more FAT systems are used, one should be designated as the official one before the start of the competition. The times and places from the other system(s) or camera(s) should not be considered unless there is reason to doubt

the accuracy of the official system or if there is a need to use the supplementary images to resolve uncertainties in the finishing order or times.

- (c) In the event that all FAT systems malfunction at the start of a race, the race should be recalled. See Rule 129.
10. (a) The FAT system must be tested and certified to be accurate within four years of the competition.
- (b) The FAT system shall record the finish through a camera positioned in the extension of the finish line producing a composite image. In each following case, the image must be synchronized with a uniformly marked time scale graduated in 0.01 seconds.
 - i. For competitions defined in Rule 10.1 and Rule 11.1, this composite image must be composed of at least 1000 images per second.
 - ii. For other competitions, this composite image must be composed of at least 100 images per second.
 - (c) The system shall be started automatically by the Starter's signal, so that the overall delay between the report from the muzzle, or its equivalent visual indication and the start of the timing system is constant and equal to or less than 0.001 seconds.
 - (d) If the FAT system is not started automatically in accordance with this rule, the image shall so indicate automatically. In such case, the times recorded on the image will not, under any circumstances, per Rule 165.1, be considered official. The image may, however, be used as a valid support to determine positions and to adjust time intervals between runners. See Rule 165.5.
 - (e) The placing of the athletes shall be identified from the image by means of a cursor with its reading line guaranteed to be perpendicular to the time scale.
 - (f) The system must automatically determine and record the finish times of the athletes and must be able to produce a printed image which shows the time of every athlete.
11. Recording Times:
- (a) Photo Finish for races on the track up to and including 10,000 meters shall be read to 0.001 of a second, when possible. When the last digit is zero, that digit shall be dropped and the official time recorded in hundredths of seconds. Otherwise, the time shall be rounded to the next longer hundredth of a second and so recorded. When the Photo Finish device cannot be read to 0.001 of a second, it shall be read and recorded in hundredths of seconds, rounded up to the next longer hundredth when the time is between hundredths indicators.
 - (b) The result for Photo Finish timed races on the track longer than 10,000 meters shall be read in 0.01 of a second and shall be converted to the next longer 0.1 of a second and recorded in tenths of a second, e.g., for the 20,000 Meters Run, 59:26.32 shall be recorded as 59:26.4.

- (c) The times for races conducted partly or entirely outside the stadium (off the track) shall be read in 0.01 of a second and shall be converted to the next longer whole second, i.e., for the Marathon, 2:09:44.32 shall be recorded as 2:09:45.

NOTE: *For the Road Mile, when timed using FAT, the conversion shall be to the next longer 0.01 second.*

- 12. Any adjustments to hand timing will be accomplished by using time interval information from the Photo Finish system and will be recorded in accordance with Rule 165.7(a).

Video Timing

- 13. A videotape-based system may be used for non-championship competition, provided:

- (a) It complies with the provisions of Rule 165.10;
- (b) It uses a videotape camera aligned with the finish line and videotape that produces at least 50 frames per second; and
- (c) It incorporates a timing device that generates a reading to 1/100th of a second. When a frame-by-frame videotape-based system is used, the official time for each competitor shall be read from the time of the frame where the competitor is positioned exactly at, or immediately after, the finish line.

NOTE: *Video timing is not Photo Finish and is intended to be used as a backup timing system.*

- 14. When a videotape-based system is used, the Photo Finish Judges shall consider the frames immediately before and after the finish line. If there is any change in position between these two frames, the Judges shall declare a dead heat between the runners whose positions have changed.

Transponder Timing

- 15. The use of Transponder Timing systems in race walking events not held entirely within a stadium, road, and cross country races is permitted provided that:

- (a) The system requires no action by the runner during the competition, at the finish line, or during any finish line or results related system or process;
- (b) The weight of the transponder and its housing carried on the runners' uniform, race number or shoe is not significant;
- (c) None of the equipment used at the start, along the course or at the finish line constitutes a significant obstacle or barrier to the progress of the runner;
- (d) The transponder reading devices are set up to ensure that times are not recorded after the start line or before the finish line;
- (e) The system, including the implementation of its components and its technical specifications, is approved by the finish line subcommittee of the Road Running Technical Council;
- (f) The system is started in accordance with Rule 165.4;
- (g) The determination of the official finishing times and finishing order is in accordance with Rule 165.4 when necessary; and

NOTE: *See Rule 165.11(c) for recording of finishing times.*

(h) Times for other competitors will be adjusted, based on the official winning time.

(i) Appropriate back-up systems should be put in place.

16. In Masters LDR championships and in LDR non-championship races conducted partly or entirely outside the stadium, the Games Committee may elect to determine times, places and awards based on ‘net times’, ‘gun times’ or a combination of both provided that:

(a) The basis for determining times and places and awarding prizes and trophies is clearly stated in the entry materials/Technical Information and any listings of prizes and trophies to be awarded.

(b) To determine “net time” and place:

i. A net time for each competitor is calculated as the difference between the raw (un-rounded) times recorded by Transponder Timing systems at the start and finish.

ii. The official places of the competitors are determined by ranking them by net time. If two or more athletes have the same net time, they are tied.

iii. The official times are determined by rounding up the net times to the next full second. See Rule 165.11(c).

iv. In the event that no start and/or finish time is recorded for one or more competitors, the Referee shall determine the official places and times for the competitors affected based on all available evidence.

(c) In the event a record is claimed, the ‘gun time’ (the time from the flash of the approved starting device to the Transponder Timing at the finish) shall be submitted, except in the case of Masters records. See Rule 265.8.

NOTE: *For Masters LDR exception see Rule 341.10.*

SECTION II TRACK EVENTS

RULE 166 REGULATIONS FOR FORMING HEATS

1. Qualification rounds shall be held in track events in which the number of competitors is too large to allow the competition to be conducted satisfactorily in a single round (final). Where qualification rounds are held, all competitors must compete in, and qualify through, all such rounds except that the body having the control over a competition may, for one or more events, authorize the conduct of additional qualification round(s) either at the same or at one or more earlier competitions to determine some or all of the competitors who shall be entitled to participate and in which round of the competition. Such procedure and any other means (such as achieving entry standards during a specified period, by specified placing in a designated competition or by specified rankings) by which an athlete is entitled to participate, and in which round of the competition, shall be set out in the entry material/Technical Information for each competition.

NOTE 1: *In non-championship competitions, competitors may be seeded, ranked and/or allocated to lanes according to the procedure published in the entry material for the competition or by any other method determined by the Games Committee, preferably by notification to the competitors and their representatives in advance.*

NOTE 2: *Additional qualification round(s) may include preliminary qualification round(s) and / or Repechage Round(s).*

2. The published entry material/Technical Information for Rule 10, Rule 11, Rule 27, other selection competitions and all other meets to the extent feasible should include tables which shall, in the absence of extraordinary circumstances, be used to determine the number of rounds, the number of heats in each round and the qualification procedure, i.e. those to advance by place (P) and time (T), for each round. Such information shall also be provided for any additional qualification round(s). The published tables shall be formed according to the applicable provisions of Rule 166.2(a) through Rule 166.2(h) in the absence of other published entry material/Technical Information:

NOTE: *Meet Management may divert from the use of the tables below if it is considered appropriate to provide more content to the event or better competition conditions to the competitors.*

- (a) In individual races up to and including the 800 Meters, and relays up to and including the 4x400 Meters, the number of competitors on the track in a race, at the start, shall not exceed the number of lanes on the track for that event, excluding all lanes which would not qualify for record purposes. As an exception, in the first round for competitions listed in Rule 10 and Rule 27, or in any round for other competitions, up to 12 runners may start the 800 Meters. The 800 meters may be run using a group start and / or an arced start line for competitions other than those listed in Rule 10 or Rule 27.
- (b) In all rounds before the final (qualification rounds), where practical, at least the first and second place in each heat shall qualify for the next round and it is recommended that at least three in each heat shall qualify. Except where Rule 167 applies, other athletes may qualify by place or by time according to this Rule. When athletes are qualified according to times, only one system of timing shall be applied.

- (c) In events of 1500 meters or longer, the Games Committee shall determine the number of heats, the number of qualifiers and the basis for qualification, within the following guidelines.
- i. At least one half of the qualifiers for a succeeding round in any event shall be on the basis of place; no more than one half on the basis of time.
NOTE: *It is recommended that only a small number of competitors qualify by time.*
 - ii. If more than 16 report for the 1500 Meters, more than 18 report for the 3000 Meters or Steeplechase, or more than 20 report for the 5000 Meters (except for the Open Women's 5000 meters), heats shall be run.
 - iii. If heats are run as required in this section, then there shall be no more than 12 in the final of the 1500 Meters, no more than 14 in the final of the 3000 Meters or Steeplechase, and no more than 16 in the final of the 5000 Meters.
 - iv. If more than 24 report for the 10,000 Meters or the Open Women's 5000 Meters, the event should be run in sections of no more than 24, but may be run as heats of no more than 24, with no more than 20 advancing to the final of the 10,000 Meters and no more than 16 advancing to the final of the 5000 Meters.
 - v. The Games Committee of all meets other than the Open National Championship may elect to run these events as sections because of facility or scheduling conditions. The election of this format must be stated in the entry form.
- (d) When heats are being arranged, it is recommended that as much information as possible about the performances of all competitors be considered and the heats drawn so that, normally, the best performers reach the final. The following shall be the default principles used by the Games Committee for forming heats.
- i. First round seeding, including sections, is derived from the ranked list of declared athletes, arranged in order of qualifying times. For qualifying periods that span more than 12 months, marks prior to the current calendar year (or current season in the case of indoor meets) shall be ranked following the ranking of all other marks. Entrants who have no seed mark shall be listed randomly following all those who have a qualifying seed mark.
 - ii. In rounds other than the first:
 - a. For events up to and including the 400 Meters and relays up to and including the 4x400 Meters, seeding is determined from a list of competitors who advance on place followed by those who advance on time. Those who advanced on place are ranked first by their place in the previous round and then by their time in that round, creating ranked groups of place winners. Those who advance solely on time are ranked separately by only their time in the previous round. Only one system of timing may be applied to determine a qualifying position based on the time element. The disregarding of automatic timing for qualifying purposes does not negate those automatic times as official times for other purposes.
 - b. For all other events, seeding is from the list of competitors in the event, ranked by their original times used for seeding modified only by improvements achieved in previous rounds.

- iii. Athletes are assigned to heats, from the ranked list for the appropriate round, working alternately from left to right and right to left, in a zigzag fashion. If this assignment to heats creates a heat that contains the fastest times from each place group (fastest first, fastest second, fastest third, etc.), the same ranked list and zigzag fashion are used, but the heat assignment for the fastest time in each place group is alternated. (See example for 4 heats, 4 qualifiers, in the table below.)
- iv. In the process of assigning athletes to heats, no consideration shall be given to the team affiliation of any runner.
- v. If all heats do not have the same number of contestants, the heats for the extra athletes will be drawn by lot.
- vi. Heat order is drawn by lot.

NOTE: *The Games Committee may establish alternate Regulations for Forming Heats. These Regulations shall be in the Technical Information published, distributed and in the TIC (Rule 132.6) for the competition.*

(e) Examples of forming heats:

- Legend: 1a - Fastest First-Place Runner
 1b - Second Fastest First-Place Runner, etc.
 2a - Fastest Second-Place Runner
 2b - Second Fastest Second-Place Runner, etc.
 (concluding with)
 5a - Fastest Time Qualifier
 5b - Second Fastest Time Qualifier, etc.

3 Heats, 4 Qualifiers on Place, 4 on Time			4 Heats, 4 Qualifiers on Place			5 Heats, 3 Qualifiers on Place	
Heat 1	Heat 2		Heat 1	Heat 2		Heat 1	Heat 2
1a	1b		1a	1b		1a	1b
2a	1c		1d	1c		1d	1c
2b	2c		2b	2a		1e	2a
3b	3a		2c	2d		2c	2b
3c	4a		3a	3b		2d	2e
4c	4b		3d	3c		3b	3a
5a	5b		4b	4a		3c	3d
5d	5c		4c	4d		3e (draw heat by lot)	

NOTE: *To achieve 'the best performers reach the final' in Rule 166.2(d), note the modified zig-zag in 4 Heats, 4 on Place example.*

(f) Principles of assigning lanes.

- i. For events up to and including the 800 Meters and relays up to and including the 4x400 Meters:
 - a. In the first round, including a final if it is the first round and any additional qualification round, lanes will be drawn by lot, using the lanes designated by the Games Committee, unless the meet information provides otherwise.

- b. For all other rounds, competitors shall be ranked after each round in accordance with the procedures set forth in Rule 166.2(d)ii. For eight lanes of competition, three draws by lot, as follows, will then be made.

(1) For straight races with 8 lanes:

The first draw is for the four highest ranked athletes or teams to determine placing in lanes 3, 4, 5 and 6; The second draw is for the fifth and sixth ranked athletes or teams to determine placing in lanes 2 and 7; The third draw is for the two lowest ranked athletes or teams to determine placing in lanes 1 and 8.

(2) For 200m and 300m races with 8 lanes:

The first draw is for the three highest ranked athletes or teams to determine placing in lanes 5, 6 and 7; The second draw is for the fourth, fifth and sixth ranked athletes or teams to determine placing in lanes 3, 4 and 8; The third draw is for the two lowest ranked athletes or teams to determine placing in lanes 1 and 2.

(3) For 400m races, all relays up to and including 4x400m and 800m races started in lanes with 8 lanes:

The first draw is for the four highest ranked athletes or teams to determine placings in lanes 4, 5, 6 and 7; The second draw is for the fifth and sixth ranked athletes or teams to determine placings in lanes 3 and 8; The third draw is for the two lowest ranked athletes or teams to determine placings in lanes 1 and 2.

(4) For straight races with 9 lanes:

The first draw is for the three highest ranked athletes or teams to determine placing in lanes 4, 5 and 6; The second draw is for the fourth and fifth ranked athletes or teams to determine pacing in lanes 3 and 7; The third draw is for the sixth and seventh ranked athletes or teams to determine placing in lanes 2 and 8; The fourth draw is for the two lowest ranked athletes or teams to determine placing in lanes 1 and 9.

(5) For 200m and 300m race with 9 lanes:

The first draw is for the four highest ranked athletes or teams to determine placing in lanes 5, 6, 7 and 8; The second draw is for the fifth sixth and seventh ranked athletes or teams to determine placing in lanes 3, 4 and 9; The third draw is for the two lowest ranked athletes or teams to determine placing in lanes 1 and 2.

(6) For 400m races, all relays up to and including 4x400m and 800m races started in lanes with 9 lanes:

The first draw is for the three highest ranked athletes or teams to determine placings in lanes 5, 6 and 7; The second draw is for the fourth and fifth ranked athletes or teams to determine placings in lanes 4 and 8; The third draw is for the sixth and seventh ranked athletes or teams to determine placing in lanes 3 and 9. The fourth draw is for the two lowest ranked athletes or teams to determine placings in lanes 1 and 2.

NOTE 1: *The 800 Meter event may be run with one or two athletes in each lane or as a group start behind an arced line. This should normally be applied only in the first round unless, because of ties or advancement by the Referee or the Jury of Appeal, there are more athletes in a race of a subsequent round than were anticipated. The decision for the start-line configuration rests with the Games Committee for the first round and with the appropriate Referee thereafter. The procedure may be applied to any event situation where there are more athletes than lanes available. For Youth Athletics exception see Rule 303.1(c).*

NOTE 2: *When there are more lanes than athletes, the inside lane(s) should always remain free. For Youth Athletics exception see Rule 302.2(j).*

- ii. For track events with non-lane starts, the position of the athletes on the track will be drawn by lot in all rounds.
- (g) The principles set forth in forming heats and assigning lanes shall be applied to events when the number of entries requires more than one line of competitors at the starting mark.
- (h) On an eight or nine lane track, in the absence of extraordinary circumstances or tables published and distributed not later than the start of any declaration period, the following table shall be used in determining the number of heats and advancement procedure for events run entirely or partially in lanes. On other tracks, the table should be modified to reflect the other provisions of this Rule. For Youth Athletics exception see Rule 303.1(i). For Masters exception see Rule 332.2(j).

WHERE HAND TIMING IS USED

FOR EIGHT LANES					
Declared Entries	Trial Heats	Qualifying to Semi-Final	Semi-Finals Heats	Qualifying to Final	Final
1 to 8	0	-	0	-	1 to 8
9 to 16	0	-	2	3 + next 2 best times	8
17 to 24	0	-	3	2 + next 2 best times	8
25 to 32	4	3 + next 4 best times	2	3 + next 2 best times	8
33 to 40	5	4 + next 4 best times	3	2 + next 2 best times	8
41 to 48	6	3 + next 6 best times	3	2 + next 2 best times	8

FOR NINE LANES					
Declared Entries	Trial Heats	Qualifying to Semi-Final	Semi-Finals Heats	Qualifying to Final	Final
1 to 9	0	-	0	-	1 to 9
10 to 18	0	-	2	4	8
19 to 27	0	-	3	3	9
28 to 36	4	4	2	4	8
37 to 45	5	3	2	4	8
46 to 54	6	3	2	4	8
55 +	Requires quarterfinals following the above pattern				

WHERE PHOTO FINISH IS USED

FOR EIGHT LANES – IN-LANE START					
Declared Entries	Trial Heats	Qualifying to Semi-Final	Semi-Finals Heats	Qualifying to Final	Final
1 to 8	0	-	0	-	1 to 8
9 to 16	0	-	2	3 + next 2 best times	8
17 to 24	3	4 + next 4 best times	2	3 + next 2 best times	8
25 to 32	4	3 + next 4 best times	2	3 + next 2 best times	8
33 to 40	5	4 + next 4 best times	3	2 + next 2 best times	8
41 to 48	6	3 + next 6 best times	3	2 + next 2 best times	8

FOR NINE LANES – IN-LANE START					
Declared Entries	Trial Heats	Qualifying to Semi-Final	Semi-Finals Heats	Qualifying to Final	Final
1 to 9	0	-	0	-	1 to 9
10 to 18	0	-	2	3 + next 3 best times	9
19 to 27	0	-	3	2 + next 3 best times	9
28 to 36	4	6 + next 3 best times	3	2 + next 3 best times	9
37 to 45	5	5 + next 2 best times	3	2 + next 3 best times	9
46 to 54	6	4 + next 3 best times	3	2 + next 3 best times	9
55 to 63	7	3 + next 6 best times	3	2 + next 3 best times	9
64 to 72	8	3 + next 3 best times	3	2 + next 3 best times	9

FOR EIGHT OR NINE LANES – 800 GROUP START					
Declared Entries	Trial Heats	Qualifying to Semi-Final	Semi-Finals Heats	Qualifying to Final	Final
17 to 36	0	-	3	2 + next 2 best times	8
37 to 48	4	3 + next 4 best times	2-in lane	3 + next 2 best times	8

FOR EIGHT OR NINE LANES – 1500					
Declared Entries	Trial Heats	Qualifying to Semi-Final	Semi-Finals Heats	Qualifying to Final	Final
1 to 16	0	-	0	-	1 to 16
17 to 30	0	-	2	4 + next 4 best times	12

31 to 45	0	-	3	3 + next 3 best times	12
46 to 60	4	5 + next 4 best times	2	5 + next 2 best times	12

FOR EIGHT OR NINE LANES – Steeplechase, 3000					
Declared Entries	Trial Heats	Qualifying to Semi-Final	Semi-Finals Heats	Qualifying to Final	Final
1 to 18	0	-	0	-	1 to 18
19 to 34	0	-	2	5 + next 4 best times	14
35 to 51	0	-	3	3 + next 5 best times	14
52 to 68	4	5 + next 8 best times	2	5 + next 4 best times	14

FOR EIGHT OR NINE LANES – 5000 Men					
Declared Entries	Trial Heats	Qualifying to Semi-Final	Semi-Finals Heats	Qualifying to Final	Final
1 to 20	0	-	0	-	1 to 20
21 to 40	0	-	2	5 + next 6 best times	16
41 to 60	0	-	3	4 + next 4 best times	16
Women	0	-	-	See Rule 166.2(c).iv	16

- Whenever the number of competitors reporting for an event makes heats, as required in this Rule, unnecessary, the event shall be run as a final at the time in the program so scheduled for the final, unless other provisions have been made by the Games Committee.

NOTE: For Youth Athletics exception see Rule 303.2(b).

- Whenever the number of competitors reporting, in any heat or round, for an event eliminates the element of competition, the Referee, or one or more persons appointed by the Referee, may reform the heats, redetermine the number of rounds, or redetermine the qualifying procedures for the event, in accordance with this Rule, unless other provisions have been made by the Games Committee.

NOTE 1: For rule applicable to forming heats for Indoor competitions, see Rule 214.

NOTE 2: For rules applicable to forming heats in Youth Athletics competition, see Rule 303.

- Whenever the Games Committee determines that there are too many competitors to run a single final, and the schedule precludes a qualifying round, the event shall be contested in sections as a time-based final. In timed final events, sections shall be derived from the ranked list of declared athletes, arranged in order of qualifying times. Each section, beginning with the fastest, shall be filled to its limit before placing anyone into the next section. If the last section has fewer than three competitors, the slowest ranked competitor(s) from the previous section, as needed, shall be moved to that section. Sections shall be contested in reverse order, slowest to fastest. . The final results of athletes in the event shall be overall according to the results of all sections.

NOTE 1: See Rule 302.2(a) and (b) for Youth Athletics.

NOTE 2: See Rule 332.2(e) for Masters Track and Field.

6. After the Clerk of Course has reported to the Referee the number of competitors ready to start in the first round of a running event and the Referee has designated the number to compete in each heat and the number of heats to be run as well as the number to qualify to the next round, additional competitors shall not be permitted to start.
7. For seeding purposes only, the conversion factor of .24 seconds between fully automatic and manual timing must be used when conversions are made (i.e., the manual time plus the conversion factor equals the Photo Finish time for seeding purposes under Rule 166).
8. When an individual or relay team, having qualified for a subsequent round, withdraws for any reason, no additional individual or relay team shall be advanced to fill the vacated position. When an individual or relay team is disqualified prior to the subsequent round, the qualifiers and seeding shall be re-determined without the disqualified competitor(s) unless the disqualification results in advancement under Rule 163.4, in which case no other advancement shall occur.

NOTE 1: An athlete who is declared with exhibition status prior to an event shall not be considered to be a qualifier for the next round.

NOTE 2: The published Entry Material/Technical Information shall specify alternate policy how vacant positions due to withdrawals in semi-final and/or final rounds may be filled by athletes ranked after those who have qualified from the previous round.

NOTE 3: For Masters exception see Rule 332.2(b).

RULE 167 RUNNING EVENT TIES

1. In determining whether there has been a tie for a qualifying position for the next round based on time, the Photo Finish Judge shall consider, within the same race, the competitor's finish place as determined by Rule 163.1, or between different races, the actual time recorded by the competitors to not greater than 0.001 seconds accuracy.

Whether by time or finishing place, if it is determined that there has been a tie, the tying competitors shall be placed in the next round if it is practical to do so. If that is not practical, lots shall be drawn to determine who shall be placed in the next round.

Where qualifying for the next round is based on place and time, i.e., the first three in each of two heats plus the next two fastest, and there is a tie for the last qualifying position based on place, placing the tied athletes in the next round shall reduce the number of athletes qualifying based on time.

2. In case of a tie for any place in any final, including first place, the tie shall remain.

RULE 168 HURDLES

1. For outdoor competition, the standard distance for hurdle races, which shall have 10 flights of hurdles in each lane, 7 flights for the 300m, and set out in accordance with the following tables, shall be:

Men, U20 Men, U18 Men	Distance from Start to First Hurdle	Distance Between Hurdles	Distance from Last Hurdle to Finish
110m	13.72m	9.14m	14.02m
300m	50.00m	35.00m	40.00m
400m	45.00m	35.00m	40.00m

Women, U20 Women, U18 Women	Distance from Start to First Hurdle	Distance Between Hurdles	Distance from Last Hurdle to Finish
100m	13.00m	8.50m	10.50m
300m	50.00m	35.00m	40.00m
400m	45.00m	35.00m	40.00m

Dimensions: The standard heights of the hurdles shall be:

Distance of Race	Men	U20 Men	U18 Men	Women, U20 Women	U18 Women
110m / 100m	1.067m	0.991m	0.914m	0.838m*	0.762m
300m	0.914m	0.914m	0.838m	0.762m	0.762m
400m	0.914m	0.914m	0.838m	0.762m*	0.762m

* For experimental purposes, women's events may be conducted with a hurdle height of 0.914m (36in.).

NOTE 1: In each case of hurdle height, there shall be a tolerance of $\pm 3\text{mm}$.

NOTE 2: Due to manufacturing variations, hurdles up to 1.000m are also acceptable in the U20 110m Hurdles.

NOTE 3: For Indoor specifications, see Rule 217. For specifications for Masters races, Rule 332.2(i). For specifications for Youth Athletics, See Rule 302.4

NOTE 4: Specifications for the 300m hurdles are different from those in High School.

2. A hurdle shall be of such strength and stability as not to be broken easily by a competitor hitting the same, and if of the reversible or adjustable type, shall be rigid when so adjusted.
3. All races shall be run in lanes. Each athlete shall go over each hurdle and shall keep to the hurdles in his/her own lane throughout the race. Failure to do so shall result in a disqualification unless Rule 163.5 applies.

In addition to the applicable provisions of Rule 163, a competitor shall be disqualified if:

- (a) His/her leg or foot is, at the instant of clearance, beside the hurdle (on either side) and below the horizontal plane of the top of any hurdle; or
- (b) He/she knocks down or displaces any hurdle by hand, torso or the front side of the lead lower limb; or
NOTE: The front side of the lead lower limb includes all front facing parts of the leg from the top of the thigh to the end of the foot.
- (c) He/she directly or indirectly **knocks down a hurdle** in his/her or in another lane in such a manner that there is effect or obstruction upon any other competitor(s) in the race and/or another rule is also infringed.

Provided that this Rule is otherwise observed and the hurdle is not displaced or its height lowered in any manner including tilting in any direction, a competitor may go over the hurdle in any manner.

- (d) He/she directly or indirectly displaces a hurdle in their or in another lane in such a manner that there is a severe effect or obstruction upon any other athlete(s) in the race, and/or another Rule is also infringed.

NOTE: *Situations when an athlete knocks down or displaces a hurdle in another lane should be interpreted in a logical way. For example, an athlete who knocks down or displaces a hurdle in the lane of an athlete who has already gone over that hurdle, or whose displacement did not cause a severe change in the other athlete's progression. Examples of such a change include: alteration of rhythm, shortening or lengthening of the stride, change of direction, impact with the hurdle that would never happen without the displacement. An athlete should not necessarily be disqualified unless they otherwise infringe the Rules, e.g. by moving to an inside lane on the bend or having their foot or leg, at the instant of clearance, beside the hurdle (on either side) and below the horizontal plane of the top of any hurdle. The intent of this Rule is to make it clear that an athlete who in making such an action affects another athlete should be considered for disqualification.*

4. Except as provided in Rule 168.3(b) and Rule 168.3(c), the knocking down of one or more hurdles does not disqualify the athlete nor prevent a record provided standard 3.6kg pull-over weight hurdles have been used.

NOTE: *Under World Athletics Rule 168.9, in establishing a world record a complete set of hurdles of the international type must have been used. For specification of the hurdles, see USATF Rule 168.5 - 168.11.*

5. **Construction** - The hurdles shall be made of metal or some other suitable non-metallic material with the top bar of wood or some other suitable material and shall consist of two bases and two uprights supporting a rectangular frame reinforced by one or more crossbars, the uprights to be fixed at the extreme end of each base. The hurdles shall be of such design that a force of at least 3.6kg (8 lb.) applied horizontally to the center of the top edge of the crossbar is required to overturn it. The hurdles may be adjustable in height for each event. The counterweights must be adjustable so that at each height a horizontal force of at least 3.6kg (8 lb.) and not more than 4.0kg is required to overturn it.

NOTE: *A diagram showing the design of approved hurdles appears in Figure 1.*

6. **Width** - The maximum width shall be 1.20m.

7. **Length** - The maximum length of the base shall be 70cm.

8. **Top Bar** - The top bar shall be 7cm wide and shall be striped in black and white or in some other strong distinctive contrasting colors, also in contrast with the surrounding environment, in such a manner that the lighter stripes appear for at least 22.5cm at each end of the bar. The thickness of this bar shall be between 10 and 25mm and the top edges should be rounded. The bar should be firmly fixed at the extremities. The top bar shall be of a length equal to the width of the lane in which it is placed.

9. **Placement** - The hurdles shall be so placed on the track that the feet of the hurdles shall be on the side of the approach by the competitor. The hurdle shall be so placed that the vertical plane of the side of the top bar nearer to the approaching athlete coincides with the track marking nearest the approaching athlete.

10. **Weight** - The total weight of the hurdle shall be not less than 10 kilograms.
11. **Testing** - To check the resisting force of hurdles, a simple spring balance should be used to apply a pulling force horizontally to the center of the crossbar. Alternatively, use a cord with a hook applied horizontally to the center of the crossbar; take the cord along over a pulley fixed appropriately and load the other end of the cord with weights.
NOTE: *The so-called "rocker" hurdle does not comply with the above specifications.*

RULE 169 STEEPLECHASE

1. The standard distance shall be 3000 meters. Races of 1500 and 2000 meters may also be contested.
2. The 3000 Meter Steeplechase shall have 28 barrier jumps and 7 water jumps. The 2000 Meter Steeplechase shall have 18 barrier jumps and 5 water jumps. The 1500 Meter Steeplechase shall have 13 barriers and 3 water jumps. There shall be five jumps per lap after the finish line has been passed for the first time. The water jump shall be the fourth if that is feasible. The jumps should be evenly distributed, i.e., the distance between the jumps shall be approximately one-fifth of the nominal length of the lap. Because of differences in track design and water jump placement, all steeplechase courses must be individually measured. Generally, only the start line will need to be adjusted. A diagram showing a typical configuration of the barriers on a 400m track with an interior water jump is shown in Figure 2.

NOTE 1: *Adjustment to the barrier spacing may be necessary to ensure that safe distances from a barrier / start line and to the next barrier are maintained before and after the finish line respectively as indicated in the World Athletics Track and Field Facilities Manual.*

NOTE 2: *In the 3000 Meter Steeplechase, the distance from the start to the beginning of the first full lap shall not include any jumps.*

NOTE 3: *In the 2000m event, the first barrier jumped is at the third barrier placement, the one immediately prior to the water-jump. However, if the water-jump is on the inside of the track, the finish line has to be passed twice before the first lap with five jumps.*

3. Each barrier height shall be 91.4cm for Senior and U20 Men's events, 83.8cm for U18 Men's events and 76.2cm for Senior, U20 and U18 Women's events. There shall be a tolerance allowance of $\pm 3\text{mm}$. The barriers shall be at least 3.96m wide and shall be placed on the track so that 30cm of the top bar, measured from the inside edge of the track, will be inside the field. The section of the top bar of the barriers and the barrier at the water jump shall be 12.7cm (5 in.) square. The weight of each barrier shall be between 80 and 100kg, and each barrier shall have on either side a base between 1.2 and 1.4m. All barriers are to be painted with white and black stripes, or in other strong distinctive contrasting colors, also in contrast with the surrounding environment, in such a manner that the lighter stripes, which will be at least 22.5cm wide, are on the outside. See Figure 3. For Masters exception see Rule 332.2(i).

NOTE: *It is recommended that the first barrier taken in the race should be at least 5m wide.*

4. Each competitor shall go over or through the water and shall go over each barrier. An athlete shall be disqualified if he/she:
 - (a) Steps to one side or the other of any barrier or water jump; or

- (b) Has a leg or foot, at the instant of clearance, beside the barrier (on either side) and below the horizontal plane of the top of the barrier.
Provided this Rule is observed, an athlete may go over each barrier in any manner.

5. Water Jump Construction:

- (a) The water jump, including the barrier, shall be 3.66m (\pm 2cm) in length and 3.66m (\pm 2cm) in width. At the start of a race, the surface of the water shall be level with the surface of the track, within a margin of 2cm. The depth of the water closest to the barrier shall be 50cm (\pm 5cm) for approximately 1.20m. From there, the bottom shall have a uniform slope of 12.4 degrees (\pm 1 degree) upwards to the level of the track at the farther end of the water pit.

NOTE: *Construction complying with 2019 specifications (70cm for approximately 30cm) remains valid.*

- (b) The sloped portion of the bottom of the water pit shall be covered with a synthetic surface, or matting, of sufficient thickness to afford a safe landing, and allow for the spikes to grip satisfactorily. See Figure 4.
- (c) The barrier at the water jump shall be 3.66m (\pm 2cm) wide, and shall be firmly fixed to the ground, so that no horizontal movement is possible. The top bar shall be 12.7cm x 12.7cm (5 in. x 5 in.) in thickness and the same height as the others. See Rule 169.3.

RULE 170 RELAY RACES

1. The standard distances for outdoor shall be: 4x100m, 4x100m Mixed, 4x200m, 4x400m, 4x800m, 4x1500m, Shuttle Hurdle Relay, 4x400m Mixed, 'Swedish' Medley Relay (100, 200, 300, 400) and Sprint Medley Relay (200, 200, 400, 800). The standard distances for indoor shall be: 4x400m, 4x800m, Shuttle Hurdle Relay, Sprint Medley Relay (400, 200, 200, 800) and Distance Medley Relay (1200, 400, 800, 1600).

In the case of relay events not covered by this Rule, the relevant competition regulation shall specify any particular rules to be applied and the method by which the relay is conducted.

NOTE 1: *The Medley Relay may be run with the legs in a different order in which case the appropriate adjustments should be made to the application of Rules 170.10, 170.14, 170.15 and 170.16.*

NOTE 2: *For indoor relay event procedure, see Rule 218*

2. Lines 5cm wide shall be drawn across the track to mark the distances of the legs and to denote the scratch line.
3. In the 4x100m, 4x100m Mixed and the 4x200m, the first and second exchanges in the 'Swedish' Medley and the outdoor Sprint Medley relays, each takeover zone shall be 30m long, of which the scratch line is 20m from the beginning of the zone. For the third exchange in the 'Swedish' Medley Relay and in the 4x400m, 4x400m Mixed and longer relays each exchange zone shall be 20m long of which the scratch line is the center. The zones shall start and finish at the edges of the zone lines nearest the start line in the running direction. For each exchange conducted in lanes, a designated official shall ensure that the athletes are correctly placed in their exchange zone. The designated official shall also ensure that Rule 170.5 is observed.

4. The relay baton shall be a smooth hollow circular tube made of wood, metal or other rigid material in one piece. Its length shall be between 28 and 30cm. Its outside diameter shall be 4cm \pm 2mm and it shall weigh not less than 50g. It should be a color so as to be clearly visible during the race. No material or substance may be applied to the baton. In road relay races, in lieu of a baton, runners shall exchange a sash or wristband provided by race officials.
5. **Check Marks** - When all or the first portion of a relay race is being run in lanes, a runner may place one check mark on the track within his/her own lane, by using self-adhesive tape, maximum 5cm x 40cm, of a distinctive color which cannot be confused with other permanent markings. For a cinder or grass track, the runner may make a check mark within his/her own lane by scratching the track. In either case no other check mark may be used. The Umpires shall direct the relevant competitor to adapt or remove any marks or objects not complying with this Rule. If the competitor does not, the Umpire shall remove the marks or objects.
NOTE 1: *Adhesive tape otherwise complying with this Rule may be torn into one or more pieces to make a single marker of a different shape to stand-out more clearly.*
NOTE 2: *For Youth Athletics exception see Rule 302.2(g).*
6. The 4x100m and the 4x100m Mixed races shall be run entirely in lanes.
7. The 4x200m race may be run in any of the following ways:
 - (a) Where possible, entirely in lanes,
 - (b) In lanes for the first two legs, as well as that part of the third leg up to the nearer edge of the break line described in Rule 160.8(c), where runners may leave their respective lanes,
 - (c) In lanes for the first leg up to the nearer edge of the break line marked and described in Rule 160.8(c), where runners may leave their respective lanes.
NOTE: *Where not more than four teams are competing, and option (a) is not possible, option (c) is recommended.*
8. The 4x400m and the 4x400m Mixed races may be run in either of the following ways:
 - (a) In lanes for the first leg, as well as that part of the second leg up to the nearer edge of the break line described in Rule 160.8(c), where runners may leave their respective lanes,
 - (b) In lanes for the first leg up to the nearer edge of the break line marked and described in Rule 160.8(c), where runners may leave their respective lanes.
NOTE: *Where not more than four teams are competing, option (b) is recommended.*
9. The 4x800m race may be run in either of the following ways:
 - (a) In lanes for the first leg up to the nearer edge of the break line marked and described in Rule 160.8(c), where runners may leave their respective lanes,
 - (b) Without the use of lanes.
10. The 'Swedish' Medley Relay and the outdoor Sprint Medley Relay races should be run in lanes for the first two legs, as well as that part of the third leg up to the nearer edge of the break line marked and described in Rule 160.8(c), where runners may leave their respective lanes.

11. The Distance Medley Relay and the 4x1500m race shall be run without the use of lanes.
12. The Shuttle Hurdle Relay consists of four members running the Hurdles in adjacent lanes in opposite directions using the same hurdle height, spacing, and distance as the standard Hurdle event. The passing zone shall be 1.22m in front of each start line. After the race start, each team member must be motionless in a set position when they start and shall start only after the incoming team member's torso breaks the plane of the leading edge of the passing zone. No baton or other exchange is required. Otherwise, all individual hurdle rules apply to each hurdler. For Masters exception see Rule 332.2(g).
13. In all relay exchanges, runners are not permitted to begin running outside their exchange zones, and shall start within their exchange zone. If a runner does not follow this Rule, his/her team shall be disqualified.
14. In the 4x400m and the 4x400m Mixed races, the third and fourth leg runners, and in the 'Swedish' Medley Relay and outdoor Sprint Medley Relay, the final leg runner, shall, under the direction of a designated official, place themselves in their waiting position in the same order (inside to out) as the order of their respective team members as they pass the point 200m from the finish of their leg. Once the incoming runners have passed this point, the waiting runners shall maintain their order, and shall not exchange positions at the beginning of the exchange zone. If a runner does not follow this Rule, his/her team shall be disqualified.
NOTE: *In the 4x200m relay race, not run entirely in lanes, the runner in the fourth leg shall line up in the order of the start list (inside to out).*
15. In any race, when lanes are not used, for a given exchange, waiting runners may take an inner position on the track as incoming team members approach, provided they do not jostle or obstruct another runner so as to impede that runner's progress. In the 4x200m, 4x400m, 4x400m Mixed, 'Swedish' Medley Relay and outdoor Sprint Medley Relay, waiting runners shall maintain the order in accordance with Rule 170.14. If a runner does not follow this Rule, his/her team shall be disqualified.
16. A baton shall be used for all relay races held in the stadium and shall be carried by hand throughout the race. Competitors are not permitted to wear gloves or to place material (other than those permitted by Rule 144.4(e)) or substances on their hands or on the baton in order to obtain a better grip of the baton. If dropped, it shall be recovered by the runner who dropped it. He/she may leave any assigned lane or the track to retrieve the baton provided that, by doing so, the distance to be covered is not lessened and no other runner is impeded while retrieving the baton. When crossing the finish line, the baton shall be carried by the relevant competitor. Otherwise, if a runner does not follow this Rule, his/her team shall be disqualified.
17. If during the race a competitor takes or picks up the baton of another team, his/her team shall be liable to disqualification. The other team should not be penalized unless an advantage is obtained.
18. The baton shall be passed entirely within the exchange zone. The passing of the baton commences when it is first touched by the receiving runner and is completed the moment it is in the hand of only the receiving runner. Each of these actions (the first touch and the baton only in the hand of the receiver) shall occur within the exchange

zone. In relation to the exchange zone, it is only the position of the baton that is decisive. Passing the baton outside the exchange zone shall result in disqualification.

19. Runners, before receiving and/or after handing over the baton, should remain in their respective lanes or maintain position until the course is clear to avoid obstruction to other competitors. Rule 163.5 shall not apply to these athletes. Should any runner willfully impede a member of another team by running out of position or lane at the finish of the leg, the team of the impeding runner shall be disqualified.
20. Assistance by pushing or by any other method shall result in disqualification.
21. Any four athletes from among those entered for the competition, whether for the relay or any other event, may be used in the composition of the relay team for any round. However, once a relay team has started in a competition, only four athletes may be used as substitutes in the composition of the team. The composition of the relay team and the order of running shall be officially declared no later than the published first call time (the time by which the competitors must be present in the call room) for their respective heat in each round of the competition. Each member of a relay team may run one leg only. Except for Youth competitions, the team shall compete as named and in the declared order. If a team does not follow this Rule, it shall be disqualified.
NOTE: *For Youth Athletics exception see Rule 302.3.*
22. In the case of a handicap relay race, the runner on the first leg is allowed the total handicap allowed each team. While the order of running may be changed as between the second, third, and fourth members of the team, there may be no change in the first runner who has been allowed the team's handicap. In all handicap medley races, the longest distance must be run first.
23. Unless otherwise herein permitted for international competition, or as stated upon the entry blank issued for an athletic meet other than for a National, Regional or Association Championship of USATF, all members of each relay team must be duly accredited representatives of a single club, school, college, or athletic organization.
NOTE: *For Masters exception see Rule 332.1(a).*
24. For Championships held on more than a single day, heats shall be held for relay races, if necessary. For Championships held on a single day, relays may be conducted in sections.
25. All members of the relay team must be identifiable as team members. Team identification shall be clearly visible and shall distinguish one team from another. Where this is not accomplished by the meet's issuing items such as letters or distinguishing numbers, team members shall wear an identifying article, such as an identical singlet or shirt.
NOTE: *For Youth Athletics exception see Rule 302.3(d). For Masters exception see Rule 330.5.*
26. In the 4x100m Mixed Relay and the 4x400m Mixed Relay, each team shall be composed of two men and two women. The running order shall be Man, Woman, Man, Woman.
NOTE: *For Youth Athletics exception see Rule 302.3(c)*

SECTION III FIELD EVENTS

RULE 180 GENERAL RULES

1. The Referee shall have the power to change the time or location of the competition in any field event after it has started only if extreme conditions warrant it. Whenever it is feasible, such a change shall be made only after a round of trials in progress has been completed.

NOTE: *The fact that the wind direction has changed is never a justification for changing the time, or reversing the direction of the runway, or changing the direction of throwing, after the event has started.*

2. In all scratch events in the Pole Vault and High Jump, the order of trials shall be determined by lot by the Games Committee. Each competitor shall have one attempt in the order drawn, and then those who have failed, if any, shall have a second trial in their regular order, and those who have failed a second time, if any, shall have a third trial in their regular order (for further details see Rule 181).
3. The order of competition shall be determined by the applicable meet entry material/Technical Information for the competition, otherwise by lot by the Games Committee.

4. In all field events other than the High Jump and Pole Vault:
 - (a) No competitor shall have more than one trial recorded in any one round of trials of the competition.
 - (b) When there are more than eight competitors, each competitor shall be allowed three trials. The eight competitors with the best valid and measured performances (or nine if nine lanes are used around the track) shall be allowed three additional trials, unless the entry material/Technical Information provides otherwise. Ties for the final qualifying position for additional trials shall be broken by applying Rule 180.18.

NOTE 1: *The Games Committee may specify an alternate number of competitors (more or fewer) who may have additional trials after the third, and specify the number of such trials, provided that the total number of trials is no more than six.*

NOTE 2: *When fewer than those authorized for additional trials achieve a valid measured mark, it is only those competitors allowed any additional trials.*

- (c) When there are eight or fewer competitors (or nine if nine lanes are used around the track), all shall be allowed six trials, unless the entry material/Technical Information provides otherwise. Any competitor(s) failing to achieve a valid trial during the first three rounds of trials shall compete in any subsequent rounds of trials before those with valid trials, and in the same relative order according to the original draw, excepting paragraph (f).
- (d) In the competition proper, in a Championship competition, if there are resident and/or non-resident aliens among the leading competitors after the completion of the preliminaries, American citizens in order of placement equal to the number of full lanes around the track, but not to exceed nine (9) shall advance for any subsequent additional attempts.

- (e) In all competitions, the order of competition for all subsequent rounds of trials shall be in reverse order of the best performance in the first three rounds of trials. The entry material/Technical Information may specify that the competing order be changed again after any further round of trials after the third. When the competing order is to be changed and there is a tie for any position, those tying shall compete in the same relative order according to the original draw. If a competitor is permitted by the Referee to continue in a competition under protest in accordance with Rule 146.7(b), such competitor shall compete in subsequent rounds of trials before all others continuing in the competition and if more than one, then in the same relative order according to the original draw.
 - (f) All competitors shall take their first trials in order; then all shall take their second trials in like order, etc. unless other provisions of this rule apply.
- NOTE:** *For Youth Athletics exception see Rule 302.5(q).*
- 5. If, for any reason beyond his/her control, a competitor is hampered in a trial, is unable to take the trial or the trial cannot be correctly recorded, the Referee shall have the authority to award the competitor a substitute trial or to reset the time either partially or in full. No change in the competition order shall be permitted. A reasonable time shall be allowed for any substitute trial according to the particular circumstances of the case. In cases when the competition has progressed before the substitute trial is awarded, the substitute trial should be taken before any other subsequent trials are then made by the competitor.
 - 6. Trials shall be recorded as follows:
 - (a) Except in High Jump and Pole Vault, a valid trial shall be indicated by the measurement taken. In High Jump and Pole Vault, it shall be indicated by the symbol 'O';
 - (b) A failure shall be indicated by the symbol 'X';
 - (c) If the athlete forgoes a trial (a pass) it shall be indicated by the symbol '-'.
 - 7. A qualification round shall be held in field events in which the Games Committee determines the number of competitors is too large to allow the competition to be conducted satisfactorily in a competition proper. Where a qualification round is held, all competitors must compete in, and qualify through, that round except that the body having the control over a competition may, for one or more events, authorize the conduct of additional qualification round(s) either at the same or at one or more earlier competition(s) to determine some or all of the competitors who shall be entitled to participate and in which event round of the competition. Such procedure and any other means (such as achieving entry standards during a specified period, by specified placing in a designated competition or by specified rankings) by which an athlete is entitled to participate, and in which event round of the competition, shall be set out in the entry material/Technical Information for each competition.
 - (a) Twelve (12) competitors and ties, unless otherwise provided in the published meet information, that remain after applying Rules 180.19, 181.9(a), and 181.9(b) shall advance to the competition proper. In the High Jump and Pole Vault, the competitors who have not withdrawn or been eliminated after three consecutive failures shall continue to compete until the end of the last trial at the height set as the qualifying standard by the Games Committee, unless the number advancing to the final, as determined by this Rule, has been reached. If, after jumping concludes at any height at or below the qualifying standard, there remain

fewer than 12 athletes in competition, then additional qualifiers shall be added by applying Rules 181.9(a) and (b). When competition is held in two simultaneous groups, it is recommended that the bar be raised to each height at the same time for each group.

NOTE: *The meet entry material/Technical Information for a competition may specify how vacant positions in the competition proper, due to withdrawals following a qualification round, may be filled by athletes ranked next after those qualified.*

- (b) In all field events except the High Jump and Pole Vault, three (3) attempts shall be permitted each competitor to make the qualifying standard established by the Games Committee.
 - (c) A competitor who has been determined to have qualified for the competition proper shall not be allowed to continue in the qualifying competition.
 - (d) Where there are enough competitors to warrant it, it is recommended that the qualifying competition be divided into two or more groups at random. Unless there are facilities for the groups to compete at the same time under similar conditions, each group shall commence its practice trials immediately after the previous group has finished.
 - (e) Performances made in the qualifying competition shall not be considered part of the competition proper or count in deciding the final standing in the event.
 - (f) In a qualifying competition, the competitors shall compete in the order drawn by lot. At the end of the qualifying competition, the order for competing in the competition proper shall be determined by Rule 180.3.
8. When competition in a field event is conducted in flights, the Games Committee may determine whether there should be a practice period between flights, and/or the length of the period or the number of practice trials.
9. When there are more than 15 competitors in a field event and the time available for the meet makes the holding of a qualifying competition impractical, the following procedure may be used:
- (a) In throwing and horizontal jumping events, the first three rounds of trials may be conducted in flights.
 - (b) In the vertical jumping events, for large fields, the Games Committee shall select one of the following options:
 - i. Utilize a qualifying competition according to Rule 180.7.
 - ii. Utilize two flights following the normal order of competition. The overall placing will be determined by combining the results of both flights. Ties shall be broken, only as necessary, as determined by the Games Committee.

Under all other circumstances, preliminary trials or finals shall not be conducted in flights in the competition proper.

NOTE 1: *For Youth Athletics exception see Rule 302.5(b).*

NOTE 2: *For Masters exception see Rule 332.3(a).*

10. Where there is no formal declaration procedure, anyone entered shall be accepted.

- (a) When there is not a posted Call Room Schedule, if a competitor misses a turn in a field event for any reason, that competitor shall not be permitted to have practice trials using the competition area (see Rule 180.17(c)) or take the trial or trials so missed, but may be permitted to take his/her remaining trials if he/she was entered in the event before it began.

If a competitor by his/her own decision makes a trial in an order different from that previously determined, the competitor shall be warned (or disqualified in case of a second infringement) according to Rule 125.7, but the result of the trial (valid or failure) will stand in the case of a warning (first infringement).

- (b) In the High Jump and Pole Vault, the Chief Field Judge of the event shall permit a tardy declared contestant to start at the height of the bar at the time of his/her arrival. The bar shall not be lowered to permit an athlete to make up jumps at earlier heights.

- (c) If a competitor is entered in both a track and a field event, or in more than one field event taking place simultaneously, the appropriate Referee or Chief Field Judge may, for one round of trials at a time, or for each trial in High Jump and Pole Vault, allow the competitor to take a trial out of the regular order. See Rule 180.11.

NOTE 1: *In field events, the Referee shall not allow a competitor to take a trial in a different order in the final round of trials. The Referee may allow a competitor to do so during any earlier round of trials. In Combined Events, a change may be allowed in any round of trials. This subsection applies to one attempt at a time. It does not permit an athlete to take a given attempt after the next round of trials (or next trial in the vertical jumps) has begun.*

NOTE 2: *For comparable provisions applicable to Youth Athletics competition, see Rule 302.5(p) and Rule 302.5(q).*

NOTE 3: *Rule 180.10 applies to all field events, including those contested in a Combined Event.*

11. A competitor may not leave the immediate area of a field event during the progress of the competition unless the competitor has the permission of the Chief Judge and is accompanied by an official. If possible, a warning should first be given but for subsequent instances or in serious cases the athlete shall be disqualified.

Competitors need not be excused or accompanied while effecting the provisions of Rule 144.4(a) or Rule 144.4(i). Competitors excused to compete in another event need not be accompanied.

If the athlete subsequently is not present for an excused trial, it shall be deemed that the athlete is passing once the period allowed for the trial has elapsed. If the athlete is not present for any or subsequent trial within the normal competing order, it shall be counted as a failure once the period allowed for the trial has elapsed.

NOTE: *When excused for another event, an athlete may pass multiple trials or rounds.*

Time Allowed for Trials

12. (a) The official responsible for the event shall indicate by verbal and visual signal to the competitor that all is ready for the trial to begin, and the period allowed for that trial shall commence from that moment. If the competitor confirms his/her pass the official shall not require that the time for the next competitor commence until the time period for the

passing competitor has elapsed. In the Pole Vault, the trial and the time allowed for it shall commence when the uprights have been adjusted to previous wishes of the competitor (see Rule 183.1(b)), at which time the official responsible for the event shall so indicate to the competitor. If the competitor wishes to change markers allowed in Rule 180.24 or 180.25, it should be done during the applicable time limit.

NOTE 1: *The officials and the Referee in particular must be fully aware of the current competition environment, including direction from Event Presentation, when deciding when to start the clock or to 'time out' and call a failure.*

NOTE 2: *Particular circumstances which should be taken into account are the availability of the runway for an athlete's trial in High Jump and Javelin Throw, when Track Events are being held simultaneously in the same competition area, and the distance for athletes to walk to and through the cage to reach the circle to take their trial in Discus Throw and Hammer Throw.*

NOTE 3: *The Referee may determine that factors independent of the competitor's own action, (e.g. marks removed or weather issues) exist to justify awarding additional time.*

- (b) A clock that shows the remaining time allowed should be visible to the competitor. In addition, an official shall raise overhead and keep raised a yellow flag, or another suitable indicator, for the final 15 seconds remaining of the time allowed. When the time expires, the yellow flag shall be lowered. In addition to the use of flags and/or a clock, a verbal indication of time remaining is acceptable.
- (c) If after the time for a trial has begun, a competitor subsequently decides not to attempt that trial, it shall be considered a failure once that period allowed for the trial has elapsed.
- (d) If the time allowed lapses once the competitor has started a trial, that trial should be allowed
- (e) The following times shall not be exceeded. If the time is exceeded, unless a determination is made under Rule 180.5, the trial shall be recorded as a failure:

TIME IN MINUTES FOR INITIATING A FIELD EVENT TRIAL

Total # of Athletes remaining in the competition at the Start of the Round.	Individual Event			Combined Event		
	HJ	PV	Other	HJ	PV	Other
More than 3 or the very first trial for a competitor.	1	1	1	1	1	1
2 or 3	1.5	2	1	1.5	2	1
1	3	5	-	2	3	-
Consecutive Trials	2	3	2	2	3	2

NOTE 1: *A reoriented table is available as Figure 18 in Appendix 1.*

NOTE 2: *See Rule 332.3(e) and 332.3(g) for additional Masters conditions.*

- (f) In the High Jump and Pole Vault, any change in the time period allowed for a trial shall not be applied until the bar is placed at a new height, except the time specified for consecutive trials shall be applied whenever a competitor has two or more consecutive trials, for any reason, within or between a bar height. The time allowed shall be the greater if more than one situation is applicable. The total number of competitors remaining in the competition includes those who could be involved in a jump-off for first place. When only one competitor, who

has won the competition and remains in High Jump or Pole Vault, is attempting a World Record or other record directly relevant to the competition, the time limit shall be increased by one minute to those set out in Rule 180.12(e).

NOTE: *When more than one pit is being used in the High Jump or Pole Vault and the bar heights are not raised simultaneously throughout the competition, time limits shall be determined by the number of athletes competing on each pit, not the total on all pits.*

- (g) When the clock or the time set forth above is started, the time should not be restarted except as provided in Rule 180.5 or in cases where the Chief Official of the event judges that there is good cause to do so. During that time, an athlete may not pass a height in the High Jump or Pole Vault or an attempt or trial in any other event without being charged with a trial unless otherwise provided by the Chief Official of that event.
13. The completion of valid trial shall be once the Chief Judge has determined that:
- (a) For vertical jumps there is no failure according to Rules 182.3, 183.5 or 183.6,
 - (b) The competitor leaves the landing area in the horizontal jumps according to Rule 185.4, or
 - (c) The competitor leaves the circle or runway in the throwing events according to Rule 187.5 or Rule 193.1(f).
14. In all handicap events, the competitor having the greatest allowance shall make the first trials, and so on, in regular order, up to the competitor at scratch or with least allowance, who shall have the last trial.
15. The Games Committee should place a wind sock near the take-off in all jumping events and near the discus and javelin, to enable competitors to determine the approximate direction and strength of the wind.
16. In all throwing events, no flags or markers will be placed in the landing sector.
17. (a) Where possible, a practice area and period should be provided other than at the site of competition. Where no outside practice area is provided, the Games Committee shall establish the length of time permitted for practice throws. These should be made in order of the draw, and competitors should be called by name under the supervision of the judges.
- (b) A competitor may take no more than two practice trials or throws for each turn in line at the competition area. These practice trials or throws shall be taken only from the runway or circle being used for the event.
 - (c) Once a competition has begun, competitors are not permitted to use implements for practice purposes or to use the throwing circles, runways, or area within the sectors for practice trials, with or without implements. See Rule 180.8, which authorizes practice when an event is conducted in flights. If an event is delayed for an hour or more due to circumstances that fall outside the normal course of competition, all competitors shall be allowed a practice period, the length of which shall be determined by the Referee.
- NOTE:** *For Youth Athletics exception to subparagraph (c), see Rule 302.5(r). For Masters Track and Field see Rule 332.3(c).*

Ties

18. In horizontal field events where the result is determined by distance, the second-best performance of the competitors having the same best distance shall determine whether there has been a tie. Then, if necessary, the third best, and so on. After applying this procedure, in the case of a tie for any place, including first place, the tie shall remain. For vertical jumps, see Rule 181.9.
19. Each competitor shall be credited with the best of his/her attempts, including in the case of the High Jump and the Pole Vault those achieved in deciding a tie for first place. See Rule 262.7 in regard to records.
20. Performances within a competition conducted to break a tie for administrative purposes, such as to determine advancement in team selection, are not part of the competition proper and therefore not eligible to alter the original placing or performances.

Runways for Jumping and Throwing Events

21. In the jumping events, the length of the run is unlimited. The minimum length of runways is 40m for the Long Jump, Triple Jump and Pole Vault. The minimum length is measured from the relevant take-off line or from the 'zero' line. For the High Jump, the minimum width of the runway apron shall be 16m and the length shall be 15m. On athletic fields used for Championship competitions, the minimum length suggested for runways is 25m for the High Jump apron and 45m for the Long Jump, Triple Jump, and Pole Vault runways. The runway should have a width of 1.22m \pm 0.01m (4 ft.). The runway should be bordered by white lines 5cm in width (except in the High Jump).

Along the runway: mark lines 2.5cm wide and 15cm long from 6.0m from the back of the top of the stop-board to the end of the runway in one meter intervals. Stenciled numbers may be added to show the distance from the take-off board or top of the back of the stop-board.

22. In the Javelin Throw, the length of the runway shall be not less than 30m. Where feasible, the minimum length shall be 33.5m. The runway shall be marked by two parallel lines 5cm wide and 4m apart.
23. (a) The maximum allowance for lateral inclination of runways for jumping events and the Javelin Throw shall not exceed 1:100, unless an exemption from World Athletics exists.
- (b) The maximum allowance for overall downward inclination in the last 40m of the runway for jumping events and in the last 20m of the runway for the Javelin Throw shall not exceed 1:1000 in the running direction.
- (c) In the High Jump, the maximum overall downward inclination of the runway and take-off area in the last 15m shall not exceed 1:167 (0.6%) along any radius in the direction of the center of the semicircular area located midway between the uprights and having the minimum distance specified in Rule 180.21. The landing area should be placed so the competitor's approach is up the inclination.
NOTE: *Construction complying with 2019 specification (1:250) remains valid.*

Markers

24. For throws made from a circle, a competitor may use one marker only. This marker may be placed only on the ground in the area immediately behind or adjacent to the circle. The marker must be temporary, in position only for the duration of each competitor's own trial, and shall not impair the view of the judges. No personal markers may be placed in or beside the landing area.

The Chief Judge of the event shall direct the relevant athlete to adapt or remove any marks not complying with this rule. If the athlete does not, the Judge shall remove the marks.

25. (a) No marks shall be placed on a runway, but a competitor may place one or two markers, supplied or approved by the Games Committee, alongside the runway to assist in the run-up or take-off. If such markers are not supplied, a competitor may use adhesive tape but not chalk or similar substance or anything that leaves indelible marks. For the High Jump, markers may be placed in the runway apron.

(b) Each marker shall be a single piece only.

(c) For the Pole Vault, the Games Committee should place suitable and safe distance markers beside the runway at each 50cm between the points 2.5m to 5m from the 'zero' line and at each 1.0m from the 5m to the 15m point.

NOTE 1: *Meet management may mark the entire runway outside its edge to indicate the distance from the take-off board or the top of the back of the stop-board. Suggested methods of marking are as follows:*

(a) *At the take-off area: mark lines 2.5cm wide and 30cm long from 1.5m to 4.5m in 15cm intervals from the top of the back of the stop-board. Stenciled numbers may be added to show the distance from the take-off board or top of the back of the stop-board.*

(b) *Along the runway: mark lines 2.5cm wide and 15cm long from 6.0m from the back of the top of the stop-board to the end of the runway in one meter intervals. Stenciled numbers may be added to show the distance from the take-off board or top of the back of the stop-board.*

NOTE 2: *For rules applicable to runways for Indoor competitions, see Rules 219-221.*

NOTE 3: *For Youth Athletics exception see Rule 302.5(j).*

26. (a) In all throwing events, no flags or markers displaying a distance shall be placed in the landing sector.

(b) A distinctive flag or marker may be provided to mark the existing World Record and, when appropriate, the existing Area, National or Meet Record. The marker shall be placed along, and outside the landing area / sector.

(c) The Games Committee should place a wind sock near the take-off in all jumping events and near the discus and the javelin, to enable competitors to determine the approximate direction and strength of the wind.

RULE 181 HIGH JUMP AND POLE VAULT

The following subdivisions shall apply to both the High Jump and the Pole Vault:

1. The initial height of the crossbar and the subsequent heights to which the crossbar shall be raised shall be determined by the Games Committee, and shall be announced

to the competitors before the commencement of the competition. In jump-offs to decide ties for first place, the bar will be raised and lowered in accordance with Rule 181.9(d).

NOTE: *For Youth Athletics exception see Rule 302.5(o).*

2. All measurements must be made in accordance with Rule 148, perpendicularly from a point on the same level as the takeoff to the lowest part of the upper side of the bar. Any measurement of a new height shall be made before competitors attempt such height. A new measurement shall also be made when a new crossbar is substituted. In all cases of attempts at record heights, the judges shall check the measurement of the bar when the bar has been placed at the record height and they must re-check the height before each subsequent record attempt if the bar has been displaced for any reason or touched since last measured.

NOTE: *Judges should ensure, before commencing competition, that the underside and front of the crossbar are distinguishable, and that the bar is always replaced with the same surface uppermost and the same surface to the front.*

3. No marks shall be placed in any pit or landing area.
4. In scratch competitions, the competitors shall compete in the order drawn by lot, except as permitted under Rule 180.10 (a), (b) and (c). In handicap competitions, the competitor with the greatest allowance shall make the first trial, and so on. Each competitor shall have the opportunity to make an attempt, or to forego such opportunity in the order drawn; those who have failed shall have a second opportunity in the same order and those who have failed a second time shall have a third opportunity in the same order.
5. In non-championship competition, at the discretion of the Games Committee, vertical jump competitions may be held in a different format to that provided under this rule, including limiting the total number of heights or trials which a competitor may attempt.

6. A competitor may commence jumping or vaulting at the starting height or at any subsequent height and may jump or vault at their own discretion at any subsequent height. If a competitor forgoes (passes) a trial at a certain height, that competitor may not make any subsequent trial at that height except in the case of a jump-off. Three consecutive failures, regardless of the height at which any of such failures occur, disqualifies the competitor from further jumping or vaulting except in the case of a tie for first place. If one or more competitors are not present when all other competitors who are present have completed the competition, the Referee shall deem that such absent competitors have forfeited the right to continue in, and abandoned, the competition once the period for one further trial has elapsed.

NOTE 1: *The effect of this Rule is that a competitor may forego (pass their second or third attempts at a particular height (after failing the first or second time) and still jump or vault at a subsequent height.*

NOTE 2: *For Youth Athletics exception see Rule 302.5(p).*

7. Unless there is only one competitor remaining who has won the competition:
 - (a) The bar shall never be raised by less than 2cm in the High Jump and 5cm in the Pole Vault after each round; and
 - (b) The increment of the raising of the bar shall never increase.

- (c) A competitor who has won the competition is entitled to continue jumping or vaulting until he/she has forfeited the right to compete further. Notwithstanding the provisions of this Rule, the heights to which the bar is to be raised shall be decided after consulting the competitor, except in combined event competitions.

NOTE 1: *For Combined Events, see Rule 200.6.*

NOTE 2: *See Rule 332.3(e) and 332.3(g) for additional Masters conditions*

- 8. When it is clear that the bar has been displaced by a force not associated with the competitor (e.g., a gust of wind)
 - (a) If such displacement occurs after the competitor has cleared the bar without touching it, the attempt shall be considered successful, and
 - (b) If such displacement occurs under any other circumstances, a replacement attempt will be awarded.

NOTE: *It is a foul if the crossbar is displaced by the pole hitting the crossbar unless in the judge's opinion, an effort was made by the competitor to push the pole away from the crossbar when the athlete released the pole.*

Placing - High Jump and Pole Vault:

- 9. If two or more competitors have the same best heights, the procedure to decide places is the following:
 - (a) The competitor with the lowest number of jumps at the height which was their best height in the competition shall be awarded the higher place.
 - (b) If applying (a) will not decide, the competitor with the lowest total of failures throughout the competition up to and including the height last cleared shall be awarded the higher place.
 - (c) If applying (b) will not decide, the competitors involved shall be awarded the same place unless it concerns first place.
 - (d) If it concerns first place, the competitors tying shall jump-off, described as follows, unless otherwise decided either in advance according to the Technical Regulations applying to the competition, or before the start of the event by the appropriate Referee. If no jump-off is held, including where the relevant competitors at any stage decide not to jump further, the tie for first place shall stand. This rule shall not apply to the Combined Events.
 - i. Tying competitors must make a trial at every height until a decision is reached.
 - ii. Each competitor has one trial at each height.
 - iii. The jump-off shall start at the next height, determined in accordance with Rule 181.1, after the height last cleared by the tying competitors.
 - iv. If no decision is reached, the bar shall be lowered (if all have failed) or raised (if two or more have cleared) by 2cm in the High Jump and 5cm in the pole vault.
 - v. A competitor who does not jump at any height automatically forfeits any claim to the higher place. If only one other competitor remains, that competitor is declared the winner regardless of whether that height is attempted.

NOTE: The following illustrates the application of subparagraph 9d, resolving a tie for first place in the High Jump or Pole Vault.

Heights announced by the Chief Judge at the beginning of the competition: 1.75m, 1.80m, 1.83m, 1.86m, 1.88m, 1.90m, . . .

Com- petitor	Height and Performance (m)							Total Fails	Jump Off (m)			Final Place
	1.75	1.80	1.83	1.86	1.88	1.90	1.92		1.88	1.86	1.88	
A	O	X0	O	XO	-	XX-	X	2	X	O	X	2
B	XO	O	-	XO	-	-	XXX	2	X	O	O	1
C	-	XO	XO	XO	-	XXX		3				3

O = cleared X = failed - = did not jump

All jumpers, A, B, and C, cleared 1.86m and did not clear any subsequent height. Rules 181.9(a), (b), (c) and (d) are now applied since all three competitors have the same number of jumps at the height last cleared. The judge now calculates the total number of failures, up to and including the height last cleared, for each competitor. Jumper C has more failures than either A or B and is therefore awarded third place. Jumpers A and B have the same number of failures, therefore they must jump off to determine first place. The next height in the announced progression, after the tying height of 1.86m, is 1.88m. Therefore, 1.88m is the height at which the jump-off must start. The tie for first was broken in the jump-off when Jumper B cleared 1.88m, and A failed that height. Jumper B was awarded first place and A second place.

- (e) If it concerns any other place, the competitors shall be awarded the same place in the competition.

High Jump and Pole Vault Apparatus

10. **Uprights** - Any style or kind of uprights or posts may be used provided they are rigid. In the High Jump, the uprights should be sufficiently tall to exceed each height to which the bar is raised by at least 10cm. For the Pole Vault, cantilevered uprights shall be used. For the Pole Vault, it is required that the metallic structure of the base of the uprights be covered with padding of appropriate material in order to provide protection to an athlete who may land on it.

NOTE: The uprights and landing area of the High Jump should be positioned such that there is clearance of at least 10cm between them and the landing area when in use, to avoid accidental displacement of the crossbar by the movement of the landing area causing contact with the uprights.

11. **Crossbar** - The crossbar shall be of fiberglass or other suitable material, circular in cross-section. The diameter of the circular bar shall be at 3cm (± 1mm). It shall be colored so as to be visible.

The crossbar shall consist of three parts: the circular bar and two end pieces, each 30-35mm wide and 15-20cm long, for the purpose of resting on the supports of the uprights. These end pieces shall be hard and smooth. They shall be circular or semicircular with one clearly defined flat surface on which the bar rests on the crossbar supports (see Figure 7). These flat surfaces may not be higher than the center

of the vertical cross-section of the crossbar. The crossbar shall have no bias and, when in place, shall sag a maximum of 2cm for the high jump and 3cm for the pole vault.

SUGGESTED CONTROL: *Hang a 3kg weight in the middle of the crossbar when in position. It may sag a maximum of 7cm (High Jump) or 11cm (Pole Vault) with the end pieces and supports remaining in complete contact*

12. **Crossbar in the High Jump** - The crossbar shall be not less than 3.98m or more than 4.02m in length. The distance between the uprights shall not be less than 4.00m or more than 4.04m. The maximum weight of the crossbar shall be 2.0kg.
13. **Crossbar in the Pole Vault** - The crossbar shall not be less than 4.48m nor more than 4.52m in length. The maximum weight of the crossbar shall be 2.25kg.
14. **Indicator Lines** -
 - (a) High Jump: A white line 50mm wide shall be drawn on the ground (usually with adhesive tape or similar material). The edge of the line nearest to the take-off area is drawn along the vertical plane through the edge of the crossbar nearest to the take-off area, and extends for 3 meters on either side of the uprights.
 - (b) Pole Vault: A white line 1cm wide shall be drawn on the ground at right angles to the axis of the runway, in line with the back end of the box ('zero' line). A similar line, up to 5cm wide, shall appear on the surface of the landing area and be prolonged as far as the outside edge of the uprights. The edge of the line nearer to the approaching competitor shall coincide with the back end of the box. This will facilitate the determination of the zero point and the checking of the uprights.
15. **Supports for Crossbar in the High Jump** - The supports for the crossbar shall be flat and rectangular, 4cm wide and 6cm long. They shall be firmly fixed to the uprights and immovable during the jump, and shall each face the opposite upright. The ends of the crossbar shall rest on them in such a manner that if the crossbar is touched by a competitor, it will easily fall to the ground, either forwards or backwards. The surface of the supports shall be smooth. The supports shall be the same height above the takeoff area immediately below each end of the crossbar. The supports shall not be covered with rubber or with any other material which has the effect of increasing the friction between the supports and the end pieces of the crossbar.
16. **End Space** - There shall be a space of at least 1cm between the ends of the crossbar and the uprights for the high jump.
17. **Support for Crossbar in Pole Vault** - The crossbar shall rest on pegs so that if it is touched by the competitor or the pole, it will fall easily to the ground in the direction of the landing area. The pegs shall be without notches or indentations of any kind, of uniform thickness throughout and not more than 13mm in diameter. They must not extend more than 55mm from the uprights, which should for Youth and Masters and shall for all others, extend 35-40mm above the pegs. The distance between the pegs shall not be less than 4.28m or more than 4.37m. The pegs may not be covered with rubber or with any other material that has the effect of increasing friction **between the pegs and the end pieces of the crossbar.**

NOTE: *To facilitate the use of a landing area 6m wide (see paragraph 19, below), the pegs supporting the crossbar may be placed upon extension arms attached to the uprights thus allowing the uprights to be placed wider apart, without increasing the length of the crossbar.*

18. **Take-Off Box for Pole Vault** - The box shall be constructed of a suitable material sunk level with the surface of the runway, preferably with rounded upper edges. It shall measure 1m in length measured along the inside of the bottom of the box, 60cm in width at the front end and tapering to 15cm in width at the bottom of the stop-board. The length of the box at runway level and the depth of the stop-board are determined by the angle of 105 degrees formed between the base and the stop-board. The base of the box shall slope from runway level at the front end to a vertical distance below ground level of 20cm at the point where it meets the stop-board. The box should be constructed in such a manner that the sides slope outward and end next to the stop-board at an angle of approximately 120 degrees to the base. The box should be painted white. If the box is constructed of wood, the bottom shall be lined with 2.5mm sheet metal for a distance of 80cm from the front of the box. Diagrams showing the construction of the pole vault box appear in Figure 5.

NOTE: *For Youth Athletics provision, see Rule 302.5(k).*

19. **Landing Areas** - Where it is feasible, the landing area for the High Jump should measure not less than 6m long (parallel to the crossbar) by 4m wide; for the Pole Vault it should measure not less than 6.15m long (perpendicular to the crossbar) by 6m wide. There shall be a minimum of 5 m of landing surface behind the box. The landing area for the High Jump and Pole Vault should be composed of soft material other than sawdust or shavings of such composition and construction to provide a soft landing. A front pad, similar in material and dimensions to the landing area, may be used to cover the area surrounding the take-off box of the Pole Vault and extending between the standards. In the High Jump, the landing area should be a minimum height of .712m (28 in.); in the Pole Vault, it should be a minimum height of .813m (32 in.) above the take-off. The side of the landing area nearest to the box shall be placed 10-15cm from the box and shall, when possible, slope away from the box at an angle at least 45 and no more than 48 degrees. Installations prior to January 1, 2020 may have a reduced slope. The exposed area to the sides and back of the vault box shall have suitable padding.

RULE 182 HIGH JUMP

1. The uprights or posts shall not be moved during the competition unless the Referee considers that the take-off or landing pit has become unsuitable. In such a case the change shall be made only after a round has been completed.
2. The competitor must take off from one foot.
3. A competitor fails if:
 - (a) After the jump, the bar does not remain on the supports because of the action of the competitor while jumping, or
 - (b) The competitor touches the ground, including the landing area beyond the vertical plane through the edge of the crossbar nearest to the take-off area, either between or outside the uprights, with any part of the body, without first clearing the bar. If the jumper's foot touches beyond the plane of the uprights while completing a jump, the jump should not be ruled a failure for this reason if no advantage was thereby gained (e.g., the jumper did not use the landing area as a spring device).
 - (c) The competitor touches the crossbar or the vertical section of the uprights when running up without jumping.

- (d) During or after the jump, the competitor deliberately steadies or replaces the bar.
NOTE: *For specifications of High Jump shoes, see Rule 143.3.*

RULE 183 POLE VAULT

1. (a) Where the standards permit, a competitor may have the uprights or supports moved back, but they may not be moved in the direction of the running or runway, and they may not be moved more than 80cm toward the landing area, from the prolongation of the position of the inside edge of the top of the stop-board.

NOTE: *For Youth Athletics exception see Rule 302.5(l).*

- (b) Before the competition starts, each vaulter shall inform the official responsible for the event what position of the uprights or supports he or she wants to use, and this information should be recorded on the score sheet. Any competitor who wants to make any changes should immediately inform the official responsible before the uprights have been set in accordance with the initial wishes. After confirmation of the position of the uprights and the time for the trial has started, no further change in the position of the uprights is allowed. See Rule 180.12(g).
2. The take-off shall be from a box made of wood, metal, or other suitable rigid material. The box shall be sunk level with the runway.
3. In order to obtain a better grip, competitors are permitted to use a substance on their hands or on the pole during the competition. Gloves may be used. The use of a forearm cover to prevent injuries shall be allowed. See Rule 183.8 in regard to the use of tape on pole.
4. Competitors may use their own poles. No competitor may use any of the private poles except with the consent of the owner.
5. It shall be a failure if:
- (a) After the vault, the bar does not remain on the pegs on which it originally rested because of the action of the competitor while vaulting; or
- (b) The vaulter touches the ground, including the landing area beyond the vertical plane of the upper part of the stop-board, with any part of the body or with the pole without first clearing the bar; or
- (c) The vaulter, after leaving the ground, places the lower hand above the upper or moves the upper hand higher on the pole; or
- (d) During the vault, the vaulter steadies or replaces the bar with his/her hand(s).
NOTE 1: *It is not a foul if the vaulter runs outside the white lines marking the runway at any point.*
NOTE 2: *It is not a foul solely because the pole touches the vaulting pad, in the course of an attempt, after properly being planted in the box.*
6. After the release of the pole, no one including the athlete shall be allowed to touch the pole unless it is falling away from the bar or uprights. If it is touched, however, and the official in charge of the Pole Vault is of the opinion that, but for the intervention, the bar would have been knocked off, the vault shall be regarded as a failure.

NOTE: *It is not a failure if the pole passes underneath the cross bar in the event the competitor clears the bar. It is not a failure if a competitor leaves the ground for the purpose of making a vault and fails to clear the bar, provided he/she does not otherwise commit a foul.*

7. If, in making an attempt, the competitor's pole is broken, it shall not be counted as an attempt or a failure and the vaulter shall be awarded a new trial.

NOTE: *For specifications of Vaulting Pole, Landing Pits, Runways, and Apparatus for High Jump and Pole Vault, see Rules 181.10-19.*

8. **Pole Construction** - The pole may be of any material or combination of materials and of any length or diameter, but the basic surface must be smooth. The pole may have layers of tape at the grip end, to protect the hand, and of tape and/or any other suitable material, such as a sleeve, at the bottom end, to protect the pole. Any tape at the grip end must be uniform except for incidental overlapping and must not result in any sudden change in diameter, such as the creation of any 'ring' on the pole.

NOTE: *The pole may be taped in either direction.*

RULE 184

HORIZONTAL JUMPS - GENERAL RULES

TAKE-OFF BOARD

1. The jump or take-off should be from a board.

NOTE 1: *For Youth Athletics specifications see Rule 302.5(d).*

NOTE 2: *For Masters exception see Rule 332.3(k)*

2. The take-off shall be marked by a board sunk level with the runway and the surface of the landing area. The edge of the board which is nearer to the landing area shall be the take-off line.

3. **Construction** - The take-off board shall be rectangular, made of wood or other suitable rigid material in which the spikes of an athlete's shoe will grip and not skid and shall measure 1.22m \pm 0.01m long, 20cm (\pm 2mm) wide and not more than 10cm deep. It shall be white. In order to ensure that the take-off line is clearly distinguishable and in contrast to the take-off board, the ground immediately beyond the take-off line shall be a color other than white.

NOTE: *The take-off board can be constructed as a single piece 0.30m wide with a 0.20m white section and 0.10m in a contrasting color, i.e. the take-off board and blanking board can be one piece.*

4. The use of video or other technology, to assist the Judges in deciding the application of Rule 185.5(a) is recommended at all levels of competition. However, if no technology is available, a plasticine indicator board placed immediately beyond the take-off line may still be used.

5. **Plasticine Indicator Board** - This shall consist of a rigid board, 10cm (\pm 2mm) wide and 1.22m \pm 0.01m long made of wood or any other suitable material and shall be a contrasting color to the take-off board. The board shall be mounted in a recess or shelf in the runway, on the side of the take-off board nearer the landing area. The surface shall rise from the level of the take-off board to a height of 7mm (\pm 1mm). Any recess shall be filled with plasticine such that the surface of the plasticine nearer to the take-off line shall be at an angle of 90 degrees. Where possible, the plasticine should be of a third contrasting color. See Figures 6. When mounted in this recess, the whole assembly shall

be sufficiently rigid to accept the full force of the athlete's foot. The surface of the board beneath the plasticine shall be of a material in which the spikes of an athlete's shoe will grip and not skid. The plasticine can be smoothed by means of a roller or suitably shaped scraper for the purposes of removing the footprints of the competitors.

NOTE 1: *Where in the construction of the runway and/or take-off board there was provision for the placement of a plasticine indicator board and such board is not used, this recess should be filled by a blanking board flush with the take-off board.*

NOTE 2: *When weather conditions dictate, particularly in very hot or wet weather, the plasticine boards should be protected from the elements before they are installed.*

NOTE 3: *It is helpful to have spare plasticine boards available so that competition is not delayed.*

LANDING AREA

6. The landing area shall have a minimum width of 2.75m and a maximum width of 3m. It shall, if possible, be so placed that the middle of the runway, if extended, would coincide with the middle of the landing area.

NOTE: *When the middle of the runway is not in line with the middle of the landing area, a tape, or if necessary, two tapes, should be placed along the landing area so that the above is achieved.*

7. The landing area, to a minimum depth of 30cm, should be filled with soft damp sand, the top surface of which shall be level with the take-off board.

DISTANCE MEASUREMENTS

8. The measurement of each jump shall be made immediately after each valid trial or immediate oral protest from the nearest break in the landing area made by any part of the body of the competitor, or anything that was attached to the body at the time it made the mark, at a right angle to the take-off line or the take-off line extended. The mark in the landing area, for each attempt, shall be preserved until removal is authorized by the Chief Judge for the event.

NOTE: *In order to ensure correct measurement of any jump, it is essential that the surface of the sand in the landing area should be accurately controlled so as to be level with the top of the take-off board. For measurements, see Rule 148.3(b).*

9. **Wind Measurement** - See Rules 163.10 through 163.14 for wind gauge placement, operation and reading requirements.

RULE 185 LONG JUMP

TAKE-OFF BOARD

1. It is recommended that the distance between the take-off board and the end of the landing area shall be at least 10m.
2. The take-off board should be not less than 1m or more than 3m from the landing area.

COMPETITION

3. The length of the run is unlimited. Each competitor shall be credited with the best of all his/her jumps.
4. When leaving the landing area, an athlete's first contact by foot with its border or the ground outside shall be further from the take-off line than the nearest break in the sand.

NOTE: *This first contact is considered leaving.*

5. It shall be counted as a failure or foul if any competitor:
 - (a) While taking off, at any time prior to the instant at which the competitor ceases contact with the take-off board or ground, breaks the vertical plane of the take-off line with any front part of his/her take-off foot or shoe, whether running up without jumping or in the act of jumping; or
NOTE: *It is not a failure if the break of the vertical plane is made by a loose part of the shoe (e.g., shoelace).*
 - (b) Takes off from outside either end of the board, whether beyond or before the extension of the take-off line; or
 - (c) Employs any form of somersaulting whilst running up or in the act of jumping; or
 - (d) After taking off, but before first contact with the landing area, touches the runway or the ground outside the runway or outside the landing area; or
 - (e) In the course of landing, touches the border of or the ground outside the landing area closer to the take-off line than the nearest break made in the sand; or
 - (f) Leaves the landing area in any manner other than that described in Rule 185.4.
6. A competitor shall not be regarded to have failed if:
 - (a) He or she runs outside the white lines marking the runway at any point; or
 - (b) Under Rule 185.5(b) a part of his/her shoe / foot is touching the ground outside either end of the take-off board, before the take-off line; or
 - (c) If in the course of landing, he or she touches, with any part of his body, or anything attached to it at that moment, the ground outside the landing area, unless such contact contravenes Rule 185.5(d) or (e); or
 - (d) He or she walks back through the landing area after having left the landing area in the manner described in Rule 185.4; or
 - (e) Except as described in Rule 185.5(b), he takes off before reaching the board.

RULE 186
TRIPLE JUMP

1. Rule 184 and Rule 185 shall apply to the Triple Jump with the following variation.

TAKE-OFF BOARD / AREA

2. The distance between the take-off line for men and the far end of the landing area shall be at least 21m.
3. Where necessary for the level of competition, there should be a separate take-off board for men and women. The take-off line shall not be less than 13m for men and 11m for women from the nearer end of the landing area. For any other competition, this distance shall be appropriate for the level of competition.

4. Between the take-off board and the landing area there shall, for the step and jump phases, be a take-off area of $1.22\text{m} \pm 0.01\text{m}$ wide providing firm and uniform footing.

COMPETITION

5. The Triple Jump shall consist of a hop, a step and a jump in that order.
6. The hop shall be made so that an athlete lands first on the same foot as that from which the athlete has taken off, the step shall land on the other foot, from which, subsequently, the jump is performed. It shall not be considered a failure if, during any phase of a trial, an athlete touches the ground with the 'sleeping' leg.
NOTE: *Rule 185.5(d) does not apply to the normal landings from the hop and step phases.*

RULE 187 THROWING EVENTS - GENERAL RULES

1. In all throwing events from a circle, the throw shall commence from a stationary position inside the circle. A competitor is allowed to touch the inside of the iron band or stop-board, excluding the top inside edge. However, it shall be a foul throw if, after commencing the throw and prior to its completion, the competitor:
 - (a) Does not start from a stationary position inside the circle,
NOTE: *The intent of the rule is to negate competitor advantage or momentum from a motion that began outside the circle. There is no restriction on how, or from which direction, an athlete may enter the circle. The relevant requirement is that once inside they must adopt a stationary position before commencing their trial. A stationary position means that a competitor having entered the circle to make their trial, and before doing so, adopts a stance in which both feet are simultaneously in firm contact with the ground inside the circle and with no contact with the top of the rim or the ground outside. Such contact to be sufficiently long in time to be visible to the judges. There is no requirement for the arms or hands or other parts of the competitor's body to be stationary.*
 - (b) Touches with any part of the body the top of the metal band including the top inside edge of the metal band or the surface outside the circle,
NOTE 1: *It will not be considered a failure if the touch occurs during any first rotation at a point completely behind the white line which is drawn outside the circle running, theoretically, through the center of the circle.*
NOTE 2: *It will not be considered a failure if the touch, including of the top of the stop-board, or in the case of the Javelin Throw, the throwing arc or lines marking the runway, is made at any time by a loose part of the shoe, clothing or any other item (e.g., shoelace), or by an item which was attached to the body at the time of the start of the throw and became detached during or after the throw (e.g. jewelry or hat).*
NOTE 3: *For Youth Athletics exception see Rule 302.5(e).*
 - (c) In the Shot Put, touches with any part of the body any part of the stop-board other than its inner side. The top inside edge is considered to be part of the top,
 - (d) Releases the shot or the javelin other than as permitted under Rule 188.2 or Rule 193.1, or
 - (e) Leaves the circle improperly or before the implement has landed.

2. In all throwing events, a competitor who has not otherwise committed a foul may interrupt a trial once started, may lay the implement down, inside or outside the runway or circle, may leave the runway or circle before returning to the runway or to a stationary position in the circle, and begin a fresh trial.

NOTE: *All moves permitted in this Rule shall be included in the maximum time for a trial given in Rule 180.12.*

3. The following shall be considered assistance and are therefore not allowed:
- (a) The taping of two or more fingers together. If taping is used on the hands and fingers, it may be continuous provided that as a result no two or more fingers are taped together in such a way that the fingers cannot move individually. The taping should be shown to the Chief Judge before the event starts.
 - (b) The use of any device of any kind, including weights attached to the body, which in any way provides assistance when making a trial.
 - (c) The use of gloves except in the Hammer and Weight Throw. In this case, the gloves shall be smooth on the back and on the front and the tips of the glove fingers, other than the thumb, shall be open.
 - (d) The spraying or spreading of any substance, by an athlete, in the circle or on their shoes or the roughening of the surface of the circle.
NOTE: *The placement, by a competitor, of tape to the outside of a throwing shoe is acceptable, and shall be shown to the Chief Judge.*
 - (f) In the Javelin Throw, the placement of chalk or a similar substance on the implement by a competitor.

4. The following shall not be considered assistance and are therefore allowed:
- (a) The use by an athlete, in order to obtain a better grip, of a suitable substance on his hands only or in the case of a hammer thrower or weight thrower on his/her gloves.

In the Shot Put and Discus Throw, the placement of chalk or a similar substance on the implement by an athlete. A shot putter may use such substances on their neck.

All substances used on the hands, gloves and on the implements shall be easily removable from the implement using a wet cloth and shall not leave any residue.

- (b) The use of taping on the hands and fingers that is not in contravention of Rule 187.3(a).

NOTE: *If the Judges are aware, they shall direct any athlete not complying with this Rule to correct the situation. If the athlete does not, such trial(s) shall be a failure. It shall also be judged as a failure, if a trial is completed before the non-compliance is noticed.*

5. The competitor must not leave the circle until the implement has touched the landing surface. When leaving the circle, the competitor's first point of contact with the top of the iron band and/or the surface outside the circle must be completely behind the white line that is drawn outside the circle running theoretically through the center of the circle. The first contact with the top of the iron band or the ground outside the circle is considered leaving.

6. It shall be a failure if the head of the javelin or the implement in the Shot Put, Hammer Throw, Weight Throw and Discus Throw, excluding the handle, wire and connections as appropriate, in contacting the ground when it first lands touches the sector line or the ground outside the sector line. Moreover, it shall be a failure if the shot, the discus, the hammer head or the head of the javelin after the release but before contacting the ground touches any object outside the sector line except as provided in the Note. See Rules 187.22 and 187.24 for sector description.
- NOTE:** *It shall be considered a failure if the discus or the head of the hammer strikes the far side of the cage (left side for a right-handed thrower, right side for a left-handed thrower when facing the landing sector) after the release of the implement. It will not be considered a failure if the discus or any part of the hammer strikes the near side of the cage (right side for a right-handed thrower, left side for a left-handed thrower when facing the landing sector) after the release of the implement, then lands within the landing sector outside the limits of the cage, provided that no other Rule is infringed.*
7. The measurement of each throw shall be made immediately after each valid trial or immediate oral protest. The mark in the landing area, for all attempts, shall be preserved until removal is authorized by the official responsible for the event.
- (a) In the Discus, Shot Put, Weight Throw and Hammer Throw, the measurement of each throw shall be made from the nearest mark made by the fall of the discus, shot, weight, or head of the hammer to the inside of the circumference of the circle along a line from the mark to the center of the circle.
- (b) In the Javelin Throw, the measurement of each throw shall be made from where the metal head first struck the ground to the inside edge of the arc along a line from the point of the fall to the center of the circle of which the arc is a part.
- NOTE:** *For Youth Athletics exception see Rule 302.5(h).*
8. Implements must be carried back to the runway or circle and never thrown back.
9. All Hammer, Discus, and Weight Throws shall be from an enclosure or cage to ensure the safety of spectators, officials, and competitors. See Rule 190.
- NOTE:** *For specifications of official implements, see Rules 188-195. For specifications of circle, see Rule 187.18-187.20.*
10. In all throwing event competitions, Championship and non-championship, implements should be provided by the Games Committee. However, implements that comply with required specifications and belong to individuals may also be accepted by the Games Committee as implements provided by it. And as so accepted, they shall lose their identity as privately owned implements for the duration of the competition and no modification may be made to these implements during the competition. Unless specified by the Games Committee in the entry material/Technical Information, not more than two implements may be submitted by a competitor for any throwing event in which he/she is competing. No additional implements may be taken to the area for competition or practice.
- NOTE 1:** *The Games Committee shall establish a reasonable schedule for checking implements to ensure a fair and timely competition.*
- NOTE 2:** *For Youth Athletics exception see Rule 302.5(g). For Masters exception see Rule 332.3(h).*
11. If an implement does not comply with required specifications, or if it has not been properly certified for use when such certification is required, it should be impounded

by the certifying official or the Chief Judge of the event until the end of the competition of the field event in which it was intended to be used.

12. If, as a result of material damage, an implement becomes a safety hazard or if it ceases to comply with specifications (e.g., a loose point or a cut hammer wire), it should be impounded. If it is practicable to do so, it should be repaired and re-certified so that it may be used in the competition. If the implement cannot readily be repaired, it shall remain impounded until the conclusion of the competition, except that it may be returned to a competitor who has concluded throwing.
13. A competitor in a field event shall be disqualified if he/she uses an implement or equipment that has been illegally altered after having been officially inspected or if he/she uses an unapproved or illegal implement or equipment. No spitting or application by other means of human body fluids on any implement is permitted. The presence of perspiration shall not be prohibited. All records, performances, or points scored with the use of such implement or equipment shall be null and void.
14. In the case of an American or World Record, the implement should be impounded and not used until it has been re-certified for the record.
15. **Landing Area** - The landing area for outdoor throwing events shall consist of suitable material with an even surface soft enough to ensure that the place of the initial imprint of the implement can be clearly established by the judges. These areas shall be on natural surfaces, which shall not be laid down on concrete, asphalt, wood or other hard surfaces that would have the tendency to decrease the landing surface's absorption of the kinetic energy of the implement.
16. **Inclination of the Sector** - The area within the sector on which the implement lands shall be on approximately the same plane as that of the circle or runway with a maximum downward allowance of 1:1000 in the throwing direction when measured from the level of the center of the circle or the level of the center of the throwing arc.
17. **Sector Flags**
 - (a) **Construction** - Sector flags should be entirely of metal.
 - (b) **Measurements** - The flags should be rectangular in shape, measuring about 20x40cm with the standard 8mm in diameter and not less than 60cm in height above the ground.

FOR THROWS FROM A CIRCLE

18. **Construction** - The rim of the circle shall be made of a band of iron, steel or other suitable material, the top of which shall be sunk flush with the ground outside the circle. The inside and top of the rim shall be white. The ground surrounding the circle may be concrete, synthetic, asphalt, wood or any other suitable material. The interior of the circle may be constructed of concrete, asphalt or some other firm but not slippery material. The surface of the interior shall be level and 2cm (\pm 6mm) lower than the upper edge of the rim of the circle. In the Shot Put, a portable circle meeting these specifications, including wood, is permissible.
19. **Circle Marking** - A line 5cm wide shall be drawn theoretically through the center of the circle, extended no less than 75cm on each side, to designate the front and rear halves of the circle. The extensions outside the circle should be marked on the ground, but the line should not be marked in the circle. See diagrams, Figure 8.

20. **Dimensions** - The metal circle shall be 6mm thick and 76mm high sunk flush with the ground outside. The inside diameter of the circle shall measure 2.135m (7 ft.) for the Shot Put, Weight Throws, and Hammer Throw, and 2.50m for the Discus Throw.
21. **Shot Put Stop-Board** - The stop-board shall be made of wood or other suitable material in the shape of an arc so that the inner surface aligns with the inner edge of the rim of the circle and is perpendicular to the surface of the circle. The stop-board shall be centered midway between the sector lines, and be so made that it can be firmly fixed to the ground. The board shall measure not less than 11.2cm wide, and have a chord between the ends of the board of 1.15m to 1.21m (± 0.01 m) in length. The board shall be 10cm (± 8 mm) high in relation to the level of the inside of the circle adjacent to the stop-board. The board shall be painted white. A diagram showing the layout of the Shot circle appears in Figure 9.
22. **Sector** - The sector within which all throws from a circle must fall shall be clearly marked on the ground with lines 5cm wide, the inner edges of which shall form the sector boundary. These sector lines are radii from the center of the circle. The outer ends of the radii should be marked with flags. Sectors shall be 34.92 degrees (± 0.1 degree).
- NOTE 1:** *Flags or continuous barriers should be erected parallel to and at least 3m outside of the sector lines for their full length.*
- NOTE 2:** *For description of the landing sector for indoor competitions and exception with limited space indoors, see Rule 221.*

As an aid in marking and checking the 34.92-degree sector lines, the table below may be used. For greater accuracy, use the longest distance the field will allow. In this table, 'A' indicates the distance from the center of the circle to a point on each of the two sector lines and 'B' indicates the distance between those two points.

A in meters	B in meters
5.00	3.00
10.00	6.00
15.00	9.00
20.00	12.00
25.00	15.00
50.00	30.00
75.00	45.00
100.00	60.00

FOR THE JAVELIN THROW

23. **Arc** - All javelin throws shall be made from an arc of a circle drawn with a radius of 8m at the end of a runway 4m wide. This arc shall consist of a painted stripe or made of wood or other similar material, but not metal, at least 7cm in width. It shall be white and sunk flush with the ground. Lines shall be drawn from the extremities of the arc at right angles to the parallel lines marking the runway. These lines should be 75cm in length, from the inner edge of the runway line, and at least 7cm in width.
24. **Sector** - The landing sector shall be marked with white lines 5cm wide such that the inner edges of the lines, if extended, would pass through the two intersections of the inner edges of the arc and the parallel lines marking the runway, and intersect at the center of the circle (A), of which the arc is part. See Figure 11. The end of the sectors may be marked by flags.

NOTE: *Flags or continuous barriers should be erected parallel to and at least 3m outside of the sector lines for their full length*

The sector for the javelin can be laid out by making the distance between two points along the sector lines which are equidistant from the center of the arc described in Rule 187.23, one-half the distance from the center of the arc to the point on the sector line. In the table below, 'A' indicates the distance from the center of the arc to a point on each of the two sector lines and 'B' indicates the distance between those two points with a tolerance of $\pm 0.05\text{m}$.

A in meters	B in meters
8.00	4.00
20.00	10.00
40.00	20.00
50.00	25.00
60.00	30.00
75.00	37.50
100.00	50.00

RULE 188 PUTTING THE SHOT

- The put shall be made from a circle of which the inside diameter shall measure 2.135m (7 ft.).
- The shot shall be put from the shoulder with one hand only. At the time the competitor takes a stance in the ring to commence a put, the shot shall touch or be in close proximity to the neck or chin, and the hand shall not be dropped below this position during the act of putting. The shot must not at any time be brought behind the line of the shoulders. Cart wheeling techniques are not permitted.

NOTE: *For measurement, see Rule 148.3(b)i, and 187.9(a). For details of competition, see Rules 180 and 187. For specifications of circle, stop-board, and sectors, see Rules 187.18-187.22.*

- Construction** - The shot shall be a solid sphere of iron, brass, or any metal not softer than brass, or a shell of such metal filled with lead or other material. If a filling is used, it shall be inserted in such a manner that it is immovable and complies with the requirements for the center of gravity as defined in Rule 191.5. It must be spherical in shape, its surface shall have no roughness, and the finish shall be smooth.

Information for manufacturers only: To be smooth, the surface average height must be less than or equal to $1.6\mu\text{m}$, i.e., a roughness number N7 or less.

NOTE 1: *For exceptions for Indoor shot construction see Rule 222.5*

NOTE 2: *Indentations due to a weight stamp on cast shots or engraving of weight or size should not normally be considered reason for the disqualification of a shot for roughness or hand hold.*

- The shot shall conform to the following weights and dimensions:

Name	16 lb	6 kg	12 lb	5 kg	4 kg	3 kg	6 lb	2 kg
Nominal Wt. kg	7.26	6.00	5.45	5.00	4.00	3.00	2.72	2.00
Record Wt. Min. kg	7.260	6.000	5.443	5.000	4.000	3.000	2.720	2.000
Diameter min. mm	110	105	98.4	100	95	85	-	80
Diameter max. mm	130	125*	117.5	120*	110*	110*	-	90

** The maximum diameter for outdoor shots used in Masters competition shall be 110mm for 2kg and 130mm for 3kg and above.*
NOTE: *The weights and dimensions for implements used by Masters competitors are those adopted by WMA.*

RULE 189 THROWING THE DISCUS

1. The discus shall be thrown from a circle of which the inside diameter shall measure 2.50m.

NOTE: *For details of competition, see Rules 180 and 187. For specifications of circle and sectors see Rules 187.18-20 and Rule 187.22. For throwing cage specification see Rule 190. For measurement, see Rules 148.3(b)i, 187.7(a).*

2. **Construction**

- (a) The body of the discus may be solid or hollow and shall be made of wood or other suitable material, with a metal rim, the edge of which shall be rounded into a true circle having a radius of approximately 6mm. There may be metal plates set flush into the center of the sides. The plates shall be tightly fixed and not be able to rotate. In the alternative, the discus may be made without metal plates, provided that the measurements and total weight of the implement correspond to the specifications. There shall be no loose parts.

- (b) Each side of the discus shall be identical and shall be made without indentations, projecting, or sharp edges. The sides shall taper in a straight line from any point on a circle of a radius, or 25mm to 28.5mm from the center of the discus, to the beginning of the curve of the rim.

- (c) The discus, including the surface of the rim, shall have no roughness and the finish shall be smooth and uniform throughout. The sides and rim of the discus shall be intact, showing no signs of significant cracks, gouges or breakage that would reduce the integrity of the side or discus as a whole or provide the athlete with an improved grip.

3. The discus shall conform to the following weights and dimensions: (See Figure 10)

Name	2kg	1.75kg	1.6kg	1.5kg	1 kg	0.75kg
Nominal Wt. kg	2.0	1.75	1.6	1.5	1.0	0.75
Minimum Record Wt. kg	2.000	1.750	1.600	1.500	1.000	0.750
Outside Diameter min. mm	219	210	209	200	180	166
Outside Diameter max. mm	221	212	211	202	182	182
Diameter of Flat Area min. mm	50	50	50	50	50	50
Diameter of Flat Area max. mm	57	57	57	57	57	57
Thickness at center min. mm	44	41	40	38	37	33
Thickness at center max. mm	46	43	42	40	39	39
Thickness of Rim at 6 mm from edge, min. mm	12	12	12	12	12	10
Thickness of Rim at 6mm from edge, max. mm	13	13	13	13	13	13

NOTE: *The weights and dimensions for implements used by Masters competitors are those adopted by WMA.*

RULE 190 HAMMER, DISCUS, AND WEIGHT THROWING CAGE

It is required that all Hammer, Weight, Superweight, and Discus Throws be from an enclosure or cage to ensure the safety of spectators, officials, and competitors. The cage specified in this rule is intended for use in a major stadium when the event takes place outside the arena with spectators present or when the event takes place in the arena with other events taking place at the same time. Where this does not apply, a simpler construction may be satisfactory, provided it ensures safety. See Figures 12-13, and World Athletics Rules 190 and 192, for suggested specifications of cages for the Hammer and Discus.

NOTE 1: *An effective hammer cage should have moveable panels at the front where the operative positions of these panels are marked, either permanently or temporarily, on the ground. These should be constructed so that the inside edge of either panel can be moved to a point 1.5m inside the sector line. If the panels are too short to reach 1.5m inside the sector, then set it for the maximum distance in the sector. There are two options at this point.*

- (a) *This setup corresponds to using an existing pre-2007 NCAA cage. See Figure 13. The support to which these movable panels are attached should be no closer than 2.85m outside the sector line or about 6.1m from the center of the circle). Each of the movable panels should be at least 4.35m in width. The height of the movable panels and at least the first stationary panels should be 6.15m. The netting for the cage panels should be suspended and not tied tightly in order to absorb the impact of the Hammer and reduce the risk of the Hammer rebounding. The opening should be 6m wide, measured from the inner edge of the cage or pivoted netting as appropriate, and positioned 7m in front of the center of the throwing circle. However, the width of opening at the front of the cage is less critical than where the opening is placed. Thus, the distance of the panels from the center of the circle is important. The panels are alternated for left- and right-handed throwers. The panel opposite to the direction of spin, i.e., the left-hand panel, for a right-handed thrower, is placed inside the sector line 1.5m. If shorter than this distance, then the gate should be perpendicular to the sector line. The end of the other gate should be about 1.1m off the sector line.*

- (b) *An alternate cage is the World Athletics cage and is recommended for new construction. See Figure 12.*

NOTE 2: *The cage side, particularly alongside the track, may be lengthened with the use of movable panel(s) and/or increased in height to provide greater protection to athletes competing on the adjoining track during a discus competition.*

RULE 191 THROWING THE HAMMER

1. The competitor in the starting position, prior to the preliminary swings or turns, is permitted to rest the head of the hammer on the ground inside or outside the circle. In making a throw, the competitor may choose to assume any starting position and shall use both hands, holding the hammer exclusively by the handle.
2. It shall not be considered a foul throw if the head of the hammer touches the ground or the top of the iron band.
3. If the hammer breaks during the throw or while in the air, it shall not count as a throw provided it was made in accordance with the rules. In the event that the competitor

thereby loses balance and commits a foul, it shall not be charged and the athlete shall be awarded a new trial.

4. **Construction** - The hammer shall consist of three parts: a metal head, a wire and a handle.
5. **Head** - The head shall be solid iron or other metal not softer than brass, or a shell of such metal filled with lead or other solid material so that no internal movement is detected by feel, sight or sound. It must be spherical in shape and smooth. If a filling is used, it must be inserted in such a manner that it is immovable and that the center of gravity shall not be more than 6mm from the center of the sphere, *i.e.*, it must be possible to balance the head, less wire and handle, on a horizontal sharp-edged orifice 12mm in diameter.
6. **Wire** - The wire shall be a single unbroken and straight length of spring wire not less than 3mm, and shall be such that it cannot stretch appreciably while being thrown. The wire may be looped at one or both ends as a means of attachment.
NOTE: *A small section of clear vinyl tubing, up to 50mm long with an internal diameter of 5mm, may be placed over the twisted end of the hammer wire to reduce the chance of the implement becoming caught in the cage netting. Clear plastic is required.*
7. **Handle** - The handle shall have a symmetric design, be rigid and without hinging joints of any kind, may have a curved or straight grip and/or brace. Per World Athletics specifications, the minimum handle breaking strength shall be 8kN (800kgf) and the handle shall be designed such that the total deformation of the handle under a tension load of 3.8kN shall not exceed 3mm. See Figure 14.
8. **Connection** - The wire shall be connected to the head by means of a swivel which may be either plain or ball bearing. The handle shall be connected to the wire by means of a loop in such a manner that it cannot be turned within the loop of the wire to increase the overall length of the hammer. A swivel may not be used.

9. The hammer shall conform to the following weights and dimensions:

Name	16 lb	6 kg	12 lb	5 kg	4 kg	3 kg	2 kg
Nominal Wt. kg	7.26	6.00	5.45	5.00	4.00	3.00	2.00
Min. Record Wt. kg	7.260	6.000	5.443	5.000	4.000	3.000	2.000
Diameter min. mm	110	105	98.4	100	95	85	75
Diameter max. mm	130	125	117.5	120	110	100	100
Length max. mm	1215	1215	1215	1200	1195	1195	1195

NOTE 1: *Length of Hammer is measured from the inside of the handle to the bottom of the ball. Pressure should be applied to make sure the wire is straight.*

NOTE 2: *The weight of the implement includes the totality of the hammer head, wire and handle.*

NOTE 3: *The weights and dimensions for implements used by Masters competitors are those adopted by WMA.*

RULE 193

THROWING THE JAVELIN

1. Requirements for a valid throw:
 - (a) The javelin shall be held by the grip with one hand only, so that the little finger is nearest to the point and the thrower's last contact with the javelin shall be with

the grip. The javelin shall be thrown over the shoulder or upper part of the throwing arm and shall not be slung or hurled.

- (b) A throw shall be valid only if the metal head strikes the ground before any other part of the javelin.

NOTE: *For Youth Athletics exception see Rule 302.5(h).*

- (c) After the run-up has begun and until the javelin has been thrown, the competitor shall not at any time turn completely around so that his/her back is toward the throwing area.

NOTE: *This rule is intended to avoid rotation as part of the throwing motion or as part of the run-up. This rule does not prevent a competitor who has interrupted an attempt and walks back to initiate another attempt.*

- (d) No throw shall be valid or counted where the competitor touches, with any part of the body, the arc as marked or the lines drawn from the extremities thereof at right angles to the parallel lines, or the ground beyond the arc or such lines.

- (e) Competitors may not in the course of an attempt touch with any part of their body the lines which mark the runway or the ground outside.

- (f) Competitors shall not leave the runway until the javelin has touched the landing surface. When leaving the runway, the competitor's first point of contact with the parallel lines or the surface outside the runway must be completely behind the arc and the lines drawn from its extremities. The first contact with the parallel lines or the surface outside the runway is considered leaving.

A competitor shall also be considered to have left the runway in a valid manner once the implement has touched the ground and the competitor makes contact with or behind an identified line 4m back from the ends of the throwing arc, or if a competitor is already behind such line and inside the runway at the moment the implement touches the ground.

2. If the javelin breaks during a throw or while in the air, it shall not count as a failure, provided the trial was made in accordance with the rules. Nor shall it count as a failure if the competitor thereby loses his/her balance and as a result contravenes any part of this Rule. In both cases, the competitor shall be awarded a replacement trial.

3. If a thrower improperly releases the javelin in making an attempt, it shall be recorded as a foul throw.

NOTE: *For details of competition, see Rules 180 and 187.*

For measurements, see Rules 148.3(b)i, 187.7(b).

For specifications of runway, arc, and sector, See Rules 180.21, 187.23 and 24.

4. **Construction** - The javelin shall consist of three main parts: a head, a shaft, and a cord grip. The shaft may be solid or hollow and shall be constructed of metal or other suitable material so as to constitute a fixed and integrated whole. The shaft shall have fixed to it a metal head terminating in a sharp point. The head shall be constructed completely of metal. It may contain a reinforced tip of other metal alloy fixed to the front end of the head provided that the completed head is smooth and uniform along the whole of its surface. The angle of the tip shall not exceed 40 degrees.

NOTE: *The metal head up to 3mm from the tip may be disregarded for the angle of the point.*

5. The grip, which shall cover the center of gravity, shall not exceed the average diameter of the shaft by more than 8mm. It may have a regular non-slip pattern surface but without thongs, notches, or indentations of any kind. The grip shall be of uniform thickness.

6. The javelin shall conform to the following weights and dimensions:

Name	800g	700g	600g	500g	400g
Nominal Wt. G	800	700	600	500	400
Minimum Record Wt. G	800	700	600	500	400
Overall Length min. mm	2600	2400	2200	2000	1850
Overall Length max. mm	2700	2500	2300	2100	1950
Length-Metal Head min. mm	250	250	250	220	200
Length-metal head max. mm	330	330	330	270	250
Dist. From tip to CG min. mm	900	850	800	780	750
Dist. From tip to CG max mm	1060	990	920	880	800
Diameter of Shaft					
at thickest point min. mm	25	23	20	20	20
Diameter of Shaft					
at thickest point max. mm	30	28	25	24	23
Width of cord grip, min. mm	150	150	140	135	130
Width of cord grip max. mm	160	160	150	145	140
Taper Meas. from Tip mm	150	150	150	150	125
Taper Meas. from Tail mm	150	150	150	150	125
Diameter at Tip Taper					
Measurement Point	≤0.80dia*	≤0.80dia	≤0.80dia	≤0.80dia	≤0.80dia
Diameter at Tail Taper					
Measurement Point	≥0.40dia	≥0.40dia	≥0.40dia	≥0.40dia	≥0.40dia
Diam. at Midpoint Tip to CG	≤0.90dia	≤0.90dia	≤0.90dia	≤0.90dia	≤0.90dia
Diam. at Midpoint Tail to CG	≥0.90dia	≥0.90dia	≥0.90dia	≥0.90dia	≥0.90dia
Tail Diameter min mm	3.5	3.5	3.5	3.5	3.5

* dia. is the maximum diameter for the implement.

NOTE 1: *The weights and dimensions for implements used by Masters competitors are those adopted by WMA.*

7. The cross-section shall be regularly circular throughout (see Note 1). The maximum diameter of the shaft shall be immediately in front of the grip. The central portion of the shaft, including the part under the grip, may be cylindrical or slightly tapered toward the rear, but in no case may the reduction in diameter, from immediately in front of the grip to immediately behind, exceed 0.25mm. From the grip, the javelin shall taper regularly to the tip at the front and the tail at the rear. The longitudinal profile from the grip to the front tip and the tail shall be straight or slightly convex (see Note 2), and there must be no abrupt alteration in the overall diameter, except immediately behind the head and at the front and rear of the grip, throughout the length of the javelin. At the rear of the head, the reduction in the diameter may not exceed 2.5mm and this departure from the longitudinal profile requirement may not extend more than 30cm behind the head.

NOTE 1: *While the cross-section throughout should be circular, a maximum difference between the largest and the smallest diameter at any cross-section of 2% is permitted. The mean value of these two diameters at any selected cross section must correspond to the specification of a circular javelin.*

NOTE 2: *The shape of the longitudinal profile may be quickly and easily checked using a metal straightedge at least 50cm long and two feeler gauges 0.20mm and 1.25mm thick. For slightly convex sections of the profile, the straightedge will rock while being in firm contact with a short section of the javelin. For straight sections of the profile, with the straightedge held firmly against it, it must be impossible to insert the 0.20mm gauge between the Javelin and the straightedge anywhere over the length of contact. This shall not apply immediately behind the joint between the head and the shaft. At this point it must be impossible to insert the 1.25mm gauge.*

8. The javelin shall have no mobile parts or other apparatus that, during the throw, could change its center of gravity or throwing characteristics.
9. The surface of the shaft shall have no dimples or pimples, grooves or ridges, holes or roughness, and the finish shall be smooth and uniform throughout. To be smooth, the surface average height must be less than 1.6µm (a roughness number of N7 or less). Tape or any other substances shall not be placed on the javelin. The head shall be constructed completely of metal. It may contain a reinforced tip of other metal alloy welded on to the front end of the head, maximum 40 degrees, provided that the completed head is smooth and uniform along the whole of its surface.
10. **Mini Javelin** - The shaft, grip and fins shall be made out of plastic. The tip shall be made of soft rubber with a blunt, rounded end. The fins shall be flat (without protrusions or roughness) and shall be perpendicular to the surface of the javelin. The fins shall be parallel to the center line of the shaft. The nominal weights shall be 300g, 400g, 500g and 600g. All shall conform to the following specifications, as applicable:

300g and 400g Mini Javelin Specifications (All dimensions in mm):

Dimension	Min	Max
Overall Length	685	705
Length of head	84	94
Tip Diameter at largest point	37	43
Distance from Tip to CG	365	380
Diameter of shaft forward of grip	30	38
Diameter of shaft behind the grip	24	30
Diameter of shaft at the grip	34	40
Length of grip	99	109
Location of front of grip from tip of tail	322	332
Fin length	162	168
Fin Diameter (peak to peak opposing fins)	95	105
Number of Fins	4	4

500g and 600g Mini Javelin Specifications (All dimensions in mm):

Dimension	Min	Max
Overall Length	1100	1140
Length of head	85	95
Tip Diameter at largest point	35	45
Distance from Tip to CG	560	610
Diameter of shaft forward of grip	30	38
Diameter of shaft behind the grip	31	37
Diameter of shaft at the grip	40	45
Length of grip	105	125
Location of front of grip from tip of tail	550	570

Fin length min.	165	175
Fin Diameter (peak to peak opposing fins)	85	95
Number of Fins	4	4

11. **Aero Javelin** – The shaft, tip and tail shall be made out of synthetic material. The grip may be made of synthetic material or wound with cord which is similar to that used on traditional javelins. The nominal weights shall be 250g or 450g. The diameter of the shaft shall be constant over the length of the shaft, not varying by more than ± 2 mm from the nominal shaft diameter. The profiles of the head and tail are not specified. See Figure 17.

Aero Javelin 450g Specifications (All dimensions in mm):

Dimension	Min	Max
Overall Length	1765	1785
Length of head *	140	160
Distance from Tip to CG **	760	770
Diameter of shaft	20	28
Length of grip ***	115	120
Location of front of grip from tip	755	770
Length of tail	175	195

Aero Javelin 250g Specifications (All dimensions in mm):

Dimension	Min	Max
Overall Length	1350	1480
Length of head *	140	160
Distance from Tip to CG **	570	600
Diameter of shaft	24	26
Length of grip ***	80	110
Location of front of grip from tip	570	610
Length of tail	105	120

* The maximum diameter of the head shall not exceed the nominal shaft diameter by more than 10 mm.

** The grip is not required to cover the CG.

*** The maximum grip diameter shall not exceed the nominal shaft diameter by more than 8 mm.

RULE 195 THROWING THE WEIGHT

1. In making a throw, the competitor may choose to assume any starting position, holding the weight exclusively by the handle, and using both hands except at the start of the throw and at the release of the implement.
2. In all other respects, the rules for the Hammer Throw (Rule 191) shall govern.
3. **Construction** - The weight shall consist of three parts: a head (ball), a handle, and a connection assembly which may contain a harness.
4. **Head** -

- (a) **All Metal Head** - The head shall be a sphere. The head shall be made of solid metal not softer than brass. There shall not be any internal movement. The center of gravity shall not be more than 9mm from the center of the sphere.
- (b) **Filled Head** - The head shall be a shell made of plastic or other suitable polymer material in the shape of a sphere, designed to protect the landing surface. The head shall be filled with lead or other material inserted in a manner that minimizes any internal void or movement and have center of gravity not more than 9 mm from the center of the sphere certified by the manufacturer. The head may deform upon impact but must return to the shape of a sphere.

NOTE: *Rubber is not an acceptable material for the shell.*

5. **Handle** - The handle shall be made of round steel metal rod, bent in a triangular shape with straight sides. The handle may include an internal brace or loop. The handle must be rigid and not show evidence of elasticity or malformation before, during or after the competition. Hammer handles are not allowed. See Figure 15.

- (a) The handle for the filled head weight shall have sides that do not exceed 160 mm or are not smaller than 100mm inside measurement. A handle with no permanent connection point shall have all three sides of equal length.
- (b) The handle for the all-metal head weight shall have sides that do not exceed 190 mm or smaller than 100 mm inside measurement. A handle with no permanent connection point shall be constructed in such a manner that regardless of how the handle is turned the length of the implement does not exceed the specified maximum length of the implement.

6. **Harness** - If the implement includes a harness, it shall be fabricated from a minimum of four straps sewn together to form a sling. Netting shall not be used for this purpose. The harness must not stretch or show evidence of elasticity or malformation before, during or after the competition. A protective sleeve may be used around the links and/or swivel.

7. **Connection** - The handle shall be connected to the head or to a harness in the following manner:

- (a) After the handle, by means of no more than two steel links (loops), whose size shall be such that they cannot stretch while the implement is being thrown.

NOTE: *Wire is not a suitable connector.*

- (b) For the All Metal Head, the links may be connected to the head by means of a swivel, which may be either plain or ball bearing, and is not considered an additional link. A swivel shall not be used to connect the handle to the link(s).
- (c) For a Filled Head or Harness, the use of links and swivel are optional. However, at least one shall be used and when used in combination, the swivel shall be attached to the head.

- (d) A protective sleeve may be used around the links and/or swivel.

8. **Length** - The maximum overall length of the complete implement as thrown, measured from the bottom of the complete implement with its head in its spherical shape, to the inside surface of the middle of the handle (grip) shall not exceed 410.0mm at any time.

NOTE: An implement presented for inspection must be measured for length with all components at their maximum lengths as designed by the manufacturer. Once the implement has been inspected and approved for competition, the implement shall not be altered or adjusted other than to be repaired by the Inspector of Implements.

9. The weight shall conform to the following weights and dimensions:

Name	56 lb	20 kg	35 lb	25 lb	20 lb	16 lb	12 lb	4 kg
Nominal Weight kg	25.40	20.00	15.88	11.34	9.08	7.26	5.45	4.00
Min Record Weight kg	25.40	20.00	15.88	11.34	9.08	7.26	5.45	4.00
Diameter min. mm			145	130	120	110	100	95
Diameter max. mm			165	150	140	130	120	110
Diameter Masters Indoor max. mm			180	165	155	145	135	110

NOTE 1: Except for the 4kg implement, the maximum diameter for indoor implements is 15 mm larger.

NOTE 2: The construction, weights and dimensions for implements used by Masters competitors are those adopted by WMA.

RULE 196 THE ULTRAWEIGHT

1. **Construction** - The Ultraweight shall consist of three parts: a main body, a handle, and a connection assembly
2. **Main Body** - The main body should be either a solid cylinder or constructed of no more than two solid cylinders (200 lb weight) or three solid cylinders (300 lb weight) stacked and held together so as to form an essentially solid cylinder.
 - (a) The cylinder shall be made of a material no softer than lead. An outer casing, such as a steel pipe, may be used, provided the length and diameter specifications are maintained.
 - (b) The diameter of the cylinder shall not exceed 26.7cm nor be less than 15.25cm.
3. **Handle** - The handle shall be made of a round steel rod, not less than 12mm in diameter, bent in a triangular or modified triangular shape so that no side exceeds 20cm inside dimension. A handle shall have two sides of equal length and the third side (handle) of more than or equal length. When the overall length of the implement is measured, the equal sides must form the sides of the triangle. The handle must be rigid and not show evidence of elasticity or malformation after being thrown.
4. **Connection Assembly** - The main body shall incorporate a permanent eye bolt, u-bolt or shackle in its construction (stainless steel recommended), which may swivel. The handle should be connected by means of a removable shackle or link(s) (stainless steel recommended). No more than two links shall be used, in addition to the handle anchor shackle and the main body connection. An immovable handle is not recommended.
5. **Length** - The overall length of the complete implement, from the inside surface of the handle (grip) to the bottom surface of the main body to shall not exceed 45.75cm.

6. **Weight Specifications** - In addition to the Weight implement specification found in Rule 195, the Ultraweight implement shall conform to the following:

Implement	98 lb	200 lb	300lb
Minimum Weight - kg	44.50	90.80	136.10

Since most official's organizations will not have a scale of sufficient capacity to weigh these implements, the event management should make arrangements to have the implements weighed prior to the event by an outside source. Weighing services should be sought from an establishment that can prove its scale's calibration is traceable to NIST, and the measurement accuracy is no greater than ± 50 grams.

A certificate attesting to the calibration of the scales used and exact weight of the implements being used in a competition must be presented to the Inspector of Implements prior to the start of competition.

7. **Throwing Area** - The following apply for the 98, 200 and 300 lb implements.
- (a) **Construction** - The Ultraweight shall be thrown from a square that is made of bands of iron, steel or other suitable material, and painted white. The surface of the square may be sunk flush with the surrounding ground or installed on top of the ground; the latter case being allowed for ease of transportation and storage of the hardware, as well as providing the ability to assemble the square so the front side is even with the edge of the concrete or other slab. If it is installed on the surface of the ground, provisions should be made that allow securing of the square to eliminate movement for the duration of the competition.

The surface surrounding the square may be concrete, synthetic, asphalt, wood or any other suitable material. The surface within the square shall be constructed of concrete or similar material. The throwing field shall be level with the surface within the square.

- (b) **Dimensions** - The inside dimensions of the square shall measure 2.135m on each side. The square bands shall be 5cm wide. The top surface of the square bands shall be 20mm above the surrounding ground. However, the width of the bands may be increased if this assists in bolting or otherwise fastening the square to the ground.
- (c) **Projection lines** - A line 5cm wide shall be drawn theoretically through the center of the square, extended no less than 75cm on each side, to designate the front and rear halves of the square. The extensions outside the square should be marked on the ground, but the line should not be marked inside the square.
- (d) **Sector** - The sector within which all throws from the square must fall shall be clearly marked on the ground with lines 5cm wide, the inner edges of which shall form the sector boundary. These sector lines are extensions of the sides of the throwing square.

NOTE: Further material regarding Ultraweight specifications and illustrations of the implement, throwing area and landing sector can be found in the Officials Manual for the Ultraweight Pentathlon. See Rule 203 for competition rules.

**SECTION IV
COMBINED EVENTS**

**RULE 200
EVENTS - GENERAL RULES**

1. Competition for men:

- (a) The Outdoor Pentathlon, which shall be conducted on one day in the following order:

Long Jump
Javelin Throw
200 Meters
Discus Throw
1500 Meters

- (b) The Decathlon, which shall be conducted in two consecutive 24-hour periods in the following order:

First Day: 100 Meters
 Long Jump
 Shot Put
 High Jump
 400 Meters

Second Day: 110 Meter Hurdles
 Discus Throw
 Pole Vault
 Javelin Throw
 1500 Meters

- (c) The Throws Pentathlon and Ultraweight Pentathlon, which shall be conducted on one day (see Rule 201).

NOTE: *For indoor combined event definition, see Rule 223.1.*

2. Competition for women:

- (a) The Outdoor Pentathlon, which shall be conducted on one day in the following order:

100 Meter Hurdles
High Jump
Shot Put
Long Jump
800 Meters

- (b) The Heptathlon, which shall be conducted in two consecutive 24-hour periods, in the following order:

First Day: 100 Meter Hurdles
 High Jump
 Shot Put
 200 Meters
Second Day: Long Jump
 Javelin Throw
 800 Meters

- (c) The Decathlon, which shall be conducted in two consecutive 24-hour periods according to the order in Rule 200.1(b) or in the following order:

First Day: 100 Meters
 Discus Throw
 Pole Vault
 Javelin Throw
 400 Meters

Second Day 100m Hurdles
 Long Jump
 Shot Put
 High Jump
 1500 Meters

NOTE: *The order for Masters competition and records shall only be that in Rule 200.1(b).*

- (d) The Throws Pentathlon and Ultraweight Pentathlon, which shall be conducted on one day (see Rule 201).

NOTE: *For indoor combined event definition, see Rule 223.2.*

3. The Rules of Competition of USATF for each event shall apply, with the following exceptions:

(a) In the Long Jump, Shot Put, Discus Throw, and Javelin Throw, each competitor shall be allowed three trials only.

(b) If hand timing is used, each competitor's time shall be timed by three Timers independently, using Rule 165.6 to determine the official time.

(c) False starts are called on individuals, not on the field. For a first false start by a competitor, a yellow and black (diagonally halved) card shall be raised in front of the respective competitor(s), and when lane markers are being used, a corresponding indication should be placed on the respective lane marker(s). For a second false start, the respective competitor(s) shall be disqualified.

NOTE: *In practice, when one or more athletes commit a false start, others are inclined to follow and, strictly speaking, any athlete who does so has also committed a false start. The Starter should warn or disqualify only such athlete or athletes who, in the Starter's opinion, was/were responsible for the false start. This may result in more than one athlete being warned or disqualified. If the recalled or aborted start is not due to any athlete (e.g. a false start caused by external noise), no warnings shall be given and a green card shall be shown to all the athletes. See Rule 162.17 Note.*

4. (a) The events, except as otherwise provided in these rules, shall be contested at such intervals as determined by the Track and Field Committee. Whenever possible, there shall be an interval of at least 30 minutes between the time one event ends and the next event begins for any individual athlete. If possible, the time between the last event on the first day and the first event on the second day should be at least 10 hours.

(b) In field events of a Combined Event competition for women, when more than one flight is required, a minimum of 30 minutes shall be allowed between the last attempt of the previous flight and the beginning of competition in the next flight. In the hurdles of such competition for women, where feasible, a minimum of 10 minutes shall be allowed between flights. Competition in a subsequent

flight may begin prior to 30 minutes (10 minutes in the hurdles) after the previous flight with the approval of all competitors.

NOTE: *This rule is to ensure rather than limit adequate warm-up time.*

- (c) When more than one flight is required in events, the composition of flights and, where feasible, the approximate scheduled time of each flight shall be posted prior to the competition, except that the composition of flights for the last event shall be determined just prior to the start of that event. Where field event flights are conducted sequentially, a minimum of 30 minutes between field event flights shall be allowed between the last attempt or finisher of one and the beginning of competition in the next unless approval for an earlier start is obtained by all competitors in the flight.
5. (a) If the number of competitors warrants it, they may be divided into permanent groups of not fewer than six as determined by the Games Committee or Combined Events Referee. These groupings shall continue throughout the first seven events of the decathlon and all but the last event of the other combined events.
- (b) When permanent groups are not used and individual event performance data during a predetermined period are available for most of the combined event competitors, the Games Committee, or Combined Events Referee, shall make heat and flight assignments using these data. When no performance data are available, the competitors for each heat and flight shall be drawn by lot. When this cannot be achieved due to the time schedule of events, the heats or flights for the next event should be arranged as and when competitors become available from the previous event.
- (c) In the last event of a Combined Event competition, sections, if used, should be arranged so that the last section contains the leading athletes after the penultimate event. Starting positions / lanes for this last event may be determined as deemed desirable. The Games Committee or Combined Events Referee shall arrange such section or starting positions.
- (d) In the 200m, 400m and straight running events, after ranking the athletes according to their entry performances, the lanes shall be drawn in accordance with the applicable provisions of Rule 166.2(f). If entry performances are not available, lanes shall be drawn by lot.
- (e) The order of competition within a field event, and the assignment of lanes in a track event, shall be drawn by lot for each event independently. Preferably five or more, and never less than three competitors shall be placed in a heat or flight. If there are 16 or more competitors, it is recommended that more than one facility be used for field events.

NOTE: *For Youth Athletics exception see Rule 302.6*

6. The incremental increase in the High Jump and Pole Vault in Open Men's and Women's Track and Field Championships shall be uniform throughout the competition at 3cm and 10cm, respectively.

NOTE: *For Youth Athletics exception see Rule 302.6*

7. An athlete disqualified for fouling a competitor in any event shall be permitted to compete in the remaining events, unless the Referee shall rule that mere loss of points is not sufficient penalty.
8. A competitor failing to attempt to start or take a trial in any event of the competition shall not be allowed to participate in any following events. Such competitor shall not be included in the final placing or scoring, but shall have his/her performances before withdrawing recorded in the results of the competition. Any competitor deciding to withdraw from the competition shall immediately inform the Referee of his/her decision to do so.
9. The scores of each competitor, separately and combined, should be announced to the competitors after the completion of each event.
10. Except as otherwise provided in these rules, scoring shall be based on the current World Athletics Scoring Tables for Combined Events.
NOTE 1: *World Athletics Scoring Tables for Combined Events can be found at: <https://worldathletics.org/about-iaaf/documents/technical-information>*
NOTE 2: *For Masters scoring, see Rule 332.4(a).*
11. Scoring based on only one system of timing shall be used throughout each separate event. However, for record purposes, Photo Finish times shall be applied where they are available, regardless of whether such times are available for other competitors in the event. Where Photo Finish is used, the times shall be given to 1/100th of a second and the 1/100th second scoring table shall be used.
12. The winner shall be the competitor who has scored the highest total number of points. If two or more athletes achieve an equal number of points for any place in the competition, it shall be a tie.
NOTE: *For Masters exception see Rule 332.4(b).*
13. For record purposes, if the automatic timing device should fail in a heat not involving the competitor who set the record, then the record may be scored using the automatic timing tables, although the competition would be scored and decided using the manual timing tables.
14. Appropriate implement weights, hurdle heights and hurdle spacing must be used for the age classifications entered in the competition. For Youth, see Rules 301, 302.4 and 302.6. For U20, see Rule 10.2(a). For Masters, see Rules 332.2(i) and 332.
15. Changes in the number of days defined for a Combined Events competition are not allowed except in extreme and/or unusual circumstances, including weather, as determined by the Referee. If the competition is held for a longer period than defined in Rules 200.1 and 200.2, then a Combined Event points record cannot be claimed.

RULE 201

THROWS PENTATHLON

1. The competition consists of the following five (5) events: Hammer Throw, Shot Put, Discus Throw, Javelin Throw, and Weight Throw. The events shall be contested in the above-mentioned order, and at such intervals as shall be determined by the Games Committee.

2. Three trials shall be allowed in each event.
3. The winner shall be the one who has scored the highest total of points (counting the best performance in each event) for all five (5) events, scored on the basis of the Official World Athletics Scoring Tables for the Hammer, Shot Put, Discus, and Javelin Throws, and on the basis of similarly prepared scoring tables for the Weight Throw.

NOTE: *For Masters exception see Rule 332.4(b).*

RULE 202 THROW-A-THON

1. The competition consists of the following five (5) events: Hammer Throw, Shot Put, Discus Throw, Javelin Throw and Weight Throw. The events shall be contested in the above-mentioned order and at such intervals as shall be determined by the Games Committee.
2. Three trials shall be allowed in each of three weights for each event. The three weights, and the order of their throw, shall be the standard weight, the next higher weight and the next lower weight for the age and gender of the competitor. If the higher or lower weight is not available, the standard weight for the age and gender shall be thrown.
3. The winner shall be the competitor who has scored the highest total points after combining the best performance for each of the three (3) weights in each event for all five (5) events, scored on the basis of the Official World Athletics Scoring Tables or similarly prepared tables for the individual events.

RULE 203 ULTRAWEIGHT PENTATHLON

1. The competition consists of throwing the five weights listed for each gender and age group in the table at the end of this Rule. The competition may be conducted either as an outdoor event or an indoor event.
2. Three trials shall be allowed with each weight.
3. The implements are thrown in order from lightest to heaviest.
4. The events shall be contested at such intervals as determined by the Games Committee.
5. In making a throw, the competitor may choose to assume any starting position and shall use both hands, holding the Ultraweight exclusively by the handle. Rule 187, Paragraphs 1-16 and Rule 191 shall apply. All references to the ‘circle’ shall be interpreted to mean the ‘square’ for purposes of the Ultraweight Throw. The gloves defined in Rule 187.3(c) may have closed fingers.
6. The measurement of only the 98 lb, 200 lb and 300 lb Ultraweight Throw implements shall be made from the nearest mark made by the landing of the implement to the inside of the front of the throwing square along a line from the mark. The measurement of the throw shall be made at right angles from the inside of the front foul line. The nearest visible part of the break/imprint to the throwing square shall be measured after

the implement has ceased to move. The handle imprint is not measured. The measurement for the other implements (56 lb and below) shall be as normally defined.

7. Individual points from each event are awarded based on the Ultraweight Pentathlon Scoring Table. The winner shall be the competitor who has scored the highest overall score after totaling the scores from each of the five events.

NOTE: For Masters exception see Rule 332.4(b).

8. For specifications for the implements, see Rules 195.8 and 195.9.

			Men					
Age Group	Weight #	Super Weight #	35 lb	20kg	56 lb	98 lb	200 lb	300 lb
Open-49	35	56				x	x	x
50-59	25	56				x	x	x
60-69	20	20 kg			x	x	x	
70-79	16	35		x	x	x		
80+	12	25	x	x	x			

			Women					
Age Group	Weight #	Super Weight #	20 lb	25 lb	35 lb	20kg	56 lb	98 lb
Open-49	20	35				x	x	x
50-59	16	25			x	x	x	
60-74	12	20		x	x	x		
75+	4kg	16	x	x	x			

SECTION V
INDOOR AND SHORT TRACK COMPETITIONS

RULE 210
APPLICABILITY OF INDOOR RULES

With the exceptions stated in this Section and the requirement for wind measurement as set out in Rule 163.10, the Rules of Competition in Sections I to IV shall apply to indoor competitions.

RULE 211
THE INDOOR STADIUM / SHORT TRACK

1. The stadium may be completely enclosed and covered. If enclosed and covered, lighting, heating and ventilation shall be provided to give satisfactory conditions for competition and to be designated as Indoor.
2. The arena should include an oval track; a straight track for sprints and hurdles; runways and landing areas for jumping events. In addition, a circle and landing sector for the Shot Put and Weight Throw should be provided, whether permanent or temporary. It is preferred that all facilities conform to the specifications in the World Athletics Track and Field Facilities Manual.
3. All tracks, runways and take-off surface areas shall be covered with a synthetic material or have a wooden surface. The synthetic material should preferably be able to accept 6mm spikes in running shoes. If the facility operator mandates an alternate maximum or prohibits the use of certain shaped spikes, this shall apply and the competitors notified accordingly. See Rule 143.3.
4. The foundation on which the surface of the track, runways and take-off area is laid shall either be solid or, if of suspended construction (such as wooden boards or plywood sheets mounted on joists), without any special sprung sections and, as far as technically possible, each runway and take-off area shall have a uniform resilience throughout. This shall be checked before each competition. A 'sprung section' is any deliberately engineered or constructed section designed to give extra assistance to a competitor.

NOTE: *Full technical information on track construction, layout and markings is contained in the World Athletics' Manual on Track and Field Facilities, which is available from World Athletics at www.worldathletics.org.*

RULE 212
TRACK LANES AND MEASUREMENT

1. The lateral inclination of the straight track shall not exceed 1:100 and the inclination in the running direction shall not exceed 1:250 at any point and 1:1000 overall.
2. The nominal length of the oval should be preferably 200m. It shall consist of two parallel straights and two turns which may be banked and whose radii should be equal. The inside edge of the line or curb shall be horizontal throughout the length of the track. However, this curb or line may be located on the banking slope such that the pivot line of the banking shall be horizontal throughout the length of the banking.

NOTE: Performances achieved on an oval track with a nominal length other than 200m may count towards the Short Track results if the nominal length does not exceed 201.20m (220 yards).

LANES

3. The straight track should have a minimum of 6 and a maximum of 8 lanes separated and bounded on both sides by white lines 5cm wide. The lanes shall all be 1.22m \pm 0.01 m wide including the lane line on the right. On tracks whose width does not permit 6 lanes of that width, the minimum width of the lanes may be 1.07m \pm 0.01m.
4. The oval should have a minimum of 4 and a maximum of 6 lanes. The nominal width of the lanes shall be between 0.90m and 1.22m including the lane line to the right. All lanes shall be of the same width with a tolerance of \pm 0.01m to the selected nominal width. The lanes shall be separated by white lines 5cm wide.

NOTE: For top level competitions, it will be useful to have a 6-lane track. The ideal width of the lanes of an oval track should be 1m.

THE START AND FINISH

5. There should be a clearance on the straight track of at least 3m behind the start line and at least 10m beyond the finish line free of any obstruction with adequate provision beyond the finish for an athlete to come to a halt without injury.

NOTE: It is strongly recommended that the minimum clearance beyond the finish line should be 15m.

6. The start and finish of a race shall be denoted by white lines 5cm wide, at right angles to the lane lines for straight parts of the track and along a radius line for curved parts of the track.
7. The requirements for the finish line are: if at all possible there should be only one for all the different lengths of oval races; it shall be on a straight part of the oval; and as much of that straight as possible should be before the finish.
8. As far as possible, start lines (and take-over lines for relay races) should not be on the steepest part of the banking.

BANKING

9. The angle of banking in all lanes in the curve and separately in the straight should be the same at any cross section of the oval. The straight may be flat or have a maximum lateral inclination of 1:100 toward the inside lane. In order to ease the change from the straight to the banked turn, the change may be made with a smooth gradual horizontal transition which may be extended up to 5m into the straight. In addition, there should be a vertical transition.

OVAL EDGE MARKINGS

10. Although a raised border for at least the curved portion of the oval is preferred, an indoor track may be bordered with a white line 5cm wide and marked additionally with cones or flags. The cones shall be at least 20cm high. The flags shall be approximately 25cm x 20cm in size, at least 45cm high and set at an angle of 120 degrees to the track surface. The cones or flags shall be placed on the white line so that the outward edge of the base of the cone or flag pole coincides with the outward edge of the white line closest to the track. The cones or flags shall be placed at distances not exceeding 1.5m on the turns and 10m on the straights.

NOTE: For all indoor Championships, the use of an inside curb for at least the curved portion of the oval is strongly recommended.

BREAK LINE

11. The break line shall be an arced line marked after each turn, 5cm wide, across all lanes other than lane one. See Rule 160.8(c) and Rule 160.9 for description and additional markings.

**RULE 214
REGULATIONS FOR FORMING HEATS**

1. The heats or sections for all rounds in the running events, to the extent feasible, shall be formed according to the following tables. For Championship and selection meets, alternate formation or advancement procedures may be used as included in the entry material/Technical Information.
 - (a) Qualification from Preliminary Heats: In indoor competitions, with an eight lane straight and a six lane oval, the following tables shall, in the absence of extraordinary circumstances, be used to determine the number of rounds and the number of heats in each round to be held and the qualification procedure for each round of track events:

60m, 60mH							
Entries	Trial Heats	Qualifying on Place	Qualifying on Time	Semi Heats	Qualifying on Place	Qualifying on Time	Final
9-16	0	-	-	2	3	2	8
17-24	0	-	-	3	2	2	8
25-32	4	3	4	2	3	2	8
33-40	5	4	4	3	2	2	8
41-48	6	3	6	3	2	2	8
49-56	7	3	3	3	2	2	8

200m, 400m, 4 x 200m, 4 x 400m							
Entries	Trial Heats	Qualifying on Place	Qualifying on Time	Semi Heats	Qualifying on Place	Qualifying on Time	Final
6-10	-	-	-	2	2	2	6
11-15	-	-	-	3	1	3	6
16-20	-	-	-	4	1	2	6
21-25	5	2	2	2	2	2	6
26-30	6	2	6	3	1	3	6
31-35	7	2	4	3	1	3	6
36-40	8	2	2	3	1	3	6

800m							
Entries	Trial Heats	Qualifying on Place	Qualifying on Time	Semi Heats	Qualifying on Place	Qualifying on Time	Final
7-12	-	-	-	2	2	2	6
13-18	3	3	3	2	2	2	6
19-24	4	2	4	2	2	2	6
25-30	5	2	2	2	2	2	6
31-36	6	2	6	3	1	3	6

1500m							
Entries	Trial Heats	Qualifying on Place	Qualifying on Time	Semi Heats	Qualifying on Place	Qualifying on Time	Final
12-18	-	-	-	2	3	3	9
19-27	-	-	-	3	2	3	9
28-36	-	-	-	4	2	1	9
37-45	5	3	3	2	3	3	9

3000m				
Entries	Trial Heats	Qualifying on Place	Qualifying on Time	Final
16-24	2	4	4	12
25-36	3	3	3	12
37-48	4	2	4	12

(b) Principles of assigning lanes

- i. Within each race, for all rounds of all events, run wholly or partly in lanes around a turn, where there are successive rounds of an event:
 - a. In the first round in the 200 meters and 400 meters, lane one shall not be utilized;
 - b. A draw for lanes will be made for the outer two lanes between the two highest ranked athletes;
 - c. A draw for lanes will be made for the next two lanes between the third and fourth ranked athletes;
 - d. A draw for lanes will be made for any remaining inner lanes between the remaining athletes.
- ii. The rankings referred to shall be those identified in Rule 166.2(d).
- iii. For all other races the lane order shall be drawn in accordance with Rule 166.2(f).

2. Conduct of Races

- (a) Races of up to and including 300m shall be run entirely in lanes.
- (b) Races over 300m and less than 800m shall start and continue in lanes until the end of the second turn.
- (c) In races of 800m each athlete may be assigned a separate lane, or no more than two per lane, or a group start with or without a second arc may be used, preferably using lanes 1 and 4. In these cases, athletes may leave their lane, or those running in the outer group may join the inner group, only after the break line marked at the end of the second turn. A single curved start-line may be used.
- (d) Races longer than 800m shall be run without lanes using an arced start line or a group start. If a group start is used, the break line shall be at the end of either the first or second turn to coincide with the starting stagger.

- (c) In the 400 Meters, at least one half-hour rest shall be allowed between heats, semi-final, and final respectively. In races of 800m or longer, at least 45 minutes rest shall be allowed between heats and final.

NOTE 1: *Group starts shall utilize Rule 162.17.*

NOTE 2: *For Youth Athletics exception see Rule 303.*

3. **International Team Qualification** - When the Open National Championship is used to select a team to represent the USA in international competition, the Chairs of the Men's and Women's Sport Committees may establish rounds and advancement procedures in oval events of less than 1500m that result in a two-section timed final.

RULE 216 SHOES

When a competition is conducted on a synthetic surface, that part of each spike which projects from the sole or the heel shall not exceed 6mm, or as required by the Games Committee, in addition to the provisions of Rule 143.3.

RULE 217 HURDLES

The standard distances and specifications for hurdle races shall be as set out in the following table, with the height of the men's hurdles at 1.067m (42in.) and the women's at 0.840m (33in.). For experimental purposes, women's events may be conducted with a hurdle height of 0.914m (36in.).

NOTE: *For specifications for Masters races see Rule 332.2(i).*

	Distance of Race	Number of Hurdles	Distance from Start to First Hurdle	Distance Between Hurdles	Distance from Last Hurdle to Finish
Men	50m	4	13.72m	9.14m	8.86m
Men	55m	5	13.72m	9.14m	4.72m
Men	60m	5	13.72m	9.14m	9.72m
Women	50m	4	13m	8.5m	11.5m
Women	55m	5	13m	8.5m	8m
Women	60m	5	13m	8.5m	13m

RULE 218 RELAY RACES

1. The 4x200 Meter Relay shall be run in lanes for the first leg, as well as that part of the second leg up to the nearer edge of the break line used for the individual 800m at the end of the first turn, as described in Rule 160.8(c), where runners may leave their respective lanes. Rule 170.13 shall apply. Each exchange zone shall be 20m long and each outgoing runner shall start within the zone.
2. The 4x400 Meter Relay, **4x400m Mixed Relay** and the indoor Sprint Medley Relay shall be run according to Rule 214.2(c).
3. The 4x800 Meter Relay shall be run according to Rule 214.2(d).

4. The Distance Medley Relay shall be run without the use of lanes.
5. The runners in the third and fourth legs of the 4x200 Meters Relay and in each leg other than the first of the indoor Sprint Medley Relay and Distance Medley Relay shall, under the direction of a designated official, place themselves in their waiting position in the same order (inside to out) as the order of their respective team members as they enter the last turn before the exchange. Once the incoming runners have passed this point, the waiting runners shall maintain their order, and shall not exchange positions at the beginning of the exchange zone. Should any runner not comply with this paragraph, his/her team shall be disqualified.

The above provision shall apply to each leg other than the first of the indoor 4x400m, 4x400m Mixed and 4x800m races except that the waiting position is as their respective team member passes the finish line to enter the last lap of their leg.

NOTE: *Due to the narrow lanes, indoor relay races have a greater liability for collisions and unintended obstruction than outdoor relay races. It is therefore recommended that when possible an empty lane be left between each team.*

RULE 219 HIGH JUMP

1. If portable mats are used, all references in the Rules to the level of the take-off area must be construed as referring to the level of the top surface of the mat.
2. An athlete may start an approach on the banking of the oval track provided that the last 15 meters of the run up is on a runway complying with Rule 180.21 and Rule 180.23.

RULE 220 POLE VAULT

An athlete may start an approach on the banking of the oval track provided that the last 40 meters of the run up is on a runway complying with Rule 180.21 and Rule 180.23.

RULE 221 HORIZONTAL JUMPS

An athlete may start an approach on the banking of the oval track provided that the last 40 meters of the run up is on a runway complying with Rule 180.21 and Rule 180.23.

RULE 222 SHOT PUT/ WEIGHT THROW

LANDING SECTOR

1. The landing sector shall consist of some suitable material on which the shot will make an imprint but which will minimize any bounce.
2. The landing sector shall be surrounded at the far end and on the two sides, as close to the circle as may be necessary for safety of the other athletes and officials, by a stop-barrier which should stop a shot whether in flight or bouncing from the landing surface.

3. In view of the limited space inside an indoor or Short Track arena, the area enclosed by the stop-barrier may not be large enough to include a full 34.92 degree sector. The following conditions shall apply to any such restriction.
 - (a) The stop-barrier at the far end shall be at least 50cm beyond the current world Shot Put record for men or women.
 - (b) The sector lines on either side shall be symmetrical about the center line of the 34.92 degree sector.
 - (c) The sector lines run radial from the center of the Shot Put circle at an angle of 34.92 degrees until the sector has a width of at least 9 meters. From there outward, the sector lines may run parallel to the center line of the landing sector.

NOTE: *The movement of the panels in Note 1 to Rule 190 should be modified to reflect the specifications of the landing sector.*
4. The circle may be marked on the floor.

CONSTRUCTION AND SPECIFICATIONS OF THE SHOT

5. For indoor competition, a shot which is solid metal cased or a latex covered metal shell or one made of soft plastic or rubber incasing a suitable material may be allowed. The shot used shall conform to the construction and weight specifications in Rule 188.3 and Rule 188.4. The indoor shot must not allow that indentations in the surface be created to improve a grip. The diameter for a synthetic covered indoor shot can be a maximum of 15mm larger than the corresponding outdoor men's shot and 20mm larger than the corresponding outdoor women's shot. Only one type of shot may be used in a competition.

NOTE 1: *For Masters Men indoor competition the maximum diameter of all shots is 145mm.*

NOTE 2: *For Youth Boys indoor competition, the diameter for the 4kg shot may be a maximum of 20mm larger than the 4kg outdoor shot.*

RULE 223 COMBINED EVENTS

1. **Competition for Men**
 - (a) **Pentathlon:** The Pentathlon consists of five events, which shall be held on one day in the following order:
60m Hurdles, Long Jump, Shot Put, High Jump, 1000m.
 - (b) **Heptathlon:** The Heptathlon consists of seven events which shall be held in two consecutive 24-hour periods in the following order:
First day: 60m, Long Jump, Shot Put, High Jump.
Second day: 60m Hurdles, Pole Vault, 1000m.
2. **Competition for Women**

Pentathlon: The Pentathlon consists of five events and shall be held on one day in the following order:
60m Hurdles, High Jump, Shot Put, Long Jump, 800m.

HEATS AND GROUPS

3. Preferably four or more, and never fewer than three, athletes shall be placed in each heat or group.

**SECTION VI
RACE WALKING**

**RULE 230
JUDGES OF RACE WALKING**

1. Judging

- (a) The Judges of Race Walking shall have the sole authority to determine the fairness or unfairness of walking, and their Red Card rulings thereon shall be final and without appeal. Judging decisions are made as seen by the human eye.
- (b) The appointed Judges of Race Walking shall elect a Chief Judge, if one has not been appointed previously by the Race Walking Officials Selection Committee.
- (c) The Chief Judge shall assign the Judges to their respective judging areas and explain the judging procedure to be used during the race. The Chief Judge shall act as the supervising official for the competition and shall judge the full competition. In addition, at International Selection Competitions, National Championships and other events as determined by the appropriate Sport Committee, the Chief Judge shall act as a Judge as described in 230.3(f).
- (d) At International Selection Competitions one or more Chief Judge's Assistants should be appointed. The Chief Judge's Assistants shall not act as a Race Walking Judge.
- (e) All Judges shall be currently certified as Race Walk Judges by USATF or by another World Athletics member federation.
- (f) All Judges shall act in an individual capacity.
- (g) The Chief Judge will serve as the Referee and Chief Umpire if none is assigned. The Judges will serve as Umpires if an insufficient number are assigned.
- (h) In road races, depending on the size and layout of the course there should be a minimum of six to a maximum of nine Judges including the Chief Judge. In track races, indoors and outdoors, there should be five Judges including the Chief Judge. At International Selection Competitions there shall be five judges (including the Chief Judge) when the trial is conducted on a track, and there shall be no more than 9 judges (including the Chief Judge) when the trial is conducted on a road course.
- (i) All Judges' Tally Sheets shall be turned in to the Recorder at the end of the race. A copy of the completed Judges' Summary Sheet, identifying competitors, offenses, disqualifications and time of notifications, shall be certified by the Chief Judge/Referee and posted as soon after the event as possible. The original of this sheet shall be delivered to the Competition Secretary and made part of the official event records.

2. Yellow Paddle

- (a) When a judge is not completely satisfied that the athlete is fully complying with Rule 232.2 the judge should, where possible, show the athlete a yellow paddle indicating the offence. An athlete cannot be given a second yellow paddle by the

same judge for the same offense. Having shown a yellow paddle to an athlete, the Judge shall inform the Chief Judge of this action after the competition.

- (b) Each Judge shall use two yellow paddles for signaling cautions. One paddle should have the symbol ~ indicating "Loss of Contact" on both sides and the other paddle should have the symbol > indicating "Bent Knee" on both sides to show the reason for the caution.

3. **Disqualification**

- (a) When a Judge observes a competitor who fails to comply with Rule 232.2, the Judge shall issue a Red Card. A Red Card is that Judge's proposal for disqualification of a competitor.
- (b) Red Cards shall be given to the Recorder as soon as possible. If there is no Recorder, the Red Card shall be given to the Chief Judge. A Judge shall record all proposals for disqualification on the Judge's Tally Sheet.
- (c) Except as provided in Rule 230.3(j), when Red Cards from three different Judges have been sent to the Recorder or Chief Judge on the same competitor, that competitor is disqualified and shall be notified of this disqualification by the Chief Judge or the Chief Judge's Assistant by being shown a red paddle. Any disqualified athlete who fails to leave the course or track or comply with directions given under Rule 230.3(j) to enter and remain for the required period in the Penalty Zone may be liable to further disciplinary action in accordance with Rule 145.2.
- (d) Notification of disqualification shall be given as soon as practicable after the competitor has finished, if it is impractical to notify the competitor of the disqualification during the race. The failure to give prompt notification shall not result in the reinstatement of a disqualified competitor.
- (e) The Chief Judge and, when applicable, the Chief Judge's Assistant, shall use a red paddle for signaling disqualification.
- (f) At International Selection Competitions, National Championships and other events as determined by the appropriate Sport Committee, the Chief Judge has the power to disqualify a competitor in the last 100m when his/her mode of progression obviously fails to comply with Rule 232.2 regardless of the number of previous Red Cards the Chief Judge has received for that competitor. A competitor who is disqualified under these circumstances shall be allowed to finish the race. The competitor shall be notified of this disqualification by the Chief Judge or a Chief Judge's Assistant by showing the athlete a red paddle at the earliest opportunity after the athlete has finished the race. Disqualification by the Chief Judge, in the last 100m, shall include a Red Card if one has not been previously issued by the Chief Judge for that competitor.
- (g) For Championships and International Selection Competitions, one or more posting boards shall be placed on the course and/or near the finish to keep competitors informed about the number of Red Cards that have been received by the Recorder or Chief Judge for each competitor. The symbol for each offense shall also be indicated on the posting board.

- (h) Where appropriate equipment is available, computer devices with transmission capability may be used by the judges in communicating proposals for disqualification to the Recorder and the posting board(s).
- (i) If the Referee is satisfied, on the report of a Judge or Umpire or otherwise, that a competitor has left the marked course thereby shortening the distance to be covered, the competitor shall be disqualified.
- (j) A Penalty Zone may be used as determined by the Sport Committee. In such cases a competitor will be required to enter the Penalty Zone and remain there for the applicable period once they have received three Red Cards and are so advised by the Chief Judge or someone delegated by him.

The applicable period in the Penalty Zone shall be:

For races up to and including 5km - 0.5 min; 10km - 1 min; Half-Marathon - 2 min; 30km - 3 min; 35km - 3.5 min; Marathon - 4 min; 50km - 5 min.

If, at any time, the competitor receives an additional Red Card from a judge other than one of the three who had previously sent a Red Card, he/she shall be disqualified. A competitor who fails to enter the Penalty Zone when required to do so, or remain there for the applicable period, and who continues the race, shall be disqualified by the Referee. If a competitor receives a third Red Card and it is no longer practicable to direct him/her to enter the Penalty Zone before the end of the race, the Referee shall add the time the competitor would have been required to spend in the Penalty Zone to the competitor's finishing time and adjust the finishing order as may be necessary.

RULE 231 RACE WALKING OFFICIALS

Race Walking Officials may be appointed to assist in the administration of the Race Walking event(s) by administering the posting board, recording information for the Chief Judge, assisting the Chief Judge and/or other Judges, overseeing and coordinating the functions of the Lap Counters, and performing such other relevant duties as may be required by the Chief Judge or the Meet or Event Director.

RULE 232 GENERAL RULES

1. Article III and Sections I and VII of Article IV shall be followed unless otherwise provided in this Section VI. In the rules of those articles and sections, all forms of the word "run" shall be construed to apply to the corresponding form of "walk."
2. Definition of Race Walking. Race Walking is a progression of steps so taken that the walker makes contact with the ground so that no visible (to the human eye) loss of contact occurs. The advancing leg must be straightened (i.e., not bent at the knee) from the moment of first contact with the ground until the leg is in the vertical upright position.

Disqualification for failure to adhere to the above definition is governed by Rule 230.3.

3. Race Conduct. For all Race Walking events, the following code of conduct must be adhered to:
 - (a) In track races a competitor who is disqualified must immediately leave the track. In road races the disqualified competitor must, immediately after being disqualified, remove the distinguishing numbers that he or she is wearing and leave the course. A competitor who fails to leave the track or course, as required by this Rule, shall be subject to Rule 145. No finishing time shall be listed in results for any competitor who receives notice of disqualification after the competitor has completed the race.
 - (b) In walks where multiple distances are contested simultaneously, each competitor must declare on the entry form which distance is being entered. Times for other distances (but not placings) are valid only if the competitor finishes the distance entered.
 - (c) A race must have a minimum of three Judges as prescribed in Rule 230.1(c). For record requirements, see Rule 266.
4.
 - (a) Water and/or refreshment stations shall be provided at the beginning and end of the race.
 - (b) For all events up to and including 10km, water only drinking/sponging stations shall be provided at suitable intervals if weather conditions warrant such provision. Mist stations may also be provided, when considered appropriate by the Organizing Committee.
 - (c) For all events longer than 10km, refreshment stations shall be provided every lap. In addition, water only drinking/sponging stations shall be placed approximately midway between the refreshment stations or more frequently if weather conditions warrant such provision.
 - (d) Competitors shall be permitted to provide their own refreshments at refreshment stations. A competitor who receives or collects refreshment from a place other than official stations, except where provided for medical reasons from or under the direction of race officials, or takes the refreshment of another competitor, should, for a first such offense, be warned by the Referee normally by showing a yellow card. For a second offense, the Referee shall disqualify the competitor, normally by showing a red card. The competitor shall then immediately leave the course.

NOTE: *A competitor may receive from or pass to another competitor refreshment, water or sponges provided it was carried from the start or collected or received at an official station. However, any continuous support from a competitor to one or more others in such a way may be regarded as unfair assistance and warnings and/or disqualifications as outlined above may be applied.*
5. Courses and Conditions for Walking Events.
 - (a) In Road Championships, the circuit for events of 10km and longer shall be a maximum of 2000m. The circuit for events of less than 10km should be a maximum of 1250m. No circuit should be shorter than 1000m.
 - (b) Race Walking events shall be so arranged as to ensure that the entire event is held in daylight or with suitable artificial light.

6. National Championships and all other Race Walking events that qualify or advance a competitor to subsequent events must be competitive Race Walk only events that comply fully with Race Walk Competition Rules.
7. National Championships and International Selection Competitions shall be American Record eligible events, conforming with Rule 266.

**SECTION VII
LONG DISTANCE AND ROAD EVENTS
(Running and Walking)**

**RULE 240
COURSE CERTIFICATION**

1. The course used for a competition shall be certified prior to the running of the event unless the course is deemed uncertifiable by the Road Running Technical Council.
2. Definition of course:
 - (a) Path: A running course shall be defined as the streets, roads, paths, marked paths on grass, gravel or dirt, and/or paths using established permanent landmarks or benchmarks which is intended as the runner's path for any type of race; and
 - (b) Shortest possible route: The measured running course shall involve the course noted above and the measurement shall follow the runner's shortest possible legal route.
3. **USATF Certification** - A course may be designated as "USA Track & Field Certified" only if a final signatory national certifier who is approved by the certification chair of the Road Running Technical Council of USATF has determined that the shortest possible route has been measured with reasonable accuracy:
 - (a) Stated distance: Courses meet certification standards if the measurements demonstrate that the course is at least the stated distance. In order to ensure that a course is not short, the measurement must include an addition of 1/1000th of the stated race distance;
NOTE: *Information concerning acceptable methods of measuring courses should be obtained from the Road Running Technical Council of USATF prior to the measurement of a long distance course.*
 - (b) Effective date: Certification is effective as of the date that all measurements and necessary adjustments are submitted as evidenced by the postmark, although the actual review and approval of the certification may be at a later date.

**RULE 241
MEDICAL AND REFRESHMENT SERVICES FOR ROAD EVENTS**

1. The organizers of road races should provide appropriate medical and refreshment services for all competitors.
 - (a) **Medical examinations** - A hands-on medical examination during the progress of an event by designated medical personnel clearly identified by the organizers shall not be considered assistance.
 - (b) Adequate first aid facilities should be available.
 - (c) A competitor must retire from a race immediately if directed to do so by a duly authorized member of the race medical staff. See Rule 144.4(c).
2. Drinking / Sponging and Refreshment Stations
 - (a) Water and other suitable refreshments shall be available at the start and finish of all races.

- (b) For all events, water shall be available at suitable intervals of approximately 5km. For events longer than 10km, refreshments other than water may be made available at these points.

NOTE 1: *Where conditions warrant, taking into account the nature of the event, the weather conditions and the state of fitness of the majority of the competitors, water and/or refreshments may be placed at more regular intervals along the route.*

NOTE 2: *Mist stations may also be arranged, when considered appropriate under certain organizational and/or climatic conditions.*

- (c) Refreshments may include drinks, energy supplements and/or foodstuffs. The Organizing Committee will determine which refreshments it will provide based on prevailing conditions.
- (d) The Organizing Committee may permit athletes to provide their own refreshments, in which case the athlete shall nominate at which stations they shall be made available to the athlete. Refreshments provided by the athletes shall be kept under the supervision of officials designated by the Organizing Committee from the time that the refreshments are lodged by the athletes or their representatives. Those officials shall ensure that the refreshments are not altered or tampered with in any way. In National Championships of 20k and longer, the Organizing Committee shall make provisions for the collection and distribution of personal refreshments for those competing for the championship, as determined by the Games Committee.
- (e) The Organizing Committee shall delineate, by barriers, tables or markings on the ground, the area from which refreshments can be collected or received. It should not be directly in the line of the measured route. Refreshments shall be placed so that they are easily accessible to, or may be put by authorized persons into the hands of, the athletes. Such persons shall remain inside the designated area and not enter the course nor obstruct any athlete. No official shall, under any circumstances, move beside an athlete while he is taking refreshment or water.
- (f) A competitor who collects refreshment from a place other than a refreshment station is liable to disqualification by the Referee.
NOTE: *A competitor may receive from or pass to another competitor refreshment, water or sponges provided it was carried from the start or collected or received at an official station. However, any continuous support from a competitor to one or more others in such a way may be regarded as unfair assistance and warnings and/or disqualifications as outlined above may be applied.*
- (g) For Mountain, Ultra-Marathon, and Trail Races, athletes may receive physiotherapy (massage, etc.) at official stations. This may be done by personal representatives of the athletes or persons designated by the Organizing Committee. See Rule 250 through Rule 252 for Cross Country, Mountain and Trail Running.

RULE 242

STARTING A RUNNING EVENT

1. All competitors are responsible for knowing the starting time of the event(s), for knowing the registration or check-in method utilized at the start (for some or all of the competitors), and for being at the start line at the appointed time for instructions and the start of the race.

2. Ten to fifteen minutes (or as otherwise specified) before the start of the race, all entries should be closed and the athletes directed to the start line for final instructions and the start of the race.
3. One or more start lines may be used in any road race. In the event that more than one start line is used, it is recommended that the point where the runners converge be at least 800m (1/2 mile) from the start line.
4. Runners should be seeded according to ability in any race when all of the runners cannot be placed on the start line.
5. The races shall be started in accordance with Rule 162.5, including the use of a gun, cannon, air horn or by initiating another distinctive and unambiguous start signal suitable for the relevant competition. The commands and procedures for races longer than 400m, Rule 162.8, shall be used. The method of starting to be used must be explained prior to the start in such a manner that all participants will receive and understand the information. The athletes shall assemble on the start line in the manner determined by the organizers. In races which include a large number of competitors, a five-minute, three-minute and one-minute warning before the start of the race should be given. False starts in road races should not be recalled. A Cross Country race may be recalled upon a false start or a fall which impacts the field within the first 100m.
6. The Starter shall report to the Referee any misconduct by any competitor(s) at the start. The Referee shall have the authority to disqualify such competitors.
7. In events using transponder reading devices located on the running surface, at least 15cm of the last device shall be of a color in contrast to the running surface and other parts of the device to indicate the start line. The last device shall be placed so that the edge of the contrasting color closest to the course is the start line. Any additional or backup device shall be placed before the start line. See Rule 165.15.

RULE 243 COURSE MARKING AND MONITORING

1. Running courses shall be adequately marked at strategic points to keep the competitors on course. The details of which should be published in the entry material/Technical Information or program as a responsibility of the organizing body.
 - (a) Each turn and intersection shall be clearly marked in such a way that there will be no doubt as to the direction the runner should go to stay on course.
 - (b) Distance markers should be located throughout the course. It is recommended that markers be placed at maximum intervals of 3 to 5km or 2 to 3 miles. The spacing of their intervals shall be determined by the Games Committee.
 - (c) The measurement line should be marked along the course in a distinctive color that cannot be mistaken for other markings.
2. Turns and major intersections on the course shall be monitored.
 - (a) Umpires should be placed at regular intervals and in each key point. Other umpires should move along the course during the race.

- (b) Monitors shall always be standing and shall be located at or before the change of direction, not after it occurs on the course.
 - (c) Scorers shall keep a record of the runners and their running times at specific points on the course.
 - (d) Whenever possible, the route of the competition should be free of vehicular traffic or nearly so. All dangerous intersections should be staffed to provide for traffic and spectator control.
 - (e) A lead vehicle should be provided with additional vehicles to assist in monitoring the competition, timing, or other required functions.
 - (f) Whenever possible, elapsed times should be displayed or read at various points along the running course for the benefit of the runners and to record such time intervals.
 - (g) In Trail or Mountain races of 100km or greater, the Games Committee may permit monitors for part or all of the race. Such monitors shall be designated and properly identified. Except for hands-on medical examination, or in designated refreshment stations, a monitor shall remain behind the competing athlete at an interval of at least 10 meters.
NOTE: *Verbal or other pacing, conveying advice, exchanging supplies or providing non-safety related assistance is subject to Rule 144, where the athlete may be disqualified, and Rule 252.5.*
3. Runner's identification shall consist of running numbers pinned securely on the front of each runner's uniform and displayed throughout the race. The registration list will contain each runner's name and running number.
 4. Any competitor who has been found by the Referee and/or Jury of Appeal to have gained an unfair advantage by intentionally shortening the route of the race ("cutting the course") shall be immediately disqualified from the competition. See also Rule 163.6.

RULE 244 **THE FINISH LINE**

1. The finish shall be of a material which will adhere to a fixed position on the running surface. The line shall be placed so that the finish of the course is the edge of the line closest to the approaching runners.
2. Should there be an extensive painted design adjacent and prior to the finish line, the exact location of the finish line shall be clearly stated in instructions to all competitors.
3. A tape may be held above and parallel to the finish line and at right angles to the course by individuals who are not serving as judges. The individuals holding the tape shall be positioned so they do not interfere with the view of the judges. This tape is not itself the finish line, but is there only to indicate the approximate location of the actual finish line to approaching runners.
4. In events using transponder reading devices located on the running surface, the device shall be of a color in contrast to the running surface and other parts of the device to

indicate the finish line. The first device shall be placed so that the edge of the contrasting color closest to the course is the finish line. Any additional or backup devices shall be placed beyond the finish line. See Rule 165.15.

5. Races may use separate points along the finish line as the crossing location of the first men's and first women's finishers.
6. Official places and times shall be determined according to Rules 163 and 165. In addition to the primary finish line system, other officially designated imaging systems may be used to review the order of finish.
7. For Open Long Distance Running Championships, Rule 16 and Rule 20, the finish line system to determine official places and times shall include:
 - (a) A Photo Finish camera to determine order of finish.
 - (b) A video recording of the front view of the finishers.
 - (c) Synchronized replay and reading of the Photo Finish and video recordings.
 - (d) A timing system in compliance with Rule 165.
 - (e) Redundant systems, including separate power/battery backups, for the above.

NOTE: *Any race with significant prize money or being used to select part or all of a team for a world championship event should use such a system.*

RULE 246 SCORING RUNNING EVENTS

1. The method of team scoring shall be set forth in the entry blank and printed program for the race.
2. Individuals will be scored according to the designated divisions.
3. See Rules 5, 7, 16.9, 20.9 for scoring of Championship races.

SECTION VIII
CROSS COUNTRY, MOUNTAIN AND TRAIL RUNNING

RULE 250
GENERAL

1. **Variability** - The varying circumstances in which cross country, trail and mountain running are practiced preclude rigid legislation standardizing this sport. The Rules in this Section are intended as a guide for cross country, mountain and trail running.
2. The rules of Long Distance Running, Rule 240 through Rule 246, shall apply where appropriate unless otherwise modified in this section.

NOTE: *The LDR Rules include Course Certification, Medical / Refreshment Services, Start Line Requirements / Procedure, Course Markings, Course Monitoring, Finish Line Requirements / Procedure, Timing / Placing / Results Recording Procedure and Team Scoring.*

3. Finishers should be recorded and timed according to Rule 244.6.

NOTE 1: *For Cross Country exception see Rule 251.12.*

NOTE 2: *For Youth Cross Country exception see Rule 304.*

RULE 251
CROSS COUNTRY

1. **Participation** - Cross country is basically a team sport, but participation is not limited to teams, and individual entries may be accepted.
2. The race distance must be declared and the course briefly described at the time invitations are extended. See Rule 15 for required distances.
3. The jersey or singlet worn by the members of a team in cross country shall be basically identical for each member in color and style, and must be clearly visible throughout the race, i.e., worn as the outer garment if other apparel items are worn underneath by one or more team members. Because of the nature of cross country running, the preferences of individual athletes in certain weather situations will allow other apparel items to vary widely without penalty. Individuals not complying may be disqualified from scoring for a team.

Course

4. The race shall be run over a course confined, to the extent possible, to open country, fields, parks, golf courses, and grasslands. The traversing of paved roads should be kept to a minimum.
5. The course shall be marked, preferably with red flags to indicate a left turn, yellow flags to indicate a right turn and blue flags to indicate continuing straight ahead. All flags must be visible from the point where the runner passes the previous flag, with a maximum interval of 50m. Each kilometer point should be clearly recognizable. The course should be laid out so that there are no sharp turns at the beginning of the course and so that it is not less than 9m (approximately 10 yds.) wide at any point. See Rule 243.
6. Courses should be designed so as to avoid very high obstacles, deep ditches, dangerous ascents or descents, thick undergrowth, and, in general, any obstacle which would constitute a difficulty beyond the aim of the competition. The starting

area should avoid any significant turns for at least the first 400m. The width of the starting area should be such as to accommodate the competitive field.

7. It is preferable that artificial obstacles not be used, but if the requirements of the event render them unavoidable, they should be made to simulate natural obstacles encountered in open country. In World Trials competition, barriers simulating those that are planned to be used in the World Championships should be constructed. In races where there are large numbers of competitors, narrow gaps, or other hindrances that would deny to the competitors an unhampered run, obstacles should be avoided for the first 800 meters.
8. **Start** - Starting boxes should be used and randomly assigned by the Games Committee or the Meet Director for each team in team races and the members of each team shall line up in an order of their own choosing within their assigned position. In non-team races, the competitors shall be lined up in the manner determined by the Games Committee. See Rule 242.

Finish

9. The finish area for a cross country race should include a final straightaway of at least 200m with clear visibility of the finish line by all runners and clear visibility of the runners by spectators. A straightaway of 400m is preferred. Alternatively, the race may finish with one half or more of a lap on a standard track.
10. The finish line shall be marked both with a solid line and an overhead banner or other indicator of the finish line. Judges, when used, shall be stationed at the finish line to determine the order of finish.
11. Where transponders are not used to determine a preliminary order of finish, a finish chute system of sufficient capacity should be constructed to enable the race officials to hold each runner until the method or methods of scoring are applied. It is recommended that at least two independent systems (e.g., pull tags and recording of competitor numbers) be used to score.
12. At the Open, U20 and Masters Cross Country Championships, three independent finish line systems shall be used, at least one of which shall produce a visual record of the finishers as approved by the Games Committee. Transponder Timing shall only be used to determine the preliminary order of finish. Review of the imaging system shall determine the official order of finish.
13. **Relays** - For Cross-Country Relays, lines 50mm wide and 20m apart shall be drawn across the course to denote the takeover zone. All takeover procedures, which, unless otherwise specified by the Games Committee, shall comprise a physical contact between the incoming and outgoing athletes and shall be completed within this zone.

RULE 252 MOUNTAIN AND TRAIL RUNNING

1. Course

- (a) The discipline of Mountain and Trail Running takes place on various types of natural terrain (sand, dirt roads, forest paths, single track footpaths, snow trails etc.), and in various kinds of environment (mountains, forests, plains, deserts etc.). Races take place mostly on off-road surfaces; however, sections of paved

surfaces (e.g. asphalt, concrete, macadam etc.) are acceptable as a way to reach or link the trails of the course but should be kept to a minimum. Preferably existing roads and trails should be used.

(b) For Mountain races only, some special exceptions do exist where races are held on a paved surface but are only acceptable when there are large elevation changes on the course.

(c) The entire course shall be clearly marked.

2. Race organization

The Games Committee shall, prior to the race, announce the distance and total ascent / descent of the course which must have been determined. The Games Committee shall also provide a map and detailed profile of the course together with a description of the technical difficulties to be confronted during the race. Time limit and cut-off barriers (if applicable) shall also be announced.

3. Equipment

The use of hiking poles is permitted only if authorized by the Games Committee. The Race Organizers may permit, recommend or impose mandatory equipment (including traction devices such as crampons, micro-spikes, etc.) due to the conditions expected to be encountered during the race. Competitors may carry and use cellular phones during the event.

4. Start

Mountain and Trail races typically have mass starts. Competitors can also start separated by gender or age-related categories. See Rule 242.

Time Trial Mountain Running races have individual start times at various intervals and are considered time trials. The results are ordered by the individual finish times

5. In Trail or Mountain races of 100km or longer, pacing may be permitted if specifically allowed in the race information.

6. Water, Sponging, Refreshment and Aid Stations

Water and other suitable refreshments shall be available at the start and finish of all races. Additional drinking / sponging stations may be provided at suitable places along the course.

For other than national championships, the Games Committee may waive rule 241.2(g) and permit athletes to collect refreshments outside official aid stations.

7. Specific provisions for Mountain Races

(a) The course length may vary from 1km to the Marathon distance.

(b) The average incline should include a minimum of 5% (or 50 meters per kilometer).

(c) Race Types

- a. Classic Mountain Running (up to approximately 20 km) races have mass starts in which all competitors start together or separately by sex or age categories.

- b. Uphill category, where the incline shall be not less than 25%.
 - c. Time Trial Mountain Running races have individual start times at various intervals and are considered time trials. The results are ordered by the individual finish times.
 - d. Mountain Running relay race composition, course distances and course types could vary widely, depending on the natural conditions and the plans of the Organizers. Any course or team combinations, including mixed gender/age group, are possible as long as they are defined and communicated in advance. Distance and elevation gain of each individual leg should respect the parameters of the "Classic" category
8. There shall be no set limit on distance or altitude gain or loss for Trail Races.

ARTICLE V RECORDS

RULE 260 WORLD RECORDS

1. The recognition of World Records is within the jurisdiction of World Athletics. World Athletics Rule CR31 sets forth the conditions for the recognition of World Records. This Rule 260 is intended only as a helpful summary of some of the important provisions and not as an official source.
2. The following categories of World Records are accepted by World Athletics:
 - (a) World Records
 - (b) World U20 Records
3. World Record Application Forms can be downloaded from the World Athletics' web site (<https://www.worldathletics.org/about-iaaf/documents/technical-information>). When a World Record is claimed, the application must be completed without delay and forwarded to the National Office of USATF or to the Chair of the Records Committee. If, after due investigation, the Chair of the Records Committee is satisfied that no reasonable doubt exists as to the validity of the record, the Chair shall so inform the Chief Executive Officer of USATF, who shall have the authority to endorse the application and forward the same to World Athletics. If there are grounds for reasonable doubt as to the validity of the record, the Records Chair shall so inform the Chief Executive Officer, and any communication to World Athletics shall disclose those grounds and shall advise that the application shall be reviewed and ruled upon at the next Annual Meeting of USATF.
4. The application must be accompanied by:
 - (a) The printed program of the meet,
 - (b) The complete results of the event,
 - (c) In case of a track record, the Photo Finish picture and the zero control test where Photo Finish timekeeping was the official recorder of the event,
 - (d) The reaction times, where available, shall be provided in all races where a crouch start and the use of starting blocks is compulsory. For records up to and including 400 meters under World Athletics Rule 261 and World Athletics Rule 263, starting blocks linked to a World Athletics-approved start information system under Rule 161.6 and must have been used and have functioned correctly so that reaction times were obtained.

NOTE: *This Rule does not apply to World U20 Records.*
 - (e) In the case of a field event record, the complete results sheet,
 - (f) In the case of the first application on behalf of an athlete for a U20 record, an official document that confirms the date of birth (a copy of the athlete's passport or birth certificate),

NOTE: *Except for the One Mile Run, World Records are recognized only in the metric running events listed in World Athletics Rule CR32.*

5. Each athlete who sets a World Record, as per Rule 260.2, shall submit to a doping control at the end of the event, to be conducted in accordance with World Athletics Rules and Procedural Guidelines currently in force. The sample(s) collected shall be sent for analysis to a WADA-accredited laboratory and the results sent to World Athletics to be added to other information required for the ratification of the record. If such testing results in a doping violation, or if such testing is not conducted, World Athletics will not ratify this record.
6. Where relevant, the requirements of World Masters Athletics (WMA) shall be complied with to assure appropriate ratification of records recognized by that organization.

RULE 261 NATIONAL RECORDS

1. There shall be six (6) categories of national records as follows:
 - (a) An American Record, which shall be the best performance in an athletics event made by an individual or relay team such that the individual or each member of the relay team, at the time of the performance, is a citizen of the United States and is eligible to represent the United States in all levels of international competition.
 - (b) An American U20 Record, which shall be the best performance in an athletics event made by an individual or relay team such that the individual or each member of the relay team, at the time of the performance, is a citizen of the United States, is eligible to represent the United States in all levels of international competition and is a U20. See Classifications in Rule 141.
 - (c) An American Masters Record, which shall be the best performance made by an individual or relay team such that the individual or each member of the relay team, at the time of the performance, is USA Masters Eligible. Separate records may be established for each of the age divisions listed in Rule 320, and such records shall be kept separately for men and women. See Rule 330.4.
 - (d) An All-Comers Record, which shall be the best performance made in the United States by any competitor or relay team.
 - (e) A Masters All-Comers Record, which shall be the best performance made in the United States by any competitor or relay team in any Masters Division.
 - (f) An American Youth Athletics Record, which shall be the best performance made by an individual or relay team, in any properly sanctioned competition, such that the individual or each member of the relay team, at the time of the performance, is an American citizen and USA Youth Athletics eligible. See Classifications in Rule 141. The record application must include the athlete's current and valid USATF membership number.

NOTE: *There shall be specific national outdoor and indoor records.*

2. When a national record under all categories of Rule 261.1 is claimed, the Association, club, or organization sponsoring or conducting the competition at which the performance was made shall take all necessary steps to complete and submit the appropriate application form.

- (a) Applications for track and field events (including Race Walking events on the track) shall be sent to the attention of National Record Processing at stats@usatf.org. Road record applications and all long-distance record applications shall be sent to Andy Carr, Long Distance Running Recordkeeper; c/o Atlanta Track Club; 201 Armour Dr NE; Atlanta, GA 30324.
 - (b) All Masters and Youth Athletics record applications must be accompanied by proof of birth date. For Youth Athletics acceptable forms of proof include a birth certificate, passport, certified baptismal record, driver's license, or US government identification or equivalent proof. Letters from civil, military, or academic officials are not sufficient. For Masters Athletics, the only acceptable forms of proof are a birth certificate or a passport.
3. Each athlete who achieves a record under Rule 261.1(a) or Rule 261.1(b) in any event shall submit to a doping control to be conducted in accordance with World Athletics Rules and Procedural Guidelines currently in force. In the case of a relay record, all members of the team shall be tested. The sample(s) collected shall be sent for analysis to a WADA accredited laboratory and the results sent, as indicated in Rule 261.2, to be added to other information required for the ratification of the record. If such testing results in a doping violation, or if such testing is not conducted, USATF will not ratify this record.

Records are subject to the following time limits for sample collection:

World Records (World Athletics) – immediately after the event as defined by WADA regulations; International Association of Ultrarunners records – within 24 hours after the event; American Records – within 24 hours after the end of the event.

4. When a Rule 261.1(a) or Rule 261.1(b) record has been equaled or bettered in a competition under the authority of and administratively conducted by the National Office of USATF or World Athletics, an alternative documentation procedure may be used. That record may be ratified by the appropriate Sport Committee based on the official results of the competition, pending the outcome of doping control testing. However, other appropriate documentation shall be required by USATF whenever it has received information creating reasonable doubt regarding the record.
5. When a Masters Record has been equaled or bettered in a WMA Championship, a USATF Masters Indoor or Outdoor National Championship, a USATF Masters Long Distance Running (LDR) Championship or any event listed in Rule 261.4, that record may be ratified based on the official results of that contested event and the submission of correct age documentation, without the need for a formal record application. However, an application and/or other appropriate documentation may be required by the Records Committee whenever it has received information creating some reasonable doubt as to the correctness of the official result.

RULE 262

RULES APPLICABLE TO ALL RECORDS

1. The Records Committee shall investigate every performance submitted for record approval and shall recommend approval or rejection to the appropriate sport committee or to the Mountain/Ultra/Trail Running Council for ultra-marathon track and road races.

2. No record shall be accepted unless it has first been approved by the appropriate sport committee or the Mountain/Ultra/Trail Running Council for ultra-marathon track and road races. No application for a record shall be recommended for approval by the Records Committee unless the committee has received all pertinent required information, as called for by the application or by these rules.

3. Credit for Records:

(a) No record shall be acceptable unless it is set in a competition held in compliance with the rules. A record may be accepted in a handicap race, provided the performance is set in a race in which (1) all competitors start from the same line, (2) no one has started before the competitor claiming the record and (3) the race is timed in accordance with Rule 165.4. At least three competitors, and in relays at least two teams, shall be bona fide and have participated in the event in which the record purportedly was established. In field events, a handicap competition may be combined with the scratch competition. No record shall be acceptable unless it was made in an event that had been sanctioned by USATF, a member organization of USATF, World Athletics, another member Federation of World Athletics, or an organization affiliated with World Athletics (World Masters Athletics and International Association of Ultrarunners) by competitors eligible to compete under World Athletics Rules.

NOTE: *See Rules 320.8, 320.9 and 330.4 for Masters Track and Field conditions.*

(b) For track events over 10,000 meters and road events up to and including the Marathon, multiple events may be contested simultaneously. The athlete must complete the distance entered in order for any intermediate time to be considered as a record.

(c) For races longer than the Marathon, an athlete may compete at a distance shorter than the stated race distance but longer than the Marathon distance. The athlete shall be eligible for records of any standard distance that is completed, even if the stated race distance is not completed. Similarly, a race director may offer several ultramarathon options within the same race with each being considered a bona fide scratch competition.

(d) Records may be set in 'virtual' field events involving individuals competing against each other from physically distant locations provided that the location at which the record-setting performance occurs meets all record requirements.

NOTE: *In meets within allied members of USATF or other recognized organizations, marks made in competition open to two or more athletic organizations may be considered for record listing.*

4. Wind Reading Requirements:

(a) For all records up to and including 200 Meters and 200 Meter Hurdles and for the Long Jump and Triple Jump, if the competition is held outdoors, except for 200 Meter races on an outdoor 200-meter oval, the component of the wind velocity in the direction of the running shall be measured by an approved mechanism that accurately determines such component. This wind information shall be provided on the record application. A non-mechanical wind gauge is required for any performance submitted for ratification as a World Record. If the average velocity of the wind, measured in the direction of the running behind the competitor, exceeds 2.0 meters per second the record will not be accepted, except in the combined events, as per subparagraph (b) below.

- (b) The conditions for recognizing a Combined Event record shall have been complied with in each of the individual events, except that, in events where wind velocity is measured, the average velocity (i.e., the sum of the wind velocities, as measured for each individual event, divided by the number of such events) shall not exceed plus 2.0 meters per second.
5. No record shall be accepted unless the course, distance, or height has been checked with a certified steel tape or bar graduated in centimeters, or by an approved scientific apparatus. In the case of road records, the course must be certified before the race and must meet certification standards as stated in Rule 240. Those standards may include the requirement of a steel tape measurement.
 6. No performance shall be recognized as a record if it has been accomplished in or during a mixed competition of men and women, except field events conducted as provided in Rule 147 and competitions held outside the stadium under Rule 230 or Rule 240.
NOTE: *For Masters exception see Rule 320.8.*
 7. Records made in heats or qualifying trials, in deciding ties, in any event which is subsequently decreed void under the provisions of Rule 125.8, Rule 146.4, Rule 146.5 or Rule 146.7 or in individual events in the combined events, regardless of whether the competitor completes the combined event competition, may be submitted for ratification.
 8. In track events of 10,000 meters or less and in field events, when two or more contestants record the same performance during a single competition, each such contestant shall be entitled to the record. In road races or races over 10,000 meters on the track, only winning contestants are entitled to the record.
 9. When a competitor is disqualified or otherwise is not entitled to a record performance in that competition, another competitor may be given credit for the same record if he/she was not disqualified and was in all respects (including conformity with the appropriate rules of timing and/or measurement) entitled to such record.

RULE 263
RULES APPLICABLE TO TRACK EVENTS

1. Outdoor track records may be made only on a track which conforms to Rule 160, with or without a roof, is not banked and is composed of a substance on which normal running spikes can be used. Indoor running and walking records may be made on any type of surface provided it is indoors. Indoor Records may be made on tracks which conform to Rules 211 and 212. Other records may not.
2. No record claimed for any event in which time is taken shall be allowed unless it has been timed in accordance with Rule 165. For manual times, the watches of the Official Timers shall be exhibited to the Chief Timer and/or the Referee for confirmation of the time recorded. Times recorded by approved Photo Finish devices shall be in accordance with Rule 165.11.
3. When the time taken for a longer distance is better than, or as good as, the record for a shorter distance, the time for the longer distance shall be recognized as the record for the shorter distance.

4. An athlete may set and obtain credit for any number of records in the same race. An athlete shall not, however, be credited with a record at a shorter distance if he or she did not finish the race over the full distance for which the race had been scheduled, except as provided in Rule 262.3(c).
5. For races up to and including the 880yards, only performances timed by an approved Photo Finish device shall be approved as records.
6. The record for an oval track event must be made in a lane where the running line radius does not exceed 50m, except where the bend is formed with two different radii, one of which may exceed 50m as long as it does not account for more than 60 degrees of the 180-degree turn.
7. For outdoor records, in track events of 200 meters or longer, the track must not exceed 440 yards in circumference, and the race must have started on some part of the circumference, except in the Steeplechase event where the water jump is placed outside a normal 400m or 440 yd. track.
8. For indoor records, in track events of 200 meters or longer, the oval track may not have a nominal length of more than 201.2m, 220 yards, in circumference. A record performance may be made indoors on an oval track with a nominal length less than 200m provided that the distance run is within permitted tolerance for the distance.
9. No record may be accepted where the runner in a race run in lanes has been found to be in violation of Rule 163.5. Marks from earlier rounds in an event remain eligible for record consideration. See Rule 145.1.
10. (a) Records for 10,000 meters or a shorter distance contested on a track can be set only on a track which either:
 - i. complies with Rule 160.3, or
 - ii. has been measured 20cm from the white line in accordance with Rule 160.2, provided that the curves have been marked with cones or flags complying in size and placement with Rule 160.3.
- (b) Records for distances longer than 10,000 meters may be accepted as track records provided the inside of the track is marked with a white line and with cones or flags complying with Rule 160.3(b).
- (c) Records for distances longer than 10,000 meters made on tracks that do not comply with Rule 160.3 may be accepted as road records provided they meet all the requirements of Rule 265, including those pertaining to course measurement.
11. For Open Men's and Women's relay events, records shall be recognized in two categories. The first shall be for Olympic, Pan American, and National teams officially representing the USA in international competition, and teams composed of US citizens competing in sanctioned domestic or international events. Records shall also be recognized for the same distances established by relay teams representing a single athletic club or school team. However, where the single club or team record is a superior mark, that record alone shall be recognized.

NOTE 1: *For Masters relay record requirements, see Rule 332.2(f)*

NOTE 2: Pursuant to World Athletics Rules, a World Record in a relay may be made only by a team whose members are citizens of a single member country of World Athletics.

RULE 264
RULES APPLICABLE TO FIELD EVENTS

1. No record claimed for the Hammer, Discus, Shot, Javelin, or Weight shall be allowed unless it has been made with an implement that complies with the specifications for the official implements adopted by World Athletics and USATF or, for Masters records, WMA. The implement must be certified as to weight, measurement, and material on the date of and prior to the competition in accordance with Rule 139.2. If the Referee becomes aware during an event that a record has been equaled or bettered, he shall immediately mark the implement used and undertake a check to ascertain whether it still complies with the Rules or if there has been any change in characteristics. Normally, such implement shall be checked again after the event.
2. Measurements for records in field events shall be made by three field judges, including the Chief Field Judge of that event, under the supervision of the Field Event Referee or Head Field Judge and shall be made using a certified steel tape, certified graduated bar in centimeters or approved scientific measuring device and submitted in meters and centimeters in accordance with Rule 148.
3. When an electronic measurement device is used for a record, the Electronic Measurement Judge for that event shall verify the accuracy of the sighting of the measurement device, read and verify the measurement as displayed on the electronic recording or measurement device, and report the distance to the Chief Field Judge of that event. Three officials which shall include the Chief Field Judge of that event and Chief Electronic Measurement Judge shall verify the mark in the field and the distance as it is displayed on the electronic recording or measuring device and report it to the Field Event Referee or Head Field Judge.
4. The construction of the runway, landing area and/or throwing circle used shall comply with the specifications listed.
5. Records may be credited for more than one performance in a competition, provided that each record so recognized shall have been equal or superior to the best previous performance at that moment.

RULE 265
RULES APPLICABLE TO LONG DISTANCE RUNNING EVENTS

1. (a) No non-winning performance in a road race shall be accepted as a record unless it can be verified (independent of the primary timing systems) that a specific time was recorded for that particular runner. If it cannot be verified that such a time was recorded for the runner, the next slower recorded time that can be verified as being recorded after that runner finishes may be assigned to that runner.
- (b) No performance shall be accepted as an Open American record unless it was timed in accordance with Rule 165. Net timing provided by a Transponder Timing system shall not be accepted for any record set in road events, except as described in Rule 265.8.

2. A winning performance in a race shall be timed in accordance with Rule 165. The winner of each sex division shall be considered to have a winning performance.
3. For track records at distances longer than 10,000 meters, lap sheets must be kept. Such lap sheets must record the total elapsed time for the record applicant for each lap. Only laps for which a time was recorded will be counted as having been completed. Each time entry must be initialed by the recorder, the lap sheets must be verified and signed by the race director, and a legible photocopy (NOT the original copy) of the lap sheets must accompany the record application.
4. For road records:
 - (a) The course must not have a net decrease in elevation from start to finish exceeding 1 part per thousand (i.e., 1m per km).
 - (b) The start and finish of the race must lay no more than 50% of the race distance apart as measured along the straight line between them.
 - (c) For World and National Open Records, the course, measurement and verification shall comply with the provision of World Athletics Rules.
 - (d) For all other records re-measurement may be required if the original measurement has not met criteria established by the RRTC validation chair, approved by the executive committee of the RRTC, and publicly available on the USATF website.
5. For all women's road running records, except Race Walking and Masters records, separate records shall be kept for women-only and mixed competition.
6. In all events that are defined by time, distances will be measured to the nearest lesser full yard or meter only.
7. For road records, a complete set of lap sheets must be kept for any event that is run in three or more loops of the same course. The maintenance and disposition of such lap sheets shall be the same as indicated in paragraph 3, above.
8. Properly rounded net times provided by transponders may be used for American Masters LDR records provided: the competitor wins his/her division as defined for the Masters age groups listed in Rule 320 beginning at age 40 and only including other record eligible competitors; the transponder mat defining the start time is placed completely before the start line; and the transponder mat defining the end time is placed completely after the finish.

RULE 266
RULES APPLICABLE TO RACE WALKING EVENTS

1. Race Walking performances may be accepted as records only if made in competition limited to race walkers.
2. Separate records shall be kept for track and road courses. Records set on a track shall meet all standards applicable to track running events. Records set on road courses shall meet all standards applicable to road running events, including standards pertaining to the measurement and certification of courses. The maximum circuit length shall be the same as those applicable to Championships. See Rule 232.5(a).

3. For records, track races require five Judges and road races require a minimum of six judges, as prescribed in Rule 230.1(e). At least half of these judges shall have USATF National or higher certification, and at least one of these judges must have USATF Master or World Athletics Gold or Silver certification for appropriate events.

RULE 267
EVENTS IN WHICH RECORDS ARE RECOGNIZED

National records shall be recognized only in the events listed in this rule. The events are set forth here by sport committees.

MEN'S TRACK AND FIELD

OUTDOOR EVENTS

100 Meters	1500 Meters	110 Meter Hurdles
200 Meters	2000 Meters	300 Meter Hurdles
400 Meters	3000 Meters	400 Meter Hurdles
800 Meters	5000 Meters	3000 Meter Steeplechase
1000 Meters	10,000 Meters	1 Mile
High Jump	Triple Jump	Hammer Throw
Pole Vault	Shot Put	Javelin Throw
Long Jump	Discus Throw	56-lb. Weight Throw
Pentathlon	Decathlon	Weight Pentathlon
400 Meter Relay (4x100)		3200 Meter Relay (4x800)
800 Meter Relay (4x200)		6000 Meter Relay (4x1500)
1600 Meter Relay (4x400)		440 Meter Shuttle Hurdles (4x110)
4 Mile Relay (4xMile)		1600 Meter Sprint Medley Relay *
Mixed 4x100 Relay		4000 Meter Distance Medley Relay *
Mixed 4x400 Relay		

* **NOTE:** *The 1600 Meter Sprint Medley Relay order: 400-200-200-800 or 200-200-400-800.*

The 4000 Meter Distance Medley Relay order: 400-800-1200-1600 or 800-400-1200-1600 or 1200-400-800-1600 or 1200-800-400-1600.

INDOOR EVENTS

50 Meters	500 Meters	3000 Meters
55 Meters	600 Meters	5000 Meters
60 Meters	800 Meters	1 Mile
200 Meters	1000 Meters	50 Meter Hurdles
300 Meters	1500 Meters	55 Meter Hurdles
400 Meters	2000 Meters	60 Meter Hurdles
High Jump	Long Jump	Shot Put
Pole Vault	Triple Jump	35-lb Weight Throw
Pentathlon	Heptathlon	
800 Meter Relay (4x200)		3200 Meter Relay (4x800)
1600 Meter Relay (4x400)		6000 Meter Relay (4x1500)
1600 Meter Sprint Medley Relay*		4000 Meter Distance Medley Relay*

* **NOTE:** *The 1600 Meter Sprint Medley Relay order: 400-200-200-800 only.*

The 4000 Meter Distance Medley Relay order: 400-800-1200-1600 or 800-400-1200-1600 or 1200-400-800-1600.

U20 OUTDOOR EVENTS

100 Meters
200 Meters
400 Meters
800 Meters
1000 Meters

1500 Meters
3000 Meters
5000 Meters
10,000 Meters

110 Meter Hurdles
300 Meter Hurdles
400 Meter Hurdles
3000 Meter Steeplechase
1 Mile

High Jump
Pole Vault
Long Jump

Triple Jump
Shot Put
Discus Throw

Hammer Throw
Javelin Throw

Decathlon

Mixed 4x100 Relay
400 Meter Relay (4x100)

Mixed 4x400 Relay
1600 Meter Relay (4x400)

U20 INDOOR EVENTS

60 Meters
200 Meters
400 Meters
800 Meters

1000 Meters
1500 Meters
3000 Meters
5000 Meters

60 Meter Hurdles
1 Mile

High Jump
Pole Vault

Long Jump
Triple Jump

Shot Put

Heptathlon

WOMEN'S TRACK AND FIELD OUTDOOR EVENTS

100 Meters
200 Meters
400 Meters
800 Meters
1000 Meters

1500 Meters
2000 Meters
3000 Meters
5000 Meters
10,000 Meters

100 Meter Hurdles
300 Meter Hurdles
400 Meter Hurdles
2000 Meter Steeplechase
3000 Meter Steeplechase
1 Mile

High Jump
Pole Vault
Long Jump

Triple Jump
Shot Put
Discus Throw

Hammer Throw
Javelin Throw

Heptathlon

Pentathlon

Decathlon

Weight Pentathlon

400 Meter Relay (4x100)
800 Meter Relay (4x200)
1600 Meter Relay (4x400)
4 Mile Relay (4xMile)
800 Meter Sprint Medley Relay *
Mixed 4x100 Relay

3200 Meter Relay (4x800)
6000 Meter Relay (4x1500)
400 Meter Shuttle Hurdles (4x100)
1600 Meter Sprint Medley Relay *
4000 Meter Distance Medley Relay *
Mixed 4x400 Relay

* **NOTE:** The 800 Meter Sprint Medley Relay order: 100-100-200-400 only.

The 1600 Meter Sprint Medley Relay order: 400-200-200-800 or 200-200-400-800.

The 4000 Meter Distance Medley Relay order: 400-800-1200-1600 or 800-400-1200-1600 or 1200-400-800-1600 or 1200-800-400-1600.

INDOOR EVENTS

50 Meters	500 Meters	5000 Meters
55 Meters	600 Meters	1 Mile
60 Meters	800 Meters	50 Meter Hurdles
200 Meters	1000 Meters	55 Meter Hurdles
300 Meters	1500 Meters	60 Meter Hurdles
400 Meters	3000 Meters	
High Jump	Long Jump	Shot Put
Pole Vault	Triple Jump	20-lb Weight Throw

Pentathlon

800 Meters (4x200)	3200 Meters (4x800)
1600 Meters (4x400)	6000 Meters (4x1500)
	4000 Meter Distance Medley Relay *

* **NOTE:** The 4000 Meter Distance Medley Relay order: 400-800-1200-1600 or 800-400-1200-1600 or 1200-400-800-1600.

U20 OUTDOOR EVENTS

100 Meters	1500 Meters	100 Meter Hurdles
200 Meters	3000 Meters	300 Meter Hurdles
400 Meters	5000 Meters	400 Meter Hurdles
800 Meters	10,000 Meters	2000 Meter Steeplechase
		3000 Meter Steeplechase
		1 Mile
High Jump	Triple Jump	Hammer Throw
Pole Vault	Shot Put	Javelin Throw
Long Jump	Discus Throw	

Heptathlon

Mixed 4x100 Relay
400 Meter Relay (4x100)

Pentathlon

Decathlon

Mixed 4x400 Relay
1600 Meter Relay (4x400)

U20 INDOOR EVENTS

60 Meters	1000 Meters	60 Meter Hurdles
200 Meters	1500 Meters	1 Mile
400 Meters	3000 Meters	
800 Meters	5000 Meters	
High Jump	Long Jump	Shot Put
Pole Vault	Triple Jump	Pentathlon

MEN'S AND WOMEN'S RACE WALKING TRACK

3000 Meters	25,000 Meters	100 Miles
5000 Meters	30,000 Meters	1 Hour
10,000 Meters	35,000 Meters	2 Hours
15,000 Meters	40,000 Meters	Half-Marathon
20,000 Meters	50,000 Meters	Marathon
	100,000 Meters	

OUTDOOR ROAD

5 km	25 km	100 km
10 km	30 km	100 Miles
15 km	35 km	Marathon Mixed Relay
20 km	40 km	Half-Marathon
	50 km	Marathon

INDOOR TRACK

1500 Meters	5000 Meters	1 Mile
3000 Meters	10,000 Meters	2 Miles

U20 TRACK

3000 Meters	15,000 Meters	25,000 Meters
5000 Meters	20,000 Meters	1 Hour
10,000 Meters		Half-Marathon

U20 OUTDOOR ROAD

5 km	15 km	25 km
10 km	20 km	Half-Marathon

U20 INDOOR TRACK

1500 Meters	5000 Meters	1 Mile
3000 Meters		

MEN'S AND WOMEN'S LONG DISTANCE RUNNING – DIVISIONS: 16 - 19*, OPEN AND MASTERS

Track Events

15,000 Meters	100,000 Meters	1 Hour
20,000 Meters	200,000 Meters	2 Hours
25,000 Meters	10 Miles	12 Hours
30,000 Meters	50 Miles	24 Hours
50,000 Meters	100 Miles	

Road Events

5 km	25 km	10 Miles
8 km	30 km	50 Miles
10 km	50 km	100 Miles
12 km	100 km	12 Hours
15 km	200 km	24 Hours
20 km	1 Mile	Half-Marathon
	4 Mile	Marathon

Road and/or Track Events

1000 Miles	48 Hours	144 Hours
------------	----------	-----------

* For 18 and 19: Ultra-Marathon and 2 hours and longer.

MASTERS TRACK AND FIELD

1. All events listed in Rule 331
2. All events listed in this rule for Men's Race Walking.
3. Additional event for Indoor Track and Field: Mile.
4. Additional events for Outdoor Track and Field: Mile, 3000 Meters, 1500 Meter Race Walk.

NOTE: See Rule 320.8 for additional requirements.

YOUTH ATHLETICS
All events listed in Rule 301

RULE 268
ADDITIONAL RECORDS

1. Games, championships, meeting and other similar records may be established by the body having control over the competition or the organizing committee.
2. The record should recognize the best performance achieved at any edition of the applicable competition in accordance with the Rules, with the exception that wind velocity readings may be ignored, unless it is specifically provided otherwise in the applicable entry material/Technical Information for the competition.

RULE 269
NOTEWORTHY PERFORMANCES

1. A performance may be recorded as a "Noteworthy Performance" if so approved by the appropriate sport committee.
2. A performance made indoors on a track measuring more than 220 yards, if otherwise eligible for indoor record listing, and if it is equal to or better than the American or All-Comers Record in such event, may be listed as a Noteworthy Performance, if so approved by the appropriate sport committee.

**ARTICLE VI
SPECIAL PROGRAMS
SECTION I
YOUTH ATHLETICS**

**RULE 300
GENERAL RULES**

1. (a) Articles I (Section 1) and Articles II-V of the Rules of Competition of USATF and Classifications shall apply to Youth Athletics competition, except to the extent that such rules are in conflict with this Article VI, Section I. If there is a conflict, Article VI Section I shall supersede any other provisions of the USATF Rules. All athletes must be members of USATF to participate in the Association Championship. If the Association starts with qualification meets, competitors must be USATF members at the qualification round of competition.
- (b) The Youth programs are divided into divisions for boys and divisions for girls. The athlete’s year of birth shall determine the division in which the athlete shall compete. With each succeeding year each division shall be adjusted as shown in the table below:

	2026	2027	2028	2029
8 and under Division	2018+	2019+	2020+	2021+
9-10 Division	2016-2017	2017-2018	2018-2019	2019-2020
11-12 Division	2014-2015	2015-2016	2016-2017	2017-2018
13-14 Division	2012-2013	2013-2014	2014-2015	2015-2016
15-16 Division	2010-2011	2011-2012	2012-2013	2013-2014
17-18 Division	2008-2009	2009-2010	2010-2011	2011-2012
High School Division & 15-18 USATF Club Relays Only (Indoor National Championship Only)				
High Performance/Emerging Athlete Division (15-16, 17-18 Divisions only)				

- (c) Athletes must be at least seven (7) years of age on December 31 of the current year to compete at the Youth Athletics or Junior Olympic National Championship.
- (d) Athletes who are still eighteen (18) years of age through the final day of the National Junior Olympic Track and Field Championship shall be eligible to compete in the 17-18 year old division through that meet. This extended eligibility does not apply to cross country events.
- (e) Competitors must compete in their own divisions only. No athlete may compete in younger or older divisions in individual, relay, or team events. USATF Club team members must be from the same Club and High School team members must be from the same High School.

NOTE: *When, as determined by the Referee, there is an insufficient number of competitors reporting within an age group for a track event, such that separate races eliminate the element of competition, a mixed age group race of the same gender or mixed gender may be authorized. The finish order within each age and gender group shall be separate for all scoring and awards*

- (f) In track and field, a competitor in the 8 and under, 9-10 or 11-12 year old divisions may enter a maximum of three events. Competitors in the 13-14, 15-16 or 17-18 year old divisions may enter a maximum of four events. These limitations include relays, but not combined events or road races. Entry in a relay, either as a primary or an alternate member, will be considered an entry for the purpose of this rule.
- (g) Participation in Youth Athletics Championships and Junior Olympic programs shall be restricted to United States citizens, aliens living in the United States, and foreign exchange students.
- (h) The High Performance/Emerging Athlete Division shall include only individual and relay events specifically selected by the National Youth Executive Committee. Entry into this Division shall be based on standards only. The effective date for this Rule was January 1, 2026.
- (i) A Youth Athlete must compete in the Association of residence in which they permanently reside. 'Permanent Residency' is defined as the address of residence of the youth athlete's parent/legal guardian on the day of the close of registration. Proof of residency can be provided by Tax Statements, or utility bills at the place of residency. Youth athletes can compete in their Association of Permanent Residency as an unattached athlete or as a member of a club and represent the said club by wearing a team uniform and participating on a relay. The following are exceptions to this rule:
 - i. Athletes that live with one custodial parent/legal guardian in the summer in one Association and another custodial parent/legal guardian in another Association during the school year, shall be considered permanent residents of both Associations. These athletes may choose to only have one membership number under one Association, but will have the right to run with a different club in the residence of summer and have all rights and privileges of that Association. Proof of legal guardianship may be requested for proof of residency. It shall be the sole responsibility of the applying athlete to secure and furnish all necessary documentation to substantiate any request to consider application of this rule.
 - ii. Athletes that have no parent/legal guardian residing in an Association may compete in that Association for 'just cause' with the approval of both the Youth Chair and Membership Chair of both the Association of 'Permanent Residency' and the association of 'Non-Residency'. Non-Residence athletes may not represent a club or wear a club uniform in the Association of 'Non-Residency'.
 - iii. Athletes that have no parent/legal guardian residing in an Association may compete in a bordering Association for 'just cause' provided that:
 - (1) The team they are requesting a transfer to, in the bordering association, is less than 50 miles from their original Association of Permanent Residency.
 - (2) The athlete can commute daily to practice with that team.
 - (3) There are no other USATF teams in the Association of Permanent Residency.

- (4) It shall be the sole responsibility of the applying parent to secure and furnish all necessary documentation to substantiate any request to consideration of application of this rule.

The athlete must have the prior approval in writing of both the Youth Chair and Membership Chair of both the Association of 'Permanent Residency' and the Association of 'Non-Residency', and placed on file in the National office.

- (j) Proof of date of birth shall be submitted to the athlete's Association immediately after becoming a USATF member. All athletes shall be required to have "Proof of Age Verified" prior to close of registration of the first level of competition, whether it is the Association Championship or the Preliminary Qualifying Meet, and at all Youth Athletics competitions above this level. The form of proof shall be a copy of a birth certificate, passport, certified baptismal record, driver's license, or United States government identification. Where the issuing Association has validated the athlete's competition entry form or membership card with "Proof of Age Verified," or other wording to that effect, the validated entry form or membership card becomes acceptable proof of age. When using online registration, "Proof of Age Verified" must be downloaded from the USATF membership data base prior to close of registration of the first level of competition. Letters from school or recreation offices shall not be considered as proof.
- (k) Penalties may be considered by Associations and by the National Athletics Board of Review for participation by an athlete in an improper age division. These penalties may be applied to athletes, coaches, and clubs involved.
- (l) In order to promote participation in Youth Athletics Competition, entry fees should be kept as low as possible. The National Youth Athletics Division may set maximum fees for Youth Athletics competitions at Association, Regional, and National levels.

2. **National Championships -**

- (a) The Division's Chair or their designee(s) shall serve as the Meet Referee at all National meets. The Referee shall be a National or Master certified official. The Division's Chair shall have the authority and be responsible to appoint the Competition Director and Event Presentation Manager.
- (b) The USATF National Junior Olympic Cross Country meet shall serve as the Youth Athletics National Championship.
- (c) Qualifying standards and procedures may be established for National Youth Championships and for all qualifying competitions to such Championships by the Youth Executive Committee.
- (d) In track and field, National Championships shall be contested on a 400 meter track with no fewer than eight lanes and having a raised inner curb in conformance with Rule 160.3(a).
- (e) A finish recording system, as described in Rule 165, producing a photograph or image depicting place and time shall be used for all events contested on the track.

- (f) Approved measuring equipment shall be used to verify the legality of throwing implements to be used in the competition.
 - (g) Throwing implements, starting blocks, and relay batons shall be furnished by the meet host.
3. **Association and Regional Championships -**
- (a) The meets shall be under the guidance of the Youth Athletics Division through their respective Youth Chairs (Association Championships) and Regional Coordinators (Regional Championships).
 - (b) The Championships shall be contested in accordance with Rules 300.2, (e), (f) and (g). Where possible, the meet should be contested on tracks that comply with rule 300.2(d). However, tracks without a curb may have cones laid out as described in Rule 160.3 provided the track has been measured 20cm from the white line in accordance with Rule 160.2.
 - (c) The Association Youth Chair, Regional Coordinator or their designee(s) shall serve as or appoint the Meet Referee of their respective meets. The Referee shall be a certified official for Association Championships and a National or Master Certified official for Regional Championships. The Association Youth Chair or Regional Coordinator shall have the authority and be responsible to appoint the Meet / Competition Director and the Event Presentation Manager.
NOTE: *The Youth Chair or Regional Coordinator may serve as a Referee, but cannot serve in a dual capacity.*
 - (d) Regional Championships and, whenever possible, Association Championships, shall be Photo Finish timed. If the Photo Finish timer fails or is not used, all affected meet results shall clearly indicate any times that are not Photo Finish.
4. **Region / Associations -**
- 1. Adirondack, Connecticut, Long Island, Maine, New York, and New England
 - 2. Mid-Atlantic, New Jersey, Niagara, and Three Rivers
 - 3. North Carolina, Potomac Valley, and Virginia
 - 4. Florida, Georgia, and South Carolina
 - 5. Kentucky, Lake Erie, Michigan, Ohio, and West Virginia
 - 6. Alabama, Southern, and Tennessee
 - 7. Illinois and Indiana
 - 8. Dakotas, Iowa, Minnesota, Nebraska, and Wisconsin
 - 9. Arkansas, Missouri Valley, Oklahoma, and Ozark
 - 10. Arizona, Border, Colorado, New Mexico
 - 11. Montana, Snake River, Utah and Wyoming
 - 12. Gulf, South Texas, Southwestern, and West Texas
 - 13. Alaska, Inland Northwest, Oregon, and Pacific Northwest
 - 14. Central California, and Pacific
 - 15. Hawaii, Nevada, San Diego Imperial, and Southern California
 - 16. National Junior Olympic Championship Host Association, the Department of Defense Dependent Schools (DODDS) Europe and Pacific

RULE 301 TRACK AND FIELD EVENTS

The events listed below are included in the National Championship. (Combined Events, where different from those described in Rule 200, are held in the event order indicated. Weights of implements are identical to those applicable to individual events in the respective age groups.)

8 AND UNDER DIVISION

100 Meter Dash	1500 Meter Run	Long Jump
200 Meter Dash	4x100 Meter Relay	Shot Put - 2kg
400 Meter Dash	4x400 Meter Relay	Mini Javelin - 300g
800 Meter Run		

9-10 DIVISION

100 Meter Dash	High Jump	4x400 Meter Relay
200 Meter Dash	Long Jump	Triathlon: Shot Put - 6 lb.
400 Meter Dash	Shot Put - 6 lb.	High Jump
800 Meter Run	Mini Javelin - 300g *	200 Meter - G
1500 Meter Run	Aero Javelin - 250g *	400 Meter - B
1500 Meter Race Walk	4x100 Meter Relay	

* Aero Javelin replaced Mini Javelin effective January 1, 2026.

11-12 DIVISION

100 Meter Dash	80 Meter Hurdles - 30"	4 x 400 Meter Relay
200 Meter Dash	Long Jump	4 x 800 Meter Relay
400 Meter Dash	High Jump	Pentathlon: 80m Hurdles
800 Meter Run	Shot Put - 6 lb.	Shot Put - 6 lb.
1500 Meter Run	Discus -1kg	High Jump
3000 Meter Run	Aero Javelin - 450g	Long Jump
1500 Meter Race Walk	4 x 100 Meter Relay	800 Meter Run - G
		1500 Meter Run - B

13-14 DIVISION

	4 x 400 Meter Relay	
100 Meter Dash	4 x 800 Meter Relay	Discus -1kg
200 Meter Dash	100 Meter Hurdles - B-36"	Pole Vault
400 Meter Dash	100 Meter Hurdles - G-30"	Javelin - 600g
800 Meter Run	200 Meter Hurdles - 30"	Pentathlon: 100m Hurdles
1500 Meter Run	High Jump	Shot Put - B 4kg, G 6 lb.
3000 Meter Run	Long Jump	High Jump
2000 Meter Steeple – 30"	Triple Jump	Long Jump
3000 Meter Race Walk	Shot Put - B-4kg	800 Meter Run - G
4 x 100 Meter Relay	Shot Put - G-6 lb.	1500 Meter Run - B

15-16 DIVISION

100 Meter Dash	4 x 400 Meter Relay	Triple Jump
200 Meter Dash	4 x 800 Meter Relay	Shot Put - B-12 lb., G-4kg
400 Meter Dash	110 Meter Hurdles - B-39"	Discus - B-1.6 kg, G-1kg
800 Meter Run	100 Meter Hurdles - G-33"	Javelin - B-800g, G- 600g
1500 Meter Run	400 Meter Hurdles - B-36"	Hammer - B-12lb., G-4kg
3000 Meter Run	400 Meter Hurdles - G-30"	Decathlon - B
2000 Meter SC B-36, G-30	High Jump	Heptathlon -G
3000 Meter Race Walk	Pole Vault	Mixed Gender Relays ***
4 x 100 Meter Relay	Long Jump	

*** 4x100, 4x400, and 4x800 are authorized with alternating genders for relay legs in each.

17-18 DIVISION

100 Meter Dash	4 x 400 Meter Relay	Long Jump
200 Meter Dash	4 x 800 Meter Relay	Triple Jump
400 Meter Dash	110 Meter Hurdles - B-39"	Shot Put - B-12 lb., G-4kg
800 Meter Run	100 Meter Hurdles - G-33"	Discus - B-1.6 kg, G-1kg
1500 Meter Run	400 Meter Hurdles - B-36"	Javelin - B-800g, G- 600g
3000 Meter Run	400 Meter Hurdles - G-30"	Hammer - B-12lb., G-4kg
2000 Meter SC B-36, G-30	High Jump	Decathlon - B
3000 Meter Race Walk	Pole Vault	Heptathlon G
4 x 100 Meter Relay	Mixed Gender Relays ***	

*** 4x100, 4x400, and 4x800 are authorized with alternating genders for relay legs in each.

Indoor Events

7-8	9-10	11-12	13-14	15-16	17-18	High School	USATF Club relays 15-18
55m	55m	55m	55m	55m	55m		
200m	200m	200m	200m	200m	200m		
400m	400m	400m	400m	400m	400m		
800m	800m	800m	800m	800m	800m	4x800**	4x800**
1500m	1500m	1500m	1500m	1500m	1500m	DMR**	DMR**
	1500m	3000m	3000m	3000m	3000m		
	RW	RW	RW	RW	RW		
4x200	4x200	4x200	4x200	4x200	4x200	4x200 **	4x200**
4x400	4x400	4x400	4x400	4x400	4x400	4x400 **	4x400**
		55m H	55m H	55m H	55m H		
						55mH shuttle relay **	55mH shuttle relay **
LJ	LJ	LJ	LJ	LJ	LJ		
			TJ	TJ	TJ		
SP-2k	SP-6lb	SP-6lb	SP-B4k	SP-B12#	SP-B12#		
	HJ	HJ	G 6lb	G 4k	G 4k		
			HJ	HJ	HJ		
			PV	PV	PV		
				WT-B25#	WT-B25#		
				G 20#	G 20#		

** These events are for Indoor Nationals ONLY

RULE 302 REGULATIONS AND SPECIFICATIONS

1. General

No athlete may be advanced in the competition without having successfully qualified through required qualification rounds.

2. Track Events

(a) In one-day meets at the Association level, all events may be run as timed finals.

(b) The Games Committee may elect, in events of 800 meters and longer, and all relays, to use a qualification method based upon place and time in order to eliminate qualification rounds beyond one.

(c) In Association and regional meets where all rounds are held on one day, and the competitors in the 100, 200, or hurdles advance directly to a final, the final may be run at the time of the scheduled preliminary.

- (d) False starts are called on individuals, not on the field. For the 8 and under, 9-10, 11-12 and 13-14 year old divisions, for a first false start by a competitor, a yellow and black (diagonally halved) card shall be raised in front of the respective competitor(s), and when lane markers are being used, a corresponding indication should be placed on the respective lane marker(s). For a second false start, the respective competitor(s) shall be disqualified.

NOTE: *15-16 and 17-18 year old age divisions follow Rule 162.13.*

- (e) Starting blocks: Athletes in the 15-16 and 17-18 year old divisions shall, in accordance with Rules 161, be required to use starting blocks and a crouch position for all events up to and including the 400 Meter Runs and the first leg of all relays where that leg does not exceed 400 meters. For athletes in the 8 and under, 9-10, 11-12 and 13-14 year old divisions, the general rules regarding the use of starting blocks and stance are waived; the use of starting blocks and stance is within the discretion of the competitor. The setting of a competitor's starting blocks other than by the competitor or an individual designated by the starter is prohibited.
- (f) Lane-line infringement violations are defined in Rule 163.5
- (g) In sprint relays, the outgoing runners may place a suitable material as determined by meet management on the track. If other than adhesive tape, then it must be made clear in the meet information (passport) and meet management must supply the suitable material to be used to all teams.
- (h) The 'honest participation' rule provided in Rule 142.4 and Rule 142.5 shall not be applicable to Youth Athletics.
- (i) Whenever possible, and especially at Regional and National meets, lane staggers with one competitor per lane shall be used as follows:

800m Run, 4x800m Relay	One-turn stagger
4x400m Relay	Three-turn stagger
- (j) When there are more lanes than athletes in laned events, Rule 166.2(f) Note 1 shall apply unless the Games Committee, before the competition, decides otherwise.

3. Relays

- (a) The procedure for entering a relay is in the Youth Training and Development Manual and the meet entry/Technical Information. Failure to comply with the procedure may result in disqualification.
- (b) A Relay team shall consist of four (4) members.
- (c) For 15-16 and 17-18 age division mixed relays; the competition order is:
4x800m mixed relay - boy / girl / boy / girl
4x400m mixed relay - boy / girl / boy / girl
4x100m mixed relay - girl / girl / boy / boy
- (d) Participation of relay teams shall be limited to those clubs that hold a valid club membership in USATF.

- (e) All participants on a team shall wear a top of the same color. At Regional and National Championships, all participants on a team shall wear a top of a same color as well as bottoms of a same color. The Games Committee shall assign an individual to review colors of team uniforms in the clerking area.
- (f) An athlete may drop an individual event to compete on a relay as long as the athlete has not competed in any round of that event. A 'no show' does not constitute a drop in that event. A change form must be submitted at registration 1 hour prior to the scheduled start of the event being dropped.

Youth Athletics Nationals and Junior Olympics

- (g) Any athlete entered and listed in the USATF membership database with the club in the same division/sex is eligible for that relay team roster. The deadline for membership entry is the entry deadline of the meet, whether it is the Association championship or preliminary meet, as specified in the entry material/Technical Information but not later than the first (1st) round of competition.
- (h) Relay team entry requires a minimum of 4 and a maximum of 6 listed eligible athletes.
- (i) All competitors listed on the official online roster are eligible to compete if they are entered in the meet in individual events or other relays. If an individual is not entered in the meet by either of the above methods stated above, that individual shall be entered in the online entry as 'other' in the event section. An additional cost equal to the cost of a single event entry may be charged for each member entering by this method.

4. Hurdle and Steeplechase Specifications

- (a) Hurdle specifications are as follows:

OUTDOOR EVENTS						
Division	Distance	Hurdles	Height	To First	Interval	To Finish
11-12 GB	80m	8	30"	12m	7.5m	15.5m
13-14 Girls	100m	10	30"	13m	8.5m	10.5m
13-14 Boys	100m	10	36"	13m	8.5m	10.5m
15-16/17-18 G	100m	10	33"	13m	8.5m	10.5m
15-16/17-18 B	110m	10	39"	13.72m	9.14m	14.02m
13-14 B & G	200m	5	30"	20m	35m	40m
15-16/17-18 G	400m	10	30"	45m	35m	40m
15-16/17-18 B	400m	10	36"	45m	35m	40m

INDOOR EVENTS						
Division	Distance	Hurdles	Height	To First	Interval	To Finish
11-12 GB	50m	4	30"	12m	7.5m	15.5m
11-12 GB	55/60m	5	30"	12m	7.5m	13m/18m
13-14 G	55/60m	5	30"	13m	8.5m	8m/13m
13-14 B	55/60m	5	36"	13m	8.5m	8m/13m
15-18 G	55/60m	5	33"	13m	8.5m	8m/13m
15-18 B	55/60m	5	39"	13.72m	9.14m	4.72m/9.72m

High School G	55/60m Shuttle	5	33"	13m	8.5m	8m/13m
High School B	55/60m Shuttle	5	39"	13.72	9.14m	4.72m/9.72m

(b) The Steeplechase distance for 13-14, 15-16 and 17-18 year old Divisions is 2000 meters.

NOTE: For steeplechase course and barrier specifications, see Rule 169.2 and Rule 169.3.

5. Field Events

- (a) Measurements shall be in accordance with the general rules of competition of USATF.
- (b) The horizontal jumps and throws may be contested using flights. Flights will be composed on the basis of the submitted qualifying marks and shall be arranged with the highest qualifying flight competing last.
- (c) At meets other than Association, Regional and National Championships the Games Committee may use a four-attempt rule in lieu of three preliminary and three final attempts for finalists in the horizontal jumps and throws. Use of the four-attempt option must be stated prior to the beginning of the competition.
- (d) In the Long Jump, more than one take-off board may be used between 1m and 4.5m behind the landing area. In the Triple Jump, more than one take-off board may be used between 7 and 13m from the landing area. (Suggestions: 15-16/17-18 Boys at 10m; 15-16/17-18 Girls at 8m; 13-14 Boys and Girls at 7m). The take-off board may consist of material other than wood. More than one take-off board may be used with an indicator (such as orange cones) placed at both sides of the take-off board. Each jumper must declare prior to each jump which board he/she will use.
- (e) In the Shot Put, Discus, and Hammer a 34.92-degree sector shall be used and the throwing circle may be painted instead of metal. See Rules 187.1(b) and 187.22.
- (f) The number of spikes and/or cleats on shoes for the javelin shall not be limited where the runway has a natural or AstroTurf-type surface.
- (g) Privately owned implements shall be exempt from the loss-of-identity provision in Rule 187.10.
- (h) In the Javelin Throw, the measurement of the throw shall be made from the nearest edge of the first point of contact made by the javelin in the sector to the inside circumference of the arc or foul line, measured along a line from the contact point of the tip, tail, or grip to the center of the circle of which the arc is a part.
- (i) In order to stage a Youth Athletics hammer or discus competition a protective cage is required (see Rule 190). If there is no cage or the cage is in such condition that it is not considered safe by the appropriate referee or his designee, then the events shall not be held.

- (j) In all age divisions of the High Jump and Pole Vault an athlete may be assisted in establishing the location of their marks prior to the start of competition. Rule 181.3 will apply, except that no more than three marks may be used, and such marks cannot exceed 3 inches in length. In the Long Jump, athletes in the 8 and Under and 9-10 age divisions may be assisted by a designated person in establishing the location of their marks prior to the start of competition.

NOTE: *At all levels of competition, the individual providing assistance shall have a field-of-play credential issued by meet management. This assistance and 'start of competition' shall be flight specific.*

- (k) In the Pole Vault, a pole vault box collar pad complying with the current ASTM specification shall be used.
- (l) In the Pole Vault, movement of the uprights, Rule 183.1(a), shall be limited to the area between 45cm and 80cm from the stop-board in the direction of the landing surface.
- (m) The practice of "tapping" (physically assisting) vaulters during their warm-ups is prohibited.
- (n) A competitor shall not use a training pole, a pole which is improperly marked or a pole rated below his/her weight during warm-up or competition. Prior to warm-up, the Field Event Referee or designee shall inspect each pole to be used in competition to verify that the poles are legal equipment. The competitor's weight shall be at or below the manufacturer's pole rating. It is the responsibility of the coach or parent to verify the competitor will use a legal pole rated at or above his/her weight.

NOTE: *The manufacturers shall include on each pole a pole rating that shall be a minimum of 3/4 inch in a contrasting color located within or above the top hand hold position with the position being determined by the manufacturer.*

- (o) In the National Youth Athletics Championship and the National Junior Olympic Championship the starting heights in the High Jump and Pole Vault shall be 10cm and 30cm, respectively, below the Youth Outdoor Performance Standard established by the Youth Athletics Division at the USATF Annual Meeting. In the Regional Junior Olympic Championship, the starting heights in the High Jump and Pole Vault shall be 20cm and 60cm, respectively, below the Youth Outdoor Performance Standard. Increment increases in all stated Championships shall be 5cm in the High Jump and 15cm in the Pole Vault.
- (p) When a High Jump or Pole Vault competitor is excused to participate in a running event, a reasonable time limit shall be established by the Games Committee or delegated to the affected Field Event Judge. If the competitor has failed to return in the allotted time, and all other remaining competitors have passed, failed or cleared the existing height, the crossbar shall be raised to the next height and the judge will automatically pass the excused competitor to the new height. If the competitor has failed to return and the competition has otherwise concluded, the judge shall automatically pass the excused competitor and only raise the bar once to the next height before using the forfeiting procedure in Rule 181.6.
- (q) When a Horizontal Jumps or Throws competitor is excused to participate in a running event the competitor must return before the conclusion of all other

preliminary attempts if excused during the preliminaries, or before the conclusion of all other final attempts if excused during the finals. Failure to return within the allocated period shall result in forfeiture of missed attempts. In both the preliminaries and the finals, the head event judge may allow attempts to be taken in succession before a competitor is excused, and make-up attempts may be taken in succession and out of order upon legally returning to the event.

(r) In the High Jump and Pole Vault, each competitor who has not taken an initial trial in at least one hour from the time of the first trial of the event competition, shall be permitted no more than two run-throughs within a minute and a half in the high jump or two minutes in the pole vault. Such run-throughs shall be taken at a height change under the direction of the event official without a crossbar or bungee in place. The competitor using this provision shall make at least one attempt at this height.

(s) In a field event, the viewing of images of previous trials by a competitor is forbidden.

NOTE: *Athletes competing in an event on the infield may not, during the competition, cross to the outside of the track.*

(t) Warm-ups at the event venue shall not be allowed unless supervised by an event official and the event venue has been declared open by the Chief Event official with direction from the Meet Director. Warm-up approaches in the long jump, triple jump, javelin and pole vault may only be taken in the direction in which the event is contested. Running in the opposite direction either on or adjacent to the runway is forbidden.

6. Combined Events

(a) Combined Events shall be held at the National Junior Olympic Championship. Combined Events may or may not be held at the National Youth Athletics Championship in a particular year as approved by the National Youth Executive Committee. If Combined Events are not held at that Championship, they may be held separately.

(b) Rule 200 shall be followed unless otherwise provided herein.

(c) Boys hurdle races shorter than 110 meters are scored from the men's 110 Meter Hurdles tables. Girls hurdle races shorter than 100 meters are scored from the women's 100 Meter Hurdles tables. Times for the 11-12 Boys' 80 Meter Hurdles shall be multiplied by 1.13 prior to entering the tables; for the 11-12 Girls' 80 Meter Hurdles, multiply by 1.07.

(d) It is suggested that even-numbered lanes be used for hurdle events.

(e) The increments for the Pole Vault will be 15cm and the High Jump 5cm. The additional warm-up provisions of Rule 302.5(r) shall apply.

(f) The heptathlon must be contested over two days.

(g) If groups are drawn in accordance with Rule 200.5, these groupings shall continue throughout the competition unless the Referee shall believe it desirable to rearrange any group or groups.

- (h) In the 800 Meter Run, the maximum number per heat shall be 12. When the number of competitors exceeds the number of lanes, the excess competitors shall share the even-numbered lanes starting from lane 8 working into lane 2. In the 1500 meters, the maximum number per heat shall be 24.
- (i) At the National Junior Olympic Championship, when more than one flight is required in the Long Jump, Shot Put, Discus and Javelin, a minimum of 20 minutes should be allowed between flights.

RULE 303
REGULATIONS FOR LANES AND HEATS

- 1. The method of advancement in all meets shall be published prior to the start of the meet. Any changes to the printed method shall be announced prior to the competition. Heats shall be formed according to the following regulations:
 - (a) The declared contestants will be assigned to preliminary heats in the order in which their names are listed on the performance list, working from left to right and then right to left. The only exception is when this procedure would cause unequal distribution of members from the same club. In this event, the slower athlete should be moved to another heat, interchanged with a competitor with the nearest comparable time as listed in that heat.
 - (b) In events run entirely or partially in lanes, only one participant shall occupy a lane, except as provided in (c), below.
 - (c) The 800 Meters and the 4x800 Meter Relay shall be run with a one-turn stagger. The maximum number in all heats prior to the final shall be 12. When the number of competitors exceeds the number of lanes, the excess competitors shall share the even-numbered lanes starting from lane 8 and working into lane 2 (Hip number 9 is placed in lane 8; Hip 10 is placed in lane 6; Hip 11 is placed in lane 4 and hip 12 is placed in lane 2). Eight (8) competitors (9 on a 9-lane track) shall advance to the final of the 800 Meter Run. At Association and Regional meets, timed finals may be run with no more than 12 per section.
 - (d) At the National Youth Athletics and National Junior Olympic Championship in the 800 Meter Run, without regard to the number of athletes entered, shall be contested as two rounds with the top 8 times advancing to the final. The 4x800 Meter Relay shall be contested as a timed final, run in sections of no more than twelve.
 - (e) At the National Youth Athletics and National Junior Olympic Championship in the 8 and under, 9-10 and 11-12 divisions, the 1500 Meter Run shall be contested as timed finals, with no more than 18 participants per section. Competitors in the 13-14, 15-16 and 17-18 age groups shall run two rounds of the 1500 Meter Run with no more than 18 participants per heat in the first round and the best 12 times advancing to the final. At Association and Regional Championships, the Meet Referee has the discretion to allow more than 18 participants per heat or section.
 - (f) In events of 2000m or longer, timed finals shall be run with no more than 24 participants per section. The Meet Referee has the discretion to allow more than 24 participants per section.

- (g) At the National Junior Olympic Championship, the 100m, 200m, 400m, 80m Hurdles, 100m Hurdles and 110m Hurdles shall be contested in 3 rounds with the following requirements and procedures:
- i. Photo Finish (FAT) must be used.
 - ii. Twenty-four (24) shall advance to the semi-final round. This shall consist of the top 2 in each first-round heat and the remaining advancers determined by the next best times from the first round.
 - iii. A 3-heat semi-final round shall be contested with the top 2 from each semi-final heat and next 2 best times advancing to the final.
 - iv. Each group of advancers, in order by place ranked by time, followed in order by those advancing by time only shall determine the order of lane assignment for the semi-final and final rounds of competition.
- (h) At the National Junior Olympic Championship, the 200m Hurdles and 400m Hurdles, without regard to the number of athletes entered, shall be contested as two rounds with the top 8 times advancing to the final. The 4x100 Meter Relay and the 4x400 Meter Relay shall be contested as two rounds with the top 8 times advancing to the final.
- (i) In forming heats for events run partially or entirely in lanes where hand timing is used, the guidelines in Rule 166.1 through Rule 166.6 shall be followed. When Photo Finish (FAT) is used, in meets other than the National Youth Athletics or National Junior Olympic Championship, the following tables may be used:

FOR EIGHT LANES FAT ONLY					
Entries	Trial Heats	Qualifying to Semi-Final	Semi-Finals Heats	Qualifying to Final	Final
1 to 8	0	-	0	-	1 to 8
9 to 16	0	-	2	3 + next 2 best times	8
17 to 24	0	-	3	2 + next 2 best times	8
25 to 32	0	-	4	1 + next 4 best times	8
33 to 40	0	-	5	1 + next 3 best times	8
41 to 48	0	-	6	1 + next 2 best times	8
49 to 56	7	3 + next 3 best times	3	2 + next 2 best times	8
57 to 64	8	2 + next 8 best times	3	2 + next 2 best times	8
65 to 72	9	2 + next 6 best times	3	2 + next 2 best times	8
73 to 80	10	2 + next 4 best times	3	2 + next 2 best times	8
81 to 88	11	2 + next 2 best times	3	2 + next 2 best times	8

FOR NINE LANES FAT ONLY					
Entries	Trial Heats	Qualifying to Semi-Final	Semi-Finals Heats	Qualifying to Final	Final
1 to 9	0	-	0	-	1 to 9
10 to 18	0	-	2	3 + next 3 best times	9
19 to 27	0	-	3	2 + next 3 best times	9
28 to 36	0	-	4	1 + next 5 best times	9
37 to 45	0	-	5	1 + next 4 best times	9
46 to 54	0	-	6	1 + next 3 best times	9
55 to 63	0	-	7	1 + next 2 best times	9
64 to 72	8	3 + next 3 best times	3	2 + next 3 best times	9
73 to 81	9	3 + next 0 best times	3	2 + next 3 best times	9
82 to 90	10	2 + next 7 best times	3	2 + next 3 best times	
91 to 99	11	2 + next 5 best times	3	2 + next 3 best times	

- (j) The following procedure shall be used in forming heats:
- i. Weigh place first.
 - ii. Weigh time second.
 - iii. Seed each group of place winners as a unit by their times. Seed winners, then seed second places, etc. Work left to right, then right to left.
 - iv. If members from same club cause unequal distribution, adjust per Rule 303.1(a).
 - v. If all heats do not have an even number of competitors, draw by lot to an assigned heat.
 - vi. Heat order is drawn by lot.
- (k) The following procedure shall be used in assigning lanes:
- i. In the first round, lanes will be drawn by lot.
 - ii. For all other rounds, three draws will be made:
 - a. The first draw is for those preferred lanes as determined by the Games Committee, for a number equal to and not exceeding one-half the number of lanes used, for the highest ranked competitors in the race based on the ranked list for forming heats for the round.
 - b. The second draw is for those preferred lanes as determined by the Games Committee, for a number equal to and not exceeding one-half those competitors remaining after the first draw.

- c. The third draw is for the remaining competitors in the race and the remaining lanes.
 - (l) Where other than eight or nine lanes exist, modify procedures as appropriate. Where eight full lanes and a partial ninth lane exist, modify procedures for track events as appropriate.
 - (m) Always advance only eight athletes to the final round in both track and field events.
 2. Unless otherwise provided by the Games Committee:
 - (a) Whenever the number of entries or scratches reduces the number of actual participants in any heat or round of heats so as to eliminate the element of competition or creates a situation whereby the number of heats can be reduced, the Referee or designee shall redraw in the best interest of the competition.
 - (b) In the Association or Regional Championship, National Youth Outdoor and National Youth Indoor whenever the number of competitors reporting for an event makes heats, as required in this Rule, unnecessary, the event may be run as a final at the time in the program so scheduled for the heats.
 3. In the event that under paragraph 1(h), for those qualifying for succeeding rounds by method of best times, a tie causes more qualifiers than available lanes, the Referee shall determine if a run-off among those affected shall be conducted. If no run-off is conducted, those affected are eliminated.
 4. In the National Youth Athletics Championship, events of 100 meters to 400 meters inclusive, and relays up to and including the 4 x 400 meters, the fastest eight times from the preliminary round shall advance to the finals.
 5. At the Association-level meet, if the Games Committee determines that there are an insufficient number of seed times and/or a majority of the times submitted are believed to be inaccurate, the following procedure may be used in the interest of fair competition:
 - (a) For preliminary rounds only, both heat and lane assignments shall be drawn by lot. Advancement from the preliminary round shall be done by time without consideration of place.
 - (b) All other rounds, including timed finals, will adhere to the established rules for forming heats and advancement.
 6. **National Youth Indoor Championship** - For all running events from 55m through 400m, there will only be two rounds of competition. The eight fastest times shall advance from the first round to the final in all 15-16 and 17-18 age divisions.

RULE 304
NATIONAL CROSS COUNTRY PROGRAM

1. **General** - The Youth Athletics Division shall conduct cross country for all divisions in the USATF Youth Athletics program. Divisions shall be as set forth in Rule 300.1(b). National Championships may be conducted as directed by the Cross Country Subcommittee upon approval of the Youth Athletics Division

2. **Distances** - The 8 and under division shall run approximately 2km. The 9-10 and 11-12 divisions shall run approximately 3km. The 13-14 division shall run approximately 4km. The 15-16 and 17-18 divisions shall run approximately 5km.
3. **Course** -
 - (a) The course must be clearly marked, preferably with red flags to indicate a left turn, yellow flags to indicate a right turn and blue flags to indicate continuing straight ahead. All flags must be visible from a distance of 125m.
 - (b) There shall be no turn within 400m of the start. The running path shall be wide enough to allow several runners abreast during most, if not all, of the distance.
4. **Placing** - Transponders may be used to record the finish place of a runner in cross country. A bib transponder or two transponders per runner, one attached to each shoe or foot, must be used. With this condition, the finish place recorded by the chip system shall be the official order of finish provided that the finishing order is reviewed by a finish line imaging system to determine the order of finish for any questionable placing. The Referee has the authority to rule on matters of a timing irregularity or other irregularities.
5. **Scoring** - A team shall be composed of from five to a maximum of eight members. Team scoring shall be by place, in accordance with Rule 7. Team scoring is divided into five divisions for boys and five divisions for girls. The athlete's year of birth shall determine the division in which the athlete shall compete. With each succeeding year each division shall be adjusted as shown in the table below:

Cross Country Team Scoring Divisions

Division	2026	2027	2028	2029
8 and Under	2018+	2019+	2020+	2021+
9 – 10	2016-2017	2017-2018	2018-2019	2019-2020
11 – 12	2014-2015	2015-2016	2016-2017	2017-2018
13 – 14	2012-2013	2013-2014	2014-2015	2015-2016
15 – 18	2008-2011	2009-2012	2010-2013	2011-2014

6. **Uniform** - See Rule 251.
7. **Competition Numbers** - Competition numbers shall be worn chest-high in front.

**RULE 305
INDOOR CHAMPIONSHIP**

1. The Youth Regions are divided into 5 zones:
 Northeast Zone [regions covered 1 & 2].
 South Zone [regions covered 3, 4 & 6].
 Midwest Zone [regions covered 5, 7, & 8].
 West Zone [regions covered 10,11,13,14 & 15].
 Southwest Zone [regions covered 9 &12].
2. Indoor Track and field qualifying procedures –
 By December 31 of the year prior to the Indoor Championship, the Youth Athletics Executive Committee will distribute qualifying procedures for participation in the Youth Indoor Championship which may include participation in zone qualifying

meets, achievement of verified standards, or participation granted by waiver. The meet may also be open to all athletes achieving a qualifying standard.

RULE 306 JUNIOR OLYMPIC PROGRAM

1. General -

- (a) The Youth Athletics Division shall conduct the Junior Olympic athletics program of USATF. Junior Olympic meets shall be solely sanctioned and conducted under the aegis of USATF and its procedures. There shall be no dual sanctioning of Junior Olympic meets of USATF.
- (b) All of the competitions shall be conducted exclusively under the auspices of USATF. ("Exclusive USATF auspices" means that direction, publicity, promotion, rules, and awards must be entirely USATF.)
- (c) There will be competition for boys and girls in Association, Regional and National Championships in age divisions by year of birth. Events and age divisions are the same as for the regular USATF Youth Athletics National Championship program. An Association may host preliminary qualifying meets as long as eliminations are performed and athletes must advance and qualify for participation in the Association meet.
- (d) An Association is allocated, by agreement with other Associations in its Region, a certain number of athletes and relay teams from the Association level to the Regional level through the Association Championship.
- (e) The Youth Athletics Executive Committee may advance any athlete into the National Junior Olympic meet because of extraordinary circumstances. The request shall be made in writing to the Association Youth Chair, who shall then submit it to the Regional Coordinator, who shall then submit it to the Zonal Representative who shall then submit it to the Youth Athletics Executive Committee for review.
- (f) With the approval of the Association, athletes who miss their Association Championship because of extraordinary circumstances may be advanced to the Regional meet so long as such advancement does not displace an athlete who competed in the Association meet and does not exceed the Association's allocation to the Regional meet. If an Association has an athlete who meets an extraordinary circumstance and advancement would exceed their allocation, then the athlete may advance so long as all the Associations within the Region agree to the advancement.
- (g) Once an athlete begins participation in the Junior Olympic Program, throughout the entire Junior Olympic Series:
 - (i) Athletes who are unattached must remain unattached.
 - (ii) Athletes who represent a club shall not switch from one club to another.
 - (iii) An athlete may withdraw their club affiliation and compete unattached.

- (h) In exceptional circumstances, when necessary, the qualifying procedures listed in Rule 306.2 or 306.3 may be modified for the current year only as approved by the National Youth Executive Committee.

NOTE: Webster: *An exceptional circumstance is uncommon and/or out of the ordinary.*

- (i) Individual athletes who compete in their state high school or collegiate championship series may be advanced into their Regional if their Association meet date is in conflict with the athlete's school competition. Conflict means both meets are held within 48 hours of each other. A Team may also be advanced provided that all alternates listed on the declaration roster are in conflict with the school competition; resulting in not having a minimum of 5 athletes to participate. The individual athlete entry or the team roster must have been submitted by the registration deadline of the Association meet and no additional names can be added. The final decisions on the granting of this waiver shall be made by the Regional Coordinator.
- (j) The entry procedure and awards information will be distributed by the Youth Executive Committee in the meet entry/Technical Information document.

2. **Track and field qualifying procedures -**

- (a) An athlete can miss the Association Championship but not the Regional Championship, due to participation in a cultural (foreign exchange/educational) program. These exceptions must be worked out with the athlete's Regional coordinator before the meet takes place.
- (b) Athletes who compete in the U20 National Championship, United States Olympic Selection Competition, Youth Olympic Games Trials-Track & Field, Youth World Games, Youth Outdoor Championship in either the Heptathlon or Decathlon and achieve that event's standard, or additional sanctioned meets or events authorized by the National Youth Executive Committee may be entered in the National Junior Olympic meet without having to compete in the Association or Regional meet provided that they meet the Youth Athletics age limits. Acquisition of the waiver and completion of the entry to the National meet must be made prior to the Regional meet via the Regional coordinator and given to the National Youth Executive Committee.

NOTE: *Additional sanctioned meets or events authorized by the National Youth Executive Committee shall be determined and announced by December 31 in the year prior to the approved meet or event. The National Youth Executive Committee will distribute qualifying procedures for participation in the meet or event.*

- (c) Athletes from the Department of Defense Dependent Schools (DODDS) may be entered in the National Junior Olympic Championship without having to compete in a Regional meet, provided that they meet the Youth Athletics age requirements. They must enter through the Association hosting the National Junior Olympic Championship.
- (d) Track and field shall advance five individuals and five relay teams from each Regional to National. These shall be the top five finishers in each event. The Combined Events shall advance the top two placed individuals and any others who meet the performance standard at the Regional Championship. The performance standard for a Combined Event is the average of the 8th place in the

last three National Junior Olympic Championships. The number of qualifiers from Regional meets is fixed and no alternates may advance. The host Association shall qualify a like number.

- (e) An Association shall be allowed to advance alternate(s) from the Association to the Regional level, subject to the Association's filing deadline for the Regional meet.
- (f) Athletes who tie for fifth place at the Regional Track and Field meet shall be advanced to the national Junior Olympic Championship.
- (g) Advancement to the National Junior Olympic Track and Field Championship shall be by Association Championship to Regional Championship to National Junior Olympic Track and Field Championship, except a region, for a good cause and by a majority vote of the Associations in the region, and approval of the National Youth Executive Committee, may provide for advancement directly from the Association Championship to the National Championship. Qualifiers for the National Championship shall be as follows: 1) Region: The top 5 individuals by age division and the top five relay teams; 2) Association: The top 2 individuals by age division and the top one relay team.

3. **Cross country qualifying procedures –**

Where an Association holds preliminary meets, these will serve as qualifiers for its Championship; Association Championships are qualifiers for Regional Championships, and the Regionals are qualifiers for the Nationals.

- (a) It is suggested that 30 individuals and five teams advance from preliminary meets to Association meets and a like number of individuals and teams advance from Association meets to Regional meets. These numbers may be adjusted by the Association chair and Regional coordinator respectively for the purpose of accommodating their local situations.
- (b) Teams must represent current USATF member clubs; and athletes representing clubs must be registered members of said clubs prior to participation in their Association Championship.
- (c) All members of the same club listed on the team declaration roster at the Association finals are eligible to compete on the club's team (minimum of 5, maximum of 8) in the next round of Qualifications up to and including the National Championship as long as the team qualifies. In order to declare a team, a club must enter a minimum of 5 and a maximum of 8 athletes by the entry deadline. The composition of the team at each round can change if you submit a change form at the registration at packet pickup at least 2 hours prior to the race and any athlete changed must be listed on the declaration roster.
- (d) Advancement to the National Junior Olympic Cross Country Championship shall be by Association Championship to Regional Championship to National Junior Olympic Cross Country Championship, except a region, for a good cause and by a majority vote of the Associations in the region, and approval of the National Youth Executive Committee, may provide for advancement directly from the Association Championship to the National Championship. Qualifiers for the National Championship shall be as follows: 1) Region: The top 30 individuals by age division and the top five scoring teams; 2) Association: The top 15 individuals by age division and the top two scoring teams.

- (e) The number of qualifiers from Regional meets is fixed and no alternates may advance. Individuals finishing in the top 30 places and who are also members of the qualifying teams are not displaced so that additional finishers beyond thirtieth may not advance. Any team may advance if it has five or more individuals placing in the top 30 in the Regional meet. No team finishing beyond fifth place may advance based solely upon any of the first five teams' choosing not to advance.
4. Race Walk qualifying procedures –
- (a) The National Youth Executive Committee, with consultation from the National Race Walk Committee, shall create standards for athlete advancement to the National Junior Olympic Championship.
 - (b) Race Walk events shall advance the top two placed individuals and any other who meet the performance standard at the Regional Championship.

RULE 307
SPECIAL EVENTS AND PROGRAMS

1. **General -**
- (a) The National Youth Athletics Division may supplement existing programs with any approved event it deems in its best interest.
 - (b) The Youth Athletics Division shall determine the method and/or the number of qualifiers in special events and programs and list that information in a guide designed to serve such event or program.
2. **Pilot Programs or Competitions -**
- (a) Regional Youth Athletics indoor meets may be held and shall be awarded by those Association delegates represented in each Youth Athletics Region.
 - (b) The National Youth Athletics Division may adopt other pilot programs in Track and Field, Race Walking, Cross Country, or Long Distance Running.
3. **Youth Para Athletics Pilot Program**
- Within this pilot program, participating athletes will only advance to the Regional Meet. The qualifying procedures will be documented by the Youth Executive Committee and distributed. More detailed guidelines will be posted.
- NOTE:** *This program was established to ensure that athletes with disabilities have an opportunity to fully participate in USATF programs without their impairments posing barriers to competition.*
- (a) **General** – There will be competition for boys and girls in Association and Regional Championships in age divisions by year of birth. Events and age divisions are the same as for the regular USATF Youth Athletics National Program.
 - (b) Athletes will participate in Two (2) Divisions (Ambulatory and Wheelchair) and Four (4) events (100m, 200m, 400m, Shot Put).

- (c) All competitions shall be conducted exclusively under the rules and guidelines of USATF or the approved procedures provided the Youth Executive Committee for the Pilot program.
- (d) Para Athletes will be awarded the same USATF association and regional JO medals as their able-bodied and typical peers, within their respective gender, age-group and wheelchair or ambulatory divisions, unless otherwise stated.

4. Para Athletics Pilot Program

- (a) Para Athletes shall be classified (provisionally or nationally) and determined eligible to compete in Para Athletics events prior to participation in a USATF JO competition.

NOTE: *Classification plays a critical role in Para Track and Field competition by first assessing whether an athlete possesses an eligible impairment as determined by World Para Athletics. Athletes are then assigned to Sport Classes designed to minimize the impact of impairment, so that athletic performance is the determining factor in achieving success.*

Para Athletes are required to have a classification status to compete in a Youth Championship. Athletes needing classification, updates or changes must contact the USATF Para staff regarding classification requirements, complete all necessary documentation and participate in an in-person or video assessment prior to a USATF JO competition.

Classification Divisions for Track and jumps (T) and for field/throws (F)

Ambulatory Athletes with:

-Visual Impairments: T/F 11-13

-Intellectual Impairments T/F 20

-Coordination/neurological Impairments T/F 35-38

-Range of motion or power impairments/leg length difference/short stature T40-47 F40-46

-Leg deficiency using leg prosthesis T/F 61-64

-Severe coordination/neurological impairments using a Frame Runner T71-72 (will compete seated throws)

Wheelchair Athletes with:

-Coordination/neurological Impairments T/F 31-34

-Range of motion or power impairments/leg amputation T51-54 F51-57

- (b) World Para Athletics (WPA) Rules in conjunction with the applicable USATF Rules in Youth Athletics shall govern the events in this section. All other rules respective to the conduct of the JO competitions shall be governed by USATF Rules.
- (c) The program will consist of 4 events (100m, 200m, 400m and Shot Put) in 2 Divisions (Ambulatory and Wheelchair). There shall be no advancement from the Regional JOs to the National JOs at this time.
- (d) Para Athletes shall meet the same eligibility and JO entry requirements as their able-bodied and typical peers.

(e) Ambulatory and wheelchair racers shall compete in separate track event races. Ambulatory shall compete against other ambulatory athletes regardless of their individual classifications. Wheelchair shall compete against other wheelchair athletes regardless of classifications.

(f) Shot Put Specifications

8 & under	9 - 10	11 - 12	13 - 14	15 - 16	17 - 18
Ambulatory					
B-2k; G-2k	B-2k; G-2k	B-6lb.; G-6lb.	B-4k; G-6lb.	B-4k; G-6lb.	B-12lb.; G-4k
Wheelchair (seated)					
B-2k; G-2k	B-2k; G-2k	B-6lb.; G-2k	B-6lb.; G-2k	B-6lb.; G-6lb.	B-4k; G-6lb.

(g) The top (8) finishers in the Association JOs in the Ambulatory and Wheelchair Divisions, in every age division and event, shall advance to the Regional JO's.

(h) Para Athletes shall be awarded the same USATF Association and Regional JO Championship medals as their able-bodied and typical peers, within their respective genders, age-groups, events and Wheelchair or Ambulatory Divisions.

(i) Para Athletics Divisions:

- Boys Wheelchair Division (seated wheelchair racers and throwers)
- Boys Ambulatory Division (Para Athletes that stand/run)
- Girls Wheelchair Division (seated wheelchair racers and throwers)
- Girls Ambulatory Division (Para Athletes hat stand/run)

(j) Ambulatory Para Athletes

- (1) Ambulatory Para Athletes may compete in the same track event heats and shot put flights as their able-bodied and typical peers.
- (2) Para athletes, guide runners and assistants shall provide their own required competition adaptive equipment and accessories.
- (3) Guide runners are not required to receive an award.
- (4) Association or Regional JO meet management may award medals to guide-runners if they choose.
- (5) Field Assistants do not receive awards.

(k) Special Notes and Additional Regulations

(1) See USATF Rules, Appendix 3 – USATF Adaptations for Para Athletes.

(2) **USATF Rule 302.2(e)**

Ambulatory Division Para Athletes in the T11-13 and T20 classifications and in the 15-16- and 17-18-year-old age divisions, in accordance with WPA Rule 16, shall be required to use starting blocks and a crouch position for all events up to and including the 400 Meter Runs. The use of starting blocks and crouch stance by Ambulatory Division Para Athletes in all other classifications regardless of age division is optional and can be used in accordance with WPA Rule 16.

(3) In accordance with WPA Rule 16.4 Note (i) Para Athletes are permitted to request and receive assistance to set their starting blocks.

(4) **The Start**

In accordance with WPA Rule 17.7 Note (iii): As Para Athletes starting races in a standing position are more prone to over-balance, if such a

movement is considered to be accidental, the start should be regarded as “unsteady” and not declared a false start.

**SECTION II
MASTERS ATHLETICS**

**RULE 320
GENERAL RULES**

1. Article I, Sections I, III and IV, through Article V of the USATF Rules of Competition shall be followed unless otherwise provided in this Article VI, Section II (including Sections II-A and II-B).

2. There shall be the following age divisions for individual competition (five-year age groups):

AGES	MEN	WOMEN
25-29	M25	W25
30-34	M30	W30
35-39	M35	W35
40-44	M40	W40
45-49	M45	W45
50-54	M50	W50
55-59	M55	W55
60-64	M60	W60
65-69	M65	W65
70-74	M70	W70
75-79	M75	W75
80-84	M80	W80
85-89	M85	W85
90-94	M90	W90
95-99	M95	W95
100+	M100	W100

3. There shall be the following age divisions (five-year age groups) for relay events.

AGES	MEN	WOMEN
25+	M25	W25
30+	M30	W30
35+	M35	W35
40+	M40	W40
...
85+	M85	W85
90+	M90	W90

4. The age of a competitor on the first day of the meet determines the competitor's division for individual events.

5. The age division of a relay team is the age division of the youngest athlete on the entry form, as determined by Rule 320.4, and an athlete from that age division must actually compete in the relay.

6. The age division of an individual is not affected by the age division of a team or relay for which the individual competes.

7. The Meet or Race Director shall have the authority to request proof of age and/or a medical certificate attesting to the competitor's physical ability to compete. In addition, each competitor shall sign a "hold harmless" release.
8. A mixed event containing male and female participants is allowed. Masters records may be made in mixed age and/or mixed sex competitions.
9. Masters records for both relay and individual events may be recognized if at least two athletes (or teams), or one athlete in the 200m hurdles, are bona fide and have participated in the event in which the record purportedly was established.

**SECTION II-A
MASTERS TRACK AND FIELD AND RACEWALKING**

**RULE 330
GENERAL RULES**

1. Rules 330 through 333 apply to National, Regional, and Association Masters Championships. Meet Directors of non-championship events are also encouraged to follow these rules.
2. The Masters Track and Field Committee shall conduct and supervise a program for track and field and Race Walking for all athletes age 35 and over. The committee may conduct Championships for athletes aged 25 through 34.
3. In all National, Regional and Association Masters Championships, there must be a full complement of individual events, by five-year age divisions, for both men and women. There shall be a minimum of three medals per division in each event for USA Masters Eligible individuals. In the National and Regional Outdoor Championships, ribbons or equivalent are recommended for such eligible individuals in places 4-8. In all National Championships, duplicates for all awards shall be provided for guests (not eligible as above) who place 1-8. In Regional Championships, equivalent awards shall be provided for guests who place 1-8.
4. The term 'USA Masters Eligible' shall mean eligible to represent the United States in international competition according to WMA Championship Rules, and holding a current membership in USATF.
5. There are no competition uniform similarity requirements for a Masters relay team. Team identification shall be accomplished through the issuing of items such as letters or distinguishing numbers.

**RULE 331
MASTERS TRACK AND FIELD CHAMPIONSHIPS**

1. The standard Championship events are:
 - (a) National Indoor Track and Field
60 Meters, 200 Meters, 400 Meters, 800 Meters, 1500 Meters, 3000 Meters, 60 Meter Hurdles, 800 Meter Relay, 1600 Meter Relay, 3200 Meter Relay, 1500 Meter Walk, 3000 Meter Walk, High Jump, Pole Vault, Long Jump, Triple Jump, Shot Put, Weight Throw, Superweight Throw, Indoor Pentathlon
 - (b) National Outdoor Track and Field

100 Meters, 200 Meters, 400 Meters, 800 Meters, 1500 Meters, 5000 Meters, 10,000 Meters, 80/100/110 Meter Hurdles, 200/300/400 Meter Hurdles, 2000/3000 Meter Steeplechase, 5000 Meter Walk, 10k Walk, 400 Meter Relay, 1600 Meter Relay, 3200 Meter Relay, Shuttle Hurdle Relay, High Jump, Pole Vault, Long Jump, Triple Jump, Shot Put, Discus Throw, Javelin Throw, Hammer Throw, Weight Throw, Outdoor Pentathlon

NOTE: *For events in the Pentathlon, see rule 200*

(c) Regional and Association Indoor Track and Field
The same events as those conducted in the National Indoor Track and Field Championship. The Superweight Throw and Outdoor Pentathlon are optional. The 3000 Meter Race Walk is optional in Association Championships.

(d) Regional and Association Outdoor Track and Field
The following events shall be held:
100 Meters, 200 Meters, 400 Meters, 800 Meters, 1500 Meters, 5000 Meters, 80/100/110 Meter Hurdles, 200/300/400 Meter Hurdles, 5000 Meter Walk, 400 Meter Relay, 1600 Meter Relay, 3200 Meter Relay, High Jump, Pole Vault, Long Jump, Triple Jump, Shot Put, Discus Throw, Javelin Throw, Hammer Throw

The following events may be held:
10,000 Meters, 2000/3000 Meter Steeplechase, Shuttle Hurdle Relay, 10,000 Meter Walk, Weight Throw, Superweight Throw, Pentathlon, Heptathlon, and Decathlon

NOTE: *For Combined Events, see Rule 200*

(e) National Decathlon/Heptathlon. For events in the Combined Events see Rule 200.

(f) National Throws Championship
Throws Pentathlon - See Rule 201.
Ultraweight Pentathlon - See Rule 203.
Superweight Throw

(g) National Indoor Heptathlon for Men and Women.
The competition consists of seven events in the following order:
First day 60 Meters, Long Jump, Shot Put, High Jump
Second day: 60 Meter Hurdles, Pole Vault, 1000m(M)/ 800m(W)

2. There shall be club Championship at National Indoor and Outdoor Track and Field Championships. Scoring shall be in the following manner:

(a) Team scoring is restricted to individuals who are USA Masters Eligible, using the adjusted places after removing non-US citizens per Rule 330.3. See Rule 330.4.

(b) Scoring in individual events and relays shall be in each five-year age group and shall be eight (8) points for each first place, six (6) points for each second, four (4) points for third, three (3) points for fourth, two (2) points for fifth, and one (1) point for sixth. Team scoring is an aggregate of both men and women in all age groups who are team members. Awards shall be given to the top three clubs.

3. When it is not feasible to hold an event as a standard championship event, the Masters Track and Field Championship Games Committee may authorize the elimination of that event or the substitution of a comparable event. In addition, the Masters Track and Field Championship Games Committee may authorize the substitution of One Mile for 1500 Meters, either indoor or outdoor, and may authorize the substitution of the One Mile Race Walk for the 1500 Meter Race Walk indoors. In either case, the elimination or substitution must be reflected in the entry form and apply to all age groups.

RULE 332
COMPETITIVE RULES AND STANDARDS FOR
MASTERS TRACK AND FIELD

1. General

- (a) There shall be no Regional Championship entry restrictions to athletes who are USA Masters Eligible. However, only competitors with USATF membership in the Region shall be eligible to win Regional Championship places and awards and to score for any team. Regions may also invite guest competitors who cannot win Regional awards and cannot score.
- (b) Entries for any Championship event shall not be subject to prior achievement of a qualifying standard.
- (c) Where the number of entrants warrants it, finals may be conducted for multiple ages and/or mixed sexes simultaneously, subject to the following restrictions:
 - i. In events starting in lanes, all competitors in a given age division must start in contiguous lanes.
 - ii. In the throwing events, the groups that are consolidated groups should all use the same implement weight. For example, M60 and M65 may compete simultaneously in the shot put, since both groups use a 5kg shot, but M65 and M70 should not compete simultaneously since M70 uses a 4kg shot.
 - iii. In field events, each consolidated flight should contain no more than 12 competitors.
- (d) The 'honest participation' rule provided in Rule 142.4 and Rule 142.5 shall not be applicable to Masters Athletics.
- (e) Every Championship event, including Combined Event championships, will use the implement weights and dimensions, hurdle heights and spacings, and race lengths approved by WMA as of January 1 of the current year. A specification will be considered to have been approved by WMA when it has been published in the most recent WMA Rules of Competition. In the case of a new implement, this must include complete specifications. For those events included in a Combined Event, this must also include revised scoring tables. If WMA approves a specification change prior to January 1 with an effective date after January 1, the Masters Committee may adopt the new specification with an effective date of either (1) January 1 prior to the WMA effective date, (2) the same date as the WMA effective date, or (3) the January 1 after to the WMA effective date, and publish such date in these Rules.

- (f) At the National Track and Field Championship, the athletes advanced to the final in every track and field event shall consist of at least 2/3rds who are USA Masters Eligible. If adjustments are needed to meet this requirement, then the reduction in guest finalists shall be determined by performance with no consideration to place. Those USA Masters Eligible athletes that were advanced to the finals by place shall retain their position and the additional USA Masters Eligible athletes that will be added to the final shall be selected by performance with no consideration to place. The number of finalists shall not be increased to include additional non- USA Masters Eligible athlete finalists.

2. Track

- (a) In order to complete the National Track and Field Championship within the schedule, the Masters Track and Field Committee may adopt and publish a table for advancement to replace that of Rule 332.2(k).
- (b) When an individual or relay team, having qualified for a subsequent round, voluntarily withdraws for any reason, a single non-qualifier from the pool of the next two ranked non-qualifiers that have checked in with the clerk, shall advance to participate in that subsequent round. The provisions of Rule 332.2(a) shall not apply. The Referee shall redraw the lanes.
- (c) False starts are called on individuals, not on the field. For a first false start by a competitor, a yellow and black (diagonally halved) card shall be raised in front of the respective competitor(s), and when appropriately designed lane markers are being used, a corresponding indication should be made on the respective lane marker(s). For a second false start, the respective competitor(s) shall be disqualified.

NOTE: *In practice, when one or more athletes commit a false start, others are inclined to follow and, strictly speaking, any athlete who does so has also committed a false start. The Starter should warn or disqualify only such athlete or athletes who, in the Starter's opinion, was/were responsible for the false start. This may result in more than one athlete being warned or disqualified. If the recalled or aborted start is not due to any athlete (e.g. a false start caused by external noise), no warnings shall be given and a green card shall be shown to all the athletes. See Rule 162.17 Note.*

- (d) The general rule regarding the use of starting blocks and stance is waived. The use of blocks and stance is within the discretion of the competitor.
- (e) In events of 800 meters or longer and the long hurdles, timed finals shall be run. The number of participants per section shall be determined by the Masters Track and Field Games Committee. For seeding of timed finals, see Rule 166.5
- (f) Relay teams are defined as follows:
 - Club:** All members must be USA Masters Eligible in the Association in which the club is registered (or meet the residency exception of Regulation 4-B).
 - Non-Club:** Any team not meeting the club definition.

Club and Non-Club relay teams shall be separate divisions. At Association, Regional, and National Track and Field Championships, and all other meets, each relay team must meet one of the definitions above, or be a foreign national team as guest competitors in the Non-Club Division. A team meeting any of the above definitions may set a Masters record. Separate records shall be maintained in the

relays for (1) Club teams and (2) Non-Club teams. However, when the Club team record is the superior mark, it alone shall be recognized.

- (g) The Shuttle Hurdle Relay consists of four same-sex members. The Outdoor Short Hurdles use the same hurdle height, spacing, and distance as determined by the age of the youngest team member. After the race start, each team member must be in a set position when they start and shall start only after the incoming team member's torso passes their respective start line.
- (h) At the National Championship, athletes shall wear a chip or similarly worn electronic device in the track, Race Walking events and running events 3000 meters and longer for lap counting.
- (i) The tables which follow show WMA race specifications:
NOTE: *0.686m=27"; 0.762m=30"; 0.840m=33"; 0.914m=36"; 0.991m=39"*

HURDLE HEIGHTS AND SPACINGS

Division	Distance	Hurdles	Height	To First	Interval	to Finish
----------	----------	---------	--------	----------	----------	-----------

WOMEN'S INDOOR

25-39	60m	5	0.840m	13.00m	8.50m	13.00m
40-49	60m	5	0.762m	12.00m	8.00m	16.00m
50-59	60m	5	0.762m	12.00m	7.00m	20.00m
60-69	60m	5	0.686m	12.00m	7.00m	20.00m
70 +	60m	5	0.686m	11.00m	6.00m	25.00m

MEN'S INDOOR

25-49	60m	5	0.991m	13.72m	9.14m	9.72m
50-59	60m	5	0.914m	13.00m	8.50m	13.00m
60-69	60m	5	0.840m	12.00m	8.00m	16.00m
70-79	60m	5	0.762m	12.00m	7.00m	20.00m
80 +	60m	5	0.686m	11.00m	6.00m	25.00m

WOMEN'S OUTDOOR SHORT

25-39	100m	10	0.840m	13.00m	8.50m	10.50m
40-49	80m	8	0.762m	12.00m	8.00m	12.00m
50-59	80m	8	0.762m	12.00m	7.00m	19.00m
60-69	80m	8	0.686m	12.00m	7.00m	19.00m
70 +	80m	8	0.686m	11.00m	6.00m	27.00m

MEN'S OUTDOOR SHORT

25-49	110m	10	0.991m	13.72m	9.14m	14.02m
50-59	100m	10	0.914m	13.00m	8.50m	10.50m
60-69	100m	10	0.840m	12.00m	8.00m	16.00m
70-79	80m	8	0.762m	12.00m	7.00m	19.00m
80 +	80m	8	0.686m	11.00m	6.00m	27.00m

WOMEN'S OUTDOOR LONG

25-49	400m	10	0.762m	45m	35m	40m
50-59	300m*	7	0.762m	50m	35m	40m
60-69	300m*	7	0.686m	50m	35m	40m
70 +	200m*	5	0.686m	20m	35m	40m

MEN'S OUTDOOR LONG

25-49	400m	10	0.914m	45m	35m	40m
50-59	400m	10	0.840m	45m	35m	40m
60-69	300m*	7	0.762m	50m	35m	40m
70-79	300m*	7	0.686m	50m	35m	40m
80 +	200m	5	0.686m	20m	35m	40m

Division Distance Height

STEEPLECHASE – see Rule 169

Women – All	2000m	0.762m	
Men - 25-59	3000m	0.914m	<u>or 0.838m</u>
Men - 60 +	2000m	0.762m	

NOTE 1: *The 3000m height of (33”) 0.838m or (36”) 0.914m is acceptable for competitions and records.*

NOTE 2: *To set a new record in the Men 35-59 3000m, time for the event must be faster than the existing record time for either barrier height. There shall be only one record for this event.*

**The locations for the hurdles in the 300m event are the same as the last seven hurdles of the 400m event. They are not same as the high school 300m hurdle race, which uses eight hurdles. The locations for the hurdles in the 200m event are the same as the last five hurdles of the 400m event.*

(j) Championship advancement procedures:

FOR OUTDOOR – 100, 200, 400, Short Hurdles					
Declared Entries	Trial Heats	Qualifying to Semi-Final	Semi-Finals Heats	Qualifying to Final	Final
1 to 8	0	-	0	-	1 to 8
9 to 16	0	-	2	2 + next 4 best times	8
17 to 24	0	-	3	2 + next 2 best times	8
25 to 32	0	-	4	1 + next 4 best times	8
33 to 40	0	-	5	1 + next 3 best times	8
41 to 48	0	-	6	1 + next 2 best times	8
49 to 72	0	-	7 / 8 / 9	0 + next 8 best times	8

FOR EIGHT LANES INDOOR – 60, 60 Hurdles					
Declared Entries	Trial Heats	Qualifying to Semi-Final	Semi-Finals Heats	Qualifying to Final	Final
1 to 8	0	-	0	-	1 to 8
9 to 16	0	-	2	2 + next 4 best times	8

17 to 24	0	-	3	2 + next 2 best times	8
25 to 32	0	-	4	1 + next 4 best times	8
33 to 40	0	-	5	1 + next 3 best times	8
41 to 48	0	-	6	1 + next 2 best times	8
49 to 56	0	-	7 / 8	0 + next 8 best times	8

FOR SIX LANES INDOOR – 60, 60 Hurdles, 200					
Declared Entries	Trial Heats	Qualifying to Semi-Final	Semi-Finals Heats	Qualifying to Final	Final
1 to 6	0	-	0	-	1 to 6
7 to 12	0	-	2	2 + next 2 best times	6
13 to 18	0	-	3	1 + next 3 best times	6
19 to 24	0	-	4	1 + next 2 best times	6
25 to 48	0	-	5 / 6 / 7 / 8	0 + next 6 best times	6

Outdoor – Events 800m and longer and the long hurdles: Finals on time.

Indoor – Events 400m and longer: Finals on time.

3. Field

- (a) The procedures set forth in Rule 180.9 shall be applied when there are more than 12 competitors in field events. The Masters Track and Field Games Committee for the Masters National Track and Field Championship may increase the number of competitors in each flight in order to maintain and finish within the competition schedule.
- (b) When a vertical jumps group of competitors is sufficiently large and/or diverse in ability, the Jumps Referee shall have the option of dividing the group into two simultaneous competitions using similar facilities and conditions. The same progression of increments shall be used. Simultaneous height changes are not required.
- (c) In the vertical jumps, a competitor who has not taken an initial trial in at least one (1) hour from the first trial of the competition, shall be allowed, under the direction of the event official, to use the runway and landing areas without the crossbar to warm-up with one attempt within one minute. Such warm-up shall occur at the change of the bar to the height the competitor enters the competition.
- (d) In the High Jump and Pole Vault, Masters competitors are allowed to touch the landing area before clearing the bar, but may not use the landing area to any advantage as determined by the Field Judge.

NOTE: *It is not required that the pole be released by the athlete.*

- (e) The total number of athletes remaining in the competition for rule 180.12(c) shall be determined by the total number of athletes remaining in the flight, not the total number of competitors remaining in an individual age/sex division.
- (f) Rule 181.7(a) and Rule 181.7(b) shall apply for all athletes in a flight, as a whole, regardless of the flight's age/sex division composition.
- (g) Rule 181.7(c) shall only apply to an athlete who has won their respective age/sex division in a flight and is attempting a U.S National or WMA Record. In such a case, the time allowed for the trial shall be that allowed as if only one athlete remains in the competition and the attempted record height shall be inserted into the predetermined height progression, if necessary, for that athlete only.
- (h) Privately owned implements shall be exempt from the loss of identity provision in Rule 187.10.
- (i) The WMA weights for throwing implements, including the Superweight, are shown in the following table:

WMA IMPLEMENTS

Women

Ages	Shot	Discus	Hammer	Javelin	Weight
25-49	4kg	1kg	4kg	600g	9.08kg (20#)
50-59	3kg	1kg	3kg	500g	7.26kg (16#)
60-74	3kg	1kg	3kg	500g	5.45kg (12#)
75 +	2kg	0.75kg	2kg	400g	4 kg (8.8#)

Men

25-49	7.26kg (16#)	2kg	7.26kg (16#)	800g	15.88kg (35#)
50-59	6kg	1.5kg	6kg	700g	11.34kg (25#)
60-69	5kg	1kg	5kg	600g	9.08kg (20#)
70-79	4kg	1kg	4kg	500g	7.26kg (16#)
80 +	3kg	1kg	3kg	400g	5.45kg (12#)

SUPERWEIGHT

Women

Ages	Weight	Men	Weight
25-49	15.88kg (35#)	30-59	25.40kg (56#)
50-59	11.34kg (25#)	60-69	20.00kg (44#)
60-74	9.08kg (20#)	70-79	15.88kg (35#)
75 +	7.26kg (16#)	80 +	11.34kg (25#)

- (j) WMA weights and dimensions are in the individual implement tables. See Rules 188.4, 189.3, 191.9, 193.6 and 195.9 NOTE 2.
- (k) In the Long Jump and Triple Jump, more than one take-off board may be used, even within a single age division. All take-off boards shall measure 0.20m in width. In the long jump, one or two take-off boards may be used, one of which shall be 0.5m or 1m from the nearer end of the landing area. In the triple jump,
 (i) two or more take-off boards may be used,

- (ii) when more than one take-off board is used, each take-off board shall be placed in full meters apart from the take-off line closest to the nearer end of the landing area.

The take-off boards may consist of material other than wood. Each jumper shall declare prior to each jump which board he or she will use. Plasticine is not required.

4. **Combined Events**

- (a) Combined Event scoring will use current scoring procedures in WMA Competition Rules Appendix B.

NOTE: *Use an age factor of 1.0 for each event for ages 25 to 34.*

- (b) The winner of any Combined Event shall be the competitor who scores the highest total number of points. If two or more athletes achieve an equal number of points for any place in the competition, the procedure to resolve the tie is the following in order until each method is exhausted:

- i. the athlete who, in the greater number of events, has received more points than the other athlete(s) concerned shall be awarded the higher place.

- ii. If the athletes are equal following the application of Rule 332.4(b) i., the athlete who has the highest number of points in any one event shall be awarded the higher place.

- iii. For any athletes still equal following the application of Rule 332.4(b)ii., the athlete who has the highest number of points in a second event, or continuing event comparisons if needed. shall be awarded the higher place.

- iv. If the athletes are still equal following the application of Rule 332.4(b)iii., it shall be determined to be a tie.

NOTE: *Rule 332.4(b).i shall not be applied when more than two competitors are tied.*

RULE 333

MASTERS RACE WALKING CHAMPIONSHIPS

1. **Outdoors**

Masters Race Walking Championships may be held at any distance of 1500 meters or longer and may be conducted with the Open Championships. A 5000 Meter Walk is a Championship event in the National Outdoor Track and Field Championship, held in addition to the 5000 Meter Walk Championship conducted in accordance with the list in Rule 25.1(a).

2. **Indoors**

The 3000 Meter Walk is an event in the National Indoor Track and Field Championship.

For record requirements, See Rule 266.

For Championship meet requirements, See Rules 25.2 through 25.4.

3. **Team Championships**

In Race Walking events, except those conducted as part of the Masters Track and Field Championship, team championships shall be conducted in 10-year age divisions for men and women. For all divisions, the number of entries for each team shall be unlimited, the number of declared team members shall be up to five (5), and three (3) individuals shall score. Team Championships at the Association level are optional.

**SECTION II-B
MASTERS LONG DISTANCE RUNNING**

**RULE 340
GENERAL RULES**

1. The Masters Long Distance Running Committee shall conduct and supervise a program for long distance running for all athletes over the age of 40.
2. All Long Distance running races including cross country with Masters Athletes are encouraged to follow the rules for Masters Long Distance Running Championships whenever possible.
3. A competitor may be asked to provide his/her legal date of birth when he/she registers for a USATF sanctioned competition. In the case that a competitor claims a record or receives prize money for any age-dependent event, he/she may be required to present proof of age. The form of proof unless otherwise specified, shall be a certified copy of a birth certificate or a passport. Once an athlete has declared a birth date for U.S. competition, the athlete may not subsequently change that birth date to gain an advantage in a different age group. In the event that an actual birth date is unascertainable for a foreign competitor, he/she shall contact the embassy in the US of the competitor's country of citizenship or birth and determine the best method for age verification. This method may include issuance of a new passport, certified birth certificate or court order verifying the age of the individual. The obligation to obtain age verification documentation is on the athlete.

**RULE 341
MASTERS LONG DISTANCE CHAMPIONSHIPS**

1. Team scoring for cross country shall be as follows:
 - (a) M40+ and M50+ five (5) individuals shall score with a maximum of nine (9) individuals declared per team;
 - (b) M60+ and above, and all women's teams three (3) individuals shall score with a maximum of five (5) individuals declared per team.

Team scoring for road racing Championships shall be as follows:

All teams, men and women, in all 10-year age divisions, three (3) individuals shall score with a maximum of five (5) individuals declared per team.

2. Masters Championships may be held at any distance of one mile or longer off the track (i.e., road, trail, mountain or cross country), and at any distance longer than 10,000 meters on the track.
3. Championships must be sanctioned by USATF, and road courses should be certified prior to bid submittal and must be USATF-certified prior to the running of the event.
4. The age of the competitor on the day of the start of the race determines the age division. A runner may compete in a younger division as a team member. If he/she runs on a younger team, the runner may still compete as an individual in his/her true age division if both divisions are run simultaneously. Only a birth certificate or a U.S. passport will be acceptable as proof of age.

5. Competitors in a Championship must be current members of USATF. Only U.S. citizens shall be allowed to win USATF medals and other Championship awards or to score on a team.
6. In Masters LDR championships, to be eligible for individual or team scoring or awards, a bib, supplied by the games committee which identifies gender and age group, shall be worn on the back.
7. If a Masters Championship is part of a larger event, Championship competitors shall be eligible for awards in their divisions or age groups in the non-championship event.
8. Teams shall represent current member clubs of USATF, verified through the national office. USATF Association, Regional, or National "all-star" teams are not eligible to compete in Masters Long Distance Running Team competition. Team members shall be affiliated with the club they are representing on their USATF membership record prior to entering the competition. One athlete per team (i.e., Club M50+ team) who is a non-resident member of an Association is eligible to compete for a team in that Association.
9. For team scoring, see Rule 7. Unless the Championship event has issued items such as letters or distinguishing numbers to identify teams, see Rule 251.3 for apparel requirements in team-scored Championships
10. An event chosen as a Masters Long Distance Running Championship shall use a Transponder Timing system as the primary timing and recording system, using 'Net Timing', 'Gun Timing' or a combination of both as determined by the Games Committee. If 'net timing' is used then Rule 165.15 shall apply. In addition, an authorized imaging system placed on the finish line shall be used to validate places, times and possible records. Non-championship events may use "select timing" to validate times and records. For Transponder Timing, FAT camera, video timing requirements and timing practices, see Rule 165. For records, see Rule 265.1
11. Regulation USATF medals shall be awarded to first, second, and third place individuals in each age division and to the declared members of the first, second and third place teams in each team division. Regulation USATF medals may also be awarded to the overall first, second, and third place age-graded individuals for each gender. Championship patches may be awarded to the winners of each age division and to the declared members of the winning team in each team division.
12. In Masters Long Distance Running including Masters Cross Country, an athlete who is an athlete member of one club according to their USATF online membership profile at the date and time of closing of online entries for Masters LDR and Master Cross Country Championships may not subsequently change membership to another club prior to the Championship or be eligible to represent or score points for the club to which he/she seeks to change membership. If the athlete does not desire to compete for their original club, they may compete unattached, representing no club. Changing club affiliation prior to entry deadlines is the responsibility of the athlete.



USATF[™]

Appendix 1
ILLUSTRATIONS

FIGURE 1 - HURDLE

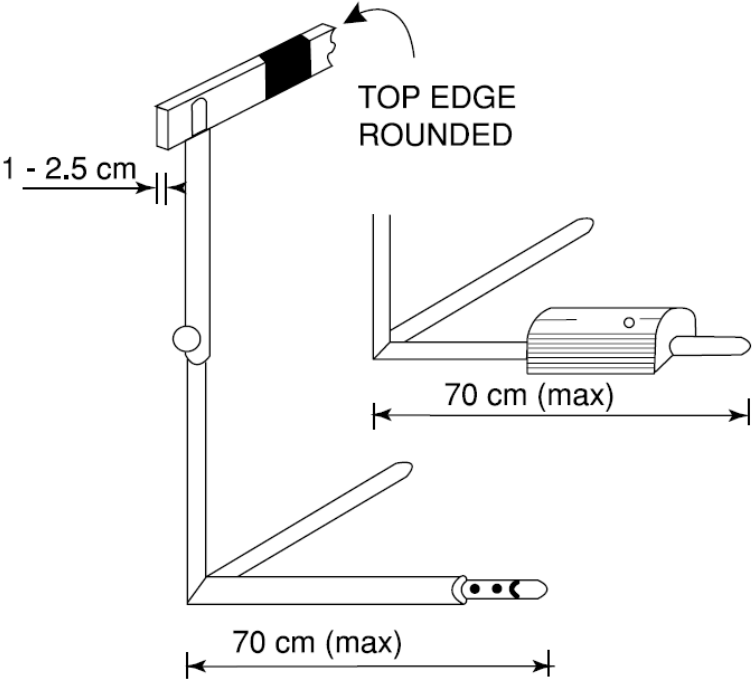
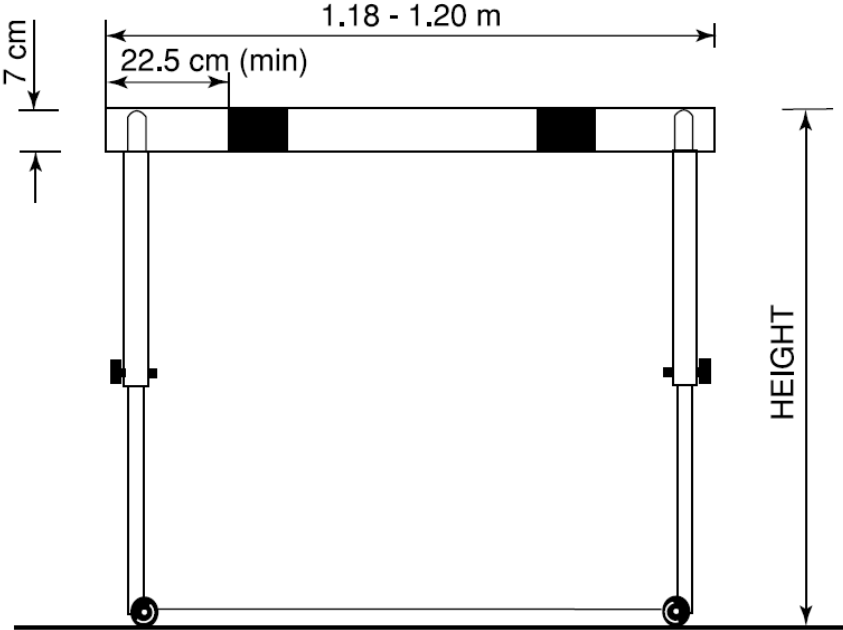
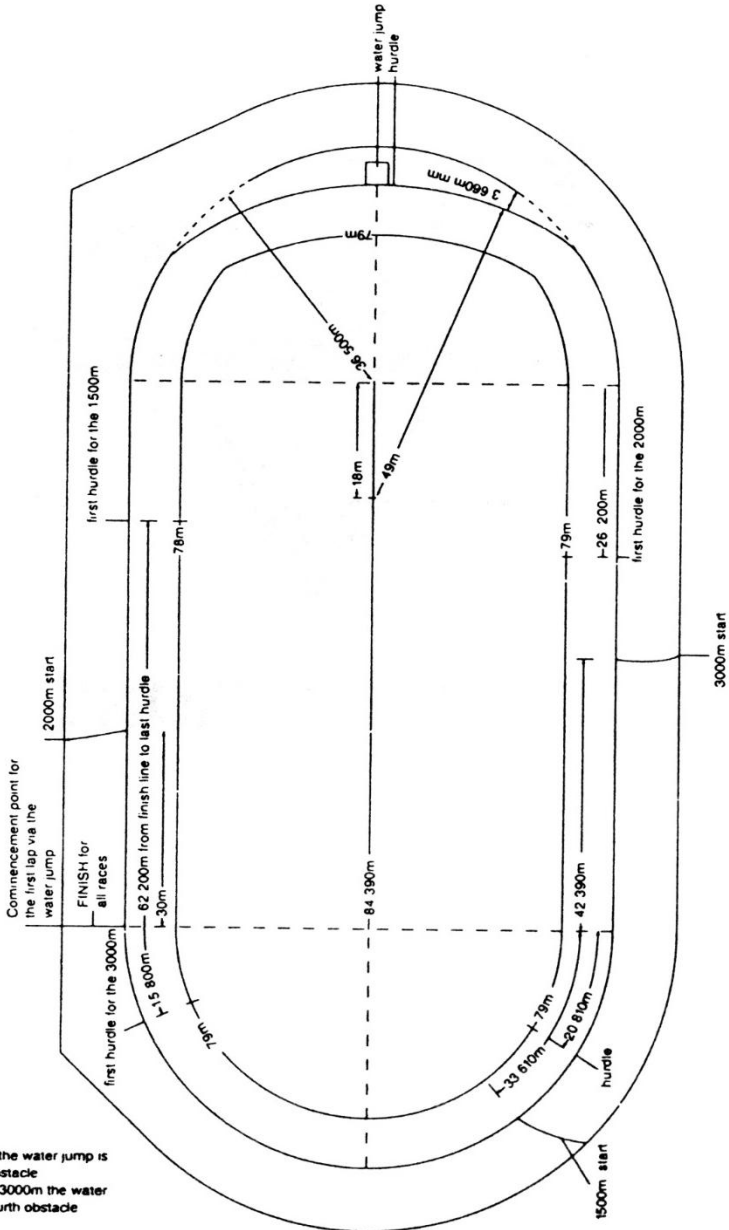

FIGURE 2



NOTE: This diagram is an illustration of the approximate location of start lines and barrier locations based on an inside water jump. The specific locations will change depending on the given track layout, particularly for an outside water jump.

FIGURE 3 – STEEPLECHASE BARRIER

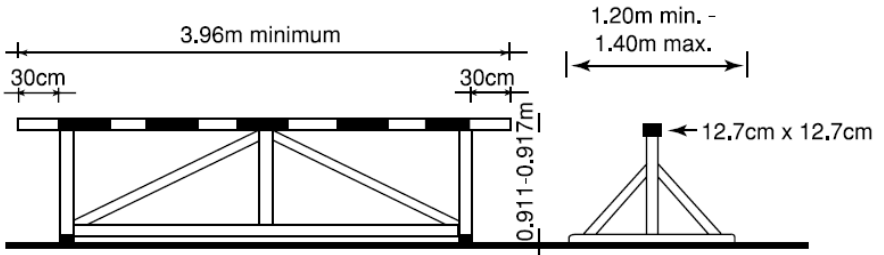

FIGURE 4 – WATER JUMP

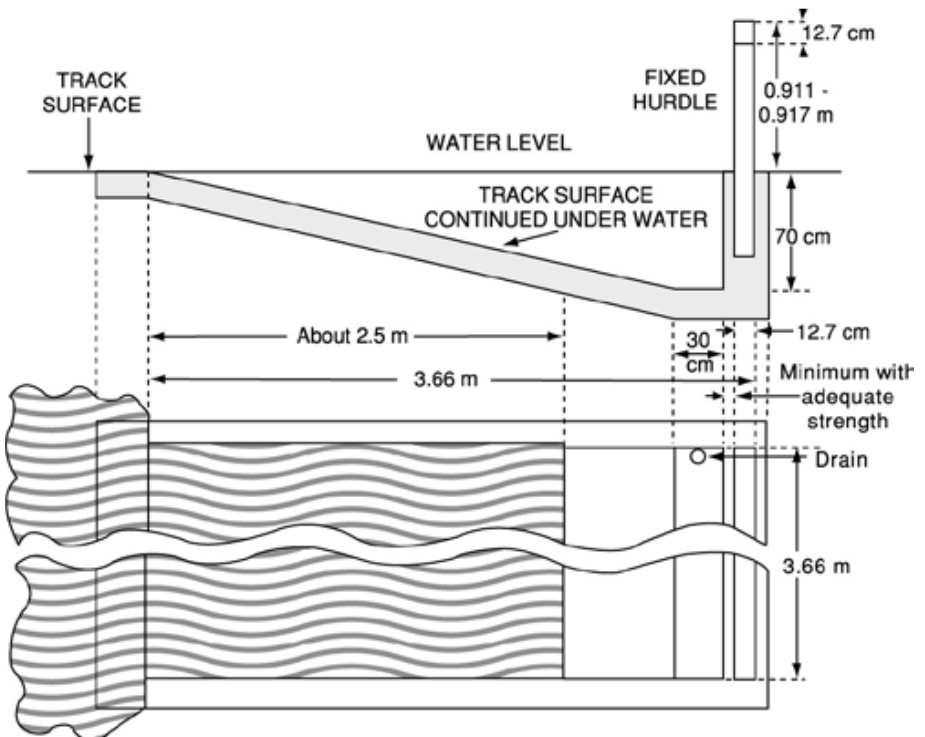
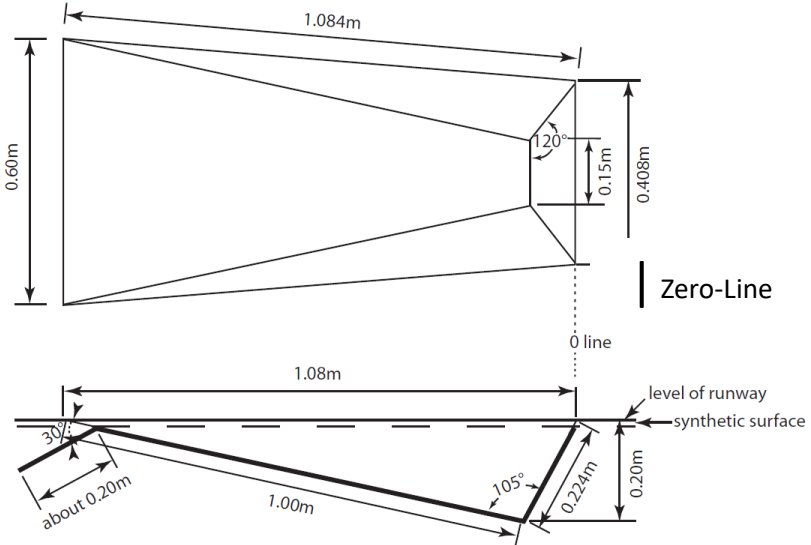

FIGURE 5 – POLE VAULT BOX AND LANDING AREA



tolerances: $\pm 0.01\text{m}$, $-0^\circ/+1^\circ$

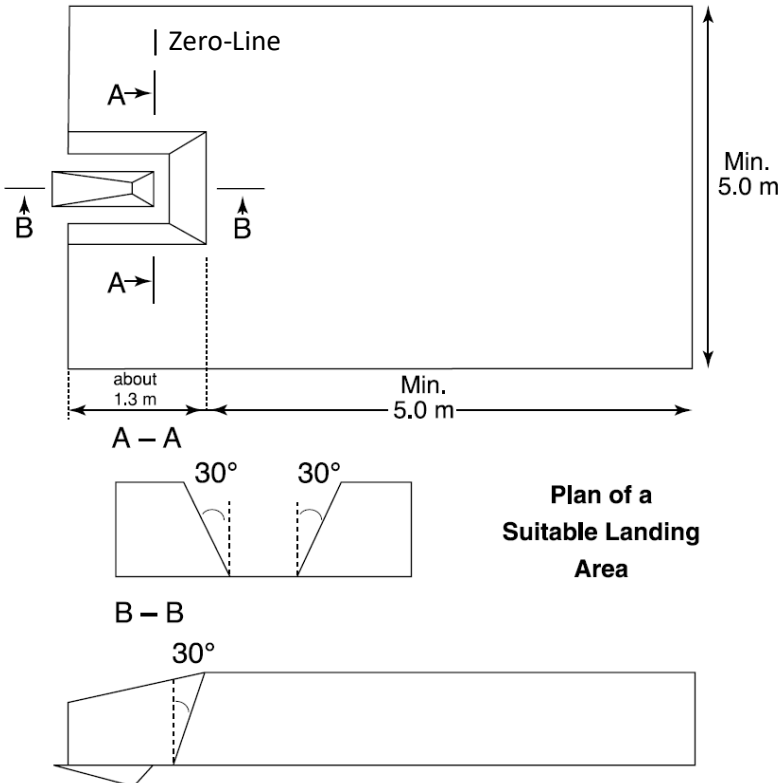

FIGURE 6 – TAKE-OFF BOARD AND PLASTICINE BOARD

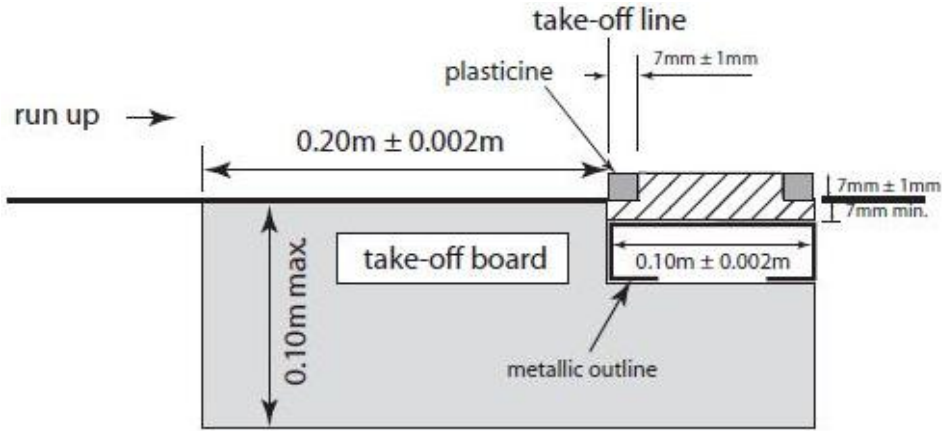

FIGURE 7 – END VIEW OF CROSSBAR

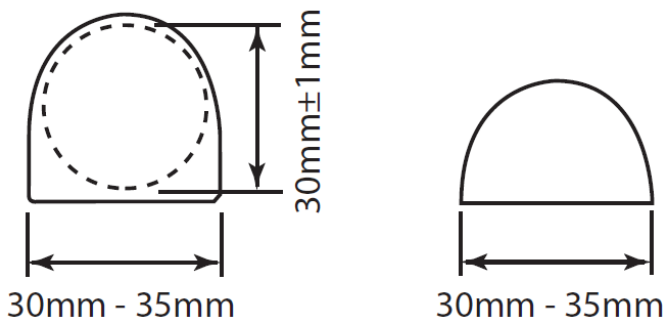

FIGURE 8 – LAYOUT OF CONCENTRIC CIRCLES FOR DISCUS AND HAMMER

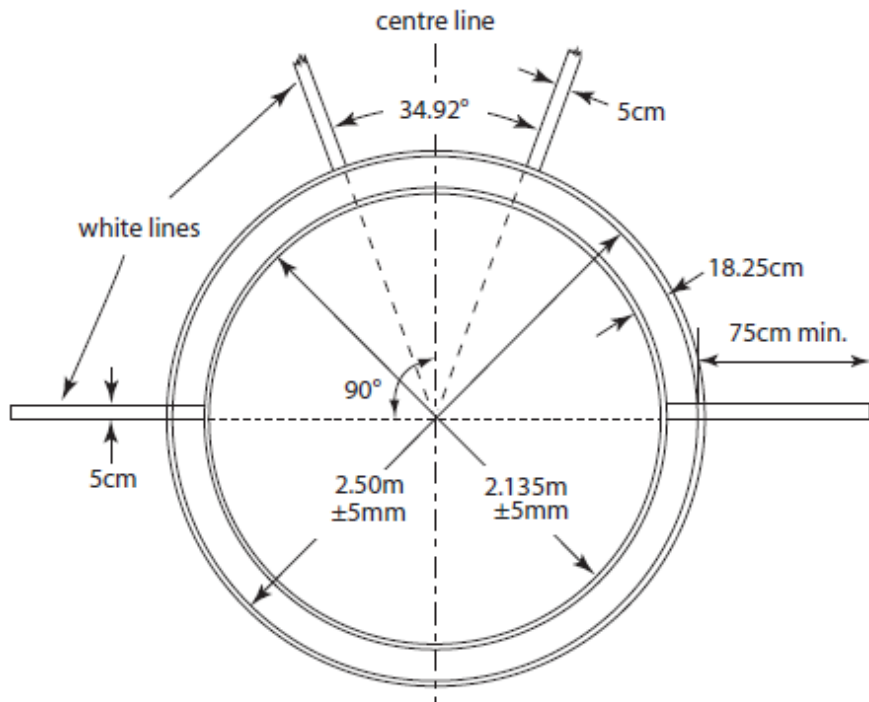

FIGURE 9 – LAYOUT OF SHOT STOP-BOARD

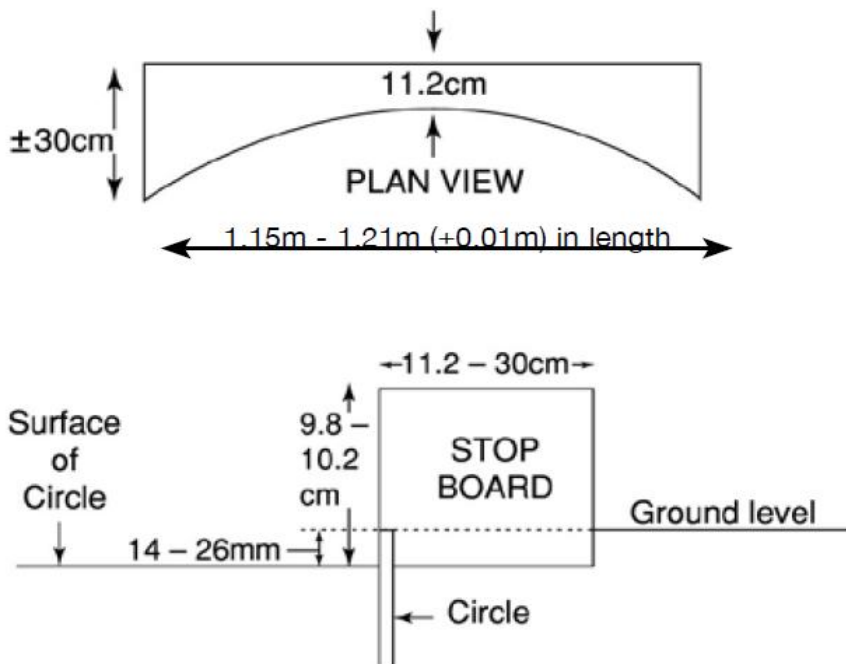

FIGURE 10 – DISCUS

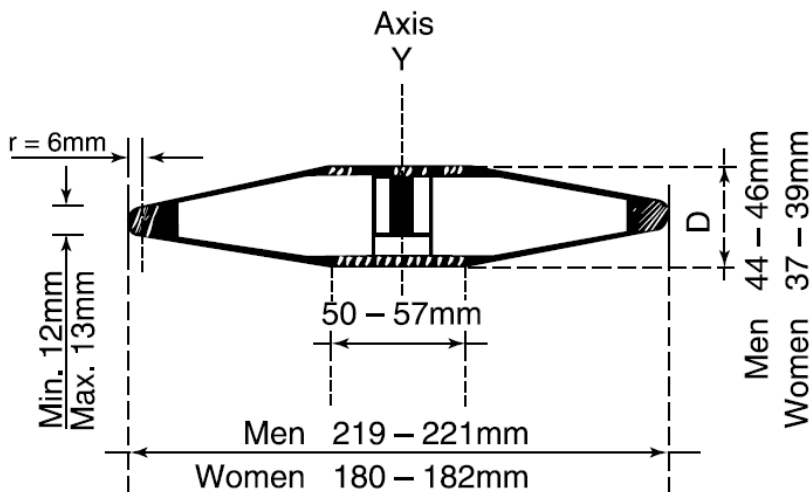
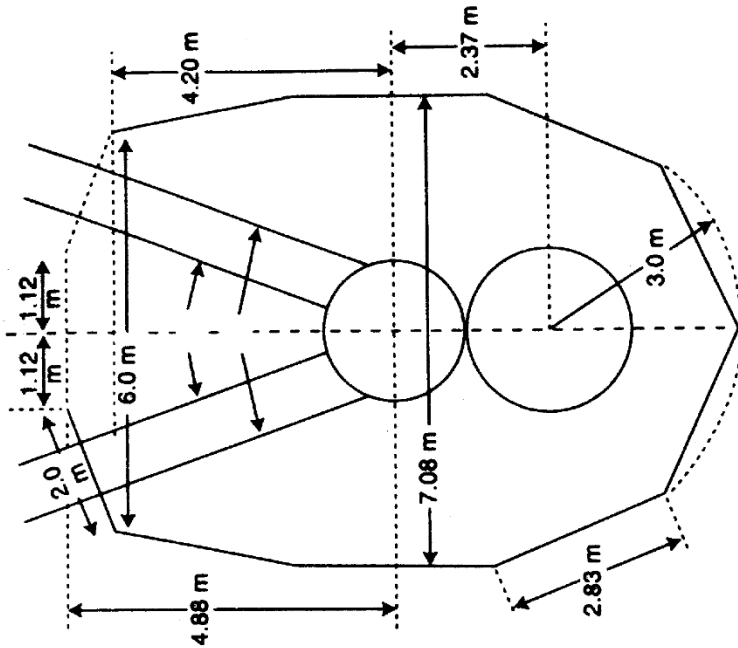
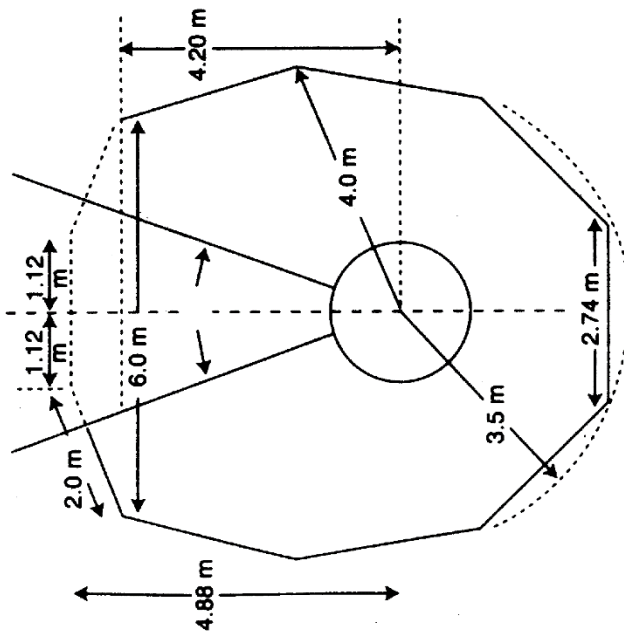

FIGURE 13 – ALTERNATE LAYOUTS USING PRE-2004 CAGES



Cage for Hammer and Disc



Cage for Hammer Only

FIGURE 14 – HAMMER HANDLE

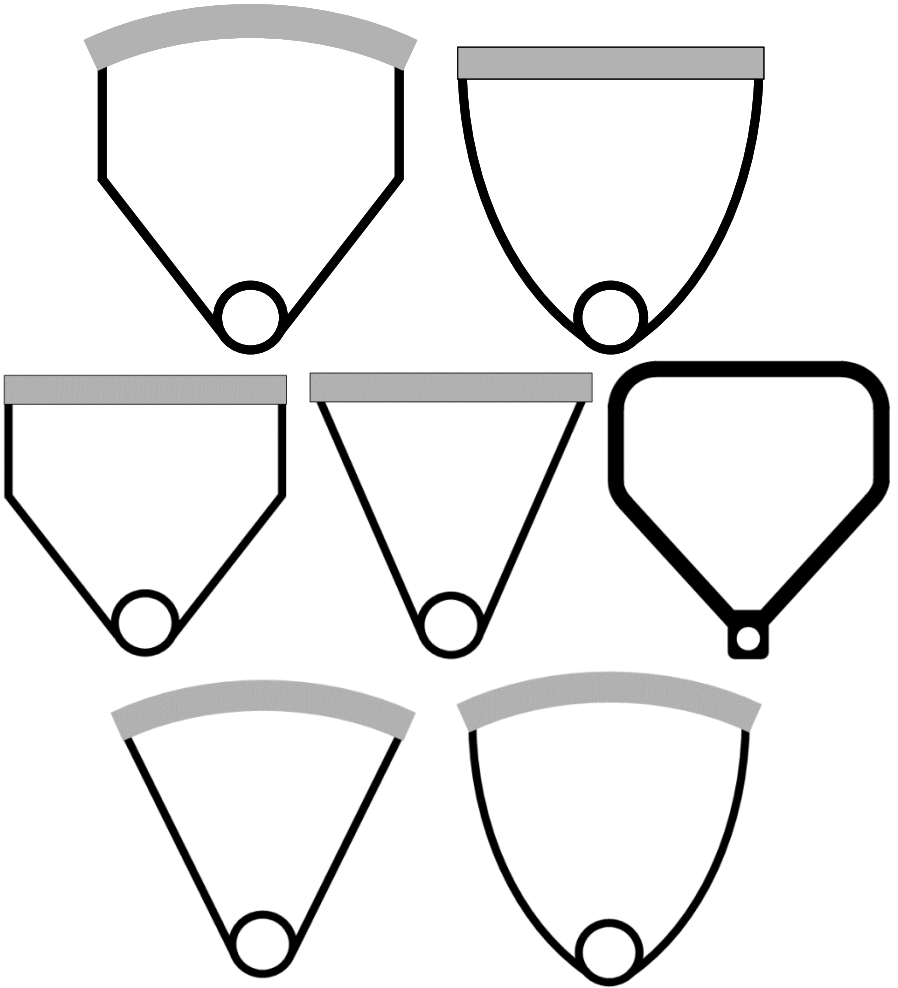

NOTE: *The hammer handle may have any configuration that meets the specifications (Rule 191.7). This includes all configurations in this figure and variants thereof.*

FIGURE 15 – WEIGHT HANDLE

HANDLE FOR WEIGHT WITH FILLED HEAD

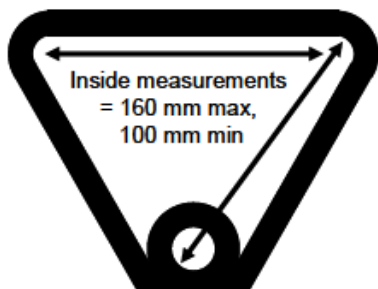

Handle with internal brace

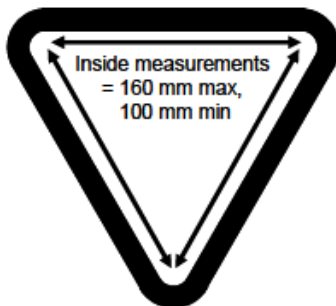

Handle without internal brace
(all sides must be equal)

HANDLE FOR WEIGHT WITH ALL-METAL HEAD

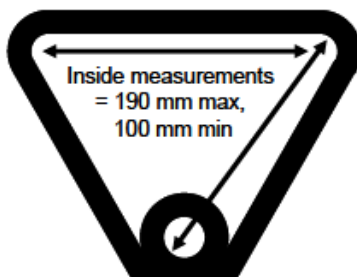

Handle with internal brace

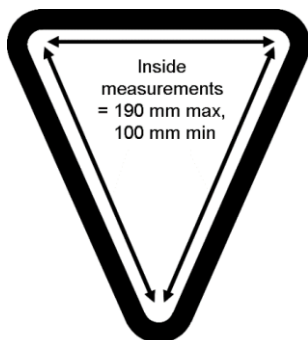

Handle without internal brace

FIGURE 16 – MINI JAVELIN

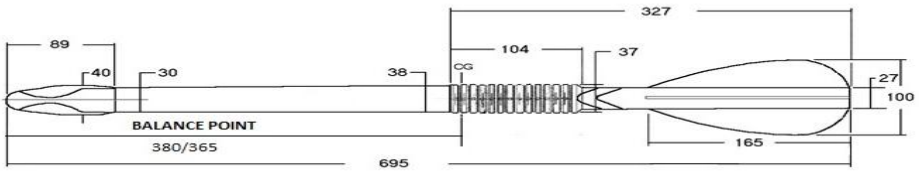

FIGURE 17 – AERO JAVELIN

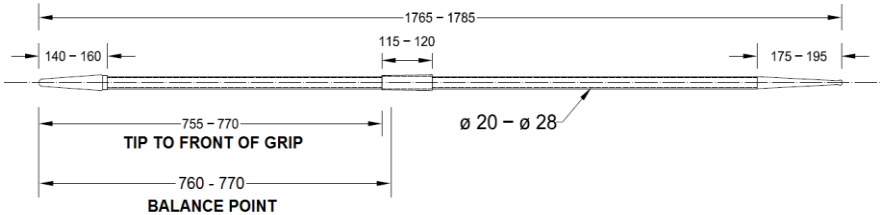

FIGURE 18 – Field Event Time Limits (Alternative)

TIME IN MINUTES FOR INITIATING A FIELD EVENT TRIAL						
		Total # of athletes remaining in the competition at the start of a bar height or round. ^a				
EVENT	Type	More than 3 ^b	2 or 3	1	Consecutive Trials ^c	
High Jump	Individual	1	1.5	3 ^d	2	
	Combined	1	1.5	2	2	
Pole Vault	Individual	1	2	5 ^d	3	
	Combined	1	2	3	3	
Throws & Horizontals	All	1	1	1	2	
NOTES:						
a. Athletes remaining in competition include those who could be involved in a jump-off for 1 st place.						
b. This also applies to an athlete's very first trial in the competition.						
c. Consecutive may occur either within or between bar heights.						
d. When only one competitor, who has won the competition is attempting a World Record or other record directly relevant to the competition, the time limit indicated shall be increased by one minute.						

APPENDIX 2 RECORD APPLICATION FORM

This form shall be used for American and World records. See instructions on reverse.
It may be used for collegiate or other jurisdictional performances.

APPLICATION FOR RECORD



- International Association of Athletic Federations (*World Records*)
- USA Track & Field (*American Records, World Record Approval*)
Address: 132 East Washington St., Indianapolis, IN 46204-3723
- NCAA NAIA NJCAA Other _____

To THE RECORD COMMITTEE:

Application is hereby made for a record, in support of which, the following information is submitted:

1. Description of Record: World American Association Championship Collegiate
 Junior* Age Group* _____ Masters* _____
**Application must be accompanied by copy of birth certificate or other proof of age.*

Event _____ Men / Women Indoor / Outdoor

Competition Name _____ Date _____ Time of Day _____

Location: Arena _____

Town _____ State _____ Country USA

Record Claimed (time, distance, height or points achieved): _____

Printed Full Name of Competitor, Club and Country: (Print first name first. List relay members in their running order.)

2. **Starter's Certificate:** I certify I was the Starter and that the start of this race was in accordance with IAAF or applicable Rules. For World Records, excluding World Junior Records, I certify the satisfactory use of an approved false start detection system in all races which require the use of blocks.

Printed Name _____ Signature _____ USATF Cert # _____

Start Coordinator Printed Name _____ Signature _____ USATF Cert # _____

3. **Automatic Timing Certificate:** A fully automatic timing device was used; manufactured by: _____
As Chief Photo Finish Judge, I certify the correct positioning, proper testing and a satisfactory zero control test for the equipment.

As Chief Photo Finish Judge, I certify the time recorded was _____, and this was the official time.

Printed Name _____ Signature _____ USATF Cert # _____

4. **Hand Timing Certificate:** I, the undersigned official timekeeper for this event, do certify that the time set opposite my signature was the exact time recorded by my watch, and that the watch used by me has been certified and approved by my National Association.

Time _____ Printed Name _____ Signature _____ USATF Cert # _____

Time _____ Printed Name _____ Signature _____ USATF Cert # _____

Time _____ Printed Name _____ Signature _____ USATF Cert # _____

I, as Chief Timekeeper or Referee, confirm the above Timekeepers exhibited their watches to me and that the times were as stated.

Printed Name _____ Signature _____ USATF Cert # _____

5. **Wind Gauge Certificate:** I, as the Wind Gauge Operator, certify the force of the following wind as: _____ m/s
 Printed Name _____ Signature _____ USATF Cert # _____
6. **Field Judge Certificate:** We certify that the measurement stated opposite our respective signatures is exact as measured in accordance with IAAF or appropriate Rules. We also certify that the circle, sector and/or runway is in compliance with IAAF or appropriate specifications.
 Mark _____ m Printed Name _____ Signature _____ USATF Cert # _____
 Mark _____ m Printed Name _____ Signature _____ USATF Cert # _____
 Mark _____ m Printed Name _____ Signature _____ USATF Cert # _____
7. **Implement Certification:** I certify that I weighed and measured the implement used for the claimed record in accordance with IAAF or appropriate Rules and that the implement conforms exactly with relevant IAAF or appropriate Rule. For World Records, I further certify the implement as follows:
 Manufactured by _____ Model _____ IAAF Certification # _____
 Printed Name _____ Signature _____ USATF Cert # _____
8. **Surveyor:** I certify that the facilities used were in conformity with IAAF or appropriate Rules. The maximum allowance for inclination did not exceed 1:100 laterally and 1:1000 in the running direction. For running events, I have measured the course over which this event was held and the exact distance was:
 _____ meters _____ centimeters; or _____ miles _____ yards _____ feet _____ inches.
 For track events the length of one lap is as indicated below,
 _____ meters _____ centimeters; or _____ miles _____ yards _____ feet _____ inches.
 And (check one):
 There was a 5cm raised border on the inner edge of the track with cones used to replace the border as required.
 There was no raised border and cones were used as required. The one lap measurement was made 20cm from the inside of lane 1.
 Printed Name _____ Signature _____ Qualification _____
9. **Doping Control Certification:** As a member of the Doping Committee for the event, I certify that a sample for a doping test was obtained in accordance with IAAF or appropriate Rules from the named athlete(s) in my presence and dispatched to the following laboratory:
 Doping control date/time _____ Laboratory _____
 Printed Name _____ Signature _____ Qualification _____
10. **Guarantee by Referee:** I certify that all information recorded on this form is accurate, that the Officials conducting the event were duly qualified and that all IAAF or appropriate Rules of Competition were complied with.
 Printed Name _____ Date _____
 Signature _____ USATF Cert # _____

Instructions:

World Records and American Records

For running events, use sections 1, 2, 3 or 4, 8, 9, 10. Add section 5 for outdoor events less than 300m.
 For field events, use sections 1, 6, 7, 8, 9, 10. Add section 5 for outdoor Long Jump or Triple Jump.
 No application for an American Record is required for marks attained at championships conducted by USATF.

The following must be enclosed with this application for World and American Records:

- The printed program for the competition.
- The complete results for the event as well as a copy of the Results Card and the official results.
- A printed Photo Finish photograph in the case of a track record using fully automatic timing (exempted for some competitions).
- A report of all reaction start times in races where a false start detection system is required.

Revised January 2009

<https://www.usatf.org/resources/statistics/record-applications>

Appendix 3 : SPECIAL SECTION

ADAPTATIONS TO USA TRACK & FIELD RULES OF COMPETITION FOR PARA ATHLETES (ATHLETES WITH DISABILITIES)

INTRODUCTION

This section contains a summary of adaptations and modifications to USA Track & Field rules for competitions for Para Athletes. In this country, essentially all competitions for athletes with disabilities use the rules of World Para Athletics (WPA; IPC Athletics is now known as WPA). In the US there are only a few exceptions to the WPA rules, involving U14 and U11 competitions and Masters (M35, M50, M60), which are noted in this section (*and are identified by being in italics and within parentheses*). The WPA rules are based on World Athletics rules, therefore they also are compatible with the USA Track & Field rules. The WPA rules make modifications only as necessary to accommodate the particular method of competition for each type of disability. The following selected rule modifications have been reprinted, using the numbering of the USATF rule book, with permission from the WPA. For a complete set of the final approved WPA rules modifications, including administrative rules and guidelines for 2024, visit the WPA website (<https://www.paralympic.org/athletics/rules>).

WPA competition rules no longer included any Combined Events rules and, therefore, Combined Events are not contested in WPA World or Paralympic competitions. (*Combined Events may be contested at National level competitions.*)

As noted in USATF Rule 144.1, for athletes with disabilities entering open competitions, please refer to the “USATF Policy and Procedures for Evaluation of Requests for Accommodations Pursuant to the Americans with Disabilities Act” (<https://www.usatf.org/governance/policies/usatf-policy-procedures-for-evaluation-of-requests>).

Double leg amputee athletes competing in USATF open events must comply with the WPA Measurement Assessment of Standing Height (MASH). The height for any licensed athlete is available on the World Para Athletics classification master database.

In situations where an athlete with standard leg prostheses enters an open competition at the Association level, at the time of this writing the research appears to indicate that such prostheses, in general, are not in violation of Rule 143.3 or 144.3(c)(d).

Most rule modifications cited below are associated with a notation of disability class; e.g., “Classes T32-34, T51-54”. A letter prefix specifies Track events (T) or Field events (F). The numbers indicate the particular type and level of disability.

NOTE: *The following descriptions of classifications are for informational purposes only; track and field officials are not responsible for making classification decisions.*

Numbers in the low teens indicate Visually Impaired (VI) athletes:

- Class 11: No light perception in either eye up to light perception, but inability to recognize the shape of a hand at any distance or in any direction.
- Class 12: From ability to recognize the shape of a hand up to visual acuity of 2/60 and/or visual field of less than 5 degrees.
- Class 13: From visual acuity of above 2/60 up to visual acuity of 6/60 and/or visual field of more than 5 degrees and less than 20 degrees.

NOTE: All classifications is in best eye with best correction; i.e., all athletes who use contact or corrective lenses must wear them for classification, whether they intend to compete wearing them or not.

Class T20 indicates athletes with intellectual disabilities:

Athletes with Activity Limitations that result from an Intellectual Impairment and meet all standards below:

A. Significant impairment in intellectual functioning. This is defined as 2 standard deviations below the mean, that is, a Full Scale IQ score of 75 or lower.

B. Significant limitations in adaptive behavior as expressed in conceptual, social, and practical adaptive skills.

This is defined as at least 2 standard deviations below the mean of either

a) one of the following 3 types of adaptive behavior: conceptual, social, or practical skills, or

b) an overall score on a standardized measure of conceptual, social and practical skills.

C. Intellectual disability must be evident before age 18.

Numbers in the 30s indicate athletes with Cerebral Palsy, Stroke, and Traumatic Brain Injury (hypertonia, ataxia, and/or athetosis):

Class 31: Severe tetraplegic (quadriplegic)/triplegic – requires use of power wheelchair, more spasticity prevalent.

Class 32: Severe tetraplegic-wheelchair, may propel wheelchair with legs or arms, better upper extremity range of motion and coordination than Class 31, more athetosis present.

Class 33: Weak tetraplegic, triplegic or moderate hemiplegic – wheelchair.

Class 34: Paraplegic: good upper extremity strength and control – wheelchair.

Class 35: Paraplegic, moderate hemiplegic, may ambulate without wheelchair in regular and daily activities. May or may not use assistive devices as ambulatory support. NDSA defines assistive devices as ambulatory support devices such as crutches, walkers or canes. Braces are not considered assistive devices.

Class 36: Tetraplegic athetoid - severe triplegic, usually ambulates without walking aids, athetosis more prevalent.

Class 37: Moderate hemiplegic or moderate to minimal tetraplegic.

Class 38: Minimally disabled group.

Numbers in the 40s indicate Dwarfs, Lower Limb Impairment (not using prostheses) and Arm Amputees:

Class 40: Short persons of shorter stature.

Class 41: Short persons of taller stature.

Class 42: Unilateral/bilateral above knee impairment (impaired muscle power or range of motion) competing without prosthetics.

Class 43: Bilateral below knee impairment (impaired muscle power or range of motion) competing without prosthetics.

Class 44: Unilateral below knee impairment (impaired muscle power or range of motion) competing without prosthetics. (See new Class T/F61-64 below for amputee classes.)

Class 45: Bilateral arm amputation above the elbow or equivalent.

Class 46: Unilateral arm amputation above the elbow or equivalent.

Class 47: Unilateral arm amputation below the elbow or equivalent.

Numbers in the 50s indicate athletes with Spinal Cord Injuries (impaired muscle power, impaired passive range of motion, and/or limb deficiency). Athletes are divided by their physical level of function. Track has four level of function, listed from weakest to strongest:

- Class T51: These athletes have no hand function, are unable to use the muscles that straighten their elbows, and their hands remain in contact or close to the pushing rim with the power coming from their elbow flexion. Neurological level: C6
- Class T52: These athletes have limited or no hand function. Power for pushing now comes from elbow extension, wrist extension and active chest muscles. Their head may be forced backwards (by the use of neck muscles), producing slight upper trunk movements even though they do not have use of their trunk muscles. Neurological level: C7-C8.
- Class T53: These athletes have normal or nearly normal upper limb function. There is no active trunk movement, although the trunk may move with the pushing action; otherwise the trunk is usually lying on the tucked up legs. They tend to interrupt pushing movements to steer, then have difficulty resuming the pushing position. When braking, the trunk stays close to the pushing position. Neurological level: T1-T7.
- Class T54: These athletes have normal upper limb function as well as backward movement of the trunk, often with rotation movements of the trunk. They may use the trunk movements to steer around curves, and usually do not have to interrupt the pushing stroke rate around curves. When stopping quickly, the trunk moves toward an upright position. They are able to use their abdominals for power, particularly when starting, but also when pushing. Neurological level: T8-S2.

All athletes compete in the 100m, 200m, 400m, 800m, 1500m, 5000m, and 10,000m. Relays include the 4x100m, 4x400 m, and Universal Relay.

Field has seven functional classes, from weakest to strongest:

- Class F51: These athletes have no grip or ability to extend the arm or use their trunk or legs. They use resin or adhesive substance for grip. The discus is thrown with a flat trajectory. Their other implement is a “club” that is hooked between the fingers and thrown forward, or backward over their hand (using strong elbow flexors). Neurological level: C6.
- Class F52: These athletes have difficulty with gripping, but are able to extend their arm. (No use of trunk or legs.) Shot: They are unable to form a fist, and therefore do not usually have finger contact with the shot at the release point. Discus: They have difficulty placing the fingers over the edge of the discus, but may do so with the aid of contractures or spasticity. Javelin: They usually grasp the javelin between the fingers. Neurological level: C7.
- Class F53: These athletes have nearly normal grip, no use of trunk or legs. Or they have hand function of F52 with trunk muscles. Shot: Usually a good fist can be made, so they are able to use some spreading of the fingers and can “grasp” the shot when putting. Discus: They have good finger function to hold the discus, and may be able to impart spin to the discus. Javelin: They usually grip the javelin between the thumb and index finger. They have the ability to hold the javelin because of the ability to use hand muscles that spread and close the fingers. Neurological level: C8.

- Class F54: These athletes have normal or nearly normal hand function, but no sitting balance, or they have hand function of F53 with trunk muscles. They put the shot, and throw the discus and javelin. Usually they hold onto part of the chair for balance while throwing. Some athletes in this class will have normal hand function, but no functional trunk movements. Others will have some trunk movements, but hand function such as F53. Neurological level: T1-T7.
- Class F55: Three trunk movements may be seen in this class: 1) off the back of the chair (in an upward direction); 2) movement in the forward and backward plane; and 3) some trunk rotation. They have fair to good sitting balance. They do not have functional hip movement, so do not have the ability to lift the thigh upward in sitting. They may have stiffness of their spine that improves balance, but reduces the ability to rotate the spine. With the shot and javelin, they tend to use forward and backward movements, whereas with the discus they predominantly use a rotary movement. Neurological level: T8-L1.
- Class F56: These athletes also put the shot and throw the discus and javelin. They have very good balance and movements in the forward and backward plane, with good trunk rotation. They can lift their thighs off the chair and press the knees together. Some have the ability to straighten and bend their knees. Neurological level: L2-L5.
- Class F57: These athletes also have the ability to move side to side, so they can throw across their body. They usually can bend one hip backward to push the thigh into the chair, and can bend one ankle downward to push down with the foot. Neurological level: S1-S2. (Athletes in this class choosing to compete standing rather than seated are classified as Class 42-44, depending on level of function.)

Athletes compete in the shot put, discus, javelin and club (F31-32 and F51). All classes F51-F57 throw in a seated position from a throwing frame within a throwing circle 2.135m to 2.50m in diameter. Frames are tied down with various types of straps and hooks to assure the frame does not move during their throw. It is not necessary for the frame to have wheels. Throwing cages are advisable for the discus and club to protect others. (Regular wheelchairs may be used if they adhere to the throwing frame specifications).

Athletes with leg amputations or equivalent compete in track and field in four classes:

- Class 61: Athletes with bilateral above knee limb deficiency (amputation/dysmelia) competing with prostheses.
- Class 62: Athletes with bilateral below knee limb deficiency (amputation/dysmelia) competing with prostheses.
- Class 63: Athletes with unilateral above knee limb deficiency (amputation/dysmelia) competing with prosthesis.
- Class 64: Athletes with unilateral below knee limb deficiency (amputation/dysmelia) and leg length difference competing with prosthesis.

The following are the 2023 rule modifications to World Athletics/USATF rules for competitions for athletes with disabilities, based on WPA rules. **The rule numbers noted refer to the USATF Rule Book (although there may be slight discrepancies due to any modification of rule numbering for this year's version of the rule book). While the rule modifications presented here should cover most situations, if there is any question not immediately answered by the following, then see the WPA rule book (<http://www.paralympic.org/athletics/rules>) for further clarification.**

Further modifications applicable only to USA competitions under Adaptive Track & Field USA (ATFUSA) rules for U11 and U14 athletes and Master athletes (M35, M50 and M60) are italicized.

Full ATFUSA rules and exceptions that cover all athlete with disabilities divisions are available on the ATFUSA.org website - <http://www.atfusa.org/RULES/RULES.htm>

ARTICLE III – OFFICIALS

Rule 129: Starter and Recall Starters

Rule 129.5 (Classes T32-34, T51-54)

Add: Note 2: In wheelchair races of 800m or longer the starter has the authority to recall a race for a restart if a collision involving athletes in the race occurs in the first 50m. This does not reduce or remove the authority of the Referee to take appropriate action on reports received from umpires during this portion of the race.

Rule 136: Clerk of Course

Rule 136.5

Add to text: The Clerk of Course shall be responsible for inspection of eye gauze patches masks & tethers, racing chairs and throwing frames, ensuring they meet required specifications, and shall be responsible for measurement of Maximum Allowable Standing Height (MASH) for athletes wearing prosthetic legs (Class 61-62).

ARTICLE IV - RULES OF COMPETITION

Add: Rule 141.4: Classifications

Rule 141.4 (All Classes)

The following age groups are recognized by WPA or ATFUSA Athletics:

- (a) Masters Men and Women: Any athlete who has reached his/her 35th (M35), 50th (M50) or 60th (M60) birthday.
- (b) Under 23 (U23) Men and Women: Any athlete 20, 21 or 22 years old on December 31 in the year of the competition.
- (c) Under-20 (U20) Men and Women: Any athlete 17, 18 or 19 years old on December 31 in the year of the competition.
- (d) Under-17 (U17) Boys and Girls: Any athlete 14, 15 or 16 years old on December 31 in the year of the competition.
- (e) ATFUSA Under 14 (U14) boys and girls: Any athlete of 11,12 or 13 years on December 31 in the year of competition.*
- (f) ATFUSA Under 11 (U11) boys and girls: Any athlete of 7,8,9 or 10 years on December 31 in the year of competition.*

Note: An athlete must be 14 by December 31 in the year of competition to compete in an open event.

Rule 143: Athletic Attire

Rule 143.1 (Classes F32-34, F51-57)

Add: Note: In field events clothing must be close fitting, and not be loose, so that the view of the judges is not impeded.

Rule 143.4(b) (Classes T31-34, T51-54, F32-34, F51-57)

Add: Note1: Every athlete must be provided with an additional number bib to be worn visibly on the back of the chair, athlete, or throwing frame.

Rule 143.4(b) (Classes T32-34, T51-54)

Add: Note 2: In all individual and team track and road wheelchair races, these hip numbers shall be worn on the helmet.

Add: Rule 143.11 (Classes T/F35-38, T/F42-47, F51-57, T/F61-64)

Athletes may wear a prosthetic or orthotic device(s) in order to ensure both legs or arms are of equal length or balanced.

Prosthetic(s) or orthotic(s) are required to comply with WPA "spirit" of the influence of technology on equipment guidelines contained in Article 3.5: Technology & Equipment [in the WPA rule book].

Prosthetic(s) or orthotic(s) should be reviewed by the Technical Official responsible for checking athletic equipment at WPA Approved Competitions. They should advise the WPA Technical Delegate regarding any equipment that they believe may breach the guidelines contained in Article 3.5: Technology & Equipment prior to the commencement of the respective event. The WPA Technical Delegate can rule whether or not the equipment can be used during the respective event.

Add: Rule 143.12 (Classes T61-64)

In track events athletes in Sports Classes T61-64 must use leg prostheses and shall complete the race with those devices. [The prohibition against hopping to the finish line is no longer in effect; if the prosthesis comes off or is broken, the athlete may hop across the finish line but must be carrying the prosthesis when finishing.]

Note: The use of other assistive devices to facilitate running is not allowed.

Add: Rule 143.13 (Classes F61-64)

In field events athletes in Sports Classes F61-64, the wearing of prostheses is optional.

Add: Rule 143.14 (Classes T/F61-64)

The actual height of leg amputees in the competition prostheses shall not exceed the Maximum Allowable Standing Height (MASH) in accordance with WPA Classification Rules and Regulations. The MASH heights for each athlete in these classes must be made available to the Clerk/Call Room officials, and measurements made by Clerk/Call Room officials upon each entry into the competition area.

Add: Rule 143.15 (Class T/F11)

Athletes in Classes T/F11 must have their eyes/eye cavities completely covered by gauze patches or an equivalent material, and wear approved opaque glasses or an appropriate substitute during all track and/or field events. These opaque glasses or their substitute must completely cover the eyes of the competitor and must be checked and approved by the responsible Clerk Area technical official and in their opinion be effective in blocking out all light. The opaque glasses or their substitute may be inspected again at any time, including immediately before the start and/or after the finish. When the athlete is not competing, the opaque glasses or their substitute may be removed.

Note (i): Eye patches and opaque glasses or appropriate substitute must be worn from the time the athlete leaves the Clerk Area until the end of the event except that the

athlete may remove the eye mask (and opaque glasses or appropriate substitute) between trials in the event.

Note (ii): It is the responsibility of the athlete to ensure that these eye patches and opaque glasses or appropriate substitute meet this requirement.

Note (iii): It is not required for athletes to wear eye patches and masks during road races.

Add: Rule 143.16 (Classes T31-34, T51-54)

The wearing of helmets is compulsory in all individual and team track races and in all road races. The helmet shall be a hard protective shell that meets a recognized international safety standard (e.g., Snell b-84/90/95; BSI 6863; EN 1078).

Rule 144: Assistance to Athletes

Add: Rule 144.3(g) (Classes T/F11-12, F31-32, F51-54)

Guide-runners for Classes T/F11-12 athletes, and Assistants for athletes in Classes F31-32, F51-54 will be permitted to accompany athletes onto the competition area. Guide-runners or Assistants must be clearly identified by wearing a distinctively colored vest provided by the Local Organizing Committee. (Assistants for other class athletes may be allowed via a request form presented to and approved by the Referee.)

Add: Rule 144.3(h)

Ambulant athletes who are competing from a standing position are not allowed to use a wheelchair to access the field of play.

Add: Rule 144.3(i) (Classes F31-32, F51-54)

Athletes in Classes F31-32, F51-54 are permitted one Assistant per event who can assist:

- (a) officials to ensure the athlete transfers safely to the throwing frame, and
- (b) athletes to strap themselves to their throwing frame.

The Assistants must withdraw from the competition area once they have completed these tasks and must follow any directives from the officials of the event while they are in the competition area.

Note: Strapping: If used must be only to the frame with non-elastic material.

ATFUSA exception: All Class/Age Group seated throw athletes not in a WPA licensed throwing event may use an Assistant to help get them into the field chair and strap in, without a request form.

Add: Rule 144.3(j) (Classes T11-12)

Athletes in Classes T11-12 are encouraged to provide their own guide-runners. However, the organizers should provide an appropriate guide-runner if the need has been indicated on the entry form in advance following the “request for a guide-runner” requirements of the Local Organizing Committee. Athletes in Class T11 are required to use a guide-runner; athletes in Class T12 have the option of using a guide-runner or competing by themselves. A T12 athlete not using a guide-runner may have an assistant accompany the athlete through the Clerk Area up to the start area. The assistant shall withdraw from the field of play prior to the start of the race. In international competitions athletes in Class T11 (and T12 if used) must provide their own guide-runners. (Athletes in classes T11 and T12 (T12 with or without a guide) will be given 2 lanes on the track (1-2, 3-4, 5-6, 7-8)).

Add: Rule 144.3(k) (Classes T11-12)

When competing with a guide-runner, the method of guidance for athletes in Classes T11-12 shall be the use of a tether of non-elastic material with a maximum length of 30cm, or 50cm for road races. The tether attachment shall only be established between

hand(s) and/or arm(s) of the pair. In addition, the runner may receive verbal instruction from the guide-runner. The guide is not allowed to use a bicycle or other mechanical means of transport.

Note: The pair shall retain the tether attachment from the start of the race until the end of the race. No release shall be allowed until after the athlete and the guide both finish the race, except during the process of interchange of guide-runners.

(The tether will have a closed loop at each end. See WPA rules for more details on construction of tether.)

Add: Rule 144.3(l) (Classes T11-12)

The guide-runner is not allowed to pull or propel the athlete in Classes T11-12 in order to gain an advantage at any stage during the race.

Note (i): Slingshotting is regarded as a technique whereby the guide-runner deliberately hurls his arm (attached to the athlete) forward in order to exert a propulsion toward the athlete's running direction. Such a technique is not permitted at any stage during a race.

Note (ii): A guide-runner may assist an athlete who has tripped or fallen to regain his footing and/or orientation as long as such assistance does not provide any advantage to the athlete toward his running direction.

Add: Rule 144.3(m) (Classes T11-12)

For races further of 5000m or longer athletes in Classes T11-12 are allowed to use two (2) guide-runners. However, only one (1) interchange of guide-runners is permitted for each athlete per race. The interchange must take place without any hindrance to other athletes, and must take place only on the back straight. The intention to interchange guide-runners must be notified in advance to the Referee and Technical Delegate. The technical officials will determine the conditions of the interchange and will communicate these in advance to the athletes. If declared, the second guide-runner must be used.

Add: Rule 144.3(n) (Classes F11-12)

An Assistant may bring athletes to the throwing circle or runway. The Assistant may assist the athlete by orienting them within the throwing circle or on the runway before each attempt. The Assistant must leave the circle or runway before the attempt begins. Acoustic orientation is permitted before, during and after each attempt by the assistant standing to the side of the runway (not in the pit) or in the sector for throws. Athletes may only be guided from the circle or runway after the officials have determined whether or not the attempt was a valid one (exited properly from the pit or circle).

Note: If the official in charge of the event decides that an Assistant who is providing acoustic orientation is in an unsafe location then the official has the right to require the Assistant to move.

Add: Rule 144.3(o) (Class F11)

For athletes in Class F11, acoustic signals are permitted during the Long Jump, Triple Jump and High Jump. However, no visual modification to the existing facility is permitted. In events where acoustic assistance is being used complete silence shall be requested from spectators.

Note: Whenever possible, to ensure silence, events in which acoustic assistance is being used should not be timetabled together with other running events.

Add: Rule 144.3(p) (Class F11-12)

During jumping events athletes in Class T11 can be accompanied onto the field of play by two assistants (T12 one assistant) to:

a) act as a caller to provide acoustic orientation during the approach run in High Jump, Long Jump and Triple Jump, and/or;

b) act as an escort to assist the athlete by positioning him on the runway before each attempt.

Note (i): Acoustic orientation is permitted before, during and after each attempt. Once an attempt has begun, only acoustic orientation is allowed by the assistant(s) until after the officials have determined whether or not the attempt was a valid one.

Note (ii): The assistant(s) may be positioned on or beside the Long or Triple Jump runway or behind the landing area. The assistant(s) may be in front of or behind the take-off area, but shall not stand in the take-off area (powdered area) or landing area.

Note (iii): The assistant(s) must not stand in a position that hinders the view of Officials nor run along-side or behind the athlete during an attempt.

Add: Rule 144.3(q) (Class F12)

For athletes in Class 12, visual modification of the existing facility is permitted during field events (i.e., Paint, chalk, powder, cones, flags, etc.) at the discretion of the Technical Delegate or Referee. Acoustic signals may also be used.

Add: Rule 144.3 (r) (Classes T/F11-12)

No guide animals shall be permitted in the competition area.

Add: Rule 144.3(s) (Classes T20, T35-38, T42-T47, T61-64)

Some athletes in Classes T20, T35-38, T42-47 and T61-64 may require their starting blocks to be set for them, or their runway markers to be at a preset distance from the take-off board, prior to the competition. The Technical Delegate (or Referee) will provide the appropriate athletes with a document on which to show their requirements.

Note: WPA recognizes the special needs of deaf-blind athletes, and is keen to encourage and facilitate their participation in competition. In cases where deaf-blind athletes are competing in an event, some “common sense” modification to current WPA Rules may be necessary. Such modification should only be permitted with the prior approval of the Technical Delegate. In principle, no rule modification that disadvantages any other athlete will be allowed.

Rule 144.7 (Classes T11-T12)

Add: Note: In events of 800m and above, people other than officials may call intermediate times from an area inside the competition area that has been designated for that purpose by the appropriate Referee.

Rule 145: Disqualification

Add: Rule 145.6 (Classes 51-57)

Athletes must ensure that urine is not allowed to drain from storage devices such as leg bags onto the competition or warm up areas. Failure to do so may result in disqualification.

Add: Rule 155: Wheelchair Track (Classes T33-34, T51-54)

Rule 155.1 The wheelchair shall have two (2) large wheels and one (1) or two (2) small wheels. The small wheel(s) must be at the front of the chair. (Note that in Paralympic Games, WPA Paralympics, World Championships and Regional Championships wheelchairs shall have two large wheels and ONLY one (1) small wheel.)

Rule 155.2 (a) No part of the frame of the wheelchair, or any attachments to it, shall extend forward beyond the hub of the front wheel nor backwards beyond the rearmost vertical plane of the rear wheels (including tires). Additionally, the width of the frame,

and any of its attachments, shall not be wider than the inclined plane of the pushing rims (as outlined in Figure A).

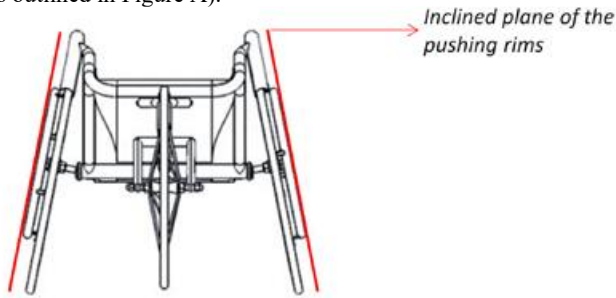

Figure A – Inclined plane of the pushing rims

COMMENT: Call Room Judges will inspect all wheelchairs to ensure no attachments are outside of the inclined plane of the pushing rims.

(b) The maximum height from the ground to the main body of the wheelchair shall be 50cm. (c) No part of the wheelchair may protrude behind the vertical plane of the back edge of the rear tires.

Rule 155.3 (a) The maximum diameter of the large wheel including the inflated tire shall not exceed 70cm. (b) The maximum diameter of the small wheel including the inflated tire shall not exceed 50cm.

Rule 155.4

Only one plain, round, push-rim is allowed for each large wheel.

Note 1: This rule may be waived for persons requiring a single arm drive chair, if so stated on their medical or classification form or at the discretion of the Technical Delegate (or Referee) in consultation with the Chief Classifier.

Note 2: For T33/T51-52 athletes with limited ability to stabilize the wrist during pushing, this rule may be waived and a modification allowed so that a push-rim and wheel disc may be fused together and incorporated into the racing wheel. No other modification that would defeat the general intent of this rule is allowed.

Note 3: No part of the athlete's body shall be strapped to the push-rim or the wheel.

Rule 155.5

No mechanical gears or levers are allowed to propel the wheelchair. All wheelchairs must have a functional braking system.

Rule 155.6

Only hand operated, mechanical steering devices are allowed.

Rule 155.7

In all races, the athlete must be able to turn the front wheel(s) manually both to the left and to the right.

Rule 155.8

The use of mirrors is not permitted in wheelchair track or road races.

Rule 155.9

Wheelchairs will be measured and inspected in the Call Room and must not leave that area before the start of the event. Wheelchairs can be re-examined by the officials before or after the event.

Rule 155.10

Athletes must ensure that no part of their lower limbs can fall to the ground or track during the event.

Rule 155.11

It is the responsibility of the competitor to ensure the wheelchair conforms to the requirements stipulated above. No event shall be delayed while an athlete makes adjustments to the wheelchair.

Rule 155.12

It shall be the responsibility of the Technical Officials (i.e., Judges and Referees) to rule on the safety of the wheelchair and the athlete using it.

Rule 155.13

No element of the wheelchair or its attachments or accessories may incorporate energy storing capacity (e.g., elasticity) for the purpose of enhancing performance. Devices attached to the wheelchair or athlete shall comply with Rule 144 (Assistance) and shall not have the capability to communicate except to the athlete.

Note: Unless approved by the WPA and the Technical Delegate (or Referee), no devices with transmission function for the purpose of event presentation or broadcasting shall be permitted at WPA Recognized Competitions.

COMMENT: Any physical or technological action or activity that provides an athlete with an unfair advantage is not permitted on the field of play. Any device that has the capacity to be used for communicating is prohibited from the field of play. Speedometers attached to wheelchairs that have a GPS component may be allowed as long as communication function is not included.

Call Room Judges will inspect the racing wheelchair frame as well as the helmet and athlete's ears to ensure the athlete is not in possession of any device that has the capacity to communicate.

Note that further inspections may be conducted at any time.

For Class T31-32, Rules 155.1-12 apply to this class with the following exceptions:

a) In all competitions only the Race Running frame shall be used. The frame has two rear wheels and one front wheel. Maximum length 200 cm, maximum width 95cm. All wheels Max height size up to 72cm (see figure below). Saddle may have other shapes than the traditional type of racing cycle saddles. The body support plate may be individually shaped to provide optimal stability. The body may be strapped to the plate with a belt or orthopedic brace. The handle bars should ensure that the athlete is able to race and maneuver safely. A compensator system controlling the front wheel is highly recommended. No mechanical gears or engine are allowed. If the athlete is able to use a brake, it should be installed.

The athlete's hands may be strapped to the handlebars.

b) The athlete may propel the chair with the feet and can do so forward or backward.

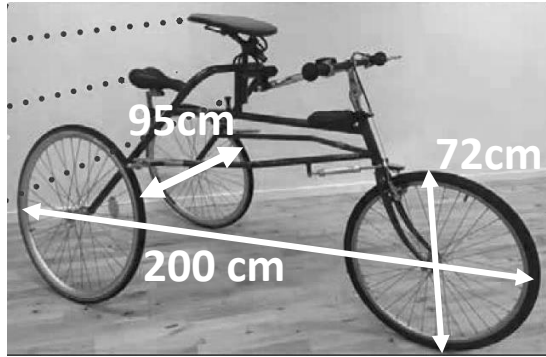

Rule 161: Starting Blocks

Rule 161.2 (Classes T35-38, T42-47, T61-64)

In the first line replace “shall” with “may” in relation to the application of this rule to athletes in Classes T35-38, T42-47 and T61-64. (In effect, this means only Classes T11-13 and T20 are required to use starting blocks.)

Add: Note 3: A four-point stance is not required by athletes in any of these Classes (Classes T35-38, T42-47, T61-64). It is acceptable for arm amputee athletes or those with short arms to use pads on which to rest stumps at the start or to improve balance. Pads must be completely behind the start line and not interfere with any other athlete. The pads should be a similar color to the track or of a neutral color. As per Rule 144.3(v), some athletes in Classes T35-38, T42-47 and T61-64 may require their starting blocks to be set for them prior to the competition. The Technical Delegate (or Referee) will provide the appropriate athletes with a document on which to show their requirements.

Note 4: It is not a requirement for athletes in classes T35-38, T42-44 and T61-64 to use both foot plates when using a starting block.

Note 5: Use of a personal starting block shall require approval from the Technical Delegate (or Referee).

(ATFUSA exception for U11 and U14 Athletes: For athletes in Classes T11-13 and T20, the general rules regarding the use of starting blocks are waived. The use of starting blocks and stance is within the discretion of the competitor.)

Rule 162: The Start

Rule 162.5 (Classes T11-13, T20, T35-38, T40-47, T51-54, T61-64)

Add: Note: Where a competitor has a hearing impairment, a flag or other visual device may be used as well as a pistol to signal the start. In some circumstances, for athletes with both a visual and a hearing impairment, an official may touch an athlete to signal the start.

Rule 162.9 (Classes T31-34, T51-54)

Replace with: After the “On Your marks” command, an athlete shall approach the start line, assume a position entirely within his allocated lane and behind the start line. At the “Set” command, an athlete shall immediately take up his final starting position retaining the contact of the front wheel with the ground behind the line.

Rule 162.16 (Classes T32-34, T51-54)

Add: Note 2: As per Rule 129.4 (Note 2), in wheelchair races of 800m or longer the starter has the authority to recall a race for a restart (but is not obliged to do so) if a collision involving athletes in the race occurs in the first 50m. This does not reduce or remove the authority of the Referee to take appropriate action on reports received from umpires during this portion of the race.

(ATFUSA exception for U11 -U14: For all U14 and younger class athletes competing in track events the zero false start rule is amended to allow one false start on the field before an athlete is disqualified.)

Rule 163: Running Competition

Rule 163.4 Add: Note 3: The provisions of Rule 163.4 apply to both the athlete and guide-runner in Classes T11-12. Athlete(s) in Classes T11-12 under this rule shall refer to athlete(s) and/or guide-runner(s). In the event of a breach of the rule committed by a guide-runner resulting in disqualification or warning, the accompanying athlete shall be consequently disqualified or warned.

Rule 163.5 (Classes T31-34, T51-54)

Add: Note 3: In the wheelchair / race runner 800M, the athlete must stay in the assigned lane until the bottom of both rear wheels have crossed the break line. For wheelchair races, cones should not be placed on the track at the break line, although colored flat markers may be placed at the intersection of the break line and the lane lines. Large cones should be placed on the inside and outside of the track to mark the break line.

Add: Rule 163.16 (Classes T33-34, T51-54)

During wheelchair races propulsion by any other method except the athlete pushing on the wheels or push-rims will result in disqualification.

Add: Rule 163.17 (Classes T31-34, T51-54)

During wheelchair / race runner races an athlete coming from behind in an attempt to overtake carries the responsibility of ensuring full clearance of the chair being overtaken before cutting across. The athlete being overtaken has the responsibility not to obstruct or impede the incoming athlete once the front wheel(s) of the athlete are in sight.

Add: Rule 163.18 (Classes T11-12)

Athletes in Class 11 compete accompanied by a guide-runner for all track events. In the 100m, 200m and 400m events each athlete and guide-runner shall be allocated two lanes. The start lines in a staggered start will be those for lanes 1, 3, 5, 7. This rule also applies to 800m events started in lanes.

Class 12 athletes have the option of being accompanied by a guide-runner for all track events. In the 100m, 200m and 400m events each athlete and guide-runner shall be allocated two lanes (whether or not a guide is used). The start lines in a staggered start will be those for lanes 1, 3, 5, 7. This rule also applies to 800m events started in lanes.

Rule 164: The Finish Line

Add: Rule 164.6 (Classes T31-34, T51-54)

In wheelchair / race runner races the athletes shall be placed at the finish in the order in which the center of the axle of the leading wheel reaches the vertical plane of the nearer edge of the finish line as defined above.

Add: Rule 164.7 (Classes T11-12)

In races for athletes in Classes T11-12 competing with a guide-runner, the athlete must cross the finish line in front of the guide-runner or the athlete will be disqualified.

Add: Rule 164.8 (Classes T31-34, T51-54)

Event time limits: In wheelchair / race runner races of 1,500m or longer, officials may conclude the event and clear the track after the agreed time limit has expired. Any athlete who has not completed the set distance when an event is concluded shall be shown in the official results as “DNF” (Did not finish). The Referee has the authority to remove any athlete who has been lapped.

Rule 165: Timing

Rule 165.4 (Classes T32-34, T51-54)

Add: In wheelchair / race runner races the time shall be taken to the moment at which the center of the axle of the leading wheel of the athlete’s chair reaches the vertical plane of the nearer edge of the finish line.

Rule 166: Regulations for Forming Heats

Rule 166.1(a) (Classes T11-13)

Add: Note 2: Track events in Classes T11-13 should have the following maximum numbers (exclusive of guide-runners) assuming an eight-lane track:

Event	T11	T12	T13
100m	4	4	8
200m	4	4	8
400m	4	4	8
800m	4/5*	5*	8
1,500m	6	6	10
5,000m	10	10	20
10,000m	10	10	20

* = depending on starting arrangements.

Rule 170: Relay Races

Add: Rule 170.0 4X100m or 4X400m Relay team composition

(Classes T11-13) The relay team must include a minimum of one Class 11 and not more than one Class 13 runner.

(Classes T33-34) The relay team must include at least one athlete from Class T33.

(Classes T35-38) Can include a maximum of two Class T38 athletes.

(Classes T42-47 & T61-T64) Can include a maximum of two Class T46/47 athletes.

(Classes T51-52) Must include at least one Class T51 athlete.

(Classes T53-54) Must include at least one Class T53 athlete.

4x100m Universal Relay team composition, running order and eligible Sport Classes are as follows:

- (a) Each team must include two (2) male and two (2) female eligible athletes.
- (b) A maximum of two (2) athletes must be selected from the following Sport Classes: T13, T46/47, T38, T54.
- (c) The remaining two (2) athletes must be selected from any of the other Sport Classes outlined in the table below.
- (d) The running order must be in accordance with the below table:

Running Order	Eligible Classes
First Leg	T11-13
Second Leg	T42-47, T61-64
Third Leg	T35-38
Fourth Leg	T33-34, T51-54

- (e) The 4x100m universal relay race shall be run entirely in lanes, with each team assigned two lanes.

Rule 170.3 (Classes T32-34, T51-54)

Add: Note: In wheelchair relays of 4x100m and 4x400m members of a team, other than the first athlete and the third take-over of the universal relay, have an extended zone 10m outside the take-over zone. A distinctive mark shall be made in each lane to denote this extended zone. (This in effect gives wheelchair athletes a 40m exchange zone for the 4x100 and 4x400 relays.)

Rule 170.6 (Classes T32-34, T51-54)

Add: In any wheelchair relay race, when lanes are not being used, including when applicable, in 4x200m and 4x400m, waiting athletes will be allocated two adjacent lanes, in their order in accordance with Rule 170.14. The waiting athletes may use either of these two lanes but must remain in these two lanes until after the takeover has been completed. In wheelchair relay races waiting athletes cannot take up an inner position or any other position than in the two allocated lanes. If an athlete does not follow this Rule, his team shall be disqualified. [It is recommended that the LOC provide each relay team with color coded helmet covers/socks to provide officials with a better view of tags and transitions.]

Rule 170.6 (Classes T11-13, T32-34, T51-54)

Add: Note: For wheelchair relays and relays for Classes T11-13 (i.e., involving guide-runners), where it is required for the relay to be run in lanes, each team shall be allocated two adjacent lanes. The athletes may use either of their two allocated lanes. The lines on the inner of the two allocated lanes shall be extended across the outer of the two allocated lanes to mark the distances of the stages (i.e., exchange zones) and to denote the scratch lines. Changes will take place as for lanes 1, 3, 5 and 7. The extension of start and exchange box lanes should be done with tape of the same color as the existing lane markings.

Rule 170.18 (Classes T33-34, T42-46, T51-54, T61-64)

Add: For wheelchair relays (T33-34, T51-54) and ambulant relays (T42-47, T61-64) the take-over shall be by a touch on any part of the body of the outgoing athlete. The first touch must be within the take-over zone. Pushing an outgoing athlete to gain advantage during take-over shall result in disqualification.

Note: For the 4x100 universal relay, the helmet worn by the wheelchair athlete is considered as a part of the body.

Add: Rule 170.25 (Classes T11-13)

(a) Either the athlete or the guide-runner can carry the baton. (b) The baton exchange may take place between either guide-runners or athletes without restriction, except that the conditions of the method of guidance as per Rule 144.3(q) must be met (i.e., athlete and guide-runner must be tethered). (c) A fair exchange is established when the baton carrier passes the baton to the baton receiver within the take-over zone. (d) Once the outgoing runner leaves the take-over zone, if no exchange was made with the incoming runner, they can re-enter the take-over zone to receive the baton (i.e., they go too early). (e) One Assistant per exchange zone will be allowed on the track to help with the positioning of any Class T12 athlete competing without a guide-runner. The Assistant must leave the competition area prior to the start of the event and must remain in a position that does not interfere with the conduct of the race.

SECTION III - FIELD EVENTS

Add: Rule 178: Specific Field Rules

Rule 178.1 (Classes F31-34, F51-57)

1. Throwing Frame Specifications:

- a) The maximum height of the seat surface, including any cushioning, shall not exceed 75 cm;
- b) Each throwing frame must have a seat which is square or rectangular in shape and each side at least 30 cm in length. The seat surface must be level or with the front higher than the back (i.e. inclined backwards).

NOTE 1: The front is the plane furthest from the athlete's spine with the athlete in a seated position regardless of the direction of the athlete in relation to the landing area.

NOTE 2: The corner(s) of, or notches in, the seat surface may be cut to accommodate side and/or back rests or a holding bar into the main throwing frame. The size of these cuts shall not be appreciably more than the space needed to insert the rests or the holding bar in them. The overall shape of the seat shall remain square or rectangular.

- c) The seat may incorporate side, front and back rests for the purposes of safety and stability. They can either be made of non-elastic fabric (e.g., non-elastic canvas) or be a rigid construction that does not move (e.g., rigid steel or aluminum). The rests may incorporate cushioning that must not exceed 5 cm in thickness.
- d) The side, front and back rests should not incorporate springs or movable joints or any other feature that could assist with propulsion of the throwing implement;
- e) The throwing frame may have a rigid vertical bar. The vertical bar must be a single, straight piece of material without curves or bends, and with a cross-sectional profile that is circular or square, not oval or rectangular. It must not incorporate springs or movable joints or any other feature that could assist with propulsion of the throwing implement;

NOTE 1: It is understood that most materials will flex and distort to some degree under pressure and it will not be practical or economically viable to engineer a solution whereby all flexing is totally eliminated. However, flexing must not be clear to the naked eye and in the opinion of the technical officials the spirit of these rules and Regulation 3.3 is not being breached. (Best practice: Bar should not deflect more than the width of the bar to the Official's eye).

NOTE 2: The vertical bar may have layers of tape and/or any other suitable material to provide a better grip. The thickness of the tape or other alternative material must

not result in any unfair advantage exceeding athlete's physical prowess (e.g., no thick ball of tape on the bar).

- f) No part of the throwing frame, including any vertical bar, shall move (save for incidental movement that cannot reasonably be eliminated) during the throwing action.
- g) Footplates, if used, are for support and stability only.
- h) A daily wheelchair that satisfies these criteria is acceptable (including the requiring that it must not move during the throwing action).

Rule 178.2 (Classes F31-34, F51-57)

Throwing frames will be measured and inspected in the Call Room/Clerk Area or at the competition area prior to the commencement of the event. Once it has been measured and inspected, an athlete's throwing frame must not be taken from the competition area before the start of the event. Throwing frames can be re-examined by the officials before, during or after the event.

Note: Measurement will always take place without the athlete sitting in the frame.

Rule 178.3 (Classes F31-34, F51-57)

It is the responsibility of the athlete to ensure that the frame conforms to the requirements stipulated above. No event shall be delayed while an athlete makes adjustments to their throwing frame.

Rule 178.4 (Classes F31-34, F51-57)

All Secured throwing events should be conducted from a circle, diameter 2.135m to 2.50m, into a sector as described in Rule 187. Movable platforms can be used at the discretion of the Technical Delegate (or Referee). The platform does not have to be a full circle, but in these circumstances the front arc or semi-circle must be designed to give the same effect of throwing from a circle, diameter 2.135m to 2.5m, and not alter the angle of the sector.

ATFUSA exception: Seated throws may be conducted in a level field. A cage or netting should be provided for the discus and club event.

Rule 178.5 (Classes F31-34, F51-57)

When positioning and securing the throwing frame inside the competition area all parts of the throwing frame, vertical bar and footrests must remain inside the vertical plane of the rim of the circle throughout the trial. (Note that the WPA has confirmed that if an athlete's feet are fastened to footplates that are off the ground, any part of the foot that protrudes from the plate can be outside the vertical plane of the circle as long as the foot does not touch the ground.)

Rule 178.6 (Classes F31-34, F51-57)

A reasonable time will be permitted for an athlete's throwing frame to be secured in the circle before the athlete attains a seated position on the throwing frame. The maximum time allowed is for athletes to attain the seated position, secure themselves to the chair and have as many warm-up throws as time permits. This time should not exceed:

- (a) 4 minutes for Classes F32-34 and F54-57, or
- (b) 5 minutes for Classes F31 and F51-53.

Note 1: Timing should begin at the time the chair is oriented, secured to the throwing platform and made available to the athlete to secure themselves into position.

Note 2: If the event is held in two sets of three throws instead of six straight throws, the time for the athletes to secure in the chair for the second set of three throws will be 2

minutes (F32-34 and F54-57) and 3 minutes (F31 and F51-53). There will be no warm-up throws allowed for the second set of three throws.

Note 3: While the responsibility for tying down rests with officials and volunteers, the Technical Delegate (or Referee) will issue specific interpretations at each competition that ensures athletes do not engage in time-wasting tactics.

ATFUSA exception: In U11 and U14 age groups, if time expires, the athlete will be offered one warm-up throw if none were taken within the time limit.

Rule 178.7 (Classes F31-34, F51-57)

If a chair tie-down device (not associated with the athlete's personal equipment) should break or fail during the execution of a throw, then the overseeing official should:

- (a) if the athlete does not foul, offer the athlete the option of re-taking that trial (i.e., if the athlete is happy with the distance and they haven't fouled, then the athlete has the option of counting the affected trial), or
- (b) if the athlete fouls, then the trial should not be counted and the athlete should be allowed to retake the affected trial.

Add: Rule 179: Secured (Seated) Throwing Technique, Lifting and Fouling

Rule 179 (Classes F31-34, F51-57)

1. In Secured Throw Events, all athletes (Sport Classes F31-34, F51-57) shall throw implements from a Throwing Frame in a seated position. The seated position is defined as follows:

a) The athlete must sit so that both legs are in contact with the seat surface from the back of the knee to the back of the buttock (Ischial tuberosity). For athletes with lower limb above and through the knee amputation, the residual length of the leg(s) must be in contact with the seat to the back of the buttock (ischial tuberosity).

b) This sitting position must be maintained throughout the throwing action until the implement has landed. Strapping across the upper thighs and or pelvis is encouraged.

Note: The intention of this rule is to minimize contribution of the legs to the athlete's performance.

2. An athlete shall commence his trial from a stationary seated position.

3. An athlete is not allowed to touch the strap(s) outside the vertical plane of the throwing circle.

4. It shall be a failure if an athlete moves from the seated position from the time the athlete takes the implement into the starting position of the trial until the implement has landed.

Note 1: It is not a failure if the back of the knee is only partly in contact with the seat during the throwing action until the implement has landed.

Note 2: If an athlete presents with anatomical limitation that prevents adherence to the above requirements, then an assessment will need to be made by WPA in advance of the event. WPA shall establish a process for such exception to be granted so that the athlete is throwing within the spirit of the rules.

(ATFUSA exception: For non-WPA licensed athletes the US national classifiers will document on an athlete's classification record that the athlete has such an exemption. This will allow the athlete to compete fairly.)

Rule 180: General Conditions (Field Events)

Rule 180.1 (Classes F31-34, F51-57)

In relation to secured throwing events, the second sentence of this rule should be deleted.

Rule 180.4(g) (Classes F31-34, F51-57)

Add: Note 2: In competitions other than Paralympic Games or World Championships, the Technical Delegate (or Referee) may decide, in co-operation with the Competition Organizers, to stage six (6) throws consecutively. In this case it is recommended that the competing order for six consecutive trials be in reverse ranking order recorded from the relevant list of valid performances achieved during a predetermined period. The Technical Delegate (or Referee) may, to guarantee a quick conduct of the event, also decide to stage six throws consecutively in a competition with more than eight (8) athletes. In that situation all athletes will have six (6) attempts. The Technical Delegate (or Referee) may not decide this in competitions where the first three rounds (preliminary rounds) are held in two or more flights.

Note 3: During secured throwing events, no reversal of throwing order will take place after the 3rd, 4th or 5th rounds, except:

(a) where the first three (3) rounds are held in two or more pools (flights). In such circumstances the final three (3) rounds will be held in reverse order of performance up to that point.

(b) in competitions where the Technical Delegate (or Referee) decides not to stage six (6) attempts consecutively (see previous Note).

Note 4: For secured throwing events, except where the first three rounds are held in two or more pools, an extra minute shall be added to the time limit between the third and fourth throws when six consecutive attempts are made.

COMMENT: In a practical sense, the Chief Judge or the Referee is in a position to allow additional time between throws if he determines that the athlete is not ready, or if the officials are not ready. For Seated Throwing the time clock should be initiated after the passing of the implement to the athlete and when the sector is ready and officials are out of the way. This may require some sort of audible instruction from the Chief Judge to the athlete. When the athlete finishes the third throw and the measurement is completed the time clock must be initiated for the one minute break. During the one minute break period the implement should not be provided to the athlete unless the athlete requests it. If the athlete asks for the implement before the one minute break has elapsed, then the time for the fourth throw shall commence immediately (i.e., in the moment the implement is handed to the athlete and when the sector is ready and officials are out of the way).

Note 5: In secured throwing events, the time allowed shall begin from the moment when the throwing implement has been presented to the athlete after the throwing frame has been fixed to the throwing circle and the athlete has been positioned and strapped on the frame.

Note 6: The following times normally should not be exceeded for each trial in WPA competitions:

Number of Athletes	High Jump	Other Events	Seated Throws
More than 3	1 min.	1 min.	1 min.
2 or 3	1.5 min.	1 min.	1 min.
1	3 min.	-	-
Consecutive Trials	2 min.	2 min.	1 min.

Add: Rule 180.4(i) (Classes F11-12)

During Jump Events, athletes in Class F11 can be accompanied onto the field of play by two (2) persons to:

- (1) act as a caller (i.e., instead of markers) to provide acoustic orientation during the approach run in the High Jump, Long Jump and Triple Jump, and/or
- (2) assist in positioning the athlete on the runway.

During throwing events, athletes in Class F11 can be accompanied onto the field of play by one (1) person only to act as caller and/or guide.

In Class F12, only one (1) person can accompany an athlete onto the field of play to act as caller and/or guide for all jumping and throwing events.

Note 1: the caller must stand in a position that does not hinder the officials. The caller must not run alongside or behind the athlete during a trial.

Note 2: Some Class 20, 35-38 and 42-47 athletes may require assistance in setting their runway markers prior to the competition. This would also apply to the javelin. The Technical Delegate (or Referee) will provide the appropriate athletes with a document on which to show their requirements.

Rule 180.12 (Classes F11-12)

Add: Rule 180.12(h): In field events where athletes receive assistance from callers or guides, the time allowed shall begin from the moment when the official responsible is satisfied that the athlete has completed the process of orientation. Should any athlete request verbal confirmation of the starting of the timing clock, an official shall give such confirmation.

Rule 180.12(i): If the athlete loses orientation and requires to be re-oriented, the clock shall be stopped and only restarted (to include any elapsed time already recorded) once orientation has again been completed.

Add: Rule 180.26 (Classes F42-44, F61-64)

Athletes in Classes F42-44 and F61-64 may use a running, hopping or standing start in jumping events.

Add: Rule 180.27

At all WPA recognized competitions, the Local Organizing Committee may use the WPA Combined Class Procedures and Tables to stage combined class events (i.e., including more than one Class in an event).

Note: For information regarding WPA Combined Class Procedures and Tables, please refer to the WPA website <http://www.paralympic.org/athletics/classification/rules-and-regulations>.

(ATFUSA exception for U11-U14 athletes, Adults and Masters athletes at Community, Level 2, Level 3 regional meets and U11-U14 Nationals: All seated throw athletes competing in wheelchairs may contest field competitions on a flat grassy area without a pad and do not require a toe board.)

Rule 182: High Jump

Rule 182.3 (Class F11-12)

Add: Note 2: Athletes in Class F11 may touch the bar as an aid to orientation before commencing the run up. If, on so doing, the athlete dislodges the bar, this will not count as an attempt.

Add: Note 3: Athletes in Class F12-13 may place an appropriate visual aid on the bar.

Add: Note 4: (Class F61-64) If the prosthesis is lost during the run-up then the athlete can try to adjust it and continue within the allowed time, or continue without the prosthesis; if in the process of jumping an athlete loses their prosthesis and the prosthesis does not clear the bar along with the athlete, it shall be counted as a failure and recorded as such.

Rule 184: Horizontal Jumps - General Rules

Rule 184.3 (Classes F11-12)

Add: Note: For athletes in Classes F11 and F12, the takeoff area shall consist of a rectangle 1.00m x 1.22m, as depicted in the diagram below, which must be prepared in such a way (by use of chalk, talcum powder, light sand, etc.) that the athlete leaves an impression on the area with his/her takeoff foot.

For F11-12: Recommended minimum width of the landing area is 3.50 m.

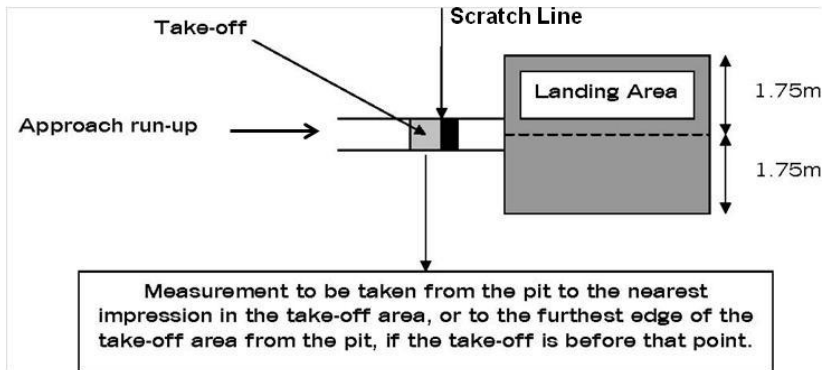

Rule 184.5 (Classes F11-12)

Add: Note 2: For purposes of safety, it is strongly recommended that the minimum width of the landing area be 3.5m. If this recommendation cannot be met, the Technical Delegate or Referee may require additional safety measures.

Rule 184.7 (Classes F11-12)

For athletes in Classes F11 and F12 replace after the first sentence of Rule 184.8 with: “All jumps shall be measured from the nearest impression left by the take-off foot to the nearest break in the landing area made by any part of the body of the competitor (including shoes and uniform). Where an athlete does not take off from the take-off area, but before it, measurement will be made to the edge of the takeoff area furthest from the pit.”

Add Rule 184.9 (Classes F61-64)

- (a) If the prosthesis is lost during the run-up, then the athlete can try to adjust it and continue within the allowed time, or continue without the prosthesis.
- (b) If the prosthetic device is lost during the process of jumping and the mark where the prosthetic device(s) lands is the closest mark to the take-off board in the landing area, then that is the mark that the trial will be measured from.
- (c) If the prosthetic device(s) land outside the landing area, it shall be counted as a failure (foul) and recorded as such.

ATFUSA exception to (c) above: If a prosthesis comes off during the attempt and lands outside the pit but further from the take-off board than the closest mark in the pit, the trial shall be marked from the closest mark in the landing area.

Rule 185: Long Jump

Rule 185.5(a) (Classes F61-64)

Modify: “It shall be counted as a failure or foul if any competitor:

- (a) While taking off, touches the ground beyond the take-off line with any part of his or her body or prosthetic device, whether running up without jumping or in the act of jumping; or”

Rule 186: Triple Jump

Rule 186.3 (Classes F46)

Replace with: “The take off board will normally be set at 9m for women and 11m for men.”

Rule 186.3 (Classes F11-13)

Replace with: “For International Competitions it is recommended that the take off board shall be the following distances: Class 11 minimum 9m; Classes F12 and F13 minimum 11m.”

Note: the exact distance from the board to pit shall be determined for each competition in consultation with the Technical Delegate or Referee.

Rule 187: Throwing Events - General Rules

Rule 187.1(b) (Classes F32-34, F51-57)

Add: Note: A stop-board is unnecessary for all athletes competing from throwing frames.

Rule 187.1(c) (Classes F31-34, F51-57)

Replace with: “Touches with any part of their body the top of the rim, any holding device outside the vertical plane of the edge of the Circle, or the ground outside the circle.”

Rule 187.3 and Rule 187.4 (Classes F31-34, F51-57)

Replace with: (a) The following shall be considered assistance and are therefore not allowed:

- i) The taping of two or more fingers together. If taping is used on the hands and fingers, it may be continuous provided that as a result no two or more fingers are taped together in such a way that the fingers cannot move individually. The taping should be shown to the Chief Judge before the event starts.
 - ii) The use of any device of any kind, including weights attached to the body, which in anyway provides assistance when making a trial;
 - iii) Use of gloves, except for athletes in Classes F31-33 and F51-53 that is not in contravention of Rule 187.3(b)(v);
 - iv) The spraying or spreading by an athlete of any substance in the circle or on his shoes nor the roughening of the surface of the circle.
- (b) The following shall not be considered assistance and are therefore allowed:
- i) The use by an athlete, in order to obtain a better grip, of a suitable substance on his hands only. Shot putters may use such substances on their neck;
 - ii) The placement by an athlete, in the Shot Put, Discus Throw and Club Throw, on the implement, chalk or a similar substance. All substance used shall be easily removable using a wet cloth and shall not leave any residue;
 - iii) The use of taping on the hands and fingers that is not in contravention of Rule 187.3(a)(i);
 - iv) The use of gloves that is not in contravention of Rule 187.3(a)(iii);
 - v) Athletes in Sport Classes F31-33 and F51-53 (i.e., quadriplegic athletes) may use strapping or a glove on their non-throwing hand and anchor/attach that hand to any part of the throwing frame within the vertical plane of the throwing circle.

Rule 187.5 (Classes F31-34, F51-57)

Add: Note: This rule shall be waived for competitors using a WPA approved holding device.

Rule 187.11

Add: Implements used at WPA recognized competitions must comply with World Athletics specifications. At WPA Paralympics, World or Regional events implements used must also hold a current valid World Athletics certificate of approval. Appendix I lists the implement weights to be used by:

- (a) "Open Age" athletes for each of the WPA classes at WPA recognized competitions.
- (b) "Under Age" athletes for each of the WPA during events for "Under Age" athletes with disability (AWDs) for the respective age groups recognized by WPA as defined in Rule 141.
- (c) for "Under Age" groups U14 and U11 recognized by ATFUSA.
- (d) for Masters groups M35, M50, M60 recognized by ATFUSA.

Rule 187.18 (Classes F32-34, F51-57)

Add: (a) WPA approved holding device must be used to conduct secured throwing events at WPA recognized competitions.

(b) At Paralympic Games, WPA World Athletics Championships and WPA Regional Championships the interior of the Throwing Circle should be constructed of concrete, asphalt or a similar non-slippery material.

(c) Where a portable WPA Approved Holding Devices is being used the surface must provide similar grip to a concrete throwing surface (e.g. coated in gritty paint OR covered in "gritty tape").

(d) Movable platforms can be used at the discretion of the Technical Delegate (or Referee). The platform does not have to be a full circle, but in these circumstances the front arc or semi circle must be designed to give the same effect of throwing from a circle, diameter 2.135m to 2.5m and not alter the angle of the sector.

Rule 187 (Classes F31-34, F51-57)

Add at end of Rule 187: Note 1: The rules for the club throw are the same as those of the seated discus (i.e., substitute "Club" for "Discus" throughout Rule 187).

Note 2: Discus Throw and Club Throw shall be conducted from a cage.

Note 3: The club shall be held at tits neck and/or head with one hand only. It may be thrown either from a position facing the landing sector or from a position facing backward and throwing overhead.

Rule 188: Putting the Shot

Rule 188.2 (Classes F32-34, F52-57)

Add: Note 2: For Classes F33-34 and F52-57, from start to finish, the movement shall be a straight, continuous putting action.

Add: Note 3: For Class F32, lateral movement of the shot away from the chin or neck during the putting action is allowed.

Rule 189.1: Throwing the Discus

ATFUSA exception for U11-U14: Note: The discus shall not be released from an overhand throw or from a position that begins at or near the midline of the body [i.e., a Frisbee throw].

Rule 193.1(c): Throwing the Javelin

(ATFUSA exception for U11-U14: For age classes U11 and U14, a throw that lands flat or tail first will not be called a foul throw but will be marked at the rear of the grip (if flat) and at the point where the tail hits (if tail first). For all older age groups a tip-first landing is required.)

SECTION VIII - ROAD RACES

Rule 240: Road Races

Add: Rule 241.2 (b) (Classes T11-13)

Note 3: Athletes and their guide-runners can receive assistance at the refreshment stations. Organizers must ensure that officials are aware of the specific problems of safety presented in providing drinks to blind and partially sighted athletes, and that adequate training is given to all assistants involved.

Rule 241.2(d) (Classes T32-34, T51-54)

Add: Note: Wheelchair athletes may carry their own refreshments.

Rule 241.2(f) (Classes T11-13)

Modify to read “An athlete and/or guide-runner who collects refreshment from a place other than a refreshment station is liable to disqualification by the Referee.

Rule 242.4 (Classes T11-13, T35-38, T42-47)

Add: Note 1: In road races, ambulant athletes from a range of Classes can start together, but the finishing order will be determined for each Class.

Rule 242.4 (Sport Classes T32-34 & T51-54)

Add: Note 1: In road races, wheelchair athletes from a range of Classes will start according to the decision of the Technical Delegate or Referee for the event, but the finishing order will be determined for each Class.

Note 2: Seeding for wheelchair road races should be by Class, Seed Time and Gender (i.e., T54/34 Males should be seeded in the front row/s, then T54/34 Females, then T52/33/51 Males and then the T52/33/51 Females). The start of each Class event/division should be separated by intervals of 30 seconds to 1 minute. The seeding grid for each Class event/division should position the #1 seeded athlete at the center position in the front row of the grid with #2 and #3 placed on their right and left, #4 and #5 on their right and left and so on.

Rule 243.3 (Classes “All competing Classes”)

Add: The Organizing Committee shall provide numbered bibs that distinguish between athletes of each Class.

Add: Rule 243.5 (Classes T32-34, T51-54)

Drafting behind an athlete from another Class or Gender is prohibited.

Note 1: Drafting is defined as seeking a performance advantage by following another athlete within a distance of less than 5m for 400m.

Note 2: This rule does not apply to races over 800m for T53 and T54, as they are considered one class.

Add: Rule 243.6 (Classes T11-12)

During road races athletes in Classes T11-12 are allowed to use a maximum of four (4) guide-runners. Any interchanges must take place without any hindrance to other athletes, and must take place at either the 10km, 20km or 30km marks.

The intention to interchange guide-runners must be notified in advance to the Referee and Technical Delegate. The technical officials will determine the conditions of the interchange and will communicate these in advance to the athletes and their guide-runners.

Note: It is strongly recommended that organizers ensure that the race takes place in its entirety in good daylight conditions.

Additional exceptions for ATFUSA U11-U14, regarding events and records:

- The softball throw has been eliminated for all but the U14 and U11 age groups.
- The athletes across all age categories eligible to throw the club are F31, F32 and F51 only.
- Terminology for records will consistently be stated as U11 or U14 National Record, National Record, Americas Record and World Record.
- U11 and U14 National Records must be verified with a steel tape by two USATF or higher certified officials. In the throwing events, the implement does not need to be impounded immediately, but must be reweighed post-competition.
- National, Americas and World Records must be verified with a steel tape by the Field Referee or his/her designee and two certified officials. In throwing events the implement must be recertified.
- U11 and U14 National Records can be broken only at Adaptive Sports USA U11 and U14 Nationals or at Level 3 meets, or at a WPA sanctioned/approved event, and are to be submitted on ATFUSA forms to the ATFUSA national office via formal application within 60 days of the competition.

Adaptive Track and Field Meet Guidelines for Para (Unified) Athletes in High School Competitions

Description:

For use in high school meets *where individual WPA athletic classification rules are not followed*. (Guidelines for USATF Youth competition are in the following section.)

Rationale:

Add two (2) adapted divisions (Wheelchair and Ambulatory), for each gender, to the current high school competitions, which will allow eligible athletes with disabilities to participate *at meets not following individual classification WPA Rules*.

Adaptive Track and Field Division.

- (1) Boys Adapted Wheelchair (Seated) Division
- (2) Boys Adapted Ambulatory (Standing) Division
- (3) Girls Adapted Wheelchair (Seated) Division
- (4) Girls Adapted Ambulatory (Standing) Division

An athlete cannot compete in an able-bodied and adapted Division at the same meet.

Adapted Track and Field Division Eligibility.

- (1) All high school athletes with a permanent, physical disability may be eligible to participate.
- (2) Each athlete's physical eligibility must be verified by their school. Athletes who participate must meet all state high school federation meet eligibility requirements.

Adapted Track and Field Division Events.

Athletes will have the opportunity to compete at a minimum in the following non-WPA rule Open division events by gender (other events may be added based on the meet and the athletes competing):

- (1) Ambulatory 200 meter race,
- (2) Wheelchair 200 meter race,
- (3) Ambulatory 800 meter race,
- (4) Wheelchair 800 meter race,
- (5) Ambulatory Shot Put,
- (6) Wheelchair Shot Put.

In some states the wheelchair shot put may be divided into two (2) wheelchair classifications based on the Athlete's level of disability. (check with your local high school federation.)

Class 1: Will be for wheelchair athletes with any disability of the lower extremities.

Class 2: Will be for wheelchair athletes with disabilities that affect the lower and the upper extremities.

- (7) A meet's order of events shall be determined by meet management.
- (8) All adapted track and field participants shall be required to compete on the same day of the meet as their other division competitors.
- (9) In addition to the above minimal events, the following events also may be contested (check with your local USATF Association or your state high school federation for a list of locally approved events): Ambulatory 100 meter race, Wheelchair 100 meter race, Ambulatory 400 meter race, Wheelchair 400 meter race, Ambulatory 1500 meter race, Wheelchair 1500 meter race, Ambulatory Discus Throw, Wheelchair Discus Throw, Ambulatory Javelin Throw, Wheelchair Javelin Throw, Ambulatory Long Jump, Ambulatory Triple Jump, Ambulatory High Jump.

Scoring and Awards.

An adapted athlete will compete in their individual division by gender. Ambulatory para athletes can be included in the same heats, flights and finals as able-bodied athletes; however, placing, awards and points will be separated for each group.

Event Rules

A. Wheelchair 200m and Wheelchair 800m Races:

(Other Track events may be contested if approved by the Meet Director)

The track events shall follow all NFHS rules with the following modifications:

1. Racing Track chair Specifications. (Normal wheelchairs are acceptable if approved by the meet director):
 - a. The track chair shall have two rear wheels and one front wheel.
 - b. The track chair frame shall not extend in front of the center of the front wheel hub.
 - c. The track chair may have no mechanical gears or levers that would propel the chair.
 - d. The steering must be hand operated. NO electronic steering is allowed.
 - e. No part of the track chair or frame may protrude to the rear past the furthest point of the rear wheel.
 - f. Athlete's lower limbs must be secured to the track chair. Any touch of the ground by the lower limb results in disqualification from the event.
 - g. Competitors are responsible for the proper functioning of the track chair. No event shall be delayed for equipment failure prior to event.
2. Wheels:
 - a. The maximum diameter of the rear wheel and inflated tire is 70 cm.
 - b. The maximum diameter of the front wheel and inflated tire is 50 cm.
 - c. Each rear wheel may have one hand rim.
3. Helmet and Gloves:
 - a. All competitors in track events must wear a CPSC certified helmet (Bike/Skate)
 - b. All competitors must start each event using gloves.
4. Athletes may only propel the chair forward by pushing on the wheels or hand rims.
5. The Start: The center of the front axle (axle plane) may not extend over the starting line. Wheelchair competitors should race in their own heats.
6. The Finish: The finish of the race occurs when the center of the front axles (axle plane) crosses the finish line.
7. Wheeling in Lane: In the 200m or any in-lane race competitors must stay in their designated lane. Touching or crossing the inner lane line in the curve for more than 10 consecutive feet results in disqualification. Crossing a lane line (inner or outer on the curve or straight) for any distance and impeding another competitor results in disqualification.
8. Passing or changing lanes: In the 800m or any race run out of lane, competitors must have full clearance of another athlete's front wheel in order to pass or move into another lane. Failure to pass or change lanes correctly will result in disqualification.
9. The start for the 800m shall be started in lanes. Athletes shall start from the one turn stagger start lines and remain in-lane until the rear wheels of the racing wheelchair or regular wheelchair cross the 800m break line. This line shall be marked by tall cones on either side of the track.
10. Obstruction:

- a. Athletes may not intentionally touch or obstruct another competitor during an event.
- b. Any obstruction of another athlete may result in disqualification.

B. Wheelchair (Seated) Shot Put:

(Other field events may be contested if approved by the Meet Director)

The Wheelchair (Seated) Shot Put shall follow all NFHS rules with the following modifications (Note: the Ambulatory Shot Put shall follow normal NFHS rules for the Shot Put):

1. All competitors must put the shot from a “chair “(manual wheelchair, throwing frame, power wheelchair). Scooters and “standing chairs” will not be allowed.
2. The uppermost part of the cushion/seat on any chair may not exceed 75 cm (29.5inches) above the ground. The cushion/seat must be square or rectangular in shape, with each side at least 30cm in length.
3. The chair will be considered an extension of the athletes’ body. For example: no part of the chair may extend beyond the vertical plane of the throwing circle.
4. The chair may have
 - a. A solid vertical, non-bending, holding bar.
 - b. A front, sides or backrest for the purpose of stability.
 - c. Non-elastic strap(s) holding the athlete’s body and/or feet to the chair.
 - d. Straps connected to hold-down stakes in or out of the throwing ring.
5. Some state high school federations may require that there be two (2) classifications for both boys and girls.
 - a. If that is the case in your state high school federation, the classifications may be Class 1 and Class 2.
 - Class 1 will be for athletes with any disability of the lower extremities (spinal cord injury, amputation, spina bifida, cerebral palsy, orthopedic injuries), for example: severe, permanent injuries in the knee, ankle, and hips.
 - Class 2 will be for athletes with disability that affect lower and upper extremities (cervical spinal, cerebral palsy, muscular dystrophy, traumatic brain injury.)
 - Class 2 athletes are eligible to compete in Class 1. However, if they choose to compete in Class 1, they cannot compete in Class 2 in another event in that meet.
 - b. Boy’s class 1 will use a: 8.81 lb./4.0 kg. shot, (1 kg discus)*, (600 gr javelin)*
 - c. Boy’s class 2 will use a: 6 lb. shot, (0.75 kg discus)*, (400 gr javelin)* (Note: If only one class is being used for the wheelchair shot put, the boys will use the implement weights listed here for Class 1.)
 - d. Girl’s class 1 and 2 will use a: 6 lb. shot., (0.75 kg discus)* , (400 gr javelin)*

* For the newly added discus and javelin events, if contested, check with your state high school federation office for high school implement weights, since each state federation may decide what weights to use.
6. A coach may assist the athlete entering and leaving the circle.
7. The Wheelchair (Seated) Division Shot Put:
 - a. All athletes must compete from a chair or throwing frame in a fully seated position.
 - b. The athlete must sit so that both legs are in contact with the seat surface from the back of the knee to the back of the buttock (Ischial tuberosity)

- c. This sitting position must be maintained throughout the throwing action until the implement has landed. Strapping across the upper thighs and or pelvis is encouraged.
- d. An athlete shall commence his trial from a stationary seated position.
- e. An athlete is not allowed to touch the strap(s) outside the vertical plane of the throwing circle.
- f. It shall be a failure if an athlete fails to maintain the required contact with the seat surface from the time the athlete takes the implement into the starting position of the trial until the implement has landed.
- g. It is not a failure if only part of the back of the knee is in contact with the seat during the throwing action until the implement has landed.
- h. Once the athlete's chair has been tied down in throwing position, the athlete will be permitted all six attempts consecutively, with up to a 1 minute break between attempts 3 and 4 to allow the athlete to rest and / or to adjust strapping.
- i. Seated (wheelchair) shot putters may throw from the same circle as their able-bodied peers, but may compete before or after their flights; or they may compete in a separate circle or arc with sector lines in a separate location.

Note: The intention of this rule is to minimize contribution of the legs to the athlete's performance.

Adaptive Track and Field Meet Guidelines for Para Athletes in High School Competitions

Description:

For use in high school meets *where individual WPA athletic classification rules are not followed*. (Guidelines for USATF Youth competition are in the following section.)

Rationale:

Add two (2) adapted divisions (Wheelchair and Ambulatory), for each gender, to the current high school competitions, which will allow eligible athletes with disabilities to participate *at meets not following individual classification WPA Rules*.

Adaptive Track and Field Division.

- (1) Boys Adapted Wheelchair (Seated) Division
- (2) Boys Adapted Ambulatory (Standing) Division
- (3) Girls Adapted Wheelchair (Seated) Division
- (4) Girls Adapted Ambulatory (Standing) Division

An athlete cannot compete in an able-bodied and adapted Division at the same meet.

Adapted Track and Field Division Eligibility.

- (1) All high school athletes with a permanent, physical disability may be eligible to participate.
- (2) Each athlete's physical eligibility must be verified by their school. Athletes who participate must meet all state high school federation meet eligibility requirements.

Adapted Track and Field Division Events.

Athletes will have the opportunity to compete at a minimum in the following non-WPA rule Open division events by gender (other events may be added based on the meet and the athletes competing):

- (1) Ambulatory 200 meter race,
- (2) Wheelchair 200 meter race,
- (3) Ambulatory 800 meter race,
- (4) Wheelchair 800 meter race,
- (5) Ambulatory Shot Put,
- (6) Wheelchair Shot Put.

In some states the wheelchair shot put may be divided into two (2) wheelchair classifications based on the Athlete's level of disability. (check with your local high school federation.)

Class 1: Will be for wheelchair athletes with any disability of the lower extremities.

Class 2: Will be for wheelchair athletes with disabilities that affect the lower and the upper extremities.

- (7) A meet's order of events shall be determined by meet management.
- (8) All adapted track and field participants shall be required to compete on the same day of the meet as their other division competitors.
- (9) In addition to the above minimal events, the following events also may be contested (check with your local USATF Association or your state high school federation for a list of locally approved events): Ambulatory 100 meter race, Wheelchair 100 meter race, Ambulatory 400 meter race, Wheelchair 400 meter race, Ambulatory 1500 meter race, Wheelchair 1500 meter race, Ambulatory Discus Throw, Wheelchair Discus Throw, Ambulatory Javelin Throw, Wheelchair Javelin Throw, Ambulatory Long Jump, Ambulatory Triple Jump, Ambulatory High Jump.

Scoring and Awards.

An adapted athlete will compete in their individual division by gender. Ambulatory para athletes can be included in the same heats, flights and finals as able-bodied athletes; however, placing, awards and points will be separated for each group.

Event Rules

A. Wheelchair 200m and Wheelchair 800m Races:

(Other Track events may be contested if approved by the Meet Director)

The track events shall follow all NFHS rules with the following modifications:

1. Racing Track chair Specifications. (Normal wheelchairs are acceptable if approved by the meet director):
 - a. The track chair shall have two rear wheels and one front wheel.
 - b. The track chair frame shall not extend in front of the center of the front wheel hub.
 - c. The track chair may have no mechanical gears or levers that would propel the chair.
 - d. The steering must be hand operated. NO electronic steering is allowed.
 - e. No part of the track chair or frame may protrude to the rear past the furthest point of the rear wheel.
 - f. Athlete's lower limbs must be secured to the track chair. Any touch of the ground by the lower limb results in disqualification from the event.
 - g. Competitors are responsible for the proper functioning of the track chair. No event shall be delayed for equipment failure prior to event.
2. Wheels:
 - a. The maximum diameter of the rear wheel and inflated tire is 70 cm.
 - b. The maximum diameter of the front wheel and inflated tire is 50 cm.
 - c. Each rear wheel may have one hand rim.
3. Helmet and Gloves:
 - a. All competitors in track events must wear a CPSC certified helmet (Bike/Skate)
 - b. All competitors must start each event using gloves.
4. Athletes may only propel the chair forward by pushing on the wheels or hand rims.
5. The Start: The center of the front axle (axle plane) may not extend over the start line. Wheelchair competitors should race in their own heats.
6. The Finish: The finish of the race occurs when the center of the front axles (axle plane) crosses the finish line.
7. Wheeling in Lane: In the 200m or any in-lane race competitors must stay in their designated lane. Touching or crossing the inner lane line in the curve for more than 10 consecutive feet results in disqualification. Crossing a lane line (inner or outer on the curve or straight) for any distance and impeding another competitor results in disqualification.
8. Passing or changing lanes: In the 800m or any race run out of lane, competitors must have full clearance of another athlete's front wheel in order to pass or move into another lane. Failure to pass or change lanes correctly will result in disqualification.
9. The start for the 800m shall be started in lanes. Athletes shall start from the one turn stagger start lines and remain in-lane until the rear wheels of the racing wheelchair or regular wheelchair cross the 800m break line. This line shall be marked by tall cones on either side of the track.
10. Obstruction:

- a. Athletes may not intentionally touch or obstruct another competitor during an event.
- b. Any obstruction of another athlete may result in disqualification.

B. Wheelchair (Seated) Shot Put:

(Other field events may be contested if approved by the Meet Director)

The Wheelchair (Seated) Shot Put shall follow all NFHS rules with the following modifications (Note: the Ambulatory Shot Put shall follow normal NFHS rules for the Shot Put):

1. All competitors must put the shot from a “chair” (manual wheelchair, throwing frame, power wheelchair). Scooters and “standing chairs” will not be allowed.
2. The uppermost part of the cushion/seat on any chair may not exceed 75 cm (29.5 inches) above the ground. The cushion/seat must be square or rectangular in shape, with each side at least 30 cm in length.
3. The chair will be considered an extension of the athletes’ body. For example: no part of the chair may extend beyond the vertical plane of the throwing circle.
4. The chair may have
 - a. A solid vertical, non-bending, holding bar.
 - b. A front, sides or backrest for the purpose of stability.
 - c. Non-elastic strap(s) holding the athlete’s body and/or feet to the chair.
 - d. Straps connected to hold-down stakes in or out of the throwing ring.
5. Some state high school federations may require that there be two (2) classifications for both boys and girls.
 - a. If that is the case in your state high school federation, the classifications may be Class 1 and Class 2.
 - Class 1 will be for athletes with any disability of the lower extremities (spinal cord injury, amputation, spina bifida, cerebral palsy, orthopedic injuries), for example: severe, permanent injuries in the knee, ankle, and hips.
 - Class 2 will be for athletes with disability that affect lower and upper extremities (cervical spinal, cerebral palsy, muscular dystrophy, traumatic brain injury.)
 - Class 2 athletes are eligible to compete in Class 1. However, if they choose to compete in Class 1, they cannot compete in Class 2 in another event in that meet.
 - b. Boy’s class 1 will use a: 8.81 lb./4.0 kg. shot, (1 kg discus)*, (600 gr javelin)*
 - c. Boy’s class 2 will use a: 6 lb. shot, (0.75 kg discus)*, (400 gr javelin)* (Note: If only one class is being used for the wheelchair shot put, the boys will use the implement weights listed here for Class 1.)
 - d. Girl’s class 1 and 2 will use a: 6 lb. shot., (0.75 kg discus)*, (400 gr javelin)*

* For the newly added discus and javelin events, if contested, check with your state high school federation office for high school implement weights, since each state federation may decide what weights to use.
6. A coach may assist the athlete entering and leaving the circle.
7. The Wheelchair (Seated) Division Shot Put:
 - a. All athletes must compete from a chair or throwing frame in a fully seated position.
 - b. The athlete must sit so that both legs are in contact with the seat surface from the back of the knee to the back of the buttock (Ischial tuberosity)

- c. This sitting position must be maintained throughout the throwing action until the implement has landed. Strapping across the upper thighs and or pelvis is encouraged.
- d. An athlete shall commence his trial from a stationary seated position.
- e. An athlete is not allowed to touch the strap(s) outside the vertical plane of the throwing circle.
- f. It shall be a failure if an athlete fails to maintain the required contact with the seat surface from the time the athlete takes the implement into the starting position of the trial until the implement has landed.
- g. It is not a failure if only part of the back of the knee is in contact with the seat during the throwing action until the implement has landed.
- h. Once the athlete's chair has been tied down in throwing position, the athlete will be permitted all six attempts consecutively, with up to a 1 minute break between attempts 3 and 4 to allow the athlete to rest and / or to adjust strapping.
- i. Seated (wheelchair) shot putters may throw from the same circle as their able-bodied peers, but may compete before or after their flights; or they may compete in a separate circle or arc with sector lines in a separate location.

Note: The intention of this rule is to minimize contribution of the legs to the athlete's performance.

APPENDIX I

Throwing Events – WPA Athletics Implement Weights

Events for the visually impaired athletes (F11-13) & athletes with learning difficulties (F20)

Age Group	Classes	Discus Male	Discus Female	Javelin Male	Javelin Female	Shot Put Male	Shot Put Female
Open / U23*	F11-13 & F20	2.00kg	1.00kg	800gr	600gr	7.26kg	4.00kg
U/20	F11-13 & F20	2.00kg	1.00kg	800gr	600gr	7.26kg	4.00kg
U/17	F11-13 & F20	1.50kg	1.00kg	700gr	500gr	5.00kg	3.00kg
U/14*	F11-13 & F20	0.75kg	0.75kg	400gr	400gr	3.00kg	3.00kg
U/11*	F11-13 & F20	0.75kg	0.75kg	300gr	300gr	2.00kg	2.00kg
M/F35*	F11-13	1.75kg	1.00kg	800g	600gr	6.00kg	4.00kg
M/F50*	F11-13	1.50kg	750gr	700g	500gr	5.00kg	3.00kg
M/F60*	F11-13	1.00kg	750gr	600g	400gr	4.00kg	2.00kg
M/F35*	F20	2.00kg	1.00kg	800g	600gr	6.00kg	4.00kg
M/F50*	F20	1.75kg	750gr	700g	500gr	5.00kg	3.00kg
M/F60*	F20	1.50kg	750gr	600g	400gr	4.00kg	2.00kg

* Note: Not included in WPA tables.

Events for athletes with Hypertonia, Ataxia, and/or Athetosis (F31-38)

Age Group	Classes	Discus Male	Discus Female	Javelin Male	Javelin Female	Shot Put Male	Shot Put Female	Club Male & Female
Open, And U23* U/20	F31	NE	NE	NE	NE	NE	NE	397gr
	F32	1.00kg	1.00kg	NE	NE	2.00kg	2.00kg	397gr
	F33	1.00kg	1.00kg	600gr	600gr	3.00kg	3.00kg	NE
	F34	1.00kg	1.00kg	600gr	600gr	4.00kg	3.00kg	NE
	F35	1.00kg	1.00kg	600gr	600gr	4.00kg	3.00kg	NE
	F36	1.00kg	1.00kg	600gr	600gr	4.00kg	3.00kg	NE
	F37	1.00kg	1.00kg	600gr	600gr	5.00kg	3.00kg	NE

	F38	1.50k g	1.00kg	800gr	600gr	5.00k g	3.00kg	NE
U/17	F31	NE	NE	NE	NE	NE	NE	397gr
	F32	750gr	750gr	NE	NE	1.00k g	1.00kg	397gr
	F33	750gr	750gr	500gr	500gr	2.00k g	2.00kg	NE
	F34	750gr	750gr	500gr	500gr	3.00k g	2.00kg	NE
	F35	750gr	750gr	500gr	500gr	3.00k g	2.00kg	NE
	F36	750gr	750gr	500gr	500gr	3.00k g	2.00kg	NE
	F37	750gr	750gr	500gr	500gr	4.00k g	2.00kg	NE
	F38	1.00k g	750gr	600gr	500gr	4.00k g	2.00kg	NE
U/14*	F31	750gr	750gr	NE	NE	NE	NE	397gr
	F32	750gr	750gr	NE	NE	1.00k g	1.00kg	397gr
	F33	750gr	750gr	400gr	400gr	2.00k g	2.00kg	NE
	F34	750gr	750gr	400gr	400gr	2.00k g	2.00kg	NE
	F35	750gr	750gr	400gr	400gr	2.00k g	2.00kg	NE
	F36	750gr	750gr	400gr	400gr	2.00k g	2.00kg	NE
	F37	750gr	750gr	400gr	400gr	3.00k g	2.00kg	NE
	F38	750gr	750gr	400gr	400gr	3.00k g	2.00kg	NE
U/11*	F31	750gr	750gr	NE	NE	NE	NE	397gr
	F32	750gr	750gr	NE	NE	1.00k g	1.00kg	397gr
	F33	750gr	750gr	300gr	300gr	1.00k g	1.00kg	NE
	F34	750gr	750gr	300gr	300gr	1.00k g	1.00kg	NE
	F35	750gr	750gr	300gr	300gr	1.00k g	1.00kg	NE
	F36	750gr	750gr	300gr	300gr	1.00k g	1.00kg	NE
	F37	750gr	750gr	300gr	300gr	2.00k g	2.00kg	NE
	F38	750gr	750gr	300gr	300gr	2.00k g	2.00kg	NE
M/F35 *	F31	NE	NE	NE	NE	NE	NE	397gr
	F32	1.00k g	1.00kg	NE	NE	2.00k g	2.00kg	397gr

	F33	1.00k g	1.00kg	600gr	600gr	3.00k g	3.00kg	NE
	F34	1.00k g	1.00kg	600gr	600gr	4.00k g	3.00kg	NE
	F35	1.00k g	1.00kg	600gr	600gr	4.00k g	3.00kg	NE
	F36	1.00k g	1.00kg	600gr	600gr	4.00k g	3.00kg	NE
	F37	1.00k g	1.00kg	600gr	600gr	5.00k g	3.00kg	NE
	F38	1.50k g	1.00kg	800gr	600gr	5.00k g	3.00kg	NE
M/F50 *	F31	NE	NE	NE	NE	NE	NE	397gr
	F32	750gr	750gr	NE	NE	1.00k g	1.00kg	397gr
	F33	750gr	750gr	500gr	500gr	2.00k g	2.00kg	NE
	F34	750gr	750gr	500gr	500gr	3.00k g	2.00kg	NE
	F35	750gr	750gr	500gr	500gr	3.00k g	2.00kg	NE
	F36	750gr	750gr	500gr	500gr	3.00k g	2.00kg	NE
	F37	750gr	750gr	500gr	500gr	4.00k g	2.00kg	NE
	F38	1.00k g	750gr	700gr	500gr	4.00k g	2.00kg	NE
M/F60 *	F31	NE	NE	NE	NE	NE	NE	397gr
	F32	750gr	750gr	NE	NE	1.00k g	1.00kg	397gr
	F33	750gr	750gr	400gr	400gr	1.00k g	1.00kg	NE
	F34	750gr	750gr	400gr	400gr	2.00k g	1.00kg	NE
	F35	750gr	750gr	400gr	400gr	2.00k g	1.00kg	NE
	F36	750gr	750gr	400gr	400gr	2.00k g	1.00kg	NE
	F37	750gr	750gr	400gr	400gr	3.00k g	1.00kg	NE
	F38	750gr	750gr	600gr	400gr	3.00k g	1.00kg	NE

* Note: Not included in WPA tables.

Events for Dwarfs and Athletes with Lower Limb Impairment (not using prostheses) and Arm Amputees (F40-46)

Age Group	Classes	Discus Male	Discus Female	Javelin Male	Javelin Female	Shot Put Male	Shot Put Female
Open, U23* & U/20	F40, F41	1.00kg	750gr	600gr	400gr	4.00kg	3.00kg
	F42	1.50kg	1.00kg	800gr	600gr	6.00kg	4.00kg
	F43, F44	1.50kg	1.00kg	800gr	600gr	6.00kg	4.00kg
	F45, F46	1.50kg	1.00kg	800gr	600gr	6.00kg	4.00kg
U/17	F41, F40	1.00kg	750gr	500gr	400gr	3.00kg	2.00kg
	F42	1.00kg	1.00kg	700gr	500gr	5.00kg	3.00kg
	F44, F43	1.00kg	1.00kg	700gr	500gr	5.00kg	3.00kg
	F46, F45	1.00kg	1.00kg	700gr	500gr	5.00kg	3.00kg
U/14*	F40	0.750gr	750gr	400gr	400gr	2.00kg	2.00kg
	F42, F41	0.750gr	750gr	400gr	400gr	3.00kg	2.00kg
	F44, F43	0.750gr	750gr	400gr	400gr	3.00kg	2.00kg
	F46, F45	0.750gr	750gr	400gr	400gr	3.00kg	2.00kg
U/11*	F40	0.750gr	750gr	300gr	300gr	2.00kg	2.00kg
	F42, F41	0.750gr	750gr	300gr	300gr	2.00kg	2.00kg
	F44, F43	0.750gr	750gr	300gr	300gr	2.00kg	2.00kg
	F46, F45	0.750gr	750gr	300gr	300gr	2.00kg	2.00kg
M/F35*	F41, F40	1.00kg	750gr	600gr	400gr	4.00kg	3.00kg
	F42- F44	1.50kg	1.00kg	800gr	600gr	6.00kg	4.00kg
	F45	1.50kg	1.00kg	800gr	600gr	4.00kg	4.00kg
	F46	1.50kg	1.00kg	800gr	600gr	6.00kg	4.00kg
M/F50*	F41, F40	750gr	750gr	500gr	400gr	3.00kg	2.00kg
	F42- F44	1.00kg	750gr	700gr	500gr	5.00kg	3.00kg
	F45	1.00kg	750gr	700gr	500gr	3.00kg	3.00kg
	F46	1.00kg	750gr	700gr	500gr	5.00kg	3.00kg
M/F60*	F41, F40	750gr	750gr	400gr	400gr	2.00kg	1.00kg

	F42-F44	750gr	750gr	600gr	400gr	4.00kg	2.00kg
	F45	750gr	750gr	600gr	400gr	2.00kg	2.00kg
	F46	750gr	750gr	600gr	400gr	4.00kg	2.00kg

* Note: Not included in WPA tables.

Events for seated or secured throwers (F51-F57)

Age Group	Classes	Discus Male	Discus Female	Javelin Male	Javelin Female	Shot Put Male	Shot Put Female	Club Male & Female
Open, U23* & U/20	F51	1.00kg	1.00kg	NE	NE	NE	NE	397gr
	F52	1.00kg	1.00kg	600gr	600gr	2.00kg	2.00kg	NE
	F53	1.00kg	1.00kg	600gr	600gr	3.00kg	3.00kg	NE
	F54	1.00kg	1.00kg	600gr	600gr	4.00kg	3.00kg	NE
	F55	1.00kg	1.00kg	600gr	600gr	4.00kg	3.00kg	NE
	F56	1.00kg	1.00kg	600gr	600gr	4.00kg	3.00kg	NE
	F57	1.00kg	1.00kg	600gr	600gr	4.00kg	3.00kg	NE
U/17	F51	750gr	750gr	NE	NE	NE	NE	397gr
	F52	750gr	750gr	500gr	500gr	2.00kg	2.00kg	NE
	F53	750gr	750gr	500gr	500gr	2.00kg	2.00kg	NE
	F54	750gr	750gr	500gr	500gr	3.00kg	2.00kg	NE
	F55	750gr	750gr	500gr	500gr	3.00kg	2.00kg	NE
	F56	750gr	750gr	500gr	500gr	3.00kg	2.00kg	NE
	F57	1.00kg	750gr	500gr	500gr	3.00kg	2.00kg	NE
U/14*	F51	750gr	750gr	NE	NE	NE	NE	397gr*
	F52	750gr	750gr	400gr	400gr	2.00kg	2.00kg	NE
	F53	750gr	750gr	400gr	400gr	2.00kg	2.00kg	NE
	F54	750gr	750gr	400gr	400gr	2.00kg	2.00kg	NE
	F55	750gr	750gr	400gr	400gr	2.00kg	2.00kg	NE

	F56	750gr	750gr	400gr	400gr	2.00k g	2.00kg	NE
	F57	750gr	750gr	400gr	400gr	2.00k g	2.00kg	NE
U/11*	F51	750gr	750gr	NE	NE	NE	NE	397gr* *
	F52	750gr	750gr	300gr	300gr	2.00k g	2.00kg	NE
	F53	750gr	750gr	300gr	300gr	2.00k g	2.00kg	NE
	F54	750gr	750gr	300gr	300gr	2.00k g	2.00kg	NE
	F55	750gr	750gr	300gr	300gr	2.00k g	2.00kg	NE
	F56	750gr	750gr	300gr	300gr	2.00k g	2.00kg	NE
	F57	750gr	750gr	300gr	300gr	2.00k g	2.00kg	NE
M/F35 *	F51	1.00k g	1.00kg	NE	NE	NE	NE	397gr
	F52	1.00k g	1.00kg	600gr	600gr	2.00k g	2.00kg	NE
	F53	1.00k g	1.00kg	600gr	600gr	3.00k g	3.00kg	NE
	F54	1.00k g	1.00kg	600gr	600gr	4.00k g	3.00kg	NE
	F55	1.00k g	1.00kg	600gr	600gr	4.00k g	3.00kg	NE
	F56	1.00k g	1.00kg	600gr	600gr	4.00k g	3.00kg	NE
	F57	1.00k g	1.00kg	600gr	600gr	4.00k g	3.00kg	NE
M/F50 *	F51	750gr	750gr	NE	NE	NE	NE	397gr
	F52	750gr	750gr	500gr	500gr	1.00k g	1.00kg	NE
	F53	750gr	750gr	500gr	500gr	2.00k g	2.00kg	NE
	F54	750gr	750gr	500gr	500gr	3.00k g	2.00kg	NE
	F55	750gr	750gr	500gr	500gr	3.00k g	2.00kg	NE
	F56	750gr	750gr	500gr	500gr	3.00k g	2.00kg	NE
	F57	750gr	750gr	500gr	500gr	3.00k g	2.00kg	NE
M/F60 *	F51	750gr	750gr	NE	NE	NE	NE	397gr
	F52	750gr	750gr	400gr	400gr	1.00k g	1.00kg	NE
	F53	750gr	750gr	400gr	400gr	1.00k g	1.00kg	NE

	F54	750gr	750gr	400gr	400gr	2.00k g	1.00kg	NE
	F55	750gr	750gr	400gr	400gr	2.00k g	1.00kg	NE
	F56	750gr	750gr	400gr	400gr	2.00k g	1.00kg	NE
	F57	750gr	750gr	400gr	400gr	2.00k g	1.00kg	NE

* Note: Not included in WPA tables.

** Softball 11” or 12”

Events for Leg Amputees (with prostheses) (F61-64)

Age Group	Classes	Discus Male	Discus Female	Javelin Male	Javelin Female	Shot Put Male	Shot Put Female
Open, U23* & U/20	F61, F63	1.50kg	1.00kg	800gr	600gr	6.00kg	4.00kg
	F62, F64	1.50kg	1.00kg	800gr	600gr	6.00kg	4.00kg
U/17	F61, F63	1.00kg	1.00kg	700gr	500gr	5.00kg	3.00kg
	F62, F64	1.00kg	1.00kg	700gr	500gr	5.00kg	3.00kg
U/14*	F61, F63	750gr	750gr	400gr	400gr	3.00kg	2.00kg
	F62, F64	1.00kg	1.00kg	700gr	500gr	5.00kg	3.00kg
U/11*	F61, F63	750gr	750gr	300gr	300gr	2.00kg	2.00kg
	F62, F64	1.00kg	1.00kg	700gr	500gr	5.00kg	3.00kg
M35*	F61, F63	1.50kg	1.00kg	800gr	600gr	6.00kg	4.00kg
	F62, F64	1.50kg	1.00kg	800gr	600gr	6.00kg	4.00kg
M50*	F61, F63	1.00kg	750gr	700gr	500gr	5.00kg	3.00kg
	F62, F64	1.00kg	750gr	700gr	500gr	5.00kg	3.00kg
M60*	F61, F63	750gr	750gr	600gr	400gr	4.00kg	2.00kg
	F62, F64	750gr	750gr	600gr	400gr	4.00kg	2.00kg

* Note: Not included in WPA tables.

APPENDIX 4: WORLD ATHLETICS (IAAF) RULE CROSS-REFERENCE
Effective November 1, 2019, World Athletics revised the numbering of their rules. This table is intended to assist in finding the comparable rule.

WA BOOK OF RULES - BOOK C – C1.1 – COMPETITION RULES		
Rule Name	Previous IAAF Rule Reference	New WA Rule Reference
Part I – General		
Authorisation to Stage Competitions	Rule 2	Rule 1 of the Competition Rules or CR1
Regulations Governing the Conduct of International Competitions	Rule 3	Rule 2 of the Competition Rules or CR2
Part II – Competition Officials		
International Officials	Rule 110	Rule 3 of the Competition Rules or CR3
Organisational Delegates	Rule 111	Rule 4 of the Competition Rules or CR4
Technical Delegates	Rule 112	Rule 5 of the Competition Rules or CR5
Medical Delegates	Rule 113	Rule 6 of the Competition Rules or CR6
Anti- Doping Delegates	Rule 114	Rule 7 of the Competition Rules or CR7
International Technical Officials (ITOs)	Rule 115	Rule 8 of the Competition Rules or CR8
International Race Walking Judges (IRWJs)	Rule 116	Rule 9 of the Competition Rules or CR9
International Road Course Measurers	Rule 117	Rule 10 of the Competition Rules or CR10
International Starters and International Photo Finish Judges	Rule 118	Rule 11 of the Competition Rules or CR11
Jury of Appeal	Rule 119	Rule 12 of the Competition Rules or CR12
Officials of the Competition	Rule 120	Rule 13 of the Competition Rules or CR13
Competition Director	Rule 121	Rule 14 of the Competition Rules or CR14
Meeting Manager	Rule 122	Rule 15 of the Competition Rules or CR15
Technical Manager	Rule 123	Rule 16 of the Competition Rules or CR16
Event Presentation Manager	Rule 124	Rule 17 of the Competition Rules or CR17
Referees	Rule 125	Rule 18 of the Competition Rules or CR18
Judges	Rule 126	Rule 19 of the Competition Rules or CR19
Umpires (Running and Race Walking Events)	Rule 127	Rule 20 of the Competition Rules or CR20

WA BOOK OF RULES - BOOK C – C1.1 – COMPETITION RULES		
Rule Name	Previous IAAF Rule Reference	New WA Rule Reference
Timekeepers, Photo Finish Judges and Transponder Timing Judges	Rule 128	Rule 21 of the Competition Rules or CR21
Start Coordinator, Starter, Recallers	Rule 129	Rule 22 of the Competition Rules or CR22
Starter's Assistants	Rule 130	Rule 23 of the Competition Rules or CR23
Lap Scorers	Rule 131	Rule 24 of the Competition Rules or CR24
Competition Secretary, Technical Information Centre (TIC)	Rule 132	Rule 25 of the Competition Rules or CR25
Marshal	Rule 133	Rule 26 of the Competition Rules or CR26
Wind Gauge Operator	Rule 134	Rule 27 of the Competition Rules or CR27
Measurement Judge (Scientific)	Rule 135	Rule 28 of the Competition Rules or CR28
Call Room Judges	Rule 136	Rule 29 of the Competition Rules or CR29
Advertising Commissioner	Rule 137	Rule 30 of the Competition Rules or CR30
Part III – World Records		
World Records	Rule 260	Rule 31 of the Competition Rules or CR31
Events for which World Records are Recognised	Rule 261	Rule 32 of the Competition Rules or CR32
Events for which World U20 Records are Recognised	Rule 262	Rule 33 of the Competition Rules or CR33
Events for which World Indoor Records are Recognised	Rule 263	Rule 34 of the Competition Rules or CR34
Events for which World U20 Indoor Records are Recognised	Rule 264	Rule 35 of the Competition Rules or CR35
Other Records	Rule 265	Rule 36 of the Competition Rules or CR36

WA BOOK OF RULES - BOOK C – C2.1 – TECHNICAL RULES		
Rule Name	Previous IAAF Rule Reference	New WA Rule Reference
Part I – General		
General	Rule 100	Rule 1 of the Technical Rules or TR1
The Athletics Facility	Rule 140	Rule 2 of the Technical Rules or TR2
Age and Sex Categories	Rule 141	Rule 3 of the Technical Rules or TR3
Entries	Rule 142	Rule 4 of the Technical Rules or TR4
Clothing, Shoes, and Athlete Bibs	Rule 143	Rule 5 of the Technical Rules or TR5
Assistance to Athletes	Rule 144	Rule 6 of the Technical Rules or TR6
Effect of Disqualification	Rule 145	Rule 7 of the Technical Rules or TR7
Protests and Appeals	Rule 146	Rule 8 of the Technical Rules or TR8
Mixed Competition	Rule 147	Rule 9 of the Technical Rules or TR9
Surveying and Measurements	Rule 148	Rule 10 of the Technical Rules or TR10
Validity of Performance	Rule 149	Rule 11 of the Technical Rules or TR11
Video Recording	Rule 150	Rule 12 of the Technical Rules or TR12
Scoring	Rule 151	Rule 13 of the Technical Rules or TR13
Part II – Track Events		
Track Measurements	Rule 160	Rule 14 of the Technical Rules or TR14
Starting Blocks	Rule 161	Rule 15 of the Technical Rules or TR15
The Start	Rule 162	Rule 16 of the Technical Rules or TR16
The Race	Rule 163	Rule 17 of the Technical Rules or TR17
The Finish	Rule 164	Rule 18 of the Technical Rules or TR18
Timing and Photo Finish	Rule 165	Rule 19 of the Technical Rules or TR19
Seedings, Draws and Qualifications in Track Events	Rule 166	Rule 20 of the Technical Rules or TR20
Ties	Rule 167	Rule 21 of the Technical Rules or TR21
Hurdle Races	Rule 168	Rule 22 of the Technical Rules or TR22
Steeplechase Races	Rule 169	Rule 23 of the Technical Rules or TR23

WA BOOK OF RULES - BOOK C – C2.1 – TECHNICAL RULES		
Rule Name	Previous IAAF Rule Reference	New WA Rule Reference
Relay Races	Rule 170	Rule 24 of the Technical Rules or TR24
Part III – Field Events		
General Conditions – Field Events	Rule 180	Rule 25 of the Technical Rules or TR25
General Conditions – Vertical Jumps	Rule 181	Rule 26 of the Technical Rules or TR26
High Jump	Rule 182	Rule 27 of the Technical Rules or TR27
Pole Vault	Rule 183	Rule 28 of the Technical Rules or TR28
General Conditions – Horizontal Jumps	Rule 184	Rule 29 of the Technical Rules or TR29
Long Jump	Rule 185	Rule 30 of the Technical Rules or TR30
Triple Jump	Rule 186	Rule 31 of the Technical Rules or TR31
General Conditions – Throwing Events	Rule 187	Rule 32 of the Technical Rules or TR32
Shot Put	Rule 188	Rule 33 of the Technical Rules or TR33
Discus Throw	Rule 189	Rule 34 of the Technical Rules or TR34
Discus Cage	Rule 190	Rule 35 of the Technical Rules or TR35
Hammer Throw	Rule 191	Rule 36 of the Technical Rules or TR36
Hammer Cage	Rule 192	Rule 37 of the Technical Rules or TR37
Javelin Throw	Rule 193	Rule 38 of the Technical Rules or TR38
Part IV – Combined Events Competitions		
Combined Events Competitions	Rule 200	Rule 39 of the Technical Rules or TR39
Part V – Indoor Competitions		
Applicability of Outdoor Rules to Indoor Competitions	Rule 210	Rule 40 of the Technical Rules or TR40
The Indoor Stadium	Rule 211	Rule 41 of the Technical Rules or TR41
The Straight Track	Rule 212	Rule 42 of the Technical Rules or TR42
The Oval Track and Lanes	Rule 213	Rule 43 of the Technical Rules or TR43
Start and Finish on the Oval Track	Rule 214	Rule 44 of the Technical Rules or TR44
Seedings, Draw for Lanes in Track Events	Rule 215	Rule 45 of the Technical Rules or TR45

WA BOOK OF RULES - BOOK C – C2.1 – TECHNICAL RULES		
Rule Name	Previous IAAF Rule Reference	New WA Rule Reference
Clothing, Shoes and Athlete Bibs	Rule 216	Rule 46 of the Technical Rules or TR46
Hurdle Races	Rule 217	Rule 47 of the Technical Rules or TR47
Relay Races	Rule 218	Rule 48 of the Technical Rules or TR48
High Jump	Rule 219	Rule 49 of the Technical Rules or TR49
Pole Vault	Rule 220	Rule 50 of the Technical Rules or TR50
Horizontal Jumps	Rule 221	Rule 51 of the Technical Rules or TR51
Shot Put	Rule 222	Rule 52 of the Technical Rules or TR52
Combined Events Competitions	Rule 223	Rule 53 of the Technical Rules or TR53
Part VI – Race Walking Events		
Race Walking	Rule 230	Rule 54 of the Technical Rules or TR54
Part VII – Road Races		
Road Races	Rule 240	Rule 55 of the Technical Rules or TR55
Part VIII – Cross Country, Mountain and Trail Races		
Cross Country Races	Rule 250	Rule 56 of the Technical Rules or TR56
Mountain and Trail Races	Rule 251	Rule 57 of the Technical Rules or TR57

INDEX

Topic	Rule
A	
Abbreviations, Standard	132.4
Absence during competition	180.10, 181.6
Adhesive tape	170.5, 180.24(a), 181.14(a), 183.8, 187.3-4, 193.9, 302.2(g)
Aero Javelin.....	193.11
Age Groups	141
General	141
U20	141
Masters	141, 320
Youth	141, 300.1(b)
Announcer	124
Assistance	
Field Events	144, 187, 302.5(j)
General	144
Race Walking	232.4
Relays	170.20
Road Races	241.2
Shoes	143.3
Track Events	144
B	
Bandage	144.4(e)
Banking	212.8, 212.9, 219.2, 220, 221
Batons.....	127.3, 127.5, 170.4, 170.16-19, 300.2(g)
Bell	131.3
Bibs	136.5, 143.4-9, 341.6
Blocks	See Starting blocks
Blue Flag	251.5, 304.3(a)
Bona fide effort – see also Disqualification	142.4(c), 149.1, 163.4, 262.3(a)
Break Line	160.8(c), 160.9, 170.7-10, 214.2, 218
C	
Cages – Throwing	187.6, 187.9, 190, 302.5(i)
Call Room	See Clerk of Course
Call Room Referee	125.1, 125.2, 125.9
Cart Wheeling	188.2
Caution	See Warning
Assistance	144.6
Race Walking	230.2(b)
Certification	
Implements	139.2, 148.4, 187.10-14
Road Race Courses	16.8, 20.8, 21.3, 25.3, 240, 266.2
Tracks	123, 160
Change of competition area	180.1
Check Marks	163.2, 170.5, 180.23, 180.25, 302.2(g)
Clerk of Course	136, 142.1, 142.2, 170.21
Clothing- Attire	143, 302.3(d)
Combined Events	200, 223, 302.6, 332.4
Conditions for Records	260-264
Decathlon	200.1, 200.2
Heptathlon	200.2, 223.1

Indoors	223
Pentathlon	200, 201, 202, 203, 223
Referee	125.1, 125.12, 200.5, 200.7, 200.8, 200.15, 302.6(g)
Rest interval between events	200.4
Scoring	200.10, 200.11, 302.6(c), 332.4(a)
Ties	200.1, 332.4(b)
Timing	200.11
Throw-a Thon	202
Throws Pentathlon	201
Ultraweight Pentathlon	203
Competing order – Field Events	180.2, 180.3, 180.4(e)
Competition Director	111.5
Competition Secretary	132
Cross bars	181.1, 181.11-13, 181.15
Cross Country	15, 250-251
Scoring	7.4-10
Curb	160.2, 160.3
Indoor	212.2, 212.10
Replaced by cones	160.3, 212.10
Cut In Point	See Break Line

D

Decathlon	200
Delay between trials – Field Events	180.12i
Discus Throw	189
Cage	190
Disqualification from competition	125.9, 144.2, 144.6, 145, 162.15, 163.4-6(a)
Assistance	144
Combined Events	200.3(c), 200.7
Identification of infringement in results	125.7, 145, 232.3(a)
Misconduct	125.9, 145, 162.17, 242.6
Race Walking	230.3
Road Running	241.2, 242.6, 243.4
Uniform Violations	145.5
Draw	
Combined Events	200.5, 302.6
Field Events	180.2, 180.3
Track Events	166, 214, 303
Drink and refreshment stations	232.4, 241, 252.6

E

Eligibility1, 2.5, 3.1, 4
Simultaneous entries	180.9-10
Event Presentation Manager – duties	124
Event Times (Maximum).....	180.12

F

Failure	
Discus	187
Hammer	187, 191
High Jump	182.2, 182.3
Javelin	187, 193
Long Jump	185
Pole Vault	183.5-7
Shot	187, 188
Triple Jump	186

To participate	142.4, 142.5
Weight	187, 191, 195
Ultraweight	196, 203
False Start	See Start
Female	141.2
Finish line	164, 212.5-7, 244, 251.9-10
Finish of race	164.2, 212.5-8, 250.3, 251.9-12
Fixed time races	163.8-9
Photo Finish	165.2, 165.9-12

G

Gloves	4(a), 183.3, 187.3(c)
Green card	1.1(f), 162.11, 162.15 Note, 162.17(d)

H

Hammer Throw	187, 191
Cage	190
Implement details	191
Hand Timing	165.5-8
Heats – see also Draw	166, 214, 303, 332.2(k)
Heptathlon	200.2, 223.1(b), 302.6, 331.1
High Jump	181, 182
Indoors	219
Ties	181.9
Honest Participation	142.4-5, 163, 302.2(h), 332.1(d)
Horizontal Jumps	184, 185, 186, 221
Hurdles	168, 301, 302.4(a), 332.2
Indoors	217

I

Implements	See Official implements
Implements by Age Group	10.2(a), 11.2(a), 200.14, 301, 332.3(h)
Indoor Stadium	211

J

Javelin Throw	187, 193
Aero Javelin	193.11
Mini Javelin	193.10
Unorthodox technique	193.1(b)
Valid throw	193.1, 302.5(i)
Judges – duties	126
Junior (U20) Definition	141
Jury of Appeal	27.2(a), 110, 119, 125.5, 146.5, 146.8, 146.10

K

L

Lanes	160, 163, 211, 212
Lane running	163.5
Number of lanes	211.3-4
Indoors	212.3-4, 214, 214.2
Outdoors	160.1
Lap Indicator	131.3
Lap Scorer – duties	131
Leaving the track or course	163.6, 243.4
Line Clerk	130
Location change in Field Events	180.1
Long Jump	184, 185
Indoors	221

M

Manager	
Medical	110.4, 110.5
Event Presentation – duties	124
Meeting – duties	111.4
Technical – duties	123
Markers	See Check Marks
Track	163.2, 170.5, 302.2(g)
Field	180.16, 180.24-26, 181.3, 302.5(j)
Marshal – duties	133
Masters – definition	141, 320
Measurements	148, 160, 181.2, 184.8, 185.3, 187.7
Measurement Judge – duties	135, 264.2, 264.3
Mechanical Aid	144.3(d)
Medical examination	144.4, 241.1(a)
Medical staff	See Official medical staff
Meet Manager – duties	111.4
Mini Javelin	193.10
Misconduct	See Disqualification
Mixed Competition	147, 320.8, 332.1(c)
Mountain Running	252
Multi Events	See Combined Events

N

Number bibs	See Bibs
-------------------	----------

O

Obstruction	
Relay Races	170.15, 170.19, 218.5 Note
Track Events	163.4, 212.5
Official implements	10.2, 11.2, 139.2, 187-189, 191-193, 195, 196, 203, 301, 332.3
Indoor	222
Official medical staff	144, 241
Official time	165
Officials of the competition	110
Oral protest	146.3, 146.4, 146.7
Order of Events	10.2, 10.4(a), 11.2, 125.13, 166.5
Order in Field Events	180.3, 180.4(e)-(f), 180.7, 180.9(a)-(b)

P

Participation “under protest“	146.4, 146.7(b), 146.8-9, 180.4(e)
Pentathlon	200-203, 223
Photo Finish	165
Requirements of the FAT System	165.9-12
Zero control operation	165.10(c)
Zero control test for Records	260.4(c)
Photo Finish Judges	128, 165.9-14
Penalty Zone (Race Walking).....	230.3(j)
Place of Competition – change	180.1
Plasticine Indicator Board - specifications	184.5
Pole Vault	181, 183
Crossbar	181.11
Height progression	181.7
Indoors	220

Taping	183.8
Ties	181.9
Posting Board	230.3(g)
Practice trials	180.7, 180.10, 180.17
Protests and appeals	
Competing “under protest”	146.4, 146.7(b), 146.8, 180.4(e)
Eligibility to compete	146.1
Jury of Appeal	110, 119, 146.1, 146.8, 146.10
Procedures	146.2-9
Right of appeal	146.4, 146.9, 146.10
Time limits	146.2, 146.10
Q	
Qualifying competition – Field Events	180.7
Qualifying Standards	6.7, 20.6, 180.7, 180.9, 300.2(c)
R	
Race Walking	230-232
Penalty Zone	230.3(j)
Transponder Timing	165.15
Reaction time	161.6
For Records	260.4(d)
Recall Starter	110, 129, 161.4-6, 162.11, 162.14, 162.16-17
Records	260-268
Red Card – Referee	125.9, 162.17, 163.4
Red Card – Race Walking	230.3
Red flag	126.9, 251.5
Red Paddle-Race Walking	230.3
Referee	125
Appointed by	10.1, 11.1, 12.1, 27.2(b), 110.3
Protests – duties	146
Refreshments	
Race Walking	232.4
Road Races	241.2
Track Races	144.8
Relay Races	170, 302.3, 332.2(f), 332.2 (h)
Indoor events	218
Records	260-268
Rest Time between event	200.4, 214.2(e)
Results	
Announcing	124
Result card	125.7, 147, 200.8
Field Events	180.6
Signing	115.6, 125.7
Track Events	128.7, 132.2, 165.16
Road Races	
Course Certification	240.3
Drinks and refreshment stations	241
Records	261, 262, 265
Safety and medical	241
Standard distances	16, 20
Start	242
Transponder Timing	165.15, 242.7
Road Relay	
Baton/Sash	170.4

Distances	16.7, 20.4
Records	261, 262, 265

S

Seeding of Track Events	166, 303
Indoors	214
Seeding of Field Events	180.3, 180.7
Shoes	143.3, 216
Shot Put	187, 188
Indoors	222
Implement details	188
Spikes	See Shoes
Sponging	144.8, 144.9, 232.4, 241.2
Start	129, 162, 212.5-8, 242, 251.8, 252.4
Commands	162.6, 162.8, 242.5, 252.4
Cross Country	162.8, 242.5, 251.8
False start	129.3, 162, 242.5, 302.2(d), 332.2(c)
Protests	146.4-5
Reaction time	161.6
Road Races	242
Split start	162.18
Start line	162.2
Start Coordinator – see Chief Starter	129.1
Starter and Recalls – duties	129, 162, 200.3(c)
Starter’s Assistant	130
Starting Blocks	161, 302.2(e), 332.2(d)
Start Information System	125.3, 146.4-5, 161.6, 162.14
Steeplechase	169
Stop-board	187.21
Surveyor – duties	110.4, 148.1

T

Take-off board	185, 186
Take-over zones	170.3
Team Scoring	5.1(c), 7, 15.5
Technical Information Center (TIC)	132.6
Technical Manager – duties	123
Throwing Events – general conditions	187
Ties	
Combined Events	200.12
Horizontal Jumps	180.18, 180.19
Individual	9.5, 13.5(b), 167, 180.18, 180.19, 181.9, 200.12
Teams	7.6(d), 7.9(b)
Throwing Events	180.18, 180.19
Track Events	167
Vertical Jumps	181.9
Time Clock	180.12
Timing	165
Hand (HT)	165.5-8
Fully Automatic (FAT) / Photo Finish	165.9-12
Video	165.13, 165.14
Transponder	165.15, 165.16
Timekeepers – duties	128, 165, 180.12(a, b)
Chief Timekeeper	128
Appointment	110.4

Duties	128, 165, 180.12(b)
Track Measurement	160
Certification	160.9 Note
Inclination	160.5
Trail Running	252
Transponder Timing System	165.15, 165.16
For Records	265.1, 265.8
Trials recorded (Field Events)	126.8, 180.5, 180.6
Triple Jump	184, 185, 186
Indoors	221
U	
U20 Definition.....	141
Ultraweight	196
Ultraweight Pentathlon	203
Umpires – duties	110, 127, 230.1(g), 230.3(i), 243.2(a)
Uprights – High Jump	181.10
W	
Warnings	
Road Racing	125.10, 243.4
Unsporting Conduct	125.9
White Flag	126.9
Wind Gauge	
Measurement / Placement	163.10-14
Operator	110.4, 134
Y	
Yellow Card	125.9
Yellow Flag	127.4, 180.12(b), 251.5
Yellow Paddle	230.2
Youth Definition	141.1(c), 300.1

CONVERSION TABLE

METERS	FEET & DECIMALS	FEET & INCHES		
50	164.05	164		17/32"
60	196.85	196	10	7/32
100	328.09	328	1	1/32
200	656.17	656	2	1/32
300	984.26	984	3	1/32
400	1,312.34	1,312	4	1/16
500	1,640.42	1,640	5	1/16
600	1,968.51	1,968	6	1/16
800	2,624.68	2,624	8	3/32
1,000	3,280.84	3,280	10	3/32
1,500	4,921.26	4,921	3	1/8
2,000	6,561.68	6,561	8	3/16
3,000	9,842.52	9,842	6	1/4
4,000	13,123.36	13,123	4	11/32
5,000	16,404.20	16,404	2	13/32
6,000	19,685.04	19,685		1/2
7,000	22,965.88	22,965	10	9/16
8,000	26,246.72	26,246	8	21/32
9,000	29,527.56	29,527	6	3/4
10,000 (10Km.)	32,808.40	32,808	4	13/16

Kilometers

15	49,212.60	49,212	7	7/32"
20	65,616.80	65,616	9	5/8
25	82,021.00	82,021	0	
30	98,425.20	98,425	2	13/32
35	114,829.40	114,829	4	13/16
40	131,233.60	131,233	7	7/32
50	164,042.00	164,042	0	
60	196,850.40	196,850	4	13/16
70	229,658.80	229,658	9	5/8
80	262,467.20	262,467	2	13/32
90	295,275.60	295,275	7	7/32
100	328,084.00	328,084	0	