

Pipe Nipples

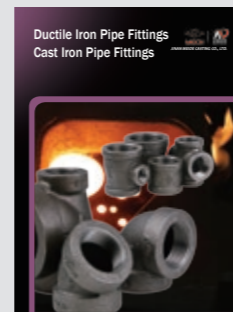

JIMSOAR INTERNATIONAL CORP.

MECH FLOW SUPPLIES

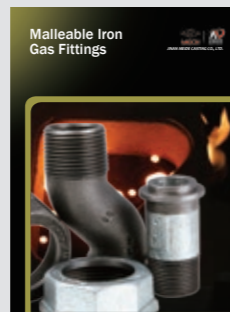
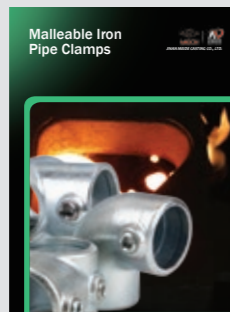
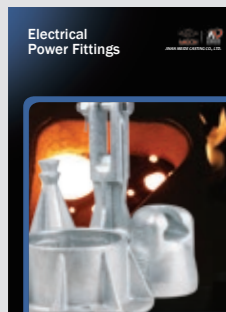
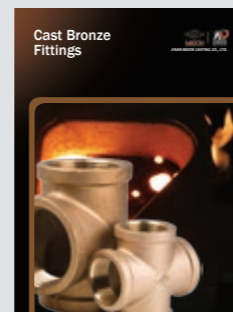
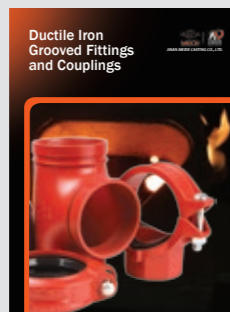
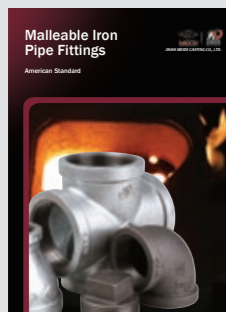

JIMSOAR INTERNATIONAL CORP.

P.O. BOX 96-10 TAIPEI, TAIWAN.

Phone: (886) 02-27040238

Fax: (886) 02-27040177

Email: jimsoar@ms13.hinet.net

Http://www.jimsoar.com

UPDATED 03/2014

Company Profile

Jimsoar International Corp., was established in 1962. In the past decades, Jimsoar has seized each opportunity to consolidate its strength, and has finally developed into what it is today, a large-scale enterprise group with advanced technology, equipment and strong comprehensive strength, known for its complete range of products, large producing capacity, high quality and strong R&D strength. The company owns altogether one main factory, three branch factories, an independent accounting steel pipe company, and a science & technology park.

The company is the largest manufacturer in the fitting industry with the most complete range of products, supplying malleable iron fittings, grooved fittings, grooved couplings, valves, cast iron fittings, ductile iron fittings, steel pipe nipples and couplings, stainless steel nipples, brass pipe nipples, cast bronze fittings, steel pipes, pipe hangers and supports, electric fittings, etc.

Over 50 years, Jimsoar has been a trusted name in piping solutions by offering high-quality products, service and support to the PVF industry continuously. We provide expertise and product solutions for a wide range of applications, plumbing, mechanical, industrial, air-conditioning and refrigeration, mining, oil, gas, fire protection, equipment and power system. Many of the company's application technology are advanced in the world, with more than 20 patents registered each year, and the company has presided over and participated in the drafting of many important national standards of the industry.

We organize the whole production process in accordance with ISO 9001 and ISO 14001. It has also the most complete certificates in the PVF industry, including UL/FM/NSF of US, CRN/cUL of Canada, DVGW/TUV/CE/VdS of Germany, BSI/LPCB of UK, SII of Israel, JIS of Japan, ABNT of Brazil, GOST-R of Russia, CNBOP of Poland, KS of South Korea, TSE of Turkey, PSB of Singapore, SIRIM of Malaysia, SABS of South Africa etc. The products are well distributed in more than 130 Countries and regions.

As an industry leader and key high-tech enterprise of the national torch plan, the company attaches great importance to environmental protection, energy-saving and emission-reduction. US-EEC recognizes MECH brand malleable iron pipe fittings as "the product to promote for the technology exchange of environmental protection". Protecting the environment is the duty of the company.

Customer satisfaction has always been the company's top objective, and we constantly stick to the principle: to provide customers with a value-added solution rather than simply delivering products.

Company History

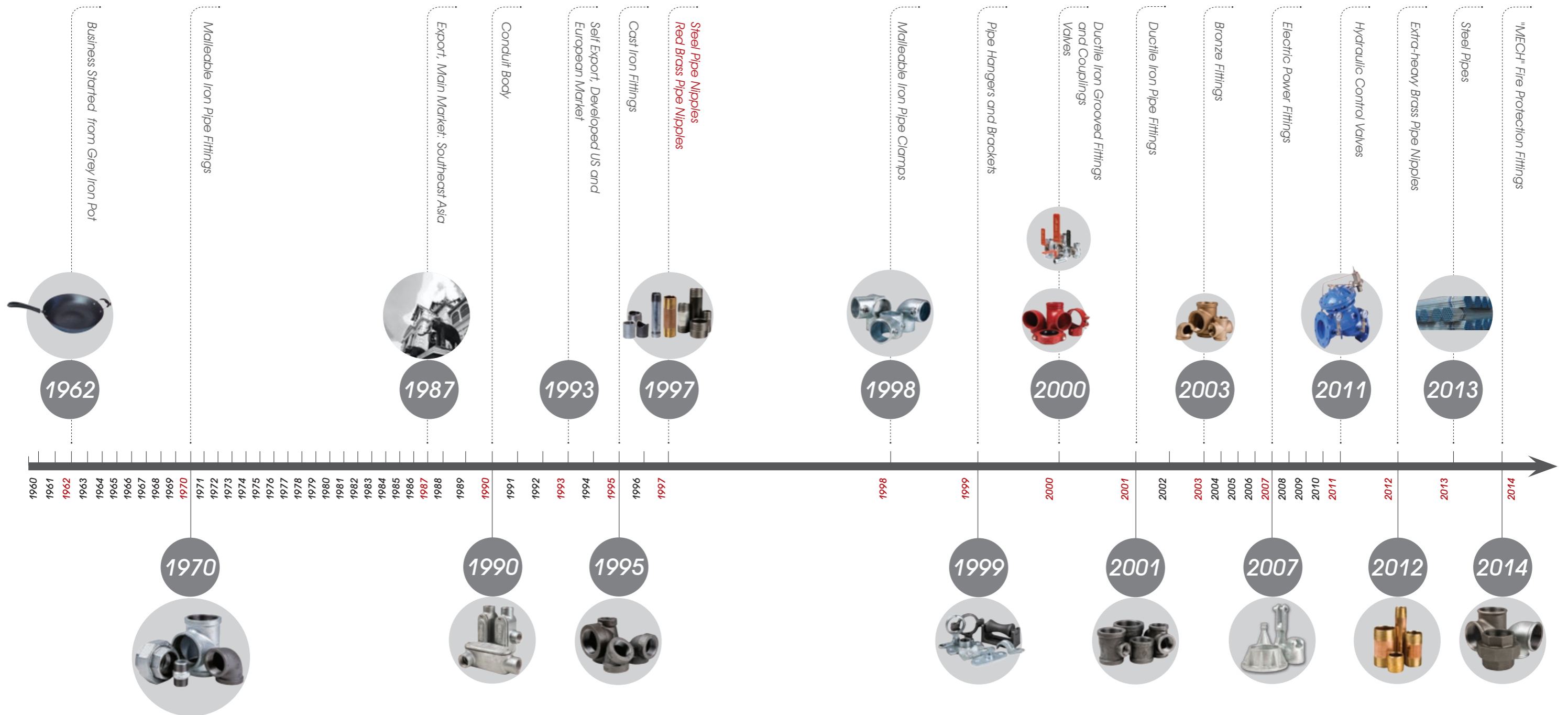

Certificates



Brass Pipe Nipple



Material : ASTM B43
 Dimensions : ASTM B687
 Threads: ASME B1.20.1, ISO 7/1
 Schedule : Standard/Extra Heavy

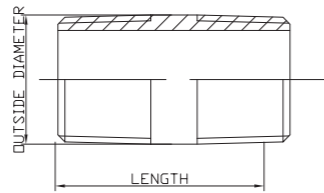

Brass Pipe Nipple Standard/Extra Heavy																		
Pipe Size	Pipe O.D.	Length Close	Pipe Nipple Lengths (In)															
In	In	In	1/2	2	2 1/2	3	3 1/2	4	4 1/2	5	5 1/2	6	7	8	9	10	11	12
1/8	0.405	3/4	1/2	2	2 1/2	3	3 1/2	4	4 1/2	5	5 1/2	6	7	8	9	10	11	12
1/4	0.540	7/8	1/2	2	2 1/2	3	3 1/2	4	4 1/2	5	5 1/2	6	7	8	9	10	11	12
3/8	0.675	1	1/2	2	2 1/2	3	3 1/2	4	4 1/2	5	5 1/2	6	7	8	9	10	11	12
1/2	0.840	1 1/8	1/2	2	2 1/2	3	3 1/2	4	4 1/2	5	5 1/2	6	7	8	9	10	11	12
3/4	1.050	1 3/8	1/2	2	2 1/2	3	3 1/2	4	4 1/2	5	5 1/2	6	7	8	9	10	11	12
1	1.315	1 1/2	1/2	2	2 1/2	3	3 1/2	4	4 1/2	5	5 1/2	6	7	8	9	10	11	12
1-1/4	1.660	1 5/8	X	2	2 1/2	3	3 1/2	4	4 1/2	5	5 1/2	6	7	8	9	10	11	12
1-1/2	1.900	1 3/4	X	2	2 1/2	3	3 1/2	4	4 1/2	5	5 1/2	6	7	8	9	10	11	12
2	2.375	2	X	2	2 1/2	3	3 1/2	4	4 1/2	5	5 1/2	6	7	8	9	10	11	12
2-1/2	2.875	2 1/2	X	X	2 1/2	3	3 1/2	4	4 1/2	5	5 1/2	6	7	8	9	10	11	12
3	3.500	2 5/8	X	X	X	3	3 1/2	4	4 1/2	5	5 1/2	6	7	8	9	10	11	12
4	4.500	2 7/8	X	X	X	3	3 1/2	4	4 1/2	5	5 1/2	6	7	8	9	10	11	12
5	5.562	3	X	X	X	3	3 1/2	4	4 1/2	5	5 1/2	6	7	8	9	10	11	12
6	6.625	3 1/8	X	X	X	X	3 1/2	4	4 1/2	5	5 1/2	6	7	8	9	10	11	12
8	8.625	3 1/2	X	X	X	X	3 1/2	4	4 1/2	5	5 1/2	6	7	8	9	10	11	12

Noted: Other lengths and size available. Contact us for details.

Steel Pipe Nipple with American Standard



Material : ASTM A53/A106/A333
 Dimensions : ASTM A733
 Threads : ASME B1.20.1
 Schedule : 40/80/160/XXS

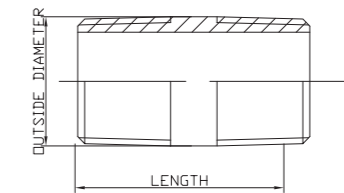

Carbon Steel Pipe Nipple Sch.40/80/160/XXS, Welded/Seamless																		
Pipe Size	Pipe O.D.	Length Close	Pipe Nipple Lengths (In)															
In	In	In	1/2	2	2 1/2	3	3 1/2	4	4 1/2	5	5 1/2	6	7	8	9	10	11	12
1/8	0.405	3/4	1/2	2	2 1/2	3	3 1/2	4	4 1/2	5	5 1/2	6	7	8	9	10	11	12
1/4	0.540	7/8	1/2	2	2 1/2	3	3 1/2	4	4 1/2	5	5 1/2	6	7	8	9	10	11	12
3/8	0.675	1	1/2	2	2 1/2	3	3 1/2	4	4 1/2	5	5 1/2	6	7	8	9	10	11	12
1/2	0.840	1 1/8	1/2	2	2 1/2	3	3 1/2	4	4 1/2	5	5 1/2	6	7	8	9	10	11	12
3/4	1.050	1 3/8	1/2	2	2 1/2	3	3 1/2	4	4 1/2	5	5 1/2	6	7	8	9	10	11	12
1	1.315	1 1/2	1/2	2	2 1/2	3	3 1/2	4	4 1/2	5	5 1/2	6	7	8	9	10	11	12
1-1/4	1.660	1 5/8	X	2	2 1/2	3	3 1/2	4	4 1/2	5	5 1/2	6	7	8	9	10	11	12
1-1/2	1.900	1 3/4	X	2	2 1/2	3	3 1/2	4	4 1/2	5	5 1/2	6	7	8	9	10	11	12
2	2.375	2	X	2	2 1/2	3	3 1/2	4	4 1/2	5	5 1/2	6	7	8	9	10	11	12
2-1/2	2.875	2 1/2	X	X	2 1/2	3	3 1/2	4	4 1/2	5	5 1/2	6	7	8	9	10	11	12
3	3.500	2 5/8	X	X	X	3	3 1/2	4	4 1/2	5	5 1/2	6	7	8	9	10	11	12
4	4.500	2 7/8	X	X	X	3	3 1/2	4	4 1/2	5	5 1/2	6	7	8	9	10	11	12
5	5.563	3	X	X	X	3	3 1/2	4	4 1/2	5	5 1/2	6	7	8	9	10	11	12
6	6.625	3 1/8	X	X	X	X	3 1/2	4	4 1/2	5	5 1/2	6	7	8	9	10	11	12
8	8.625	3 1/2	X	X	X	X	3 1/2	4	4 1/2	5	5 1/2	6	7	8	9	10	11	12

Noted: Other lengths and size available. Grooved end, SQ end and Bevel end available. Contact us for details.

Steel Pipe Nipple with British/Din Standard



Material : BS EN 10241
 Dimensions : BS EN 10241
 Threads : ISO7/1
 Schedule : Medium/Heavy

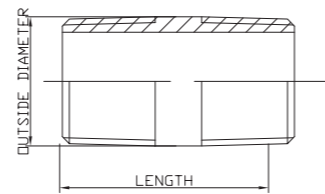

Carbon Steel Pipe Nipple Medium/Heavy ,Welded/Seamless																		
Pipe Size	Pipe O.D.	Length Close	Pipe Nipple Lengths (mm)															
mm	mm	mm																
6	10.3	19	30	40	50	60	80	100	120	150	180	200	250	300	350	400	450	500
8	13.7	27	30	40	50	60	80	100	41/2	150	180	200	250	300	350	400	450	500
10	17.1	28	30	40	50	60	80	100	41/2	150	180	200	250	300	350	400	450	500
15	21.3	37	X	40	50	60	80	100	41/2	150	180	200	250	300	350	400	450	500
20	26.7	39	X	40	50	60	80	100	41/2	150	180	200	250	300	350	400	450	500
25	33.4	46	X	X	50	60	80	100	41/2	150	180	200	250	300	350	400	450	500
32	42.2	51	X	X	50	60	80	100	41/2	150	180	200	250	300	350	400	450	500
40	48.3	51	X	X	50	60	80	100	41/2	150	180	200	250	300	350	400	450	500
50	60.3	60	X	X	X	60	80	100	41/2	150	180	200	250	300	350	400	450	500
65	76.1	69	X	X	X	X	80	100	41/2	150	180	200	250	300	350	400	450	500
80	88.9	75	X	X	X	X	80	100	41/2	150	180	200	250	300	350	400	450	500
100	114.3	87	X	X	X	X	X	100	41/2	150	180	200	250	300	350	400	450	500
125	141.3	96	X	X	X	X	X	X	120	150	180	200	250	300	350	400	450	500
150	168.3	96	X	X	X	X	X	X	120	150	180	200	250	300	350	400	450	500

Noted: Other lengths and size available. Grooved end, SQ end and Bevel end available. Contact us for details.



Stainless Steel Nipple with American Standard



Material : ASTM A312/A312M
 Dimensions : ASTM A733
 Threads : ASME B1.20.1
 Schedule : 40/80

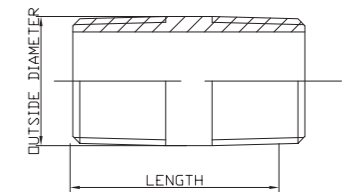

Stainless Steel Nipple Sch.40/80, Welded/Seamless																		
Pipe Size	Pipe O.D.	Length Close	Pipe Nipple Lengths (In)															
In	In	In																
1/8	0.405	3/4	1 1/2	2	2 1/2	3	3 1/2	4	4 1/2	5	5 1/2	6	7	8	9	10	11	12
1/4	0.540	7/8	1 1/2	2	2 1/2	3	3 1/2	4	4 1/2	5	5 1/2	6	7	8	9	10	11	12
3/8	0.675	1	1 1/2	2	2 1/2	3	3 1/2	4	4 1/2	5	5 1/2	6	7	8	9	10	11	12
1/2	0.840	1 1/8	1 1/2	2	2 1/2	3	3 1/2	4	4 1/2	5	5 1/2	6	7	8	9	10	11	12
3/4	1.050	1 3/8	1 1/2	2	2 1/2	3	3 1/2	4	4 1/2	5	5 1/2	6	7	8	9	10	11	12
1	1.315	1 1/2	1 1/2	2	2 1/2	3	3 1/2	4	4 1/2	5	5 1/2	6	7	8	9	10	11	12
1-1/4	1.660	1 5/8	X	2	2 1/2	3	3 1/2	4	4 1/2	5	5 1/2	6	7	8	9	10	11	12
1-1/2	1.900	1 3/4	X	2	2 1/2	3	3 1/2	4	4 1/2	5	5 1/2	6	7	8	9	10	11	12
2	2.375	2	X	2	2 1/2	3	3 1/2	4	4 1/2	5	5 1/2	6	7	8	9	10	11	12
2-1/2	2.875	2 1/2	X	X	2 1/2	3	3 1/2	4	4 1/2	5	5 1/2	6	7	8	9	10	11	12
3	3.500	2 5/8	X	X	X	3	3 1/2	4	4 1/2	5	5 1/2	6	7	8	9	10	11	12
4	4.500	2 7/8	X	X	X	3	3 1/2	4	4 1/2	5	5 1/2	6	7	8	9	10	11	12
5	5.563	3	X	X	X	3	3 1/2	4	4 1/2	5	5 1/2	6	7	8	9	10	11	12
6	6.625	3 1/8	X	X	X	X	3 1/2	4	4 1/2	5	5 1/2	6	7	8	9	10	11	12
8	8.625	3 1/2	X	X	X	X	3 1/2	4	4 1/2	5	5 1/2	6	7	8	9	10	11	12

Noted: Other lengths and size available. Grooved end, SQ end and Bevel end available. Contact us for details.



Steel Merchant Coupling with American Standard

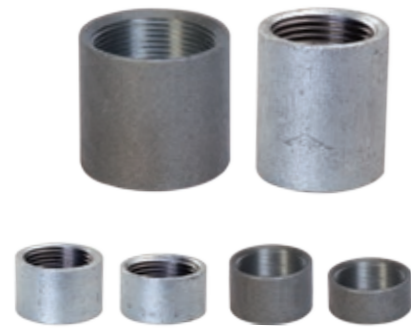

Material : ASTM A865
 Dimensions : ASTM A865
 Threads : ASME B1.20.1
 Schedule : Standard

Size	In	1/8	1/4	3/8	1/2	3/4	1	1 1/4	1 1/2	
Full	Pipe O.D.	In	0.563	0.719	0.875	1.063	1.313	1.576	1.900	2.200
	Length	In	3/4	1-1/8	1-1/8	1-1/2	1-9/16	1-15/16	2	2
Half	Pipe O.D.	In	0.563	0.719	0.875	1.063	1.313	1.576	1.900	2.200
	Length	In	0.335	0.531	0.531	0.709	0.748	0.925	0.965	0.965

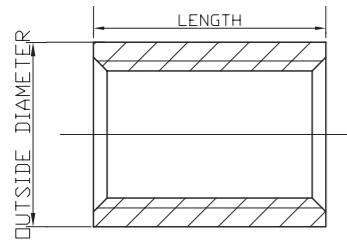

Size	In	2	2 1/2	3	3 1/2	4	5	6	
Full	Pipe O.D.	In	2.75	3.250	4.000	4.625	5.000	6.296	7.390
	Length	In	2-1/16	3-1/16	3-3/16	3-5/16	3-7/16	3-11/16	3-15/16
Half	Pipe O.D.	In	2.75	3.250	4.000	4.625	5.000	6.296	7.390
	Length	In	1.051	1.496	1.555	1.634	1.673	1.811	1.949

Noted: Other lengths and size available, contact us for details

Steel Merchant Coupling with American Standard

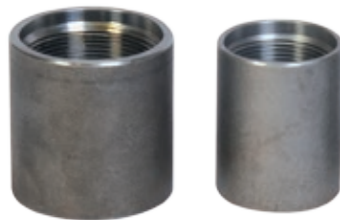

Material : ASTM A865
 Dimensions : ASTM A865
 Threads : ASME B1.20.1
 Schedule : Extra-Strong

Size	In	1/8	1/4	3/8	1/2	3/4	1	1 1/4	1 1/2	
Standard	Pipe O.D.	In	0.563	0.719	0.875	1.063	1.313	1.576	2.054	2.2
	Length	In	1-1/18	1-5/8	1-5/8	2-1/8	2-1/8	2-5/8	2-3/4	2-3/4

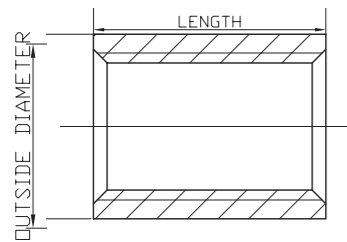

Size	In	2	2 1/2	3	3 1/2	4	5	6	
Standard	Pipe O.D.	In	2.875	3.375	4.0	4.625	5.2	6.296	7.39
	Length	In	2-7/8	4-1/8	4-1/4	4-3/8	4-1/2	4-5/8	4-7/8

Noted: Other lengths and size available, contact us for details

Steel Socket with British/Din Standard



Material : BS EN 10241
 Dimensions : BS EN 10241
 Threads : ISO 7/1
 Schedule : Medium

Size	mm	6	8	10	15	20	25	32	
Standard	Pipe O.D.	mm	15.0	18.5	21.3	26.6	31.8	39.5	48.3
	Length	mm	17	25	26	34	36	43	48
Half	Pipe O.D.	mm	15	18.5	22	27	32.5	39.5	49
	Length	mm	8	11	12	16	19	21	25

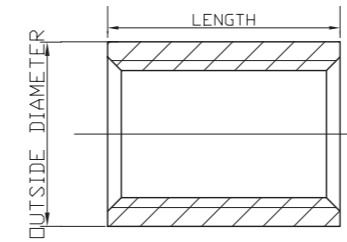

Size	mm	40	50	65	80	100	125	150	
Standard	Pipe O.D.	mm	54.5	66.2	82	95	121.4	146.3	173.3
	Length	mm	48	56	65	71	83	92	92
Half	Pipe O.D.	mm	56	68	84	98	124	151	177
	Length	mm	25	28	30	35	40	44	44

Noted: Other lengths and size available, contact us for details

Steel Socket with British/Din Standard

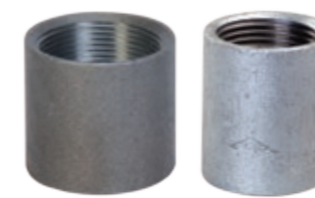

Material : BS EN 10241
 Dimensions : BS EN 10241
 Threads : ISO 7/1
 Schedule : Heavy

Size	mm	6	8	10	15	20	25	32	
Standard	Pipe O.D.	mm	15.0	18.5	21.3	26.6	31.8	39.5	48.3
	Length	mm	19.0	27.0	28.0	37.0	39.0	46.0	51.0

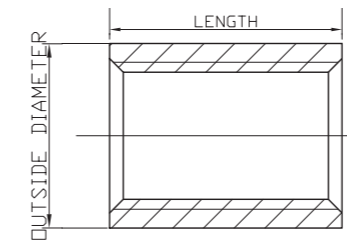

Size	mm	40	50	65	80	100	125	150	
Standard	Pipe O.D.	mm	54.5	66.2	82	95	121.4	146.3	173.3
	Length	mm	51.0	60.0	69.0	75.0	87.0	96.0	96.0

Noted: Other lengths and size available, contact us for details

Steel Nipple-Tank Type

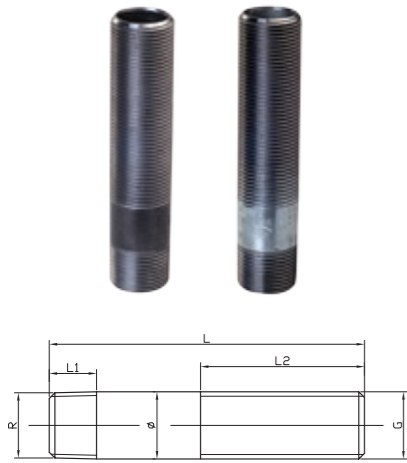

Size	L+2(mm)	L1 (mm)	L2(mm)	Ø (mm)	R	G
1/2X100X52MM	100	15	52	21.3	R1/2	G1/2
3/4X100X54MM	100	15	54	26.7	R3/4	G3/4
1X100X62MM	100	17	62	33.4	R1	G1
1 1/4X150X70MM	150	20	70	42.2	R1 1/4	G1 1/4
1 1/2X150X71MM	150	20	71	48.3	R1 1/2	G1 1/2
2X150X82MM	150	23	82	60.3	R2	G2

Threaded Welded Outlet

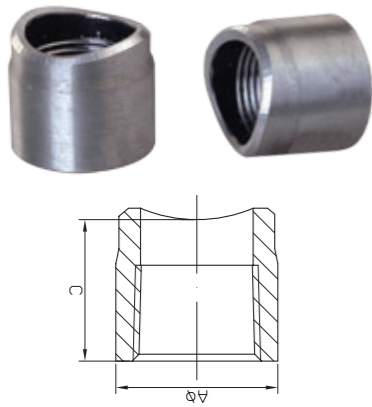

Material : ASTM A106
Threads : ASME B1.20.1, ISO 7/1

Size	In	1/2	3/4	1	1 1/4	1 1/2	2	2 1/2	3	4
Pipe Run Size	In	1 to 4	1 to 4	1 1/4 to 6	1 1/2 to 6	2 to 6	3 to 6	3 to 8	4 to 8	6 to 8
A	In	1.083	1.331	1.555	1.870	2.165	2.724	3.209	3.957	4.961
C	In	1.063	1.126	1.248	1.374	1.626	1.752	2.217	2.500	3.000

Grooved Welded Outlet

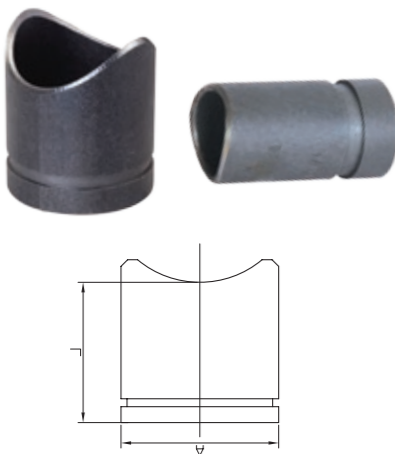

Material : ASTM A53
Groove : AWWA C606 and ISO 6182-12

Size	In	1 1/4	1 1/2	2	2 1/2	3	4	6	8
Pipe Run Size	In	1 1/4-8	1 1/2-8	2-8	2 1/2-8	3-8	4-8	6-8	8
A	In	1.660	1.900	2.375	2.875	3.500	4.500	6.625	8.625
L	In	2.969	2.969	2.969	2.969	2.969	3.976	3.976	4

Steel Dielectric Nipple

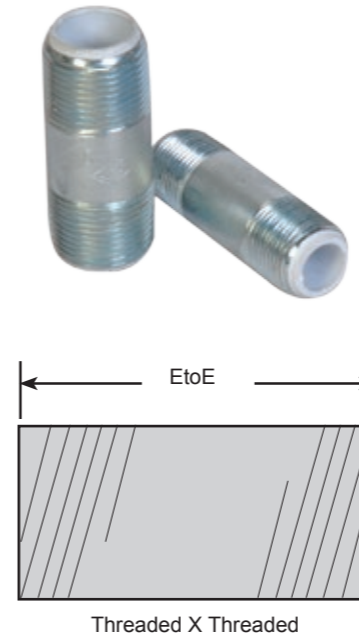

Nominal Dia. (inches)	Out. Dia. (inches)	Max. Work. Press. (PSI/kPa)	End to End (inches)	Aprx. Wgt. Each (Lbs./kg)
1/2	0.840	300 / 2065	2-1/2	0.15 / 0.07
1/2	0.840	300 / 2065	3	0.18 / 0.08
3/4	1.050	300 / 2065	2	0.15 / 0.07
3/4	1.050	300 / 2065	2-1/2	0.20 / 0.09
3/4	1.050	300 / 2065	3	0.24 / 0.11
3/4	1.050	300 / 2065	4	0.34 / 0.15
1	1.315	300 / 2065	2-1/2	0.27 / 0.12
1	1.315	300 / 2065	3	0.34 / 0.15
1	1.315	300 / 2065	4	0.48 / 0.22
1-1/4	1.660	300 / 2065	4	0.65 / 0.30
1-1/2	1.900	300 / 2065	4	0.78 / 0.36
2	2.375	300 / 2065	4	1.06 / 0.48
2-1/2	2.875	300 / 2065	6	2.47 / 1.12
3	3.500	300 / 2065	6	3.23 / 1.47
3-1/2	4.000	300 / 2065	6	3.90 / 1.77
4	4.500	300 / 2065	6	4.61 / 2.10

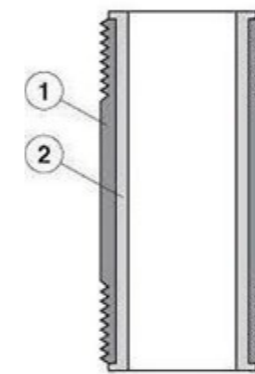

Material Specifications:

- 1. Body: Carbon steel pipe to ASTM A-53 type E, zinc electroplated.
- 2. Liner: Polypropylene (PP) plastic
- Dimension: ASTM A733
- Thread: ASME B1.20.1
- Working Pressure: 300 psi
- Temperature Range: 32°F to 230°F
- For cool or heat water supply, good corrosion resistance in water. Plastic-lined steel nipples act as an insulator to prevent destructive electrolytic corrosion between dissimilar metals.
- Crosslinked polyethylene (PEX) plastic, and polyethylene (PE) plastic available when ask.
- Meets NSF / ANSI 372 lead free requirement

Insert Adapter

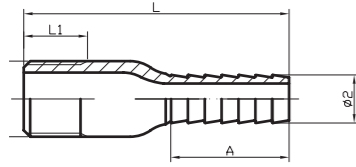

Size(In)	L±1.2(mm)	L1±1(mm)	Ø2±0.2	A±1
1/2	79	19.8	16.8	32.9
3/4	79	20	21.2	32.9
1	83.5	25	27.3	32.9
1 1/4	90	25.5	36.3	32.9
1 1/2	103.5	26	41.9	43.4
2	103.5	26.5	53	44.8
2 1/2	131	39.9	63.5	56(8 bar)
3	163	41.5	80	64(8 bar)
4	174	44	102.5	72(8 bar)
6	182	49.4	155	72(8 bar)

- Features:
- Pipe: Carbon steel
 - Thread: NPT / BSP
 - Extra long barb is available upon request.
 - Plated male adapter meets NSF / ANSI 372 lead free requirement.
 - Plated steel for greater corrosion resistance than unplated steel, prevent rust and weathering.
 - Common use: Cold water sprinkler, irrigation, and pump installation.
 - Other sizes available, contact us for details.

Combination Nipple

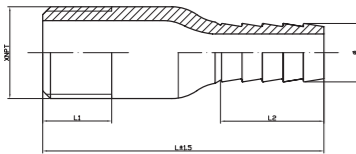

Size(In)	L±1.5(mm)	L1(mm)	L2(mm)	φ
1/2	79.5	17.5	35	13.5
3/4	81	17.5	35	19.8
1	89	20.5	35	26.2
1 1/4	95	21.5	43	32.5
1 1/2	112.5	22	51	38.6
2	124	22	51	51.3

- Features:
- Pipe: Carbon steel
 - Thread: NPT / BSP
 - Barbed end to create a tight seal on a hose when used with a hose clamp or crimpsleeve, and male NPT / BSP thread on the other end to connection. connect to female NPT / BSP threaded.
 - Plated steel for greater corrosion resistance than unplated steel, prevent rust and weathering.
 - Recommended for low-pressure discharge or suction applications. Not for air service or steam service.
 - The working pressure varies with the construction of the hose, and the application, shall not exceed the working pressure of the lowest rated component in the hose system.
 - Other sizes available, contact us for details.

Insert Coupling

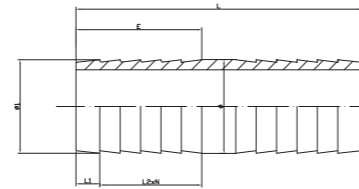

Size	L±1.5(mm)	φ	φ1±0.15	E±1(mm)	L1±0.1(mm)	L2±0.1(mm)	N
1/2X80	80	17	16.5	37	7	5	6
3/4X82	82	22	21.6	37	7	5	6
1X84	84	28	27.5	37	7	5	6
1 1/4X90	90	36.5	35.8	44	8	6	6
1 1/2X102	102	42.5	41.9	44	8	6	6
2X107	107	54.5	53.6	50	8	7	6

- Features:
- Pipe: Carbon steel
 - Plated male adapter meets NSF / ANSI 372 lead free requirement.
 - Plated steel for greater corrosion resistance than unplated steel, prevent rust and weathering.
 - Common use: Cold water sprinkler, irrigation, and pump installation.
 - Other sizes available, contact us for details.

Hose Mender

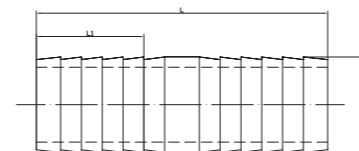

Size	L (mm)	L1 (mm)	φ1
1/2	89	35	13.5
3/4	89	35	19.8
1	89	35	26.2
1 1/4	108	43	32.5
1 1/2	118	51	38.6
2	123	51	51.3

- Features:
- Material: Plated steel, unplated steel
 - Type: Insert x Insert.
 - Barbed end to create a tight seal on a hose when used with a hose clamp or crimpsleeve
 - Plated steel for greater corrosion resistance than unplated steel, prevent rust and weathering.
 - Recommended for low-pressure discharge or suction applications. Not for air service or steam service.
 - The working pressure varies with the construction of the hose, and the application, shall not exceed the working pressure of the lowest rated component in the hose system.
 - Other sizes available, contact us for details.

