

sure-loc®



Professional Grade Landscape Edging



ALUMINUM
EDGING

STEEL
EDGING

PLASTIC
EDGING

ALUMINUM
PAVER
RESTRAINTS

PLASTIC
PAVER
RESTRAINTS



SIMPLE. SEAMLESS. SURE-LOC.™

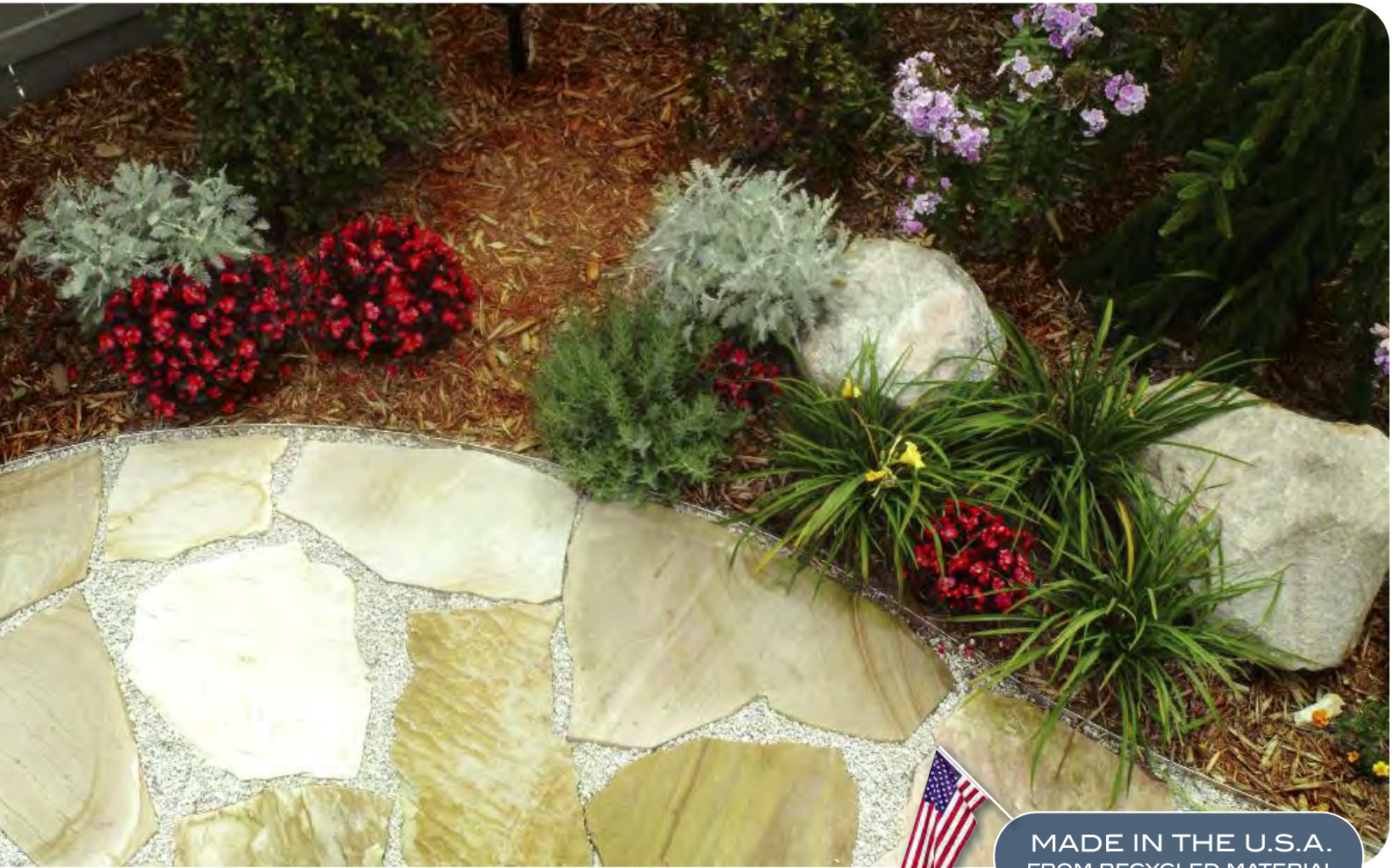
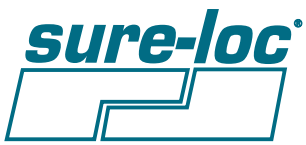

OUR PHILOSOPHY

Landscaping is the most visible and noticeable feature of a house, building, park, streetscape or any other project. A project never looks complete until the landscaping is added. The landscaping should have clean lawn lines with sharp borders and have well defined bed areas and walkways. Sure-loc edging adds crisp, clean lines which defines the spaces and makes the difference between a good landscape and a great one.

Making beautiful, functional landscapes requires knowledge, preparation, and hard work. Helping these landscapes withstand the test of time, requires Sure-loc Edging. When specifying Sure-loc edging, an architect can be confident that their design will be maintained for a lifetime.

OUR HISTORY

Sure-loc Edging Inc was founded in 1992 when the owner, Roger Blauwkamp, saw the need in the market for, and designed, an aluminum edging that didn't have overlapping joints and had end stake adaptors that would allow staking at any point. Since then our company has expanded our product line to offer a complete line of landscape edging.

OUR PRODUCTS

Sure-loc manufactures and supplies a complete line of landscape edging products including: Aluminum edging, Steel edging, Aluminum Paver Restraints and Plastic Paver Restraints.

Sure-loc aluminum edging is manufactured at our home base in Holland, Michigan and most of our products are made in the U.S.A. from recycled material. Sure-loc products have grown to be recognized globally for their quality and features. In fact it has been said that we are "ridiculously obsessed with quality."



FOR MORE INFO, VISIT: www.surelocedging.com OR SCAN:

SURE-LOC ALUMINUM EDGING BENEFITS

- Lifetime performance makes the cost of aluminum edging lower than any other product.
- High strength aluminum alloy withstands years of maintenance abuse
- The resilient flexibility of aluminum allows for smoother curves.
- Crisp, straight lines can be achieved with minimal effort.
- Aluminum is recycled & non-toxic with excellent corrosion resistance & high thermal conductivity.
- Aluminum edging is light weight, forms easily and can be cut to length at the construction site with minimal effort which saves time and lowers installation costs
- Aluminum edging will NEVER: rust or corrode like steel edging; rot, fade or splinter like wood edging; or crack and become brittle like vinyl and plastic edging.
- Can be installed with ease, and creates beautiful curves and crisp straight runs
- Has virtually no maintenance

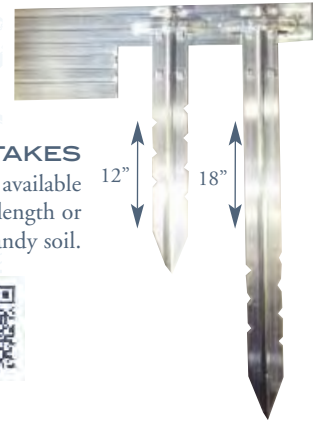
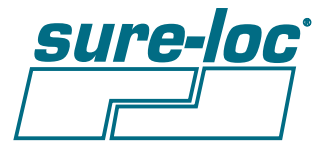

ALUMINUM STAKES
Wider, more rigid stakes available in all colors, in standard 12" length or extra long 18" length for sandy soil.

FOR TECHNICAL SPECIFICATIONS & CAD DETAILS VISIT

www.surelocedging.com/project-planning/technical-specifications/ OR SCAN QR:



SURE-LOC ALUMINUM EDGING FEATURES

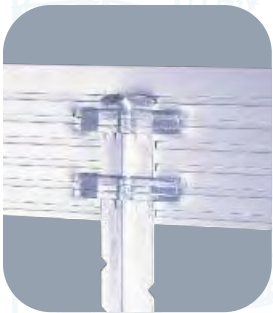

"INVISIBLE" STAKE POCKETS

Stakes are below grade and therefore not seen in finished project



END STAKE ADAPTERS

Allows for staking at any point. Available in all colors & depths



DUAL STAKE LOCKING SYSTEM

Creates seamless connection with no overlapping joints



DUAL STAKE POCKETS

Guides stake straight down & holds stake securely to edging

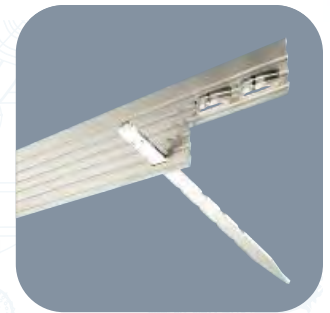

ANTI-FROST HEAVE TECHNOLOGY

Stake pocket accepts stakes at 45° angle to keep edging in ground



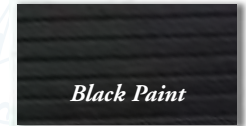

AVAILABLE FINISHES

All sizes are available in Mill Finish and Black Anodized.

Green, Brown, Bronze & Black Paint are available in 1/8" x 4" Sizes (8' & 16') and 3/16" x 4" x 16'.

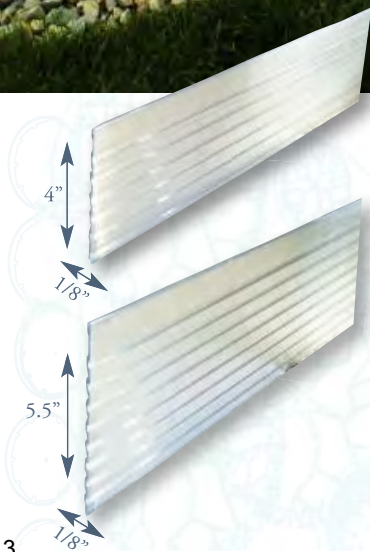

1/8" x 4"

CRISP-EDGE® Primarily used in residential and light commercial applications where greater flexibility is desired. Prolonged straight runs are possible but will require additional labor. Applications include, but are not limited to, planting beds, tree rings, paver walkways and paths.

Edging is packaged 15 pieces (240') per box (16 ft sections) or 15 pieces (120') per box (8 ft sections).

Available colors: Mill, Black anodized, Black paint, Brown paint, bronze paint, green paint

1/8" x 5.5"

CRISP-EDGE® Similar applications as 1/8" x 4" but used where additional depth would be beneficial.

Edging is packaged 15 pieces (240') per box (16 ft sections).

Available Colors: Mill, Black anodized



END STAKE ADAPTERS

Available in all colors & depths



3/16" x 4"

SURE-EDGE® Primarily used in commercial, industrial, institutional projects, and other high traffic areas. Straight runs are easier than with 1/8" material with only slightly reduced flexibility. Applications include, but are not limited to, driveways, asphalt, maintenance strips, running tracks, and pathways.

Edging is packaged 10 pieces (160') per box (16 ft sections).

Available colors: Mill, Black anodized, Black paint, Brown paint, green paint

3/16" x 5.5"

SURE-EDGE® Similar applications as 3/16" x 4" but used where additional depth would be beneficial.

Edging is packaged 10 pieces (160') per box (16 ft sections).

Available Colors: Mill, Black anodized

3/16" x 8"

SURE-EDGE® Similar applications as 3/16" x 5.5" but used where additional depth would be beneficial such as sandy soil, steep elevations or specialty projects.

Edging is packaged 5 pieces (80') per box (16 ft sections).

Available Colors: Mill, Black anodized

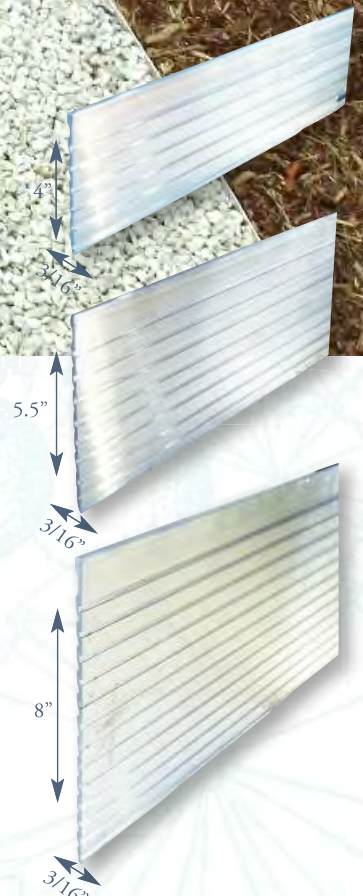



*Work in progress, using Sure-loc Black Anodized Aluminum Edging.
Note the fluid curves and defined spaces.*

Sure-loc Edging really is as easy to install as 1, 2, 3.

INSTALLS WITH EASE

Whether your project is large or small, includes straight runs or lots of curves, Sure-loc has an edging to fit your needs. With our patent pending “puzzle like” locking system, you can seamlessly and securely connect each section of edging together using two stakes that are below grade. No one will know where the end points are. And, at the end of the landscape bed, simply cut the material with a hacksaw and slide an end stake adaptor over the edging which allows you to add stakes at any point.

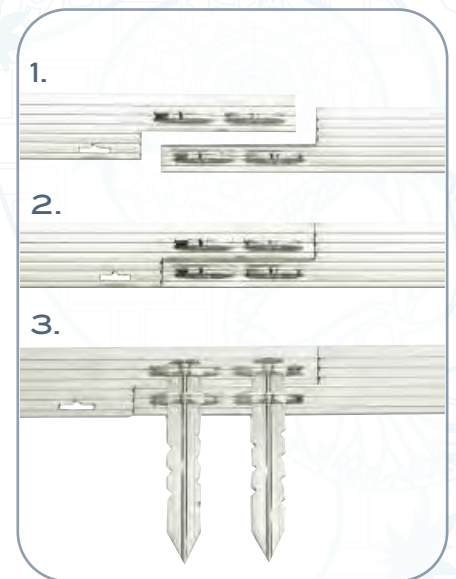

TO WATCH A HOW-TO INSTALL VIDEO
OR DETAILED INSTRUCTIONS,
SCAN QR CODE OR VISIT:
www.surelocedging.com/project-planning/installation







APPLICATIONS

- LANDSCAPE BEDS
- TREE RINGS
- WALKWAYS & PATHWAYS
- BRICK OR STONE PATIOS
- GARDENS
- DRIP EDGES
- AND MORE

FEATURES

- Easy "sliding" installation
- Permanent & virtually maintenance free
- Will not rust, rot, crack, or become brittle
- Creates straight runs or curves with ease
- Our most cost effective aluminum edging



MADE IN THE U.S.A.
FROM RECYCLED MATERIAL

EASY TO INSTALL: SIMPLY SLIDE ENDS TOGETHER & INSERT SPIKES

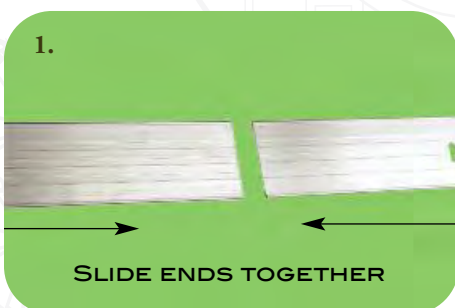



FOR HOW-TO
INSTALL VIDEO &
DETAILED
INSTRUCTIONS,
scan QR Code or visit:
www.surelocedging.com



INSTALLATION INSTRUCTIONS



1. DIG A 4" TRENCH



2. PLACE EDGING IN TRENCH



3. SLIDE EDGING TOGETHER



4. CUT EDGING TO LENGTH



5. HAMMER STAKES AT 45°



5. BACKFILL 1/2' BELOW EDGING

AVAILABLE FINISHES

BLACK MILL BRONZE GREEN BROWN



90° CORNERS
are available in all colors

BOX CONTENTS

4 - 6ft Sections aluminum edging (24 ft total) 12 - Metal Stakes





MADE IN THE U.S.A.
FROM RECYCLED MATERIAL

Sure-Loc steel edging offers your landscape design a permanent solution to edge control. With a variety of sizes to choose from, steel edging gives you strength to stand up to the most demanding applications and flexibility for creative design possibilities.

Sure-loc steel edging is painted for long lasting durability and prefabricated for easy connections. All edging is provided with stakes for a permanent installation.

QUALITY FEATURES:

- Will not become brittle or decay compared to wood or plastic edging.
- Is extremely durable and is not easily damaged by maintenance equipment.
- Stays in the ground due to our dual stake locking system and it's substantial weight.
- Creates a permanent and maintenance free solution for all your landscape edging needs.
- Maintains strict material tolerances, ensuring no compromise in thickness of edging.
- Has high quality powder coating to ensure the material is evenly coated, fully covered, and will not chip or fade like spray or vat dipped paint. Powder coating also makes
- Sure-loc Steel edging resistant to PH swings in highly alkaline soils, minimizing corrosion.



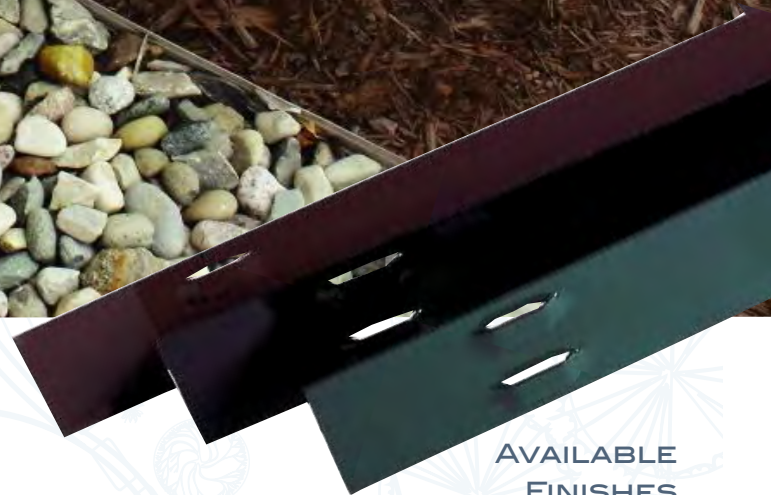

AVAILABLE FINISHES

BLACK BROWN GREEN GALVANIZED UNPAINTED

SIZES & APPLICATIONS

14 ga. x 4" x 10'



.070 - .075" Average thickness. Primarily used in residential applications where imaginative, free-form design is combined with long-term performance and strength not found in wood or plastic edging.

1/8" x 4" x 16'



.120 - .125" Average thickness. Primarily used in residential applications where flexibility and durability are a necessity. This versatile edging will meet most landscape needs. Applications include, but are not limited to, planting beds, tree rings, paver walkways, paths, and mulch bed divisions. 24" Radius is possible.

3/16" x 4" x 16'



.182 - .188" Average thickness. Primarily used in commercial, industrial, institutional projects, and other high traffic areas. Straight runs are easier than with 1/8" material with only slightly reduced flexibility. Applications include, but are not limited to, driveways, asphalt, maintenance strips, running tracks, pathways, and bed division. 36" radius is possible.

1/4" x 5" x 16'



.20 - .25" Average thickness. Primarily used in commercial, industrial and high traffic areas. Heavy duty edging provides the ultimate strength and rigidity. Applications include asphalt and gravel retention in driveways, paths, and maintenance strips, as well as bed divisions and mulch retention in high traffic areas. 72" radius is possible.



ELITE-EDGE

A premium blend of polyethylene gives this lawn edging its superior flexibility, strength and resistance to weathering. Elite - Edge features a height of 5" from top to bottom a longer V-lip to help prevent frost heave and a 1" round top bead. Each 20ft section weighs 6 lbs.

ITEM #	PACKAGING	DESCRIPTION
PE6A	5 pieces/bundle (100ft) 4 Steel Stakes per piece 1 Connector per piece	Lawn Edging 20ft sections 1" Round Top Bead 5" Tall, 6.0 lbs per strip

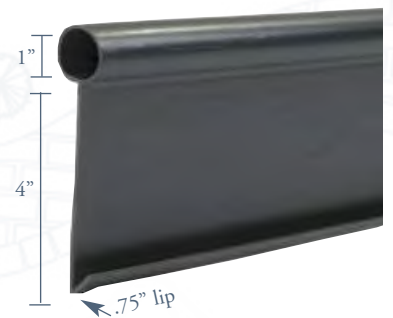

PLASTIC CONNECTORS



PLASTIC STAKES



PLASTIC CORNER CONNECTOR



EDGE-FLEX

A lighter version of Elite-Edge but still features a premium blend of polyethylene giving this lawn edging the same superior flexibility, strength, and resistance to weathering. Flex-Edge features a height of 5" from top to bottom, a 1" round top bead and a standard V-lip. Each 20ft section weighs 5 lbs.

ITEM #
PE5STD

PACKAGING
5 pieces/bundle (100ft)
4 Steel Stakes per piece
1 Connector per piece

DESCRIPTION
Lawn Edging 20ft sections
1" Round Top Bead
5" Tall, 5.0 lbs per strip

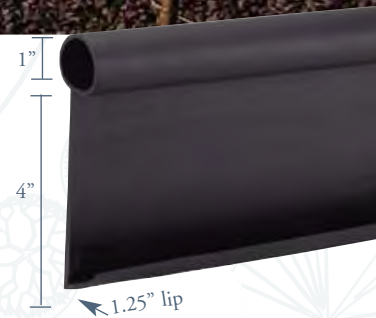

HI-TEST

A premium blend of polyethylene which features a unique corrugated side baffle. The extra-heavy top bead withstands abuse and sun exposure. Each 5" x 20ft section weighs 7 lbs.

ITEM #
PE7HT

PACKAGING
5 pieces/bundle (100ft)
1 Connector per piece
(25 Connectors per box)

DESCRIPTION
Lawn Edging 20ft sections
1" Round Top Bead
5" Tall, 7.0 lbs per strip





A18RPR

SURE-LOC REVERSIBLE ALUMINUM PAVER EDGING

will give your next paver brick project the strength and longevity it deserves. Sure-loc paver restraints give you the durability of aluminum, while allowing for design freedom.

You can achieve rigid straight runs, free flowing curves, and sharp corners without any tools. Sections join together with included hardware and stake into the ground with standard landscaping spikes to ensure a solid foundation for your project.

QUALITY FEATURES:

- Aluminum will not rust, rot, or become brittle.
- Non-overlapping joints minimize wasted material.
- Design allows for standard and reverse installation.
- Edging is completely unseen once installed.
- Straight runs, curves, and corners can be made without tools.

STEEL SPIKES



10" spiral non-galvanized spikes available in 50 lb boxes.

Sturdy Locking System



SIZE INFORMATION:

- Length:** 8'- 4" (2.5 m)
- Height:** 1-3/8" (3.5 cm)
- Thickness:** 1/8" (3.2 mm)
- Flange:** 1-1/4" x 4" (3.2 x 10.2 cm)
- Finish:** Natural Aluminum
- Feet Per Box:** 250 ft



A18158M

STANDARD HEIGHT COMMERCIAL PAVER RESTRAINTS

Durable extruded 6063 alloy aluminum is used in this strong yet flexible restraint that can create 90 degree angles without cutting. The joints do not overlap creating a seamless connection and allows for no loss of material. The V-notch base allows for easy installation for both straight and curvilinear runs. The perfect choice for the serious professional.

SIZE INFORMATION:

Length: 8 ft (2.4 M)	Thickness: 1/8" (3.2mm)
Height: 1 5/8" (41.3 mm)	Feet per box: 160 ft (20 sections)
Flange (Base Width): 1 1/8" (28.6 mm)	Included Connectors: 1/section (20/bx)

A18188M

LOW PROFILE COMMERCIAL PAVER RESTRAINTS

The same great features as our standard height paver restraint but with a lower profile. This is an ideal restraint for architectural hardscape stones such as flagstone, bluestone, granite and more.

SIZE INFORMATION:

Length: 8 ft (2.4 M)	Thickness: 1/8" (3.2mm)
Height: 1 1/8" (28.6 mm)	Feet per box: 160 ft (20 sections)
Flange (Base Width): 1 1/8" (28.6 mm)	Included Connectors: 1/section (20/bx)

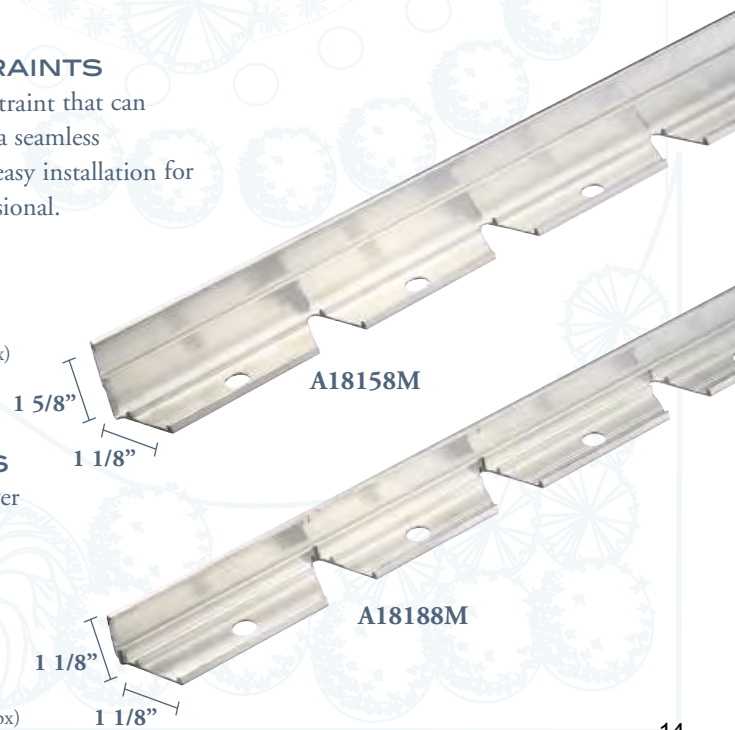



A18258M

SURE-LOC HIGH DEPTH COMMERCIAL ALUMINUM PAVER EDGING

Durable extruded 6063 alloy aluminum is used in this strong yet flexible restraint. It has all the same great features as our Standard Height and Low Profile commercial paver restraints but with a 2.5" height. This is the ideal restraint for when extra depth is required.

SIZE INFORMATION:

- Length:** 8' (2.4 m)
- Height:** 2.5" (63 mm)
- Thickness:** 1/8" (3.2 mm)
- Flange:** 2" (51 mm)
- Finish:** Natural Aluminum
- Feet Per Box:** 160 ft (20 sections)
- Included Connectors:** 1/section (20/box)

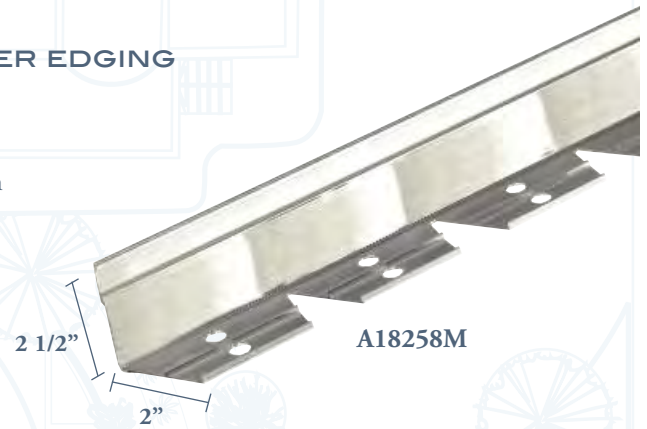

A36438M

SURE-LOC EXTRA HIGH DEPTH COMMERCIAL ALUMINUM PAVER EDGING

Durable extruded 6063 alloy aluminum is used in this strong yet flexible restraint. This is our tallest edging available, measuring 3/16" x 4" x 3" x 8'. This is the ideal restraint for when extra depth is required.

SIZE INFORMATION:

- Length:** 8' (2.4 m)
- Height:** 4" (10.16 cm)
- Thickness:** 3/16" (4.76 mm)
- Flange:** 3" (76.2 mm)
- Finish:** Natural Aluminum
- Feet Per Box:** 80 ft (10 sections)
- Included Connectors:** 1/section (10/box)

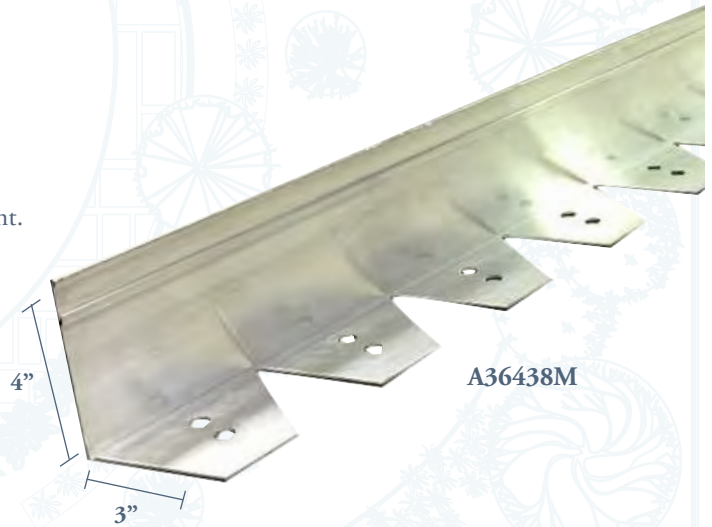

ALUMINUM PAVER RESTRAINTS

"The perfect choice for home owners and pros alike."



A1838M48

E-Z EDGE ALUMINUM PAVER RESTRAINTS

This Aluminum paver edging kit is perfect for sidewalks, patios and even driveway installations. The 1 3/8" tall L shaped profile can be installed with horizontal anchoring tabs adjacent to or underneath the pavers. It will not rust or rot and is unaffected in hot climates. Conveniently packaged in a 48ft kit which includes 8 pieces of edging and 24 spikes.

SIZE INFORMATION:

Length: 6 ft (1.8 M)

Height: 1 3/8" (35 mm)

Flange (Base Width): 1 1/8" (28.6 mm)

Thickness: 1/8" (3.2mm)

Feet per box: 48 ft/ 14.6 M (8 sections)

Included Spikes: 24 per box





P36FPE
FLEXIBLE PLASTIC PAVER RESTRAINTS

Requires no cutting for curves. Suitable for both straight and radius installations.

SIZE INFORMATION:

Length: 7' 5"
Height: 1.75" (4.45 cm)
Thickness: 3/16"
Feet per box: 75 ft



P18PE
HEAVY DUTY PLASTIC PAVER RESTRAINTS

Just one piece does both straight lines and curves.
 Extra wide base for increased stability.

SIZE INFORMATION:

Length: 8' (243.84 m) **Width:** 2.5" (6.35 cm)
Height: 1.75" (4.45 mm) **Thickness:** 3/16"
Foot: 3" (7.62 mm) **Feet Per Box:** 160 ft

MARKETING MATERIALS

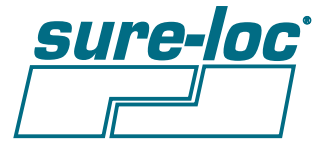

Marketing materials are available to help boost your sales.
Be sure to ask about them when ordering.

CATALOGS

Hard copies or electronic PDF



COUNTER TOP CATALOG HOLDERS

8.5" x 11" cardboard rack

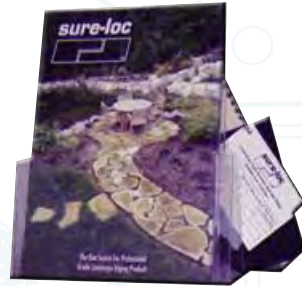

INDOOR/ OUTDOOR BANNERS

2' x 4' vinyl banners



EDGING SAMPLES DISPLAY BOARD

24" x 24" corrugated PVC indoor/outdoor sign w/ edging samples attached



NOTE PADS

5.5" x 8.5" pads



EDGING DISPLAY RACKS

Holds up to 60 pcs alum edge



For more information on
BECOMING A DISTRIBUTOR
of Sure-loc edging, call us at 1-800-787-3562 , or visit:
www.surelocedging.com/distributor

EZ-Edge:
6ft pcs

Crisp-Edge:
8ft pcs



DISTRIBUTED BY:

www.surelocedging.com

info@surelocedging.com

494 E. 64th Street

Holland, MI 49423

1.800.787.3562

Local: 616.392.3209

Fax: 616.392.5134