

BUNDUAWN

MANUAL

The **BUNDUAWN**



TO GET THE FULL BENEFIT OF YOUR GUARANTEES AND WARRANTIES, PLEASE READ THE MANUAL IN ITS ENTIRETY

The BunduAwn standard sizes are 2.45, 2.75 and 2.95 m, which is the length of the back plates.

You can order a custom sized awn of up to 4m long.

If you already have a BunduTop installed and want to mount your awning to the tent, you will purchase a 2.45.

The top of the awn is covered with an aluminised spray which reflects heat away and we have found a 3-5 degree difference in temperature when tested.

The awning weighs about 20 kgs.

Open one side of the awning first, and then the second. Opening both at the same time will result in damage.

The 360 awn has been designed to not need support poles.

The L shapes ALL need an additional pole to strengthen the design.

We do, however, suggest that you tie the awning down or close it up in poor weather conditions or if you will be absent from your campsite.

The awning works with five to six arms which, when open, allows coverage of two or three sides of your vehicle.

PLEASE NOTE that when using it for the first time, that the canvas can be stiff.

It gets coated with various resins to ensure its longevity and UV qualities, so when first operating the canvas has no "memory" of how to fold.

After a couple of uses, the canvas will evolve a "memory" of how to fold and the folding will become neater and easier as time passes.

The initial folding process will seem stiff but with time it will ease into its shape and fold neatly.

**DO NOT OPEN BOTH ARMS AT THE SAME TIME
AS THIS WILL RESULT IN DAMAGE**

INCLUDES

It boasts:

- Manual operation
- Shade awning around all three sides of the the vehicle.
- Additional lifter arms add 500mm of drop for increased water run off
- Aluminised to reflect heat away
- Cool even in direct sunlight
- 2.45m, 2.75 and 2.95m options
- Full aluminium construction
- No hot air gets trapped underneath

This awning boasts a large surface area and custom lengths.

EXTRAS

Our side panels are manufactured in 4 styles.

- A Plain Canvas Side Panel
- A Canvas Side Panel with a window
- A Canvas Side Panel with a door
- A Mesh Side Panel

The Window is the same as what can be found in a standard BunduTop, with a mesh panel which can be zipped closed.

The Door is an upside down L shape that simply zips open.

PLEASE NOTE that our awns were not designed to be closed into rooms, so if you do intend to close up all sides of the awning you do need to purchase support poles for each arm to help carry the weight.

We also recommend tying the ropes down when you have installed the support poles to give the structure as much support as possible.

PROS & CONS

Pros:

- Aluminised coating reflects heat away
- Lightweight and easy to handle
- Offers a huge surface area for more shade
- Offers additional lifter arms for an increased angle that facilitates water run off.

Cons:

- You have to fold the awning correctly
- They have to be tied down in bad weather due to the large surface area

**PLEASE TIE DOWN THE ROPES IN BAD WEATHER
OR WHEN LEAVING THE AWN UNATTENDED**

VARIOUS PROFILES

The Standard 360

We call this awn the 360 because it wraps around your vehicle.

It comes in a 2.45, 2.75 and a 2.95 size.

Each arm has guy ropes to tie down in poor weather.

We HIGHLY recommend this profile, since the design works in triangles.

The forces spread over the triangle design gives it more rigidity and strength.

- 2.45 fits Imagine Comfortvan
- 2.95 fits Tuffcats Caravan

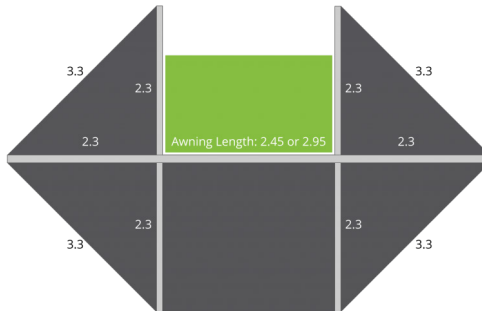

The Standard L-Shape 270

We call this awn the 270 L Shape because of its obvious shape.

It comes in a 2.45, 2.75 and a 2.95 size.

The front left arm has a support pole to give additional support since the triangular structure has been compromised.

Each arm has guy ropes to tie down in poor weather.

- 2.45 fits Afrispoor Cheetah
- 2.45 fits Conqueror Companion
- 2.95 fits Conqueror Commander

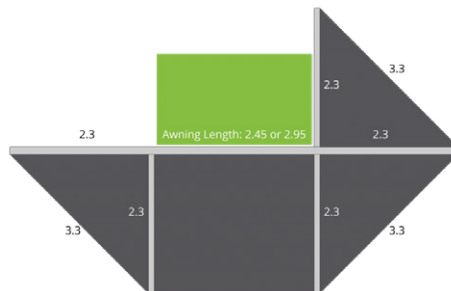

The L-Shape 270 Square Back

We call this awn the 270 L Shape Square back because of its obvious shape.

It has an additional triangle stitched in to make it square at the back.

It comes in a 2.45, 2.75 and a 2.95 size.

The front left arm has a support pole to give additional support since the triangular structure has been compromised.

Each arm has guy ropes to tie down in poor weather.

- 2.45 fits Afrispoor Cheetah

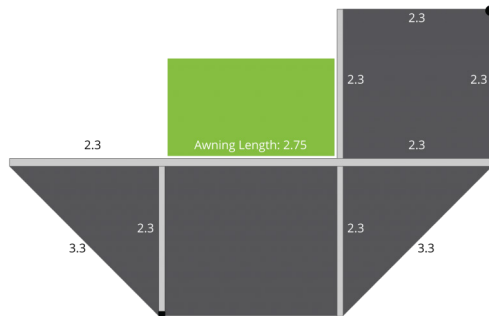

WEIGHTS

| | | |
|--|--------------|----------------|
| Half Wing (new, 4 arm version) Australia & USA Only | 2.45m | 19 Kg |
| L Shaped 2.45 + pole | 2.45m | 22 Kg |
| L Shaped 2.95 + pole | 2.95m | 24 Kg |
| L Shaped Squareback 2.75 (Companion) | 2.75m | 23 Kg |
| L Shaped Squareback 2.45 | 2.45m | 22 Kg |
| 2.45 360 (3 sided) | 2.45m | 23 Kg |
| 2.95 360 (3 sided) | 2.95m | 25.5 Kg |

HOW DOES IT WORK?

The awning works with five to six arms which, when open, allows coverage of 2 or 3 sides of your vehicle. The arms work in a triangular force which gives the awning more strength. By covering three sides the triangular structure is complete and gives additional structural support.

On the L Shape awns this triangular structure is absent, which is why you need to have a support pole.

When each arm is opened, another small arm situated on top of the main arm, pops up and provides additional height to the slope of the roof to give better water drainage and prevents large pockets of water collecting on top of your awning.

The bag of the awning, when open, closes the gap between your vehicle and the awning to prevent water running down the side of your vehicle. It is essentially a gutter while your awning is open.

Ensure the awn is taut for maximum water run off.

PLEASE NOTE that if you open the awning both arms should not be opened at the same time as this will result in damage. Open one arm and then the other. It does not matter which arm is opened first as long as they are not both opened at the same time.

When closing the awn it is better to fold the awn than to roll it as it then fits better in the bag and does not put unnecessary strain on the zip on the bag.

Also check that the lifter arms lower properly and does not hook on anything.

Our awnings have a one year mechanical warranty, which does not cover user error.

HOW DO I FIT THE AWNING MYSELF?

When installing the awning, we advise that there is no more than a 0.5m unsupported overhang.

You can order brackets with your awn order. They have been made longer than necessary so that you can adjust the height of your awning.

When installing the awning make sure that you have support running from the ends of the awning if the mounting brackets are further than 500mm from the ends of the awning.

REGULAR FITMENT:

Fit your T brackets to your vehicle. Fit the awning to the brackets. The awning can be bolted on with a minimum of 4, preferably 6 bolts.

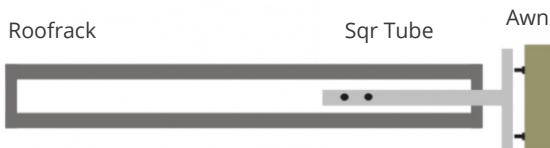

FLEXIBLE FITMENT:

When doing a fitment for a more flexible awn:

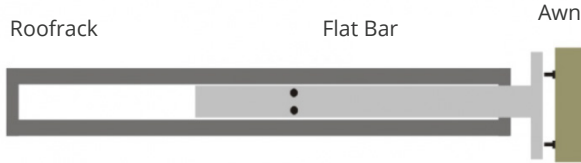

On longer awnings, or awnings mounted to both a cab and a canopy the brackets need to be able to flex more due to the cab and the canopy flexing independently.

We also recommend fitting flexible brackets on custom longer length awns to accommodate more flexibility.

INSTALLING THE AWN:

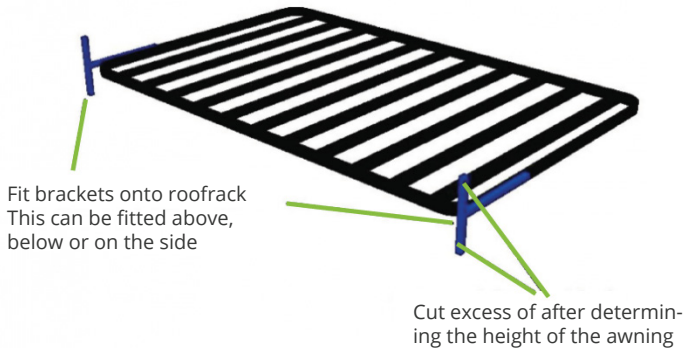

- Fit your brackets to your vehicle.
- Fit the awning to the brackets.
- The awning can be bolted on with a minimum of 4 (on the flexible brackets), preferably 6 bolts.

Bolt awning to brackets

The brackets may not be bolted more than 500mm from the ends of awning



- Arms should be more or less 90° with your roofrack.
- Hook the lead rope onto your roofrack and tighten at the cam buckle.

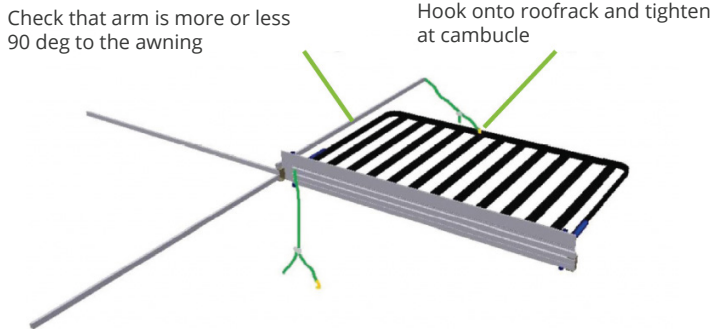

- Open the other arm of your awning and again hook onto roof rack and tighten at cam buckle.
- The canvas of the awning essentially becomes part of the structure, so a taut awning is advised.

Both webbing straps must be tightened so that the awning is tight

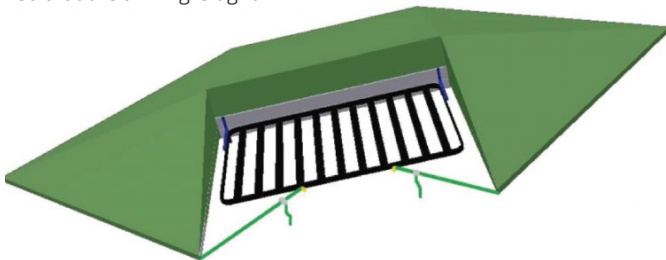

- We advise tying the awning down in bad weather.

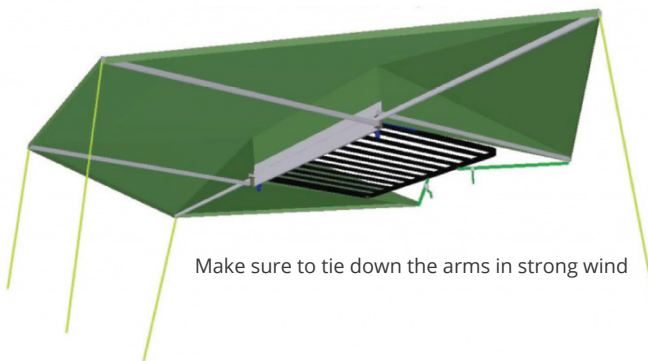

- When adding tent poles, drill a hole at the tip of the arm to slot the top of the arm in.

TO CLOSE THE AWNING FOLLOW THE OPENING PROCEDURE IN REVERSE.

The better you fold the canvas, the easier it will be to close the zip. Fold the first arm UNDER the canvas so that the 2 arms are flush with the backing plate.

The fitment procedure for our awnings are all the same, so should your awn look different than the one in the manual please note that the same principles apply.

QUICK TIP: FOLD THE CANVAS RATHER THAN ROLLING IT UP AS THIS MAKES IT EASIER TO ZIP THE BAG CLOSED

FITTING THE AWNING TO A BUNDUTOP

The brackets to mount to a BunduTop differs from the brackets used for other fitments.

Apart from this difference the mounting procedure is exactly the same.

ONLY 2.45 awnings can be mounted onto the BunduTop.

The 2.95 awning will have too much of an overhang.

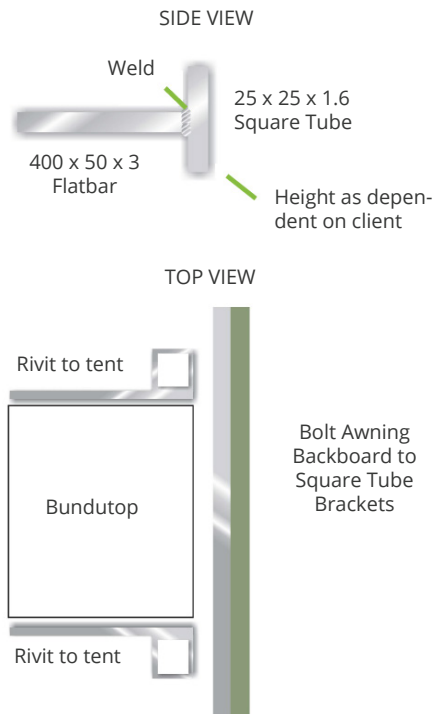

NOT TO SCALE

FAQ:

My awning seems flimsy, especially the L-shape?

The awning is manufactured to be flexible. If it seems flimsy, tighten the lead ropes until it is taut. The arms can overcam slightly to ensure that you can tighten it to tautness

The guy on the video closes it really fast, I can't seem to close my awning that easily?

The guy on the video is very tall. After a few practice runs you should be able to close it just as fast. The trick to closing the BunduAwn is that the arm should go UNDER the canvas.

You will see when he has lined up the arms from one side he lifts the bulk of the canvas over it, and repeats with the other side. This way the arms of the awning are flush with the back plate.

After that it is as simple as FOLDING up the canvas (rather than rolling, which makes it bulky in the bag) and strapping it down firmly before closing the bag.

What is it made from?

The awning is full aluminium construction and a durable RipTech canvas with a reflective surface.

Can I fit the awning myself?

Yes.

It is not heavy but it is an awkward shape and will need 2 people to handle.

Can it be fitted to my caravan or off road trailer like on the pictures on the website?

It can absolutely be fitted to any vehicle. We do advise that if you have it fitted to either a caravan or off road trailer that you arrange to have their agents do the fitment. This is because the various caravans/trailers have different internal structures.

It will be best to discuss the fitment with them as they are aware where the trailer/caravan has load bearing structural support etc.

I measured my roof rack and I need a size in-between?

The 2.45 and the 2.95 awns cover most vehicle types. You can choose either one to best suit your needs.

The BunduAwn doesn't have supporting poles, can you provide me with some when I place my order?

Since introducing new profiles we have added extendable poles to our products list.

Should you need to order additional tent poles you are welcome to contact us.



Can I add additional patched/loops and D-rings to strengthen my awning?

Adding any additional strengtheners are not necessary. Our products are designed to be lightweight but strong and durable and we offer services and repairs for your product for years to come.

I don't like the color of the awning, can I order another color?

Unfortunately we don't carry various stock. We have decided on manufacturing the awning a Olive Green and Sand only as most camping gear which utilizes canvas also comes in these colors.

This way the awning color will be the same as all the other canvas products you may already have. The top of the material is also sprayed with an aluminised paint which directly reflects sunlight away.

Will the shape of the awning affect my fuel consumption?

If it does it is indiscernible. We have not noticed any increase in fuel consumption over various vehicle types.

My awning bag isn't closing properly, it is too small.

The awn bag has been designed to be very snug - this reduces the amount of friction on the awn inside and will ensure that it lasts longer.

Do not force the lifter arms into a flat position as this will cause damage in the long run. By using the correct folding method the lifter arms will still protrude a little at the top.

When you close the bag it will fold them down further (but not flat) without causing damage.



**THE GUARANTEES AND WARRANTIES
DO NOT COVER USER ERROR**

CONTACT US

By phoning the office, Front Desk can follow up on all calls and make sure they are attended to.

SOUTH AFRICA

BunduTec

Front Desk

Tel: +27 6 3782 7667

Email: info@bundutec.co.za

AUSTRALIA

Bundutec Australia

Tel: +61 414 500 430

Email: sales@bundutec.com.au

UNITED ARAB EMIRATES

The Great White

Tel: +97 15 0350 2735

Email: hello@tgw.ae | mksbusinesswork@gmail.com

EUROPE & UNITED KINGDOM

Tuff-Trek Ltd

Tel: +44 078 6329 5172

Email: dara@tuff-trek.com

KENYA

Alan Brooks

Tel: +25 47 4363 4921

Email: brooks.nairobi@gmail.com

NAMIBIA

Offroad Center Windhoek

Tel: +26 4 6123 7532

Email: offroad@afol.com.na

Bushwhackers Campworld Swakopmund

Tel: +26 4 6440 0396

Email: swakop@nambush.com

Bushwhackers Windhoek

Tel: +26 46 125 8760

Email: simon@nambush.com

UNITED STATES OF AMERICA

BundutecUSA,

Email: rory@bundutecusa.com

Tel: +1 319-234-0071