

50Hz IS Performance



WATER PUMP
KUANG CHUAN

IS

SINGLE STAGE BACK PULL-OUT END SUCTION CENTRIFUGAL PUMP

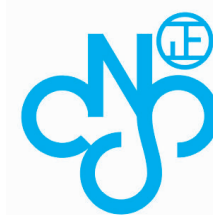
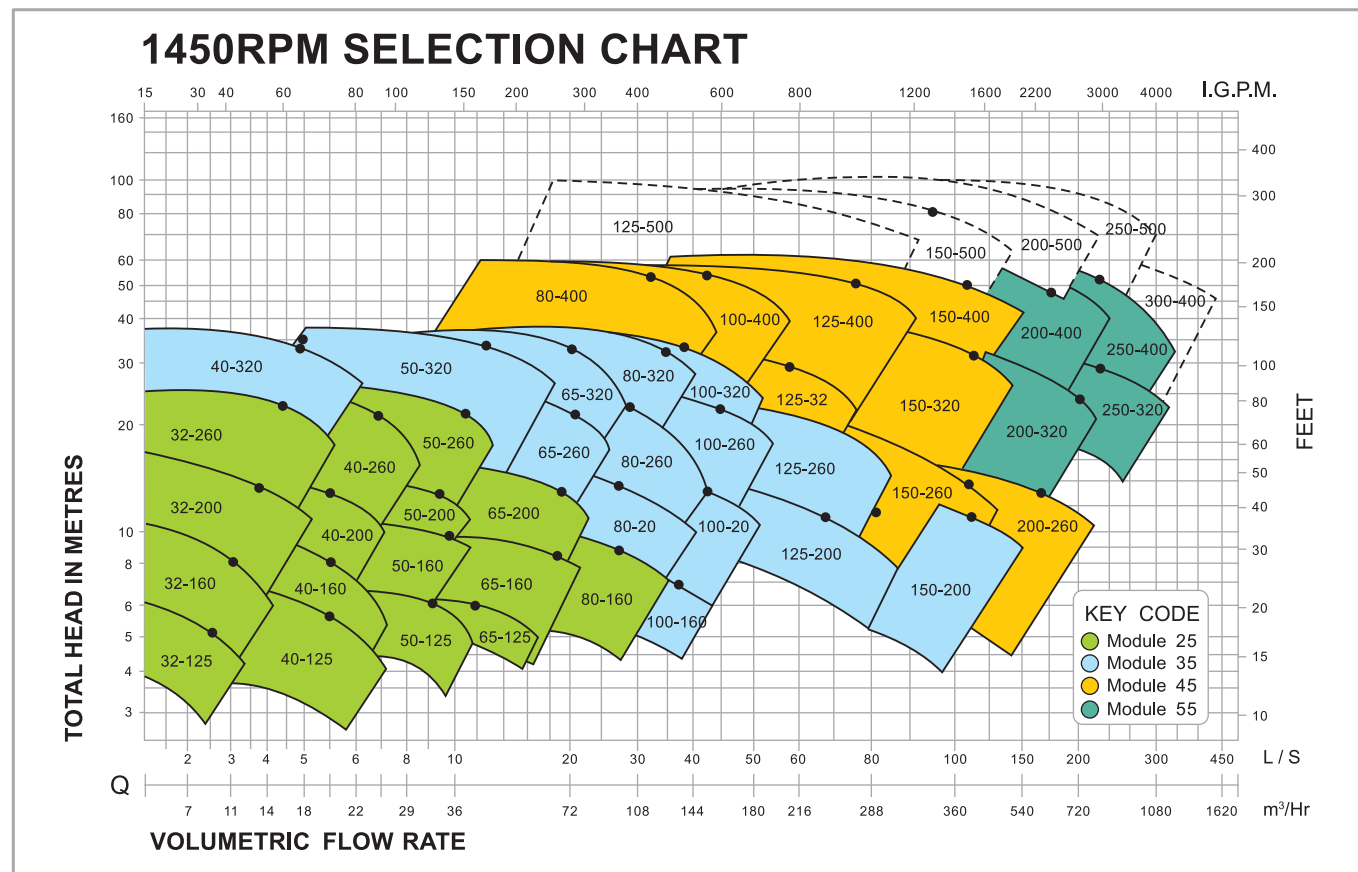
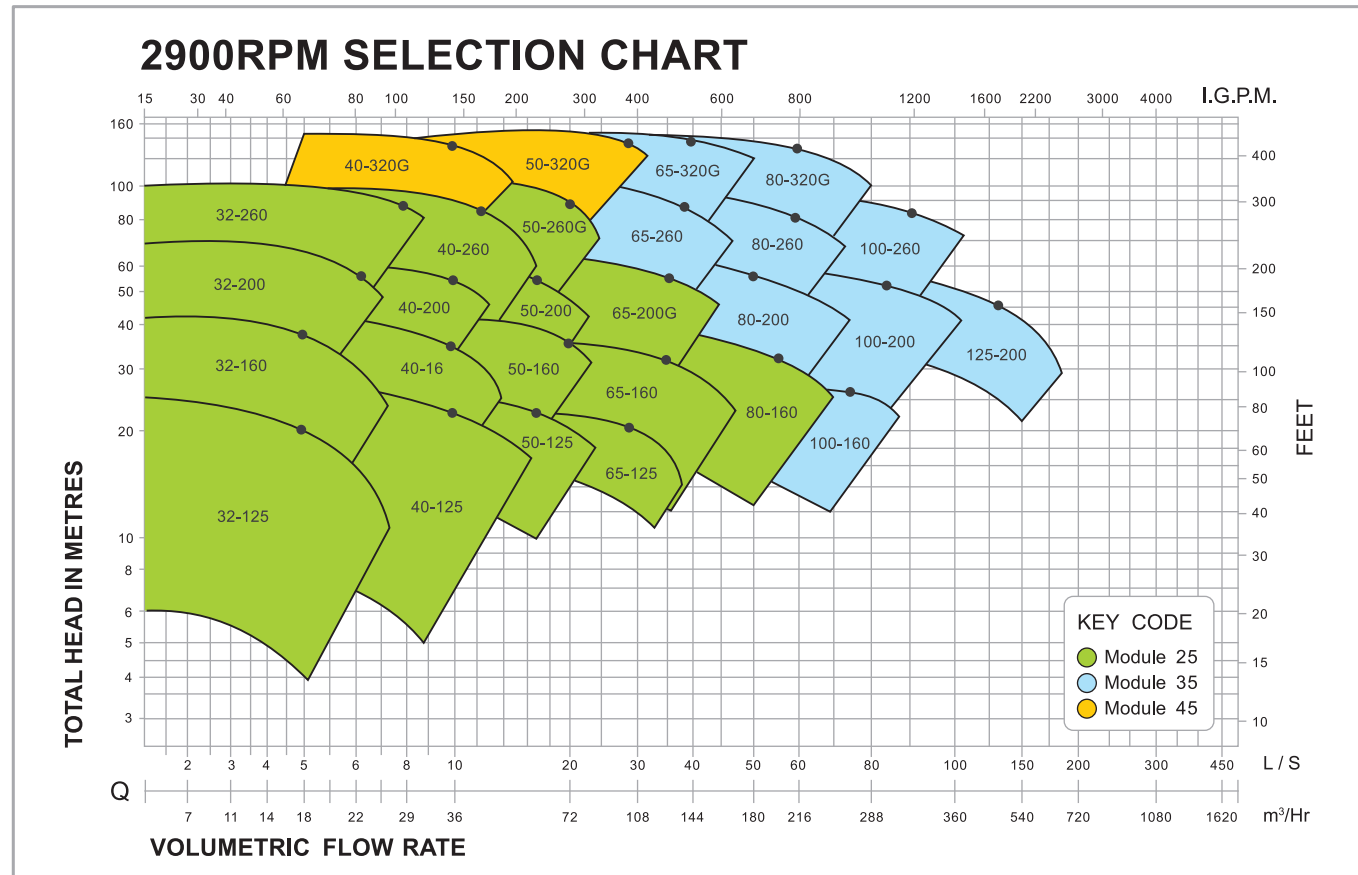

台正字7377



KUANG CHUAN PUMP ENTERPRISES CO., LTD.

IS series End suction centrifugal pump

Range from 32mm to 250mm discharge

The IS pumps offers users many advantages over equivalent pumps, because the range incorporates a number of features that improve reliability & performance, while simplifying maintenance and spare parts inventory.

The Pumps has a back pull-out design, and when a suitable spacer coupling is fitted to a direct coupled unit, the casing and motor can remain in position while all other pump parts can be removed for simple and quick maintenance.

Design

Performance and dimension referring to the European standard BS EN733/DIN24255

Structure

Horizontal, Axial End suction, Single-Stage, Single Suction, Volute Casing, Back pull-out, Centrifugal pump

Flange

Din2501/ISO7005.2 Standard, ANSI B16.5 Class 150 lb optional

Rotation

Clockwise viewing from the drive side

Pump material

Casing--cast iron standard, Nodular cast iron, Stainless Steel optional
 Impeller--Stainless Steel standard, Bronze, Cast iron optional
 Shaft--ASTM420 standard, ASTM304, ASTM316, ASTM1045 optional
 Shaft seal--Mechanical Seal standard, Gland Packing optional

Technical Information

Flow Rate(Q): 2-1100 m³/h
 Head(H) : 2-150 m
 Speed : 50Hz-1450 or 2900 rpm
 60Hz-1750 or 3500 rpm
 Temperature : -10°C-105°C
 Working Pressure: 10 Bar standard, 16 Bar optional
 Test Pressure: 15 Bar standard, 24 Bar optional

No.	Name
1	Bearing house
2	Packing or mechanical seal
3	Impeller nut
4	Volute casing
5	Impeller
6	Wear ring
7	Shaft sleeve
8	Support foot
9	Bearing
10	Shaft
11	Casing cover
12	Slinger

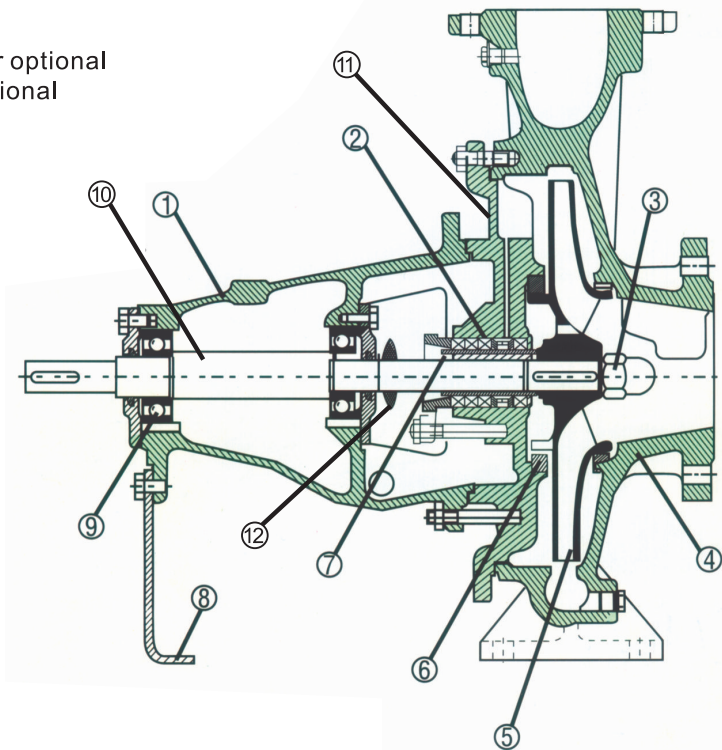

Application

- Air Conditioning
- Fire Protection
- Plumbing
- Circulating
- Transfer
- Pressure Boosting
- Cooling Towers
- Irrigation
- Water Treatment & Supply
- Chemical
- Sea Water Treatment

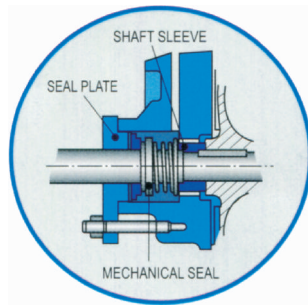

Dimensions of IS Series

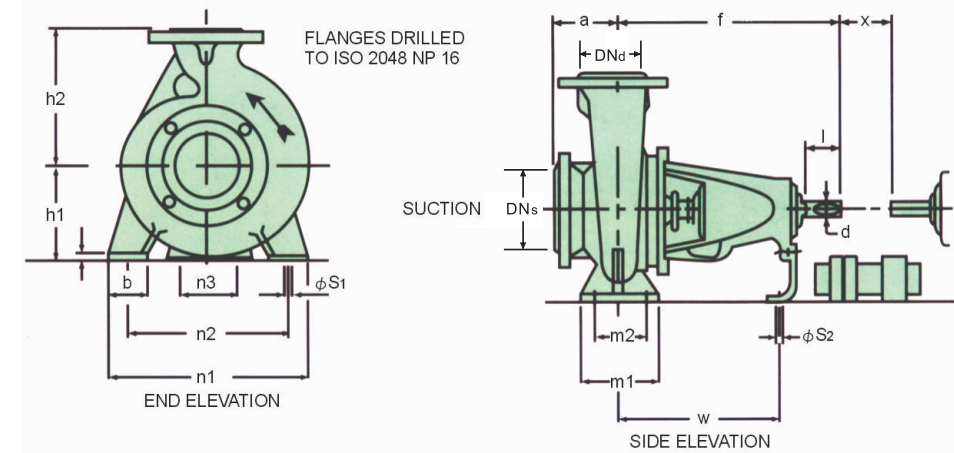

PUMP MODEL	Bearing Housing	DNs	DNd	FEET DIMENSIONS				FEET DIMENSIONS															KEY SIZE	G.W (kg)
				a	f	h1	h2	b	m1	m2	n1	n2	n3	S1	S2	w	p	x	d	l				
IS 32-125	25	50	32	80	360	112	140	50	100	70	190	140	110	12	12	285	80	80	24	50	8X7	32		
IS 32-160	25	50	32	80	360	132	160	50	100	70	240	190	110	12	12	285	80	80	24	50	8X7	40		
IS 32-200	25	50	32	80	360	160	180	50	100	70	240	190	110	12	12	285	80	80	24	50	8X7	46		
IS 40-125	25	65	40	80	360	112	140	50	100	70	210	160	110	12	12	285	80	80	24	50	8X7	35		
IS 40-160	25	65	40	80	360	132	160	50	100	70	240	190	110	12	12	285	80	80	24	50	8X7	41		
IS 40-200	25	65	40	100	360	160	180	50	100	70	265	212	110	12	12	285	100	100	24	50	8X7	49		
IS 40-260	25	65	40	100	360	180	225	65	125	95	320	250	110	12	12	285	100	100	24	50	8X7	67		
IS 50-125	25	65	50	100	360	132	160	50	100	70	240	190	110	12	12	285	100	80	24	50	8X7	40		
IS 50-160	25	65	50	100	360	160	180	50	100	70	265	212	110	12	12	285	100	100	24	50	8X7	45		
IS 50-200	25	65	50	100	360	160	200	50	100	70	265	212	110	14	12	285	100	100	24	50	8X7	50		
IS 50-260	25	65	50	100	360	180	225	65	125	95	320	250	110	14	12	285	100	100	24	50	8X7	68		
IS 65-125	25	80	65	100	360	160	180	65	125	95	280	212	110	14	12	285	100	100	24	50	8X7	45		
IS 65-160	25	80	65	100	360	160	200	65	125	95	280	212	110	14	12	285	100	100	24	50	8X7	48		
IS 65-200	25	80	65	100	470	180	225	65	125	95	320	250	100	14	12	285	100	100	24	50	8X7	55		
IS 65-260	25	80	65	100	470	200	250	80	160	120	360	280	110	16	12	370	100	120	32	80	10X8	87		
IS 65-320	35	80	65	125	360	225	280	80	160	120	400	315	110	16	12	370	120	120	32	80	10X8	105		
IS 80-160	35	100	80	125	470	180	225	65	125	95	320	250	110	14	12	285	120	120	24	50	8X7	60		
IS 80-200	25	100	80	125	470	180	250	65	125	95	345	280	110	14	12	370	125	120	32	80	10X8	75		
IS 80-260	35	100	80	125	470	223	280	80	160	120	400	315	110	16	12	370	125	120	32	80	10X8	96		
IS 80-320	35	100	80	125	470	250	315	80	160	120	400	315	110	16	12	370	125	120	32	80	10X8	115		
IS 100-200	35	125	100	125	470	200	280	80	160	120	360	280	110	16	12	370	125	120	32	80	10X8	90		
IS 100-260	35	125	100	140	470	225	280	80	160	120	400	315	110	16	12	370	140	120	32	80	10X8	110		
IS 100-320	35	125	100	140	470	250	315	80	160	120	400	315	110	16	12	370	140	120	32	80	10X8	120		
IS 100-400	45	125	100	140	530	280	355	100	200	150	500	400	110	20	12	370	140	140	32	80	12X8	183		
IS 125-260	35	150	125	140	470	250	355	80	160	120	400	315	110	20	12	370	140	120	32	80	10X8	123		
IS 125-320	45	150	125	140	530	280	355	100	200	150	500	400	110	20	12	370	140	140	42	110	12X8	156		
IS 125-400	45	150	125	140	530	315	400	100	200	150	500	400	110	20	12	370	140	140	32	80	12X8	195		
IS 150-320	45	200	150	160	530	315	400	100	200	150	550	450	140	20	12	370	160	140	42	110	12X8	198		
IS 150-400	55	200	150	160	530	315	450	100	200	150	550	450	140	20	12	370	160	140	48	110	14X9	215		
IS 150-320	55	200	150	160	670	315	400	100	200	150	550	450	140	20	12	500	160	140	48	110	14X9	210		
IS 150-320A	55A	200	150	160	670	315	450	100	200	150	550	450	140	20	12	500	160	140	55	110	16X10	250		
IS 125-500	55A	150	125	160	670	355	450	120	250	180	620	500	160	23	18	440	160	180	55	110	16X10	300		
IS 150-500	55A	200	150	160	670	400	500	120	250	180	670	550	160	23	18	440	160	180	55	110	16X10	350		
IS 200-200	55	250	200	200	550	280	280	100	200	150	500	400	140	23	18	460	200	200	48	110	14X9	185		
IS 200-250	55	250	200	180	550	315	315	100	200	150	550	450	140	23	18	320	180	140	48	110	14X9	180		
IS 200-320	55	250	200	180	550	315	315	100	200	150	550	450	140	23	18	440	180	140	48	110	14X9	186		
IS 200-400	55A	250	200	180	670	355	355	120	250	180	620	500	140	23	18	440	180	180	55	110	16X10	300		
IS 200-500	55A	250	200	180	670	400	400	120	250	180	670	550	160	23	18	440	180	180	55	110	16X10	370		
IS 250-200	55	300	250	235	670	280	280	100	200	150	550	450	160	23	18	460	235	200	48	110	14X9	220		
IS 250-250	55	300	250	225	670	315	315	100	200	150	550	450	140	23	18	460	235	200	48	110	14X9	300		
IS 250-320	55A	300	250	200	670	355	355	120	250	180	620	500	140	23	18	440	200	180	55	110	16X10	370		
IS 250-400	55A	300	250	200	670	400	400	120	250	180	670	550	160	23	18	440	200	180	55	110	16X10	400		

Pumps dimension may vary, please refer to manufacturer.