

Bucket Elevator

	A	B	C	D	E	F	G	H
C06	24"	28.625"	26.125"	16.75"	6.75"	6"	18.875"	6"
C12	36"	43.125"	43"	26.25"	9"	8"	29"	6"
C18	48"	55.25"	54.125"	34.375"	12"	9"	37.125"	8"-10"
C2412	60"	69.5"	59.875"	40.25"	12"	9"	42.875"	8"-10"
C2414	60"	73"	69"	46.375"	14"	12"	50"	8"-10"
C30	60"	78.125"	77"	52.375"	16"	12"	56.125"	10"-12"
C36	60"	89.125"	90"	58.5"	18"	12"	62.125"	12"-14"
C42	72"	116.75"	105"	69.5"	22"	14"	74"	14"-16"

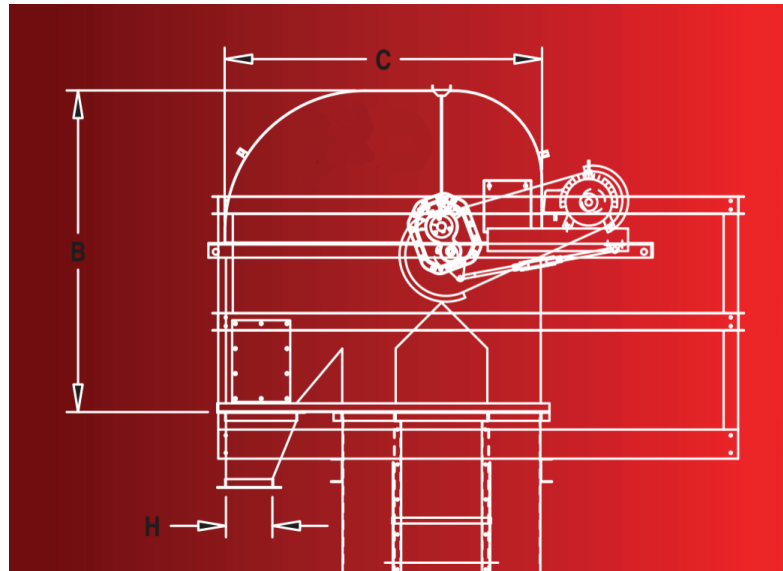
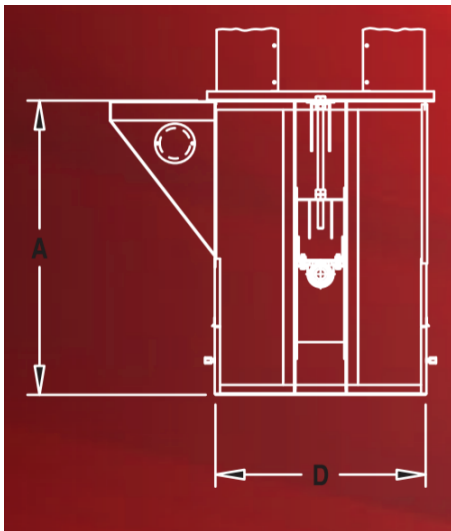
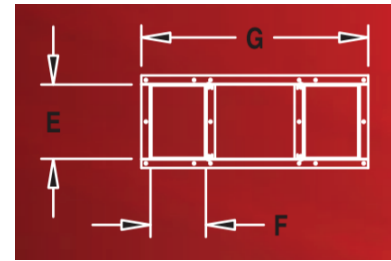

Model	C06			C12				C18			C2412			C2414		C30		C36			C42		
Series	1	2	3	1	2	3	4	1	2	3	1	2	3	1	2	1	2	1	2	3	1	2	3
BPH	150	300	600	600	900	1,200	1,500	2,400	3,000	3,500	2,400	3,000	3,500	4,000	5,000	5,000	6,000	7,000	8,000	10,000	10,000	12,000	15,000
CFH	188	375	750	750	1,125	1,500	1,875	3,000	3,750	4,375	3,000	3,750	4,375	5,000	6,250	6,250	7,500	8,750	10,000	12,500	12,500	15,000	18,700
Max Height	62'	62'	37'	93'	93'	93'	93'	114'	114'	114'	140'	140'	140'	170'	135'	200'	185'	200'	200'	195'	221'	216'	176'
Bucket Spacing	6"	3"	4"	12"	8"	6"	5"	6.75"	5.25"	4.5"	7.25"	6"	5.25"	9.5"	7.5"	10"	8.5"	10"	9"	7"	12"	10"	8"
Bucket Dimensions	4" x 3"		5" x 4"	6" x 5"				9" x 5"			9" x 5"			10" x 7"		12" x 7"		14" x 7"			16" x 8"		
RPM	115			95				78			68			68		62		62			60		
FPM	181			311				378			441			441		503		604			679		
Pulley Size	6"			12"				18"			24"			24"		30"		36"			42"		
Head Shaft	1"			1 11/16"				2 3/16"			2 15/16"			2 15/16"		2 15/16 +		3 7/16+			3 7/16+		
Boot Shaft	1"			1 3/16"				1 11/16"			1 15/16"			1 15/16"		2 7/16"		2 15/16"			3 7/16"		
Head & Boot Gauge	14G			12G				10G			10G			10G		10G		10G			Head: 10G Boot 8G		
Standard Trunking Gauge	16G			16G				14G			14G			14G		14G/12G		14G/12G			12G		

Capacities are based on dry corn at 56 lbs/bushel