



Canada GL Lighting Technology Inc.

7351 Victoria Park Ave, Unit 3, Markham, ON, Canada, L3R 3A5
T: 905-604-1000 | F: 1-866-756-3987 | sales@gl-light.ca | www.gl-light.ca

GL 150W/180W/200W/220W

Shoebox LED Area Light/Parking Lot Light



Motion Sensor



Photocell Sensor



Features

- Power Factor: ≥ 0.95
- LED Chip: SMD 3030
- CRI: $R_a \geq 70$
- 0-10V Dimming, Motion sensor & Daynight sensor, optional.
- Material: Aluminum alloy + PC optics lens
- Finish color: dark bronze
- Working Temperature: $-40^{\circ}\text{F} \sim 122^{\circ}\text{F}$ ($-35^{\circ}\text{C} - 50^{\circ}\text{C}$)
- Lifespan: > 54000 hours (@ $T_c = 176^{\circ}\text{F}$)
- Total Harmonic Distortion: 15%
- AC120-AC347V



Canada GL Lighting Technology Inc.

7351 Victoria Park Ave, Unit 3, Markham, ON, Canada, L3R 3A5
T: 905-604-1000 | F: 1-866-756-3987 | sales@gl-light.ca | www.gl-light.ca

Application

Parking lots , plaza , shopping mall , roadway ,garden ,site & area lighting and general lighting applications.

Dimension

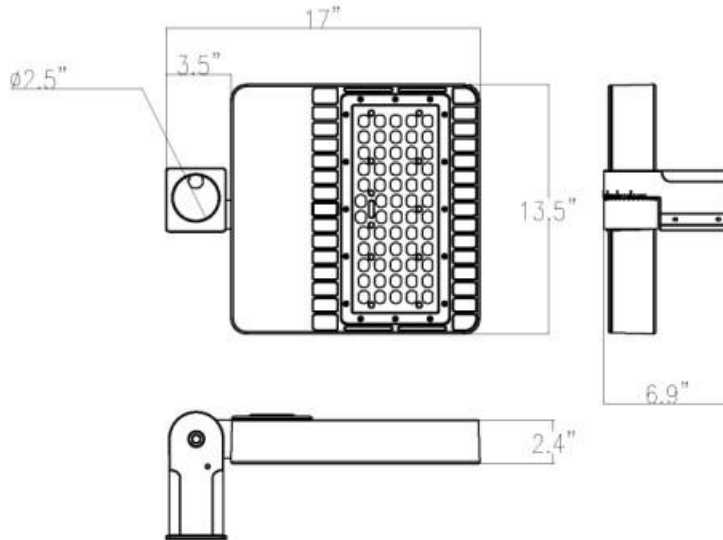

Beam Angle

Type III

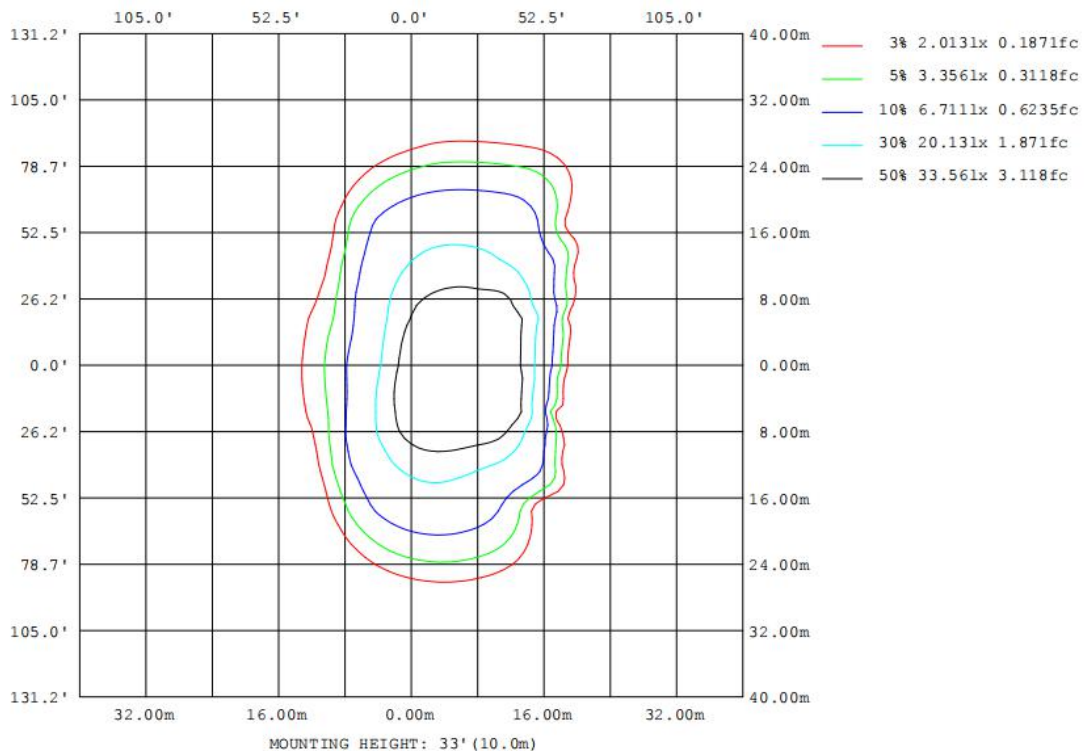



Canada GL Lighting Technology Inc.

7351 Victoria Park Ave, Unit 3, Markham, ON, Canada, L3R 3A5
T: 905-604-1000 | F: 1-866-756-3987 | sales@gl-light.ca | www.gl-light.ca

Type V

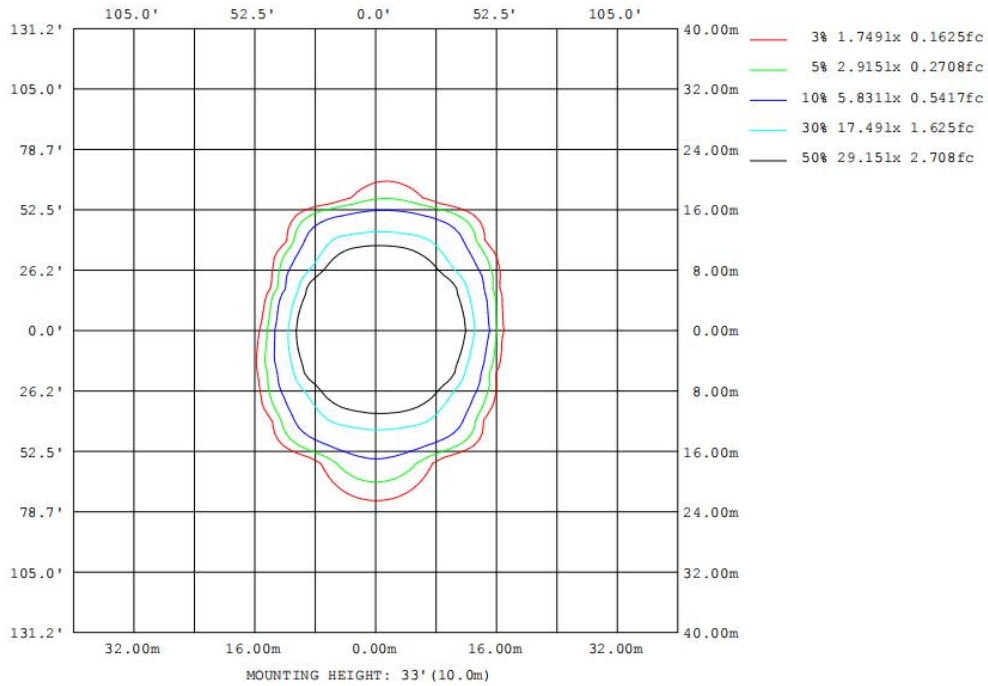

Mount Bracket

O Mount for slip fitter

S Mount for square pole

R Mount for round pole

T Trunion Mount

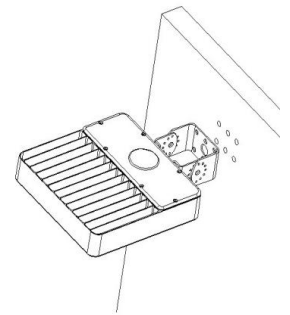
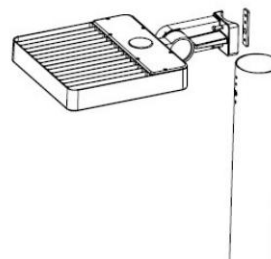
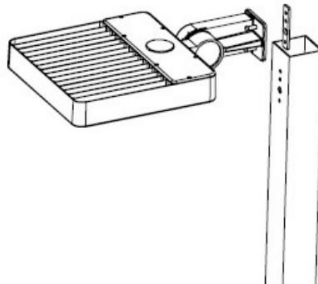
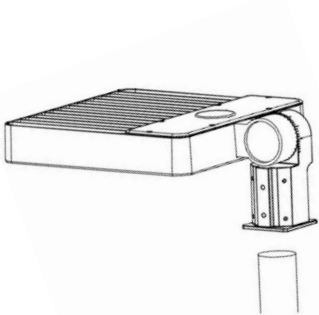



Canada GL Lighting Technology Inc.

7351 Victoria Park Ave, Unit 3, Markham, ON, Canada, L3R 3A5
T: 905-604-1000 | F: 1-866-756-3987 | sales@gl-light.ca | www.gl-light.ca

Ordering Information

Model	Wattage	CCT	Lens	Sensor	Mount	Finish
GL-PL340	150W	3000K:30	Type III	NO:Blank	Slip fitter : O	Bronze :BR
	180W	4000K:40	Type V	Photocell: P	Square pole : S	Black: BL
	200W	5000K:50		Motion: M	Round pole : R	
	220W			P+M:PM	Trunion Mount : T	

Example:

GL-PL340-200W50-TVP-OBR