



P.O. BOX 1520
6244 OLD LAGRANGE ROAD
CRESTWOOD, KY 40014
www.quanics.net

PHONE: (502) 992-8200
1-877-QUANICS
FAX: (502) 992-8249

CLASS I / NSF STD 40
WASTEWATER TREATMENT SYSTEM



OPERATION & MAINTENANCE MANUAL

MANUFACTURED
PRODUCTS
BY:

QUANICS™

FIXED FILM MEDIA
WASTEWATER TREATMENT SYSTEMS

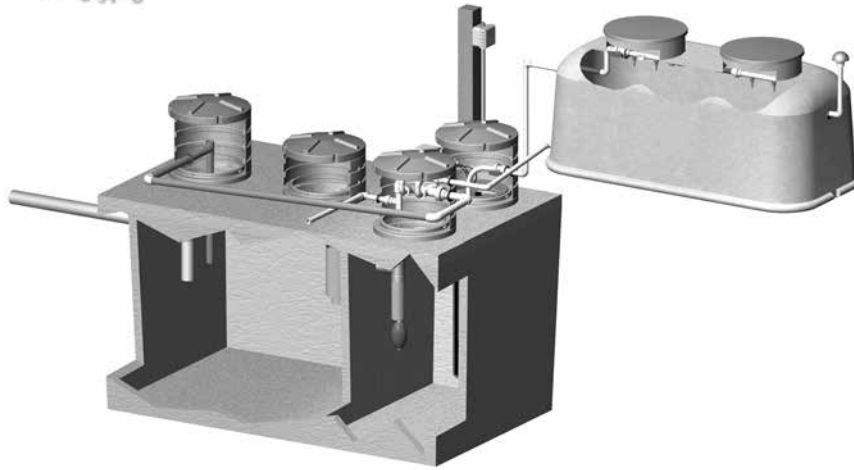

Table of Contents

INTRODUCTION	2
PROCESS DESCRIPTION	2
INSPECTION SEQUENCE	3
SERVICE INSTRUCTIONS	3
Section 1.0 Septic Tank	3
Section 2.0 A300-8" Series Effluent Filter	3
Section 3.0 Dosing Tank	4
Section 4.0 Filtered Pump Vault	4
Section 5.0 Controls/Pumps/Floats	4
Section 6.0 Treatment Module	4
Section 7.0 Recirculation Device	5
TROUBLESHOOTING GUIDE	5-6
SAFETY	6
DRAWINGS/TECHNICAL DATA	7-19
WIRING SCHEMATICS	20-21
DATA PLATES	21

INTRODUCTION

QUANICS™ is committed to becoming the best water solutions problem solver in the world. We promise to provide complete engineered water solutions using the latest technology and best products. We will provide the best technical assistance and customer service available and we will always deliver more than we promise.

In our quest to serve our market, we do not view a technology as the one and only option, but rather look to develop a wide variety of technologies that the engineer and/or end user can tailor to their individual application. Along this line, we are proud to introduce two NSF Certified treatment systems, SCAT® **AeroCell®** and SCAT **Bio-COIR®**.

Both systems operate as fixed-film media filters to treat wastewater. The patented SCAT delivery system is the same for each system only the media is different. Each media type has its own unique properties and both have been tested and listed under NSF International Standard 40 Class 1 requirements. Both systems have also been demonstrated to significantly reduce total nitrogen. The following manual will explain the differences and similarities of each system. Before reading this manual determine which system you are currently utilizing by examining the data plate attached to the system lid. Each system will be identified by name "**AeroCell**" or "**Bio-COIR**".

This manual covers the following model numbers.

AeroCell Model #'s	Bio-COIR Model #'s
ATS-SCAT-8-AC-C500	ATS-SCAT-8-BC-C500
ATS-SCAT-86-AC-C750	ATS-SCAT-86-BC-C750
ATS-SCAT-88-AC-C1000	ATS-SCAT-88-BC-C1000
ATS-SCAT-886-AC-C1250	ATS-SCAT-886-BC-C1250
ATS-SCAT-888-AC-C1500	ATS-SCAT-888-BC-C1500

We are eager to assist you with any questions or problems. Please contact **QUANICS** at 1-877-**QUANICS** to request assistance.

PROCESS DESCRIPTION

The **QUANICS AeroCell & Bio-COIR** are individual wastewater treatment systems utilizing fixed film media. The module(s) consist of a fiberglass tank(s) containing a pre-determined amount of media. Effluent is sprayed over the media utilizing specialized spray nozzles. This patented delivery system evenly distributes wastewater to achieve the desired treatment levels.

The **AeroCell** utilizes open cell foam media. The foam has a high porosity, large surface area and ease of microbial attachment that allows for loading rates up to ten times that of sand. Open cell foam has a fifteen year track record of treating wastewater to the highest quality treatment levels. The application rates for the **AeroCell** system have been carefully selected to provide optimal treatment and performance in a long lasting media.

The **Bio-COIR** utilizes a patent pending **Bio-COIR** media for treatment. The **Bio-COIR** media is composed of fibers that constitutes the thick mesocarp, or husk, of the coconut fruit. The long fibers are used for ropes, door mats etc, leaving pith tissue and short to medium length fibers as a waste which has accumulated in heaps in many third world countries. The short to medium length **Bio-COIR** fibers used in **Bio-COIR** are a lingocellulosic material. The high lignin content of these fibers results in a more durable material than other natural medias. The high lignin content of 45.84% also results in a slower degradation of the media and assures that excellent water/air ratio is maintained over a longer period of time.

In both **AeroCell & Bio-COIR** systems, pretreatment of the wastewater occurs through the use of a septic tank equipped with a **QUANICS** A300 series effluent filter on the outlet. The pretreated wastewater then moves into a dosing tank where an effluent pump doses the wastewater to the treatment module(s). The dosing of effluent occurs in short frequent doses over a 24-hour period utilizing a timed dosed control panel. Effluent is sprayed over the media through the use of specially designed helical spray nozzles that provide uniform distribution of the effluent over the entire surface area.

Once sprayed, the effluent moves via gravity down through the media where it is allowed to come into contact with beneficial microorganisms that serve to treat the effluent to NSF International Standard 40 Class 1 requirements. After passing through the full depth of media the effluent travels to the **QUANICS™** ATS-GRD-100/80/20 recirculation device. The recirculation device splits the flow and discharges 80% back into the treatment stream and 20% to the final disposal point. In periods of low flow, 100% of the treated effluent discharges back into the treatment stream.

INSPECTION SEQUENCE

All onsite wastewater treatment and dispersal systems should be inspected and maintained periodically in order to provide years of trouble free operation. The **AeroCell®** & **Bio-COIR®** systems require an inspection and minimal maintenance every 6 months. Most onsite professionals are familiar with all of the system components because they are used routinely in other systems. The following inspection sequence is recommended to determine the current operating condition of the system and what service items must be completed.

1. Locate all the system components and access openings.
2. Remove all the access lids.
3. Note the water level in the septic tank and its relationship to the top of the effluent filter.
4. Note the water level in the dosing tank and its relationship to the floats.
5. If the timer enable float is up, wait for the control panel to activate on its own time settings. Ensure the pump run time is as per design parameters. If the timer enable float is down, the pump will need to be activated manually by switching the HOA switch in the control panel to HAND.
6. While the pump is running, observe the spray nozzles in the treatment module for flow and pressure.
7. While the pump is running, observe the recirculation device for proper flow.
8. Once the current operating condition of the system is established, turn the HOA switch to the OFF position in the control panel.
9. Perform service as described in this manual.

SERVICE INSTRUCTIONS

Section 1.0 Septic Tank

The septic tank should be inspected for excessive scum and solids build up. There are several commercial devices that can be used to measure the sludge layer and determine the pumping frequency of the tank. Homemade devices can also be used to check the sludge level. No matter what you use to check these levels, the tank should be pumped when the sludge level in the bottom of the tank reaches within 12 inches of the bottom of the outlet tee of the septic tank.

PROPERTY OWNERS should be encouraged not to use excessive amounts of cleaners and bleach, which upset the digestive process in the tank. However, normal amounts of these and other common household products do not cause problems. Non-biodegradable materials such as greases, garbage disposal by-products, personal hygiene products, cigarettes, paint, chemicals and diapers should not be disposed of in the tank.

Section 2.0 Effluent Filter

Inspect the septic tank filter and clean it as needed. The length of the maintenance interval for effluent filters will vary with each individual PROPERTY OWNER. Once a filter is inspected a few times, you should be able to predict the length of the service interval. Installation and maintenance instructions are included

with each **QUANICS** product.

To clean the filter:

1. Firmly pull the filter handle and slide the cartridge out of the case.
2. While holding the cartridge over the access opening, rinse off the cartridge with fresh water, being careful to rinse all septage material back into the tank.
3. Insert the filter cartridge back in the case making sure the cartridge is properly aligned and completely inserted in the case.



Section 3.0 Dosing Tank

The dosing tank should be inspected for excessive scum and solids build up. There are several commercial devices that can be used to measure the sludge layer and determine the pumping frequency of the tank. Homemade devices can also be used to check the sludge level. No matter what you use to check these levels, the tank should be pumped when the sludge level in the bottom of the tank reaches the bottom of the filtered pump vault.

Section 4.0 Filtered Pump Vault

The filter panels on the pump vault should be inspected and cleaned during routine maintenance visits. However, the filter plates are virtually self-cleaning. The continued action of the anaerobic organisms on the filter plates causes lodged particle to disintegrate and fall to the bottom of the tank.



To clean the filter plates:

1. Completely insert the white maintenance plate behind the filter panel that is to be cleaned.
2. Remove the filter panel. Rinse the filter plates with fresh water making sure all septage is rinsed back into the tank. The filter plates should be cleaned until all slots are open and free of debris.
3. Replace the filter panel and remove the white maintenance plate. Repeat steps 1 and 2 for the second filter panel.

Section 5.0 Controls/Pump/Floats

1. Inspect the floats for proper placement and make certain they are not tangled.
2. Lift the high water alarm float to activate the alarm system to verify proper operation.
3. Open the AC-CP-S-C-T control panel outer door.
4. Activate the pump through the panel manually by moving the HOA switch to Hand.
5. The pump should begin the run and deliver effluent to the treatment module. Trip the floats to test for proper pump operation

Section 6.0 **AeroCell®** & **Bio-COIR®** Modules

1. A gray biomat on the surfaces of the media may be present and is normal. An excessive accumulation of solids on the media may indicate that the septic tank is functioning poorly due to excessive household chemicals or a lack of maintenance. Check with the **PROPERTY OWNER** about what types of materials have been discharged. As previously mentioned, excessive bleach, cleaning materials, and other chemicals can upset the septic tank. Advise the owner to restrict the use of such materials.
2. If necessary, rake or stir the upper layer(s) of treatment media. It is normal for the media to settle. It may be necessary to redistribute the treatment media to allow proper air flow. Coir media is a biodegradable

material and may require replacement every 7 to 10 years. When the **Bio-COIR** media has reduced in volume by 50%, and the effluent quality fails to meet minimum regulatory requirements, it needs to be replaced. The open cell foam media is warranted to be free from defect for 10 years. If the media shows degradation after that time and the effluent quality fails to meet minimum regulatory requirements, new media should be added. When replacing either media, make sure to compact it below the spray nozzle by approximately 4-6 inches to make certain that the spray nozzles function properly.

3. Remove the spray nozzle by unsnapping the stainless steel spring from the pipe. Clean any debris and replace them. The spray nozzle piping can be removed at the unions and cleaned with a bottle brush or water pressure if needed.



NOTE: If effluent samples are needed, a grab sample can be taken by placing the sample bottle below the out fall of the recirculation device, being careful not to touch the bottle to any contaminated surface. The effluent sample should be collected and transported according to the testing facility requirements. Effluent should be clear with a slight yellow tint and should be free from odor. Effluent results should be in accordance with NSF Standard 40 Class 1 requirements, BOD less than 25mg/L and TSS less than 30mg/L.

Section 7.0 Recirculation Device

1. Check to see if the stainless steel rod is moving up and down freely. Also, check to see if the ball float is located at the proper level. When the ball float is at its lowest position, it should be located equal to or just above the on position of the timer enable float. (**figure 1**)

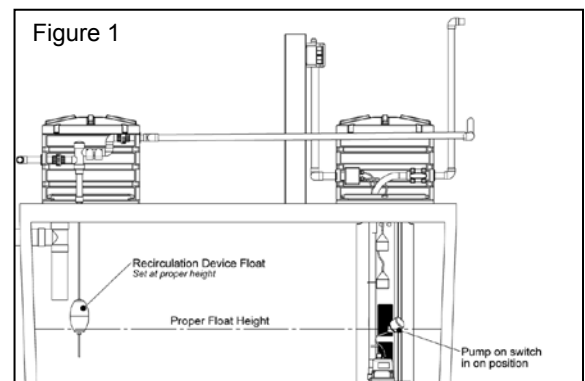

2. Check that the design recirculation rates are maintained by observing the discharge through all five out falls of the recirculation assembly. Adjust as needed by loosening the quick disconnects and leveling.

TROUBLESHOOTING GUIDE

The **AeroCell® & Bio-COIR®** systems will handle all domestic wastewater from your home. By the term wastewater we are referring to rapidly biodegradable material. To keep maintenance at a minimum level and to prevent the system from malfunctioning, the following guidelines need to be followed:

- * Since aerobic bacteria are responsible for treating the wastewater, inorganic or non-rapidly biodegradable materials should not be put into the system. Examples of improper items are: plastic products, rubber products, sanitary napkins or tampons, washcloths, cigarette butts, coffee grounds, eggshells, matches, or other non-biodegradable objects.
- * Do not dispose of cooking grease or large amounts of oil into system; instead pour it into a container and dispose of it properly.
- * To minimize pump-out frequency, limit use of garbage disposals.
- * Lint from lint catchers, hair, etc., should be disposed in the trash and not washed down the drain.
- * Water softener backwash should not be routed through the system. Another source of disposal should be used.
- * Diapers can be rinsed out in the toilet; however, do not flush cloth or disposable diapers down the toilet.
- * Large amounts of harsh chemicals, high sudsing detergents, disinfectants or any substance that kills bacteria must not be discharged into the system.

* The system will not perform to its fullest capabilities if volumetric overload is allowed to occur. This occurs whenever excessive water, above the designed flow rate, is allowed into the system. Excessive water use or leaking plumbing fixtures may cause this condition.

The **AeroCell® & Bio-COIR®** systems are very effective and reliable in the treatment of domestic wastewater. The problems outlined here occur only in a very small percentage of total installations. They can all be corrected and most be prevented.

1. Alarm condition exists:

- a. Check the breaker for the pump.
- b. If the breaker is engaged, set HOA switch to HAND to see if the pump runs.
- c. Check the nozzles to be sure they are not clogged and restricting the flow into the module.
- d. Check the timer enable float to insure that it is operating properly.
- e. Check the timer override float to insure that it is operating properly.
- f. Clean the filter panels on the filtered pump vault to assure that effluent is getting into the vault.
- g. Check the high water alarm float to see if it is stuck in the up position.

2. Excessive solids in the module:

- a. Check to see if the effluent filter cartridge has been removed.
- b. Check the septic tank to see if it appears normal. If not, check with the PROPERTY OWNER to determine what inappropriate materials might have been added to the waste stream.

3. Recirculation device is not splitting properly:

- a. Check the out falls for clogging.
- b. Check the device for level.

4. Control panel malfunction:

- a. Check all fuses and breakers.
- b. Check originating power source.
- c. Check timer setting to assure it is set according to original design parameters.

5. Effluent quality is out of design parameters:

- a. Check the septic tank to see if it needs pumping.
- b. Check the dosing tank to see if it needs pumping.
- c. Check the out-falls for contamination.
- d. Assure that proper procedures were used in taking the sample.
- e. Check water usage to insure that it is within design parameters.
- f. Check the nozzles for clogging.
- g. Check the timer setting to assure it is according to design parameters.

SAFETY

As raw wastewater may and usually does contain some level of unsafe microorganisms, proper respect and care must be given to safety. When coming into contact with raw sewage, do not fear the contact, but do take proper precautions to avoid potential danger.

Follow these simple safety precautions whenever exposed to wastewater:

* Always wash with soap and water after handling any contaminated item. The use of good bactericide

soap is strongly recommended.

- * Wear disposable rubber gloves when handling wastewater-contaminated items or chlorine tablets.
- * Always dispose of scum, rags, trash, debris, or soiled material in a proper waste container.
- * If a wastewater spill or leak occurs in a yard, flush area with plenty of clean water and disinfect. If a spill or leak occurs in the house, clean with a dilute solution of bleach.
- * Protect any injury, wound, open cut, etc. from exposure to wastewater.
- * If an illness or disease is suspected of coming from exposure to sewage, get proper medical attention immediately.
- * Report all accidents relating to sewage exposure to the proper supervisory personnel.

Follow these safety precautions when performing any excavation or construction work:

- * Follow all construction safety procedures during installation.
- * Follow electrical safety procedures during installation.
- * Fill all holes and depressions in and around the installation area; remove and dispose of all debris from installation.

TECHNICAL DATA/DRAWINGS INDEX

ATS-SCAT-8-AC-C500	8	PDS-ED-1.5	16
ATS-SCAT-86-AC-C750	8	PDS-GT-1.5	16
ATS-SCAT-88-AC-C100010	9	AC-FT-3	17
ATS-SCAT-886-AC-C1250	9	AC-JSB-4	17
ATS-SCAT-888-AC-C1500	10	AC-CP-S-C-T	18
ATS-SCAT-8-BC-C500	10	ATS-GRD-100/80/20	18
ATS-SCAT-86-BC-C750	11	ATS-GRD-100/80/20-N	18
ATS-SCAT-88-BC-C1000	11	RB-CTA-26x6	19
ATS-SCAT-886-BC-C1250	12	RB-R-26x18	19
ATS-SCAT-888-BC-C1500	12	RB-L-26	19
ATS-SCAT-6	13		
ATS-SCAT-8	13		
A300-8" Series Effluent Filter	14		
FPV-H44-4	14		
P-SE-13T	15		

500 GPD AeroCell® System

www.quanics.net/autocad.htm

ZONE		REV.		REVISIONS		DATE		APPROVED	
ZONE	REV.	DESCRIPTION	DATE	APPROVED					

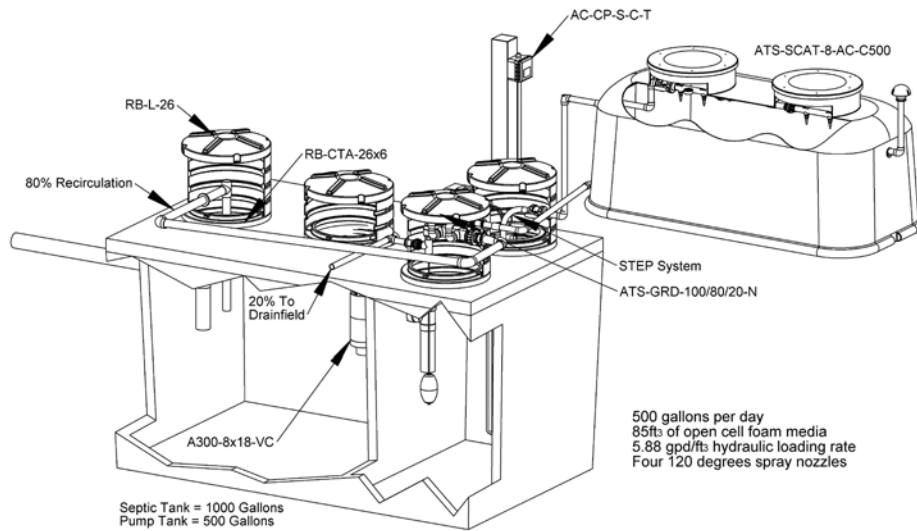

Septic Tank = 1000 Gallons
 Pump Tank = 500 Gallons
 The septic tank shall have a minimum L:W ratio of equal to or greater than one.

500 gallons per day
 85ft of open cell foam media
 5.88 gpd/ft hydraulic loading rate
 Four 120 degrees spray nozzles

Parts Included:

- ATS-SCAT-8-AC-C500
- A300-8x18-VC
- FPV-H44-4
- P-SE-13T
- PDS-ED-1.5
- PDS-GT-1.25
- PDS-GT-1.5 (2x)
- AC-FT-3
- AC-JSB-4
- AC-CP-S-C-T
- ATS-GRD-100/80/20-N
- RB-CTA-26x6 (4x)
- RB-R-26x18 (3x)
- RB-L-26 (3x)

Product(s) covered by one or more U.S. and/or International patents. Other U.S. and International patents may be pending.

DIMENSIONS ARE IN INCHES		NAME	DATE	QUANICS Incorporated	
TOLERANCES:		DRAWN	TNJ		08-08-05
FRACTIONAL ±		CHECKED	BB		08-08-05
ANGULAR: MACH ± BEND ±		ENG APPR.			
TWO PLACE DECIMAL ±		MFG APPR.			
THREE PLACE DECIMAL ±		G.A.			
MATERIAL		COMMENTS:			
NEXT ASSY	USED ON	FINISH	--		
APPLICATION	SCALE	1 : 35			
SIZE A			DWG. NO.	REV.	
			ATS-SCAT-8-AC-C500		
WEIGHT:			SHEET 1 OF 1		

750 GPD AeroCell System

www.quanics.net/autocad.htm

ZONE		REV.		REVISIONS		DATE		APPROVED	
ZONE	REV.	DESCRIPTION	DATE	APPROVED					

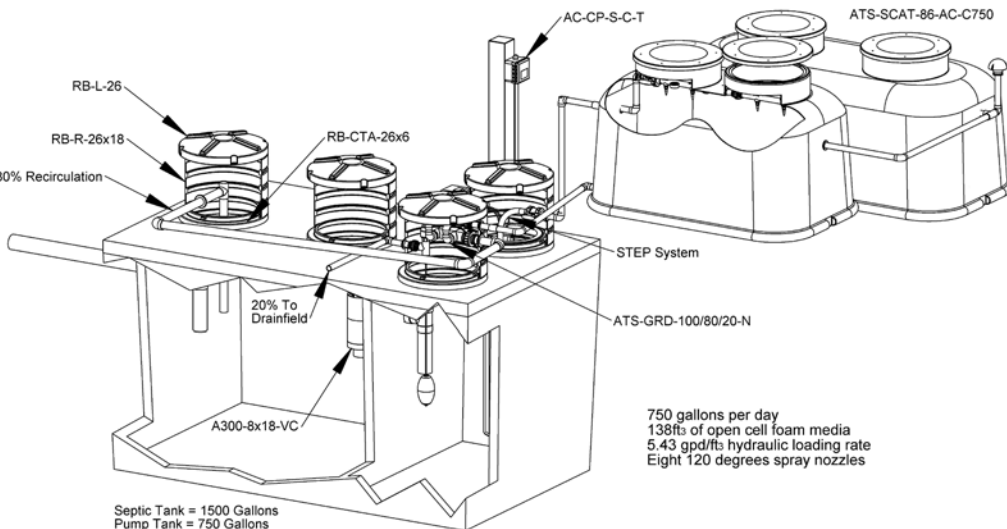

Septic Tank = 1500 Gallons
 Pump Tank = 750 Gallons
 The septic tank shall have a minimum L:W ratio of equal to or greater than one.

750 gallons per day
 138ft of open cell foam media
 5.43 gpd/ft hydraulic loading rate
 Eight 120 degrees spray nozzles

Parts Included:

- ATS-SCAT-86-AC-C750
- A300-8x18-VC
- FPV-H44-4
- P-SE-13T
- PDS-ED-1.5
- PDS-GT-1.25
- PDS-GT-1.5 (2x)
- AC-FT-3
- AC-JSB-4
- AC-CP-S-C-T
- ATS-GRD-100/80/20-N
- RB-CTA-26x6 (4x)
- RB-R-26x18 (3x)
- RB-L-26 (3x)

Product(s) covered by one or more U.S. and/or International patents. Other U.S. and International patents may be pending.

DIMENSIONS ARE IN INCHES		NAME	DATE	QUANICS Incorporated	
TOLERANCES:		DRAWN	TNJ		08-08-05
FRACTIONAL ±		CHECKED	BB		08-08-05
ANGULAR: MACH ± BEND ±		ENG APPR.			
TWO PLACE DECIMAL ±		MFG APPR.			
THREE PLACE DECIMAL ±		G.A.			
MATERIAL		COMMENTS:			
NEXT ASSY	USED ON	FINISH	--		
APPLICATION	SCALE	1 : 35			
SIZE A			DWG. NO.	REV.	
			ATS-SCAT-86-AC-C750		
WEIGHT:			SHEET 1 OF 1		

1000 GPD AeroCell® System
www.quanics.net/autocad.htm

ZONE		REV. DESCRIPTION		DATE	APPROVED

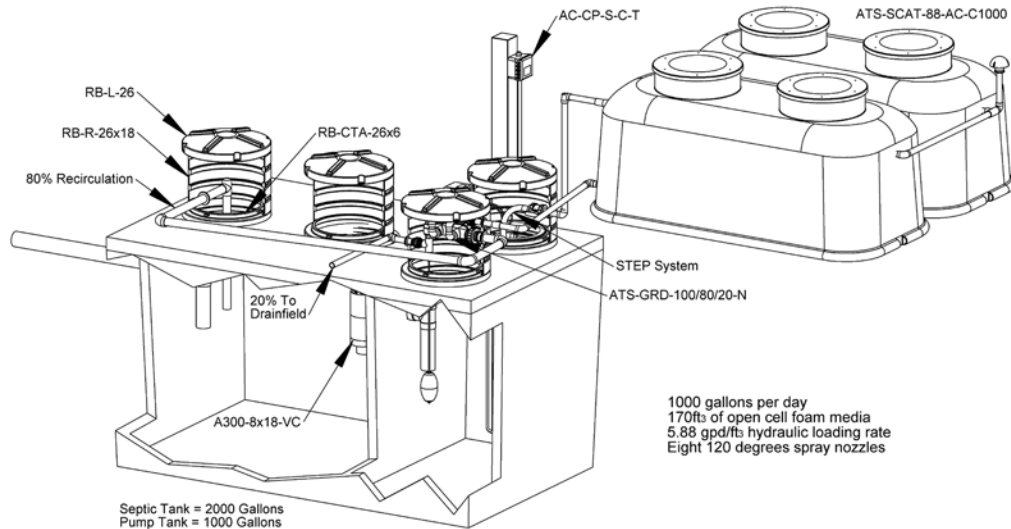

1000 gallons per day
 170lbs of open cell foam media
 5.88 gpd/fts hydraulic loading rate
 Eight 120 degrees spray nozzles

Septic Tank = 2000 Gallons
 Pump Tank = 1000 Gallons
 The septic tank shall have a minimum L:W ratio of equal to or greater than one.

Parts Included:

- ATS-SCAT-88-AC-C1000
- A300-8x18-VC
- FPV-H44-4
- P-SE-13T
- PDS-ED-1.5
- PDS-GT-1.25
- PDS-GT-1.5 (2x)
- AC-FT-3
- AC-JSB-4
- AC-CP-S-C-T
- ATS-GRD-100/80/20-N
- RB-CTA-26x6 (4x)
- RB-R-26x18 (3x)
- RB-L-26 (3x)

Product(s) covered by one or more U.S. and/or International patents. Other U.S. and International patents may be pending.

DIMENSIONS ARE IN INCHES		NAME	DATE	QUANICS Incorporated	
TOLERANCES:		DRAWN	TNJ		08-08-05
FRACTIONAL: ±		CHECKED	BB		08-08-05
ANGULAR: MACH ± BEND ±		ENG APPR:			
TWO PLACE DECIMAL ±		MFG APPR:			
THREE PLACE DECIMAL ±		Q.A.			
MATERIAL		COMMENTS:			
NEXT ASSY	USED ON	FINISH	--		
APPLICATION	SCALE	1 : 35			
SIZE		DWG. NO.	REV.		
A		ATS-SCAT-88-AC-C1000			
WEIGHT:		SHEET 1 OF 1			

1250 GPD AeroCell System
www.quanics.net/autocad.htm

ZONE		REV. DESCRIPTION		DATE	APPROVED

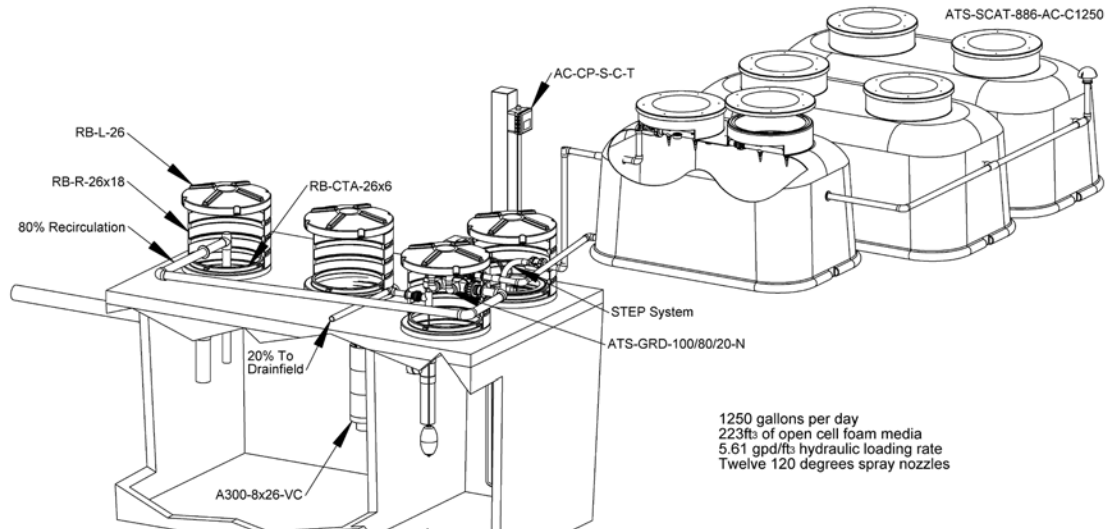

1250 gallons per day
 223lbs of open cell foam media
 5.61 gpd/fts hydraulic loading rate
 Twelve 120 degrees spray nozzles

Septic Tank = 2500 Gallons
 Pump Tank = 1250 Gallons
 The septic tank shall have a minimum L:W ratio of equal to or greater than one.

Parts Included:

- ATS-SCAT-886-AC-C1250
- A300-8x26-VC
- FPV-H44-4
- P-SE-13T
- PDS-ED-1.5
- PDS-GT-1.25
- PDS-GT-1.5 (2x)
- AC-FT-3
- AC-JSB-4
- AC-CP-S-C-T
- ATS-GRD-100/80/20-N
- RB-CTA-26x6 (4x)
- RB-R-26x18 (3x)
- RB-L-26 (3x)

Product(s) covered by one or more U.S. and/or International patents. Other U.S. and International patents may be pending.

DIMENSIONS ARE IN INCHES		NAME	DATE	QUANICS Incorporated	
TOLERANCES:		DRAWN	TNJ		08-08-05
FRACTIONAL: ±		CHECKED	BB		08-08-05
ANGULAR: MACH ± BEND ±		ENG APPR:			
TWO PLACE DECIMAL ±		MFG APPR:			
THREE PLACE DECIMAL ±		Q.A.			
MATERIAL		COMMENTS:			
NEXT ASSY	USED ON	FINISH	--		
APPLICATION	SCALE	1 : 35			
SIZE		DWG. NO.	REV.		
A		ATS-SCAT-886-AC-C1250			
WEIGHT:		SHEET 1 OF 1			

1500 GPD AeroCell® System

www.quanics.net/autocad.htm

ZONE		REV. DESCRIPTION		DATE	APPROVED

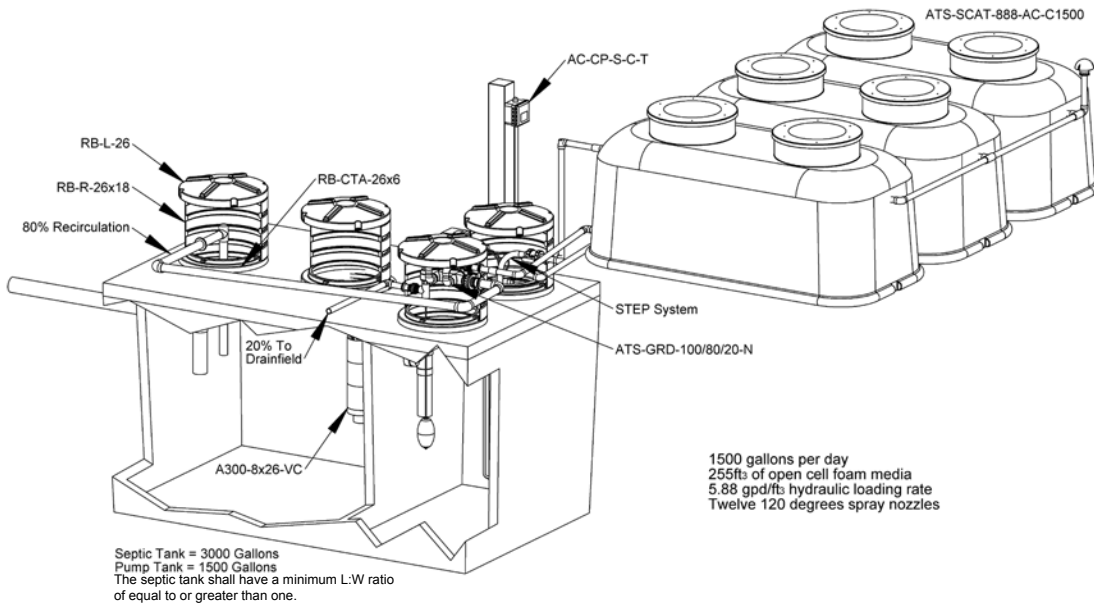

1500 gallons per day
 255ft³ of open cell foam media
 5.88 gpd/ft³ hydraulic loading rate
 Twelve 120 degrees spray nozzles

Septic Tank = 3000 Gallons
 Pump Tank = 1500 Gallons
 The septic tank shall have a minimum L:W ratio of equal to or greater than one.

- Parts Included:
- ATS-SCAT-888-AC-C1500
 - A300-8x26-VC
 - FPV-H44-4
 - P-SE-13T
 - PDS-ED-1.5
 - PDS-GT-1.25
 - PDS-GT-1.5 (2x)
 - AC-FT-3
 - AC-JSB-4
 - AC-CP-S-C-T
 - ATS-GRD-100/80/20-N
 - RB-CTA-26x6 (4x)
 - RB-R-26x18 (3x)
 - RB-L-26 (3x)

Product(s) covered by one or more U.S. and/or International patents. Other U.S. and International patents may be pending.

DIMENSIONS ARE IN INCHES		
TOLERANCES:		
FRACTIONAL ±	NAME	DATE
ANGULAR: MACH ± BEND ±	DRAWN	TNJ 08-08-05
TWO PLACE DECIMAL ±	CHECKED	BB 08-08-05
THREE PLACE DECIMAL ±	ENG APPR:	
	MFG APPR:	
	G.A.	
	COMMENTS:	
NEXT ASSY	USED ON	FINISH --
APPLICATION	SCALE	1 : 35

QUANICS Incorporated	
SIZE	DWG. NO.
A	ATS-SCAT-888-AC-C1500
WEIGHT:	SHEET 1 OF 1

500 GPD Bio-COIR® System

www.quanics.net/autocad.htm

ZONE		REV. DESCRIPTION		DATE	APPROVED

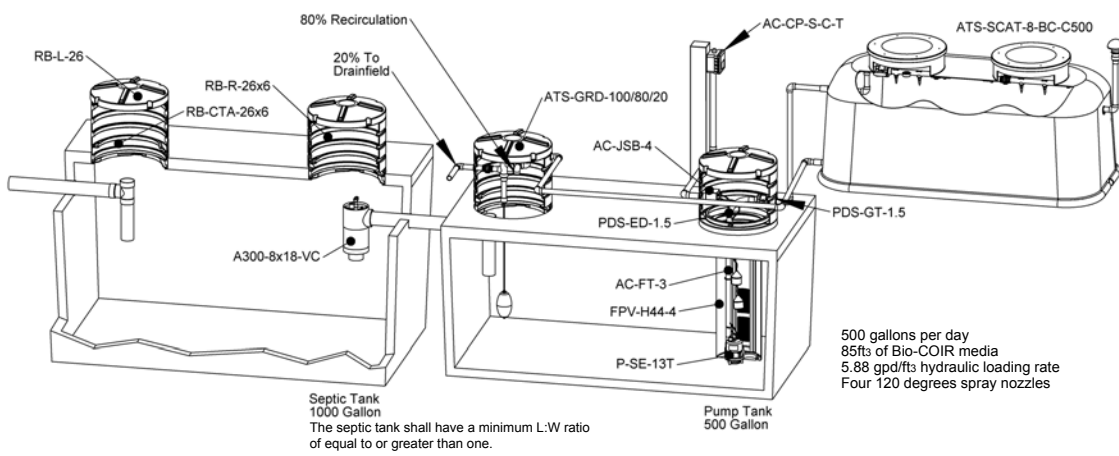

500 gallons per day
 85ft³ of Bio-COIR media
 5.88 gpd/ft³ hydraulic loading rate
 Four 120 degrees spray nozzles

Septic Tank
 1000 Gallon
 The septic tank shall have a minimum L:W ratio of equal to or greater than one.

Pump Tank
 500 Gallon

- Parts Included:
- ATS-SCAT-8-BC-C500
 - A300-8x18-VC
 - FPV-H44-4
 - P-SE-13T
 - PDS-ED-1.5
 - PDS-GT-1.5 (2x)
 - AC-FT-3
 - AC-JSB-4
 - AC-CP-S-C-T
 - ATS-GRD-100/80/20
 - RB-CTA-26x6 (4x)
 - RB-R-26x18 (3x)
 - RB-L-26 (3x)

Product(s) covered by one or more U.S. and/or International patents. Other U.S. and International patents may be pending.

DIMENSIONS ARE IN INCHES		
TOLERANCES:		
FRACTIONAL ±	NAME	DATE
ANGULAR: MACH ± BEND ±	DRAWN	TNJ 08-08-05
TWO PLACE DECIMAL ±	CHECKED	BB 08-08-05
THREE PLACE DECIMAL ±	ENG APPR:	
	MFG APPR:	
	G.A.	
	COMMENTS:	
NEXT ASSY	USED ON	FINISH --
APPLICATION	SCALE	1 : 40

QUANICS Incorporated	
SIZE	DWG. NO.
A	ATS-SCAT-8-BC-C500
WEIGHT:	SHEET 1 OF 1

750 GPD Bio-COIR® System

www.quanics.net/autocad.htm

ZONE		REVISIONS		DATE		APPROVED	
REV.		DESCRIPTION					

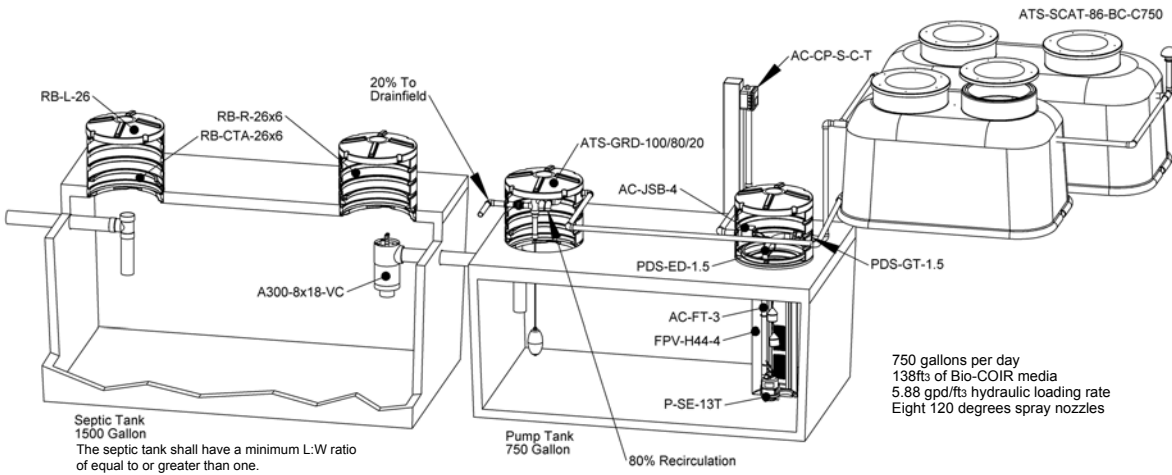

Parts Included:

- ATS-SCAT-86-BC-C750
- A300-8x18-VC
- FPV-H44-4
- P-SE-13T
- PDS-ED-1.5
- PDS-GT-1.5 (2x)
- AC-FT-3
- AC-JSB-4
- AC-CP-S-C-T
- ATS-GRD-100/80/20
- RB-CTA-26x6 (4x)
- RB-R-26x18 (3x)
- RB-L-26 (3x)

Product(s) covered by one or more U.S. and/or International patents. Other U.S. and International patents may be pending.

DIMENSIONS ARE IN INCHES		NAME	DATE
TOLERANCES:		DRAWN	TNJ 08-08-05
FRACTIONAL: ±		CHECKED	BB 08-08-05
ANGULAR: MACH ± BEND ±		ENG APPR.	
TWO PLACE DECIMAL ±		MFG APPR.	
THREE PLACE DECIMAL ±		G.A.	
MATERIAL		COMMENTS:	
NEXT ASSY	USED ON	FINISH	--
APPLICATION	SCALE	1 : 40	

QUANICS Incorporated

SIZE	DWG. NO.	REV.
A	ATS-SCAT-86-BC-C750	
WEIGHT:	SHEET 1 OF 1	

1000 GPD Bio-COIR System

www.quanics.net/autocad.htm

ZONE		REVISIONS		DATE		APPROVED	
REV.		DESCRIPTION					

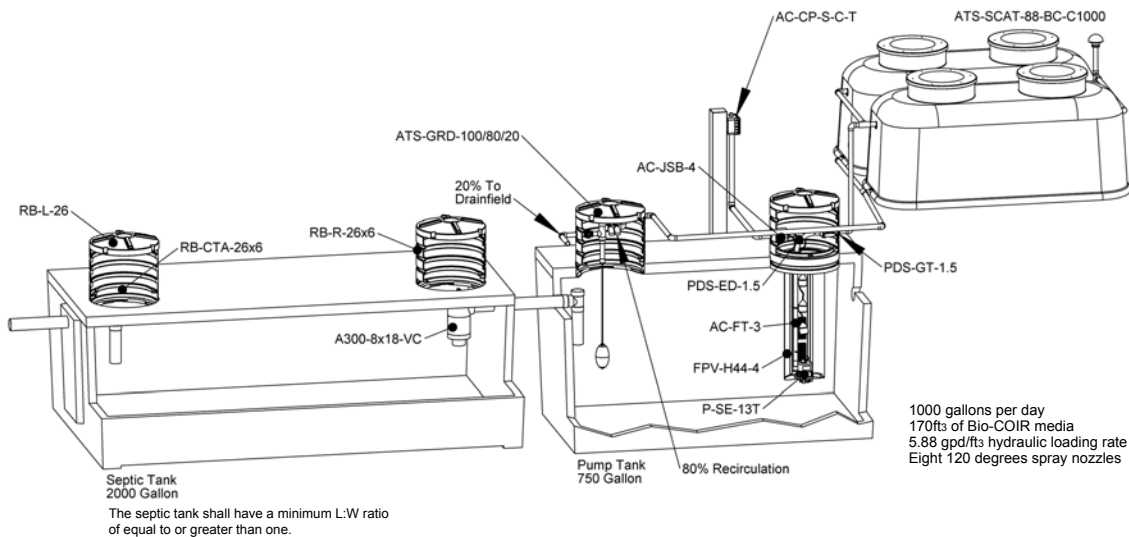

Parts Included:

- ATS-SCAT-88-BC-C1000
- A300-8x18-VC
- FPV-H44-4
- P-SE-13T
- PDS-ED-1.5
- PDS-GT-1.5 (2x)
- AC-FT-3
- AC-JSB-4
- AC-CP-S-C-T
- ATS-GRD-100/80/20
- RB-CTA-26x6 (4x)
- RB-R-26x18 (3x)
- RB-L-26 (3x)

Product(s) covered by one or more U.S. and/or International patents. Other U.S. and International patents may be pending.

DIMENSIONS ARE IN INCHES		NAME	DATE
TOLERANCES:		DRAWN	TNJ 08-08-05
FRACTIONAL: ±		CHECKED	BB 08-08-05
ANGULAR: MACH ± BEND ±		ENG APPR.	
TWO PLACE DECIMAL ±		MFG APPR.	
THREE PLACE DECIMAL ±		G.A.	
MATERIAL		COMMENTS:	
NEXT ASSY	USED ON	FINISH	--
APPLICATION	SCALE	1 : 45	

QUANICS Incorporated

SIZE	DWG. NO.	REV.
A	ATS-SCAT-88-BC-C1000	
WEIGHT:	SHEET 1 OF 1	

1250 GPD Bio-COIR® System

www.quanics.net/autocad.htm

ZONE		REV. DESCRIPTION		DATE	APPROVED

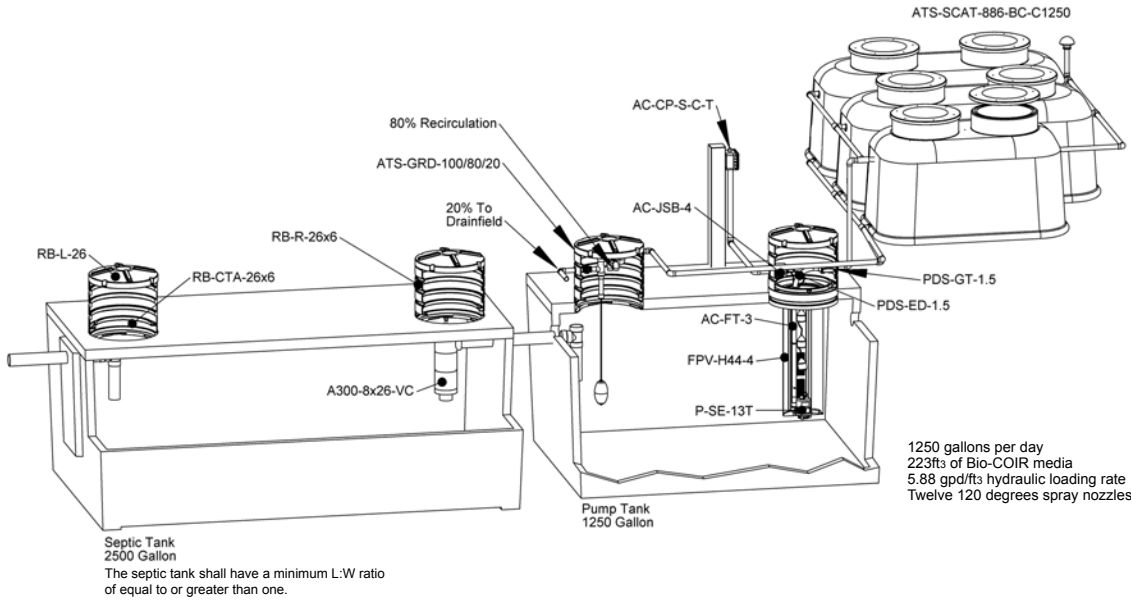

1250 gallons per day
223fts of Bio-COIR media
5.88 gpd/fts hydraulic loading rate
Twelve 120 degrees spray nozzles

Septic Tank
2500 Gallon
The septic tank shall have a minimum L:W ratio of equal to or greater than one.

Parts Included:

- ATS-SCAT-886-BC-C1250
- A300-8x26-VC
- FPV-H44-4
- P-SE-13T
- PDS-ED-1.5
- PDS-GT-1.5 (2x)
- AC-FT-3
- AC-JSB-4
- AC-CP-S-C-T
- ATS-GRD-100/80/20
- RB-CTA-26x6 (4x)
- RB-R-26x18 (3x)
- RB-L-26 (3x)

Product(s) covered by one or more U.S. and/or International patents. Other U.S. and International patents may be pending.

DIMENSIONS ARE IN INCHES		NAME	DATE	QUANICS Incorporated	
TOLERANCES:		DRAWN	TNJ		08-08-05
FRACTIONAL ±		CHECKED	BB		08-08-05
ANGULAR: MACH ± BEND ±		ENG APPR.			
TWO PLACE DECIMAL ±		MFG APPR.			
THREE PLACE DECIMAL ±		G.A.			
MATERIAL		COMMENTS:			
NEXT ASSY	USED ON	FINISH	--		
APPLICATION	SCALE	1 : 45			
SIZE	DWG. NO.	REV.			
A	ATS-SCAT-886-BC-C1250				
WEIGHT:	SHEET 1 OF 1				

1500 GPD Bio-COIR System

www.quanics.net/autocad.htm

ZONE		REV. DESCRIPTION		DATE	APPROVED

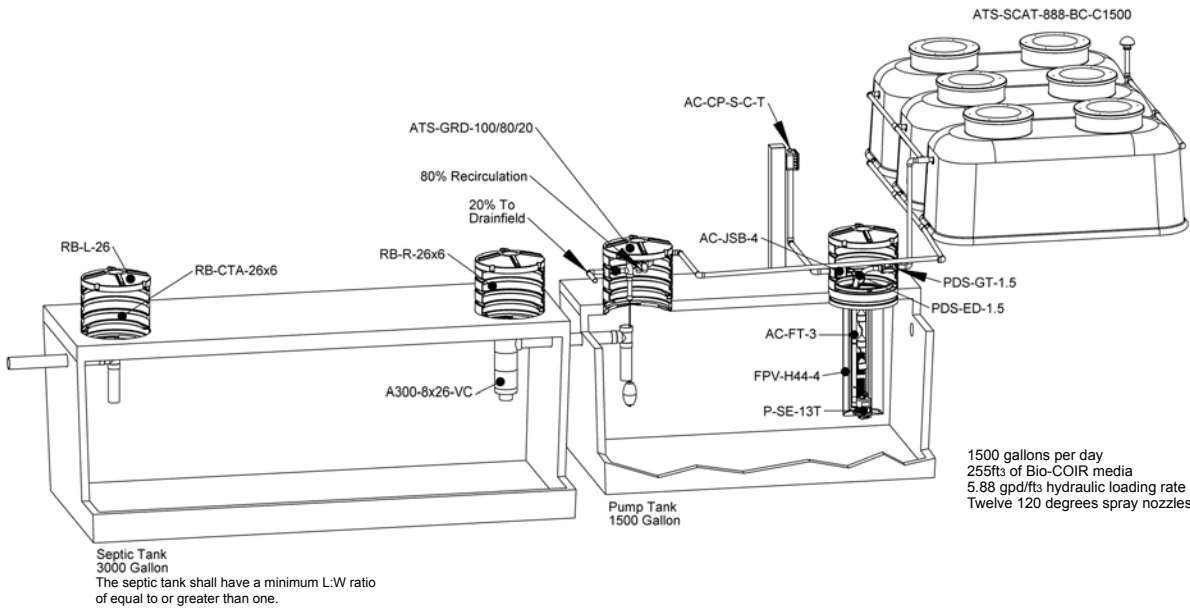

1500 gallons per day
255fts of Bio-COIR media
5.88 gpd/fts hydraulic loading rate
Twelve 120 degrees spray nozzles

Septic Tank
3000 Gallon
The septic tank shall have a minimum L:W ratio of equal to or greater than one.

Parts Included:

- ATS-SCAT-888-BC-C1500
- A300-8x26-VC
- FPV-H44-4
- P-SE-13T
- PDS-ED-1.5
- PDS-GT-1.5 (2x)
- AC-FT-3
- AC-JSB-4
- AC-CP-S-C-T
- ATS-GRD-100/80/20
- RB-CTA-26x6 (4x)
- RB-R-26x18 (3x)
- RB-L-26 (3x)

Product(s) covered by one or more U.S. and/or International patents. Other U.S. and International patents may be pending.

DIMENSIONS ARE IN INCHES		NAME	DATE	QUANICS Incorporated	
TOLERANCES:		DRAWN	TNJ		08-08-05
FRACTIONAL ±		CHECKED	BB		08-08-05
ANGULAR: MACH ± BEND ±		ENG APPR.			
TWO PLACE DECIMAL ±		MFG APPR.			
THREE PLACE DECIMAL ±		G.A.			
MATERIAL		COMMENTS:			
NEXT ASSY	USED ON	FINISH	--		
APPLICATION	SCALE	1 : 45			
SIZE	DWG. NO.	REV.			
A	ATS-SCAT-888-BC-C1500				
WEIGHT:	SHEET 1 OF 1				

ADVANCED TREATMENT SCAT® AeroCell® & Bio-COIR®

ATS-SCAT-6

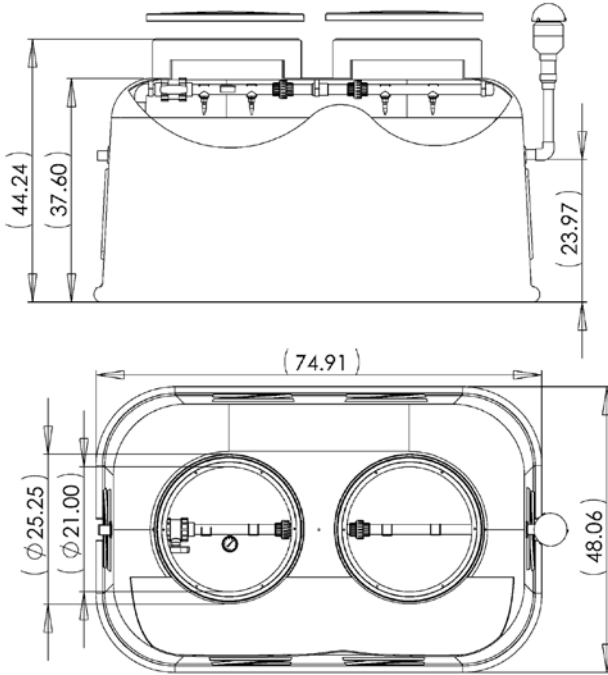

ATS-SCAT-8

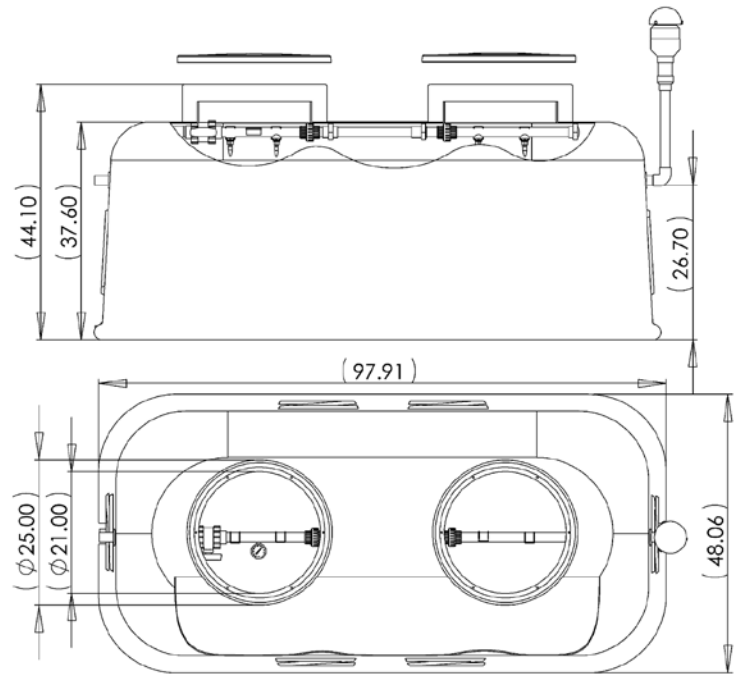

AeroCell & Bio-COIR Specifications

Model #	GPD Rating	Nozzles	Modules	Media (ft ³)	Loading (gpd/ft ³)	Septic Tank (gal)	Pump Tank (gal)	Individual Dose Volume (gal)	Discharge Volume per Individual Dose (gal)	Doses per 24 hrs.
ATS-SCAT-8-AC-C500 ATS-SCAT-8-BC-C500	500*	4	1	85	5.88	1000	500	25.6	5.12	98
ATS-SCAT-86-AC-C750 ATS-SCAT-86-BC-C750	750*	8	2	138	5.43	1500	750	51.2	10.2	73
ATS-SCAT-88-AC-C1000 ATS-SCAT-88-BC-C1000	1000*	8	2	170	5.88	2000	1000	51.2	10.2	98
ATS-SCAT-886-AC-C1250 ATS-SCAT-886-BC-C1250	1250*	12	3	223	5.61	2500	1250	76.8	15.3	81
ATS-SCAT-888-AC-C1500 ATS-SCAT-888-BC-C1500	1500*	12	3	255	5.88	3000	1500	76.8	15.3	98

*The Zabel® A300-8x18-VC model effluent filter is used in systems of 1200 gpd or less. The A300-8x26-VC filter is used in systems up to 1800 gpd. The septic tank shall have a minimum L:W ratio of equal to or greater than one.

Features

- Effluent discharge and carbon filter vent assemblies included
- Fiberglass lid with neoprene gasket and security screws included
- Indented flat spots on bottom for easy grommet and outlet pipe installation.
- .015 - .016 lbs/ft³/day organic loading rate

Warranty for Defects in Material and Workmanship

- Fiberglass SCAT Module - 2 years
- Effluent Discharge and Vent Assembly - 2 years

EFFLUENT FILTER

Filter Series (8")

A300-8x18-VC

A300-8x26-VC

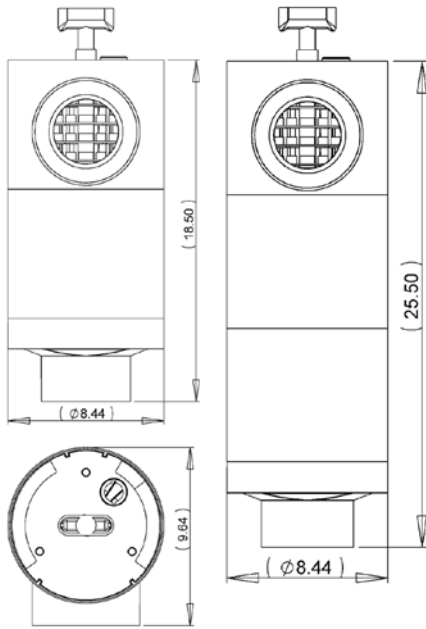

A300-8x18-VC

GPD: 1200 / FS: 1/32"

A300-8x26-VC

GPD: 1800 / FS: 1/32"

Features

- Patented effluent filter for light commercial, grease traps and in conjunction with advanced treatment systems
- Average of 50% to 90% reduction in TSS within 6 months of installation
- Average of 20% to 45% reduction in BOD₅ within 6 months of installation, reduction is dependent on the make-up of the wastewater
- Average of 60% to 90% reduction in FOG within 6 months of installation
- Filter cartridges are green for easy identification
- Outlet hub accepts 4" or 6" SCH 40 outlet pipe
- All Zabel® Filters accept SmartFilter® alarm switch

GPD = Maximum Gallons Per Day

FS = Filtration Size

Warranty for Defects in Material and Workmanship Effluent Filters - Limited Lifetime

FILTERED PUMP VAULT

Hanging

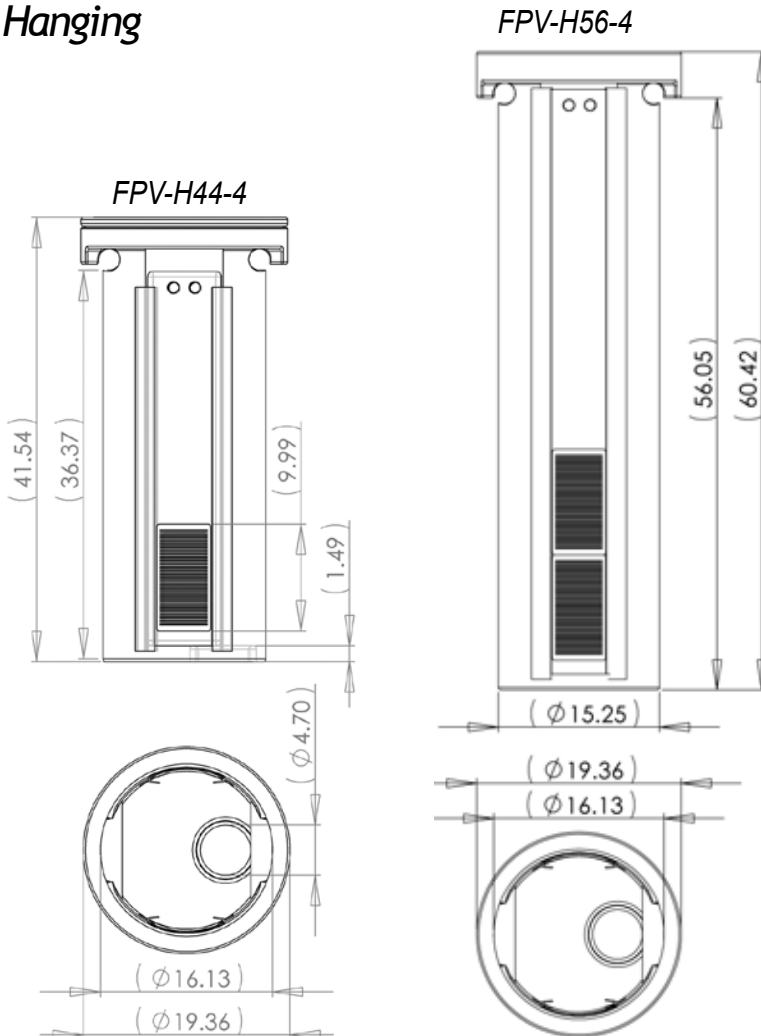

FPV-H44-4, FPV-H56-4

High density non-corrosive polyethylene plastic with stainless steel screws

Features

- Hanging filtered pump vault installs into primary or pump tanks
- Protects pump and disposal field from solids larger than 1/16"
- Available with either 2 or 4 filter plates
- Includes maintenance plate for servicing ease

Warranty for Defects in Material and Workmanship

FPVs - 2 Year

All FPVs when used with a QUANICS pump - 10 year

PRESSURE DISTRIBUTION Pumps

P-SE-13T

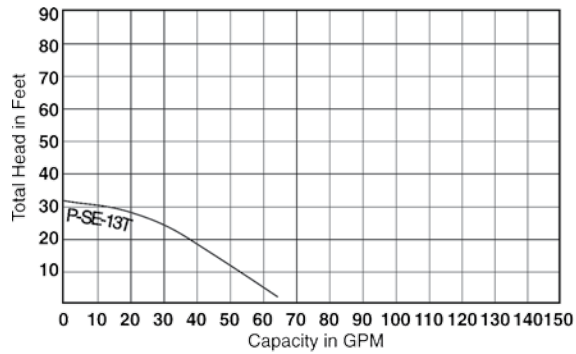
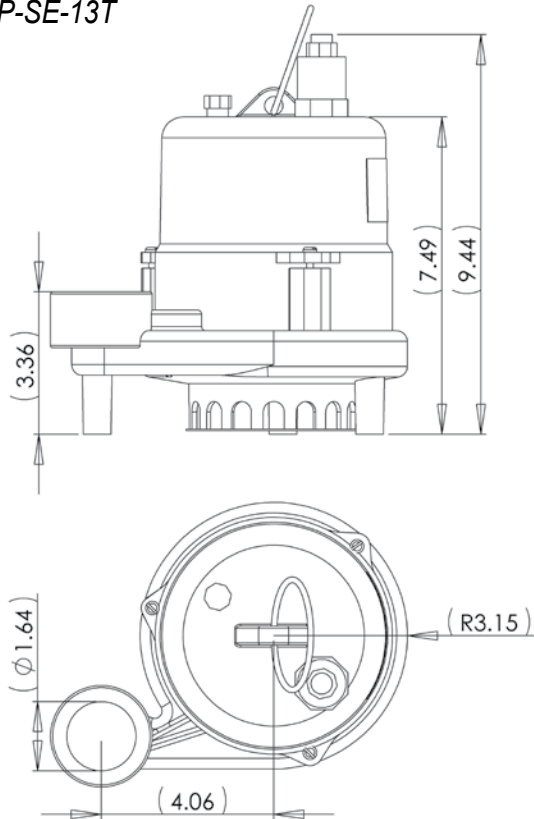

Specifications

Capacities: From 15 - 80 GPM

Heads: To 260 FT

Motor: 1/2 HP; hermetically sealed with automatic thermal overload

Electrical: 115V, 12.0 FLA, 1PH, 60Hz

Operation: Manual model (controls required)
Minimum Diameter: 4" (102mm)

Impeller: Delrin®, closed vane type

Solids handling: 1/8" (3.2mm)

Power Cord: 10' (3M), 300 V SJOW jacketed, 2-wire with ground

Materials of Construction: 300 grade stainless and cast-iron

Discharge: 1-1/2"

Warranty for Defects in Material and Workmanship

- All components - 3 Years

STEP SYSTEMS Effluent Discharges

PDS-ED-1.5

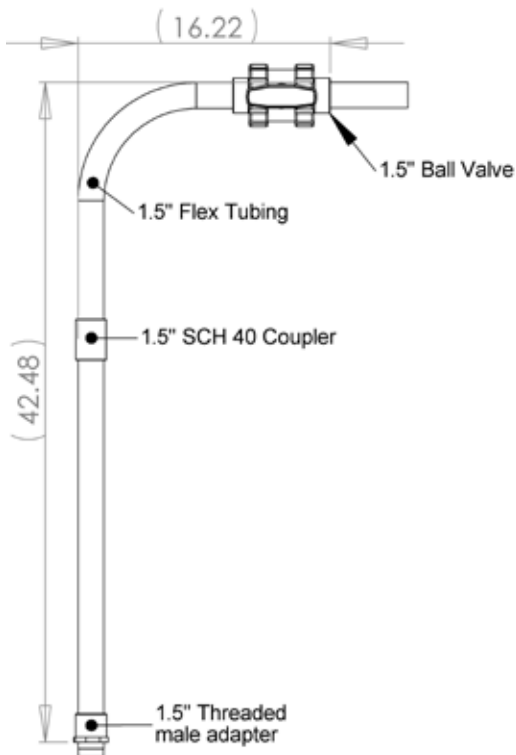

PDS-ED-2.0

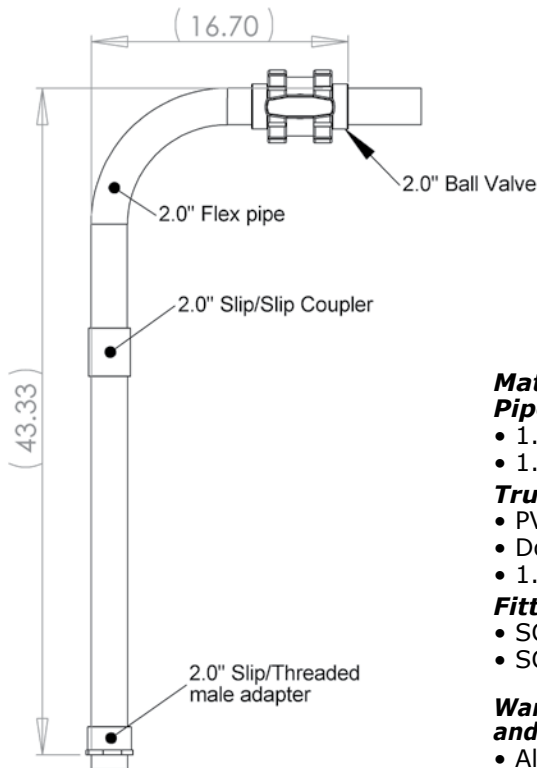

Materials

Pipe

- 1.5" or 2" SCH 40 PVC
- 1.5" or 2" PVC flex tubing

True Union Ball Valve

- PVC Plastic
- Double block, full port design
- 1.5" or 2" slip/slip hubs

Fittings

- SCH 40 PVC threaded slip adapter
- SCH 40 PVC slip/slip adapter

Warranty for Defects in Material and Workmanship

- All components - 2 Years

Pressure Distribution Grommets

PDS-GT-1.5

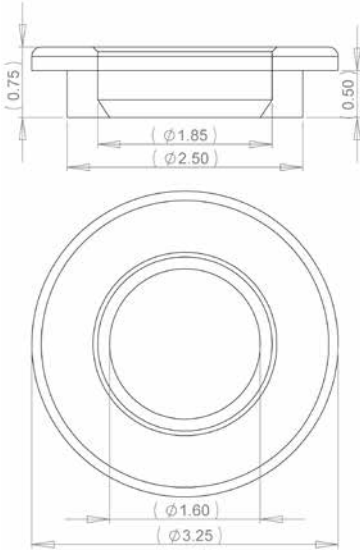

PDS-GT-2.0

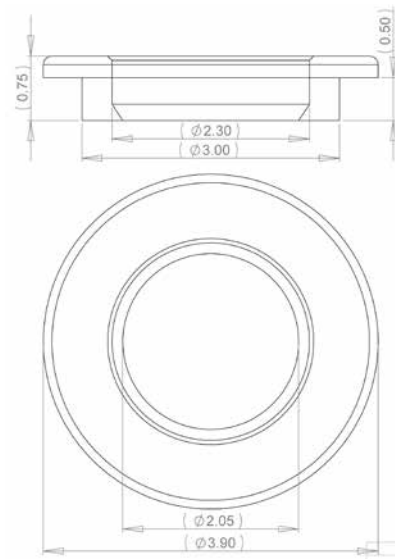

Materials

- 65 Durometer PVC

Warranty for Defects in Material and Workmanship

- All components - 2 Years

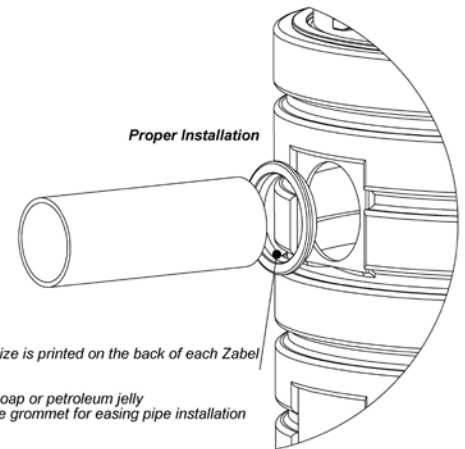

Installation Tips:

Proper hole saw size is printed on the back of each Zabel Grommet.

Put dishwashing soap or petroleum jelly on the inside of the grommet for easing pipe installation

STEP SYSTEMS Float Tree

AC-FT-3

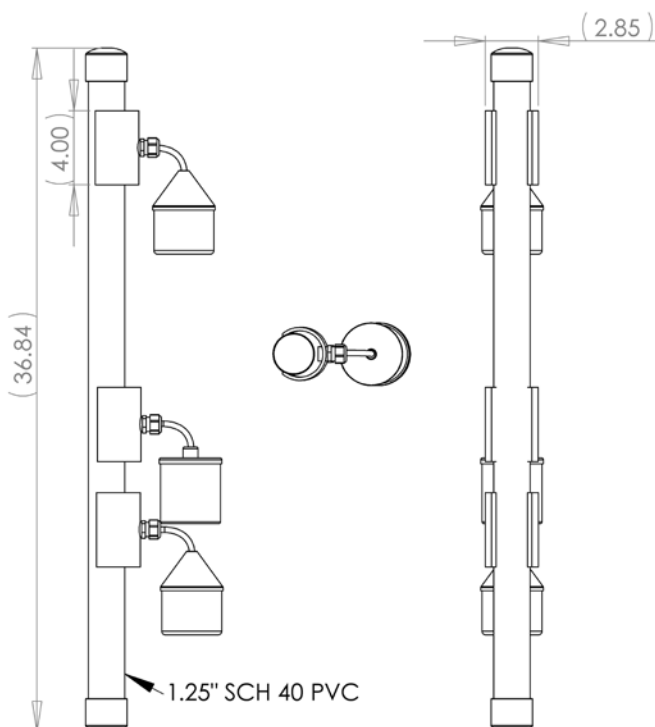

Materials

Pipe

- 1.5" or 2" SCH 40 PVC
- 1.5" or 2" PVC flex tubing

True Union Ball Valve

- PVC Plastic
- Double block, full port design
- 1.5" or 2" slip/slip hubs

Fittings

- SCH 40 PVC threaded slip adapter
- SCH 40 PVC slip/slip adapter

Warranty for Defects in Material and Workmanship

- All components - 2 Years

STEP SYSTEMS Junction Box

AC-JSB-4

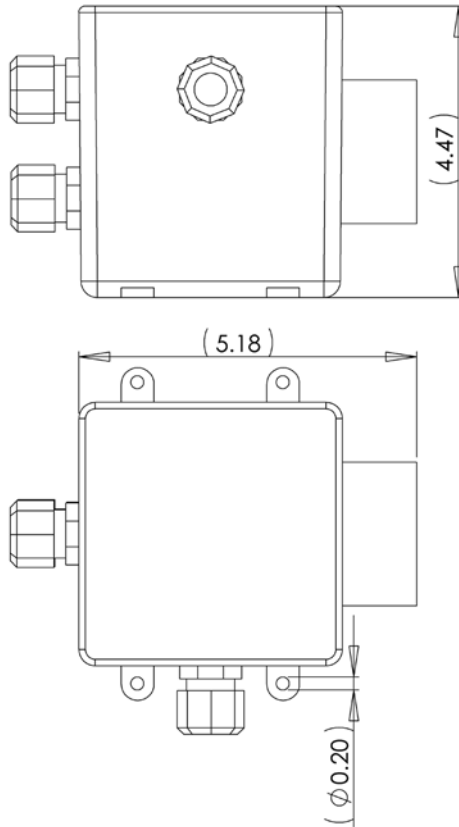

Materials

Lid & Box

- High impact, corrosion resistant thermoplastic
- Weatherproof
- 1/2" UL approved, CSA Certified round cable liquid-tight strain relief connectors
- 1-1/2" terminal adapter hub

Gasket

- Flexible PVC

Screws

- Brass

Warranty for Defects in Material and Workmanship

- Junction Boxes - 3 Years

STEP SYSTEMS Control Panel

AC-CP-S-C-T

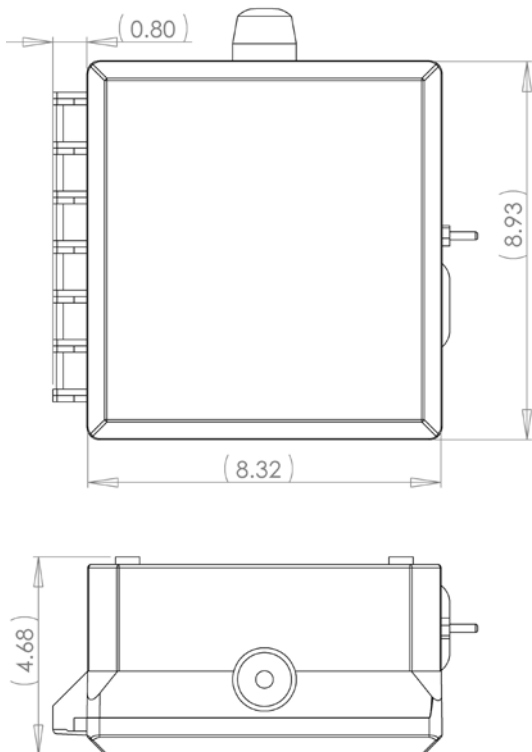

Specifications

Enclosure

- Measures 10x8x4 inches (25.40x20.32x10.16 cm). NEMA 4X (ultraviolet stabilized thermoplastic with removable flanges for outdoor or indoor use).
- Magnetic Motor Contactor controls pump by switching hot electrical lines
- HOA Switch for manual pump control (mounted on circuit board)
- Float Switch Terminal Block
- Alarm and Control Fuses
- Programmable Timer with separate variable controls allows for setting the on and off times from .05 seconds to 30 hours.
- Circuit Breaker provides pump disconnect and branch circuit protection

Power Supply

- Pump-120/208/240V, 7-15FLA
- Alarm-120V

Standard Alarm Package

- Red Alarm Beacon provides 360 visual check of alarm condition
- Exterior Horn Test/Normal/Silence Switch allows alarm horn to be silenced and testing of horn and light to ensure proper operation of alarm system
- Horn Silence Relay automatically resets alarm after alarm condition has been resolved (mounted on circuit board)

Warranty for Defects in Material and Workmanship

- Control Panel - 3 Years

ADVANCED TREATMENT Recirculation Devices

ATS-GRD-100/80/20

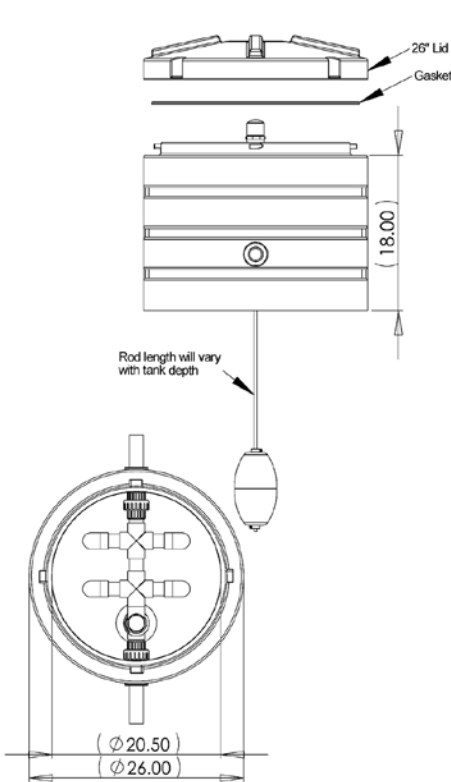

ATS-GRD-100/80/20-N

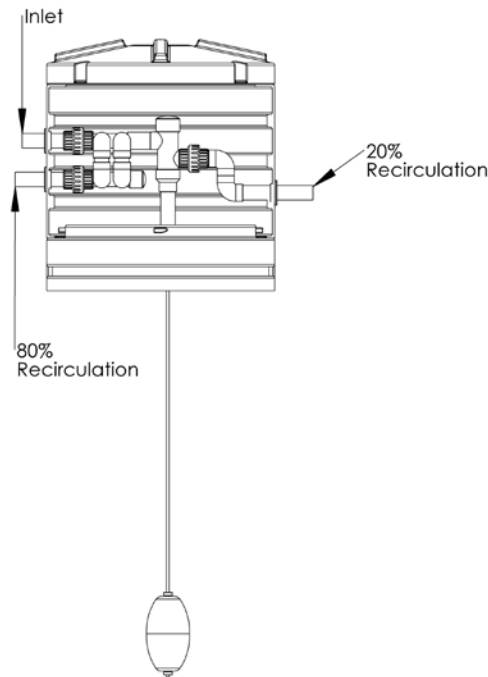

Materials

Riser and Lid

- High density non-corrosive polyethylene plastic
- Tested to withstand up to a 2500 lb wheel load
- Neoprene gasket
- Stainless steel tamper resistant hardware
- 26" diameter lid

Effluent Discharge Assembly

- 1.25" Sch 40 PVC Pipe
- Rubber Grommets

Float Valve Assembly

- 60" Stainless steel rod
- Polypropylene float

Warranty for Defects in Material and Workmanship

- Riser and Lid - 2 Years
- Effluent Discharge Assembly - 2 Years
- Float Valve Assembly - 2 Years

STEP SYSTEMS Risings, Lids, Tank Adapters

RB-RTA-26x2 (Retrofit Tank Adapter)

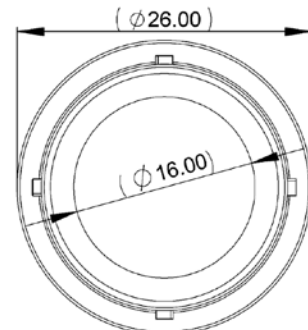
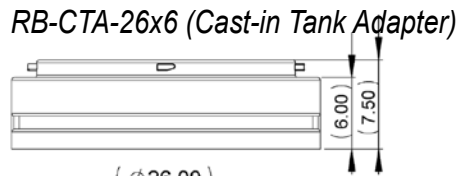
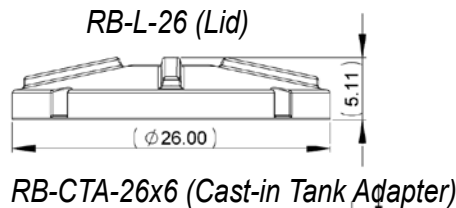
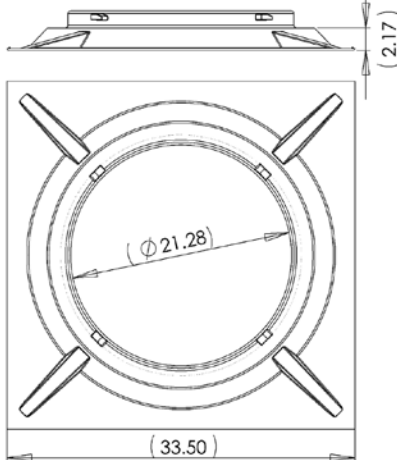

Materials:

Risings and Lids

- High density non-corrosive polyethylene plastic
- Stainless steel screws
- Neoprene gasket

IMPORTANT:

- When adding risers together for deeper installations **QUANICS** does not recommend exceeding a maximum depth of 48".
- Neoprene gaskets must be installed as per instructions
- To prevent unauthorized entry install all tamper resistant fasteners as per instructions

Warranty for Defects in Material and Workmanship

- Riser, Lids & Tank Adapters - 2 Years

Wiring Schematics

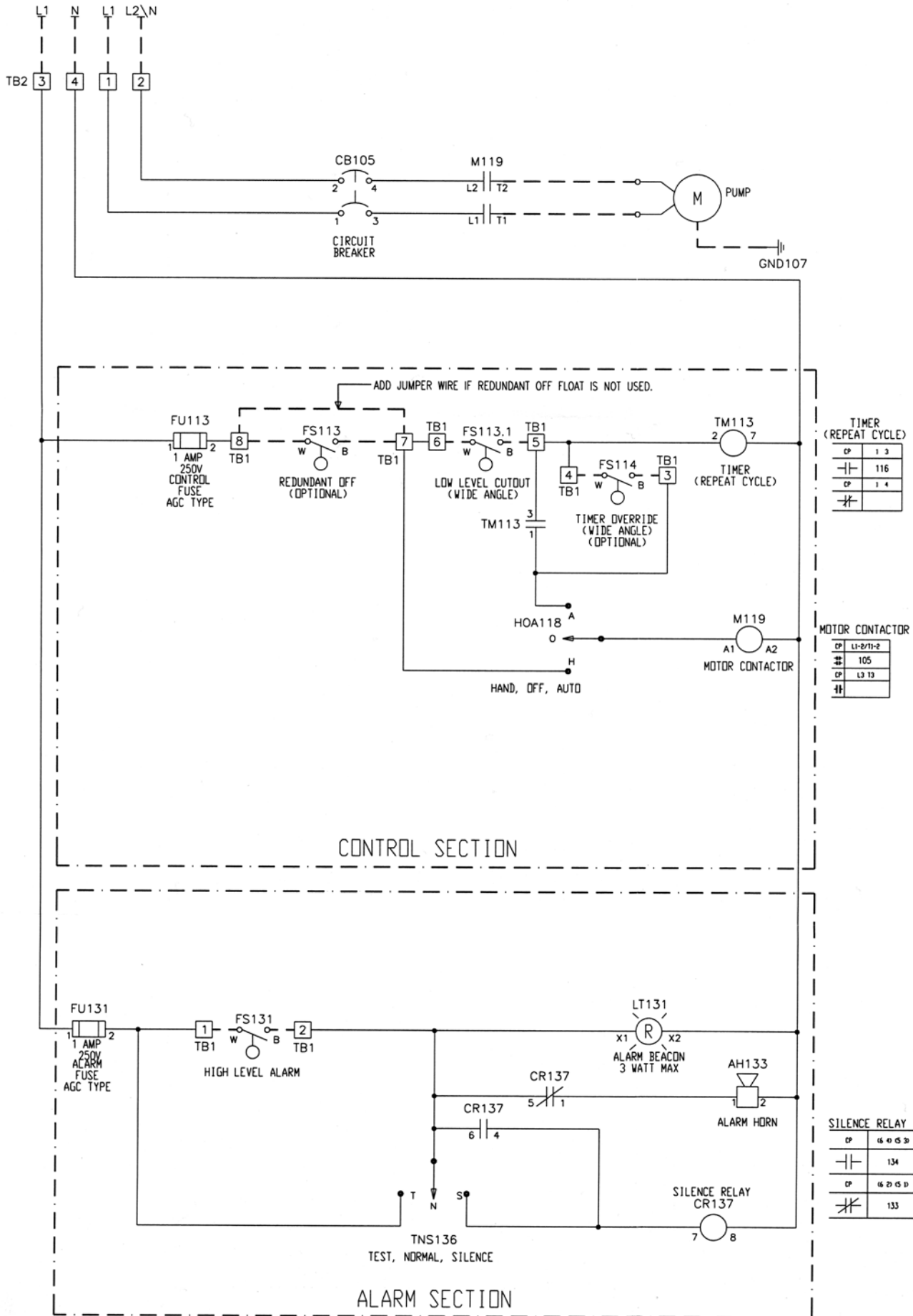

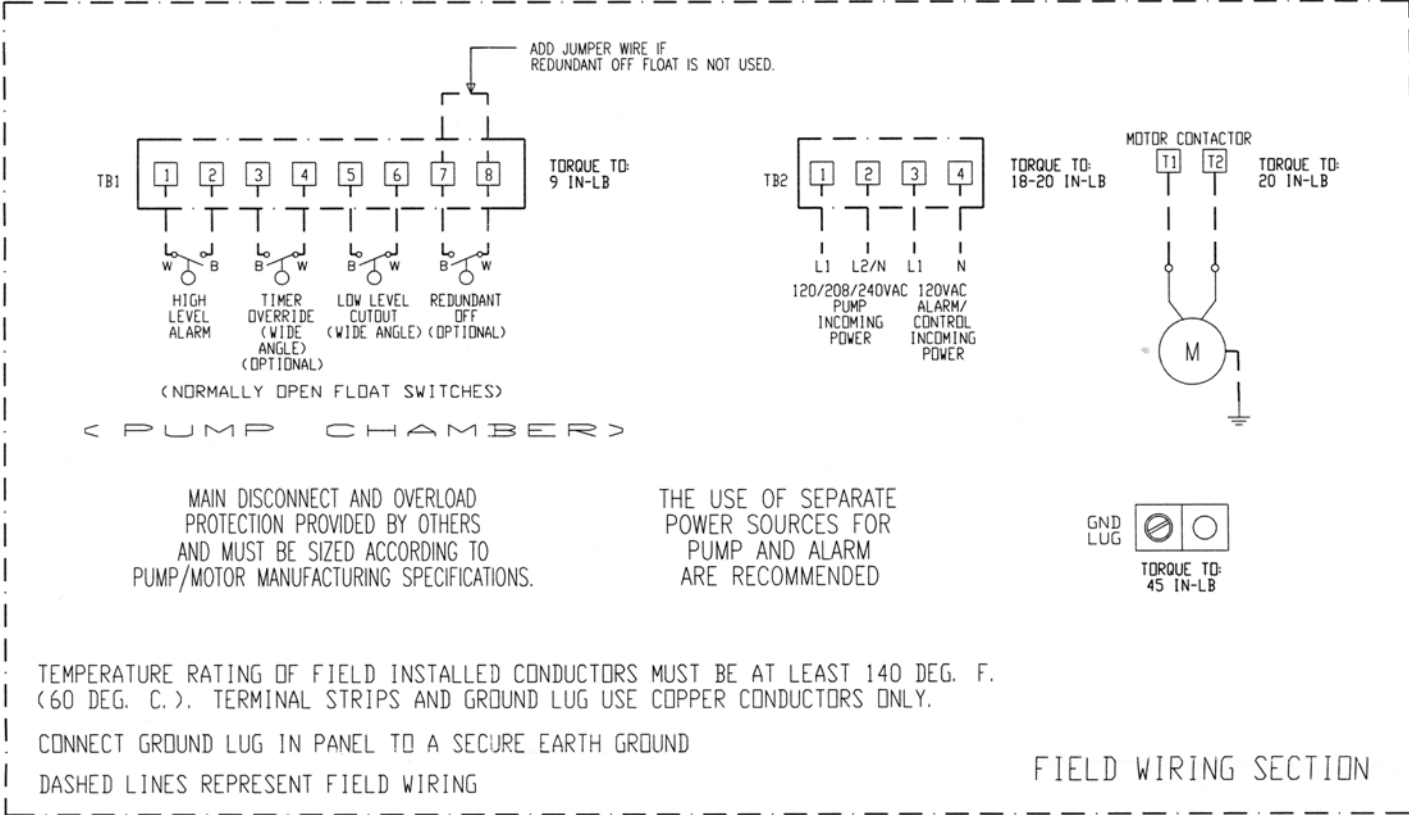

Consecutively Serial Numbered Data Plates & Maintenance Sticker

HOMEOWNER

1. Silence unit

2. Contact maintenance personnel for service
(Maintenance should be performed by trained personnel only)

YOUR SERVICE COMPANY:

USE BALLPOINT PEN

4"

2"

Quanics
Engineering Water Solutions™

Model # **ATS-SCAT-8-AC-C500**

Patent(s) **U.S. & Canadian Patents**

Capacity **500 Gallons Per Day**

Serial # _____

Panel # **AC-CP-S-C-T**

P.O. Box 1520
Crestwood, KY 40014
1-877-QUANICS

AeroCell
Treatment System

NSF Certified to NSF/ANSI Standard 40 Class 1

122905-000

4"

2"

Quanics
Engineering Water Solutions™

Model # **ATS-SCAT-8-BC-C500**

Patent(s) **U.S. & Canadian Patents**

Capacity **500 Gallons Per Day**

Serial # _____

Panel # **AC-CP-S-C-T**

P.O. Box 1520
Crestwood, KY 40014
1-877-QUANICS

Bio-COIR
Naturally Treated Wastewater

NSF Certified to NSF/ANSI Standard 40 Class 1

122905-000

Property Owners Limited Warranty
And Service Agreement
AeroCell® or Bio-COIR® Advanced Treatment System

THIS AGREEMENT is made by and between:

(Name) _____ (Street address) _____ (City/state/zip code) _____
Hereinafter PROPERTY OWNER; and

(Name) _____ (Street address) _____ (City/state/zip code) _____
Hereinafter SERVICE PROVIDER/INSTALLER; for the purpose of providing maintenance service for an AeroCell or Bio-COIR Advanced Treatment System, Hereinafter AeroCell/Bio-COIR; Installed at

(Location Name) _____ (Street address) _____ (City/state/zip code) _____

Service Period: The service period begins on the date of Final Inspection and approval by the governing regulatory authority or date of PROPERTY OWNER use, whichever comes first. This agreement is for a service period of two (2) years.

Service Charge: This initial two (2) year service agreement is included in the initial system purchase price. The manufacturer or authorized representative shall make available for purchase by the owner an extended service policy with terms comparable to those in the initial service policy. The cost of the extended service agreement is (\$ _____).

Additional Charges:

This contract price does not include the cost of the following items, a) pumping the septic tank or pump basin(s), b) repair or replacement of parts that are furnished or manufactured by parties other than **QUANICS™**, or c) repair or replacement of parts manufactured by **QUANICS** for which the warranty has expired.

AeroCell/Bio-COIR Systems: The AeroCell/Bio-COIR Systems includes the septic tank(s), septic tank filter or filter plates, pump basin(s), pump(s) and controls, recirculation device, final dispersal system, AeroCell/Bio-COIR Modules/ and all miscellaneous parts attached to and required for the operation and service of the system.

PROPERTY OWNER Responsibilities

The PROPERTY OWNER confirms that he has read and understands the AeroCell/Bio-COIR Operation Manual and agrees to operate the **QUANICS** AeroCell/Bio-COIR Advanced Treatment System in accordance with **QUANICS**'s operating instructions. Failure to use the system in accordance with the Operation Manual will void all warranties. All repairs required to restore the system to normal operation will be at the PROPERTY OWNER's expense.

Service Provided:

Under this agreement, normal service means minor adjustments and repairs required to keep the system in proper operation and does not include repairs required by improper installation or misuse of the system by others. Service also does not include repair or replacement of any components that may be required due to normal use and wear that are not covered by **QUANICS**'s warranty. **QUANICS** or **QUANICS**'s Certified SERVICE PROVIDER shall inspect the AeroCell/Bio-COIR systems once each six (6) months for a period of two (2) years, and service the components as outlined below:

General Service:

1. Waste Flow Usage: Determine the daily waste flow by reading the water meter or, if so equipped, the system flow meter.
2. Collect Effluent Sample: Sample should be clear with a slight yellow tint, free from suspended solids and free from septic odor. Samples not meeting this criteria should be analyzed for BOD and TSS levels.
3. PROPERTY OWNER Notification: Send a copy of the service report to the PROPERTY OWNER. Advise the PROPERTY OWNER in writing of any problems or corrections including excessive water use. Notify the owner in writing about improper system operations that cannot be remedied at the time of inspection.
4. Regulatory Notification: Send a copy of the service report to the applicable regulatory agency, if required.
5. Manufacturer Notification: Send a copy of the service report to **QUANICS** as required to continue the AeroCell Limited Warranty.

QUANICS Components:

1. AeroCell/Bio-COIR: Remove and clean the spray nozzles. Inspect the pipe orifice and clean as needed. Inspect the foam media and clean as needed.
2. Pump(s) and Controls: Inspect the pumps(s) and controls for proper operation and settings. Activate the components and observe for proper function. Adjust settings as needed.
3. Septic Tank Filter/Filtered Pump Vault: Inspect the filter or filter plates and clean as needed.
4. Pump Basin(s): Inspect for excessive solids buildup and notify the PROPERTY OWNER to have the Basin pumped or upon PROPERTY OWNER’s request pump the tank at the PROPERTY OWNER’s expense.
5. Miscellaneous QUANICS™ Components: Check any other QUANICS components and adjust as necessary.

NON-QUANICS Components:

1. Septic Tank & Pump Tank: Inspect for excessive solids buildup and notify the PROPERTY OWNER to have the tank(s) pumped or upon PROPERTY OWNER’s request pump the tank at the PROPERTY OWNER’s expense.
2. Final Dispersal System: Inspect the system for signs of improper effluent discharge. Inspect the system for proper surface diversions. Advise the system PROPERTY OWNER of any corrections they should make.
3. Miscellaneous Components: Check any other components and adjust as necessary. Advise the PROPERTY OWNER if repairs are required.

Emergency Service: In the event the AeroCell/Bio-COIR unit(s) stops operating, service shall be provided within 48 hours of notification to the authorized SERVICE PROVIDER/INSTALLER. Emergency Service required because of PROPERTY OWNER abuse or misuse, or because of repairs or service to the AeroCell/Bio-COIR unit(s) by an unauthorized third party shall be at the PROPERTY OWNER’S expense.

QUANICS Limited Warranty:

QUANICS warrants the system to be free from defects from material and workmanship as follows: AeroCell/Bio-COIR treatment unit(s), controls, filters, risers & basins for a period of two years from the date of installation; pumps for a period of three years from the date of installation; and AeroCell/Bio-COIR foam for a period of ten years from the date of installation. Failed warranted parts shall be prorated over the period of use with cost calculated at the list price at the time of failure. Discontinued parts will be replaced with the closest current QUANICS equivalent. In no event shall QUANICS be liable for any incidental or consequential damages or any labor, material, freight or any other expense required to replace, correct or reinstall the product. QUANICS’s liability is limited to repair or replacement of the part. Except as stated herein, there are no warranties express or implied, including the warranty of merchantability or warranty of fitness for a specific purpose. All warranties are void if the product has been improperly modified, applied or installed, subjected to misuse or abuse. All warranties are void if this Service Contract is terminated for lack of payment or is not renewed at the end of the contract period.

SERVICE PROVIDER/INSTALLER Limited Warranty

The SERVICE PROVIDER/INSTALLER extends to the PROPERTY OWNER all limited warranties as provided by any manufacturers. Any parts not specifically warranted by any manufacturer shall be warranted by the SERVICE PROVIDER/INSTALLER for material and workmanship including labor to repair or replace any defective parts for a period of two years beginning on the date of final inspection and approval by the governing regulatory authority or date of PROPERTY OWNER use whichever comes first.

This agreement contains all warranties, representations and conditions made by and between the parties hereto. No modification, amendment, discharge or supplement to this agreement or waiver or release of any term hereof shall be valid or binding unless in writing and signed by all of the parties hereto. This agreement shall be governed, construed and interpreted in accordance with the laws of the Commonwealth of Kentucky.

Accepted by:

Accepted by:

PROPERTY OWNER

INSTALLER/SERVICE PROVIDER

Date

Date



P.O. BOX 1520
6244 OLD LAGRANGE ROAD
CRESTWOOD, KY 40014
www.quanics.net

PHONE: (502) 992-8200
1-877-QUANICS
FAX: (502) 992-8249

Treatment system service provider: