



## Risers & Lids

(22" Diameter)

### Features:

- Patented 22" polyethylene risers
- All components include twist lock tabs
- Tamper resistant fasteners included with each lid
- Tested to withstand up to 2500 lb wheel load
- May be cast-in or retrofit to any concrete tank

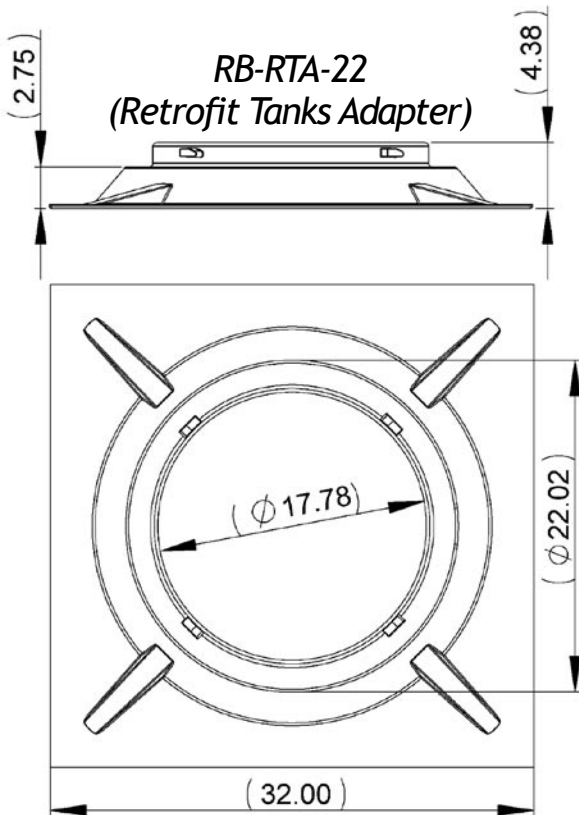
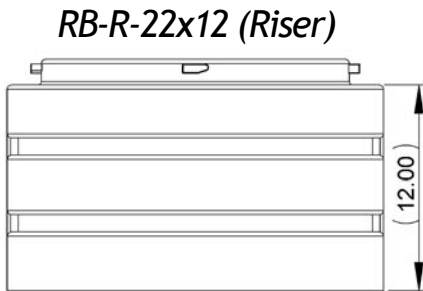
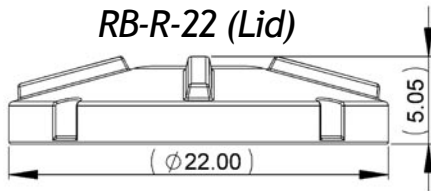

RB-R-22x38 (Riser)

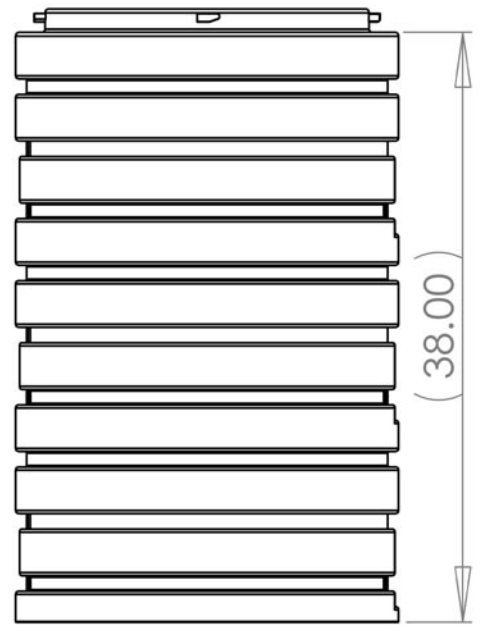

RB-R-22x6 (Riser)

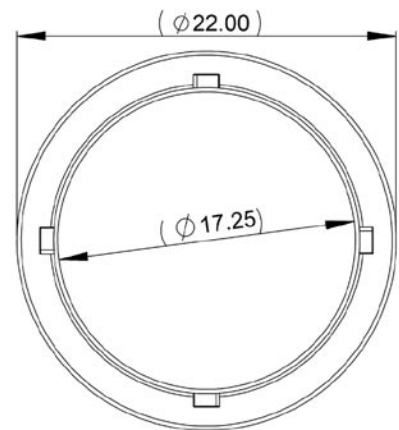
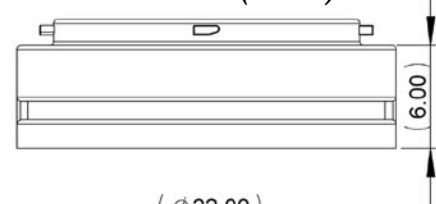

### Product features:

#### Risers and Lids

- High density non-corrosive polyethylene plastic
- Stainless steel screws
- Neoprene gasket

#### Warranty for Defects in Material and Workmanship

- Risers and Lids - 2 Years

#### IMPORTANT:

- When adding risers together for deeper installations Quanics does not recommend exceeding a maximum depth of 50".
- Neoprene gaskets must be installed as per instructions
- To prevent unauthorized entry install all tamper resistant fasteners as per instructions

AutoCad dwg files at [www.quanics.net](http://www.quanics.net)

**1-877-QUANICS - [www.quanics.net](http://www.quanics.net)**



© 2007, Quanics Inc. All rights reserved.  
Product(s) covered by one or more U.S.  
and/or International patents. Other U.S. and  
International patents may be pending.

