

EZ Series®

SJE-Rhombus® Type EZS

Installation Instructions and Operation/Troubleshooting Manual

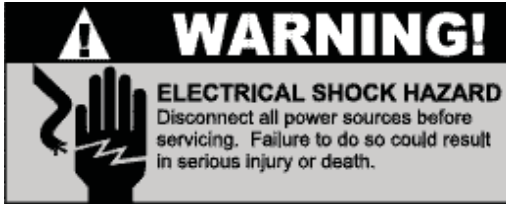

Warranty void if panel is modified.

Call factory with servicing questions:
1-800-RHOMBUS
(1-800-746-6287)

Manufactured by:

SJE
Rhombus®

22650 County Highway 6 ■ P.O. Box 1708
Detroit Lakes, Minnesota 56502 USA
1-888-DIAL-SJE (1-888-342-5753)
Phone: 218-847-1317 ■ Fax: 218-847-4617
E-mail: customer.service@sjerrhombus.com
Website: www.sjerrhombus.com

©SJE-Rhombus
Printed in USA
1023074D • Rev 11/15

This control panel must be installed and serviced by a licensed electrician in accordance with the National Electric Code NFPA-70, state and local electrical codes.

All conduit running from the sump or tank to the control panel must be sealed with conduit sealant to prevent moisture or gases from entering the panel. **NEMA 4X enclosures are for indoor or outdoor use**, primarily to provide a degree of protection against corrosion, windblown dust and rain, splashing water and hose-directed water. **Cable connectors must be liquid-tight in NEMA 4X enclosures.**

Installation

The EZ Series® Type EZS control panels are designed to control single phase pump(s). The controller records pump status, number of cycles, elapsed run time, alarm counter, and float error counts.

Mounting the Control Panel

Note: The control panel should not be mounted in a location that may be subject to submersion.

1. Determine mounting location for panel. If distance exceeds the length of either the float cables or the pump power cables, splicing will be required. For outdoor or wet installation, we recommend the use of an SJE-Rhombus® liquid-tight junction box with liquid-tight connectors to make required connections. **You must use conduit sealant to prevent moisture or gases from entering the panel.**
2. Mount control panel with mounting devices furnished.
3. Determine conduit entrance locations on control panel. Check local codes and schematic for the number of power circuits required. **(Float cables require separate conduit from power and pump cables.)**

Note: Be sure the proper power supply voltage, amperage, and phase meet the requirements of the pump motor(s) being installed. If in doubt, see the pump identification plate for voltage/phase requirements.

4. Drill proper size holes for type of connectors being used.

Note: If using conduit, be sure that it is of adequate size to pull the pump cable(s) through.

5. Attach cable connectors and/or conduit connectors to control panel.

**FOR INSTALLATION REQUIRING
A SPLICE, FOLLOW STEPS 6-10;
FOR INSTALLATION WITHOUT A
SPLICE, GO TO STEP 11.**

6. Determine location for mounting junction box according to local code requirements. **Do not** mount the junction box inside the sump or basin.
7. Mount junction box to proper support.
8. Run conduit to junction box. Drill proper size holes for the type of conduit used.

Installation Instructions

9. Identify and label each wire before pulling through conduit into control panel and junction box. Make wire splice connections at junction box.
10. Firmly tighten all fittings on junction box.
11. If a junction box is not required, pull cables through conduit into control panel.
12. Connect pump wires per wiring diagram or schematic and float wires to the proper terminals as shown on the schematic.
13. Connect pump, control, and alarm incoming power conductors to proper position on terminals. See schematic for terminal connections.

VERIFY CORRECT OPERATION OF CONTROL PANEL AFTER INSTALLATION IS COMPLETE.

Installation of Floats

CAUTION: The use of one wide angle float or pressure switch across stop and start float connections is not allowed. If control switch cables are not wired and mounted in the correct order, the pump system will not function properly. Control switches need to run in separate conduit from pump and power lines.

WARNING: Turn off all power before installing pump wires in pump chamber. Failure to do so could result in serious or fatal electrical shock.

1. Determine your normal operating level and desired float configuration, as illustrated in **Figures 2-5**.
2. Mount float switches at appropriate levels. Be sure that floats have free range of motion without touching each other or other equipment in the basin.
3. For mounting clamp installation: place the cord into the clamp as shown in **Figure 1**. Locate the clamp at the desired activation level and secure the clamp to the discharge pipe as shown in **Figure 1**.

NOTE: Do not install cord under hose clamp.

4. Tighten the hose clamp using a screwdriver. Over tightening may result in damage to the plastic clamp. Make sure the float cable is not allowed to touch the excess hose clamp band during operation.

NOTE: All hose clamp components are made of 18-8 stainless steel material. See your SJE-Rhombus® supplier for replacements.

5. If using an optional redundant off float, mount slightly below the timer enable float.
6. The alarm float can be positioned anywhere that the alarm level is desired.

Figure 1

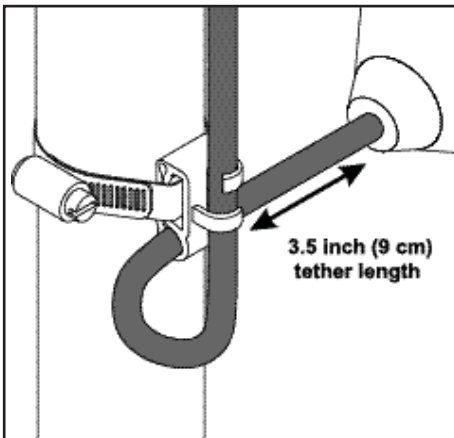

Figure 2
Simplex Timed Dose

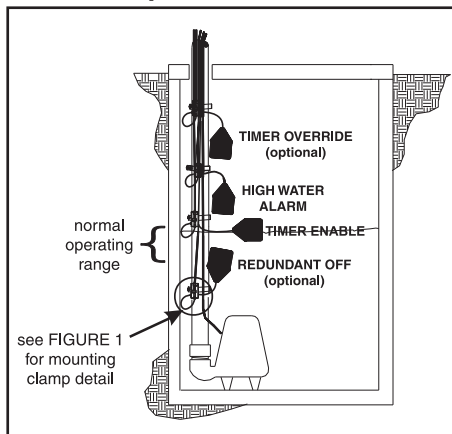

Figure 3
Simplex Demand

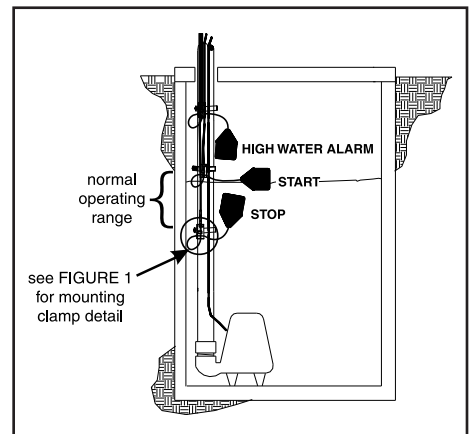

Figure 4
Duplex Demand 3 Float

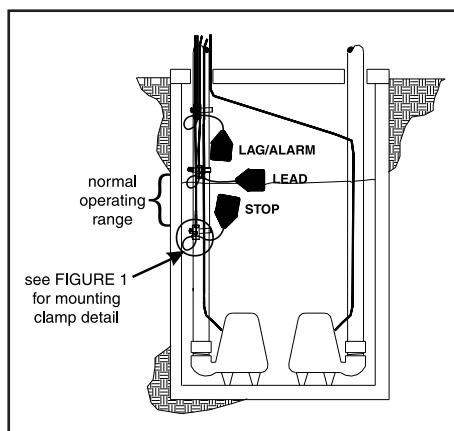
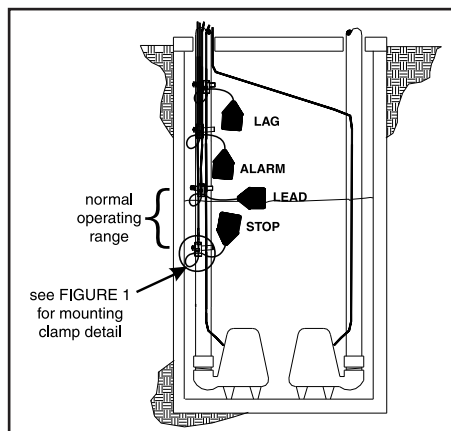

Figure 5
Duplex Demand 4 Float



Operations

The EZ Series® (EZS) control panel uses float switches to continuously monitor and control the liquid level in the tank.

Hand Operation - Press and hold the “Push to Run” switch if stop float is OPEN. If stop float is CLOSED, press “Push to Run” switch and the pump will run until stop float opens.

Off Operation - Turn control/alarm breaker off to be in Off operation.

Auto Operation - In time dose (t-dose) mode the timer controls pump ON and OFF time as long as the timer enable float is raised. In demand (d-dose) mode, the stop and start floats control the pump.

Alarm Count - Shown on display as $\boxed{AL.CE}$, counts the number of times the alarm is activated. Note: Alarm counter does not include testing operations in the total count. High alarm and alarm power loss add to count.

Green Control and Alarm Power Indicators - Illuminates when control power and alarm power is present. Alarm light will flash if alarm power is lost.

Timer Override Float - Overrides the OFF time and pump will run for full dose ON time. (timed dose only, optional)

Float Error Count - Shown on the display as $\boxed{FE.CE}$. Counts the number of times floats are out of sequence. Alarm horn will sound and alarm light will flash.

Timer Override Count - Shown on the display as $\boxed{EO.CE}$. Counts the number of times the timer override float is activated. (timed dose only)

Time left in “On” time cycle - Shown on the display as $\boxed{E-On}$. Counts down the time left in the “On” cycle. (timed dose only)

Time left in “Off” time cycle - Shown on the display as $\boxed{E-OFF}$. Counts down the time left in the “Off” cycle. (timed dose only)

Green Pump Run Indicator(s) - Illuminates when pump(s) are called to run.

Viewing Panel Settings (Simplex)

With control power supplied to panel:

Press menu/enter button to scroll to the desired display screen.

Float Status or Float Error - the display shows \boxed{FS} or \boxed{FE} then float status. \boxed{C} =closed \boxed{O} =open

Elapsed Time Count - the display shows $\boxed{EE.1}$ then alternates showing hours (hh) then minutes (:mm).

Cycle Count - the display shows $\boxed{CC.1}$ then the count.

High Level & Power Fail Alarms - the display shows $\boxed{AL.CE}$ then the count.

Float Error Count - the display shows $\boxed{FE.CE}$ then the count.

Auxiliary Alarm Input Counts - the display shows \boxed{ALI} then the count.

TIMED DOSE DISPLAY ONLY

Timer Override Count - the display shows $\boxed{EO.CE}$ then the count.

ON Time - the display flashes \boxed{On} then the ON time in mm:ss.

Off Time - the display flashes \boxed{OFF} then the Off time in hh:mm.

Remaining ON/OFF Times - the display flashes either $\boxed{E-On}$ or $\boxed{E-OFF}$ then the time left in the On cycle (mm:ss) or OFF cycle (hh:mm).

Programming Panel Setting (Simplex):

With control power supplied to panel:

Press set/change button for 3 seconds to enter program mode.

The display will show \boxed{On} time in mm:ss.

Press set/change button to set the pump On time. Use the menu/enter button to select digit desired to change. Use the set/change button to change On time.

Press menu/enter button. The display will show \boxed{OFF} time in hh:mm.

Press set/change button to set the pump Off time. Use the menu/enter button to select digit desired to change. Use the set/change button to change Off time.

Note: Setting the \boxed{OFF} times to $\boxed{00:00}$ turns off timed dose mode and timed dose menu items. The panel will operate in demand mode. \boxed{On} time must be set higher than $\boxed{00:00}$ for demand dose to function.

Press set/change button for 3 seconds to return to the view menu.

Viewing Panel Settings (Duplex)

With control power supplied to panel:

Press menu/enter button to scroll to the desired display screen.

Float Status or Float Error - the display shows \boxed{FS} or \boxed{FE} then float status. \boxed{C} =closed \boxed{O} =open

Pump 1 Elapsed Time Count - the display shows $\boxed{EE.1}$ then alternates showing hours (hh) then minutes (:mm).

Pump 1 Cycle Count - the display shows $\boxed{CC.1}$ then the count.

Pump 2 Elapsed Time Count - the display shows $\boxed{EE.2}$ then alternates showing hours (hh) then minutes (:mm).

Pump 2 Cycle Count - the display shows $\boxed{CC.2}$ then the count.

High Level & Power Fail Alarms - the display shows $\boxed{AL.CE}$ then the count.

Float Error Count - the display shows $\boxed{FE.CE}$ then the count.

Auxiliary Alarm Input Counts - the display shows \boxed{ALI} then the count.

Lag Float Count - the display shows $\boxed{L.R.GC}$ then the count.

Programming Panel Setting (Duplex)

With control power supplied to panel:

Press set/change button for 3 seconds to enter program mode.

The display will show \boxed{ALEr} then either \boxed{ALE} , $\boxed{1-2}$ or $\boxed{2-1}$.

Press set/change button to set the desired pump sequence.

Press menu/enter button to display $\boxed{3FLt}$ or $\boxed{4FLt}$.

Press set/change button to choose $\boxed{3FLE}$ or $\boxed{4FLE}$.

Press menu/enter button.

Press set/change button for 3 seconds to return to the view menu.

Troubleshooting

Float Controls

1. Check the floats during their entire range of operation. Clean, adjust, replace and repair damaged floats.
2. Measure the float resistance to determine if the float is operating properly.

To measure float resistance:

- a. Isolate the float by disconnecting one or both of the float leads from the float terminals.
- b. Place one ohmmeter lead on one of the float wires, and the other ohmmeter lead on the other float wire.
- c. Set the ohmmeter dial to read ohms and place on the R X 1 scale. With the float in the "off" position, the scale should read infinity (high resistance), if not replace the float.

With the float in the "on" position, the scale should read close to zero, if not replace the float. **Readings may vary depending on the accuracy of the measuring device.**

Alarm Light

With power on, hold the test/silence switch in the "test" position. The alarm light should turn on. If not, replace the bulb with that of the same type.

Alarm Horn

With power on, hold the test/silence switch in the "test" position. The alarm horn should turn on. If not, replace the horn with that of the same type.

SJE-Rhombus® Five-Year Limited Warranty

SJE-RHOMBUS® warrants to the original consumer that this product shall be free of manufacturing defects for five years after the date of consumer purchase. During that time period and subject to the conditions set forth below, **SJE-RHOMBUS®** will repair or replace, for the original consumer, any component which proves to be defective due to defective materials or workmanship of **SJE-RHOMBUS®**.

ELECTRICAL WIRING AND SERVICING OF THIS PRODUCT MUST BE PERFORMED BY A LICENSED ELECTRICIAN.

THIS WARRANTY DOES NOT APPLY: (A) to damage due to lightning or conditions beyond the control of **SJE-RHOMBUS®**; (B) to defects or malfunctions resulting from failure to properly install, operate or maintain the unit in accordance with printed instructions provided; (C) to failures resulting from abuse, misuse, accident, or negligence; (D) to units which are not installed in accordance with applicable local codes, ordinances, or accepted trade practices, and (E) to units repaired and/or modified without prior authorization from **SJE-RHOMBUS®**.

Some states do not allow limitations on how long an implied warranty lasts, so the above limitation may not apply to you. Some states do not allow the exclusion or limitation of incidental or consequential damages, so the above limitation or exclusion may not apply to you. This warranty gives you specific legal rights, and you may also have other rights which vary from state to state.

TO OBTAIN WARRANTY SERVICE: The consumer shall assume all responsibility and expense for removal, reinstallation, and freight. Any item to be repaired or replaced under this warranty must be returned to **SJE-RHOMBUS®**, or such place as designated by **SJE-RHOMBUS®**.

ANY IMPLIED WARRANTIES OF MERCHANTABILITY OR FITNESS ARE LIMITED TO THE DURATION OF THIS WRITTEN WARRANTY. SJE-RHOMBUS® SHALL NOT, IN ANY MANNER, BE LIABLE FOR ANY INCIDENTAL OR CONSEQUENTIAL DAMAGES AS A RESULT OF A BREACH OF THIS WRITTEN WARRANTY OR ANY IMPLIED WARRANTY.

NOTICE!

Products returned must be cleaned, sanitized, or decontaminated as necessary prior to shipment to ensure that employees will not be exposed to health hazards in handling said material. All applicable laws and regulations shall apply.