

# PS Patrol® System with 120V Alarm Installation Instructions

**⚠ WARNING!**  
**ELECTRICAL SHOCK HAZARD**  
 Disconnect all power sources before servicing. Failure to do so could result in serious injury or death.

This control panel must be installed and serviced by a licensed electrician in accordance with the National Electric Code NFPA-70, state and local electrical codes.

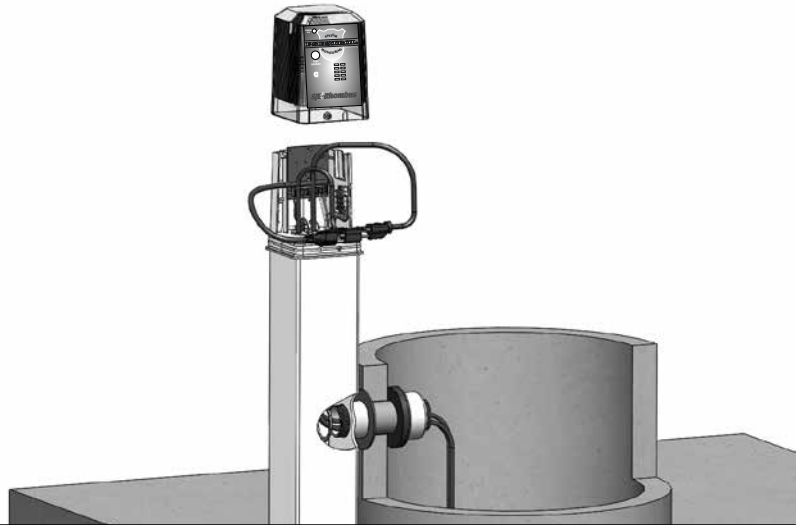

## Installation Instructions

Figure 1

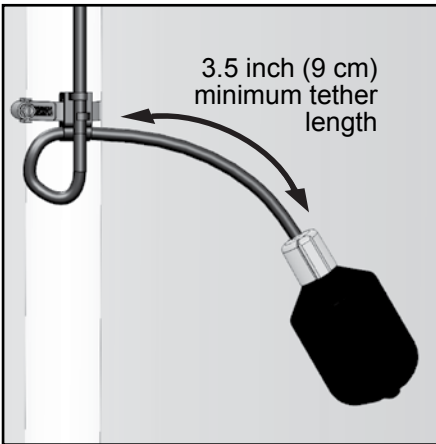

Install alarm float and pump float.  
(Mounting Clamp detail)

Figure 2

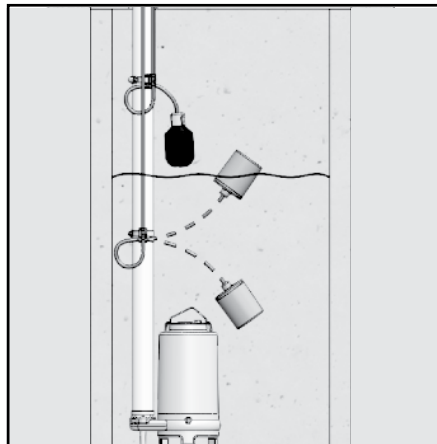

Wide angle\* float system.  
 \*SJE PumpMaster®, SJE PumpMaster® Plus,  
 or Super Single® pump switches

Figure 3

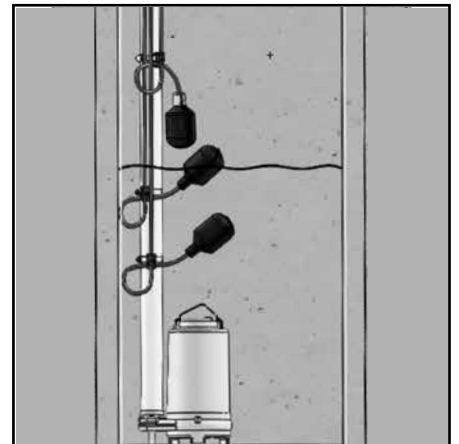

SJE Double Float® Master and Double  
 Float® pump switches

### DETERMINING PUMPING RANGE (IN INCHES)

Super Single® pumping range	tether length	3.5	5	7	9	11	13	15
	pumping range	6.5	7.5	8.5	10	11	12.5	13.5
SJE PumpMaster® & SJE PumpMaster Plus® pumping range	tether length	3.5	6	10	9	14	18	22
	pumping range	7	10	16	22	28	33	36

Use only as a guide. Pumping ranges are based on testing in non-turbulent conditions.  
 Range may vary due to water temperature and cord shape.

**Note:** As the tether length increases, so does the variance of the pumping range.

# SJE Rhombus®

22650 County Highway 6 ■ P.O. Box 1708 ■ Detroit Lakes, Minnesota 56502 USA  
 1-888-DIAL-SJE (1-888-342-5753) ■ Phone: 218-847-1317 ■ Fax: 218-847-4617  
 E-mail: customer.service@sjerrhombus.com ■ Website: www.sjerrhombus.com

# Installation Instructions

Figure 4

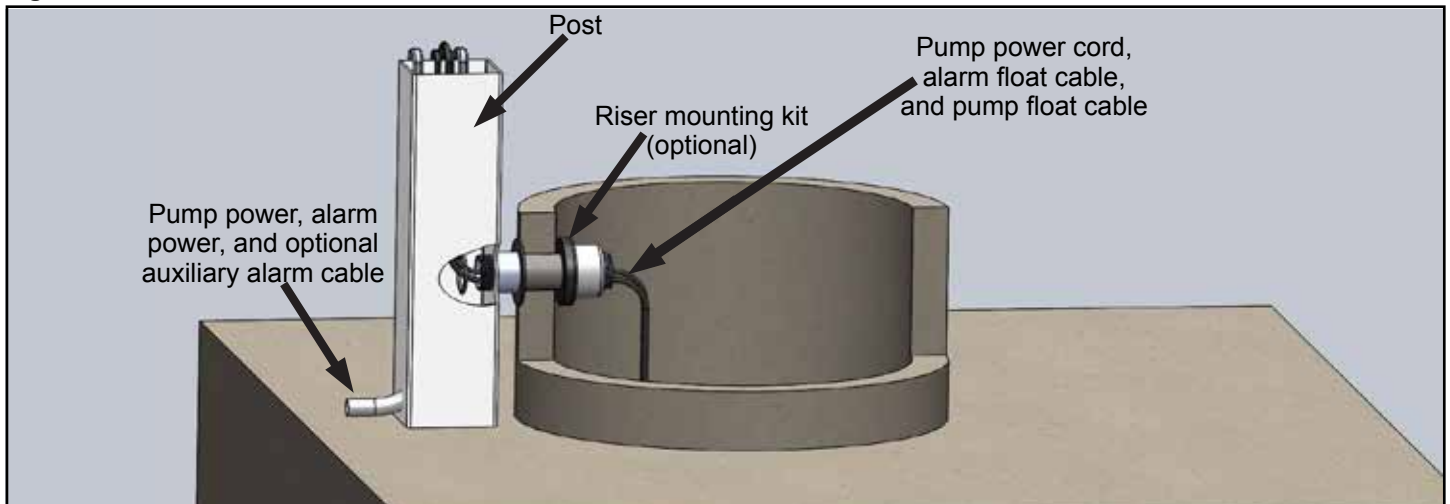

Run cables through optional riser mounting kit and post.

Figure 5

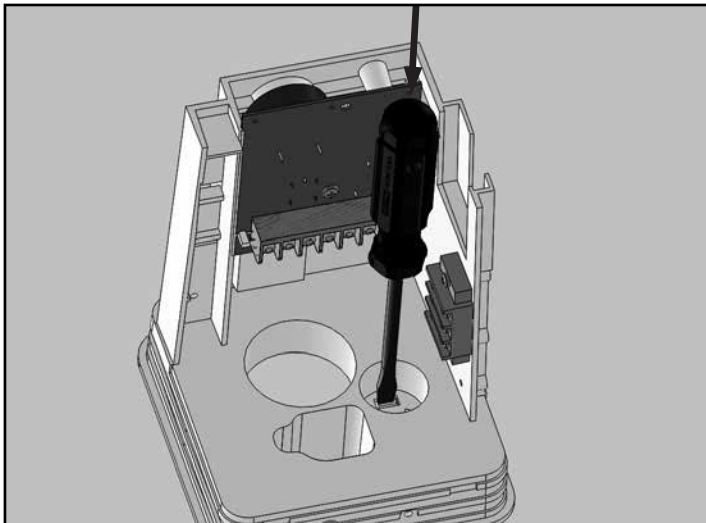

Punch out power cable knock outs as shown.

**Note:** Only remove knock outs for number of cables used.

Figure 6

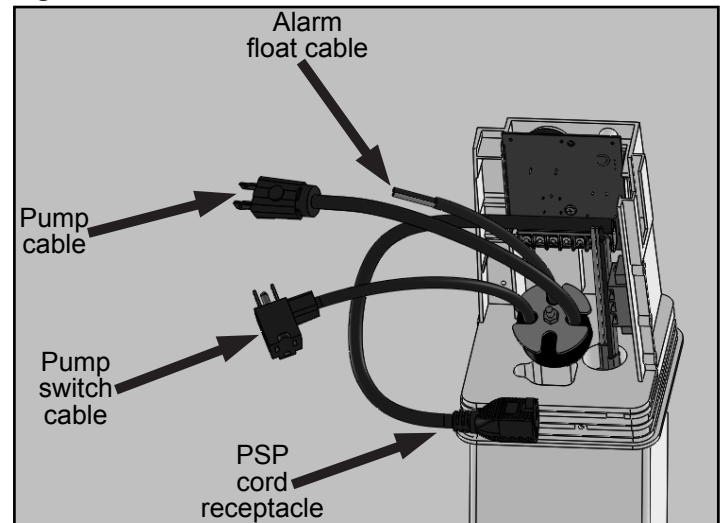

Holding base, run cables through cord seal holes.

Figure 7

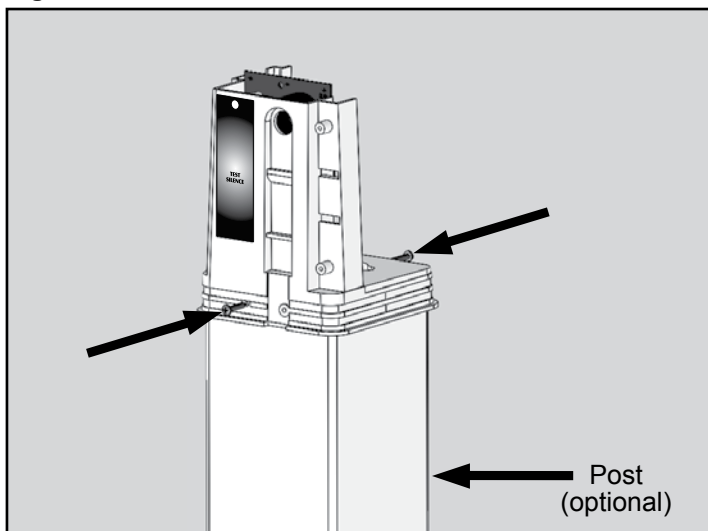

Mount PS Patrol® to post. **Note:** PS Patrol® can be mounted to optional square plastic post as shown in **Figure 7** or 4 inch conduit / PVC Pipe (customer supplied) as shown in **Figure 8**. Use #8 x 1" screws only.

Figure 8

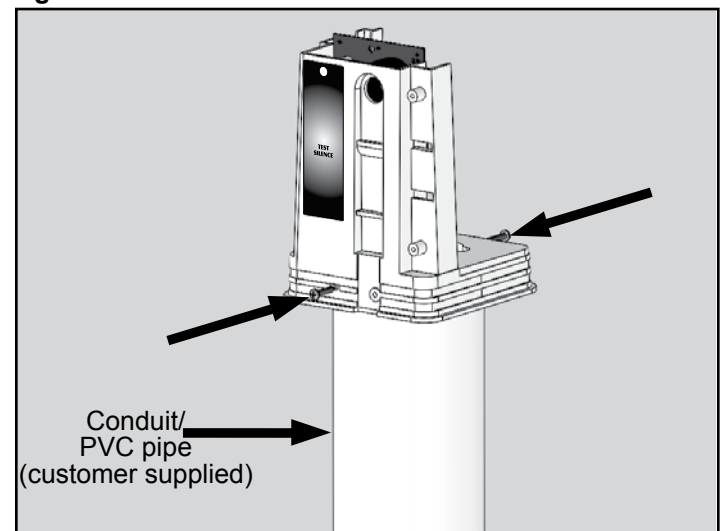

# Installation Instructions

Figure 9

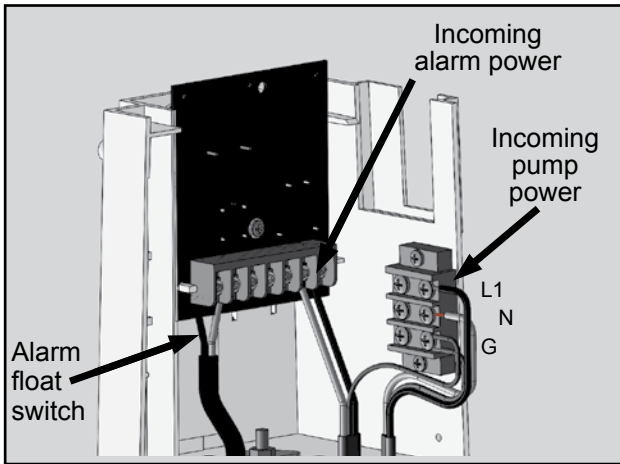

Connect alarm power, pump power and alarm float switch as shown.

Figure 10

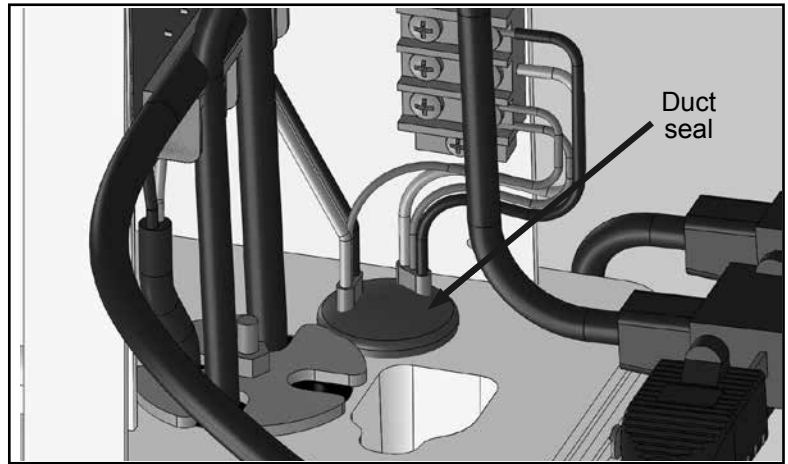

Use electrical duct seal to fill around incoming power cords. Ensure pocket is filled completely and the gaps filled around each cable.

**WARNING:** Failure to do so will allow sewer gases to enter control panel causing corrosion and failure of electrical components.

Figure 11

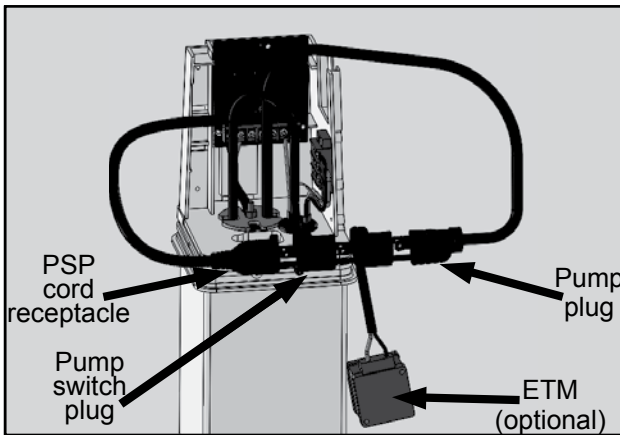

Plug pump switch piggy-back plug into PSP cord receptacle. If using optional ETM, plug this into back of pump switch piggy-back plug. Plug pump in last.

**WARNING:** Failure to have the plugs in order described as shown will effect proper operation of system.

Figure 12

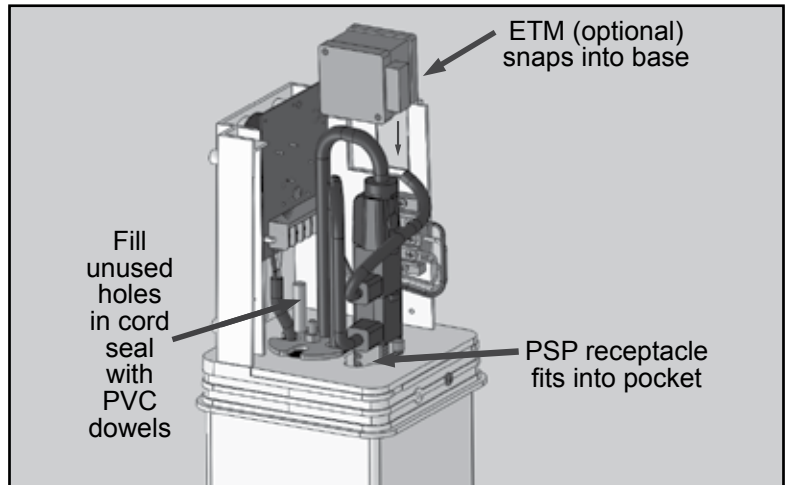

If ETM is used, snap into location as shown. Arrange cords as shown. Receptacle is inserted into pocket. Push excess cord back through cord seal. Install PVC dowels into unused holes of cord seal.

Figure 13

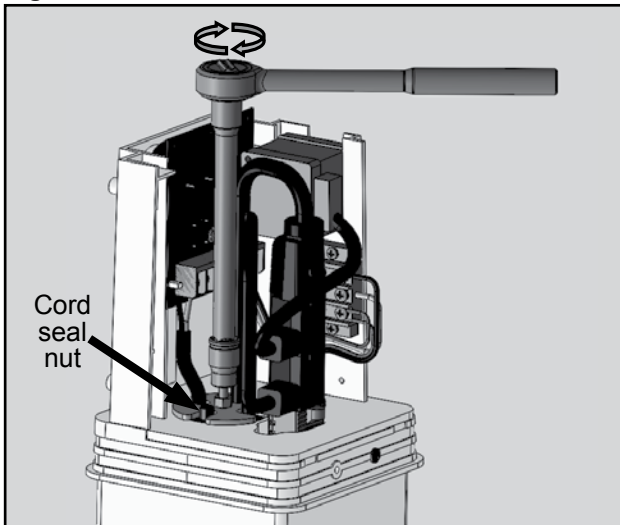

Firmly tighten cord seal nut so that cables do not move and cord seal is held in place.

Figure 14

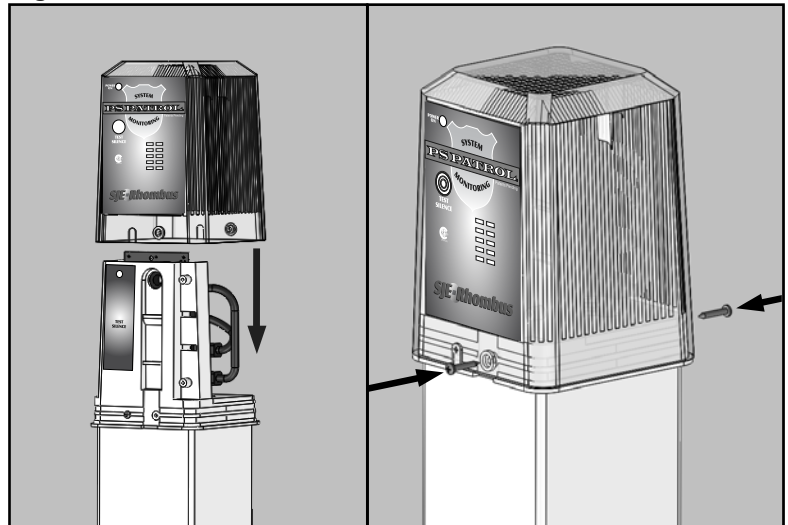

Install cover on base and screw into place.

# Installation Instructions



## WARNING!



### ELECTRICAL SHOCK HAZARD

Disconnect all power sources before servicing. Failure to do so could result in serious injury or death.

Figure 15

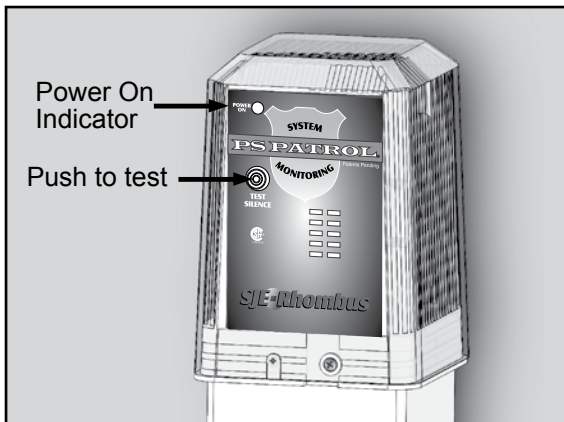

Turn on power and test alarm by pressing the test silence switch. Horn will sound and alarm light will illuminate.

Figure 16

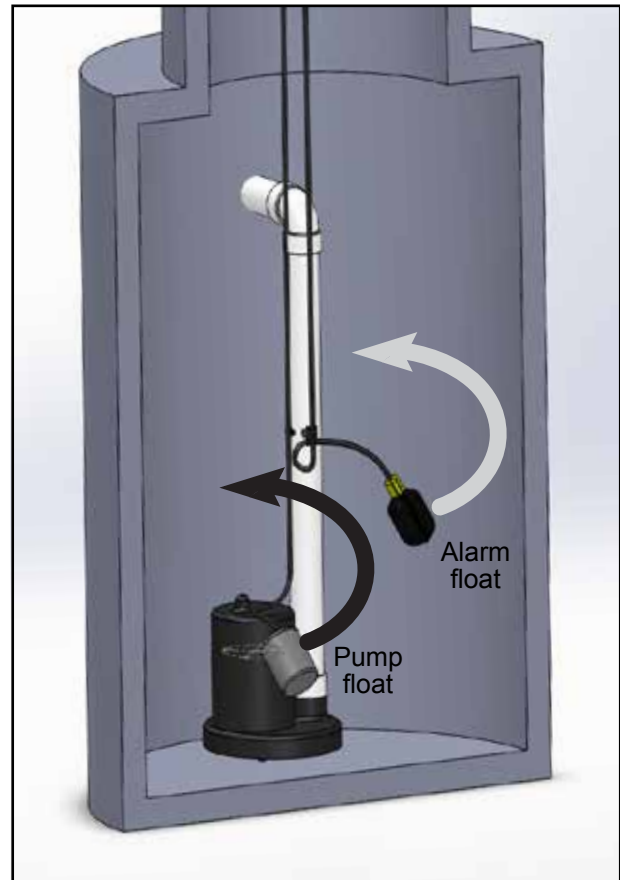

Perform final testing on system by lifting pump and alarm float. When pump float is lifted, the pump will turn on. When alarm float is lifted, the alarm horn will sound and alarm light will illuminate.

## SJE-Rhombus® Five-Year Limited Warranty

**SJE-RHOMBUS®** warrants to the original consumer that this product shall be free of manufacturing defects for five years after the date of consumer purchase. During that time period and subject to the conditions set forth below, **SJE-RHOMBUS®** will repair or replace, for the original consumer, any component which proves to be defective due to defective materials or workmanship of **SJE-RHOMBUS®**.

**ELECTRICAL WIRING AND SERVICING OF THIS PRODUCT MUST BE PERFORMED BY A LICENSED ELECTRICIAN.**

**THIS WARRANTY DOES NOT APPLY:** (A) to damage due to lightning or conditions beyond the control of **SJE-RHOMBUS®**; (B) to defects or malfunctions resulting from failure to properly install, operate or maintain the unit in accordance with printed instructions provided; (C) to failures resulting from abuse, misuse, accident, or negligence; (D) to units which are not installed in accordance with applicable local codes, ordinances, or accepted trade practices, and (E) to units repaired and/or modified without prior authorization from **SJE-RHOMBUS®**.

*Some states do not allow limitations on how long an implied warranty lasts, so the above limitation may not apply to you. Some states do not allow the exclusion or limitation of incidental or consequential damages, so the above limitation or exclusion may not apply to you. This warranty gives you specific legal rights, and you may also have other rights which vary from state to state.*

**TO OBTAIN WARRANTY SERVICE:** The consumer shall assume all responsibility and expense for removal, reinstallation, and freight. Any item to be repaired or replaced under this warranty must be returned to **SJE-RHOMBUS®**, or such place as designated by **SJE-RHOMBUS®**.

**ANY IMPLIED WARRANTIES OF MERCHANTABILITY OR FITNESS ARE LIMITED TO THE DURATION OF THIS WRITTEN WARRANTY. SJE-RHOMBUS® SHALL NOT, IN ANY MANNER, BE LIABLE FOR ANY INCIDENTAL OR CONSEQUENTIAL DAMAGES AS A RESULT OF A BREACH OF THIS WRITTEN WARRANTY OR ANY IMPLIED WARRANTY.**

### NOTICE!

Products returned must be cleaned, sanitized, or decontaminated as necessary prior to shipment to ensure that employees will not be exposed to health hazards in handling said material. All applicable laws and regulations shall apply.