

# Quanics

Engineering **Water Solutions**™

P.O. BOX 1520  
6244 OLD LAGRANGE ROAD  
CRESTWOOD, KY 40014  
www.quanics.net

PHONE: (502) 992-8200  
1-877-QUANICS  
FAX: (502) 992-8201

CLASS I / NSF STD 40  
WASTEWATER TREATMENT SYSTEM



## **INSTALLATION MANUAL**

MANUFACTURED  
PRODUCTS  
BY:

**QUANICS™**

FIXED FILM MEDIA  
WASTEWATER TREATMENT SYSTEMS

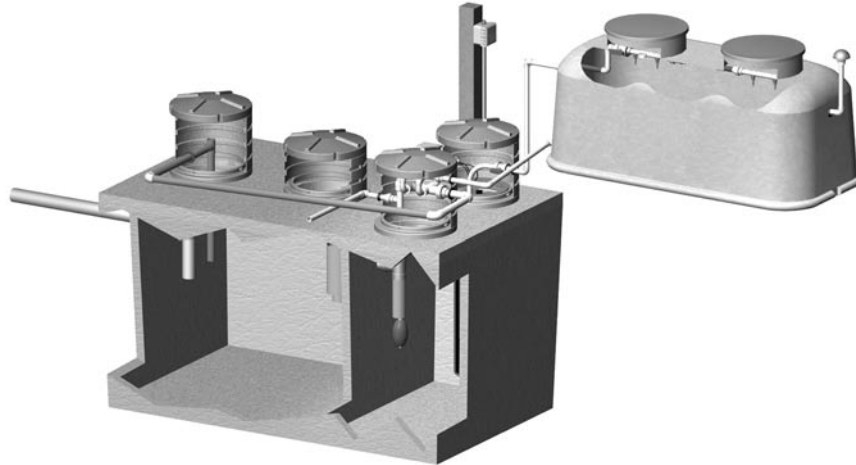

**Table of Contents**

INTRODUCTION	2
PROCESS DESCRIPTION	2
COMPONENTS LIST	3
INSTALLATION	3
Section 1.0      Septic/Dosing Tank	3
Section 2.0      A300-8" Series Effluent Filter	4
Section 3.0      Filtered Pump Vault	4
Section 4.0      Effluent Discharge	4
Section 5.0      Control Panel/Junction Box	5
Section 6.0      Recirculation Device	6
Section 7.0      Treatment Module	6
START UP PROCEDURE	7
SAFETY	7
TECHNICAL DATA/DRAWINGS	7-18
WIRING SCHEMATICS	19-20
DATA PLATES	20

## INTRODUCTION

**QUANICS™** is committed to becoming the best water solutions problem solver in the world. We promise to provide complete engineered water solutions using the latest technology and best products. We will provide the best technical assistance and customer service available and we will always deliver more than we promise.

In our quest to serve our market, we do not view a technology as the one and only option, but rather look to develop a wide variety of technologies that the engineer and/or end user can tailor to their individual application. Along this line, we are proud to introduce two NSF Certified treatment systems, SCAT® **AeroCell®** and SCAT **Bio-COIR™**.

Both systems operate as fixed-film media filters to treat wastewater. The patented SCAT delivery system is the same for each system only the media is different. Each media type has its own unique properties and both have been tested and listed under NSF International Standard 40 Class 1 requirements. Both systems have also been demonstrated to significantly reduce total nitrogen. The following manual will explain the differences and similarities of each system. Before reading this manual determine which system you are currently utilizing by examining the data plate attached to the system lid. Each system will be identified by name "**Bio-COIR**" or "**AeroCell**".

This manual covers the following model numbers.

<b>AeroCell Model #'s</b>	<b>Bio-COIR Model #'s</b>
ATS-SCAT-8-AC-C500	ATS-SCAT-8-BC-C500
ATS-SCAT-86-AC-C750	ATS-SCAT-86-BC-C750
ATS-SCAT-88-AC-C1000	ATS-SCAT-88-BC-C1000
ATS-SCAT-886-AC-C1250	ATS-SCAT-886-BC-C1250
ATS-SCAT-888-AC-C1500	ATS-SCAT-888-BC-C1500

We are eager to assist you with any questions or problems. Please contact **QUANICS** at 1-877-QUANICS to request assistance.

## PROCESS DESCRIPTION

The **QUANICS AeroCell & Bio-COIR** are individual wastewater treatment systems utilizing fixed film media. The module(s) consist of a fiberglass tank(s) containing a pre-determined amount of media. Effluent is sprayed over the media utilizing specialized spray nozzles. This patented delivery system evenly distributes wastewater to achieve the desired treatment levels.

The **AeroCell** utilizes open cell foam media. The foam has a high porosity, large surface area and ease of microbial attachment that allows for loading rates up to ten times that of sand. Open cell foam has a fifteen year track record of treating wastewater to the highest quality treatment levels. The application rates for the **AeroCell** system have been carefully selected to provide optimal treatment and performance in a long lasting media.

The **Bio-COIR** utilizes a patent pending **Bio-COIR** media for treatment. The **Bio-COIR** media is composed of fibers that constitutes the thick mesocarp, or husk, of the coconut fruit. The long fibers are used for ropes, door mats etc, leaving pith tissue and short to medium length fibers as a waste which has accumulated in heaps in many third world countries. The short to medium length **Bio-COIR** fibers used in **Bio-COIR** are a lingocellulosic material. The high lignin content of these fibers results in a more durable material than other natural medias. The high lignin content of 45.84% also results in a slower degradation of the media and assures that excellent water/air ratio is maintained over a longer period of time.

In both **AeroCell & Bio-COIR** systems, pretreatment of the wastewater occurs through the use of a septic tank equipped with a Zabel® A300 series effluent filter on the outlet. The pretreated wastewater then moves into a dosing tank where an effluent pump doses the wastewater to the treatment module(s). The dosing of effluent occurs in short frequent doses over a 24-hour period utilizing a timed dosed control panel. Effluent is sprayed over the media through the use of specially designed helical spray nozzles that provide uniform distribution of the effluent over the entire surface area.

Once sprayed, the effluent moves via gravity down through the media where it is allowed to come into contact with beneficial microorganisms that serve to treat the effluent to NSF International Standard 40 Class 1 requirements. After passing through the full depth of media the effluent travels to the **QUANICS** ATS-GRD-100/80/20 recirculation device. The recirculation device splits the flow and discharges 80% back into the treatment stream and 20% to the final disposal point. In periods of low flow, 100% of the treated effluent discharges back into the treatment stream.

## COMPONENT LIST

Following are all the parts needed to complete the installation of models ATS-SCAT-AC-C500 **AeroCell**<sup>®</sup> and the ATS-SCAT-BC-C500 **Bio-COIR**<sup>™</sup> systems. Should any part(s) be missing, off specification, or if you encounter any problems call **QUANICS**<sup>™</sup> at 1-877-QUANICS.

Item:	Description:	Quantity:
1. A300-8x18-VC	Effluent Filter	1 ea.
2. FPV-H44-4	Filtered Pump Vault	1 ea.
3. P-SE-13T	1/3 hp Effluent Pump	1 ea.
4. PDS-ED-1.5	1.5" Effluent Discharge	1 ea.
5. PDS-GT-1.5	1.5" Grommet	2 ea.
6. AC-FT-3	Float Tree	1 ea.
7. AC-JSB-4	Junction Box	1 ea.
8. AC-CP-S-C-T	Simplex Timed Dose Panel	1 ea.
9. ATS-GRD-100/80/20	Recirculation Device	1 ea.
10. RB-CTA-26x6	Cast-in Tank Adapter	4 ea.
11. RB-R-26x18	26" x 18" Riser	3 ea.
12. RB-L-26	26" Lid	3 ea.
13. ATS-SCAT-8-AC-C500 or	<b>AeroCell</b> Module	1 ea. (one 8' tank)
14. ATS-SCAT-8-BC-C500	<b>Bio-COIR</b> Module	1 ea. (one 8' tank)

The parts in the components list include all the parts necessary for completion of the **QUANICS AeroCell** and **Bio-COIR** Class I treatment systems with the exception of the septic and dosing tanks and the final disposal/dispersal system. Additional risers may be required to bring access to grade. By following these simple instructions, your assembly of the system will be completed in minimum time and with the assurance of a properly functional module.

## INSTALLATION

The **AeroCell** and **Bio-COIR** systems must be installed according to these instructions. Any modifications to the system will result in loss of warranty and invalidation of the plant's NSF certification. Remove the outer packaging material from the module(s). If installing a **Bio-COIR** system, attach a lifting mechanism to the eye bolts on top of the module(s) and set in place. No particular instructions are required for unpacking the remaining components from their delivery cartons.

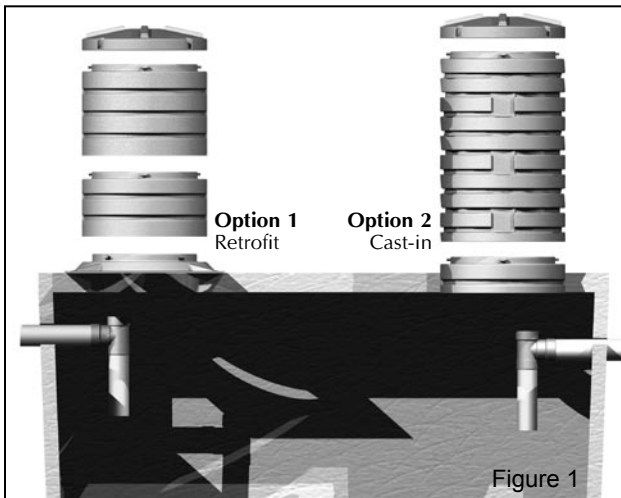

### Section 1.0 Septic/Dosing Tank

The tanks should be installed level and on a stable base to reduce the possibility of settling. It shall be constructed so as to not allow infiltration or exfiltration. It shall be installed to allow gravity flow into the tank. The inlet and outlet shall be sealed and rendered watertight. Please follow the guidelines and practices as required by the local regulatory authority.

**QUANICS'** twenty-six (26) inch diameter extension riser(s) must be used to bring access above grade (**figure 1**). The riser must be above grade to provide system access. The extension riser on treatment modules may be any reasonable depth. Under no circumstances shall the **QUANICS** access cover be buried.

Backfill the excavation using a material that will settle well around the tanks. Do not use large rocks or heavy clay. Place the material around the tanks in layers, tamping and watering each layer.

Before the installation is complete, the **QUANICS** access cover must be in place and the tamper-resistant screws (**figure 2**), provided by **QUANICS**, must be installed and properly tightened to prevent unauthorized personnel from gaining entry inside the tank.

Note: The tank must be filled to the outlet/overflow with water after installation to prevent hydrostatic displacement (floating of tanks).

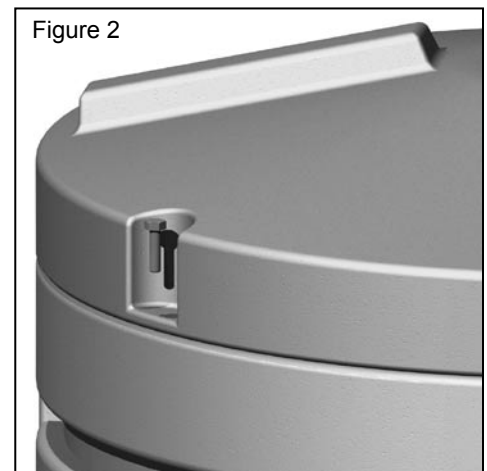

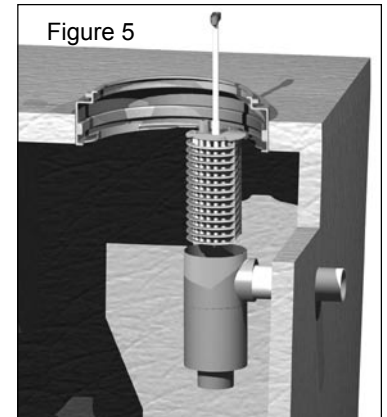
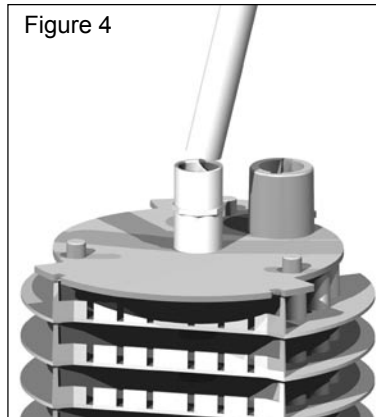
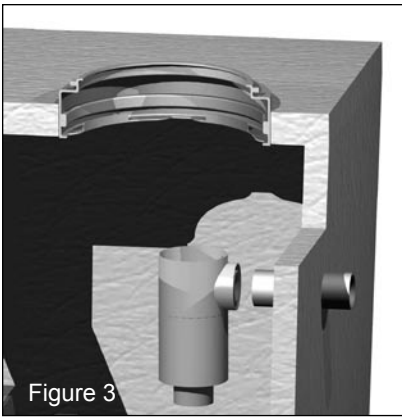

### Section 2.0 A300-8x18-VC & A300-8x26-VC Effluent Filters

1. Before installation, dry fit the filter case (**figure 3**) on the outlet pipe of the primary septic tank to make sure it will be centered under the access opening. If not, solvent weld (glue) additional pipe to the outlet pipe so that the filter case will be centered.
2. Solvent weld the filter case onto the SCH 40 outlet pipe.
3. Solvent weld the filter handle to the top plate of the filter cartridge. Extend the handle, as required, to make it accessible from surface grade (**figure 4**).
4. Insert the filter cartridge into the case, making sure the filter cartridge is properly aligned and completely inserted into the case (**figure 5**).

### Section 3.0 Filtered Pump Vault

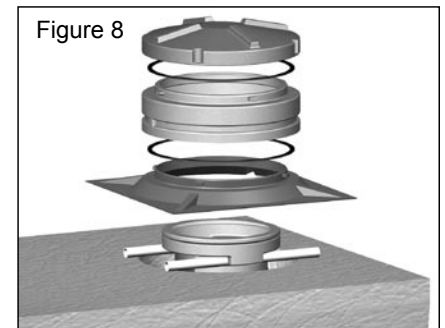
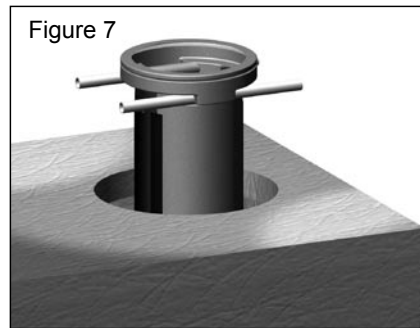
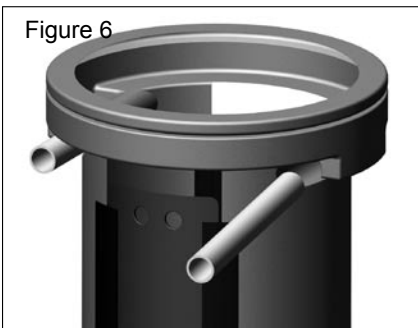

1. Thread 1-1/2" SCH 40 PVC through the handles to bridge the access opening in the dosing tank (**figure 6**).
2. Lower the pump vault through the outlet access opening in the dosing tank and allow it to rest on the tank or access riser (**figure 7**).
3. Remove the white maintenance plate from the inside of the filtered pump vault. Do not discard. The maintenance plate may be stored inside the access riser.
4. Add additional access risers as needed to bring to surface grade (**figure 8**).

### Section 4.0 Effluent Discharge

1. Thread the SCH 40 PVC threaded male adapter into the discharge of the pump (**figure 9**). Use Teflon tape or plumbers putty on the threads to insure leak-proof fit. Insert hard PVC pipe into the male adapter (**figure 10**). **This section of PVC pipe may be adjusted to desired height.**
2. Attach the SCH 40 PVC slip/slip adapter on the hard PVC pipe coming from the pump (**figure 11**). Insert the PVC flex pipe into the slip/slip adapter (**figure 12**).
3. Cut the PVC flex tubing and attach the true union ball valve so that it is located in the middle of the riser and accessible from the top (**figure 13**). Drill the appropriate sized hole in the riser (2.5" hole for 1.5" discharge,

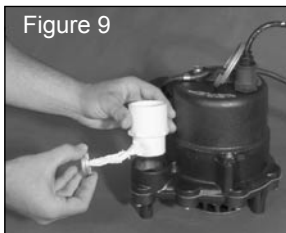

and 3" hole for the 2" discharge assembly) (figure 14).

4. Insert the grommet into the drilled hole. Insert the cut section of PVC flex tubing through the grommet from outside (figure 15). \*Lubricant may be necessary. Then, insert the flex tubing into the discharge side of the true union ball valve (figure 16). Attach the outlet side of the flex pipe to the distribution assembly (not provided).

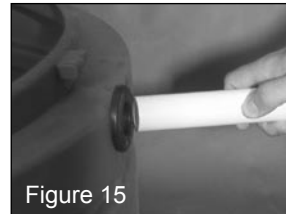
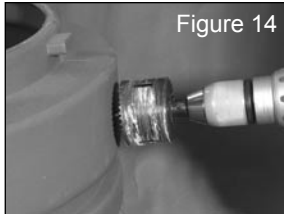

**\*Note:** Window cleaner in a spray bottle makes an excellent grommet lubricant.

**Optional** - If a check valve is used, drill a 1/8" hole in the discharge above the waterline and below the check valve.

## Section 5.0 Control Panel/Junction Box

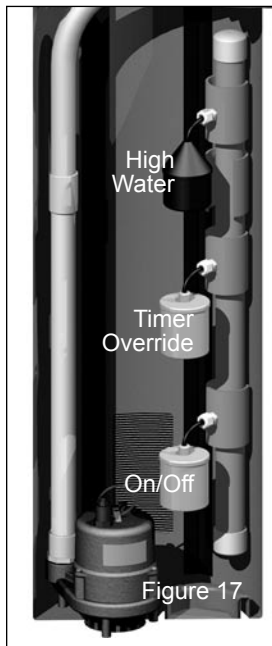

1. Use the float labels included to identify each float as per figure 17.
2. Determine your normal operating level and float configuration as illustrated in Figures 1-4 on the installation sheet in the panel box. (Note: **QUANICS™** recommends the three float system with timer override and no redundant off.) (figure 17)
3. Mount the floats at appropriate levels on the float tree using the strain relief cable connectors to set the tether length. Be sure that the floats have free-range motion without touching each other or other equipment.

### Mounting the Control Panel and Junction Box

1. Determine the mounting location for the panel. If the distance exceeds the length of the float switch cables or pump power cables, use the junction box with liquid-tight connectors to splice the cables. You must use conduit sealant to prevent moisture or gases from entering the panel. (figure 18)
2. Mount the control panel with the mounting devices furnished.
3. Determine conduit entrance locations on the control panel. (Check codes and schematic for the number of power circuits required).

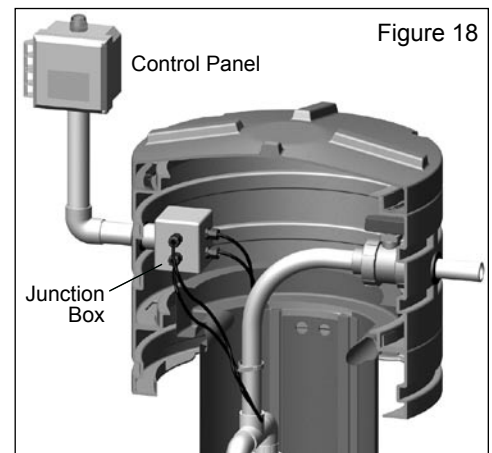

4. Drill the proper size holes for the type of connections being used. (Note: Be sure that the conduit is of adequate size to pull the pump and switch cables through).
5. Attach the cable connectors and/or conduit connectors to the control panel.
6. Connect the pump wires and float switch cables to the proper terminals as seen in Figures 6 & 7 in accompanying installation instructions with the control panel.
7. Connect the pump/control and alarm incoming power conductors to the proper position on the terminals. See the schematic and wiring diagram for terminal connections.
8. If using a junction box, determine the mounting location according to local code requirements.
9. If mounting the junction box on the inside of the riser, cut a 2-1/2 inch hole in the riser. Insert a 1-1/2 inch grommet (PDS-GT-1.5) in the hole and a 1-1/2 inch conduit through the grommet. Glue the junction box to the pipe.
10. Identify each wire before pulling them through the pipe to the junction box. Make wire splice connections in the junction box.

### Setting the Timer

**Refer to Figure 8 in the accompanying installation instructions included with the panel.**

1. Determine the pump on and off time and turn the adjustment screw (1) so that the most appropriate range of numbers is visible on the dial face. (see timer setting chart below)
2. Adjust the time range selector (2) to the appropriate period. (e.g. minutes)
3. Adjust the outer dial (3) so that the green pointer indicates the off time period required.
4. Adjust the timer range selector (4) to the appropriate period. (e.g. minutes)
5. Adjust the inner dial (5) so that the red pointer indicates the on time period required.
6. The cycle would continue as long as there is enough liquid in the tank to float the low level cutoff switch.

Note: Green is off and Red is on.

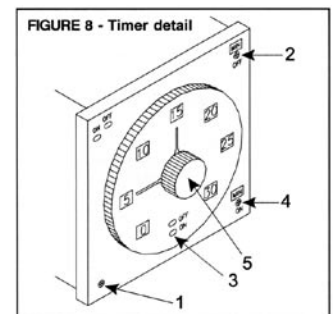

### Timer Settings

Gallons Per Day	ON (Minutes)	OFF (Minutes)
500	2	13
750	2	18
1000	2	13
1250	2	16
1500	2	13

## Section 6.0 Recirculation Device

1. The ATS-GRD-100/80/20 recirculation device comes partially assembled:
  - a. The device is housed in an 18-inch tall 26-inch diameter polyethylene **QUANICS™** riser.
  - b. It includes a 26-inch lid and neoprene gasket kit.
2. There are two 1-1/4 inch PVC pipes going through the riser. To reassemble the device, do the following:
  - a. Lower the entire recirculation assembly into the riser and line up the upper and lower recirculation pipes with the corresponding pipes on the assembly. The red float goes down.
  - b. Reattach the assembly with the threaded unions and level the device (two crosses/four outfalls). Secure hand tight.

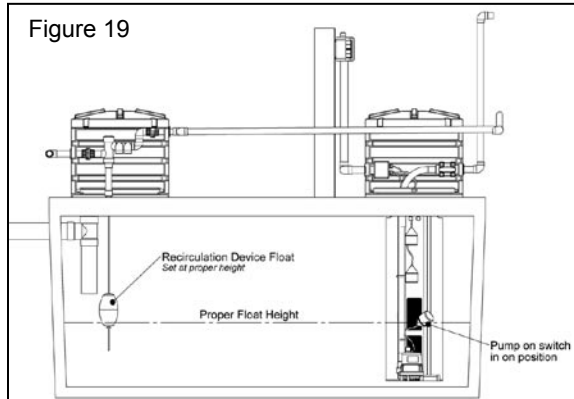
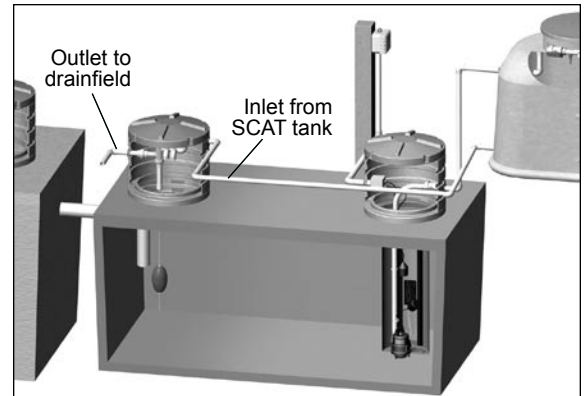

- c. Adjust the float on the steel rod by sliding it up or down. When the float is at its lowest position, it should be located equal to or just above the on position of the timer enable float. Tighten the collars holding the float in place. **(figure 19)**
3. The riser is ready to be attached to the tank:
  - a. The riser containing the recirculation assembly must be attached to the tank by using a **QUANICS** retrofit adapter (RB-RTA-26x2), **QUANICS** cast-in adapter (RB-CTA-26x2) or **QUANICS** riser already in place.
  - b. Apply the neoprene gasket according to package instructions on the receiving riser.
  - c. Lower the recirculation device down on the riser and twist to secure it.
4. Attach the pipes:
  - a. Attach 1-1/4 inch PVC pipe coming from the bottom (discharge) of the treatment module to the upper pipe going into the recirculation device.

Note: The module must be set so that gravity fall can be achieved from the bottom to the upper pipe in the recirculation device.

- b. Attach 1-1/4 inch PVC pipe from the lower pipe in the recirculation device and run it to the discharge point (drainfield, dosing tank for pressure distribution, etc.)
- c. Apply the neoprene gasket to the top of the recirculation riser and place the lid on it.
- d. Secure the lid with the security screws supplied.

## Section 7.0 Treatment Module

Each module arrives pre-plumbed on the inside with only a few simple connections required for installation. General guidelines for installing the module include the following:

1. Locate the module in an area that provides good ventilation and rainwater run-off. It may be placed directly on the pretreatment tank or it may be located in another area. Prepare an excavation with a width and depth that will allow any and all inlet/outlet connections. Ensure there is positive flow from the outlet of the module into the gravity recirculation device and then back into the primary tank. The access covers should extend above the final surface grade in such a way to prevent surface water from entering the module.
2. Using a transit-leveling instrument ensure the module is placed level and on a stable base. Remove any sharp objects or rocks from the bottom of the excavation or place four (4) inches of sand or fine-grained gradable material in the bottom of the excavation.
3. When the bottom of the excavation is graded, smooth, tamped and level, gently lower the module into the excavation **(figure 20)**.



4. Connect the pump discharge line to the 1-1/4" module inlet hub **(figure 21)**. All piping is SCH 40 and should be primed and glued using the proper PVC products.
5. The module may arrive with the nozzle discharge assembly disconnected to protect during shipping. Attach the nozzle discharge assembly to the corresponding true unions by threading the housing. Hand tighten each true union to prevent water leaks when the system is pressurized.
6. The nozzle is attached to the discharge



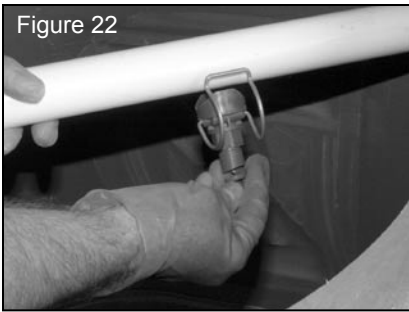

assembly via a clamp. Align the opening in the nozzle with the hole in the discharge assembly. Pull the clamp up and over the discharge assembly pipe locking it into place (**figure 22**).

7. Connect the recirculation line to the 1-1/4" module outlet hub. Attach the 1-1/4" vent pipe to the module venting hub. The included carbon filter vent may then be placed at any location. Ensure the carbon filter vent is above grade and protected. (**figure 23**)

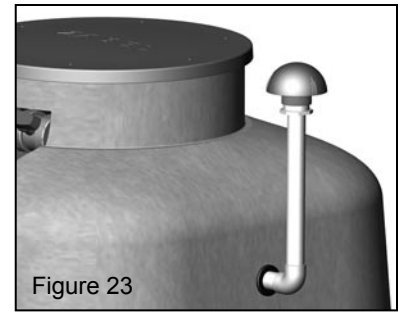

**START-UP PROCEDURE**

Once all the connections are made, remove the four spray nozzles by unclamping them from the discharge assembly. Turn on the pump to flush any debris from inside the discharge assembly. After flushing, turn off the pump and reinstall the nozzles by locating the nozzle over the discharge hole and sliding the nozzle clamp over the top of the discharge assembly. Turn the pump back on to pressurize the system to check for leaks and set the pressure gauge, mounted on the nozzle discharge assembly, to 5-8 psi using the ball valve attached to the assembly. Check all connections for leaks.

If the system is to remain idle for a period of time, please inform the owner that the system is operational. If any mechanical or electrical problems are experienced when attempting start-up, the owner should call the dealer for service and assistance in start-up of the plant.

**SAFETY**

As raw wastewater may and usually does contain some level of unsafe microorganisms, proper respect and care must be given to safety. When coming into contact with raw sewage, do not fear the contact, but do take proper precautions to avoid potential danger.

Follow these simple safety precautions whenever exposed to wastewater:

- \* Always wash with soap and water after handling any contaminated item. The use of good bactericide soap is strongly recommended.
- \* Wear disposable rubber gloves when handling wastewater-contaminated items or chlorine tablets.
- \* Always dispose of scum, rags, trash, debris, or soiled material in a proper waste container.
- \* If a wastewater spill or leak occurs in a yard, flush area with plenty of clean water and disinfect. If a spill or leak occurs in the house, clean with a dilute solution of bleach.
- \* Protect any injury, wound, open cut, etc. from exposure to wastewater.
- \* If an illness or disease is suspected of coming from exposure to sewage, get proper medical attention immediately.
- \* Report all accidents relating to sewage exposure to the proper supervisory personnel.

Follow these safety precautions when performing any excavation or construction work:

- \* Follow all construction safety procedures during installation.
- \* Follow electrical safety procedures during installation.
- \* Fill all holes and depressions in and around the installation area; remove and dispose of all debris from construction/installation.

**TECHNICAL DATA/DRAWINGS INDEX**

ATS-SCAT-8-AC-C500	8	PDS-ED-1.5	15
ATS-SCAT-86-AC-C750	8	PDS-GT-1.5	16
ATS-SCAT-88-AC-C100010	9	AC-FT-3	16
ATS-SCAT-886-AC-C1250	9	AC-JSB-4	17
ATS-SCAT-888-AC-C1500	10	AC-CP-S-C-T	17
ATS-SCAT-8-BC-C500	10	ATS-GRD-100/80/20	18
ATS-SCAT-86-BC-C750	11	ATS-GRD-100/80/20-N	18
ATS-SCAT-88-BC-C1000	11	RB-CTA-26x6	18
ATS-SCAT-886-BC-C1250	12	RB-R-26x18	18
ATS-SCAT-888-BC-C1500	12	RB-L-26	18
ATS-SCAT-6	13		
ATS-SCAT-8	13		
A300-8" Series Effluent Filter	14		
FPV-H44-4	14		
P-SE-13T	15		



**500 GPD AeroCell® System**  
[www.quanics.net/autocad.htm](http://www.quanics.net/autocad.htm)

ZONE		REV.		REVISIONS	DATE	APPROVED
				DESCRIPTION		

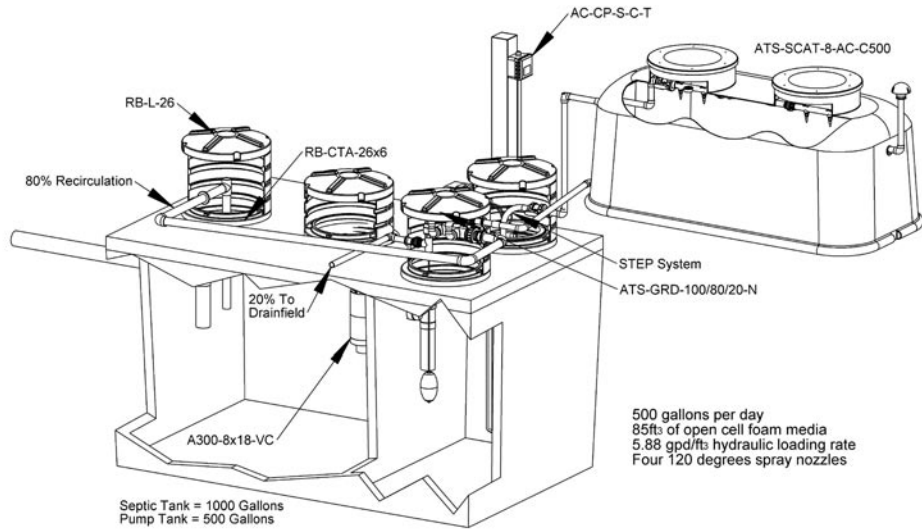

Septic Tank = 1000 Gallons  
 Pump Tank = 500 Gallons  
 The septic tank shall have a minimum L:W ratio of equal to or greater than one.

500 gallons per day  
 85ft of open cell foam media  
 5.88 gpd/fts hydraulic loading rate  
 Four 120 degrees spray nozzles

**Parts Included:**

- ATS-SCAT-8-AC-C500
- A300-8x18-VC
- FPV-H44-4
- P-SE-13T
- PDS-ED-1.5
- PDS-GT-1.25
- PDS-GT-1.5 (2x)
- AC-FT-3
- AC-JSB-4
- AC-CP-S-C-T
- ATS-GRD-100/80/20-N
- RB-CTA-26x6 (4x)
- RB-R-26x18 (3x)
- RB-L-26 (3x)

Product(s) covered by one or more U.S. and/or International patents. Other U.S. and International patents may be pending.

DIMENSIONS ARE IN INCHES		NAME	DATE	<b>QUANICS Incorporated</b>	
TOLERANCES:		DRAWN	TNJ		08-08-05
FRACTIONAL ±		CHECKED	BB		08-08-05
ANGULAR: MACH ± BEND ±		ENG APPR.			
TWO PLACE DECIMAL ±		MFG APPR.			
THREE PLACE DECIMAL ±		G.A.			
MATERIAL		COMMENTS:			
NEXT ASSY	USED ON	FINISH	--		
APPLICATION	SCALE	1 : 35			

SIZE <b>A</b>	DWG. NO. <b>ATS-SCAT-8-AC-C500</b>	REV.
WEIGHT:		SHEET 1 OF 1

**750 GPD AeroCell System**  
[www.quanics.net/autocad.htm](http://www.quanics.net/autocad.htm)

ZONE		REV.		REVISIONS	DATE	APPROVED
				DESCRIPTION		

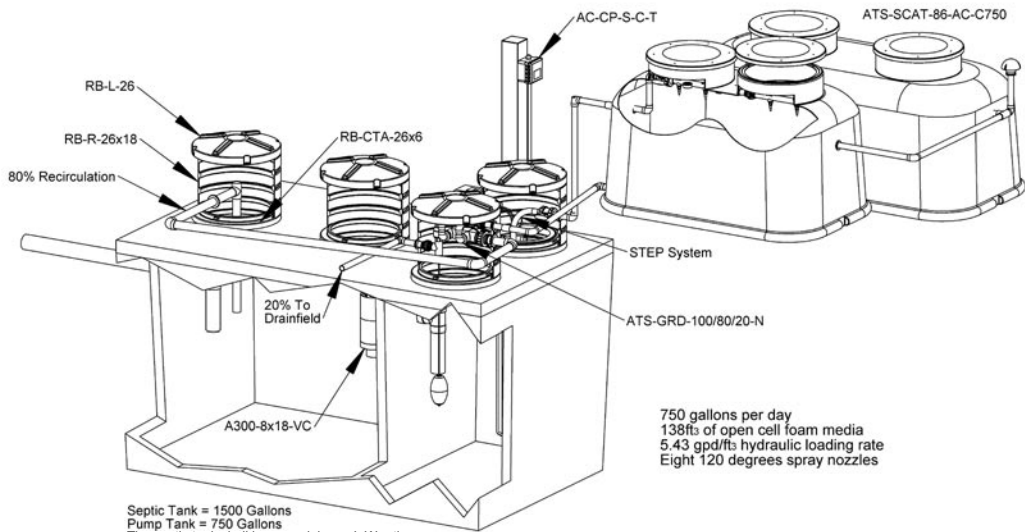

Septic Tank = 1500 Gallons  
 Pump Tank = 750 Gallons  
 The septic tank shall have a minimum L:W ratio of equal to or greater than one.

750 gallons per day  
 138ft of open cell foam media  
 5.43 gpd/fts hydraulic loading rate  
 Eight 120 degrees spray nozzles

**Parts Included:**

- ATS-SCAT-86-AC-C750
- A300-8x18-VC
- FPV-H44-4
- P-SE-13T
- PDS-ED-1.5
- PDS-GT-1.25
- PDS-GT-1.5 (2x)
- AC-FT-3
- AC-JSB-4
- AC-CP-S-C-T
- ATS-GRD-100/80/20-N
- RB-CTA-26x6 (4x)
- RB-R-26x18 (3x)
- RB-L-26 (3x)

Product(s) covered by one or more U.S. and/or International patents. Other U.S. and International patents may be pending.

DIMENSIONS ARE IN INCHES		NAME	DATE	<b>QUANICS Incorporated</b>	
TOLERANCES:		DRAWN	TNJ		08-08-05
FRACTIONAL ±		CHECKED	BB		08-08-05
ANGULAR: MACH ± BEND ±		ENG APPR.			
TWO PLACE DECIMAL ±		MFG APPR.			
THREE PLACE DECIMAL ±		G.A.			
MATERIAL		COMMENTS:			
NEXT ASSY	USED ON	FINISH	--		
APPLICATION	SCALE	1 : 35			

SIZE <b>A</b>	DWG. NO. <b>ATS-SCAT-86-AC-C750</b>	REV.
WEIGHT:		SHEET 1 OF 1

**1000 GPD AeroCell® System**  
[www.quanics.net/autocad.htm](http://www.quanics.net/autocad.htm)

ZONE		REV.		REVISIONS	DATE	APPROVED
				DESCRIPTION		

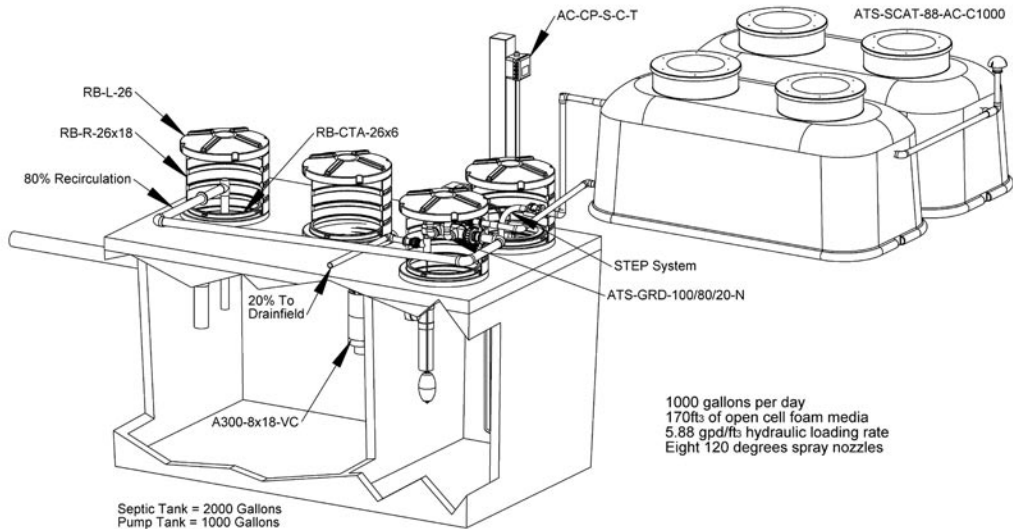

1000 gallons per day  
 170ft of open cell foam media  
 5.88 gpd/fts hydraulic loading rate  
 Eight 120 degrees spray nozzles

Septic Tank = 2000 Gallons  
 Pump Tank = 1000 Gallons  
 The septic tank shall have a minimum L:W ratio of equal to or greater than one.

**Parts Included:**

- ATS-SCAT-88-AC-C1000
- A300-8x18-VC
- FPV-H44-4
- P-SE-13T
- PDS-ED-1.5
- PDS-GT-1.25
- PDS-GT-1.5 (2x)
- AC-FT-3
- AC-JSB-4
- AC-CP-S-C-T
- ATS-GRD-100/80/20-N
- RB-CTA-26x6 (4x)
- RB-R-26x18 (3x)
- RB-L-26 (3x)

Product(s) covered by one or more U.S. and/or International patents. Other U.S. and International patents may be pending.

NEXT ASSY		USED ON	FINISH	SCALE	1 : 35	NAME	DATE	<b>QUANICS Incorporated</b> DRAWN: THJ 08-08-05 CHECKED: BB 08-08-05 ENG APPR: MFG APPR: I.O.A. COMMENTS:
			---					

SIZE	DWG. NO.	REV.
A	ATS-SCAT-88-AC-C1000	
WEIGHT:	SHEET 1 OF 1	

**1250 GPD AeroCell System**  
[www.quanics.net/autocad.htm](http://www.quanics.net/autocad.htm)

ZONE		REV.		REVISIONS	DATE	APPROVED
				DESCRIPTION		

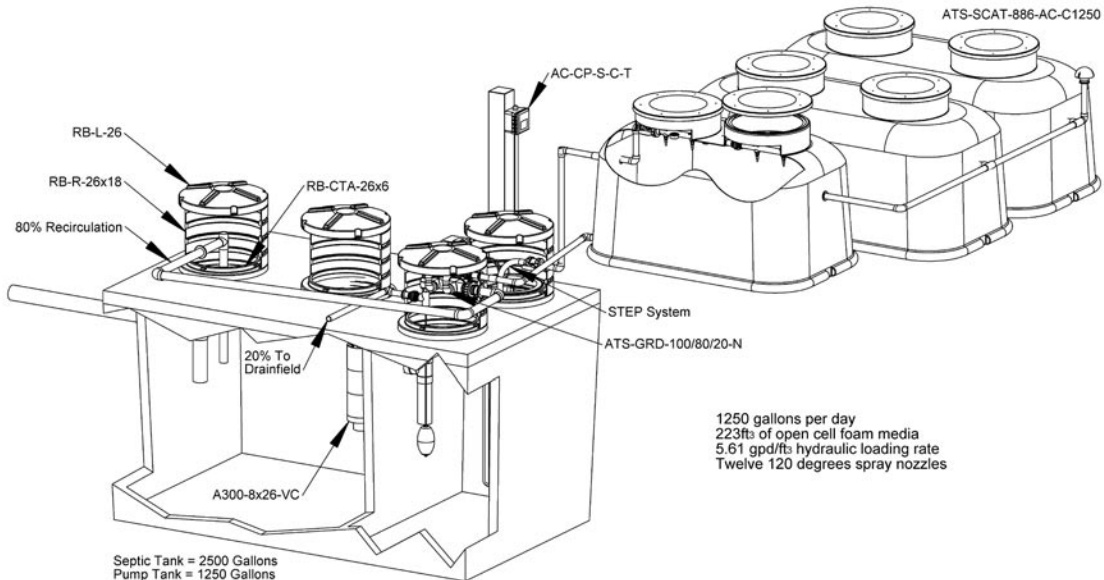

1250 gallons per day  
 223ft of open cell foam media  
 5.61 gpd/fts hydraulic loading rate  
 Twelve 120 degrees spray nozzles

Septic Tank = 2500 Gallons  
 Pump Tank = 1250 Gallons  
 The septic tank shall have a minimum L:W ratio of equal to or greater than one.

**Parts Included:**

- ATS-SCAT-886-AC-C1250
- A300-8x26-VC
- FPV-H44-4
- P-SE-13T
- PDS-ED-1.5
- PDS-GT-1.25
- PDS-GT-1.5 (2x)
- AC-FT-3
- AC-JSB-4
- AC-CP-S-C-T
- ATS-GRD-100/80/20-N
- RB-CTA-26x6 (4x)
- RB-R-26x18 (3x)
- RB-L-26 (3x)

Product(s) covered by one or more U.S. and/or International patents. Other U.S. and International patents may be pending.

NEXT ASSY		USED ON	FINISH	SCALE	1 : 35	NAME	DATE	<b>QUANICS Incorporated</b> DRAWN: THJ 08-08-05 CHECKED: BB 08-08-05 ENG APPR: MFG APPR: I.O.A. COMMENTS:
			---					

SIZE	DWG. NO.	REV.
A	ATS-SCAT-886-AC-C1250	
WEIGHT:	SHEET 1 OF 1	

# 1500 GPD AeroCell® System

www.quanics.net/autocad.htm

ZONE		REV.	REVISIONS	DATE	APPROVED
			DESCRIPTION		

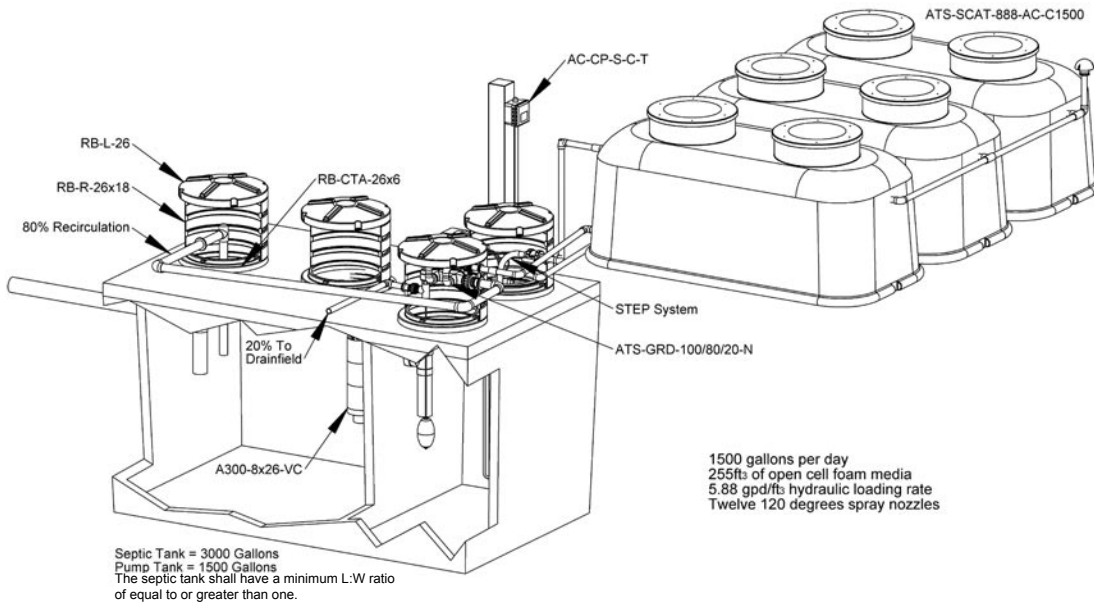

1500 gallons per day  
 255ft<sup>3</sup> of open cell foam media  
 5.88 gpd/ft<sup>3</sup> hydraulic loading rate  
 Twelve 120 degrees spray nozzles

Septic Tank = 3000 Gallons  
 Pump Tank = 1500 Gallons  
 The septic tank shall have a minimum L:W ratio of equal to or greater than one.

- Parts Included:
- ATS-SCAT-888-AC-C1500
  - A300-8x26-VC
  - FPV-H44-4
  - P-SE-13T
  - PDS-ED-1.5
  - PDS-GT-1.25
  - PDS-GT-1.5 (2x)
  - AC-FT-3
  - AC-JSB-4
  - AC-CP-S-C-T
  - ATS-GRD-100/80/20-N
  - RB-CTA-26x6 (4x)
  - RB-R-26x18 (3x)
  - RB-L-26 (3x)

Product(s) covered by one or more U.S. and/or International patents. Other U.S. and International patents may be pending.

		DIMENSIONS ARE IN INCHES		NAME		DATE		<b>QUANICS Incorporated</b>	
		TOLERANCES:		DRAWN		THJ			08-08-05
		FRACTIONAL ±		CHECKED		BB			08-08-05
		ANGULAR: MACH ± BEND ±		ENG APPR.					
		TWO PLACE DECIMAL ±		MFG APPR.					
		THREE PLACE DECIMAL ±		G.A.					
		MATERIAL		COMMENTS:					
NEXT ASSY	USED ON	FINISH	---	SIZE	DWG. NO.	REV.			
APPLICATION	SCALE	1 : 35		<b>A</b>	ATS-SCAT-888-AC-C1500				
						WEIGHT:	SHEET 1 OF 1		

# 500 GPD Bio-COIR System

www.quanics.net/autocad.htm

ZONE		REV.	REVISIONS	DATE	APPROVED
			DESCRIPTION		

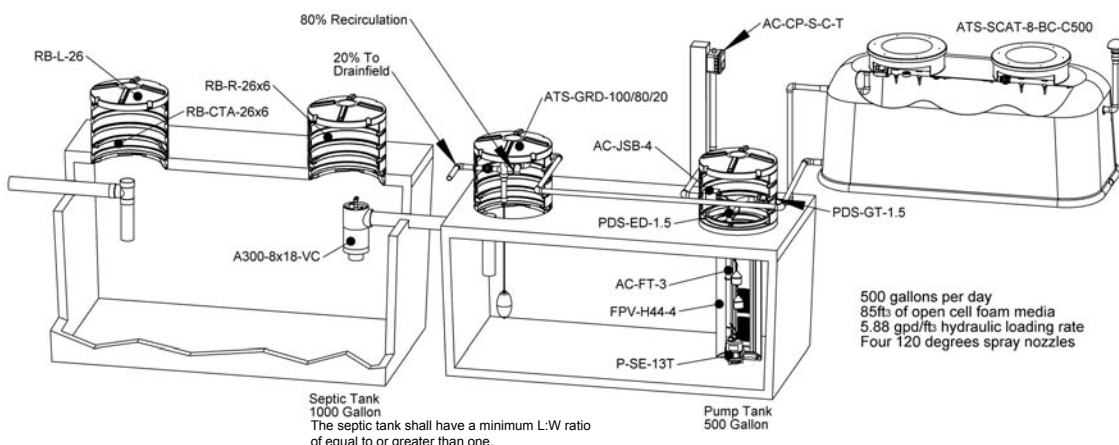

500 gallons per day  
 85ft<sup>3</sup> of open cell foam media  
 5.88 gpd/ft<sup>3</sup> hydraulic loading rate  
 Four 120 degrees spray nozzles

Septic Tank  
 1000 Gallon  
 The septic tank shall have a minimum L:W ratio of equal to or greater than one.

Pump Tank  
 500 Gallon

- Parts Included:
- ATS-SCAT-8-BC-C500
  - A300-8x18-VC
  - FPV-H44-4
  - P-SE-13T
  - PDS-ED-1.5
  - PDS-GT-1.5 (2x)
  - AC-FT-3
  - AC-JSB-4
  - AC-CP-S-C-T
  - ATS-GRD-100/80/20
  - RB-CTA-26x6 (4x)
  - RB-R-26x18 (3x)
  - RB-L-26 (3x)

Product(s) covered by one or more U.S. and/or International patents. Other U.S. and International patents may be pending.

		DIMENSIONS ARE IN INCHES		NAME		DATE		<b>QUANICS Incorporated</b>	
		TOLERANCES:		DRAWN		THJ			08-08-05
		FRACTIONAL ±		CHECKED		BB			08-08-05
		ANGULAR: MACH ± BEND ±		ENG APPR.					
		TWO PLACE DECIMAL ±		MFG APPR.					
		THREE PLACE DECIMAL ±		G.A.					
		MATERIAL		COMMENTS:					
NEXT ASSY	USED ON	FINISH	---	SIZE	DWG. NO.	REV.			
APPLICATION	SCALE	1 : 40		<b>A</b>	ATS-SCAT-8-BC-C500				
						WEIGHT:	SHEET 1 OF 1		

# 750 GPD Bio-COIR™ System

www.quanics.net/autocad.htm

REVISES		DATE	APPROVED
ZONE	REV.	DESCRIPTION	

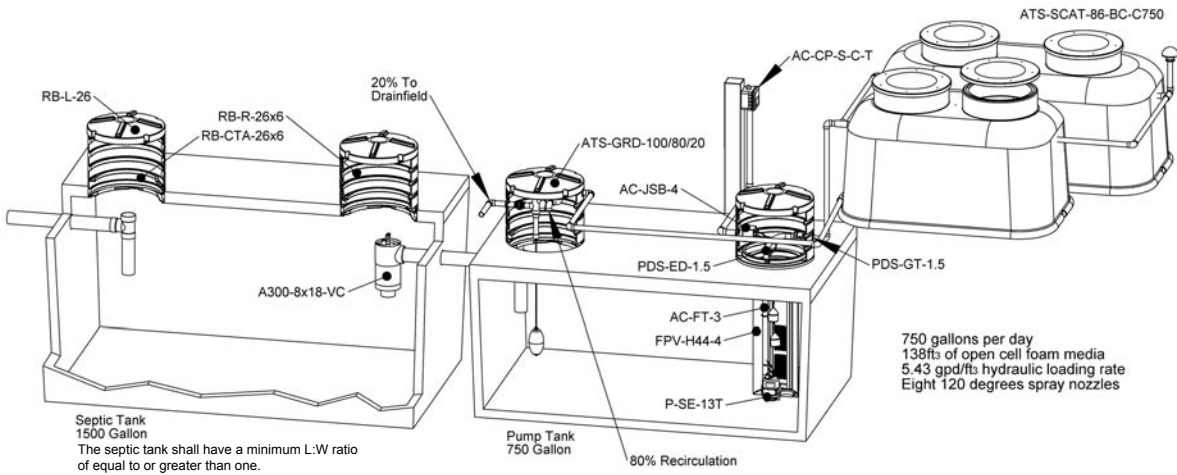

**Parts Included:**

- ATS-SCAT-86-BC-C750
- A300-8x18-VC
- FPV-H44-4
- P-SE-13T
- PDS-ED-1.5
- PDS-GT-1.5 (2x)
- AC-FT-3
- AC-JSB-4
- AC-CP-S-C-T
- ATS-GRD-100/80/20
- RB-CTA-26x6 (4x)
- RB-R-26x18 (3x)
- RB-L-26 (3x)

Product(s) covered by one or more U.S. and/or international patents. Other U.S. and international patents may be pending.

DIMENSIONS ARE IN INCHES		NAME	DATE	<b>QUANICS Incorporated</b>
TOLERANCES:		DRAWN	TNJ	
FRACTIONAL ±		CHECKED	BB	08-08-05
ANGULAR: MACH ±	BEND ±	ENG APPR.		
TWO PLACE DECIMAL ±		MFG APPR.		
THREE PLACE DECIMAL ±		G.A.		
MATERIAL		COMMENTS:		
NEXT ASSY	USED ON	FINISH	---	
APPLICATION		SCALE	1 : 40	
SIZE		DWG. NO.		REV.
A		ATS-SCAT-86-BC-C750		
WEIGHT:		SHEET 1 OF 1		

# 1000 GPD Bio-COIR System

www.quanics.net/autocad.htm

REVISES		DATE	APPROVED
ZONE	REV.	DESCRIPTION	

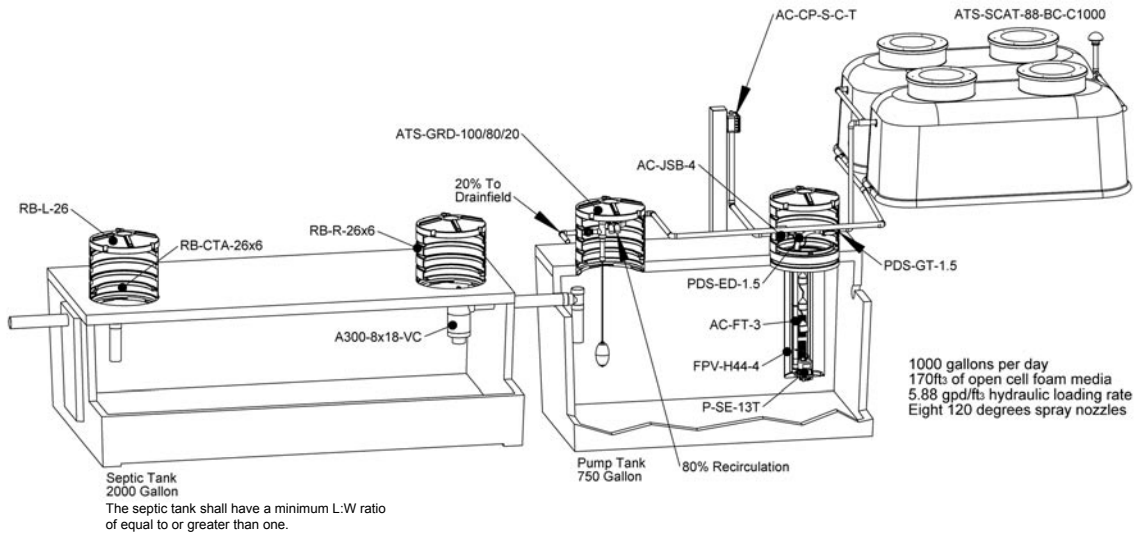

**Parts Included:**

- ATS-SCAT-88-BC-C1000
- A300-8x18-VC
- FPV-H44-4
- P-SE-13T
- PDS-ED-1.5
- PDS-GT-1.5 (2x)
- AC-FT-3
- AC-JSB-4
- AC-CP-S-C-T
- ATS-GRD-100/80/20
- RB-CTA-26x6 (4x)
- RB-R-26x18 (3x)
- RB-L-26 (3x)

Product(s) covered by one or more U.S. and/or international patents. Other U.S. and international patents may be pending.

DIMENSIONS ARE IN INCHES		NAME	DATE	<b>QUANICS Incorporated</b>
TOLERANCES:		DRAWN	TNJ	
FRACTIONAL ±		CHECKED	BB	08-08-05
ANGULAR: MACH ±	BEND ±	ENG APPR.		
TWO PLACE DECIMAL ±		MFG APPR.		
THREE PLACE DECIMAL ±		G.A.		
MATERIAL		COMMENTS:		
NEXT ASSY	USED ON	FINISH	---	
APPLICATION		SCALE	1 : 45	
SIZE		DWG. NO.		REV.
A		ATS-SCAT-88-BC-C1000		
WEIGHT:		SHEET 1 OF 1		

# 1250 GPD Bio-COIR™ System

www.quanics.net/autocad.htm

ZONE		REV.		REVISIONS		DATE		APPROVED	
ZONE	REV.	DESCRIPTION	DATE	APPROVED					

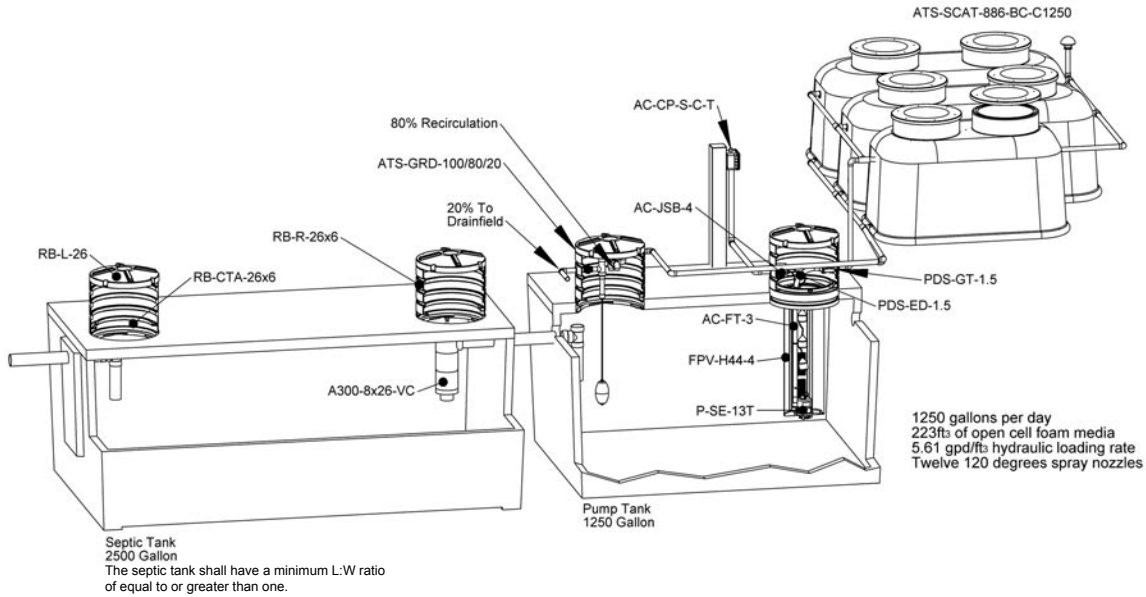

**Parts Included:**

- ATS-SCAT-886-BC-C1250
- A300-8x26-VC
- FPV-H44-4
- P-SE-13T
- PDS-ED-1.5
- PDS-GT-1.5 (2x)
- AC-FT-3
- AC-JSB-4
- AC-CP-S-C-T
- ATS-GRD-100/80/20
- RB-CTA-26x6 (4x)
- RB-R-26x6 (3x)
- RB-L-26 (3x)

Product(s) covered by one or more U.S. and/or International patents. Other U.S. and International patents may be pending.

DIMENSIONS ARE IN INCHES		NAME	DATE	<b>QUANICS Incorporated</b>	
TOLERANCES:		DRAWN	TNJ		08-08-05
FRACTIONAL ±		CHECKED	BB		08-08-05
ANGULAR: MACH ± BEND ±		ENG APPR.			
TWO PLACE DECIMAL ±		MFG APPR.			
THREE PLACE DECIMAL ±		Q.A.			
MATERIAL		COMMENTS:			
NEXT ASSY	USED ON	FINISH	---	SIZE DWG. NO.	
APPLICATION	SCALE	1 : 45		<b>A</b> ATS-SCAT-886-BC-C1250	
				REV.	
				WEIGHT:	
				SHEET 1 OF 1	

# 1500 GPD Bio-COIR System

www.quanics.net/autocad.htm

ZONE		REV.		REVISIONS		DATE		APPROVED	
ZONE	REV.	DESCRIPTION	DATE	APPROVED					

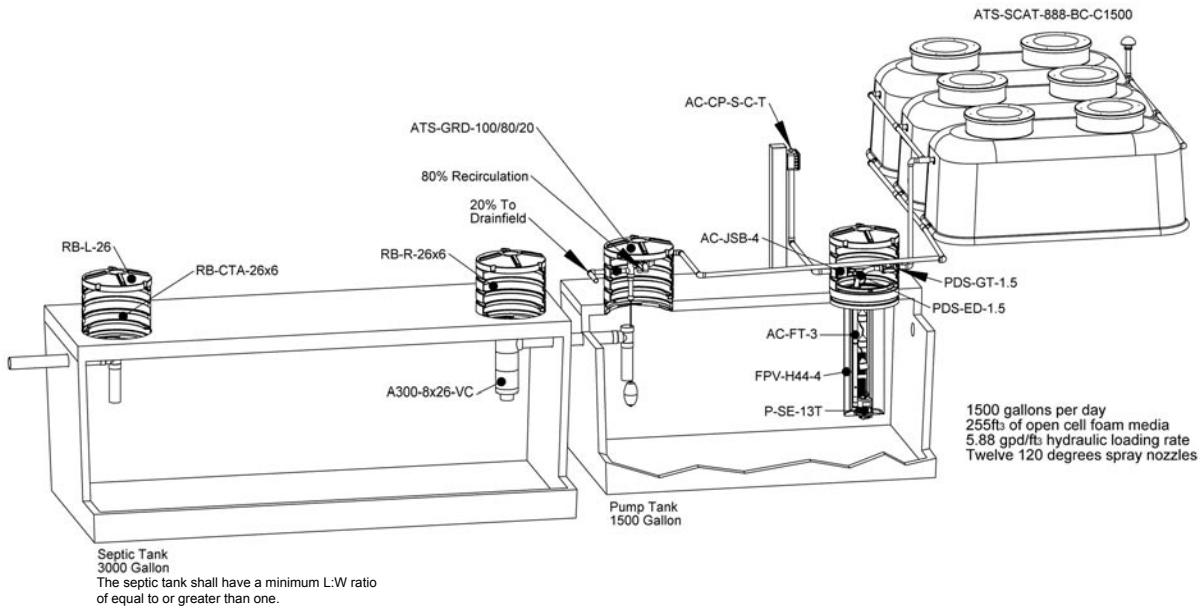

**Parts Included:**

- ATS-SCAT-888-BC-C1500
- A300-8x26-VC
- FPV-H44-4
- P-SE-13T
- PDS-ED-1.5
- PDS-GT-1.5 (2x)
- AC-FT-3
- AC-JSB-4
- AC-CP-S-C-T
- ATS-GRD-100/80/20
- RB-CTA-26x6 (4x)
- RB-R-26x6 (3x)
- RB-L-26 (3x)

Product(s) covered by one or more U.S. and/or International patents. Other U.S. and International patents may be pending.

DIMENSIONS ARE IN INCHES		NAME	DATE	<b>QUANICS Incorporated</b>	
TOLERANCES:		DRAWN	TNJ		08-08-05
FRACTIONAL ±		CHECKED	BB		08-08-05
ANGULAR: MACH ± BEND ±		ENG APPR.			
TWO PLACE DECIMAL ±		MFG APPR.			
THREE PLACE DECIMAL ±		Q.A.			
MATERIAL		COMMENTS:			
NEXT ASSY	USED ON	FINISH	---	SIZE DWG. NO.	
APPLICATION	SCALE	1 : 45		<b>A</b> ATS-SCAT-888-BC-C1500	
				REV.	
				WEIGHT:	
				SHEET 1 OF 1	

# ADVANCED TREATMENT SCAT® AeroCell® & Bio-COIR™

ATS-SCAT-6

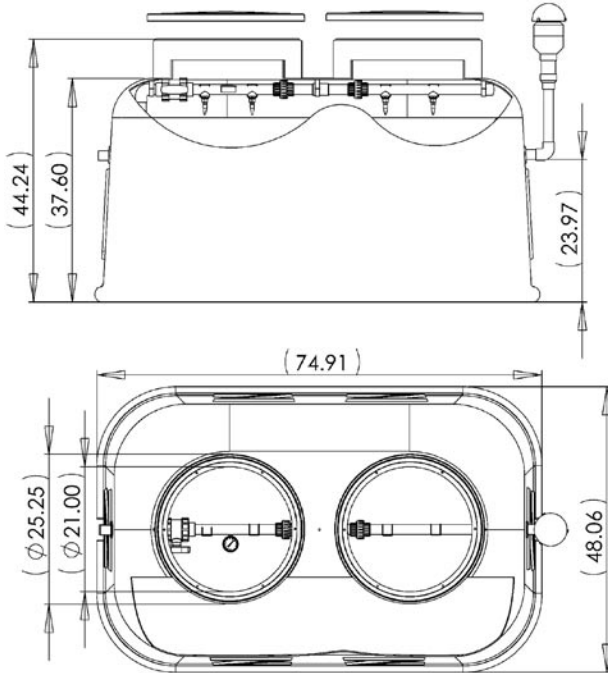

ATS-SCAT-8

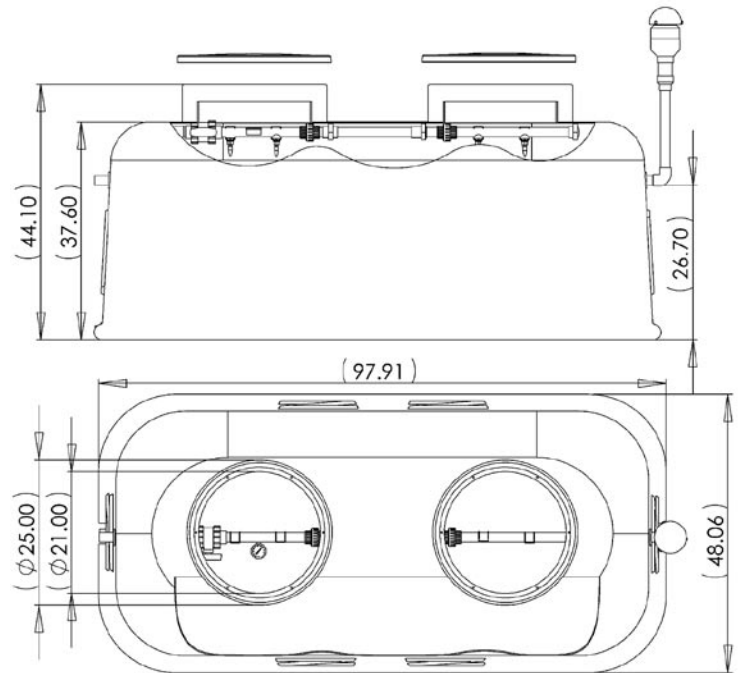

## AeroCell & Bio-COIR Specifications

Model #	GPD Rating	Nozzles	Modules	Media (ft <sup>3</sup> )	Loading (gpd/ft <sup>3</sup> )	Septic Tank (gal)	Pump Tank (gal)	Individual Dose Volume (gal)	Discharge Volume per Individual Dose (gal)	Doses per 24 hrs.
ATS-SCAT-8-AC-C500 ATS-SCAT-8-BC-C500	<b>500*</b>	4	1	85	5.88	1000	500	25.6	5.12	98
ATS-SCAT-86-AC-C750 ATS-SCAT-86-BC-C750	<b>750*</b>	8	2	138	5.43	1500	750	51.2	10.2	73
ATS-SCAT-88-AC-C1000 ATS-SCAT-88-BC-C1000	<b>1000*</b>	8	2	170	5.88	2000	1000	51.2	10.2	98
ATS-SCAT-886-AC-C1250 ATS-SCAT-886-BC-C1250	<b>1250*</b>	12	3	223	5.61	2500	1250	76.8	15.3	81
ATS-SCAT-888-AC-C1500 ATS-SCAT-888-BC-C1500	<b>1500*</b>	12	3	255	5.88	3000	1500	76.8	15.3	98

\* The Zabel® A300-8x18-VC model effluent filter is used in systems of 1200 gpd or less. The A300-8x26-VC filter is used in systems up to 1800 gpd. The septic tank shall have a minimum L:W ratio of equal to or greater than one.

## Features

- Effluent discharge and carbon filter vent assemblies included
- Fiberglass lid with neoprene gasket and security screws included
- Indented flat spots on bottom for easy grommet and outlet pipe installation.
- .015 - .016 lbs/ft<sup>3</sup>/day organic loading rate

## Warranty for Defects in Material and Workmanship

- Fiberglass SCAT Module - 2 years
- Effluent Discharge and Vent Assembly - 2 years

# EFFLUENT FILTER

## Filter Series (8")

A300-8x18-VC

A300-8x26-VC

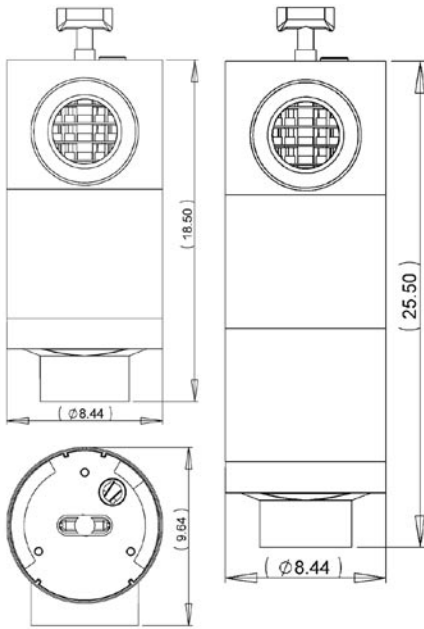

**A300-8x18-VC**

**GPD: 1200 / FS: 1/32"**

**A300-8x26-VC**

**GPD: 1800 / FS: 1/32"**

### Features

- Patented effluent filter for light commercial, grease traps and in conjunction with advanced treatment systems
- Average of 50% to 90% reduction in TSS within 6 months of installation
- Average of 20% to 45% reduction in BOD<sub>5</sub> within 6 months of installation, reduction is dependent on the make-up of the wastewater
- Average of 60% to 90% reduction in FOG within 6 months of installation
- Filter cartridges are green for easy identification
- Outlet hub accepts 4" or 6" SCH 40 outlet pipe
- All Zabel® Filters accept SmartFilter® alarm switch

**GPD = Maximum Gallons Per Day**

**FS = Filtration Size**

**Warranty for Defects in Material and Workmanship Effluent Filters - Limited Lifetime**

# FILTERED PUMP VAULT

## Hanging

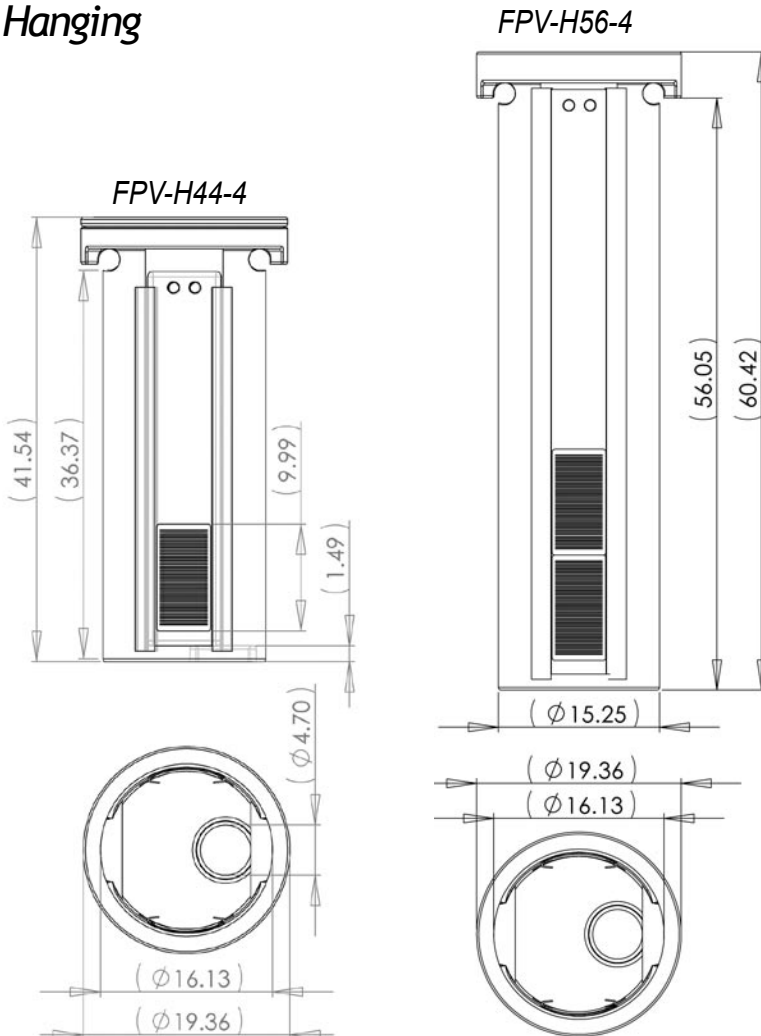

**FPV-H44-4, FPV-H56-4**

High density non-corrosive polyethylene plastic with stainless steel screws

### Features

- Hanging filtered pump vault installs into primary or pump tanks
- Protects pump and disposal field from solids larger than 1/16"
- Available with either 2 or 4 filter plates
- Includes maintenance plate for servicing ease

**Warranty for Defects in Material and Workmanship**

**FPVs - 2 Year**

**All FPVs when used with a QUANICS pump - 10 year**

# PRESSURE DISTRIBUTION Pumps

P-SE-13T

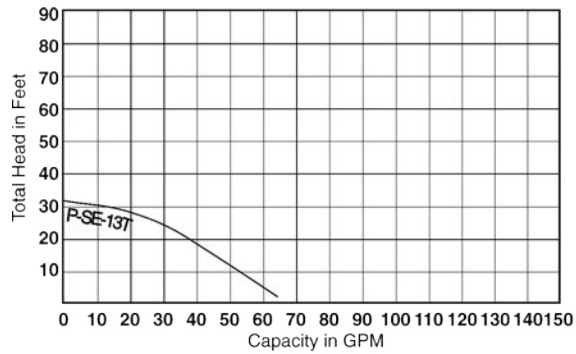
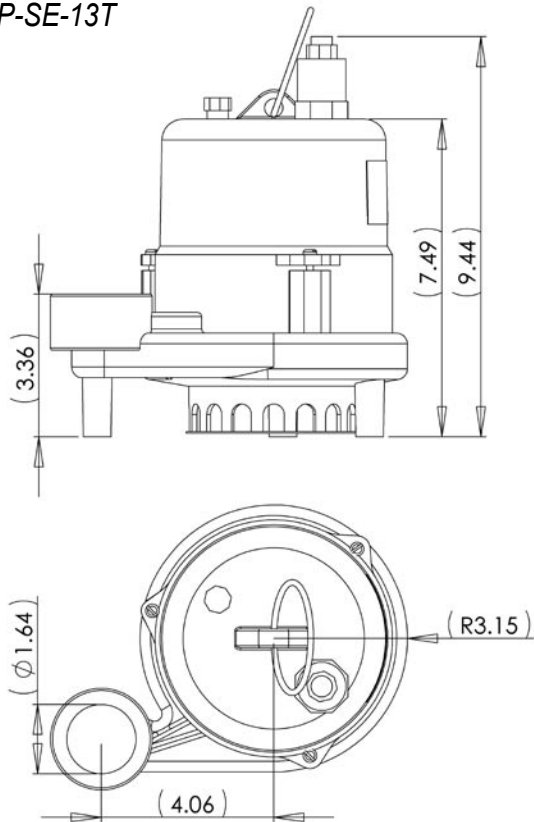

### Specifications

**Capacities:** From 15 - 80 GPM

**Heads:** To 260 FT

**Motor:** 1/2 HP; hermetically sealed with automatic thermal overload

**Electrical:** 115V, 12.0 FLA, 1PH, 60Hz

**Operation:** Manual model (controls required)  
Minimum Diameter: 4" (102mm)

**Impeller:** Delrin®, closed vane type

**Solids handling:** 1/8" (3.2mm)

**Power Cord:** 10' (3M), 300 V SJOW jacketed, 2-wire with ground

**Materials of Construction:** 300 grade stainless and cast-iron

**Discharge:** 1-1/2"

### Warranty for Defects in Material and Workmanship

- All components - 3 Years

# STEP SYSTEMS Effluent Discharges

PDS-ED-1.5

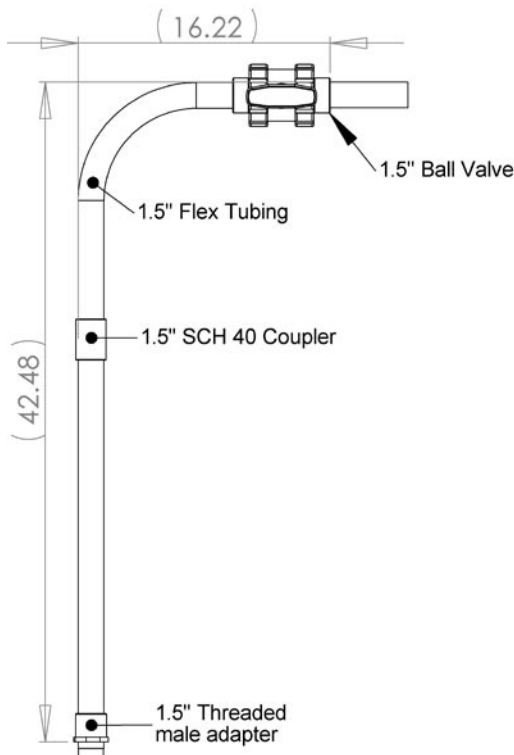

PDS-ED-2.0

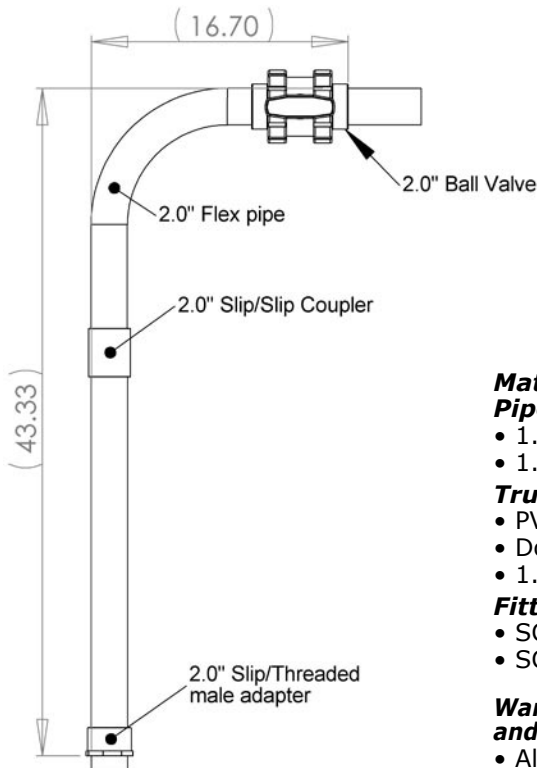

### Materials

#### Pipe

- 1.5" or 2" SCH 40 PVC
- 1.5" or 2" PVC flex tubing

#### True Union Ball Valve

- PVC Plastic
- Double block, full port design
- 1.5" or 2" slip/slip hubs

#### Fittings

- SCH 40 PVC threaded slip adapter
- SCH 40 PVC slip/slip adapter

### Warranty for Defects in Material and Workmanship

- All components - 2 Years



# Pressure Distribution Grommets

PDS-GT-1.5

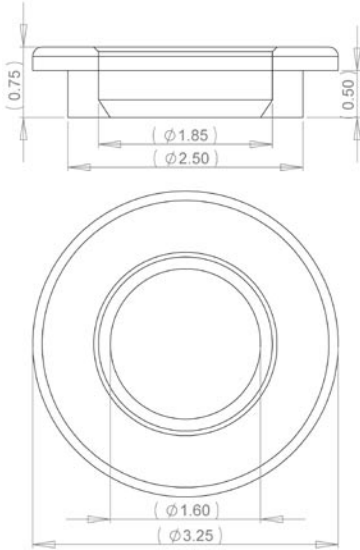

PDS-GT-2.0

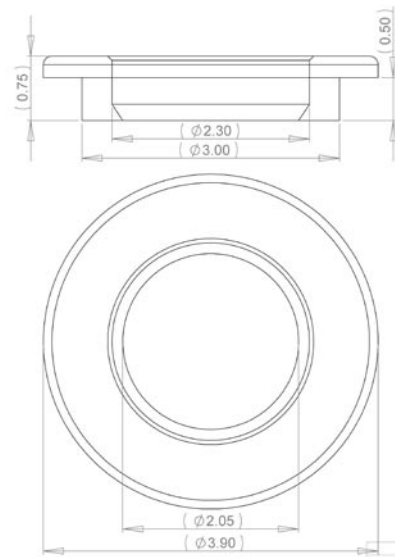

**Materials**

- 65 Durometer PVC

**Warranty for Defects in Material and Workmanship**

- All components - 2 Years

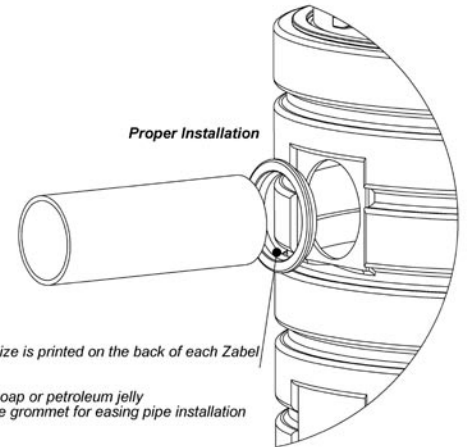

**Installation Tips:**

Proper hole saw size is printed on the back of each Zabel Grommet.

Put dishwashing soap or petroleum jelly on the inside of the grommet for easing pipe installation

# STEP SYSTEMS Float Tree

AC-FT-3

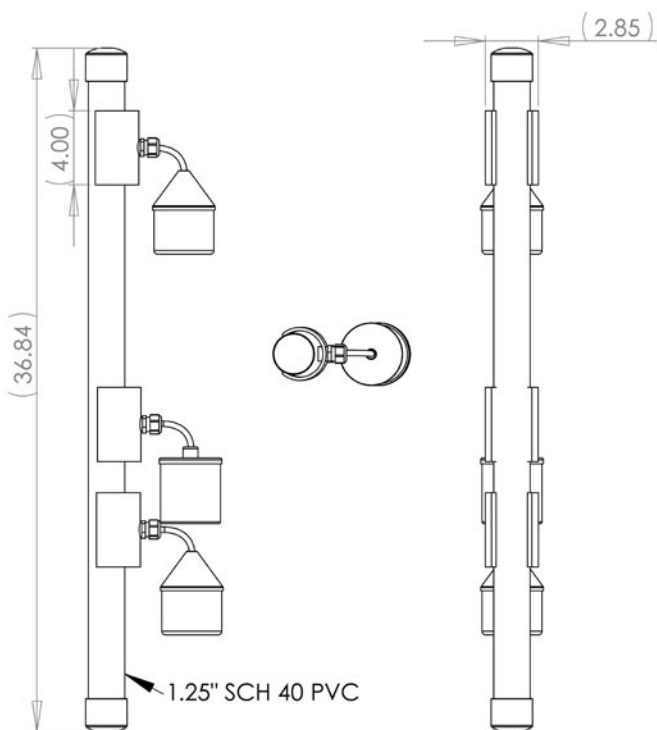

**Materials**

**Pipe**

- 1.5" or 2" SCH 40 PVC
- 1.5" or 2" PVC flex tubing

**True Union Ball Valve**

- PVC Plastic
- Double block, full port design
- 1.5" or 2" slip/slip hubs

**Fittings**

- SCH 40 PVC threaded slip adapter
- SCH 40 PVC slip/slip adapter

**Warranty for Defects in Material and Workmanship**

- All components - 2 Years

# STEP SYSTEMS

## Junction Box

AC-JSB-4

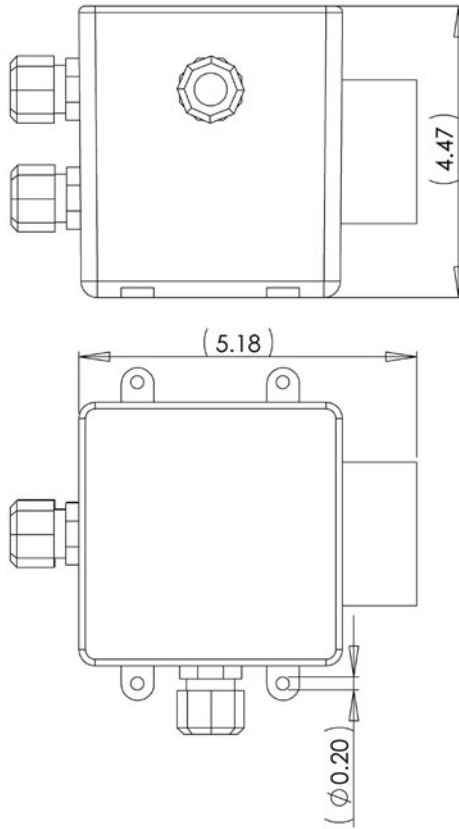

### Materials

#### Lid & Box

- High impact, corrosion resistant thermoplastic
- Weatherproof
- 1/2" UL approved, CSA Certified round cable liquid-tight strain relief connectors
- 1-1/2" terminal adapter hub

#### Gasket

- Flexible PVC

#### Screws

- Brass

### Warranty for Defects in Material and Workmanship

- Junction Boxes - 3 Years

# STEP SYSTEMS

## Control Panel

AC-CP-S-C-T

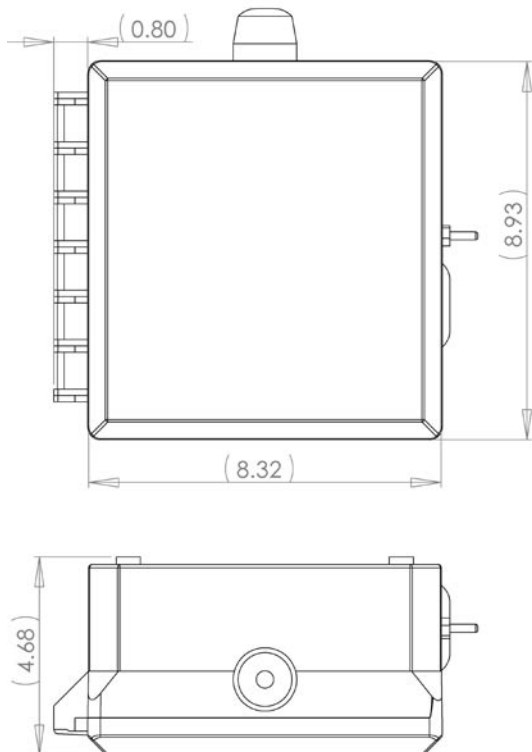

### Specifications

#### Enclosure

- Measures 10x8x4 inches (25.40x20.32x10.16 cm). NEMA 4X (ultraviolet stabilized thermoplastic with removable flanges for outdoor or indoor use).
- Magnetic Motor Contactor controls pump by switching hot electrical lines
- HOA Switch for manual pump control (mounted on circuit board)
- Float Switch Terminal Block
- Alarm and Control Fuses
- Programmable Timer with separate variable controls allows for setting the on and off times from .05 seconds to 30 hours.
- Circuit Breaker provides pump disconnect and branch circuit protection

#### Power Supply

- Pump-120/208/240V, 7-15FLA
- Alarm-120V

#### Standard Alarm Package

- Red Alarm Beacon provides 360 visual check of alarm condition
- Exterior Horn Test/Normal/Silence Switch allows alarm horn to be silenced and testing of horn and light to ensure proper operation of alarm system
- Horn Silence Relay automatically resets alarm after alarm condition has been resolved (mounted on circuit board)

### Warranty for Defects in Material and Workmanship

- Control Panel - 3 Years

# ADVANCED TREATMENT Recirculation Devices

ATS-GRD-100/80/20

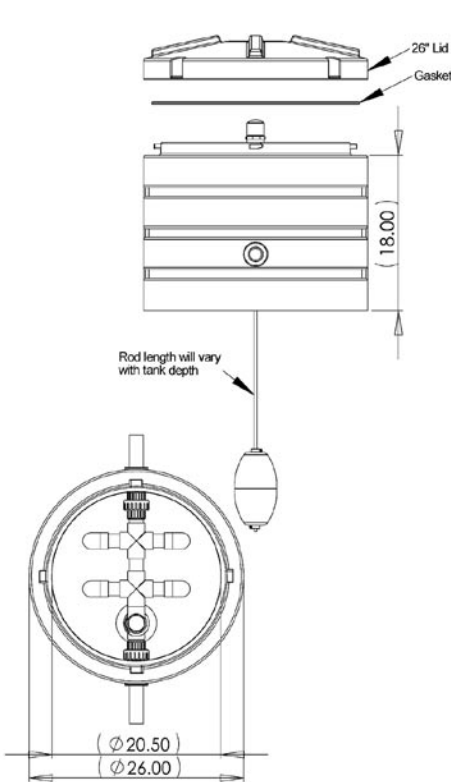

ATS-GRD-100/80/20-N

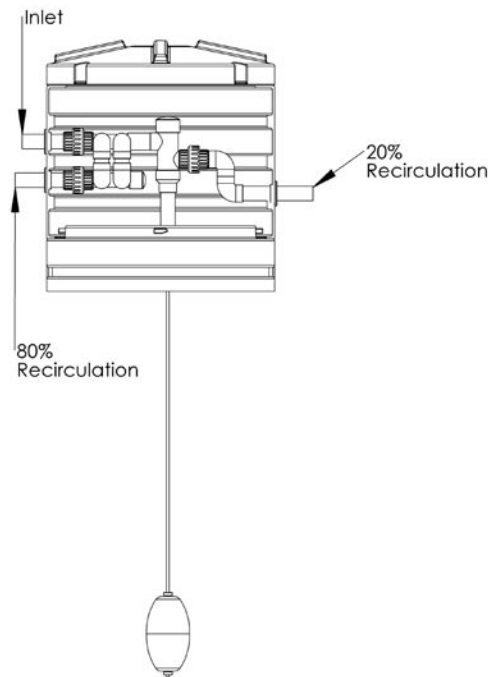

## Materials

### Riser and Lid

- High density non-corrosive polyethylene plastic
- Tested to withstand up to a 2500 lb wheel load
- Neoprene gasket
- Stainless steel tamper resistant hardware
- 26" diameter lid

### Effluent Discharge Assembly

- 1.25" Sch 40 PVC Pipe
- Rubber Grommets

### Float Valve Assembly

- 60" Stainless steel rod
- Polypropylene float

### Warranty for Defects in Material and Workmanship

- Riser and Lid - 2 Years
- Effluent Discharge Assembly - 2 Years
- Float Valve Assembly - 2 Years

## STEP SYSTEMS

### Risers, Lids, Tank Adapters

RB-RTA-26x2 (Retrofit Tank Adapter)

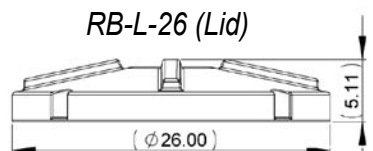
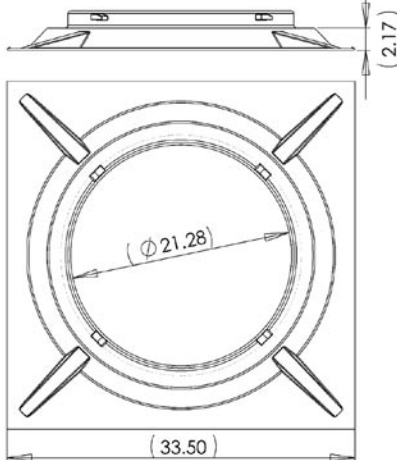

RB-CTA-26x6 (Cast-in Tank Adapter)



RB-R-26x18 (Riser)

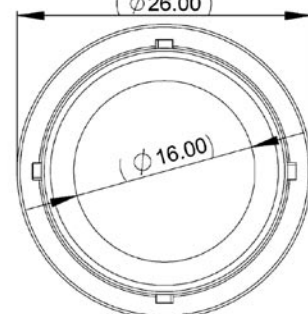
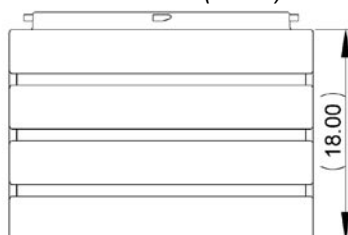

## Materials:

### Risers and Lids

- High density non-corrosive polyethylene plastic
- Stainless steel screws
- Neoprene gasket

### IMPORTANT:

- When adding risers together for deeper installations **QUANICS** does not recommend exceeding a maximum depth of 48".
- Neoprene gaskets must be installed as per instructions
- To prevent unauthorized entry install all tamper resistant fasteners as per instructions

### Warranty for Defects in Material and Workmanship

- Riser, Lids & Tank Adapters - 2 Years

# Wiring Schematics

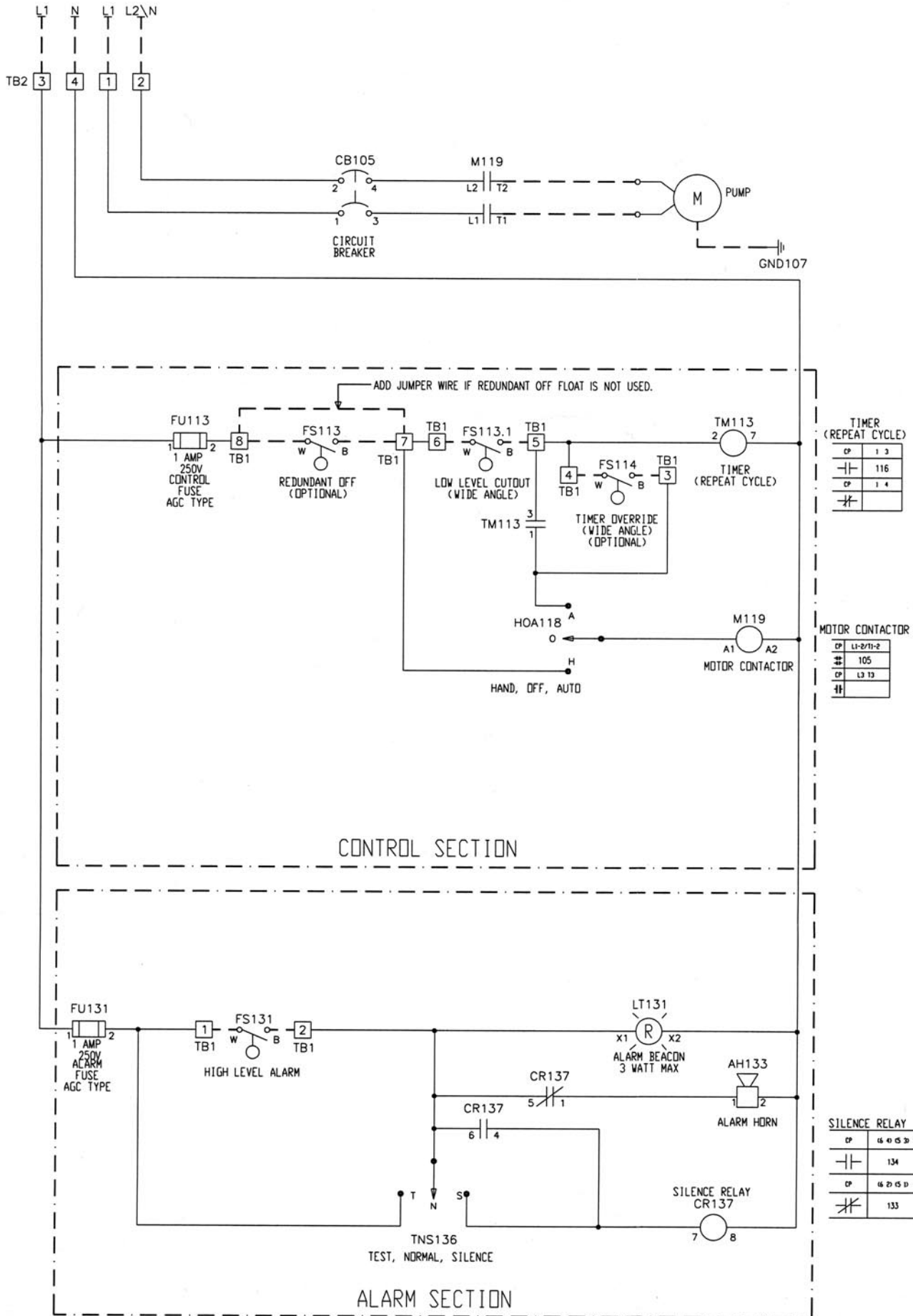

**TIMER (REPEAT CYCLE)**

CP	1 3
	116
CP	1 4

**MOTOR CONTACTOR**

CP	L1-2/T1-2
	105
CP	L3 13

**SILENCE RELAY**

CP	6 4 5 3
	134
CP	6 2 5 1
	133

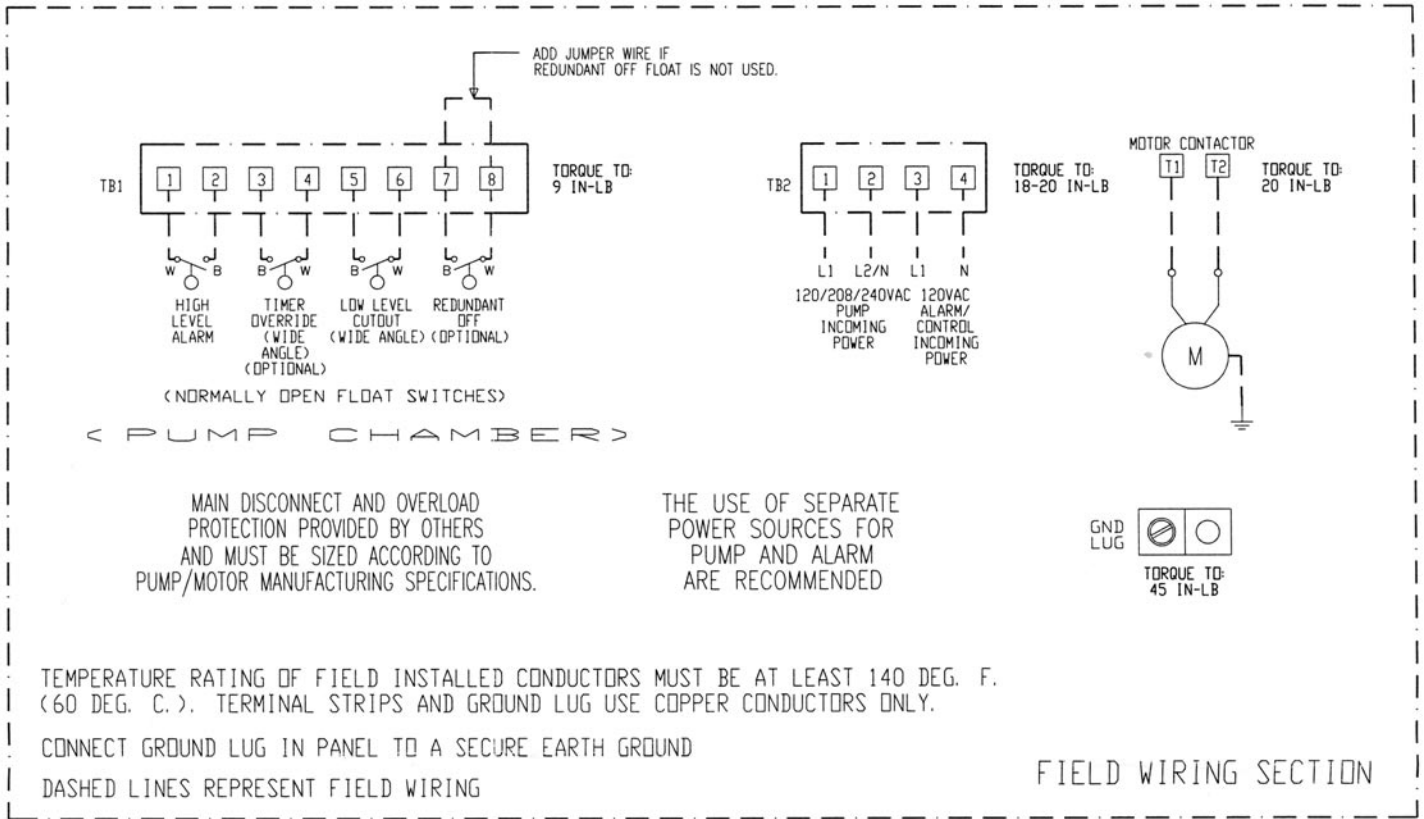

## Consecutively Serial Numbered Data Plates & Maintenance Sticker



## **Notes**

## **Notes**



P.O. BOX 1520  
6244 OLD LAGRANGE ROAD  
CRESTWOOD, KY 40014  
[www.quanics.net](http://www.quanics.net)

PHONE: (502) 992-8200  
1-877-QUANICS  
FAX: (502) 992-8201

Treatment system service provider: