

MYERS® ME SERIES

The Myers ME series effluent pumps are designed specifically for effluent pressure distribution mounds, trenches and high-flow drainage applications. Heavy-duty construction with finest corrosion-resistant materials for years of extended service in the harshest environments. Available in single- and double-seal models; thermoplastic and bronze impeller models.

APPLICATIONS

Effluent removal, sump drainage, water transfer, flood control

SPECIFICATIONS

Capacities – Up to 120 GPM (454 LPM)
Shut-off Head – Up to 95' (28.9 m)
Max. Spherical Solids – 3/4" (19 mm)
Liquids Handling – Domestic effluent and drain water
Intermittent Liquid Temperature – Up to 140°F (60°C)
Motor/Electrical Data – 1/2 HP, 115V, 1Ø; 1/2 to 1-1/2 HP, 230V, 1Ø; 208/230/460/575V, 3Ø; oil-filled, permanent split capacitor type, 1Ø, 3450 RPM, 60Hz
Acceptable pH Range – 6-9
Specific Gravity – .9-1.1
Viscosity – 28-35 SSU
Discharge, NPT – 2" (50.8 mm)
Housing – Cast iron
Volute Case – Cast iron
Impeller – Thermoplastic, or bronze (optional)
Minimum Sump Diameter – Simplex: 24" (61.0 cm)
 Duplex: 36" (91.4 cm)
Power Cord – 20'



FEATURES

Cast Iron Tough

All cast-iron housing and volute case resists the most extreme corrosive environments

High-efficiency Dosing

Engineered thermoplastic or bronze (optional) two-vane impeller provides ideal performance for efficient dosing

Jam-proof

Enclosed impeller design eliminates jamming between impeller and volute

Powerful Torque

High-torque, permanent split capacitor (PSC) motor; no starting switches or relays to wear out

Runs Cooler

Rugged, oil-filled motor for bearing lubrication and maximum heat dissipation

Leak Protection

Optional leak probe senses water leakage past seal (dual seal motors only)

Thermal Protection

Heat sensor overload protection with automatic reset when motor cools to a safe operating temperature (single phase only)

MYERS® ME SERIES

ORDERING INFORMATION

Catalog Number	HP	Volts	Phase/ Cycles	Discharge Size	Switch Type	Approx. Cord Length	Wt. Lbs.
SINGLE SEAL							
ME50S-11	1/2	115	1/60	2"	Manual	20'	73
ME50S-01	1/2	200	1/60	2"	Manual	20'	73
ME50S-21	1/2	230	1/60	2"	Manual	20'	74
ME50S-03	1/2	200	3/60	2"	Manual	20'	74
ME50S-23	1/2	230	3/60	2"	Manual	20'	74
ME50S-43	1/2	460	3/60	2"	Manual	20'	74
ME50S-53	1/2	575	3/60	2"	Manual	20'	74
ME75S-01	3/4	200	1/60	2"	Manual	20'	81
ME75S-21	3/4	230	1/60	2"	Manual	20'	81
ME75S-03	3/4	200	3/60	2"	Manual	20'	81
ME75S-23	3/4	230	3/60	2"	Manual	20'	81
ME75S-43	3/4	460	3/60	2"	Manual	20'	81
ME75S-53	3/4	575	3/60	2"	Manual	20'	81
ME100S-01	1	200	1/60	2"	Manual	20'	83
ME100S-21	1	230	1/60	2"	Manual	20'	83
ME100S-03	1	200	3/60	2"	Manual	20'	83
ME100S-23	1	230	3/60	2"	Manual	20'	83
ME100S-43	1	460	3/60	2"	Manual	20'	83
ME100S-53	1	575	3/60	2"	Manual	20'	83
ME150S-01	1-1/2	200	1/60	2"	Manual	20'	84
ME150S-21	1-1/2	230	1/60	2"	Manual	20'	84
ME150S-03	1-1/2	200	3/60	2"	Manual	20'	85
ME150S-23	1-1/2	230	3/60	2"	Manual	20'	85
ME150S-43	1-1/2	460	3/60	2"	Manual	20'	85
ME150S-53	1-1/2	575	3/60	2"	Manual	20'	85
DOUBLE SEAL							
ME50D-11	1/2	115	1/60	2"	Manual	20'	88
ME50D-01	1/2	200	1/60	2"	Manual	20'	88
ME50D-21	1/2	230	1/60	2"	Manual	20'	88
ME50D-03	1/2	200	3/60	2"	Manual	20'	88
ME50D-23	1/2	230	3/60	2"	Manual	20'	88
ME50D-43	1/2	460	3/60	2"	Manual	20'	88
ME50D-53	1/2	575	3/60	2"	Manual	20'	88
ME75D-01	3/4	200	1/60	2"	Manual	20'	95
ME75D-21	3/4	230	1/60	2"	Manual	20'	95
ME75D-03	3/4	200	3/60	2"	Manual	20'	95
ME75D-23	3/4	230	3/60	2"	Manual	20'	95
ME75D-43	3/4	460	3/60	2"	Manual	20'	95
ME75D-53	3/4	575	3/60	2"	Manual	20'	95
ME100D-01	1	200	1/60	2"	Manual	20'	97
ME100D-21	1	230	1/60	2"	Manual	20'	97
ME100D-03	1	200	3/60	2"	Manual	20'	97
ME100D-23	1	230	3/60	2"	Manual	20'	97
ME100D-43	1	460	3/60	2"	Manual	20'	97
ME100D-53	1	575	3/60	2"	Manual	20'	97
ME150D-01	1-1/2	200	1/60	2"	Manual	20'	98
ME150D-21	1-1/2	230	1/60	2"	Manual	20'	98
ME150D-03	1-1/2	200	3/60	2"	Manual	20'	98
ME150D-23	1-1/2	230	3/60	2"	Manual	20'	98
ME150D-43	1-1/2	460	3/60	2"	Manual	20'	98
ME150D-53	1-1/2	575	3/60	2"	Manual	20'	98

MYERS® ME SERIES

DIMENSIONS

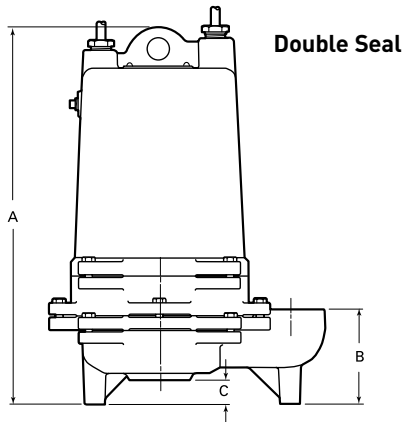
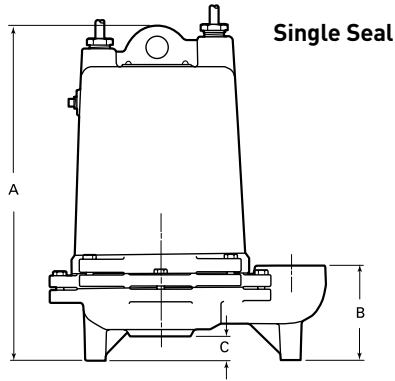
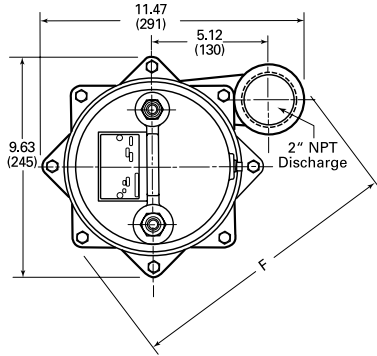

PUMP PERFORMANCE

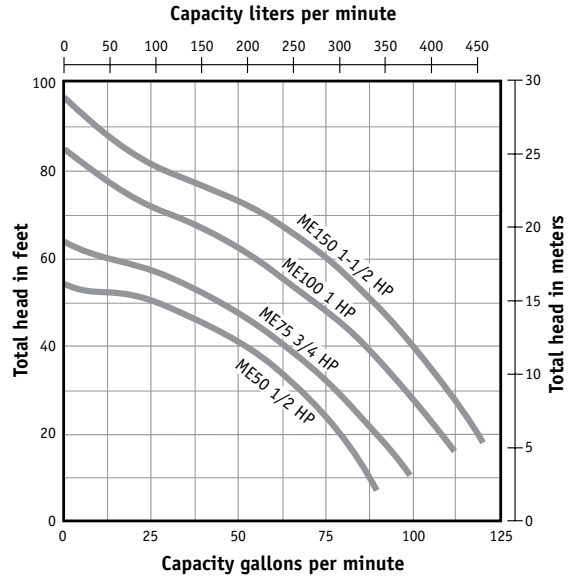

Catalog Number	Inches (millimeters)			
	A	B	C	F
ME50S	16.8 (427)	4.09 (104)	1.03 (26)	12.13 (308)
ME50D	18.6 (472)	4.09 (104)	1.03 (26)	12.13 (308)
ME75S, ME100S, ME150S	16.8 (427)	4.0 (102)	1.06 (27)	12.5 (318)
ME75D, ME100D, ME150D	18.6 (472)	4.0 (102)	1.06 (27)	12.5 (318)

MYERS® ME SERIES

SPECIFICATIONS

Effluent Pumps – Pump(s) shall be F. E. Myers ME series double seal effluent pumps selected in accordance with the following design criteria:

Number of Pumps:	_____	Motor Horsepower:	_____
Primary Design Flow:	_____	Motor Speed:	3450 RPM
Primary Design Head:	_____	Electrical:	_____
Minimum Shut-off Head:	_____		

Pump – The pump shall be designed to handle septic tank effluent and be capable of passing 3/4 inch spherical solids. The pump shall be capable of handling liquids with temperatures to 140°F intermittent and shall be capable of running dry without damage to the seals or bearings.

Motor – The pump motor shall be of the submersible type rated 1/2, 3/4, 1, or 1-1/2 hp as required. Motor shall operate at 3450 RPM and shall be for 115 volts (1/2 hp) or 230 volts single phase, or 200, 230, 460, or 575 volts, 3 phase, 60 cycles. Single phase motors shall be of the permanent split capacitor type with no relays or starting switches. Three phase motors shall be squirrel cage induction type. Stator winding shall be of the open type with Class B insulation rated for 130°C maximum operating temperature. The winding housing will be filled with clean dielectric oil to lubricate bearings, seals, and transfer heat from the windings to the outer shell. The motor assembly shall be of the standard frame design and shall be secured in place by four threaded fasteners allowing for easy field serviceability.

The motor shall be capable of operating over the full range of the performance curve without overloading the motor and causing any objectionable noise or vibration. The common motor pump shaft shall be of 416 stainless steel and shall be heat shrunk into the die cast motor rotor. The motor shall have two bearings to support the rotor; an upper ball bearing to accommodate radial loads and a lower ball bearing to take thrust and radial loads. Ball bearings shall be designed for a B-10 life of 50,000 hours.

A heat sensor thermostat and overload shall be attached to the top end of the motor windings and shall be wired in series with the windings to stop the motor if the motor winding temperature reaches 266°F. The overload thermostat shall reset automatically when the motor cools to a safe operating temperature. Three phase motors shall be protected by 3 leg overload relay in control box. Overload shall be of the quick trip ambient compensated type and shall have manual reset button.

Power Cord – The motor power cord shall be SJOW or SOOW. The cable jacket shall be sealed at the motor entrance by means of a rubber compression washer and compression nut. A heat shrink tube filled with epoxy shall seal the outer cable jacket and the individual leads to prevent water from entering the motor housing.

Shaft Seal (Single Seal) – The motor shall be protected by a rotating mechanical shaft seal. The seal shall have carbon and ceramic seal faces lapped to a tolerance of one light band. Metal parts and springs for seals shall be 300 series stainless steel.

Shaft Seal (Double Seal) – The motor shall be protected by two (2) rotating mechanical shaft seals mounted in tandem with an oil filled chamber separating the seals. The seals shall have carbon and ceramic seal faces lapped to a tolerance of one light band. Metal parts and springs for seals shall be 300 series stainless steel. Two electrical sensing probes shall be mounted in the seal chamber to detect any water leakage past the lower seal. The sensing probes shall be connected to a red warning light in the control panel. The warning light shall serve to indicate a seal leak condition and shall not stop the pump.

Pump Impeller – The pump impeller shall be of the two vane enclosed type. The impeller shall be constructed of engineered thermoplastic or optional bronze. A stainless steel wear ring shall be molded into the neck of the plastic impeller to provide a sealing surface. A replaceable Buna-N sealing cup shall effect a seal between the volute and impeller in order to maintain high efficiency and prevent recirculation. The impeller shall be threaded onto the 416 stainless steel pump/motor shaft.

Pump and Motor Castings – All castings shall be of high tensile strength Class 30 gray cast iron. Castings shall be treated with phosphate and chromate rinse and painted with a high quality air dry alkyd enamel.

Fasteners – All exposed fasteners shall be of 300 series stainless steel.



USA
293 WRIGHT STREET, DELAVAN, WI 53115 WWW.FEMYERS.COM
PH: 888-987-8677 ORDERS FAX: 800-426-9446

CANADA
490 PINEBUSH ROAD, UNIT 4, CAMBRIDGE, ONTARIO N1T 0A5
PH: 800-363-7867 ORDERS FAX: 888-606-5484

Because we are continuously improving our products and services, Pentair reserves the right to change specifications without prior notice.