

Pressure Filters

**PDS-PF-1.5/2.0, PDS-PF-1.5-AP,
PDS-PF-2.0-AP**

Models include:

PDS-PF-1.5/2.0

- Pressure filter body
- Screen element cartridge
- Pressure gauge
- Clear basin
- Stainless steel safety eye
- Drain port/cap
- 1-1/2" x 2" SCH 40 slip/slip bushings (2x)

PDS-PF-1.5-AP, PDS-PF-2.0-AP (Assembly Package)

- Pressure filter body
- Screen filter cartridge
- Pressure gauge
- Clear basin
- Drain port/cap
- All plumbing parts (as seen at top right)

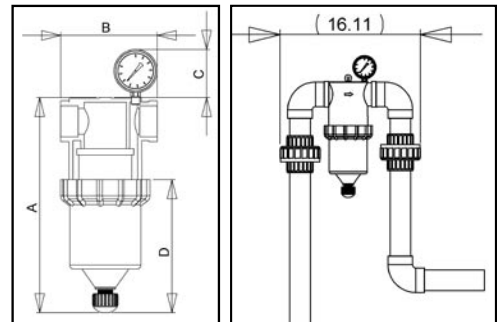
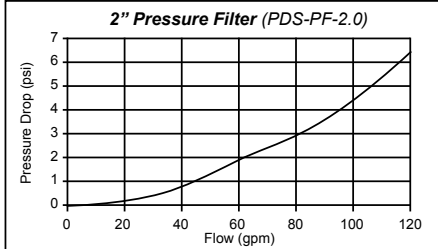
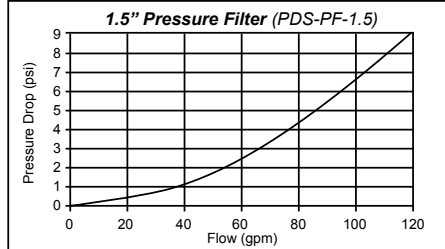
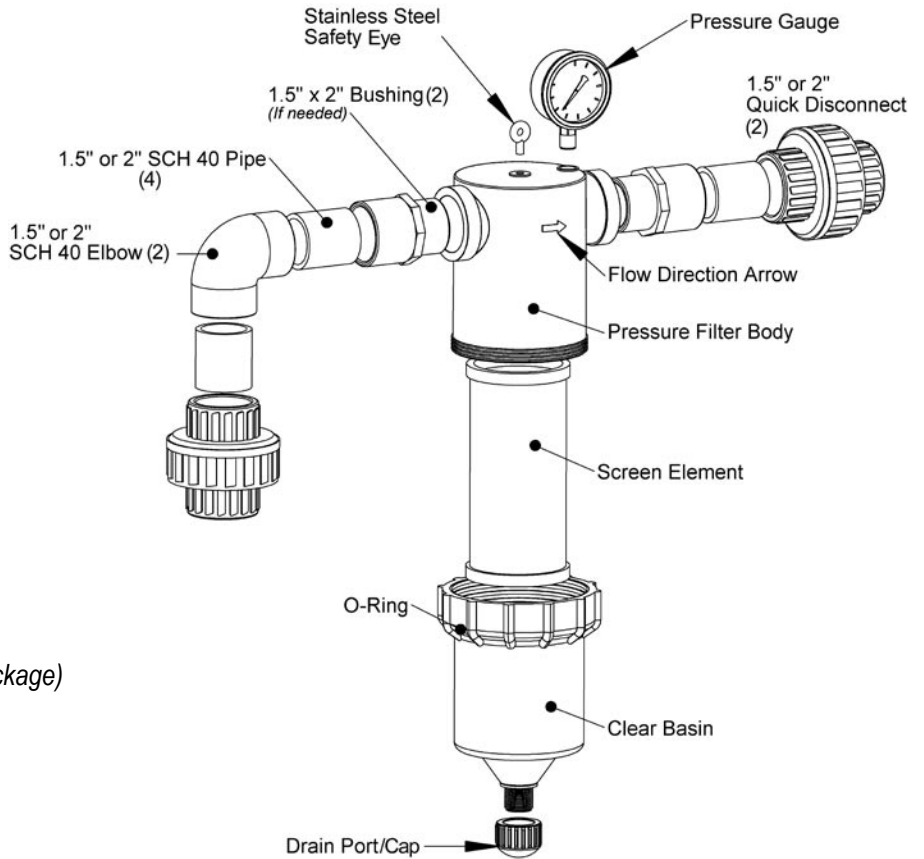

PDS-PF-1.5, PDS-PF-2.0				
Dimensions	A	B	C	D
Inches:	13.28	5.93	2.96	8.21
Materials:				
Upper Body:	Black UV Stabilized, PVC			
Clear Basin:	Polycarbonate			
Screen:	Stainless Steel			
Gasket:	EPDM (Standard)			
Max Flow:	120 gallons per minute (GPM)			

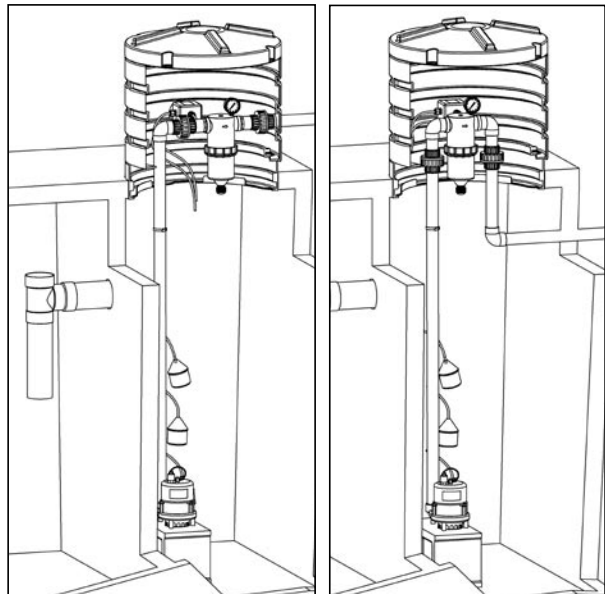

Warranty for Defects in Material and Workmanship

- 1 Year

AutoCad dwg files at www.quanics.net

1-877-QUANICS - www.quanics.net



© 2007, Quanics Inc. All rights reserved. Product(s) covered by one or more U.S. and/or International patents. Other U.S. and International patents may be pending.

