

**BDN FASTENERS**

**AS3566  
Building Fasteners**

**Made in Taiwan**





## ABOUT

- ◆ 3D Screw Modeling for Drawing Verification and Presentation
- ◆ Constant New Product Development
- ◆ Quality Guaranteed
- ◆ On-Time Delivery
- ◆ Competitive Pricing
- ◆ Efficient Customer Service
- ◆ Unique and Expressive Packaging Design



**2009**

Established in 2009 and began the trade of selling construction fasteners.



**2014**

BDN FASTENERS, the 100% made in Taiwan brand, steps into the fasteners scene.



**2015**

BDN FASTENERS Thailand was established in 2015, and set up as a base for sales and promotion of BDN Fasteners in ASEAN countries.



**2017**

BDN Fasteners takes a major step forward and builds a new facility dedicated to Heading, Threading, and Pinch Pointing processes - maximizing speed and efficiency, taking our service and quality to the next level.



**2018**

Despite hard times, BDN Fasteners takes yet another bold step forwards, relocating to a larger storage and packaging facility for better logistics, accommodate additional personnel, and new packaging machinery.



# CONTENTS

## METAL-Tite

---

VALLEY FIXING FASTENERS



01

CREST FIXING FASTENERS



02

STITCHING FASTENERS



03

CONCEALED FIXING FASTENERS



04

## TIMBER-Tite

---

VALLEY FIXING FASTENERS



05

CREST FIXING FASTENERS



06

## POLYXPAND

---

SKYLIGHT FIXING FASTENERS

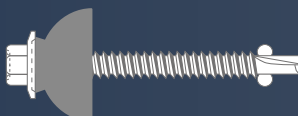

07

## VALLEY FIXING FASTENERS

Carbon steel fasteners for fixing steel sheets into steel substrates

### STEEL PENETRATION

Max 6.0mm thick (For #12 gauge)

### ADAPTER TO USE

Magnetic Hex Socket (5/16" )

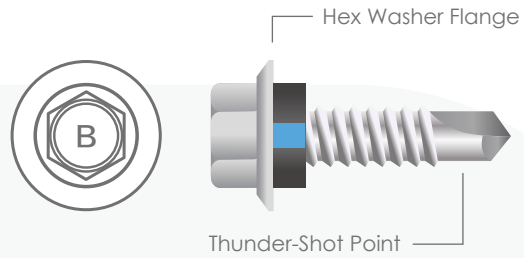
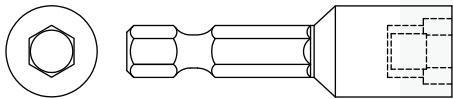

### PRODUCT FEATURES

Hex Washer Flange

Thunder-Shot Point

### WASHER

True Blue DEKS Blue Seal Washer

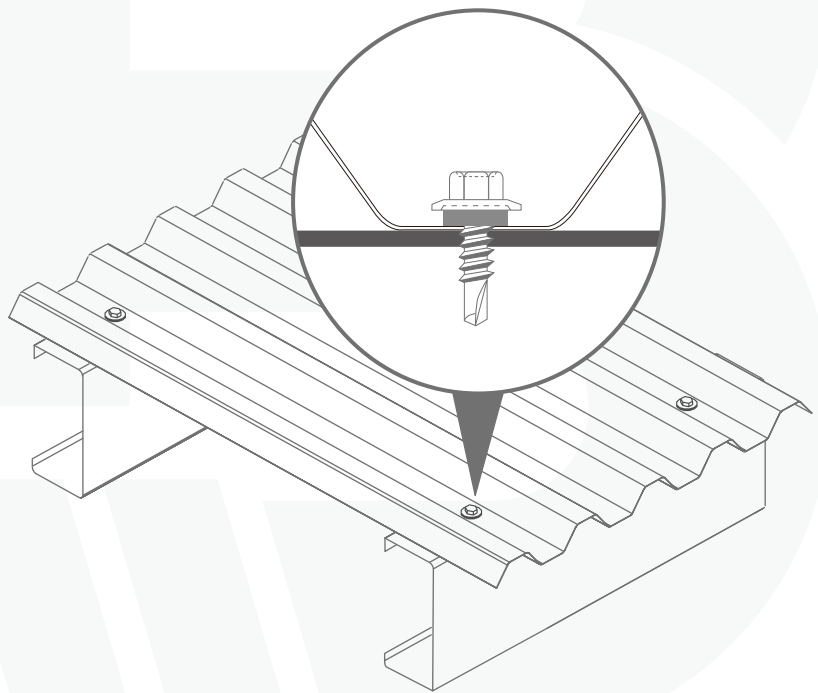

### PART NUMBER

#### Silver

BS-SDHC1225C3N 12-14 x 25mm

BS-SDHC1235C3N 12-14 x 35mm

## CREST FIXING FASTENERS

Carbon steel fasteners for fixing steel sheets into steel substrates

### STEEL PENETRATION

Max 6.0mm thick (For #12 gauge)

### ADAPTER TO USE

Magnetic Hex Socket (5/16" )

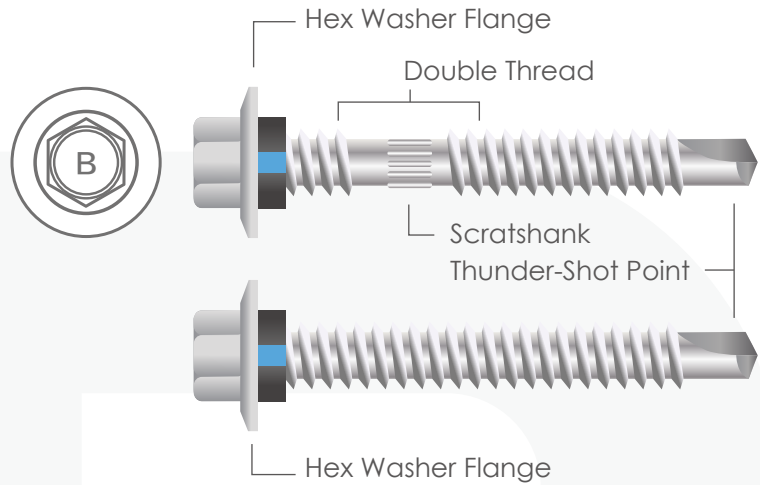
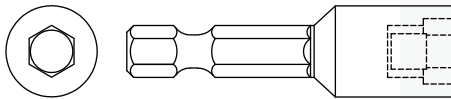

### PRODUCT FEATURES

Hex Washer Flange  
Thunder-Shot Point  
Double Thread  
Scratchank

### WASHER

True Blue DEKS Blue Seal Washer

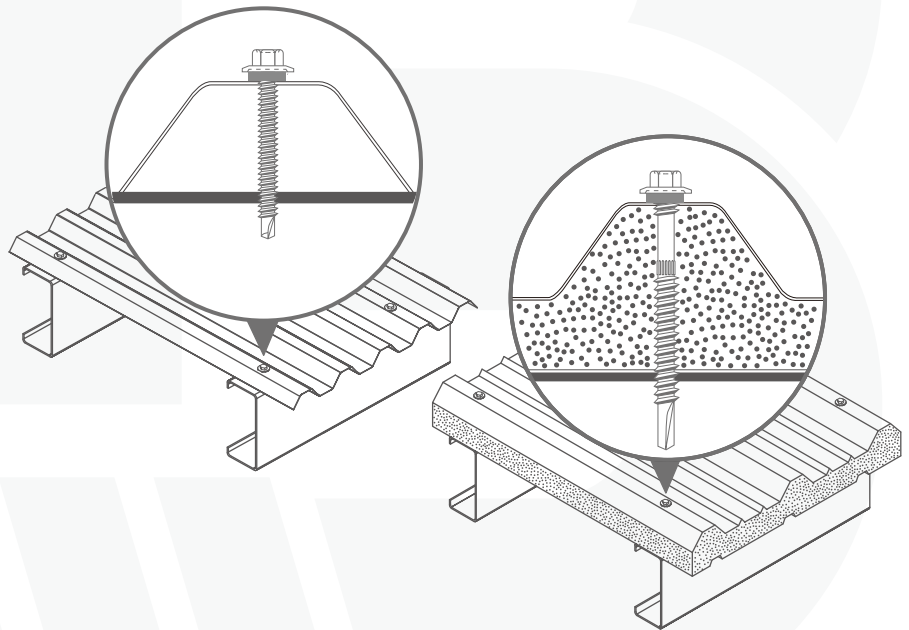

### PART NUMBER

#### Silver

##### FULL THREAD

BS-SDHCG1245C3N	12-14 x 45mm
BS-SDHCG1255C3N	12-14 x 55mm
BS-SDHCG1265C3N	12-14 x 65mm
BS-SDHCG1275C3N	12-14 x 75mm

##### DOUBLE THREAD

BS-SDHC1245C3N	12-14 x 45mm
BS-SDHC1255C3N	12-14 x 55mm
BS-SDHC1265C3N	12-14 x 65mm
BS-SDHC1275C3N	12-14 x 75mm

\*For size not indicated below, please contact for further information

## STITCHING FASTENERS

Carbon steel fasteners for fixing steel sheets into steel substrates

### STEEL PENETRATION

Max 1.0mm thick

### ADAPTER TO USE

Magnetic Hex Socket (5/16" )

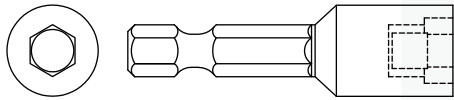

### PRODUCT FEATURES

Hex Washer Flange

Needle Point

### WASHER

True Blue DEKS Blue Seal Washer



### PART NUMBER

#### Silver

BS-SDHST1019C3N 10-16 x 19mm

BS-SDHST1025C3N 10-16 x 25mm

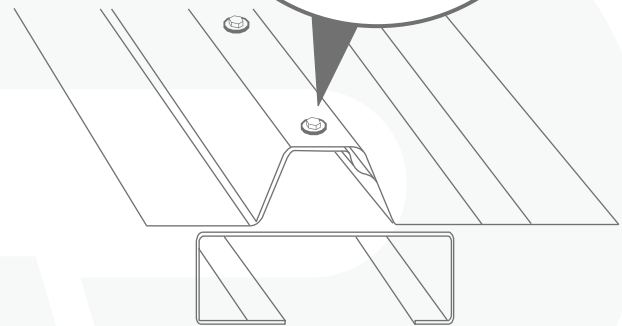
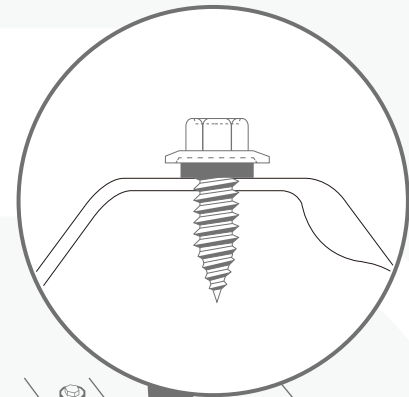
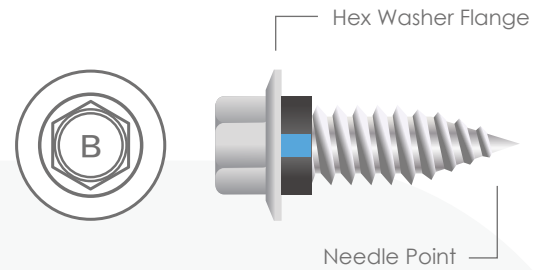

## CONCEALED FIXING FASTENERS

Carbon steel fasteners for fixing steel sheets into steel substrates

### STEEL PENETRATION

Max 4.0mm thick

### ADAPTER TO USE

Philips Bit (PH2+)

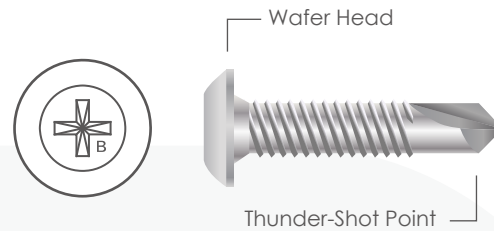
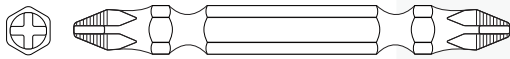

### PRODUCT FEATURES

Wafer Head

Philips Drive

Thunder-Shot Point

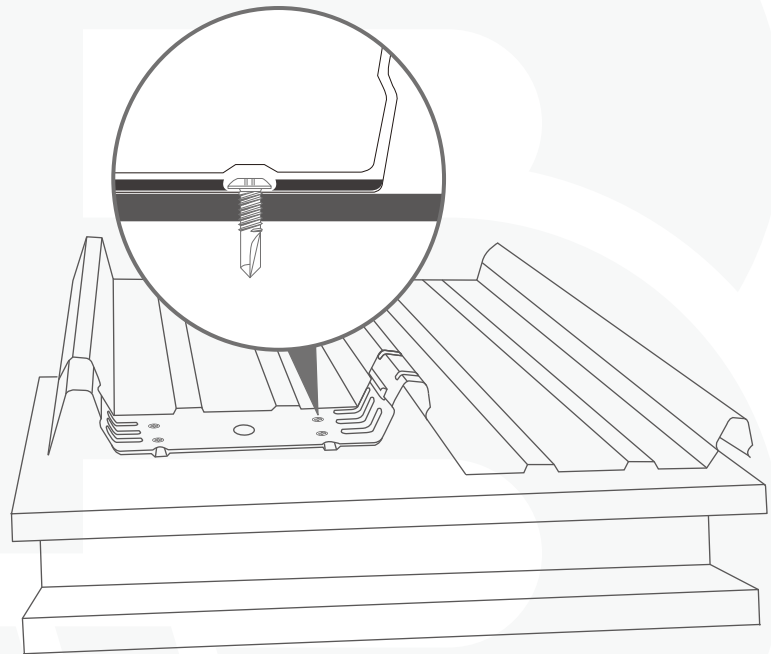

### PART NUMBER

#### Silver

BS-SDWF1022C3 10-24 x 22mm

\*For size not indicated below, please contact for further information

## VALLEY FIXING FASTENERS

Carbon steel fasteners for fixing steel sheets into timber substrates

### TIMBER PENETRATION

Min 20mm penetration

### ADAPTER TO USE

Magnetic Hex Socket (5/16" )

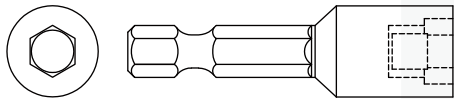

### PRODUCT FEATURES

Hex Washer Flange

Type 17 Sharp Point

### WASHER

True Blue DEKS Blue Seal Washer



### PART NUMBER

#### Silver

BS-T17H1020C3N 10-12 x 20mm

BS-T17H1025C3N 10-12 x 25mm

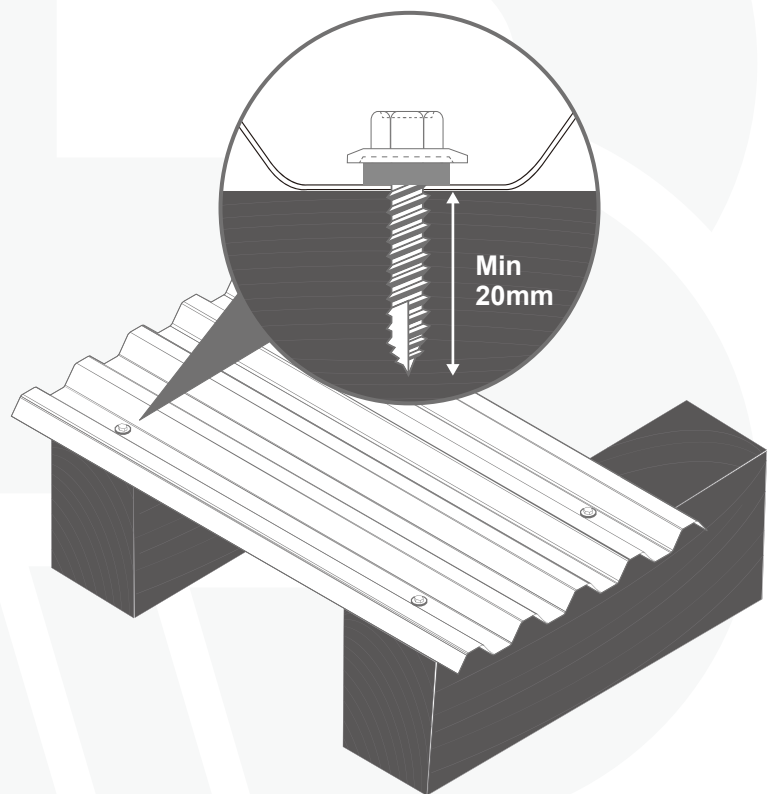
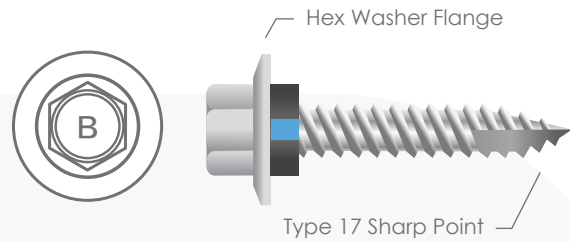



## CREST FIXING FASTENERS

Carbon steel fasteners for fixing steel sheets into timber substrates

### TIMBER PENETRATION

Min 25mm penetration

### ADAPTER TO USE

Magnetic Hex Socket (5/16" )

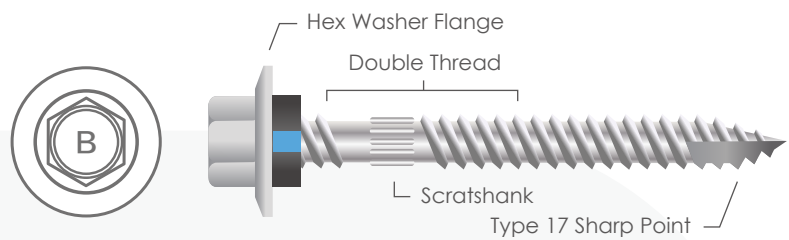
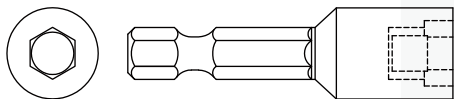

### PRODUCT FEATURES

Hex Washer Flange  
Type 17 Sharp Point  
Double Thread  
Scratchshank

### WASHER

True Blue DEKS Blue Seal Washer

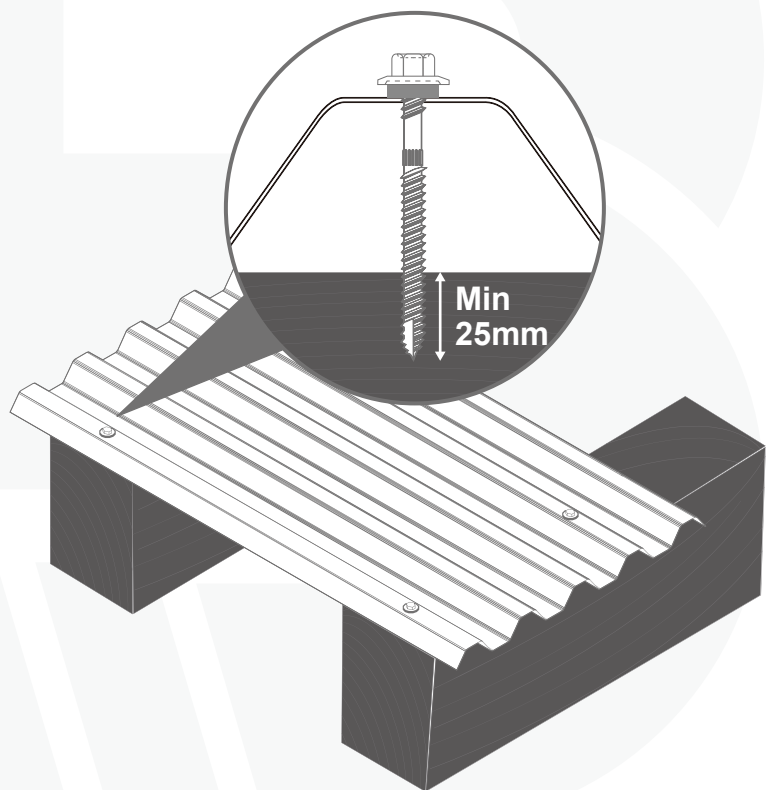

### PART NUMBER

#### Silver

BS-T17HCG1255C3N 12-11 x 55mm

## SKYLIGHT FIXING FASTENERS

Carbon steel fasteners for fixing skylight to steel substrates

### STEEL PENETRATION

Max 5.5mm Thick

### ADAPTER TO USE

Magnetic Hex Socket (5/16" )

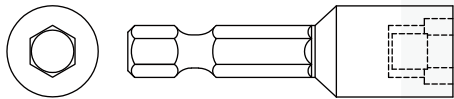

### PRODUCT FEATURES

Hex Washer Flange  
Expansion Wings  
Thunder-Shot Point

### WASHER

25mm Dome Grey EPDM



### PART NUMBER

#### Silver

BS-SDHCP1255C3D 12-14 x 55mm

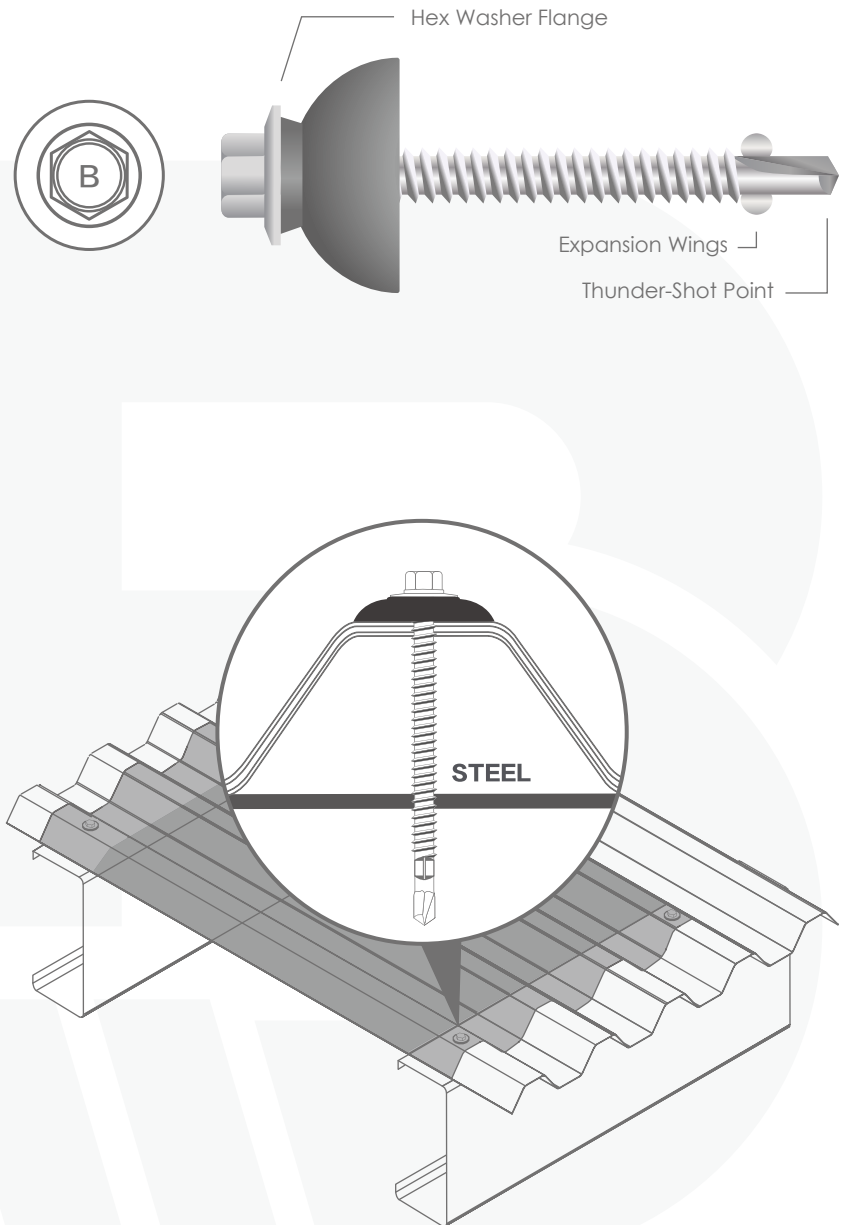

# Roofing Screw Selection Chart

## METAL-Tite

### VALLEY FIXING FASTENERS

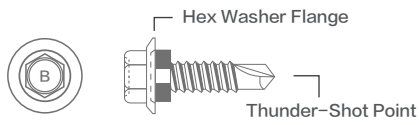

12-14 x 25mm  
12-14 x 35mm

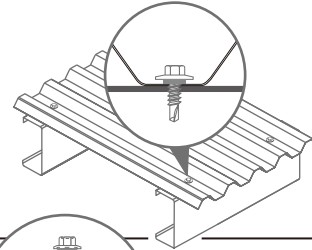

## METAL-Tite

### CREST FIXING FASTENERS

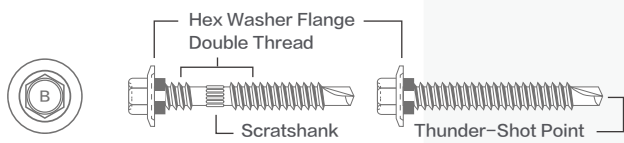

12-14 x 45mm  
12-14 x 55mm  
12-14 x 65mm  
12-14 x 75mm

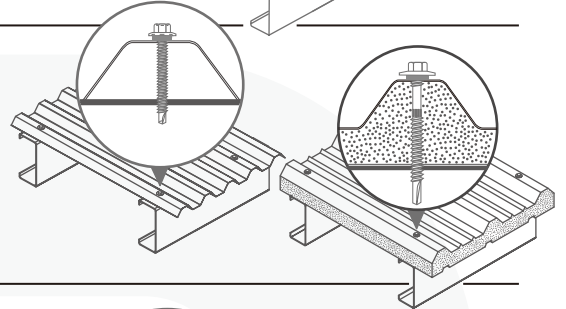

## METAL-Tite

### STITCHING FASTENERS

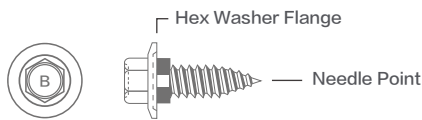

10-16 x 19mm  
10-16 x 25mm

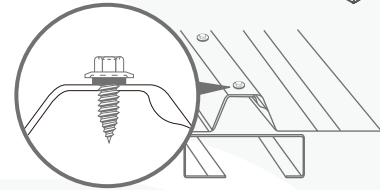

## METAL-Tite

### CONCEALED FIXING FASTENERS

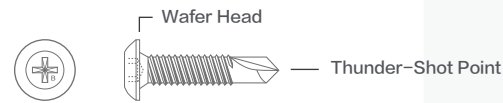

10-24 x 22mm

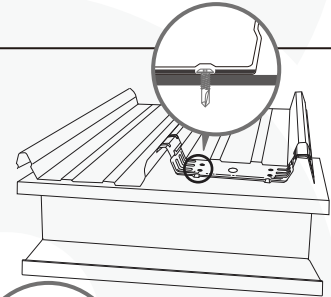

## TIMBER-Tite

### VALLEY FIXING FASTENERS

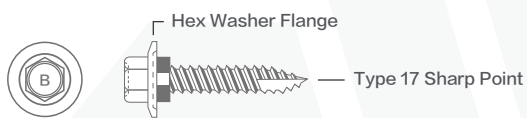

10-12 x 20mm  
10-12 x 25mm

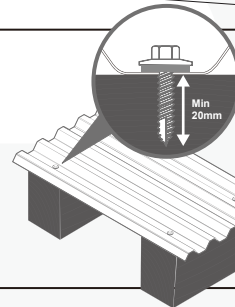

## TIMBER-Tite

### CREST FIXING FASTENERS

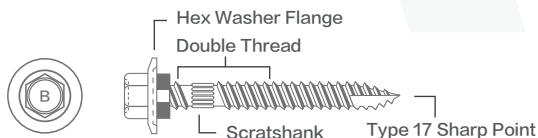

12-11 x 55mm

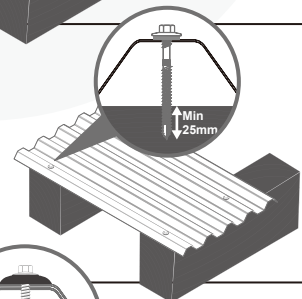

## POLYXPAND

### SKYLIGHT FIXING FASTENERS

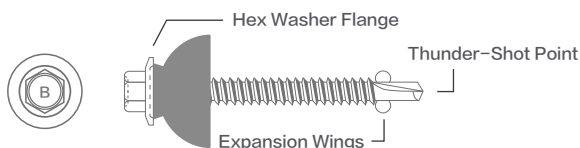

12-14 x 55mm

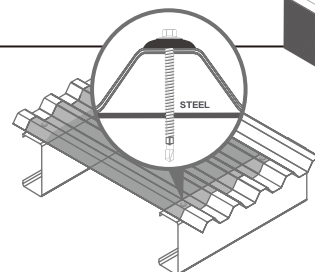

# Packaging Guide

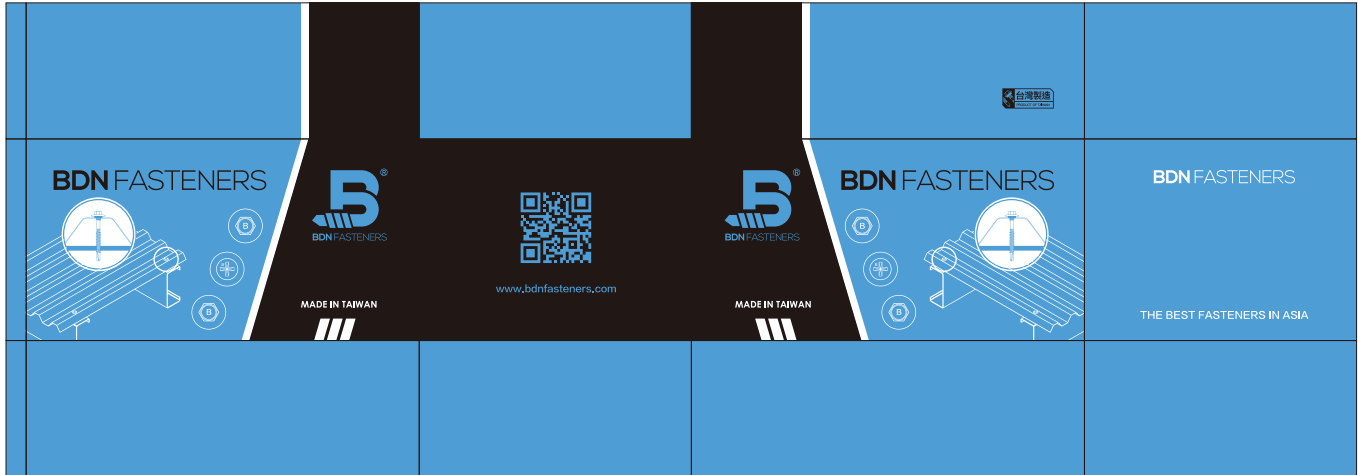

BDN FASTENERS product labels are always placed at the center of the box.

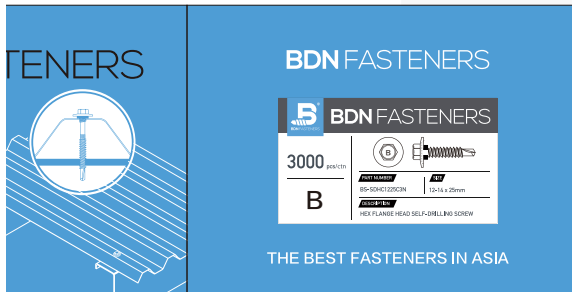

## PRODUCT LABEL

BDN FASTENERS come with large, easy to read product labels. Each product has its own unique label showing the product category, packaged quantity, size, part no., color and description.

To re-order, quote the Part No., Product Description, and Color Code as indicated below. This information can be easily obtained from existing packaging.

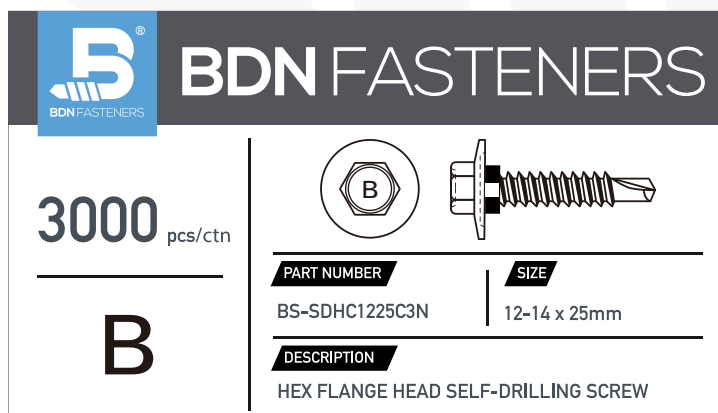

All BDN FASTENERS product labels must be placed at the designated area on the carton as stated below.

**! DO NOT!**

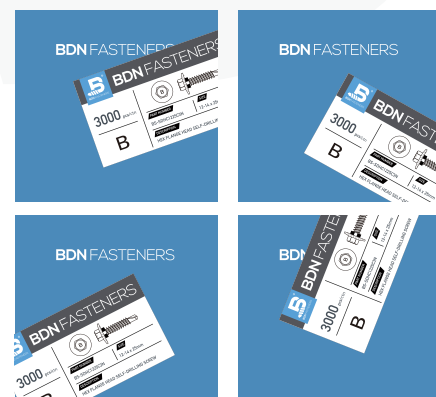



**BDN FASTENERS**

# SCREW PRODUCT GUIDE

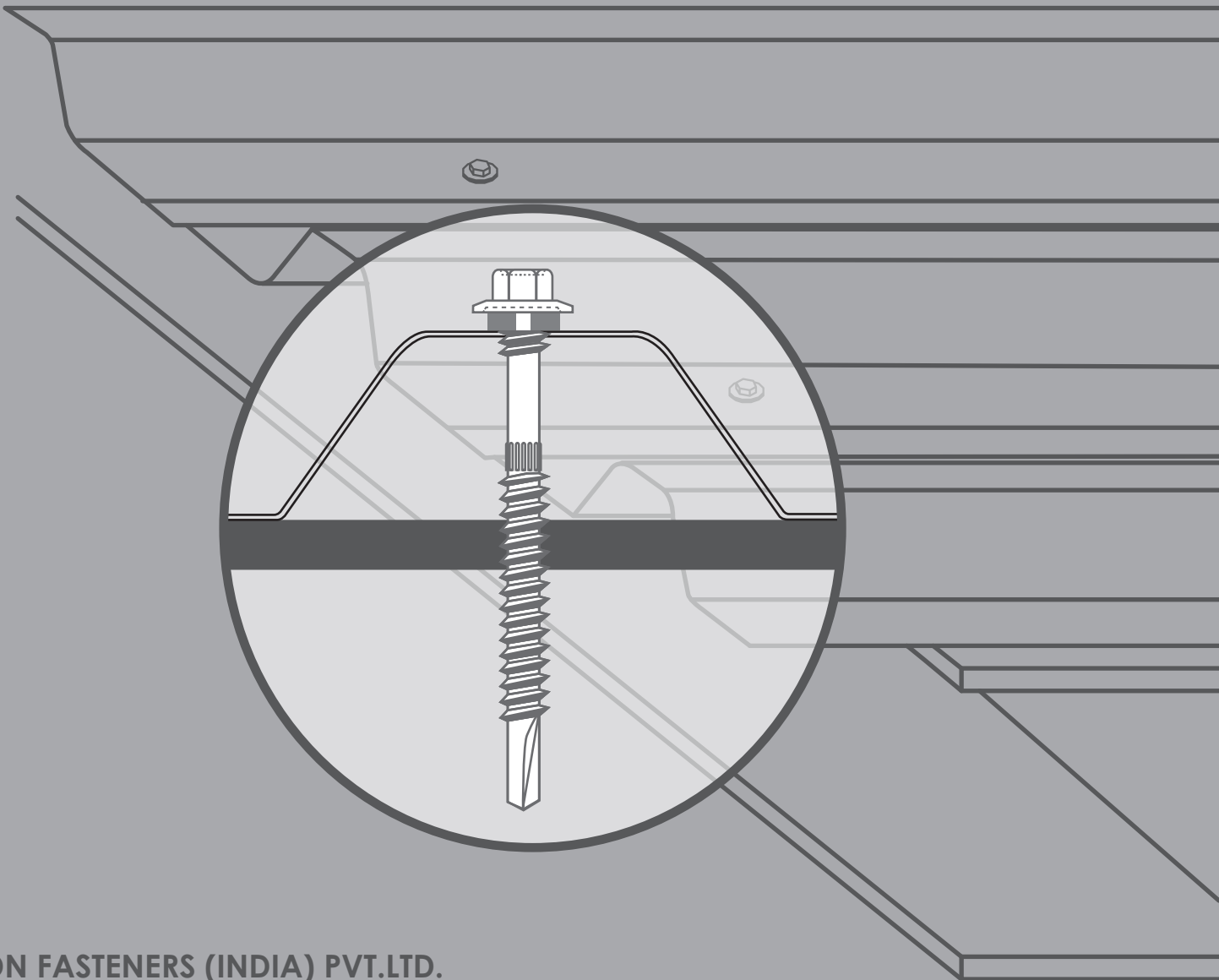
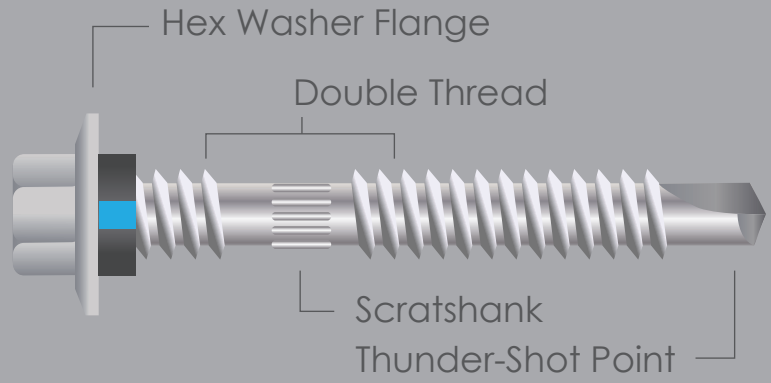

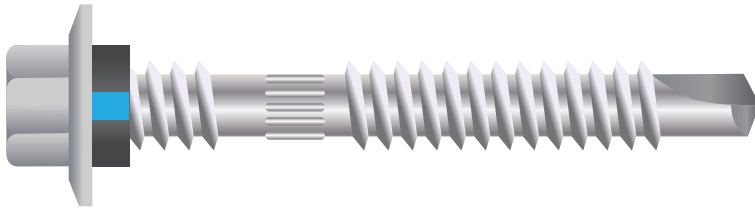

## Silver Coating

Silver Coating consists of multiple layers of specially formulated, corrosion resistant chemicals, comes with an impressive 40 year warranty, and can easily withstand 1000hrs of salt spray test (AS 2331.3.1-2001), and 15 Kesternich cycles (DIN50018 2.0 SFW).

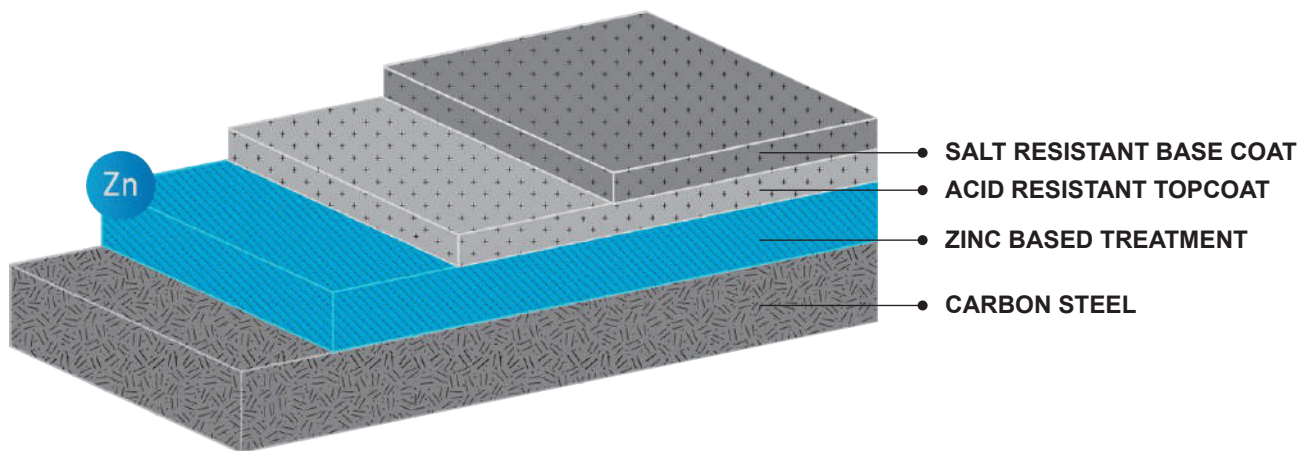

Coating Thickness: 18-25um

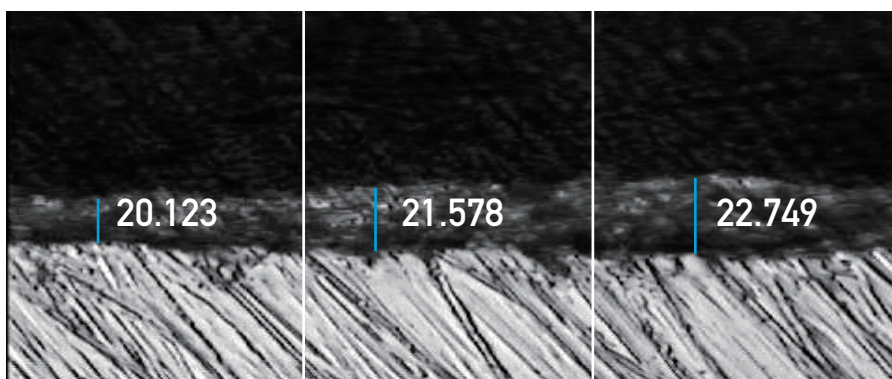

BDN FASTENERS (INDIA) PVT. LTD. hereby confirms that the above product has been manufactured in accordance with Australian Standard AS 3566.2:2002 Class 3, and warrants that the product will perform as detailed below, when conditions described are met.

## The warranty

Characteristics	Warranty Period
<p><b>Dry, Rural Areas</b></p> <ul style="list-style-type: none"> <li>Areas remote from the coast and sources of pollution; excluding all of areas listed below.</li> </ul>	<b>40 YEARS</b>
<p><b>Mild Urban or Rural Areas</b></p> <ul style="list-style-type: none"> <li>Areas with little to no chemical pollution, including but not limited to natural chemicals such as ammonia from livestock or carbon monoxide from log-fire.</li> <li>Areas far from the coast with no impact from salt water spray.</li> <li>Areas at least 2 kilometers away from any type of industry, light or heavy.</li> </ul>	<b>30 YEARS</b>
<p><b>Light Industrial or Urban Areas</b></p> <ul style="list-style-type: none"> <li>Urban</li> <li>Areas at least 1-2 kilometers away from light industrial or urban areas.</li> </ul>	<b>15 YEARS</b>
<p><b>Small Industrial Zones</b></p> <ul style="list-style-type: none"> <li>Areas located in or adjacent to small industrial zones.</li> </ul>	<b>10 YEARS</b>
<p><b>Coastal Areas</b></p> <ul style="list-style-type: none"> <li>Areas located approximately 2 kilometers from the coast.</li> </ul>	<b>5 YEARS</b>

## Warranty Terms and Conditions

- BDN FASTENERS guarantees that within the scope of warranty categorized in the environmental characteristics, the characteristics of the screw should not alter due to corrosion or surface treatment failure.
- Should any damage occur in the state mentioned in 1., the customer will be compensated with screws of the same specification, and with the same or equivalent coating.
- Any warranty claim should be notified in written form and executed only after the damaged goods have been inspected by authorized or BDN FASTENERS appointed third party personnel.
- The scope of this warranty does extend to nor include indirect or collateral damages.
- The warranty is void if damages are found to be deliberate either during or after installation or via with chemicals (e.g. Direct contact with wet concrete). Screws that were stored incorrectly prior to installation or used for the wrong application will also void warranty.
- This is a non transferable limited warranty which is only valid for the original owner/buyer.



Material & Engineering Laboratory-Kaohsiung

## Test Report



Report No. : KK-18-06743X

Date of Report : Jul, 24, 2018

**Applicant** BDN Fasteners  
**Product Description** Hex Flange Head Self-drilling Screw, "B" mark  
**Size** 12-14x55mm  
**Date of Sample Received** June. 11, 2018  
**Date of Testing** June. 11, 2018~ Jul. 23, 2018  
**Testing Method** AS 2331.3.1-2001 Neutral Salt Spray Test (NSS Test)

### Test Results :

Salt Spray Test:

Specimen Name	Before Test	After Test
Hex Flange Head Self-drilling Screw, "B" mark (12-14x55mm)	As attached photo	No red rust and no blisteing appeared on the specimen after test for 1000 hours. As attached photo

Test Result:



Specimen Name: Hex Flange Head Self-drilling Screw, "B" mark (12-14x55mm) Before Test



Specimen Name: Hex Flange Head Self-drilling Screw, "B" mark (12-14x55mm) After 1000hr Test





Material & Engineering Laboratory-Kaohsiung

## Test Report



Report No. : KK-18-06712X

Date of Report : July. 08, 2018

**Applicant** BDN Fasteners  
**Product Description** Hex Flange Head Self-drilling Screw, "B" mark  
**Size** 12-14x55mm  
**Date of Sample Received** June. 11, 2018  
**Date of Testing** June. 11, 2018~July. 06, 2018  
**Testing Method** DIN 50018 2.0L (SO2) Kesternich Test

### Test Results :

Kesternich Test

Specimen Name	Before Test	After Test
Hex Flange Head Self-drilling Screw, "B" mark (12-14x55mm)	As attached photo	No red rust and no blisteing appeared on the specimen after test for 15 cycles. As attached photo

Test Result:



Specimen Name: Hex Flange Head Self-drilling Screw, "B" mark (12-14x55mm)

Before Test



Specimen Name: Hex Flange Head Self-drilling Screw, "B" mark (12-14x55mm)

After 15 Cycles



## BDN FASTENERS INDIA

### BDN FASTENERS (INDIA) PVT.LTD.

D-62, SECTOR 48, NOIDA,  
GAUTAM BUDDHA NAGAR,  
UTTAR PRADESH- 201301, INDIA  
Mobile: +91-9999166006  
+ 91-8826176665, +91-9717235000  
E-mail: sales@bdfasteners.in  
romil@bdfasteners.in  
gaurav@bdfasteners.in  
www.bdfasteners.in



### HEADQUARTER BDN FASTENERS TAIWAN

NO.126, SEC 2, HETI RD., GANGSHAN,  
KAOHSIUNG 820, TAIWAN (R.O.C)  
T. +886-7-6295690 F. +886-7-6295692  
E-mail: info@bdfasteners.com  
www.bdfasteners.com



Authorized Dealer



### KANTILAL & BROTHERS VADODARA

Manibhuvan, Golwadnaka,  
LN Road, Vadodara. (Gujarat)  
India-390001  
(M) - 8460616032/9601299511  
(E) - info@kbfasteners.in  
(W) - www.kbfasteners.in