



# **Kawasaki Ninja ZX-10R**



## **Motorcycle Service Manual**



# Quick Reference Guide

<b>General Information</b>	<b>1</b>
<b>Periodic Maintenance</b>	<b>2</b>
<b>Fuel System (DFI)</b>	<b>3</b>
<b>Cooling System</b>	<b>4</b>
<b>Engine Top End</b>	<b>5</b>
<b>Clutch</b>	<b>6</b>
<b>Engine Lubrication System</b>	<b>7</b>
<b>Engine Removal/Installation</b>	<b>8</b>
<b>Crankshaft/Transmission</b>	<b>9</b>
<b>Wheels/Tires</b>	<b>10</b>
<b>Final Drive</b>	<b>11</b>
<b>Brakes</b>	<b>12</b>
<b>Suspension</b>	<b>13</b>
<b>Steering</b>	<b>14</b>
<b>Frame</b>	<b>15</b>
<b>Electrical System</b>	<b>16</b>
<b>Appendix</b>	<b>17</b>

This quick reference guide will assist you in locating a desired topic or procedure.

- Bend the pages back to match the black tab of the desired chapter number with the black tab on the edge at each table of contents page.
- Refer to the sectional table of contents for the exact pages to locate the specific topic required.







**Ninja ZX-10R**

# **Motorcycle Service Manual**

---

All rights reserved. No parts of this publication may be reproduced, stored in a retrieval system, or transmitted in any form or by any means, electronic mechanical photocopying, recording or otherwise, without the prior written permission of Quality Assurance Department/Consumer Products & Machinery Company/Kawasaki Heavy Industries, Ltd., Japan.

No liability can be accepted for any inaccuracies or omissions in this publication, although every possible care has been taken to make it as complete and accurate as possible.

The right is reserved to make changes at any time without prior notice and without incurring an obligation to make such changes to products manufactured previously. See your Motorcycle dealer for the latest information on product improvements incorporated after this publication.

All information contained in this publication is based on the latest product information available at the time of publication. Illustrations and photographs in this publication are intended for reference use only and may not depict actual model component parts.

## LIST OF ABBREVIATIONS

A	ampere(s)	lb	pound(s)
ABDC	after bottom dead center	m	meter(s)
AC	alternating current	min	minute(s)
ATDC	after top dead center	N	newton(s)
BBDC	before bottom dead center	Pa	pascal(s)
BDC	bottom dead center	PS	horsepower
BTDC	before top dead center	psi	pound(s) per square inch
°C	degree(s) Celsius	r	revolution
DC	direct current	rpm	revolution(s) per minute
F	farad(s)	TDC	top dead center
°F	degree(s) Fahrenheit	TIR	total indicator reading
ft	foot, feet	V	volt(s)
g	gram(s)	W	watt(s)
h	hour(s)	Ω	ohm(s)
L	liter(s)		

**Read OWNER'S MANUAL before operating.**

## EMISSION CONTROL INFORMATION

To protect the environment in which we all live, Kawasaki has incorporated crankcase emission (1) and exhaust emission (2) control systems in compliance with applicable regulations of the United States Environmental Protection Agency and California Air Resources Board. Additionally, Kawasaki has incorporated an evaporative emission control system (3) in compliance with applicable regulations of the California Air Resources Board on vehicles sold in California only.

### 1. Crankcase Emission Control System

This system eliminates the release of crankcase vapors into the atmosphere. Instead, the vapors are routed through an oil separator to the inlet side of the engine. While the engine is operating, the vapors are drawn into combustion chamber, where they are burned along with the fuel and air supplied by the fuel injection system.

### 2. Exhaust Emission Control System

This system reduces the amount of pollutants discharged into the atmosphere by the exhaust of this motorcycle. The fuel, ignition, and exhaust systems of this motorcycle have been carefully designed and constructed to ensure an efficient engine with low exhaust pollutant levels.

The exhaust system of this model motorcycle manufactured primarily for sale in California includes a catalytic converter system.

### 3. Evaporative Emission Control System

Vapors caused by fuel evaporation in the fuel system are not vented into the atmosphere. Instead, fuel vapors are routed into the running engine to be burned, or stored in a canister when the engine is stopped. Liquid fuel is caught by a vapor separator and returned to the fuel tank.

The Clean Air Act, which is the Federal law covering motor vehicle pollution, contains what is commonly referred to as the Act's "tampering provisions."

"Sec. 203(a) The following acts and the causing thereof are prohibited...

(3)(A) for any person to remove or render inoperative any device or element of design installed on or in a motor vehicle or motor vehicle engine in compliance with regulations under this title prior to its sale and delivery to the ultimate purchaser, or for any manufacturer or dealer knowingly to remove or render inoperative any such device or element of design after such sale and delivery to the ultimate purchaser.

(3)(B) for any person engaged in the business of repairing, servicing, selling, leasing, or trading motor vehicles or motor vehicle engines, or who operates a fleet of motor vehicles knowingly to remove or render inoperative any device or element of design installed on or in a motor vehicle or motor vehicle engine in compliance with regulations under this title following its sale and delivery to the ultimate purchaser..."

### NOTE

○The phrase "remove or render inoperative any device or element of design" has been generally interpreted as follows:

1. Tampering does not include the temporary removal or rendering inoperative of devices or elements of design in order to perform maintenance.

2. Tampering could include:

a. Maladjustment of vehicle components such that the emission standards are exceeded.

b. Use of replacement parts or accessories which adversely affect the performance or durability of the motorcycle.

c. Addition of components or accessories that result in the vehicle exceeding the standards.

d. Permanently removing, disconnecting, or rendering inoperative any component or element of design of the emission control systems.

**WE RECOMMEND THAT ALL DEALERS OBSERVE THESE PROVISIONS OF FEDERAL LAW, THE VIOLATION OF WHICH IS PUNISHABLE BY CIVIL PENALTIES NOT EXCEEDING \$10,000 PER VIOLATION.**

## **TAMPERING WITH NOISE CONTROL SYSTEM PROHIBITED**

Federal law prohibits the following acts or the causing thereof: (1) The removal or rendering inoperative by any person other than for purposes of maintenance, repair, or replacement, of any device or element of design incorporated into any new vehicle for the purpose of noise control prior to its sale or delivery to the ultimate purchaser or while it is in use, or (2) the use of the vehicle after such device or element of design has been removed or rendered inoperative by any person.

Among those acts presumed to constitute tampering are the acts listed below:

- Replacement of the original exhaust system or muffler with a component not in compliance with Federal regulations.
- Removal of the muffler(s) or any internal portion of the muffler(s).
- Removal of the air box or air box cover.
- Modifications to the muffler(s) or air inlet system by cutting, drilling, or other means if such modifications result in increased noise levels.

# Foreword

This manual is designed primarily for use by trained mechanics in a properly equipped shop. However, it contains enough detail and basic information to make it useful to the owner who desires to perform his own basic maintenance and repair work. A basic knowledge of mechanics, the proper use of tools, and workshop procedures must be understood in order to carry out maintenance and repair satisfactorily. Whenever the owner has insufficient experience or doubts his ability to do the work, all adjustments, maintenance, and repair should be carried out only by qualified mechanics.

In order to perform the work efficiently and to avoid costly mistakes, read the text, thoroughly familiarize yourself with the procedures before starting work, and then do the work carefully in a clean area. Whenever special tools or equipment are specified, do not use makeshift tools or equipment. Precision measurements can only be made if the proper instruments are used, and the use of substitute tools may adversely affect safe operation.

**For the duration of the warranty period,** we recommend that all repairs and scheduled maintenance be performed in accordance with this service manual. Any owner maintenance or repair procedure not performed in accordance with this manual may void the warranty.

To get the longest life out of your vehicle:

- Follow the Periodic Maintenance Chart in the Service Manual.
- Be alert for problems and non-scheduled maintenance.
- Use proper tools and genuine Kawasaki Motorcycle parts. Special tools, gauges, and testers that are necessary when servicing Kawasaki motorcycles are introduced by the Special Tool Catalog or Manual. Genuine parts provided as spare parts are listed in the Parts Catalog.
- Follow the procedures in this manual carefully. Don't take shortcuts.
- Remember to keep complete records of maintenance and repair with dates and any new parts installed.

---

## How to Use This Manual

---

In this manual, the product is divided into its major systems and these systems make up the manual's chapters.

The Quick Reference Guide shows you all of the product's system and assists in locating their chapters. Each chapter in turn has its own comprehensive Table of Contents.

For example, if you want ignition coil information, use the Quick Reference Guide to locate the Electrical System chapter. Then, use the Table of Contents on the first page of the chapter to find the ignition coil section.

Whenever you see these WARNING and CAUTION symbols, heed their instructions! Always follow safe operating and maintenance practices.

### WARNING

**This warning symbol identifies special instructions or procedures which, if not correctly followed, could result in personal injury, or loss of life.**

### CAUTION

**This caution symbol identifies special instructions or procedures which, if not strictly observed, could result in damage to or destruction of equipment.**

This manual contains four more symbols (in addition to WARNING and CAUTION) which will help you distinguish different types of information.

### NOTE

○ *This note symbol indicates points of particular interest for more efficient and convenient operation.*

- Indicates a procedural step or work to be done.
- Indicates a procedural sub-step or how to do the work of the procedural step it follows. It also precedes the text of a NOTE.
- ★ Indicates a conditional step or what action to take based on the results of the test or inspection in the procedural step or sub-step it follows.

In most chapters an exploded view illustration of the system components follows the Table of Contents. In these illustrations you will find the instructions indicating which parts require specified tightening torque, oil, grease or a locking agent during assembly.



# General Information



## Table of Contents

Before Servicing .....	1-2
Model Identification.....	1-7
General Specifications.....	1-9
Technical Information-Immobilizer System .....	1-12
Technical Information-Exhaust Device System .....	1-15
Technical Information.....	1-16
Unit Conversion Table .....	1-17

# 1-2 GENERAL INFORMATION

## Before Servicing

Before starting to perform an inspection service or carry out a disassembly and reassembly operation on a motorcycle, read the precautions given below. To facilitate actual operations, notes, illustrations, photographs, cautions, and detailed descriptions have been included in each chapter wherever necessary. This section explains the items that require particular attention during the removal and reinstallation or disassembly and reassembly of general parts.

Especially note the following:

### *Battery Ground*

Before completing any service on the motorcycle, disconnect the battery wires from the battery to prevent the engine from accidentally turning over. Disconnect the negative (-) first and then the positive (+). When completed with the service, first connect the positive (+) wire to the positive (+) terminal of the battery then the negative (-) wire to the negative terminal.

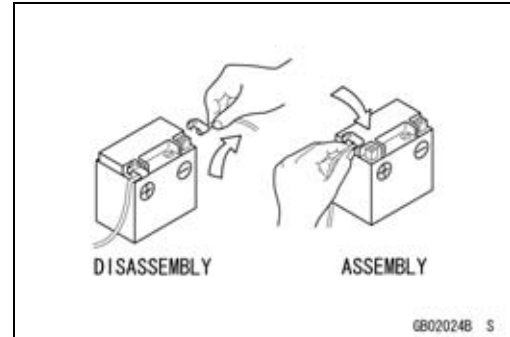

### *Edges of Parts*

Lift large or heavy parts wearing gloves to prevent injury from possible sharp edges on the parts.

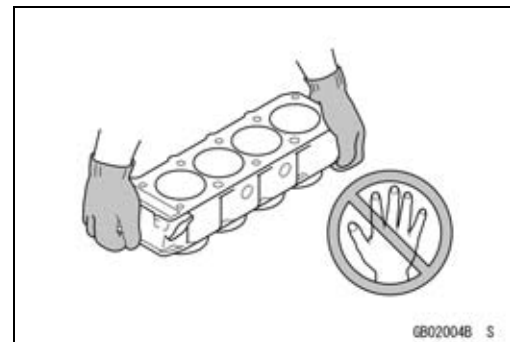

### *Solvent*

Use a high flash point solvent when cleaning parts. High flash point solvent should be used according to directions of the solvent manufacturer.

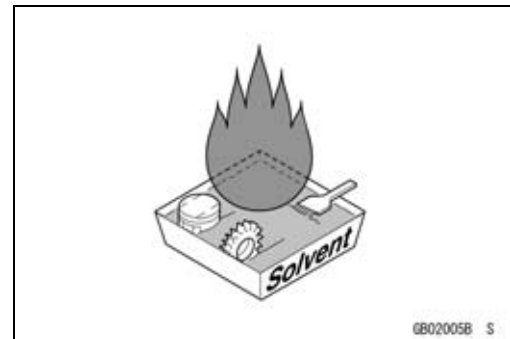

### *Cleaning vehicle before disassembly*

Clean the vehicle thoroughly before disassembly. Dirt or other foreign materials entering into sealed areas during vehicle disassembly can cause excessive wear and decrease performance of the vehicle.

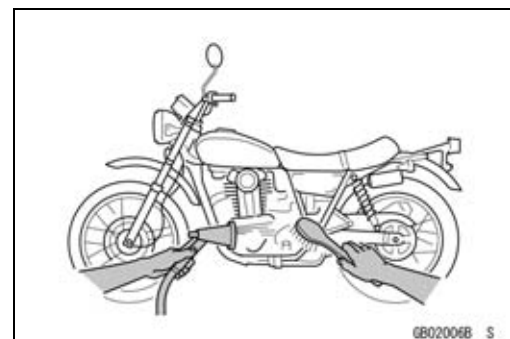



**Before Servicing**

*Arrangement and Cleaning of Removed Parts*

Disassembled parts are easy to confuse. Arrange the parts according to the order the parts were disassembled and clean the parts in order prior to assembly.

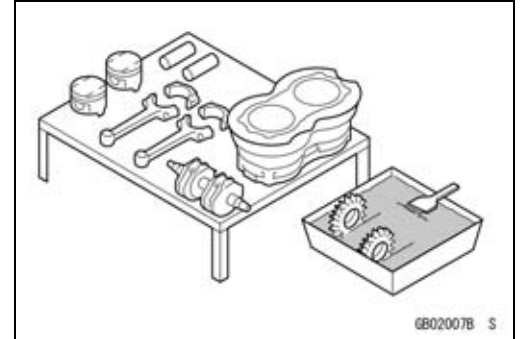

*Storage of Removed Parts*

After all the parts including subassembly parts have been cleaned, store the parts in a clean area. Put a clean cloth or plastic sheet over the parts to protect from any foreign materials that may collect before re-assembly.

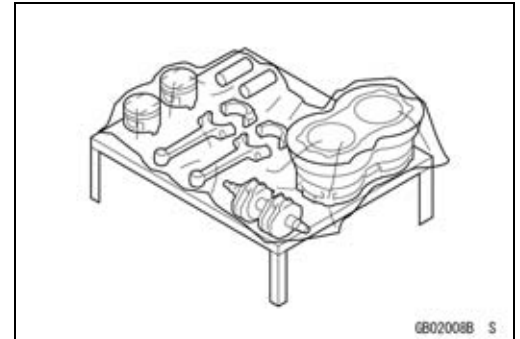

*Inspection*

Reuse of worn or damaged parts may lead to serious accident. Visually inspect removed parts for corrosion, discoloration, or other damage. Refer to the appropriate sections of this manual for service limits on individual parts. Replace the parts if any damage has been found or if the part is beyond its service limit.

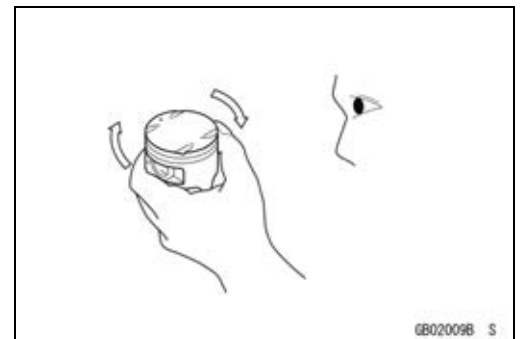

*Replacement Parts*

Replacement Parts must be KAWASAKI genuine or recommended by KAWASAKI. Gaskets, O-rings, Oil seals, Grease seals, circlips or cotter pins must be replaced with new ones whenever disassembled.

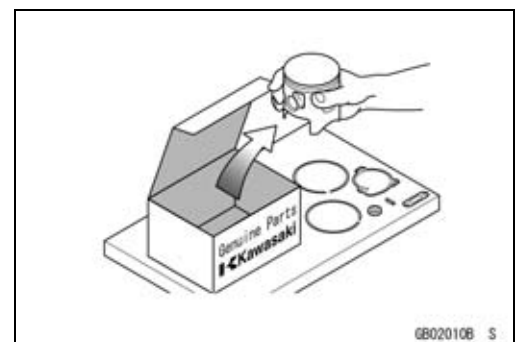

*Assembly Order*

In most cases assembly order is the reverse of disassembly, however, if assembly order is provided in this Service Manual, follow the procedures given.

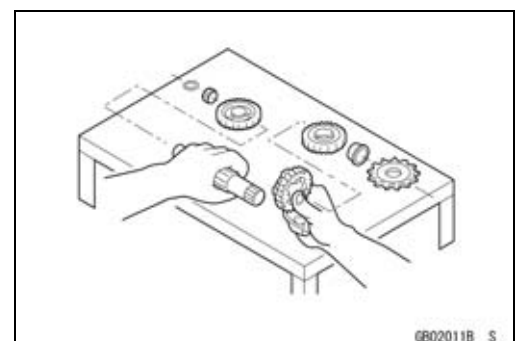

# 1-4 GENERAL INFORMATION

## Before Servicing

### *Tightening Sequence*

Generally, when installing a part with several bolts, nuts, or screws, start them all in their holes and tighten them to a snug fit. Then tighten them according to the specified sequence to prevent case warpage or deformation which can lead to malfunction. Conversely when loosening the bolts, nuts, or screws, first loosen all of them by about a quarter turn and then remove them. If the specified tightening sequence is not indicated, tighten the fasteners alternating diagonally.

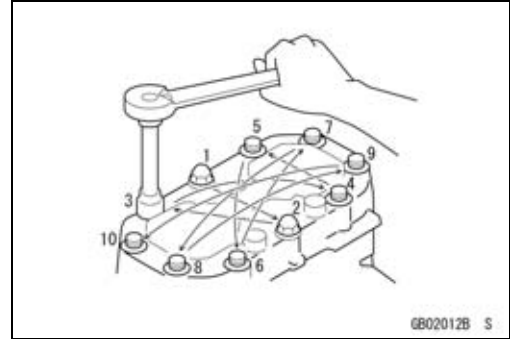

### *Tightening Torque*

Incorrect torque applied to a bolt, nut, or screw may lead to serious damage. Tighten fasteners to the specified torque using a good quality torque wrench.

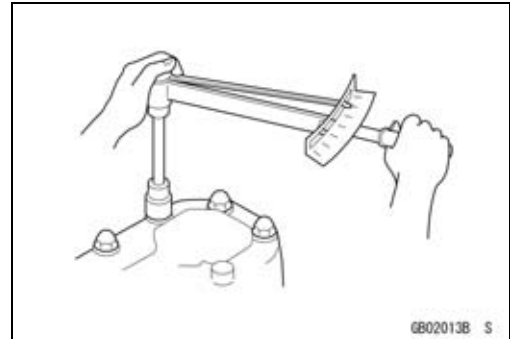

### *Force*

Use common sense during disassembly and assembly, excessive force can cause expensive or hard to repair damage. When necessary, remove screws that have a non-permanent locking agent applied using an impact driver. Use a plastic-faced mallet whenever tapping is necessary.

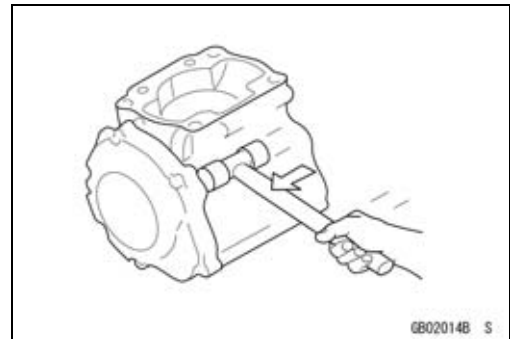

### *Gasket, O-ring*

Hardening, shrinkage, or damage of both gaskets and O-rings after disassembly can reduce sealing performance. Remove old gaskets and clean the sealing surfaces thoroughly so that no gasket material or other material remains. Install new gaskets and replace used O-rings when re-assembling.

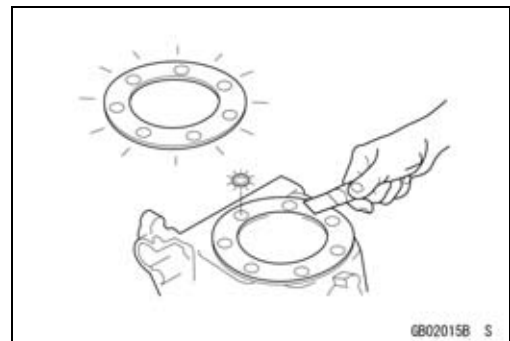

### *Liquid Gasket, Locking Agent*

For applications that require Liquid Gasket or a Locking agent, clean the surfaces so that no oil residue remains before applying liquid gasket or locking agent. Do not apply them excessively. Excessive application can clog oil passages and cause serious damage.



**Before Servicing**

*Press*

For items such as bearings or oil seals that must be pressed into place, apply small amount of oil to the contact area. Be sure to maintain proper alignment and use smooth movements when installing.

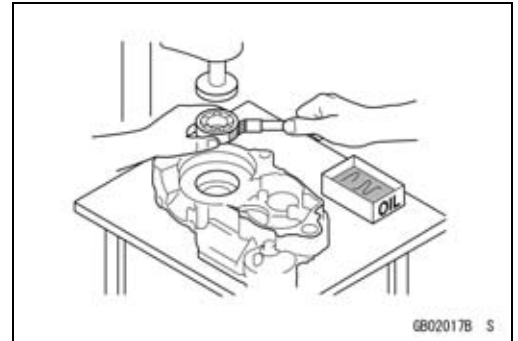

*Ball Bearing and Needle Bearing*

Do not remove pressed ball or needle unless removal is absolutely necessary. Replace with new ones whenever removed. Press bearings with the manufacturer and size marks facing out. Press the bearing into place by putting pressure on the correct bearing race as shown.

Pressing the incorrect race can cause pressure between the inner and outer race and result in bearing damage.

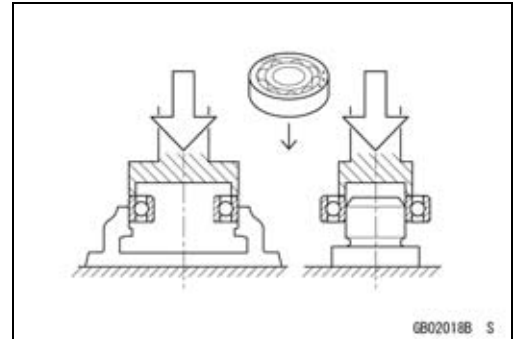

*Oil Seal, Grease Seal*

Do not remove pressed oil or grease seals unless removal is necessary. Replace with new ones whenever removed. Press new oil seals with manufacture and size marks facing out. Make sure the seal is aligned properly when installing.

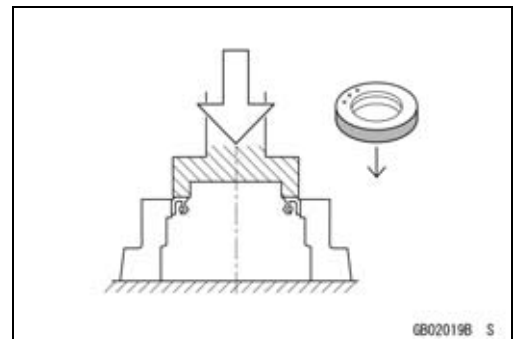

Apply specified grease to lip of seal before installing the seal.

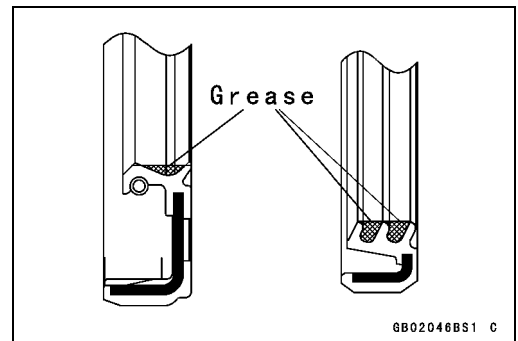

*Circlips, Cotter Pins*

Replace circlips or cotter pins that were removed with new ones. Take care not to open the clip excessively when installing to prevent deformation.

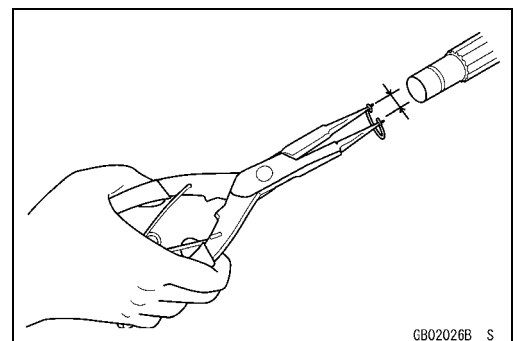

## 1-6 GENERAL INFORMATION

### Before Servicing

#### *Lubrication*

It is important to lubricate rotating or sliding parts during assembly to minimize wear during initial operation. Lubrication points are called out throughout this manual, apply the specific oil or grease as specified.

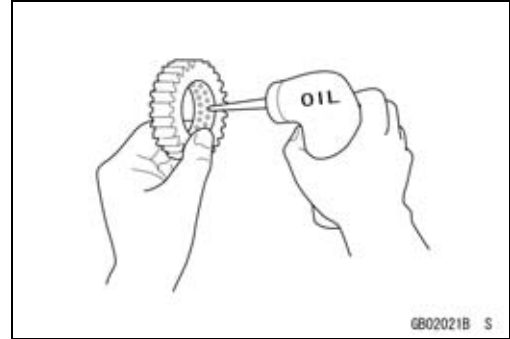

#### *Direction of Engine Rotation*

When rotating the crankshaft by hand, the free play amount of rotating direction will affect the adjustment. Rotate the crankshaft to positive direction (clockwise viewed from output side).

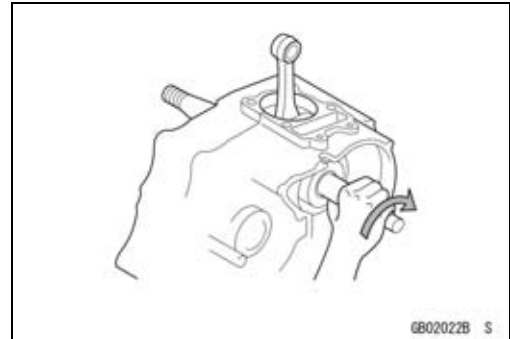

#### *Electrical Wires*

A two-color wire is identified first by the primary color and then the stripe color. Unless instructed otherwise, electrical wires must be connected to those of the same color.

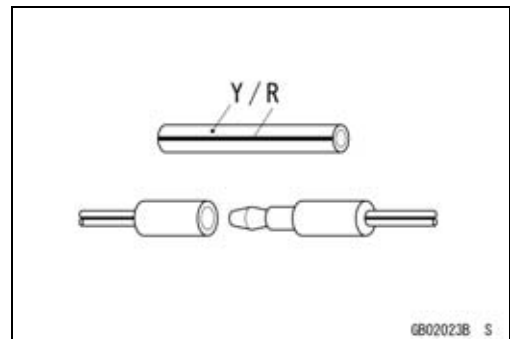

Model Identification

ZX1000-C1 (Europe) Left Side View



ZX1000-C1 (Europe) Right Side View



# 1-8 GENERAL INFORMATION

## Model Identification

### ZX1000-C1 (US and Canada) Left Side View



### ZX1000-C1 (US and Canada) Right Side View



**General Specifications**

Items	ZX1000-C1 ~
<b>Dimensions</b> Overall Length Overall Width Overall Height Wheelbase Road Clearance Seat Height Dry Mass Curb Mass: Front Rear Fuel Tank Capacity	2 045 mm (80.5 in.) 705 mm (27.8 in.) 1 115 mm (43.9 in.) 1 385 mm (54.5 in.) 125 mm (4.9 in.) 825 mm (32.5 in.) 170 kg (375 lb) 102 kg (225 lb) 94 kg (207 lb) 17 L (4.5 US gal)
<b>Performance</b> Minimum Turning Radius	3.3 m (10.8 ft)
<b>Engine</b> Type Cooling System Bore and Stroke Displacement Compression Ratio Maximum Horsepower  Maximum Torque  Carburetion System Starting System Ignition System Timing Advance Ignition Timing Spark Plug Cylinder Numbering Method Firing Order Valve Timing: Inlet: Open Close Duration Exhaust: Open Close Duration Lubrication System	4-stroke, DOHC, 4-cylinder Liquid-cooled 76.0 × 55.0 mm (3.0 × 2.2 in.) 998 mL (60.9 cu in.) 12.7:1 128.4 kW (175 PS) @11 700 r/min (rpm), (FR) 78.2 kW (106 PS) @11 500 r/min (rpm), (CA), (CAL), (US) – – – 115 N·m (11.7 kgf·m, 49 ft·lb) @9 500 r/min (rpm), (CA), (CAL), (FR), (US) – – – FI (Fuel injection), MIKUNI 43EIDW Electric starter Battery and coil (transistorized) Electronically advanced (digital igniter in ECU) 10° BTDC @1 100 r/min (rpm) NGK CR9EIA-9 Left to right, 1-2-3-4 1-2-4-3  46° BTDC 74° ABDC 300°  66° BBDC 46° ATDC 292° Forced lubrication (wet sump with cooler)

# 1-10 GENERAL INFORMATION

## General Specifications

Items	ZX1000-C1 ~
Engine Oil: Type  Viscosity Capacity	API SE, SF or SG API SH or SJ with JASO MA SAE10W-40 3.7 L (3.9 US qt)
<b>Drive Train</b> Primary Reduction System: Type Reduction Ratio Clutch Type Transmission: Type Gear Ratios: 1st 2nd 3rd 4th 5th 6th Final Drive System: Type Reduction Ratio Overall Drive Ratio	Gear 1.611 (87/54) Wet multi disc 6-speed, constant mesh, return shift  2.533 (38/15) 2.053 (39/19) 1.737 (33/19) 1.524 (32/21) 1.381 (29/21) 1.304 (30/23)  Chain drive 2.294 (39/17) 4.821 @Top gear
<b>Frame</b> Type Caster (Rake Angle) Trail Front Tire: Type Size Rear Tire: Type Size Front Suspension: Type Wheel Travel Rear Suspension: Type Wheel Travel Brake Type: Front Rear	Tubular, diamond 24° 102 mm (4.0 in.)  Tubeless 120/70 ZR17 M/C (58W)  Tubeless 190/50 ZR17 M/C (73W)  Telescopic fork (upside-down) 120 mm (4.7 in.)  Swingarm (uni-trak) 125 mm (4.9 in.)  Dual discs Single disc



**General Specifications**

Items	ZX1000-C1 ~
<b>Electrical Equipment</b>	
Battery	12 V 10 Ah
Headlight:	
Type	Semi-sealed beam
Bulb:	
High	12 V 55 W (quartz-halogen) × 2
Low	12 V 55 W (quartz-halogen)
Tail/Brake Light	12 V 0.5/4.1 W (LED)
Alternator:	
Type	Three-phase AC
Rated Output	30.3 A, 14 V @5 000 r/min (rpm)

Specifications subject to change without notice, and may not apply to every country.

CA: Canada Model

CAL: California Model

FR: France Model

US: United States Model

# 1-12 GENERAL INFORMATION

## Technical Information-Immobilizer System

### Overview

This system provides a theft proof device by means of matching a code between the inbuilt key transponder and the ECU (Electronic Control Unit). If this code does not match, the fuel pump, injectors, ignition system, sub-throttle valve actuator and exhaust butterfly valve actuator will not operate and the engine will not start.

### Related Parts and Function

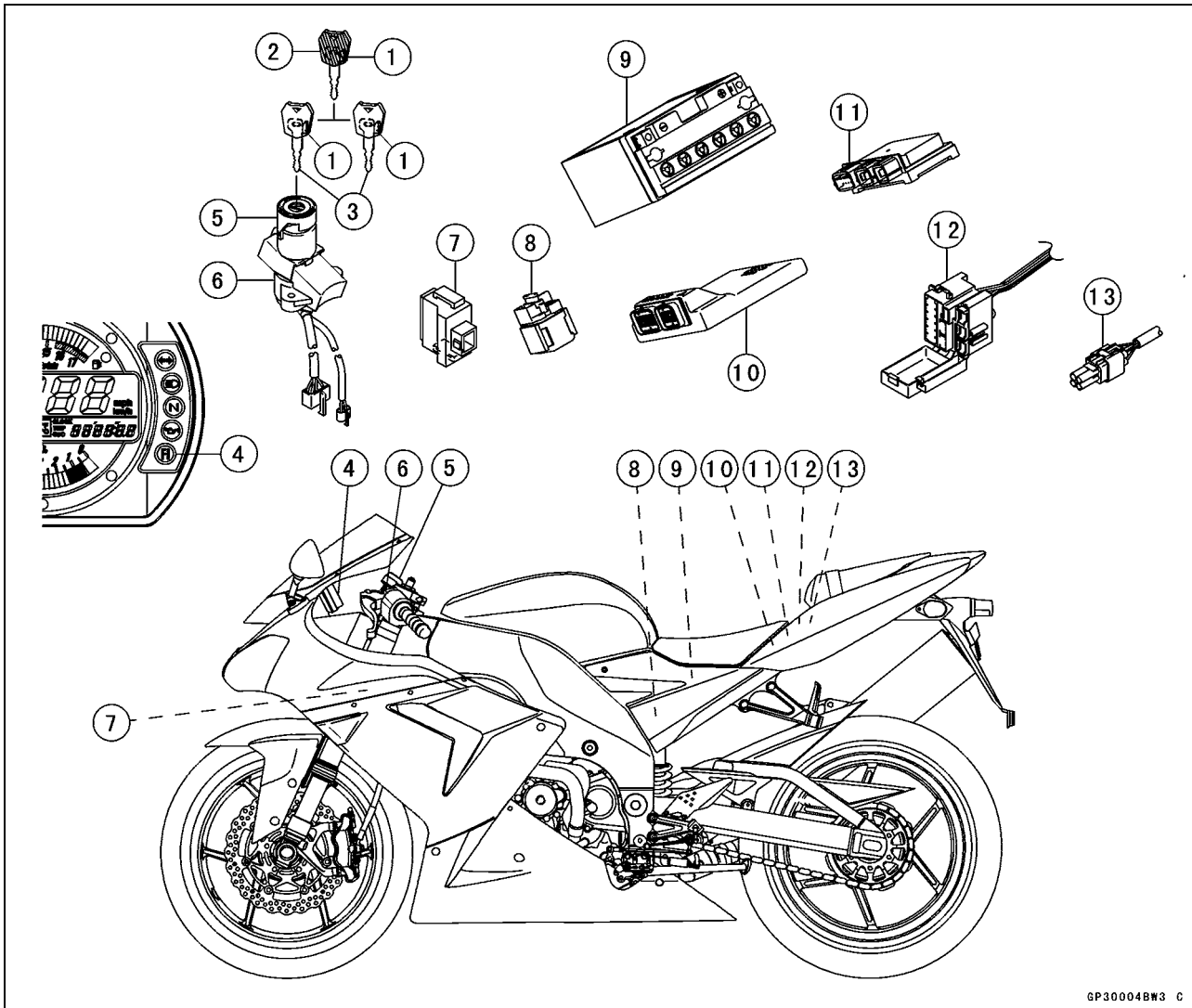

1. Transponder (Inside Keys)
2. Master Key
3. User Keys
4. FI Indicator Light
5. Immobilizer Antenna
6. Ignition Switch
7. Immobilizer Amplifier

8. Starter Relay
9. Battery
10. Electronic Control Unit (ECU)
11. Relay Box
12. Fuse Box
13. Immobilizer/Kawasaki Diagnostic System Connector

### Master Key (1 piece)

The master key (colored red) has an inbuilt transponder, containing a master key code. These codes are unique to each key. This code and an additional two user key codes must be registered in the ECU for the system to operate. The master key is necessary when registering user keys and should not be used as the main key to start the motorcycle except in emergencies (loss or damage of user keys). It should be kept in a safe place.

### Transponder (in Keys)

The transponder (made by Texas Instruments, Inc.) has an integrated circuit with a unique code that also calculates data sent by the ECU. When the ignition switch is turned ON, the transponder is excited by the radio wave transmitted from the antenna and then transmits a unique code to the antenna.

Technical Information-Immobilizer System

**User Key (2 pieces)**

The user keys (colored black) should be used when riding the motorcycle. These keys have unique codes which differ from the master key. Up to a maximum of five user key codes can be stored by the ECU at any one time. These codes can not be registered to the ECU without firstly registering the master key code.

**Antenna**

The antenna transmits a radio wave to excite the transponder, receives the code from the transponder and then transmits the code to the ECU through the amplifier.

**Ignition Switch**

The ignition switch turns the main circuit ON and OFF.

**Amplifier**

The amplifier (which is approximately the same size as a match box), amplifies signals from the antenna and the ECU.

**ECU**

The ECU has the capacity to store a maximum of six key code memories (one master and five user keys). The owner can have a total of five user keys at any one time. The master key memory can not be rewritten after initial registration, whereas the user key memories can be rewritten as necessary. When the ECU communicates with the transponder, a cipher generator changes the code every time it is used to avoid cloning.

**FI Indicator Light**

The condition or the failure of the immobilizer system is indicated by various patterns of the FI indicator light blinking.

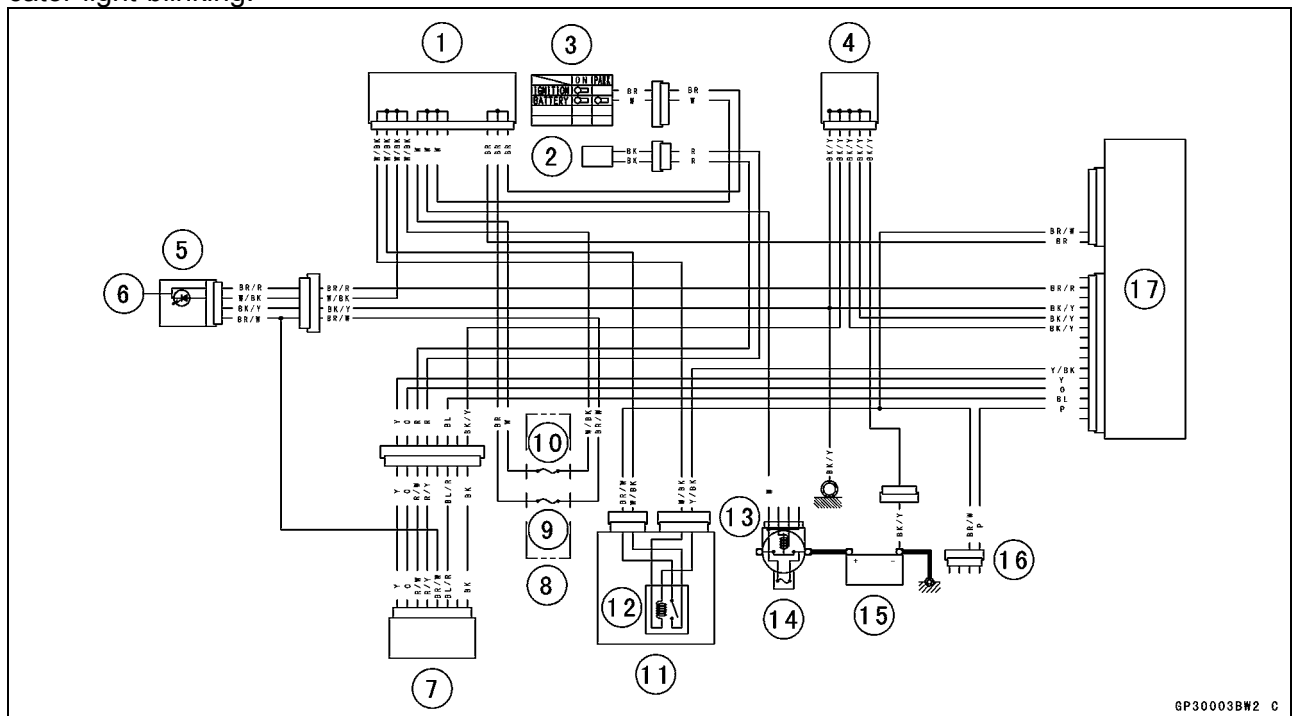

GP30003BW2 C

- |                          |  |
|--------------------------|--|
| 1. Joint Connector 4     | 10. ECU Fuse 15 A                                    |
| 2. Immobilizer Antenna   | 11. Relay Box  |
| 3. Ignition Switch       | 12. ECU Main Relay                                   |
| 4. Joint Connector 2     | 13. Starter Relay                                    |
| 5. Meter Unit            | 14. Main Fuse 30 A                                   |
| 6. FI Indicator Light    | 15. Battery 12 V 10 Ah                               |
| 7. Immobilizer Amplifier | 16. Immobilizer/Kawasaki Diagnostic System Connector |
| 8. Fuse Box              | 17. Electronic Control Unit (ECU)                    |
| 9. Ignition Fuse 10 A    |  |

## 1-14 GENERAL INFORMATION

---

### Technical Information-Immobilizer System

---

#### *Sequence of Operation*

1. Turn ON the ignition switch, the ECU, amplifier and antenna start working, and the meter assembly FI indicator lights up.
2. The transponder excited by radio waves transmitted from the antenna receives the ciphered code from the ECU.
3. The transponder transmits the calculated result from the key's unique code to the ECU.
4. The ECU compares this with its memorized code, and if they match the engine can start. At this time, the FI indicator in the meter assembly is switched off.

**Technical Information-Exhaust Device System****Exhaust Device System**

The exhaust device system consists of the ECU, exhaust butterfly valve, exhaust butterfly valve actuator and exhaust device cables.

Exhaust butterfly valve is installed in the exhaust pipe end. Exhaust butterfly valve actuator is under the seat. The exhaust butterfly valve is operated by the exhaust device cables. Exhaust device system is designed to improve the engine torque at low engine rpms and to reduce the exhaust noise.

Information on RPM, the throttle position, and the gear position sensor is sent to ECU and controlled.

The instruction from ECU is received, exhaust butterfly valve actuator is moved, and exhaust butterfly valve is opened and closed through the cable.

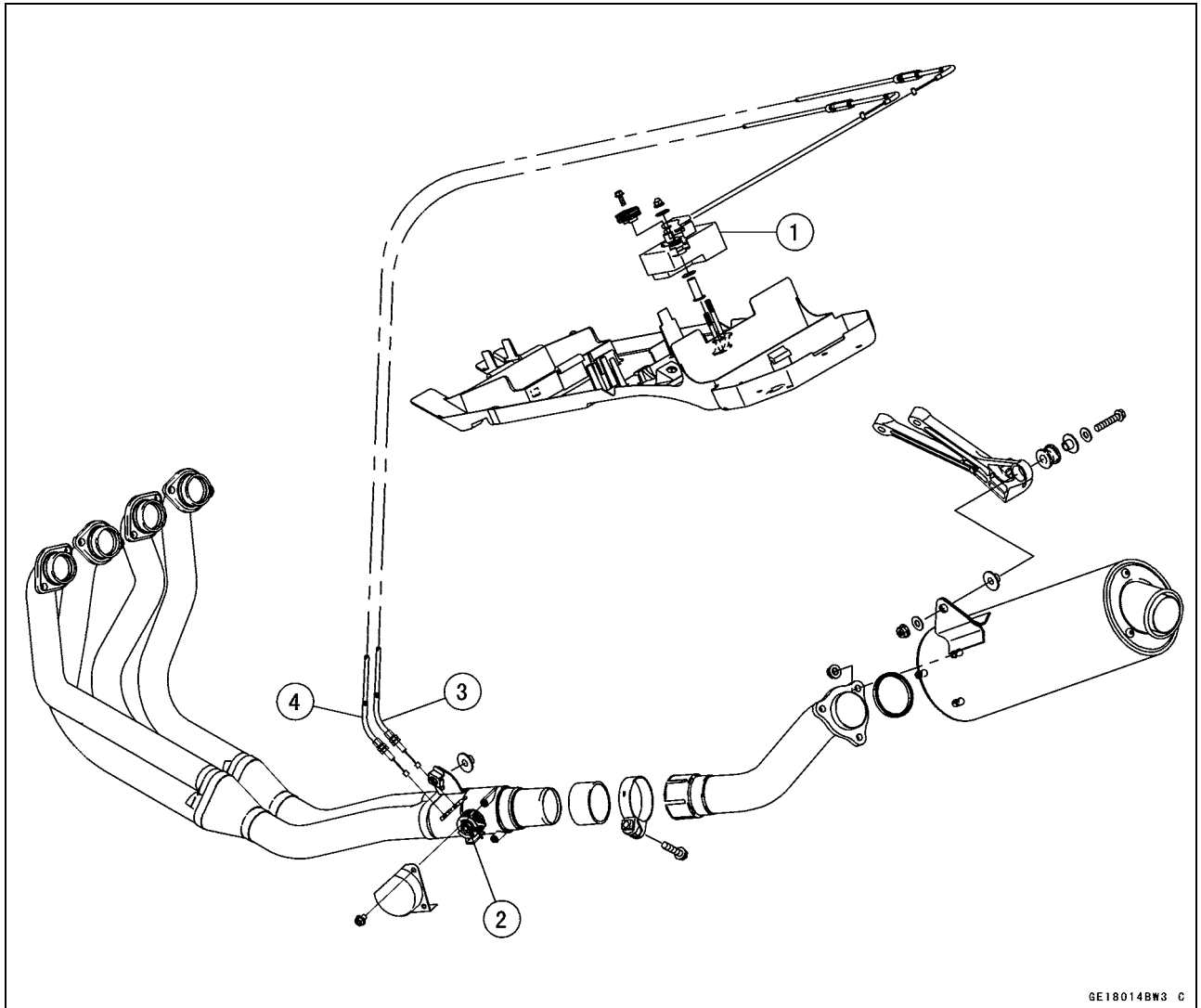

GE18014BW3 C

1. Exhaust Butterfly Valve Actuator
2. Exhaust Butterfly Valve
3. Open Cable (Yellow)
4. Close Cable (Dark Green)

## 1-16 GENERAL INFORMATION

### Technical Information

---

#### *Crankcase Upper*

Crankcase upper and cylinder are a one piece casting, permitting light weight and compact engine.



#### *High-speed Generator*

The high-speed generator is located behind the cylinder, atop the transmission. Although small in diameter it is wider and is driven at twice the crank speed by the clutch to generate ample output at lower rpm.



**Unit Conversion Table**

**Prefixes for Units:**

Prefix	Symbol	Power
mega	M	× 1 000 000
kilo	k	× 1 000
centi	c	× 0.01
milli	m	× 0.001
micro	μ	× 0.000001

**Units of Mass:**

kg	×	2.205	=	lb
g	×	0.03527	=	oz

**Units of Volume:**

L	×	0.2642	=	gal (US)
L	×	0.2200	=	gal (imp)
L	×	1.057	=	qt (US)
L	×	0.8799	=	qt (imp)
L	×	2.113	=	pint (US)
L	×	1.816	=	pint (imp)
mL	×	0.03381	=	oz (US)
mL	×	0.02816	=	oz (imp)
mL	×	0.06102	=	cu in

**Units of Force:**

N	×	0.1020	=	kg
N	×	0.2248	=	lb
kg	×	9.807	=	N
kg	×	2.205	=	lb

**Units of Length:**

km	×	0.6214	=	mile
m	×	3.281	=	ft
mm	×	0.03937	=	in

**Units of Torque:**

N·m	×	0.1020	=	kgf·m
N·m	×	0.7376	=	ft·lb
N·m	×	8.851	=	in·lb
kgf·m	×	9.807	=	N·m
kgf·m	×	7.233	=	ft·lb
kgf·m	×	86.80	=	in·lb

**Units of Pressure:**

kPa	×	0.01020	=	kgf/cm <sup>2</sup>
kPa	×	0.1450	=	psi
kPa	×	0.7501	=	cmHg
kgf/cm <sup>2</sup>	×	98.07	=	kPa
kgf/cm <sup>2</sup>	×	14.22	=	psi
cmHg	×	1.333	=	kPa

**Units of Speed:**

km/h	×	0.6214	=	mph
------	---	--------	---	-----

**Units of Power:**

kW	×	1.360	=	PS
kW	×	1.341	=	HP
PS	×	0.7355	=	kW
PS	×	0.9863	=	HP

**Units of Temperature:**

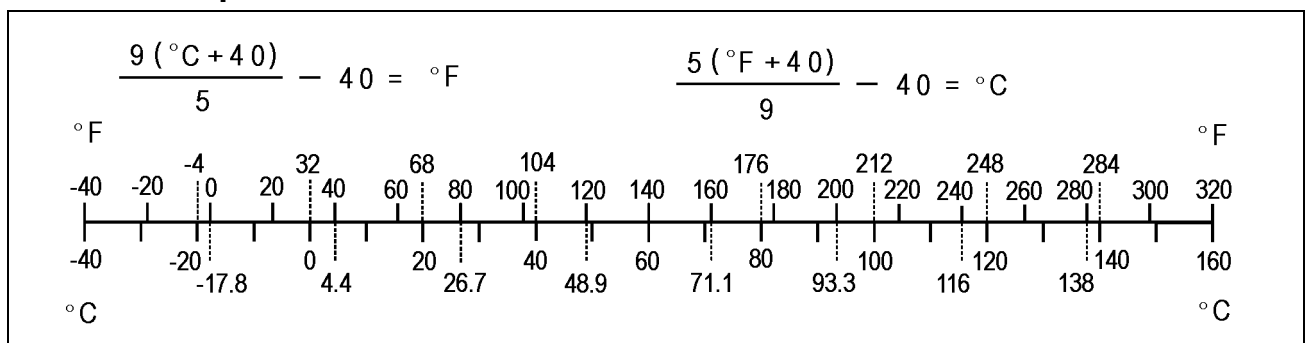





# Periodic Maintenance

## Table of Contents

Periodic Maintenance Chart .....	2-2	Brake Fluid Level Inspection .....	2-32
Torque and Locking Agent .....	2-5	Brake Pad Wear Inspection .....	2-32
Specifications .....	2-11	Brake Light Switch Operation .....	2-33
Special Tools .....	2-13	Suspensions .....	2-34
Maintenance Procedure .....	2-14	Front Forks/Rear Shock Absorber	
Fuel System (DFI) .....	2-14	Operation Inspection .....	2-34
Throttle Cable Inspection .....	2-14	Front Fork Oil Leak Inspection .....	2-34
Engine Vacuum Synchronization		Rear Shock Absorber Oil Leak	
Inspection .....	2-14	Inspection .....	2-34
Idle Speed Inspection .....	2-18	Rocker Arm Operation Inspection	2-34
Fuel Hose and Connection		Tie-rod Operation Inspection .....	2-35
Inspection .....	2-18	Steering System .....	2-35
Cooling System .....	2-19	Steering Play Inspection .....	2-35
Coolant Level Inspection .....	2-19	Steering Stem Bearing	
Radiator Hose and Connection		Lubrication .....	2-36
Inspection .....	2-19	Electrical System .....	2-37
Evaporative Emission Control		Lights and Switches Operation	
System (California Model) .....	2-20	Inspection .....	2-37
Evaporative Emission Control		Headlight Aiming Inspection .....	2-39
System Function Inspection .....	2-20	Side Stand Switch Operation	
Air Suction System .....	2-21	Inspection .....	2-40
Air Suction Valve Inspection .....	2-21	Engine Stop Switch Operation	
Engine Top End .....	2-21	Inspection .....	2-41
Valve Clearance Inspection .....	2-21	Others .....	2-42
Clutch and Drive Train .....	2-25	Chassis Parts Lubrication .....	2-42
Clutch Operation Inspection .....	2-25	Bolts, Nuts and Fasteners	
Drive Chain Lubrication Condition		Tightness Inspection .....	2-43
Inspection .....	2-26	Replacement Parts .....	2-44
Drive Chain Slack Inspection .....	2-27	Fuel Hose Replacement .....	2-44
Drive Chain Wear Inspection .....	2-28	Air Cleaner Element	
Drive Chain Guide Wear		Replacement .....	2-46
Inspection .....	2-29	Coolant Change .....	2-47
Wheels/Tires .....	2-29	Radiator Hose and O-ring	
Tire Air Pressure Inspection .....	2-29	Replacement .....	2-49
Wheel/Tire Damage Inspection .....	2-29	Engine Oil Change .....	2-49
Tire Tread Wear Inspection .....	2-30	Oil Filter Replacement .....	2-50
Wheel Bearing Damage		Brake Hose and Pipe	
Inspection .....	2-30	Replacement .....	2-50
Brake System .....	2-31	Brake Fluid Change .....	2-51
Brake Fluid Leak (Brake Hose		Master Cylinder Rubber Parts	
and Pipe) Inspection .....	2-31	Replacement .....	2-53
Brake Hose Damage and		Caliper Rubber Parts	
Installation Condition		Replacement .....	2-54
Inspection .....	2-31	Spark Plug Replacement .....	2-57
Brake Operation Inspection .....	2-31		



## PERIODIC MAINTENANCE 2-3

### Periodic Maintenance Chart

FREQUENCY	Whichever comes first ↓	* ODOMETER READING × 1000 km (× 1000 mile)							See Page
		1 (0.6)	6 (4)	12 (7.5)	18 (12)	24 (15)	30 (20)	36 (24)	
INSPECTION	Every	•	•	•	•	•	•	•	
Brake light switch operation-inspect		•	•	•	•	•	•	•	2-33
<b>Suspensions</b>									
Front forks/rear shock absorber operation (damping and smooth stroke)-inspect				•		•		•	2-34
Front forks/rear shock absorber oil leak-inspect	year			•		•		•	2-34
Rocker arm operation-inspect				•		•		•	2-34
Tie-rods operation-inspect				•		•		•	2-35
<b>Steering System</b>									
Steering play-inspect	year	•		•		•		•	2-35
Steering stem bearings-lubricate	2 years					•			2-36
<b>Electrical System</b>									
Lights and switches operation-inspect	year			•		•		•	2-37
Headlight aiming-inspect	year			•		•		•	2-39
Side stand switch operation-inspect	year			•		•		•	2-40
Engine stop switch operation-inspect	year			•		•		•	2-41
<b>Others</b>									
Chassis parts-lubricate	year			•		•		•	2-42
Bolts, nuts and fasteners tightness-inspect		•		•		•		•	2-43

#: Service more frequently when operating in severe conditions; dusty, wet, muddy, high speed or frequent starting/stopping.

\*: For higher odometer readings, repeat at the frequency interval established here.

CAL: California Model

## 2-4 PERIODIC MAINTENANCE

### Periodic Maintenance Chart

#### Periodic Replacement Parts

CHANGE/REPLACEMENT	FREQUENCY	* ODOMETER READING						See Page
	Whichever come first ↓	1 (0.6)	12 (7.5)	18 (12)	24 (15)	36 (24)	48 (30)	
Fuel hose	4 years						•	2-44
Air cleaner element #				•		•		2-46
Coolant	3 years					•		2-47
Radiator hose and O-ring	3 years					•		2-49
Engine oil #	year	•	•		•	•	•	2-49
Oil filter	year	•	•		•	•	•	2-50
Brake hose and pipe	4 years						•	2-50
Brake fluid	2 years				•		•	2-51
Master Cylinder/Caliper Rubber Parts	4 years						•	2-53
Spark plug		•	•		•	•	•	2-57

#: Service more frequently when operating in severe conditions; dusty, wet, muddy, high speed or frequent starting/stopping.

\*: For higher odometer readings, repeat at the frequency interval established here.

**Torque and Locking Agent**

The following tables list the tightening torque for the major fasteners requiring use of a non-permanent locking agent or liquid gasket.

Letters used in the “Remarks” column mean:

AL: Tighten the two clamp bolts alternately two times to ensure even tightening torque.

G: Apply grease to the threads.

HL: Apply a heavy duty non-permanent locking agent (Three Bond 1360N).

L: Apply a non-permanent locking agent to the threads.

M: Apply molybdenum disulfide grease.

MO: Apply molybdenum disulfide grease oil (mixture of engine oil and molybdenum disulfide grease in a weight ratio is 10 : 1).

O: Apply oil to the threads and seating surface.

R: Replacement Parts

S: Tighten the fasteners following the specified sequence.

Si: Apply silicone grease (ex. PBC grease).

SS: Apply silicone sealant.

The table below, relating tightening torque to thread diameter, lists the basic torque for the bolts and nuts. Use this table for only the bolts and nuts which do not require a specific torque value. All of the values are for use with dry solvent-cleaned threads.

**Basic Torque for General Fasteners**

Threads diameter (mm)	Torque		
	N·m	kgf·m	ft·lb
5	3.4 ~ 4.9	0.35 ~ 0.50	30 ~ 43 in·lb
6	5.9 ~ 7.8	0.60 ~ 0.80	52 ~ 69 in·lb
8	14 ~19	1.4 ~1.9	10.0 ~ 13.5
10	25 ~ 34	2.6 ~ 3.5	19.0 ~ 25
12	44 ~ 61	4.5 ~ 6.2	33 ~ 45
14	73 ~ 98	7.4 ~ 10.0	54 ~ 72
16	115 ~ 155	11.5 ~ 16.0	83 ~ 115
18	165 ~ 225	17.0 ~ 23.0	125 ~ 165
20	225 ~ 325	23 ~ 33	165 ~ 240

Fastener	Torque			Remarks
	N·m	kgf·m	ft·lb	
<b>Fuel System</b>				
Air Inlet Duct Mounting Bolts	7.0	0.70	62 in·lb	
Air Cleaner Element Cover Screws	1.1	0.11	9.7 in·lb	
Air Cleaner Housing Holder Clamp Screws	4.9	0.50	43 in·lb	
Camshaft Position Sensor Bolt	9.8	1.0	87 in·lb	
Water Temperature Sensor	25	2.5	18	
Vehicle-down Sensor Bolts	6.0	0.60	53 in·lb	
Gear Position Switch Screws	4.9	0.50	43 in·lb	L
Speed Sensor Bolt	4.0	0.40	35 in·lb	L
Crankshaft Sensor Bolts	6.0	0.60	53 in·lb	
Delivery Pipe Mounting Screws	4.9	0.50	43 in·lb	
Throttle Body Assembly Holder Clamp Bolts	2.0	0.20	18 in·lb	
Throttle Body Holder Bolts	9.8	1.0	87 in·lb	
Inlet Air Pressure Sensor Screw	3.5	0.36	31 in·lb	

## 2-6 PERIODIC MAINTENANCE

### Torque and Locking Agent

Fastener	Torque			Remarks
	N·m	kgf·m	ft·lb	
Exhaust Butterfly Valve Actuator Mounting Nuts	7.0	0.70	62 in·lb	L, S
Exhaust Butterfly Valve Actuator Pulley Bolt	4.9	0.50	43 in·lb	
Exhaust Butterfly Valve Cover Bolts	8.8	0.90	78 in·lb	
Fuel Pump Bolts	9.8	1.0	87 in·lb	
Separator Mounting Bolt	11	1.1	97 in·lb	
<b>Cooling System</b>				
Water Hose Clamp Screws	2.0	0.20	17 in·lb	L
Coolant Drain Plug (Water Pump)	9.8	1.0	87 in·lb	
Coolant Drain Plug (Cylinder)	9.8	1.0	87 in·lb	
Coolant Drain Plug (Lower Crankcase)	9.8	1.0	87 in·lb	
Water Pump Cover Bolts	9.8	1.0	87 in·lb	
Oil Cooler Mounting Bolts	20	2.0	14	
Water Passage Plugs	20	2.0	14	
Thermostat Housing Cover Bolts	6.0	0.61	53 in·lb	
Thermostat Housing Mounting Bolts	9.8	1.0	87 in·lb	
Radiator Upper Bolt	7.0	0.70	61 in·lb	
Radiator Lower Bolt	7.0	0.70	61 in·lb	
Radiator Bracket Mounting Bolt	7.0	0.70	61 in·lb	
Coolant Reserve Tank Mounting Screws	9.8	1.0	87 in·lb	
Water Hose Fitting Bolts	9.8	1.0	87 in·lb	
Coolant By-pass Fitting Bolt	8.8	0.90	78 in·lb	
Water Temperature Sensor	25	2.5	18	L
<b>Engine Top End</b>				
Air Suction Valve Cover Bolts	9.8	1.0	87 in·lb	L
Cylinder Head Cover Bolts	9.8	1.0	87 in·lb	
Camshaft Cap Bolts	12	1.2	104 in·lb	S
Camshaft Chain Guide Bolts	12	1.2	104 in·lb	S
Cylinder Head Bolts (M10 New Bolts)	59	6.0	44	MO, S
Cylinder Head Bolts (M10 Used Bolts)	57	5.8	42	MO, S
Cylinder Head Bolts (M6)	12	1.2	104 in·lb	S
Water Passage Plugs	20	2.0	15	L
Throttle Body Holder Bolts	9.8	1.0	87 in·lb	S
Throttle Body Assembly Holder Clamp Bolts	2.0	0.20	17 in·lb	
Camshaft Position Sensor Bolt	9.8	1.0	87 in·lb	
Front Camshaft Chain Guide Bolt (Upper)	25	2.5	18	
Front Camshaft Chain Guide Bolt (Lower)	12	1.2	104 in·lb	
Camshaft Chain Tensioner Mounting Bolts	9.8	1.0	87 in·lb	
Camshaft Chain Tensioner Cap Bolt	20	2.0	15	
Spark Plugs	13	1.3	113 in·lb	
Cam Sprocket Mounting Bolts	15	1.5	11	L
Coolant Drain Plug (Cylinder)	9.8	1.0	87 in·lb	
Exhaust Pipe Manifold Holder Nuts	17	1.7	12	
Muffler Body Clamp Bolt	17	1.7	12	

## PERIODIC MAINTENANCE 2-7

### Torque and Locking Agent

Fastener	Torque			Remarks
	N·m	kgf·m	ft·lb	
Muffler Body Mounting Bolts	25	2.5	18	
Crankshaft Sensor Cover Bolts	9.8	1.0	87 in·lb	L
Muffler Body Assembly Nuts	22	2.2	16	
Exhaust Butterfly Valve Cable Locknuts	7.0	0.71	62 in·lb	
Exhaust Butterfly Valve Cover Bolts	9.0	0.90	80 in·lb	
Exhaust Butterfly Valve Cable Adjuster Locknuts	7.0	0.71	62 in·lb	
Bracket Mounting Bolts	9.8	1.0	87 in·lb	
<b>Clutch</b>				
Clutch Lever Clamp Bolts	7.8	0.80	69 in·lb	S
Clutch Cover Mounting Bolts (M6, L = 40 mm)	9.8	1.0	87 in·lb	S
Clutch Cover Mounting Bolt (M6, L = 30 mm)	9.8	1.0	87 in·lb	S
Clutch Cover Mounting Bolts (M6, L = 25 mm)	9.8	1.0	87 in·lb	S
Oil Filler Plug	2.0	0.20	18 in·lb	
Clutch Spring Bolts	9.8	1.0	87 in·lb	
Clutch Hub Nut	130	13.3	96	R
Sub Clutch Hub Bolts	11	1.1	95 in·lb	L
<b>Engine Lubrication System</b>				
Engine Oil Drain Bolt	20	2.0	14	
Oil Filter	31	3.2	23	G, R
Holder Mounting Bolt	35	3.6	26	L
Oil Pan Bolt (M6, L = 85 mm)	9.8	1.0	87 in·lb	
Oil Pan Bolts (M6, L = 25 mm)	9.8	1.0	87 in·lb	
Oil Pressure Relief Valve	15	1.5	11	L
Oil Pressure Switch	15	1.5	11	SS
Oil Pressure Switch Terminal Bolt	1.5	0.15	13 in·lb	
Sub Oil Pan Bolts	25	2.5	18	
Oil Filter Case Mounting Bolts	20	2.0	14	L
Oil Passage Plugs	20	2.0	14	L
Oil Pump Cover Bolts	9.8	1.0	87 in·lb	
Oil Pump Drive Gear Bolts	9.8	1.0	87 in·lb	
Oil Cooler Mounting Bolts	20	2.0	14	
<b>Engine Removal/Installation</b>				
Adjusting Collar Locknut	49	5.0	36	S
Upper Bracket Bolts	44	4.5	33	S
Upper Bracket Bolts	25	2.5	18	S
Engine Bracket Bolts	44	4.5	33	S
Middle Engine Mounting Nut	44	4.5	33	S
Lower Engine Mounting Nut	44	4.5	33	S
Engine Mounting Adjusting Bolt	9.8	1.0	87 in·lb	M, S
Front Engine Mounting Bolts	44	4.5	33	S
Middle Engine Mounting Bolt	9.8	1.0	87 in·lb	S
Lower Engine Mounting Bolt	9.8	1.0	87 in·lb	S

## 2-8 PERIODIC MAINTENANCE

### Torque and Locking Agent

Fastener	Torque			Remarks
	N·m	kgf·m	ft·lb	
<b>Crankshaft/Transmission</b>				
Breather Plate Bolts	9.8	1.0	87 in·lb	L
Crankcase Bolts (M9)	46	4.7	34	MO, S
Crankcase Bolts (M8, L = 90 mm)	27	2.8	20	S
Crankcase Bolt (M8, L = 45 mm)	27	2.8	20	S
Crankcase Bolt (M7, L = 85 mm)	25	2.5	18	S
Crankcase Bolt (M7, L = 50 mm)	25	2.5	18	S
Crankcase Bolts (M7, L = 45 mm)	25	2.5	18	S
Crankcase Bolts (M7, L = 32 mm)	25	2.5	18	S
Crankcase Bolts (M6, L = 40 mm)	12	1.2	104 in·lb	S
Crankcase Bolt (M6, L = 22 mm)	12	1.2	104 in·lb	S
Shift Drum Bearing Holder Screws	5.0	0.51	44 in·lb	L
Shift Fork Holder Bolt	12	1.2	104 in·lb	L
Connecting Rod Big End Nuts	see the text	←	←	←
Timing Rotor Bolt	40	4.1	30	
Oil Pressure Switch	15	1.5	11	SS
Oil Pressure Switch Terminal Bolt	1.5	0.15	13 in·lb	
Oil Passage Plugs	20	2.0	14	L
Plate Screw	5.0	0.51	44 in·lb	L
Bearing Position Plate Screws	5.0	0.51	44 in·lb	L
Drive Shaft Cover Bolts	25	2.5	18	
Plugs	17	1.7	13	
Coolant Drain Plug (Lower Crankcase)	9.8	1.0	87 in·lb	
Plug	15	1.5	11	
Shift Pedal Mounting Bolt	25	2.5	18	
Gear Positioning Lever Bolt	12	1.2	104 in·lb	
Shift Shaft Return Spring Pin	29	3.0	22	L
Shift Drum Cam Holder Bolt	12	1.2	104 in·lb	L
Shift Lever Bolt	7.0	0.71	62 in·lb	
Tie-rod Locknuts	7.0	0.71	62 in·lb	
Gear Position Switch Screws	5.0	0.51	44 in·lb	L
<b>Wheels/Tires</b>				
Front Axle Clamp Bolts	20	2.0	14.5	AL
Front Axle Nut	108	11	81	
Rear Axle Nut	108	11	81	
<b>Final Drive</b>				
Engine Sprocket Nut	127	13	94	MO
Engine Sprocket Cover Bolts	9.8	1.0	87 in·lb	
Chain Guide Bolts	9.8	1.0	87 in·lb	
Speed Sensor Bolt	4.0	0.40	35 in·lb	L
Rear Sprocket Nuts	59	6.0	43	
Rear Sprocket Studs	–	–	–	L



**PERIODIC MAINTENANCE 2-9**

**Torque and Locking Agent**

Fastener	Torque			Remarks
	N·m	kgf·m	ft·lb	
<b>Brakes</b>				
Bleed Valves	7.8	0.80	69 in·lb	
Brake Hose Banjo Bolts	25	2.5	18	
Brake Lever Pivot Bolt	1.0	0.10	9 in·lb	Si
Brake Lever Pivot Bolt Locknut	6.0	0.61	53 in·lb	
Front Brake Reservoir Cap Stopper Screw	1.2	0.12	11 in·lb	
Front Brake Light Switch Screw	1.2	0.12	11 in·lb	
Brake Pedal Bolt	8.8	0.90	78 in·lb	
Front Master Cylinder Clamp Bolts	8.8	0.90	78 in·lb	S
Front Caliper Mounting Bolts	34	3.5	25	
Front Caliper Assembly Bolts	22	2.2	16	
Brake Disc Mounting Bolts	27	2.8	20	L
Rear Caliper Mounting Bolts	25	2.5	18	
Rear Master Cylinder Mounting Bolts	25	2.5	18	
Rear Master Cylinder Push Rod Locknut	18	1.8	13	
Front Brake Pad Pins	15	1.5	11	
Right Foot Guard Bolts	25	2.5	18	
<b>Suspension</b>				
Front Fork Clamp Bolts (Upper)	20	2.0	14.5	
Front Fork Clamp Bolts (Lower)	30	3.0	22	AL
Front Fork Top Plugs	23	2.3	17	
Piston Rod Nut	15	1.5	11	
Front Fork Bottom Allen Bolts	23	2.3	17	L
Front Axle Clamp Bolts	20	2.0	14.5	AL
Rear Shock Absorber Nuts	34	3.5	25	
Rear Shock Absorber Bracket Nut	59	6.0	43	
Swingarm Pivot Shaft Nut	108	11	81	
Uni-track Rocker Arm Nut	34	3.5	25	
Tie-rod Nuts	59	6.0	43	
Swingarm Pivot Adjusting Collar	20	2.0	14	
Swingarm Pivot Adjusting Collar Locknut	98	10	72	
<b>Steering</b>				
Steering Stem Head Nut	78	8.0	58	
Steering Stem Nut	20	2.0	14.5	
Handlebar Bolts	25	2.5	18	
Handlebar Position Bolts	9.8	1.0	87 in·lb	L
Handlebar Weight Screws	29	3.0	22	O
Handlebar Switch Housing Screws	3.5	0.36	31 in·lb	
<b>Frame</b>				
Side Stand Bolt	44	4.5	32	G
Footpeg Stay Bolts	25	2.5	18	
Side Stand Bracket Bolts	49	5.0	36	L
Rear Frame Bolts	44	4.5	32	

## 2-10 PERIODIC MAINTENANCE

### Torque and Locking Agent

Fastener	Torque			Remarks
	N·m	kgf·m	ft·lb	
Side Stand Switch Bolt	8.8	0.90	78 in·lb	L
Wind Shield Mounting Screws	0.40	0.04	3.5 in·lb	
Front Fender Mounting Bolts	3.9	0.40	35 in·lb	
Inner Fender Mounting Bolts	2.5	0.25	1.8 in·lb	
<b>Electrical System</b>				
Alternator Shaft Lever Bolt	25	2.5	18	L
Alternator Shaft Spring Bolt	9.8	1.0	87 in·lb	
Alternator Shaft Clamp Bolt	12	1.2	104 in·lb	
Spark Plugs	13	1.3	113 in·lb	
Stator Coil Bolts	8.0	0.80	71 in·lb	HL
Alternator Lead Holding Plate Bolts	6.0	0.60	52 in·lb	
Alternator Cover Bolts	25	2.5	18	
Crankshaft Sensor Cover Bolts	9.8	1.0	87 in·lb	L
Crankshaft Sensor Bolts	6.0	0.60	52 in·lb	
Timing Rotor Bolt	40	4.0	29	
Starter Motor Mounting Bolts	9.8	1.0	87 in·lb	
Starter Motor Through Bolts	3.5	0.36	31 in·lb	
Starter Motor Lead Terminal Nut	6.0	0.61	53 in·lb	
Starter Motor Lead Mounting Bolt	4.0	0.41	35 in·lb	
Battery Lead Mounting Bolt	4.0	0.41	35 in·lb	
Front Brake Light Switch Screws	1.2	0.12	11 in·lb	
Switch Housing	1.2	0.12	11 in·lb	
Gear Position Switch Screws	4.9	0.50	43 in·lb	L
Water Temperature Sensor	25	2.5	18	
License Plate Light Mounting Screws	1.2	0.12	11 in·lb	
Camshaft Position Sensor Bolt	9.8	1.0	87 in·lb	
Starter Clutch Bolts	50	5.0	36	Lh
Starter Clutch Cover Bolts	9.8	1.0	87 in·lb	
Idle Gear Cover Bolts	9.8	1.0	87 in·lb	
Meter Mounting Screws	1.2	0.12	11 in·lb	
Headlight Mounting Screws	1.2	0.12	11 in·lb	
Front Turn Signal Light Mounting Screws	1.2	0.12	11 in·lb	
Regulator/rectifier Bolts	9.8	1.0	87 in·lb	

**Specifications**

Item	Standard	Service Limit
<b>Fuel System</b>		
Throttle Grip Free Play	2 ~ 3 mm (0.08 ~ 0.12 in.)	---
Idle Speed	1 100 ±50 r/min (rpm)	---
Throttle Body Vacuum	30 ±1.3 kPa (225 ±10 mmHg) at idle speed	---
Air Cleaner Element	Viscous paper element	---
<b>Cooling System</b>		
Coolant:		
Type (Recommended)	Permanent type antifreeze	---
Color	Green	---
Mixed Ratio	Soft water 50%, coolant 50%	---
Freezing Point	-35°C (-31°F)	---
Total Amount	2.5 L (2.6 US qt)	---
<b>Engine Top End</b>		
Valve Clearance:		
Exhaust	0.17 ~ 0.22 mm (0.0067 ~ 0.0087 in.)	---
Inlet	0.15 ~ 0.24 mm (0.0059 ~ 0.0094 in.)	---
<b>Clutch</b>		
Clutch Lever Free Play	2 ~ 3 mm (0.08 ~ 0.12 in.)	---
<b>Engine Lubrication System</b>		
Engine Oil:		
Type	API SE, SF or SG API SH or SJ with JASO MA	---
Viscosity	SAE 10W-40	---
Capacity	2.7 L (2.9 US qt) (when filter is not removed)	---
	3.0 L (3.2 US qt) (when filter is removed)	---
	3.7 L (3.9 US qt) (when engine is completely dry)	---
Level	Between upper and lower level lines (Wait 2 ~ 3 minutes after idling or running)	---
<b>Tires</b>		
Tread Depth:		
Front	DUNLOP: 4.0 mm (0.16 in.)	1 mm (0.04 in.), (DE, AT, CH) 1.6 mm (0.06 in.)
Rear	DUNLOP: 5.5 mm (0.22 in.)	Up to 130 km/h (80 mph): 2 mm (0.08 in.), Over 130 km/h (80 mph): 3 mm (0.12 in.)
Air Pressure (when Cold):		
Front	Up to 180 kg (397 lb) load: 250 kPa (2.5 kgf/cm <sup>2</sup> , 36 psi)	---
Rear	Up to 180 kg (397 lb) load: 290 kPa (2.9 kgf/cm <sup>2</sup> , 42 psi)	---

## 2-12 PERIODIC MAINTENANCE

### Specifications

Item	Standard	Service Limit
<b>Final Drive</b>		
Drive Chain Slack	35 ~ 45 mm (1.4 ~ 1.8 in.)	---
Drive Chain Wear (20-link Length)	317.5 ~ 318.2 mm (12.50 ~ 12.53 in.)	323 mm (12.7 in.)
Standard Chain:		
Make	RK EXCEL	---
Type	RK 525MFO	---
Link	110 links	---
<b>Brakes</b>		
Brake Fluid:		
Grade	DOT4	---
Brake Pad Lining Thickness:		
Front	4 mm (0.16 in.)	1 mm (0.04 in.)
Rear	5 mm (0.20 in.)	1 mm (0.04 in.)
Brake Light Timing:		
Front	Pulled ON	---
Rear	On after about 10 mm (0.39 in.) of pedal travel	---
<b>Electrical System</b>		
Spark Plug Gap	0.8 ~ 0.9 mm (0.032 ~ 0.035 in.)	---

AT: Austria

CH: Switzerland

DE: Germany

US: United States

**Special Tools**

**Inside Circlip Pliers:**  
57001-143

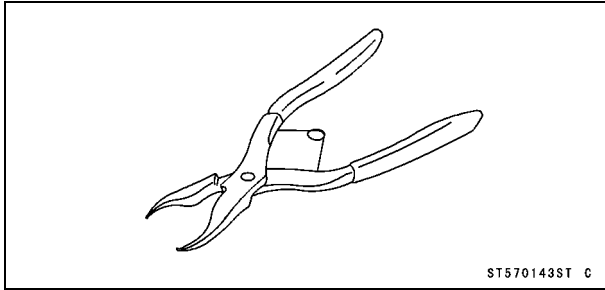

**Lead Wire - Peak Voltage Adapter:**  
57001-1449

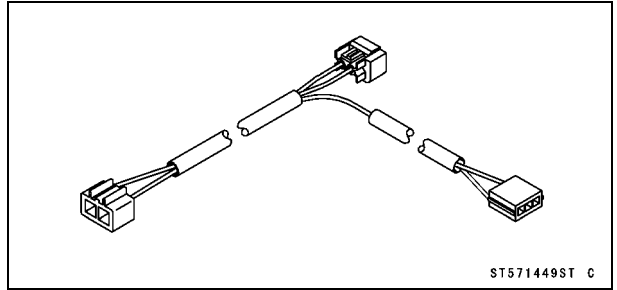

**Steering Stem Nut Wrench:**  
57001-1100

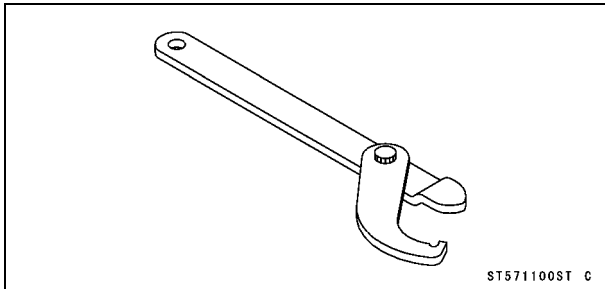

**Extension Tube:**  
57001-1578

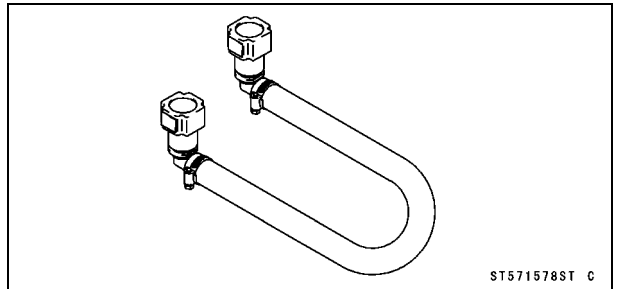

**Jack:**  
57001-1238

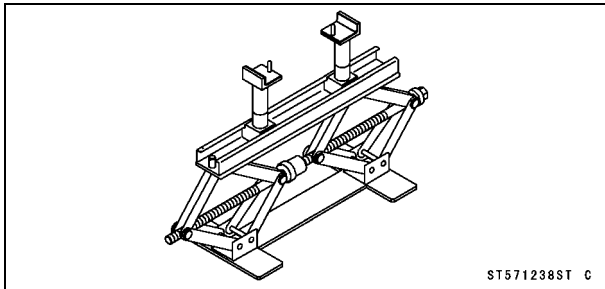

**Pilot Screw Adjuster, D:**  
57001-1588

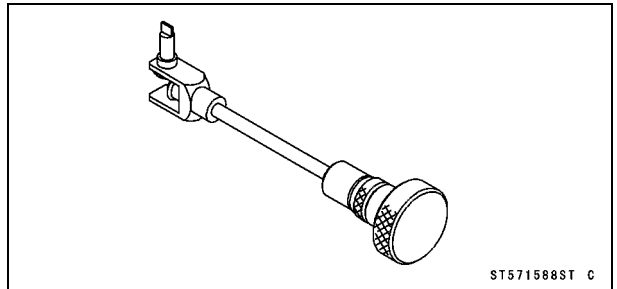

**Oil Filter Wrench:**  
57001-1249

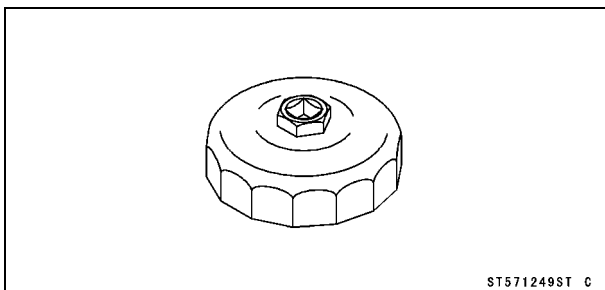

## 2-14 PERIODIC MAINTENANCE

### Maintenance Procedure

#### Fuel System (DFI)

##### Throttle Cable Inspection

##### Throttle Grip Free Play Inspection

- Check the throttle grip free play [A].
- ★ If the free play is incorrect, adjust the throttle cables.

##### Throttle Grip Free Play

**Standard:** 2 ~ 3 mm (0.08 ~ 0.12 in.)

- Check that the throttle grip [B] moves smoothly from full open to close, and the throttle closes quickly and completely by the return spring in all steering positions.
- ★ If the throttle grip does not return properly, check the throttle cables routing, grip free play, and cable damage. Then lubricate the throttle cable.
- Run the engine at the idle speed, and turn the handlebar all the way to the right and left to ensure that the idle speed does not change.
- ★ If the idle speed increases, check the throttle cable free play and the cable routing.

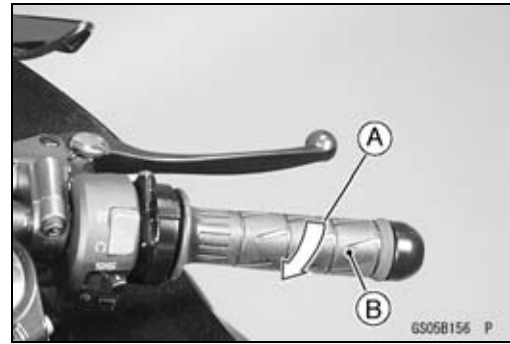

##### Throttle Grip Free Play Adjustment

- Loosen the locknut [A].
- Screw accelerator cable adjuster [B] to give the throttle grip plenty of play.
- Turn the accelerator cable adjuster until 2 ~ 3 mm (0.08 ~ 0.12 in.) of throttle grip play is obtained.
- Tighten the locknut.
- ★ If necessary, adjust the decelerator cable as follows:
- Remove:
  - Air Cleaner Housing (see Fuel System (DFI) chapter)
- Loosen the locknut [A].
- Screw decelerator cable adjuster [B] to give the throttle grip plenty of play.
- Turn the decelerator cable adjuster until 2 ~ 3 mm (0.08 ~ 0.12 in.) of throttle grip play is obtained.
- Tighten the locknut.

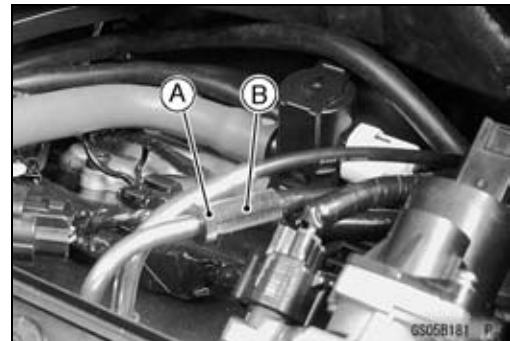
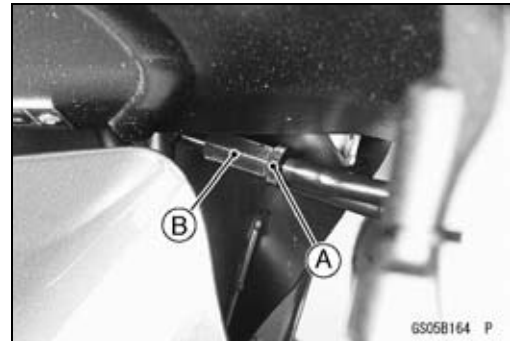

##### Engine Vacuum Synchronization Inspection

#### NOTE

○ These procedures are explained on the assumption that the inlet and exhaust systems of the engine are in good condition.

- Situate the motorcycle so that it is vertical.
- Remove:
  - Air Cleaner Housing (see Fuel System (DFI) chapter)
- Pull off the rubber caps [A] from the fittings of each throttle body.
- For California model, pull off the vacuum hose and return hose.

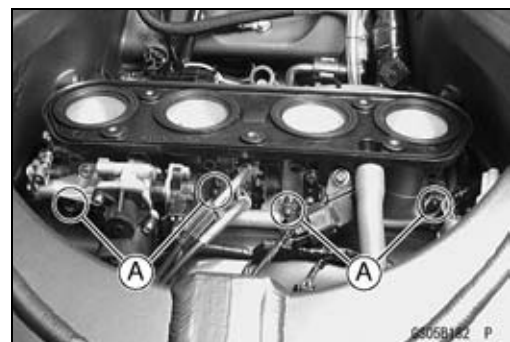

**Maintenance Procedure**

- Plug the engine breather hose end [A].

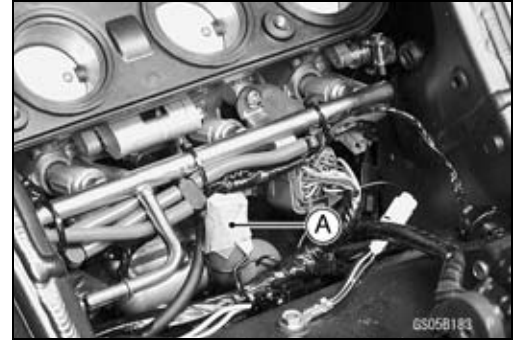

- Connect a commercially available vacuum gauge and hoses [A] to the fittings on the throttle body.
- Connect a highly accurate tachometer to one of the stick coil primary leads using the adapter [B].

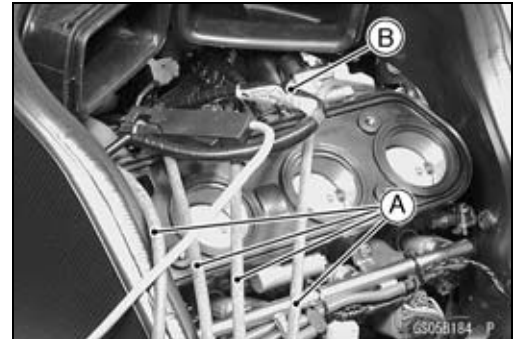

**Special Tool - Lead Wire-Peak Voltage Adapter: 57001-1449**

- Install:
  - Tachometer [A]
  - Vacuum Gauge [B]
- Connect:
  - Fuel Pump Lead Connector
  - Extension Tube [C]

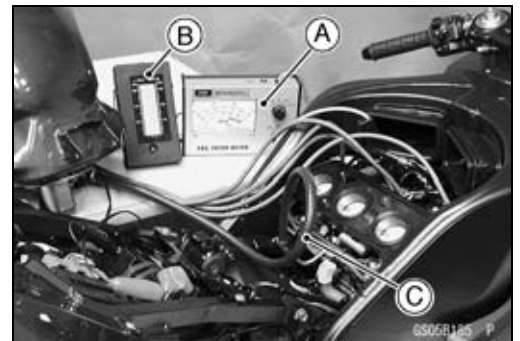

**Special Tool - Extension Tube: 57001-1578**

- Start the engine and warm it up thoroughly.
- Check the idle speed.
- ★ If the idle speed is out of the specified range, adjust it with the adjust screw.

**CAUTION**

**Do not measure the idle speed by the tachometer of the meter unit.**

- While idling the engine, inspect the throttle body vacuum, using the vacuum gauge.

**Throttle Body Vacuum**

**Standard:     30 ±1.3 kPa (225 ±10 mmHg) at Idle Speed**  
**1 100 ±50 r/min (rpm)**

## 2-16 PERIODIC MAINTENANCE

### Maintenance Procedure

★ If any vacuum is not within specifications, first synchronize the balance of the left (#1, #2 throttle valves) and right (#3, #4 throttle valves) assemblies.

**Example:**

- #1: 210 mmHg
- #2: 240 mmHg
- #3: 200 mmHg
- #4: 220 mmHg

- With the engine at the correct idle speed, equalize higher vacuum of #1 or #2 (for example 240 mmHg) to higher vacuum of #3 or #4 (for example 220 mmHg) by turning the center adjusting screw [A].

#### NOTE

○ After adjustment, the final vacuum measurement between the highest throttle valves may not be 240 mmHg (for example). The goal is to have the highest two vacuums between the left (1 and 2) and right (3 and 4) banks be the same and be within the service limits.

- Open and close the throttle after each measurement, and adjust the idle speed as necessary.
- Once the throttle valves have been synchronized, inspect output voltage of the main throttle sensors to ensure proper operation (procedure is explained at the end of this section).

★ If a value of measured vacuum pressure is out of the specified range after synchronization, adjust the bypass screws [A].

**Special Tool - Pilot Screw Adjuster, D: 57001-1588**

- Adjust lower vacuum between #1 and #2 to higher vacuum of #1 and #2.
- Adjust the lower vacuum between #3 and #4 to higher vacuum of #3 and #4.
- Open and close the throttle valves after each measurement, and adjust the idle speed as necessary.
- Check the vacuums as before.
- ★ If all vacuums are within the specification range, finish the engine vacuum synchronization.
- ★ If any vacuum cannot be adjusted within the specification, remove the bypass screws #1 ~ #4 and clean them.

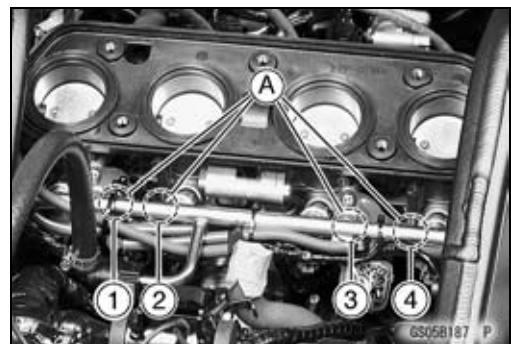



**Maintenance Procedure**

- Turn in the bypass screw [A] with counting the number of turns until it seals fully but not tightly. Record the number of turns.

**Torque - Bypass Screw: 0.2 N·m (0.02 kgf·m, 1.7 in·lb)**

**CAUTION**

**Do not over tighten them. They could be damaged, requiring replacement.**

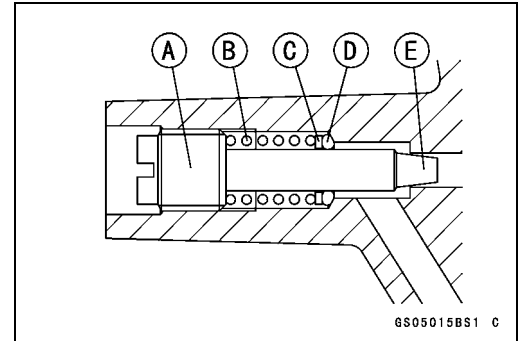

- Remove:
  - Bypass Screw
  - Spring [B]
  - Washer [C]
  - O-ring [D]
- Check the bypass screw and its hole for carbon deposits.
- ★ If any carbons accumulate, wipe the carbons off from the bypass screw and the hole, using a cotton pad penetrated with a high-flash point solvent.
- Replace the O-ring with a new one.
- Check the tapered portion [E] of the bypass screw for wear or damage.
- ★ If the bypass screw is worn or damaged, replace it.
- Turn in the bypass screw until it seats fully but not tightly.

**Torque - Bypass Screw: 0.2 N·m (0.02 kgf·m, 1.7 in·lb)**

- Back out the same number of turns counted when first turned in. This is to set the screw to its original position.

**NOTE**

○ A throttle body has different “turns out” of the bypass screw for each individual unit. On setting the bypass screw, use the “turns out” determined during disassembly.

- Repeat the same procedure for other bypass screws.
- Repeat the synchronization.
- ★ If the vacuums are correct, check the output voltage of the main throttle sensor (see Output Voltage Inspection of Main Throttle Sensor in the Fuel System (DFI) chapter).

**Main Throttle Sensor Output Voltage**

**Connections to ECU**

**Meter (+) → Y/W lead (terminal 5)**

**Meter (–) → BR/BK lead (terminal 59)**

**Standard:**

**0.66 ~ 0.68 V DC (at idle throttle opening)**

- ★ If the output voltage is out of the range, check the throttle input voltage (see Input Voltage Inspection of Main Throttle Sensor in the Fuel System (DFI) chapter).
- Remove the vacuum gauge hoses and install the rubber caps on the original position.

## 2-18 PERIODIC MAINTENANCE

### Maintenance Procedure

#### Idle Speed Inspection

##### Idle Speed Inspection

- Start the engine and warm it up thoroughly.
- With the engine idling, turn the handlebar to both sides [A].
- ★ If handlebar movement changes the idle speed, the throttle cables may be improperly adjusted or incorrectly routed, or damaged. Be sure to correct any of these conditions before riding (see Cable, Wire, and Hose Routing section in Appendix chapter).



#### **⚠ WARNING**

Operation with improperly adjusted, incorrectly routed, or damaged cables could result in an unsafe riding condition.

- Check the idle speed.
- ★ If the idle speed is out of specified range, adjust it.

#### Idle Speed

Standard: 1 100 ±50 r/min (rpm)

#### Idle Speed Adjustment

- Start the engine and warm it up thoroughly.
- Turn the adjusting screw [A] until the idle speed is correct.
- Open and close the throttle a few times to make sure that the idle speed is within the specified range. Readjust if necessary.



#### Fuel Hose and Connection Inspection

##### Fuel Hose and Pipe Leak, Damage Inspection

- The fuel hose [A] is designed to be used throughout the motorcycle's life without any maintenance. However, if the motorcycle is not properly handled, the high pressure inside the fuel line can cause fuel to leak or the hose to burst.
- Remove the fuel tank (see Fuel System (DFI) chapter) and check the fuel hose.
- ★ Replace the fuel hose if any fraying, cracks [B] or bulges [C] are noticed.

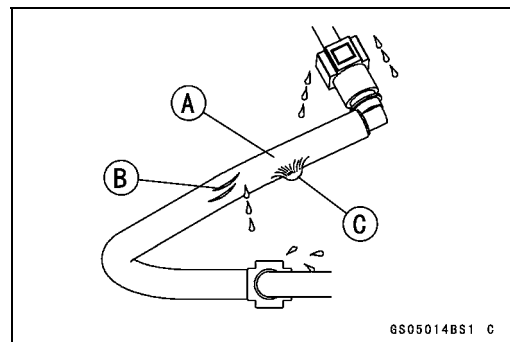

##### Fuel Hose and Pipe Installation Condition Inspection

- Check that the hose joints are securely connected.
- When installing the fuel hose, avoid sharp bending, kinking, flattening or twisting.
- ★ Replace the hose if it has been sharply bent or kinked.

**Maintenance Procedure**

**Cooling System**

*Coolant Level Inspection*

**NOTE**

○ Check the level when the engine is cold (room or ambient temperature).

- Check the coolant level in the reserve tank [A] with the motorcycle held perpendicular (Do not use the sidestand).
- ★ If the coolant level is lower than the “L” level line [B], unscrew the reserve tank cap and add coolant to the “F” level line [C].

“L”: low

“F”: full

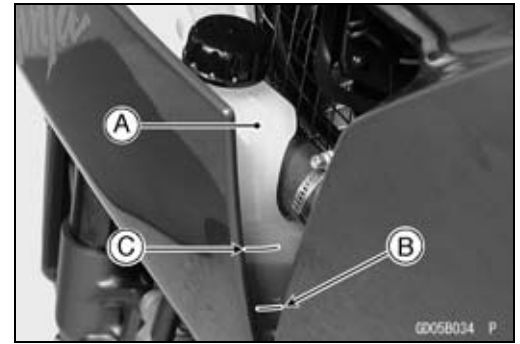

**CAUTION**

For refilling, add the specified mixture of coolant and soft water. Adding water alone dilutes the coolant and degrades its anticorrosion properties. The diluted coolant can attack the aluminum engine parts. In an emergency, soft water alone can be added. But the diluted coolant must be returned to the correct mixture ratio within a few days. If coolant must be added often or the reservoir tank has run completely dry, there is probably leakage in the cooling system. Check the system for leaks. Coolant ruins painted surfaces. Immediately wash away any coolant that spills on the frame, engine, wheels or other painted parts.

*Radiator Hose and Connection Inspection*

**Coolant Leak and Radiator Hose Damage Inspection**

- The high pressure inside the radiator hose can cause coolant to leak [A] or the hose to burst if the line is not properly maintained.
- Visually inspect the hoses for signs of deterioration. Squeeze the hoses. A hose should not be hard and brittle, nor should it be soft or swollen.
- ★ Replace the hose if any fraying, cracks [B] or bulges [C] are noticed.

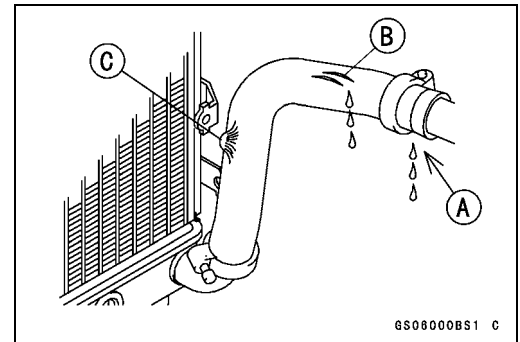

**Radiator Hose Installation Condition Inspection**

- Check that the hoses are securely connected and clamps are tightened correctly.

**Torque - Radiator Hose Clamp Screws: 2.0 N·m (0.20 kgf·m, 17 in·lb)**

## 2-20 PERIODIC MAINTENANCE

### Maintenance Procedure

#### Evaporative Emission Control System (California Model)

##### Evaporative Emission Control System Function Inspection

- Inspect the canister as follow:
  - Remove:
    - Right Lower Fairing (see Frame chapter)
    - Right Middle Fairing (see Frame chapter)
  - Remove the canister [A], and disconnect the hoses from the canister.
  - Visually inspect the canister for cracks or other damage.
  - ★ If the canister has any cracks or bad damage, replace it with a new one.

#### NOTE

○ *The canister is designed to work well through the motorcycle's life without any maintenance if it is used under normal conditions.*

- Check the liquid/vapor separator as follows:
  - Remove:
    - Right Middle Fairing (see Frame chapter)
  - Disconnect the hoses from the separator, and remove the separator [A] from the motorcycle right side.
  - Visually inspect the separator for cracks and other damage.
  - ★ If the separator has any cracks or damage, replace it with a new one.
  - To prevent the gasoline from flowing into or out of the canister, hold the separator perpendicular to the ground.
- Check the hoses of the evaporative emission control system as follows:
  - Check that the hoses are securely connected and clips are in position.
  - Replace any kinked, deteriorated or damaged hoses.
  - Route the hoses according to Cable, Wire, and Hose Routing section in the Appendix chapter. Refer to the diagram of the evaporative emission control system in the Fuel System (DFI) chapter too.
  - When installing the hoses, avoid sharp bending, kinking, flattening or twisting, and route the hoses with a minimum of bending so that the emission flow will not be obstructed.

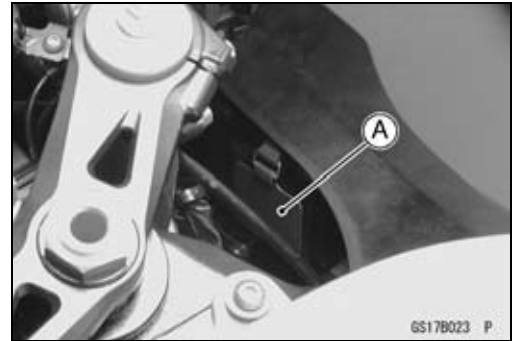

**Maintenance Procedure**

**Air Suction System**

*Air Suction Valve Inspection*

- Remove the air suction valve (see Engine Top End chapter).
- Visually inspect the reeds [A] for cracks, folds, warps, heat damage, or other damage.
- ★ If there is any doubt as to the condition of the reed, replace the air suction valve as an assembly.
- Check the reed contact areas [B] of the valve holder for grooves, scratches, any signs of separation from the holder, or heat damage.
- ★ If there is any doubt as to the condition of the reed contact areas, replace the air suction valve as an assembly.
- If any carbon or other foreign particles have accumulated between the reed and the reed contact area, wash the valve assembly with a high flash-point solvent.

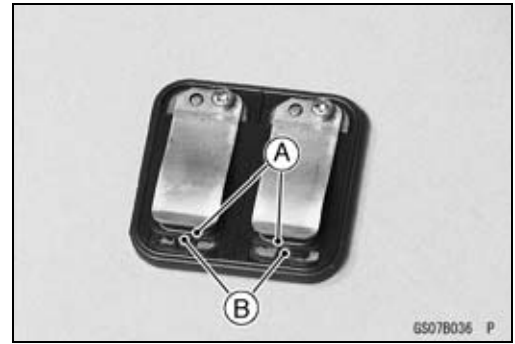

**CAUTION**

**Do not scrape off the deposits with a scraper as this could damage the rubber, requiring replacement of the suction valve assembly.**

**Engine Top End**

*Valve Clearance Inspection*

**Valve Clearance Inspection**

**NOTE**

○ *Valve clearance must be checked and adjusted when the engine is cold (at room temperature).*

- Remove:
  - Lower Fairing (see Frame chapter)
  - Crankshaft Sensor Cover
  - Cylinder Head Cover (see Engine Top End chapter)
- Position the crankshaft at 1, 4 piston TDC.
  - TDC Mark [A] for #1, 4 Pistons
  - Timing Mark [B] (crankcase halves mating surface)

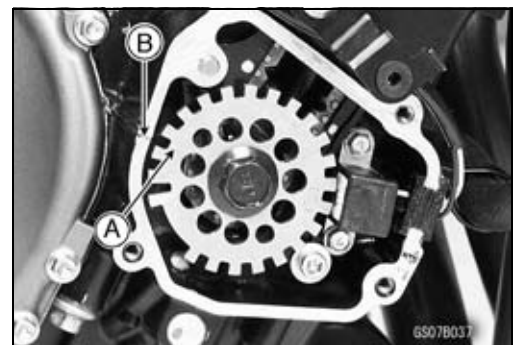

## 2-22 PERIODIC MAINTENANCE

### Maintenance Procedure

- Using a thickness gauge [A], measure the valve clearance between the cam and the valve lifter.

#### Valve Clearance

##### Standard:

Exhaust	0.17 ~ 0.22 mm (0.0067 ~ 0.0087 in.)
Inlet	0.15 ~ 0.24 mm (0.0059 ~ 0.0094 in.)

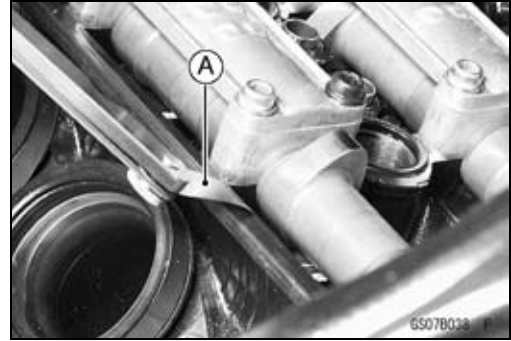

#### NOTE

- Thickness gauge is horizontally inserted on the valve lifter.

Appropriateness [A]

Inadequacy [B]

Thickness Gauge [C]

Horizontally Inserts [D]

Cam [E]

Valve Lifter [F]

Hits the Valve Lifter Ahead [G]

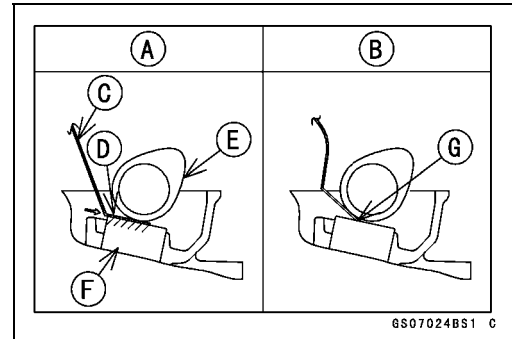

- When positioning #1 piston TDC at the end of the compression stroke:

Inlet Valve Clearance of #1 and #3 Cylinders

Exhaust Valve Clearance of #1 and #2 Cylinders

Measuring Valve [A]

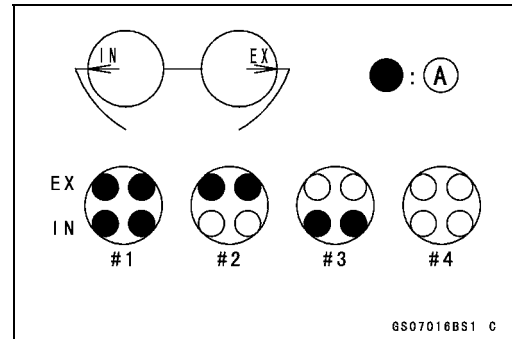

- When positioning #4 piston TDC at the end of the compression stroke:

Inlet Valve Clearance of #2 and #4 Cylinders

Exhaust Valve Clearance of #3 and #4 Cylinders

Measuring Valve [A]

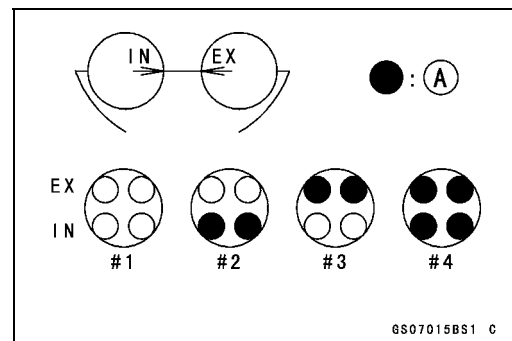

- ★ If the valve clearance is not within the specified range, first record the clearance, and then adjust it.

**Maintenance Procedure**

**Valve Clearance Adjustment**

- To change the valve clearance, remove the camshaft chain tensioner, camshafts and valve lifters. Replace the shim with one of a different thickness.

**NOTE**

○ Mark and record the locations of the valve lifters and shims so that they can be reinstalled in their original positions.

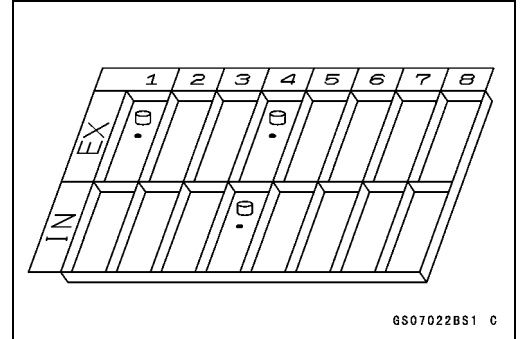

- Clean the shim to remove any dust or oil.
- Measure the thickness of the removed shim [A].
- Select a new shim thickness calculation as follows.
  - a + b - c = d
  - [a] Present Shim Thickness
  - [b] Measured Valve Clearance
  - [c] Specified Valve Clearance (Mean Value = 0.195)
  - [d] Replace Shim Thickness

**Example:**

$$1.600 + 0.31 - 0.195 = 1.715 \text{ mm}$$

○ Exchange the shim for the 1.725 size shim.



**CAUTION**

**Don't use the shims for another models. This could cause wear of the valve stem end, and valve stem damage.**

## 2-24 PERIODIC MAINTENANCE

### Maintenance Procedure

#### Adjustment Shims

Thickness	Part Number	Mark
1.300	92180-0108	130
1.325	92180-0109	133
1.350	92180-0110	135
1.375	92180-0111	138
1.400	92180-0112	140
1.425	92180-0113	143
1.450	92180-0114	145
1.475	92180-0115	148
1.500	92180-0116	150
1.525	92180-0117	153
1.550	92180-0118	155
1.575	92180-0119	158
1.600	92180-0120	160
1.625	92180-0121	163
1.650	92180-0122	165
1.675	92180-0123	168
1.700	92180-0124	170
1.725	92180-0125	173
1.750	92180-0126	175
1.775	92180-0127	178
1.800	92180-0128	180
1.825	92180-0129	183
1.850	92180-0130	185
1.875	92180-0131	188
1.900	92180-0132	190
1.925	92180-0133	193
1.950	92180-0134	195
1.975	92180-0135	198
2.000	92180-0136	200
2.025	92180-0137	203
2.050	92180-0138	205
2.075	92180-0139	208
2.100	92180-0140	210
2.125	92180-0141	213
2.150	92180-0142	215
2.175	92180-0143	218
2.200	92180-0144	220
2.225	92180-0145	223
2.250	92180-0146	225
2.275	92180-0147	228
2.300	92180-0148	230

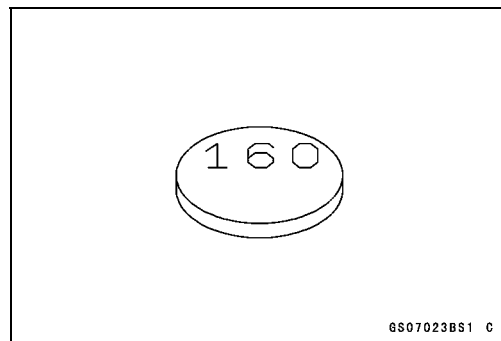



**Maintenance Procedure**

**CAUTION**

**Be sure to remeasure the clearance after selecting a shim. The clearance can be out of the specified range because of the shim tolerance.**

- If there is no valve clearance, use a shim that is a few sizes smaller, and remeasure the valve clearance.
- When installing the shim, face the marked side toward the valve lifter. At this time, apply engine oil to the shim or the valve lifter to keep the shim in place during camshaft installation.

**CAUTION**

**Do not put shim stock under the shim. This may cause the shim to pop out at high rpm, causing extensive engine damage.  
Do not grind the shim. This may cause it to fracture, causing extensive engine damage.**

- Apply engine oil to the valve lifter surface and install the lifter.
- Install the camshaft (see Engine Top End chapter).
- Recheck the valve clearance and readjust if necessary.
- Install the removed parts (see appropriate chapters).

**Clutch and Drive Train**

*Clutch Operation Inspection*

- Pull the clutch lever just enough to take up the free play [A].
- Measure the gap between the lever and the lever holder.
- ★ If the gap is too wide, the clutch may not release fully. If the gap is too narrow, the clutch may not engage fully. In either case, adjust it.

**Clutch Lever Free Play**

Standard: 2 ~ 3 mm (0.08 ~ 0.12 in.)



**⚠ WARNING**  
**To avoid a serious burn, never touch the engine or exhaust pipe during clutch adjustment.**

- Turn the adjuster [A] so that 5 ~ 6 mm (0.20 ~ 0.24 in.) [B] of threads is visible.

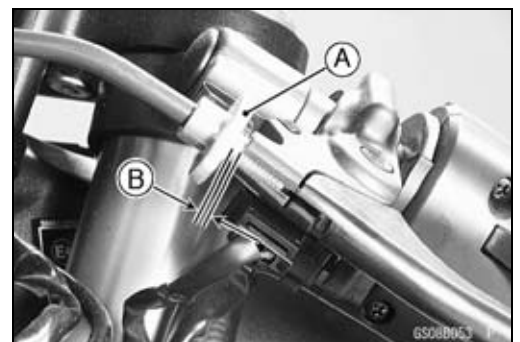

## 2-26 PERIODIC MAINTENANCE

### Maintenance Procedure

- Slide the dust cover [A] at the clutch cable lower end out of place.
- Loosen both adjusting nuts [B] at the clutch cover as far as they will go.
- Pull the clutch outer cable [C] tight and tighten the adjusting nuts against the bracket [D].
- Slip the rubber dust cover back onto place.
- Turn the adjuster at the clutch lever until the free play is correct.

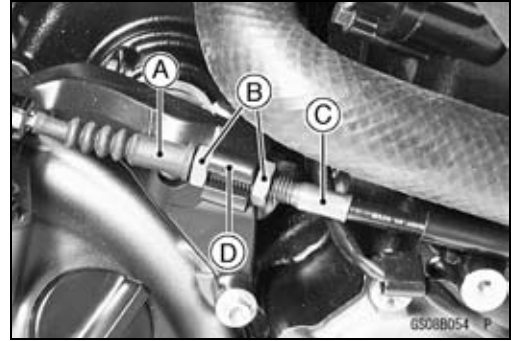

- Push the release lever [A] toward the front of the motorcycle until it becomes hard to turn.
- At this time, the release lever should have the proper angle shown.
- ★ If the angle is wrong, check the clutch and release parts for wear.



#### **⚠ WARNING**

**Be sure that the outer cable end at the clutch lever is fully seated in the adjuster at the clutch lever, or it could slip into place later, creating enough cable play to prevent clutch disengagement.**

- After the adjustment, start the engine and check that the clutch does not slip and that it releases properly.

#### *Drive Chain Lubrication Condition Inspection*

- If a special lubricant is not available, a heavy oil such as SAE 90 is preferred to a lighter oil because it will stay on the chain longer and provide better lubrication.
- If the chain appears especially dirty, clean it before lubrication.

#### **CAUTION**

**The O-rings between the side plates seal in the lubricant between the pin and the bushing. To avoid damaging the O-rings and resultant loss of lubricant, observe the following rules.**

**Use only kerosene or diesel oil for cleaning of the O-ring of the drive chain.**

**Any other cleaning solution such as gasoline or trichloroethylene will cause deterioration and swelling of the O-ring.**

**Immediately blow the chain dry with compressed air after cleaning.**

**Complete cleaning and drying the chain within 10 minutes.**

**Maintenance Procedure**

- Apply oil to the sides of the rollers so that oil will penetrate to the rollers and bushings. Apply the oil to the O-rings so that the O-rings will be coated with oil.
- Wipe off any excess oil.
  - Oil Applied Areas [A]
  - O-ring [B]

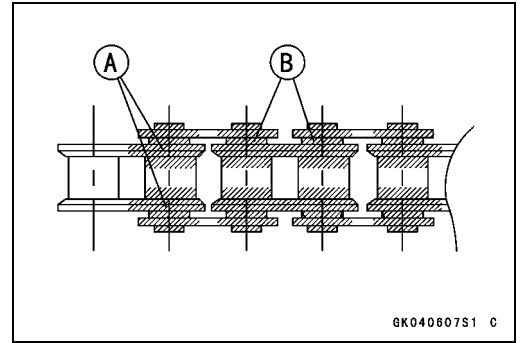

**Drive Chain Slack Inspection**

**NOTE**

- Check the slack with the motorcycle setting on its side stand.
- Clean the chain if it is dirty, and lubricate it if it appears dry.
- Check the wheel alignment (see Wheel Alignment Inspection).
- Rotate the rear wheel to find the position where the chain is tightest.
- Measure the vertical movement (chain slack) [A] midway between the sprockets.
- ★ If the chain slack exceeds the standard, adjust it.

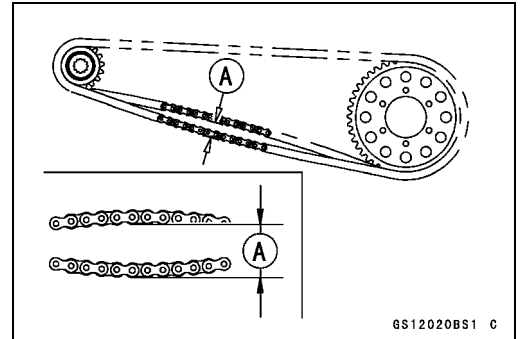

**Chain Slack**

**Standard:** 35 ~ 45 mm (1.4 ~ 1.8 in.)

**Drive Chain Slack Adjustment**

- Remove the cotter pin [A], and loosen the axle nut [B].
- Loosen the both chain adjuster locknuts [C].
- ★ If the chain is too loose, turn out the left and right chain adjuster [D] evenly.
- ★ If the chain is too tight, turn in the left and right chain adjusters evenly, and kick the wheel forward.
- Turn both chain adjusters evenly until the drive chain has the correct amount of slack. To keep the chain and wheel properly aligned, the notch [E] on the left wheel alignment indicator [F] should align with the same swingarm mark or position [G] that the right indicator notch aligns with.

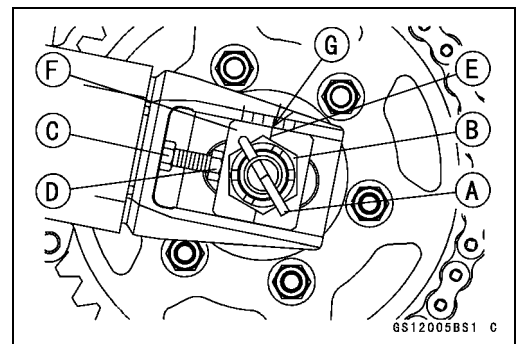

**⚠ WARNING**

**Misalignment of the wheel will result in abnormal wear and may result in an unsafe riding condition.**

- Tighten both chain adjuster locknuts securely.
- Tighten the axle nut.
  - Torque - Rear Axle Nut: 108 N·m (11 kgf·m, 81 ft·lb)**
- Turn the wheel, measure the chain slack again at the tightest position, and readjust if necessary.
- Insert a new cotter pin into the axle and bend its end securely.

## 2-28 PERIODIC MAINTENANCE

### Maintenance Procedure

- Insert a new cotter pin [A].

#### NOTE

- When inserting the cotter pin, if the slots in the nut do not align with the cotter pin hole in the axle, tighten the nut clockwise [B] up to next alignment.
- It should be within 30 degree.
- Loosen once and tighten again when the slot goes past the nearest hole.

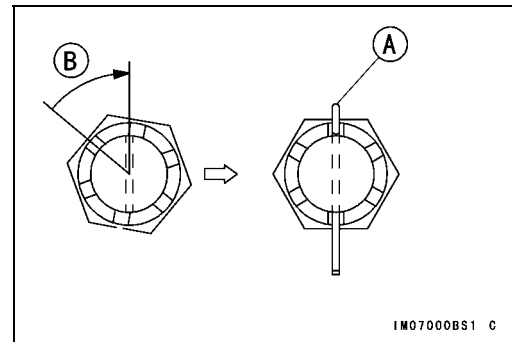

- Bend the cotter pin [A] over the nut [B].

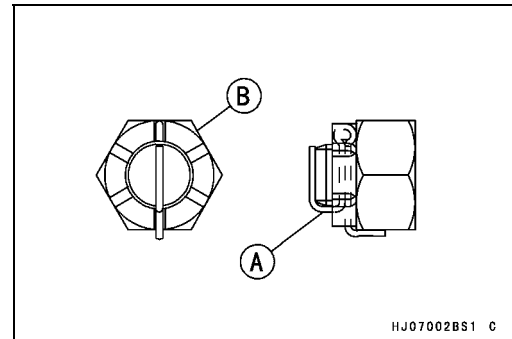

### Wheel Alignment Inspection

- Check that the notch [A] on the left alignment indicator [B] aligns with the same swingarm mark or position [C] that the right alignment indicator notch aligns with.
- ★ If they do not, adjust the chain slack and align the wheel alignment (see Drive Chain Slack Adjustment).

#### NOTE

- Wheel alignment can be also checked using the straightedge or string method.

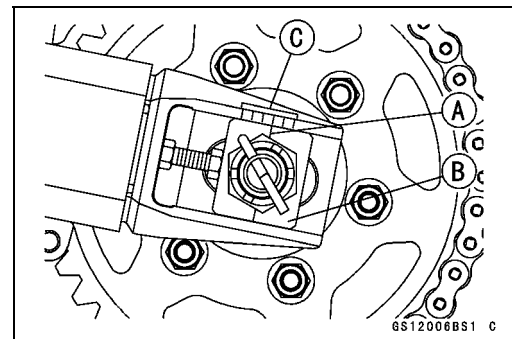

### ⚠ WARNING

Misalignment of the wheel will result in abnormal wear, and may result in an unsafe riding condition.

### Drive Chain Wear Inspection

- Remove:
  - Chain Cover
- Rotate the rear wheel to inspect the drive chain for damaged rollers, and loose pins and links.
- ★ If there is any irregularity, replace the drive chain.
- ★ Lubricate the drive chain if it appears dry.
- Stretch the chain taut by hanging a 98 N (10 kg, 20 lb) weight [A] on the chain.
- Measure the length of 20 links [B] on the straight part [C] of the chain from the pin center of the 1st pin to the pin center of the 21st pin. Since the chain may wear unevenly, take measurements at several places.
- ★ If any measurements exceed the service limit, replace the chain. Also, replace the front and rear sprockets when the drive chain is replaced.

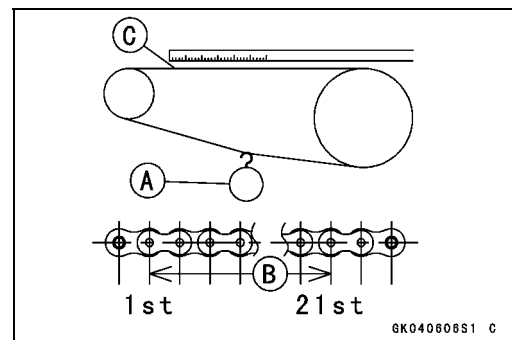

### Drive Chain 20-link Length

- Standard: 317.5 ~ 318.2 mm (12.50 ~ 12.53 in.)
- Service Limit: 323 mm (12.7 in.)

Maintenance Procedure

**⚠ WARNING**

If the drive chain wear exceeds the service limit, replace the chain or an unsafe riding condition may result. A chain that breaks or jumps off the sprockets could snag on the engine sprocket or lock the rear wheel, severely damaging the motorcycle and causing it to go out of control.

For safety, use only the standard chain. It is an endless type and should not be cut for installation.

**Standard Chain**

- Make: RK EXCEL
- Type: RK 525MFO
- Link: 110 links

*Drive Chain Guide Wear Inspection*

- Remove:
  - Drive Chain (see Final Drive chapter)
- Visually inspect the chain guide [A].
- ★ Replace the chain guide if it shows any signs of abnormal wear or damage.

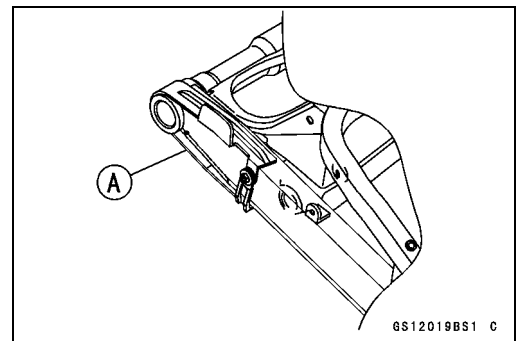

**Wheels/Tires**

*Tire Air Pressure Inspection*

- Measure the tire air pressure with an air pressure gauge [A] when the tires are cold (that is, when the motorcycle has not been ridden more than a mile during the past 3 hours).
- Install the air valve cap.
- ★ Adjust the tire air pressure according to the specifications if necessary.

**Air Pressure (when Cold)**

- Front: Up to 180 kg (397 lb)  
250 kPa (2.5 kgf/cm<sup>2</sup>, 36 psi)
- Rear: Up to 180 kg (397 lb)  
290 kPa (2.9 kgf/cm<sup>2</sup>, 42 psi)

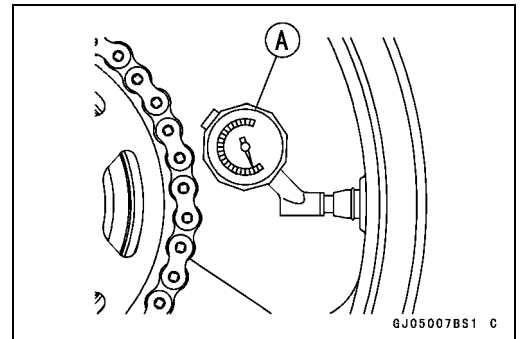

*Wheel/Tire Damage Inspection*

- Remove any imbedded stones [A] or other foreign particles [B] from tread.
- Visually inspect the tire for cracks and cuts, and replace the tire if necessary. Swelling or high spots indicate internal damage, requiring tire replacement.
- Visually inspect the wheel for cracks, cuts and dents damage.
- ★ If any damage is found, replace the wheel if necessary.

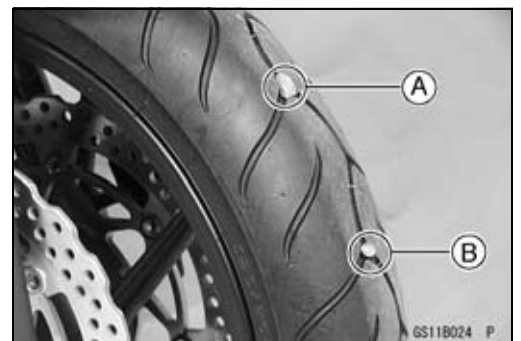

## 2-30 PERIODIC MAINTENANCE

### Maintenance Procedure

#### Tire Tread Wear Inspection

As the tire tread wears down, the tire becomes more susceptible to puncture and failure. An accepted estimate is that 90% of all tire failures occur during the last 10% of tread life (90% worn). So it is false economy and unsafe to use the tires until they are bald.

- Measure the tread depth at the center of the tread with a depth gauge [A]. Since the tire may wear unevenly, take measurement at several places.
- ★ If any measurement is less than the service limit, replace the tire (see Wheels/Tires chapter).

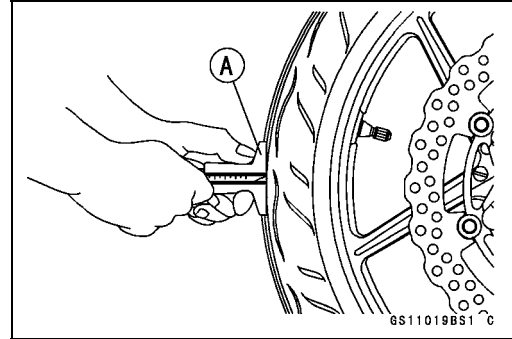

#### Tread Depth

##### Front:

- Standard: 4.0 mm (0.16 in.)
- Service Limit: 1 mm (0.04 in.)  
(AT, CH, DE,) 1.6 mm (0.06 in.)

##### Rear:

- Standard: 5.5 mm (0.22 in.)
- Service Limit: 2 mm (0.08 in.) (Up to 130 km/h)  
3 mm (0.12 in.) (Over 130 km/h)

### **⚠ WARNING**

To ensure safe handling and stability, use only the recommended standard tires for replacement, inflated to the standard pressure.

### NOTE

- Most countries may have their own regulations a minimum tire tread depth: be sure to follow them.
- Check and balance the wheel when a tire is replaced with a new one.

#### Wheel Bearing Damage Inspection

- Using a jack and attachment, raise the front wheel off the ground (see Wheels/Tires chapter).
- Turn the handlebar all the way to the right or left.
- Inspect the roughness of the front wheel bearing by pushing and pulling [A] the wheel.
- Spin [B] the front wheel lightly, and check for smoothly turn, roughness, binding or noise.
- ★ If roughness, binding or noise is found, remove the front wheel and inspect the wheel bearing (see Wheels/Tires chapter).



**Maintenance Procedure**

- Using a jack and attachment, raise the rear wheel off the ground (see *Wheels/Tires* chapter).
- Inspect the roughness of the rear wheel bearing by pushing and pulling [A] the wheel.
- Spin [B] the rear wheel lightly, and check for smoothly turn, roughness, binding or noise.
- ★ If roughness, binding or noise is found, remove the rear wheel and inspect the wheel bearing (see *Wheels/Tires* chapter) and coupling (see *Final Drive* chapter).

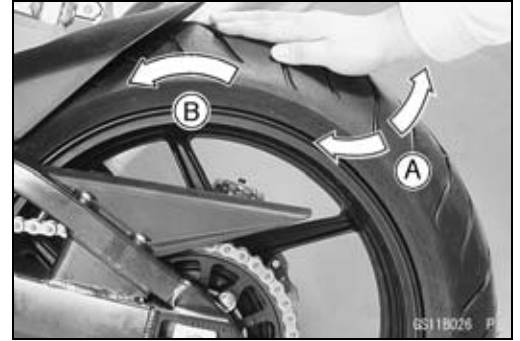

**Brake System**

*Brake Fluid Leak (Brake Hose and Pipe) Inspection*

- Apply the brake lever or pedal and inspect the brake fluid leak from the brake hoses [A] and fittings.
- ★ If the brake fluid leaked from any position, inspect or replace the problem part.

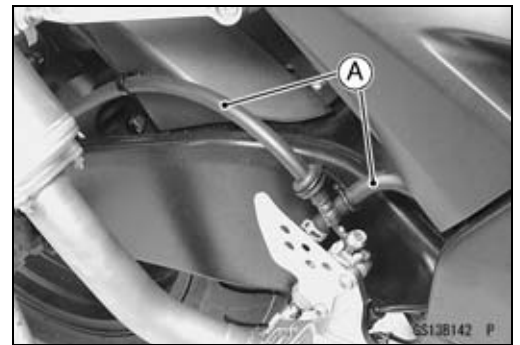

*Brake Hose Damage and Installation Condition Inspection*

- Inspect the brake hoses and fittings for deterioration, cracks and signs of leakage.
- The high pressure inside the brake line can cause fluid to leak [A] or the hose to burst if the line is not properly maintained. Bend and twist the rubber hose while examining it.
- ★ Replace the hose if any crack [B], bulge [C] or leakage is noticed.
- ★ Tighten any banjo bolts.

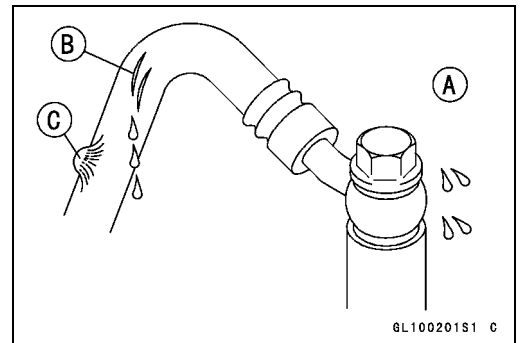

**Torque - Brake Hose Banjo Bolts: 25 N·m (2.5 kgf·m, 18 ft·lb)**

- Inspect the brake hose routing.
- ★ If any brake hose routing is incorrect, route the brake hose according to Cable, Wire and Hose Routing section in the Appendix chapter.

*Brake Operation Inspection*

- Inspect the operation of the front and rear brake by running the vehicle on the dry road.
- ★ If the brake operation is insufficiency, inspect the brake system.

**⚠ WARNING**

**When inspecting by running the vehicle, note a surrounding traffic situation enough in the place of safety.**

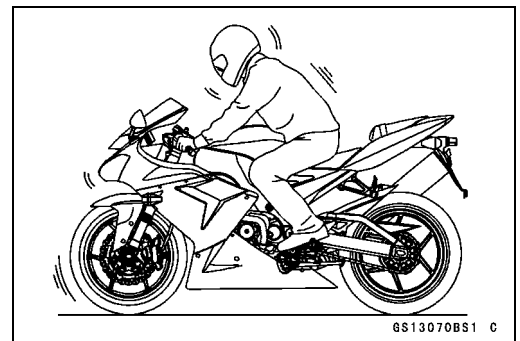

## 2-32 PERIODIC MAINTENANCE

### Maintenance Procedure

#### Brake Fluid Level Inspection

- Check that the brake fluid level in the front brake reservoir [A] is above the lower level line [B].

#### NOTE

○ Hold the reservoir horizontal by turning the handlebar when checking brake fluid level.

- ★ If the fluid level is lower than the lower level line, fill the reservoir to the upper level line [C].



- Check that the brake fluid level in the rear brake reservoir [A] is above the lower level [B].

- ★ If the fluid level is lower than the lower level line, remove the reservoir cap and fill the reservoir to the upper level line [C].

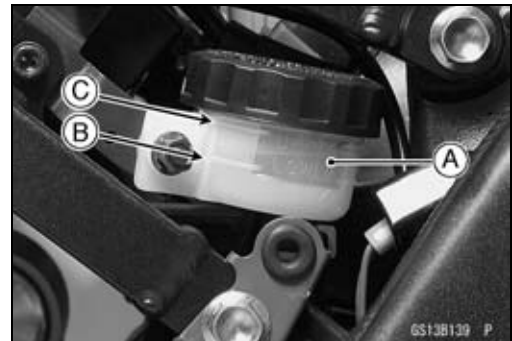

- Follow the procedure below to install the brake fluid reservoir cap correctly.

- First, tighten the brake fluid reservoir cap [B] clockwise [C] by hand until the resistance is felt fully; then, tighten the cap an additional 1/6 turn [D] while holding the brake fluid reservoir body [A].

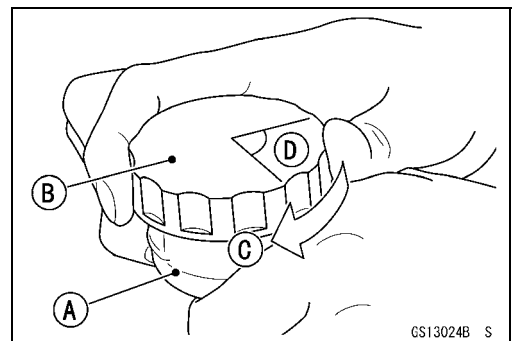

#### **⚠ WARNING**

**Change the brake fluid in the brake line completely if the brake fluid must be refilled but the type and brand of the brake fluid that is already in the reservoir are unidentified. After changing the fluid, use only the same type and brand of fluid thereafter.**

#### Recommended Disc Brake Fluid

Grade: DOT4

#### Brake Pad Wear Inspection

- Remove the brake pads (see Brakes chapter).
- Check the lining thickness [A] of the pads in each caliper.
- ★ If the lining thickness of either pad is less than the service limit [B], replace both pads in the caliper as a set.

#### Pad Lining Thickness

##### Standard:

Front 4 mm (0.16 in.)

Rear 5 mm (0.20 in.)

Service Limit: 1 mm (0.04 in.)

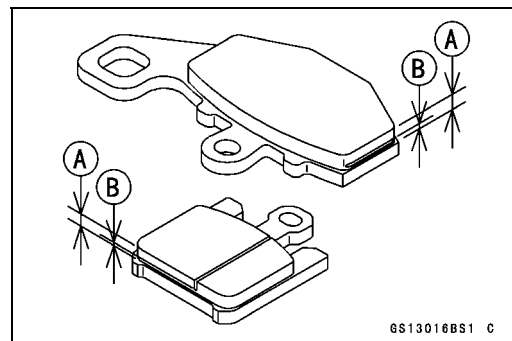



**Maintenance Procedure**

*Brake Light Switch Operation*

- Turn on the ignition switch.
- The brake light [A] should go on when the brake lever is applied or after the brake pedal is depressed about 10 mm (0.39 in.).

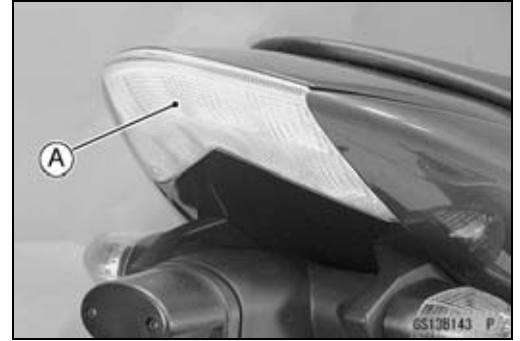

★ If it does not, adjust the brake light switch.

- Remove:
  - Right Footpeg Stay Bolts [A]
  - Footpeg Stay Assy



- While holding the switch body, turn the adjusting nut to adjust the switch.
  - Switch Body [A]
  - Adjusting Nut [B]
  - Light sooner as the body rises [C]
  - Light later as the body lowers [D]

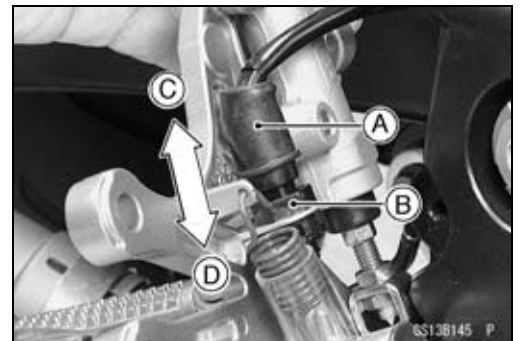

**CAUTION**

**To avoid damaging the electrical connections inside the switch, be sure that the switch body does not turn during adjustment.**

- ★ If it does not go on, inspect or replace the following items.
  - Battery (see Electrical System chapter)
  - Brake Light (see Electrical System chapter)
  - Main Fuse 30 A and Taillight Fuse 10 A (see Electrical System chapter)
  - Front Brake Light Switch [A] (see Electrical System chapter)
  - Rear Brake Light Switch (see Electrical System chapter)
  - Harness (see Wiring Inspection in Electrical System chapter)



## 2-34 PERIODIC MAINTENANCE

### Maintenance Procedure

#### Suspensions

##### Front Forks/Rear Shock Absorber Operation Inspection

- Pump the forks down and up [A] 4 or 5 times, and inspect the smooth stroke.
- ★ If the forks do not smoothly or noise is found, inspect the fork oil level or fork clamps (see Suspension chapter).



- Pump the seat down and up [A] 4 or 5 times, and inspect the smooth stroke.
- ★ If the shock absorber does not smoothly stroke or noise is found, inspect the oil leak (see Rear Shock Absorber Oil Leak Inspection) or shock absorber clamps (see Suspension chapter).

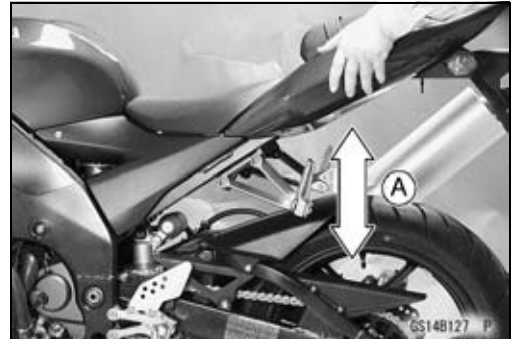

##### Front Fork Oil Leak Inspection

- Visually inspect the front forks [A] for oil leakage.
- ★ Replace or repair any defective parts, if necessary.



##### Rear Shock Absorber Oil Leak Inspection

- Visually inspect the shock absorber [A] for oil leakage.
- ★ If the oil leakage is found on it, replace the shock absorber with a new one.



##### Rocker Arm Operation Inspection

- Remove the lower fairings (see Frame chapter).
- Pump the seat down and up 4 or 5 times, and inspect the smooth stroke.
- ★ If the rocker arm [A] does not smoothly stroke or noise is found, inspect the fasteners and bearings (see Suspension chapter).



## Maintenance Procedure

### Tie-rod Operation Inspection

- Remove the lower fairings (see Frame chapter).
- Pump the seat down and up 4 or 5 times, and inspect the smooth stroke.
- ★ If the tie-rods [A] do not smoothly stroke or noise is found, inspect the fasteners and tie-rod bearings (see Suspension chapter).

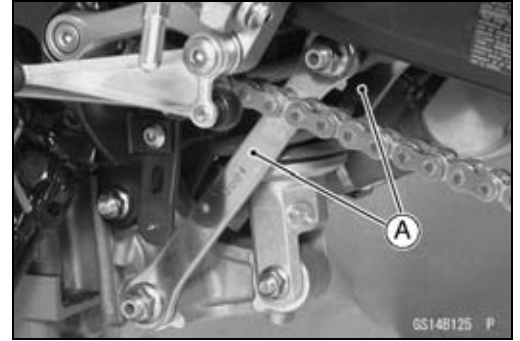

## Steering System

### Steering Play Inspection

#### Steering Play Inspection

- Lift the front wheel off the ground using the jack.

**Special Tool - Jack: 57001-1238**

- With the front wheel pointing straight ahead, alternately tap each end of the handlebar. The front wheel should swing fully left and right from the force of gravity until the fork hits the stop.
- ★ If the wheel binds or catches before the stop, the steering is too tight.
- Feel for steering looseness by pushing and pulling the forks.
- ★ If you feel looseness, the steering is too loose.



### NOTE

- The cables and wiring will have some effect on the motion of the fork which must be taken into account.
- Be sure the wires and cables are properly routed.
- The bearings must be in good condition and properly lubricated in order for any test to be valid.

### Steering Play Adjustment

- Remove:
  - Stem Head Nut [A] and Washer [B]
- Loosen the upper fork clamp bolts [C] and handlebar bolts [D].
- Remove the stem head [E] with handlebar.

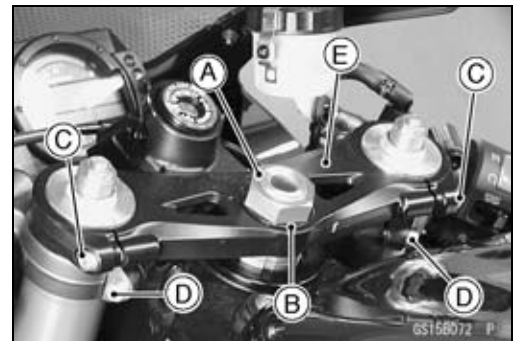

- Bend the claw washer tabs [A].
- Remove the steering stem locknut [B] and claw washer [C].



## 2-36 PERIODIC MAINTENANCE

### Maintenance Procedure

- Adjust the steering.
  - Special Tool - **Steering Stem Nut Wrench: 57001-1100**
- ★ If the steering is too tight, loosen the stem nut a fraction of a turn.
- ★ If the steering is too loose, tighten the stem nut a fraction of a turn.

#### NOTE

○ Turn the stem nut 1/8 turn at time maximum.

- Install the claw washer [A] so that its bent side [B] faces upward, and engage the bent claws with the grooves of stem locknut [C].
- Hand tighten the stem locknut until it touches the claw washer.
- Tighten the stem locknut clockwise until the claws are aligned with the grooves (ranging from 2nd to 4th) of stem nut [D], and bend the 2 claws downward [E].

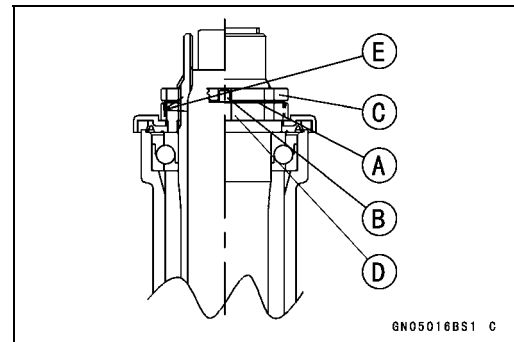

- Tighten:
  - Torque - **Upper Fork Clamp Bolts: 20 N·m (2.0 kgf·m, 14.5 ft·lb)**
  - Handlebar Bolts: 25 N·m (2.5 kgf·m, 18 ft·lb)**
  - Steering Stem Head Nut: 78 N·m (8.0 kgf·m, 58 ft·lb)**
- Check the steering again.
- ★ If the steering is still too tight or too loose, repeat the adjustment.

#### Steering Stem Bearing Lubrication

- Remove the steering stem (see Steering chapter).
- Using a high flash-point solvent, wash the upper and lower ball bearings in the cages, and wipe the upper and lower outer races, which are press-fitted into the frame head pipe, clean off grease and dirt.
- Visually check the outer races and the ball bearings.
- ★ Replace the bearing assemblies if they show wear or damage.
- Pack the upper and lower ball bearings [A] in the cages with grease, and apply a light coat of grease to the upper and lower outer races.
- Install the steering stem, and adjust the steering.

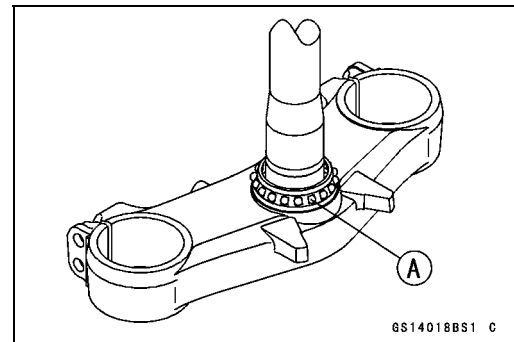

**Maintenance Procedure**

**Electrical System**

*Lights and Switches Operation Inspection*

**First Step**

- Turn on the ignition switch.
- The following lights should go on according to below table.

City Light [A]	goes on
Taillight [B]	goes on
License Plate Light [C]	goes on
Meter Panel LCD [D]	goes on
Neutral Indicator LED [E]	goes on
Oil Pressure Warning Indicator LED [F]	goes on
FI Indicator LED [G]	goes on (about 2 seconds)

★ If the light does not go on, inspect or replace the following item.

- Battery (see Electrical System chapter)
- Applicable Bulb (see Electrical System chapter)
- Meter Unit for Meter Panel LED (see Electrical System chapter)
- Meter Unit for Neutral Indicator LED (see Electrical System chapter)
- Meter Unit for Oil Pressure Warning Indicator LED (see Electrical System chapter)
- Meter Unit and ECU for FI Indicator LED (see Electrical System chapter)
- Main Fuse 30 A and Taillight Fuse 10 A (see Electrical System chapter)
- Ignition Switch (see Electrical System chapter)
- Gear Position Switch (for Neutral Indicator LED, see Electrical System chapter)
- Harness (see Wiring Inspection in Electrical System chapter)

- Turn off the ignition switch.
- The all lights should go off (for the immobilizer model, FI indicator LED will blink. see Electrical System chapter).
- ★ If the light does not go off, replace the ignition switch.

**Second Step**

- Turn the ignition switch to P (Park) position.
- The city light, taillight and license plate light should go on.
- ★ If the light does not go on, inspect or replace the following item.
- Ignition Switch (see Electrical System chapter)

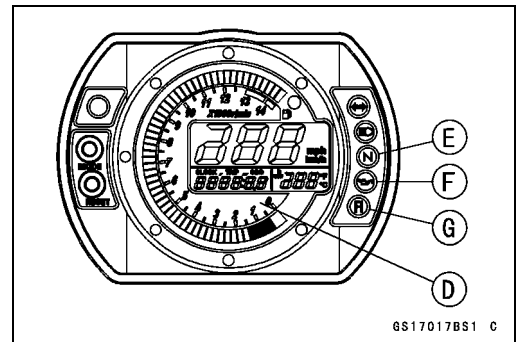
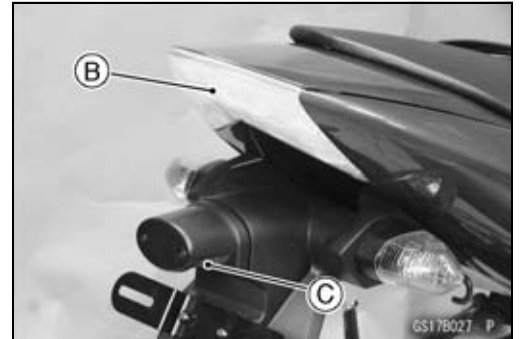

## 2-38 PERIODIC MAINTENANCE

### Maintenance Procedure

#### Third Step

- Turn on the turn signal switch [A] (left or right position).
- The left or right turn signal lights [B] (front and rear) according to the switch position should flash.
- The turn signal indicator LED [C] in the meter unit should flash.

★ If the each light does not flash, inspect or replace the following item.

Turn Signal Light Bulb (see Electrical System chapter)

Meter Unit for Turn Signal Light Indicator LED (see Electrical System chapter)

Turn Signal Relay Fuse 10 A (see Electrical System chapter)

Turn Signal Switch (see Electrical System chapter)

Turn Signal Relay (see Electrical System chapter)

Harness (see Wiring Inspection in Electrical System chapter)

- Push the turn signal switch.
  - The turn signal lights and indicator LED should go off.
- ★ If the light does not go off, inspect or replace the following item.

Turn Signal Switch (see Electrical System chapter)

Turn Signal Relay (see Electrical System chapter)

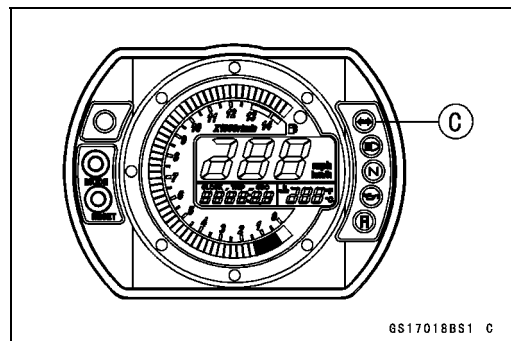
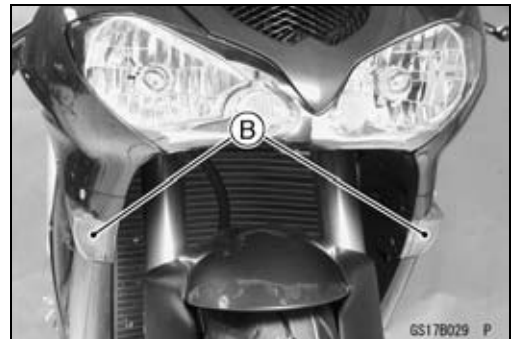
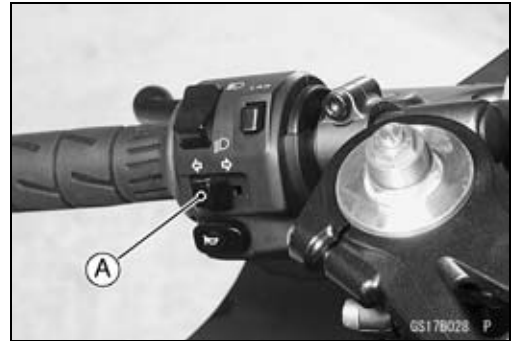

#### Fourth Step

- Set the dimmer switch [A] to low beam position.
  - Start the engine.
  - The low beam headlight should go on.
- ★ If the low beam headlight does not go on, inspect or replace the following item.

Headlight Low Beam Bulb (see Electrical System chapter)

Headlight Fuse 10 A (see Electrical System chapter)

Dimmer Switch (see Electrical System chapter)

Headlight Relay in Relay Box (see Electrical System chapter)

Harness (see Wiring Inspection in Electrical System chapter)



**Maintenance Procedure**

- Set the dimmer switch to high beam position.
- The low beam [A] and high beam [B] headlights should go on.
- The high beam indicator LED [C] should go on.
- ★ If the high beam headlight and/or high beam indicator LED does not go on, inspect or replace the following item.
  - Headlight High Beam Bulb (see Electrical System chapter)
  - Dimmer Switch (see Electrical System chapter)
- Turn off the engine stop switch.
- The low beam and high beam headlights should stay going on.
- ★ If the headlights and high beam indicator LED does go off, inspect or replace the following item.
  - Headlight Relay in Relay Box (see Electrical System chapter)
- Turn off the ignition switch.
- The headlights and high beam indicator LED should go off.

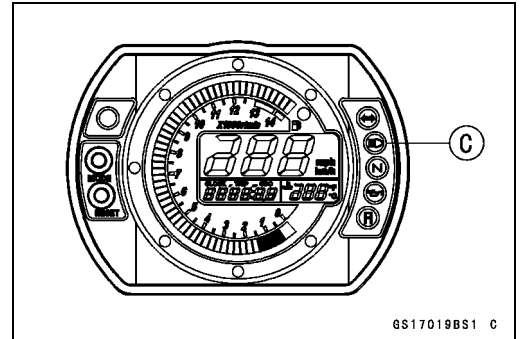

*Headlight Aiming Inspection*

- Inspect the headlight beam for aiming.
- ★ If the headlight beam points to one side rather than straight ahead, adjust the horizontal beam.

**Headlight Beam Horizontal Adjustment**

- Turn the horizontal adjuster [A] in both headlights in or out until the beam points straight ahead.
- ★ If the headlight beam points too low or high, adjust the vertical beam.

**Headlight Beam Vertical Adjustment**

- Turn the vertical adjuster [B] in both headlights in or out with a screwdriver to adjust the headlight vertically.



## 2-40 PERIODIC MAINTENANCE

### Maintenance Procedure

#### NOTE

- ON high beam, the brightest points should be slightly below horizontal with the motorcycle on its wheels and the rider seated. Adjust the headlight to the proper angle according to local regulations.
- For US model, the proper angle is 0.4 degrees below horizontal. This is 50 mm (2 in.) drop at 7.6 m (25 ft) measured from the center of the headlight with the motorcycle on its wheels and the rider seated.

50 mm (2 in.) [A]

Center of Brightest Spot [B]

7.6 m (25 ft) [C]

Low Beam [D]

Height of Headlight Center [E]

High Beam [F]

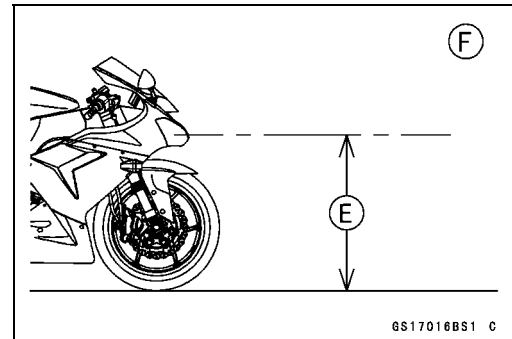
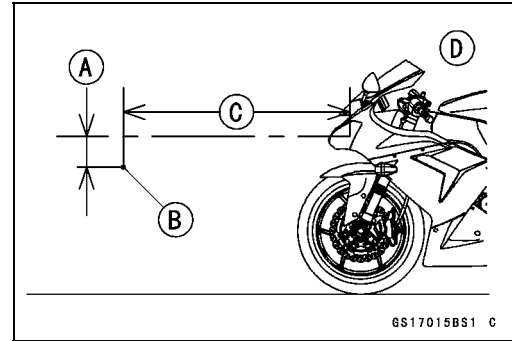

#### Side Stand Switch Operation Inspection

- Inspect the side stand switch [A] operation accordance to below table.

#### Sidestand Switch Operation

Side Stand	Gear Position	Clutch Lever	Engine Start	Engine Run
Up	Neutral	Released	Starts	Continue running
Up	Neutral	Pulled in	Starts	Continue running
Up	In Gear	Released	Doesn't start	Continue running
Up	In Gear	Pulled in	Starts	Continue running
Down	Neutral	Released	Starts	Continue running
Down	Neutral	Pulled in	Starts	Continue running
Down	In Gear	Released	Doesn't start	Stops
Down	In Gear	Pulled in	Doesn't start	Stops

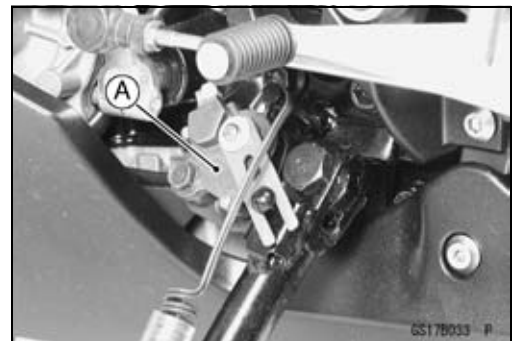



**Maintenance Procedure**

★ If the side stand switch operation does not work, inspect or replace the following item.

- Battery (see Electrical System chapter)
- Main Fuse 30 A (see Electrical System chapter)
- Ignition Fuse 10 A (see Electrical System chapter)
- Ignition Switch (see Electrical System chapter)
- Side Stand Switch (see Electrical System chapter)
- Engine Stop Switch (see Electrical System chapter)
- Starter Button (see Electrical System chapter)
- Gear Position Switch (see Electrical System chapter)
- Starter Control Relay (see Electrical System chapter)
- Relay Box (see Electrical System chapter)
- Starter Circuit Relay (see Electrical System chapter)
- Harness (see Wiring Inspection in Electrical System chapter)

★ If the all parts are good condition, replace the ECU.

*Engine Stop Switch Operation Inspection*

**First Step**

- Turn on the ignition switch.
  - Set the neutral position.
  - Turn the engine stop switch to stop position [A].
  - Push the starter button.
  - The engine does not start.
- ★ If the engine starts, inspect or replace the following item.
- Engine Stop Switch (see Electrical System chapter)



**Second Step**

- Turn on the ignition switch.
  - Set the neutral position.
  - Turn the engine stop switch to run position [A].
  - Push the starter button and run the engine.
  - Turn the engine stop switch to stop position.
  - Immediately the engine should be stop.
- ★ If the engine does not stop, inspect or replace the following item.
- Engine Stop Switch (see Electrical System chapter)
- ★ If the engine stop switch is good condition, replace the ECU.



## 2-42 PERIODIC MAINTENANCE

### Maintenance Procedure

#### Others

##### *Chassis Parts Lubrication*

- Before lubricating each part, clean off any rusty spots with rust remover and wipe off any grease, oil, dirt, or grime.
- Lubricate the points listed below with indicated lubricant.

#### NOTE

○ *Whenever the vehicle has been operated under wet or rainy conditions, or especially after using a high-pressure water spray, perform the general lubrication*

#### **Pivots: Lubricate with Motor Oil.**

Clutch Lever  
Brake Lever  
Brake Pedal  
Side Stand  
Rear Brake Joint Pin

#### **Points: Lubricate with Grease.**

Clutch Inner Cable Upper and Lower Ends [A]  
Throttle Inner Cable Upper and Lower Ends

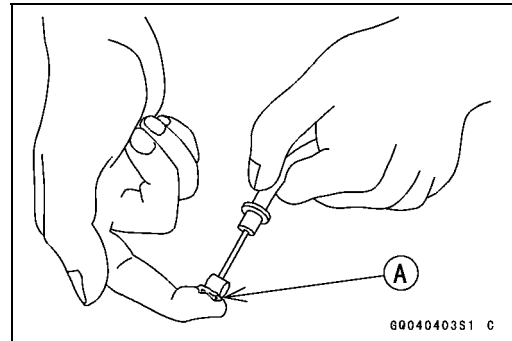

#### **Cables: Lubricate with Rust Inhibitor**

Throttle Cables  
Clutch Cable

- Lubricate the cables by seeping the oil between the cable and housing.
- The cable may be lubricated by using a commercially available pressure cable lubricator with an aerosol cable lubricant.

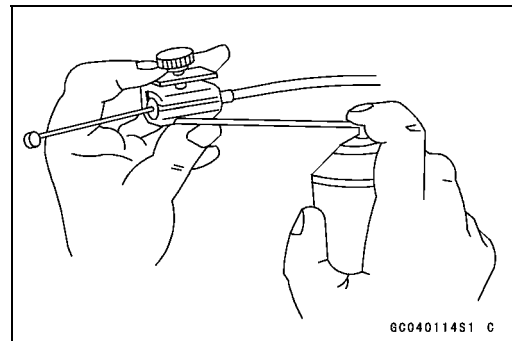

**Maintenance Procedure**

- With the cable disconnected at both ends, the inner cable should move freely [A] within the cable housing.
- ★ If cable movement is not free after lubricating, if the cable is frayed [B], or if the cable housing is kinked [C], replace the cable.

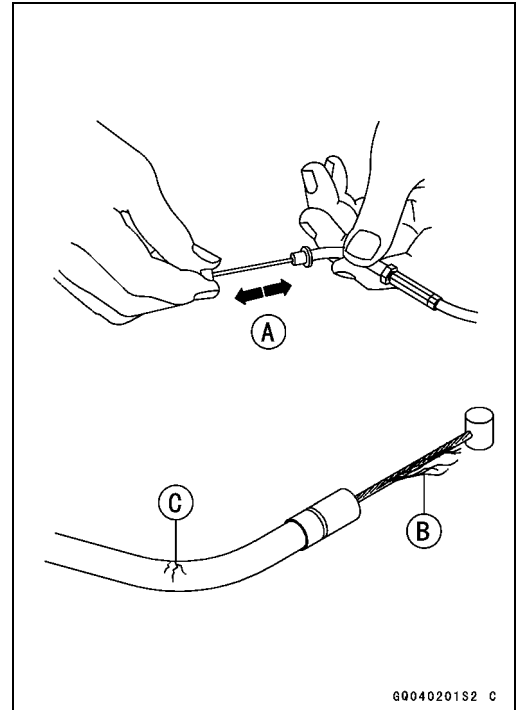

**Bolts, Nuts and Fasteners Tightness Inspection**

- Check the tightness of the bolts and nuts listed here. Also, check to see that each cotter pin is in place and in good condition.

**NOTE**

○ *For the engine fasteners, check the tightness of them when the engine is cold (at room temperature).*

- ★ If there are loose fasteners, retorque them to the specified torque following the specified tightening sequence. Refer to the appropriate chapter for torque specifications. If torque specifications are not in the appropriate chapter, see the Standard Torque Table. For each fastener, first loosen it by 1/2 turn, then tighten it.
- ★ If cotter pins are damaged, replace them with new ones.

## 2-44 PERIODIC MAINTENANCE

### Maintenance Procedure

---

#### Bolt, Nut and Fastener to be checked

##### Wheels:

- Front Axle Nut
- Front Axle Clamp Bolt
- Rear Axle Nut
- Rear Axle Nut Cotter Pin

##### Brakes:

- Front Master Cylinder Clamp Bolts
- Caliper Mounting Bolts
- Rear Master Cylinder Mounting Bolts
- Brake Lever Pivot Nut
- Brake Pedal Bolt
- Brake Rod Joint Cotter Pin

##### Suspension:

- Front Fork Clamp Bolts
- Front Fender Mounting Bolts
- Rear Shock Absorber Mounting Nuts
- Swingarm Pivot Shaft Nut
- Uni-track Link Nuts

##### Steering:

- Stem Head Nut
- Handlebar Mounting Bolts

##### Engine:

- Engine Mounting Bolts
- Cylinder Head Bolts
- Muffler Mounting Bolts
- Exhaust Manifold Holder Nuts
- Muffler Connecting Clamp Bolt
- Clutch Lever Pivot Nut

##### Others:

- Side Stand Bolt
- Footpeg Mounting Bolts
- Footpeg Bracket Mounting Bolts

### Replacement Parts

#### *Fuel Hose Replacement*

- Remove the fuel tank (see Fuel System (DFI) chapter).
- Be sure to place a piece of cloth [A] around the fuel hose joint.
- Push [B] the joint lock claws [C].

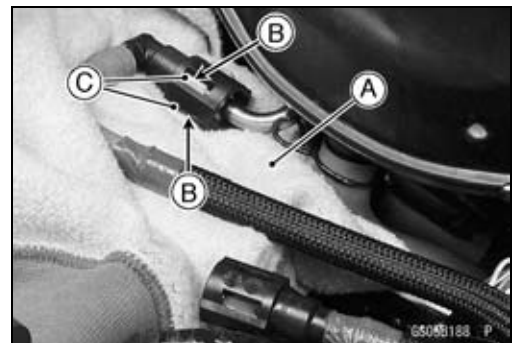

**Maintenance Procedure**

- Pull the joint lock [A] as shown.
- Pull the fuel hose joint [B] out of the delivery pipe.

**⚠ WARNING**  
**Be prepared for fuel spillage; any spilled fuel must be completely wiped up immediately. When the fuel hose is disconnected, fuel spills out from the hose and the pipe. Cover the hose connection with a clean shop towel to prevent fuel spillage.**

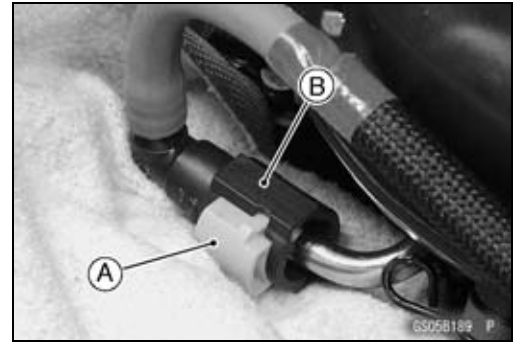

- Install the new fuel hose.
- Pull [A] the joint lock [B] fully as shown.

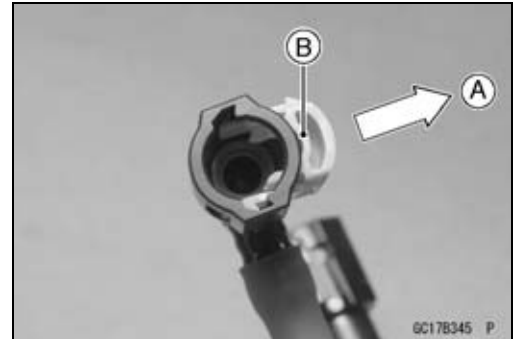

- Insert the fuel hose joint [A] straight onto the delivery pipe until the hose joint clicks.
- Push [B] the joint lock [C] until the hose joint clicks.

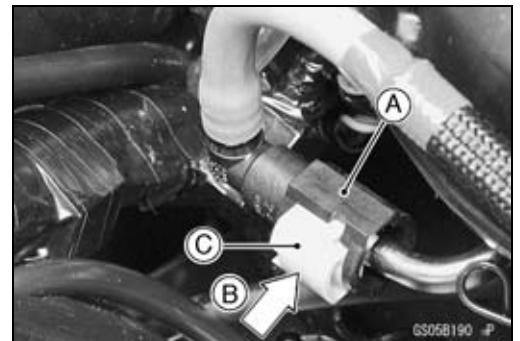

- Push and pull [A] the fuel hose joint [B] back and forth more than two times and make sure it is locked and doesn't come off.

**⚠ WARNING**  
**Make sure the fuel hose joint is installed correctly on the delivery pipe or the fuel could leak.**

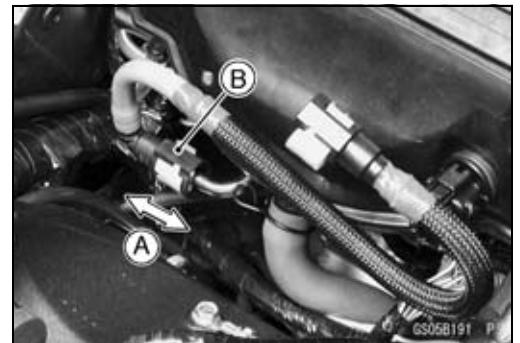

- ★ If it comes off, reinstall the hose joint.
- Run the fuel hose in accordance with the Cable, Wire and Hose Routing section in the Appendix chapter.
- Install the removed part.
- Start the engine and check the fuel hose for leaks.

## 2-46 PERIODIC MAINTENANCE

### Maintenance Procedure

#### Air Cleaner Element Replacement

##### NOTE

- In dusty areas, the element should be replaced more frequently than the recommended interval.
- After riding through rain or on muddy roads, the element should be replaced immediately.

##### ⚠ WARNING

If dirt or dust is allowed to pass through into the throttle assy, the throttle may become stuck, possibly causing an accident.

##### CAUTION

If dirt gets through into the engine, excessive engine wear and possibly engine damage will occur.

- Remove:
  - Seats (see Frame chapter)
  - Fuel Tank (see Fuel System (DFI) chapter)
  - Air Cleaner Element Cover Screws [A]
  - Air Cleaner Element Cover [B]
- Discard:
  - Air Cleaner Element
- Install a new element [A] so that the element ends [B] insert along the rib [C] in the housing.

##### CAUTION

Use only the recommended air cleaner element (Kawasaki part number 11013-0004). Using another air cleaner element will wear the engine prematurely or lower the engine performance.

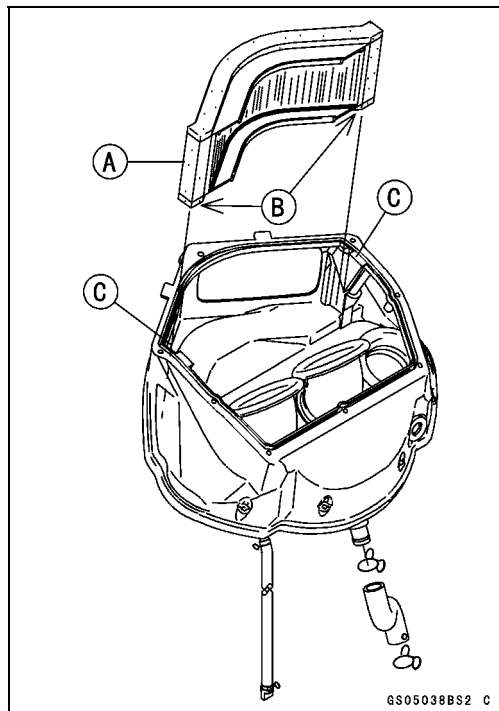
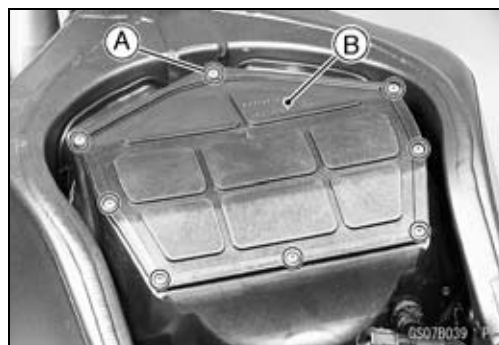

GS05038BS2 C

**Maintenance Procedure**

*Coolant Change*

**⚠ WARNING**

To avoid burns, do not remove the radiator cap or try to change the coolant when the engine is still hot. Wait until it cools down. Coolant on tires will make them slippery and can cause an accident and injury. Immediately wipe up or wash away any coolant that spills on the frame, engine, or other painted parts. Since coolant is harmful to the human body, do not use for drinking.

- Remove:
  - Right Middle Fairing (see Frame chapter)
  - Radiator Cap [A]
- Remove the radiator cap in two steps. First turn the cap counterclockwise to the first stop. Then push and turn it further in the same direction and remove the cap.



- Remove:
  - Left Lower Fairing (see Frame chapter)
  - Left Middle Fairing (see Frame chapter)
- Place a containers under the drain plugs [A] [B] at the bottom of the water pump cover and cylinder.
- Drain the coolant from the radiator and engine by removing the drain plugs.



- Remove:
  - Coolant Reserve Tank [A] (see Cooling System chapter)
- Remove the cap [B] and pour the coolant into a container.

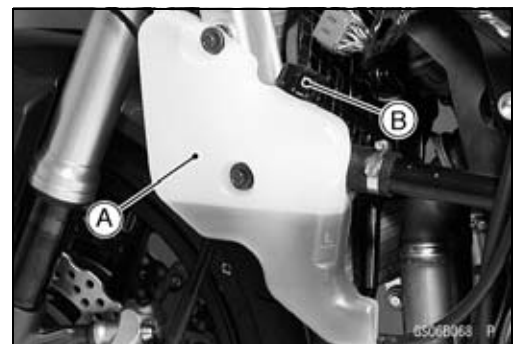

- Install the reserve tank (see Cooling System chapter).
- Tighten the drain plugs with the washers.
- Replace the drain plug gasket with a new one if it is damaged.

**Torque - Coolant Drain Plug (Water Pump): 9.8 N·m (1.0 kgf·m, 87 in·lb)**  
**Coolant Drain Plug (Cylinder): 9.8 N·m (1.0 kgf·m, 87 in·lb)**

## 2-48 PERIODIC MAINTENANCE

### Maintenance Procedure

- Fill the radiator up to the radiator filler neck [A] with coolant, and install the radiator cap.

#### NOTE

○ Pour in the coolant slowly so that it can expel the air from the engine and radiator.

- Fill the reserve tank up to the full level line with coolant, and install the cap.

#### CAUTION

**Soft or distilled water must be used with the antifreeze (see below for antifreeze) in the cooling system.**

**If hard water is used in the system, it causes scales accumulation in the water passages, and considerably reduces the efficiency of the cooling system.**

#### Water and Coolant Mixture Ratio (Recommended)

Soft Water:	50%
Coolant:	50%
Freezing Point:	-35°C (-31°F)
Total Amount:	2.5 L (2.6 US qt)

#### NOTE

○ Choose a suitable mixture ratio by referring to the coolant manufacturer's directions.

- Bleed the air from the cooling system as follows.
  - Start the engine with the radiator cap removed and run it until no more air bubbles [A] can be seen in the coolant.
  - Tap the radiator hoses to force any air bubbles caught inside.
  - Stop the engine and add coolant up to the radiator filler neck.
- Install the radiator cap.
- Start the engine, warm it up thoroughly until the radiator fan turns on and then stop the engine.
- Check the coolant level in the reserve tank after the engine cools down.
- ★ If the coolant level is lower than the low level line, add coolant to the full level line.

#### CAUTION

**Do not add more coolant above the full level line.**

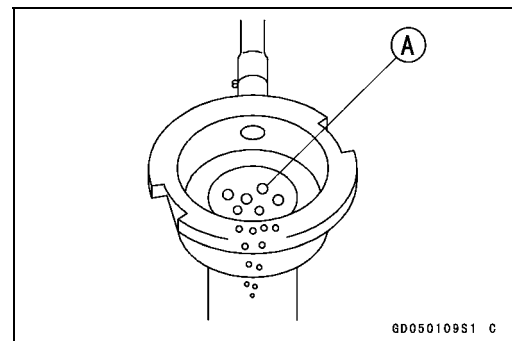
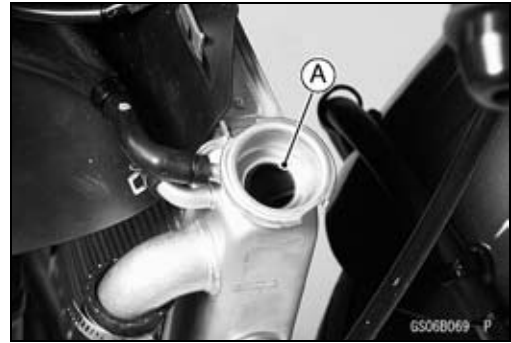



**Maintenance Procedure**

*Radiator Hose and O-ring Replacement*

- Drain the coolant (see Coolant Change).
- Remove:
  - Lower Fairings (see Frame chapter)
  - Middle Fairings (see Frame chapter)
  - Throttle Body Assy (see Fuel System (DFI) chapter)
  - Thermostat Housing [A]
  - Fitting [B]
  - Hoses [C]
  - O-rings [D]
- Apply grease to the new O-rings and install them.
- Instal the new hoses and tighten the clamps securely.
- Fill the coolant (see Coolant Change).
- Check the cooling system for leaks.

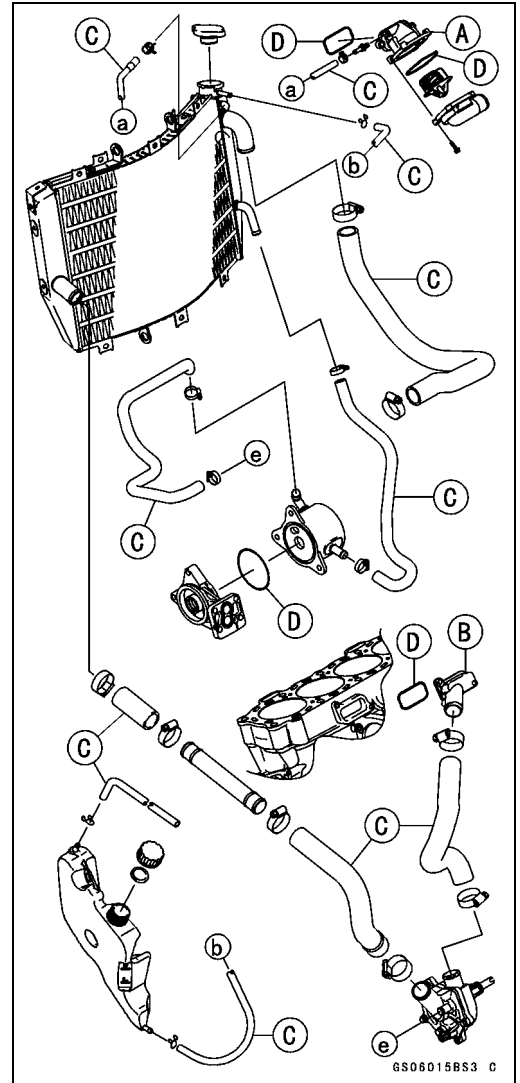

*Engine Oil Change*

- Situate the motorcycle so that it is vertical after warming up the engine.
- Remove the engine oil drain bolt [A] to drain the oil.
- The oil in the oil filter can be drained by removing the filter (see Oil Filter Replacement).
- ★ Replace the drain bolt gasket [B] with a new one.
- Tighten the drain bolt.
- Torque - Engine Oil Drain Bolt: 20 N·m (2.0 kgf·m, 14 ft·lb)**
- Pour in the specified type and amount of oil.

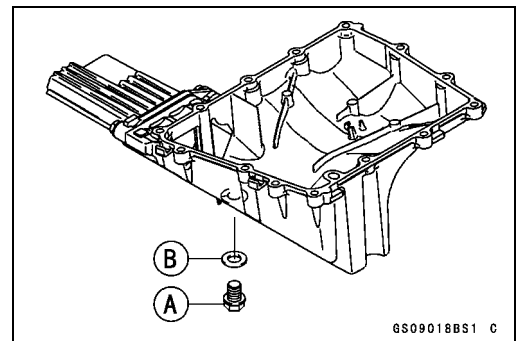

## 2-50 PERIODIC MAINTENANCE

### Maintenance Procedure

#### Recommended Engine Oil

- Type: API SE, SF or SG  
API SH or SJ with JASO MA
- Viscosity: SAE 10W-40
- Capacity: 2.7 L (2.9 US qt) (when filter is not removed)  
3.0 L (3.2 US qt) (when filter is removed)  
3.7 L (3.9 US qt) (when engine is completely dry)

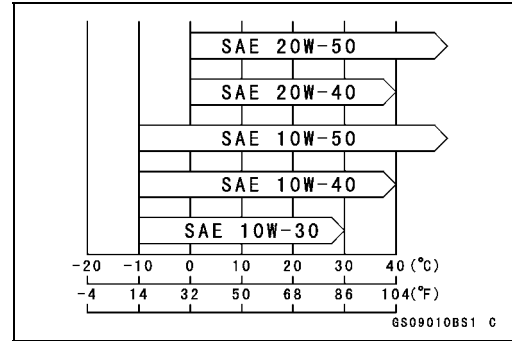

#### NOTE

- Although 10W-40 engine oil is the recommended oil for most conditions, the oil viscosity may need to be changed to accommodate atmospheric conditions in your riding area.

#### Oil Filter Replacement

- Drain the engine oil (see Engine Oil Change).
  - Remove:
    - Lower Fairing (see Frame chapter)
  - Remove the oil filter [A] with the oil filter wrench [B].
- Special Tool - Oil Filter Wrench: 57001-1249**

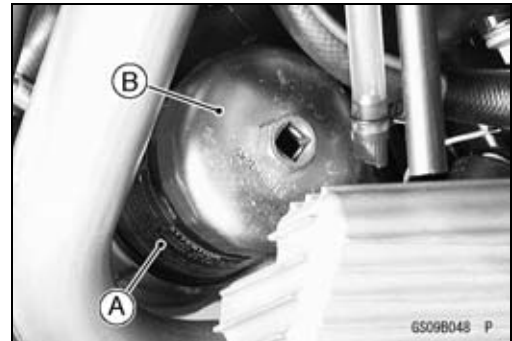

- Replace the filter with a new one.
- Apply engine oil to the gasket [A] before installation.
- Tighten the filter with the oil filter wrench.

**Torque - Oil Filter: 31 N·m (3.2 kgf·m, 23 ft·lb)**

#### NOTE

- Hand tightening of the oil filter can not be allowed since it does not reach to this tightening torque.

- Pour in the specified type and amount of oil (see Engine Oil Change).

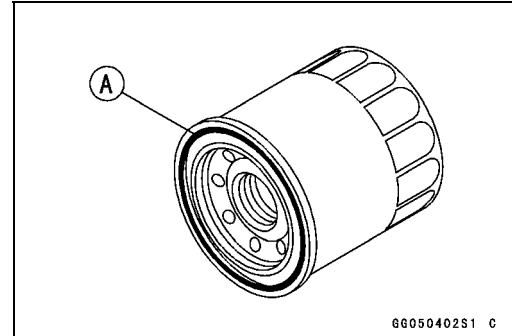

#### Brake Hose and Pipe Replacement

#### CAUTION

**Brake fluid quickly ruins painted plastic surfaces; any spilled fluid should be completely washed away immediately.**

- When removing the brake hose, take care not to spill the brake fluid on the painted or plastic parts.
- When removing the brake hose [A], temporarily secure the end of the brake hose to some high place to keep fluid loss to a minimum.
- Immediately wash away any brake fluid that spills.
- There are washers on each side of the brake hose fitting. Replace them with new ones when installing.
- Tighten:

**Torque - Brake Hose Banjo Bolts: 25 N·m (2.5 kgf·m, 18 ft·lb)**

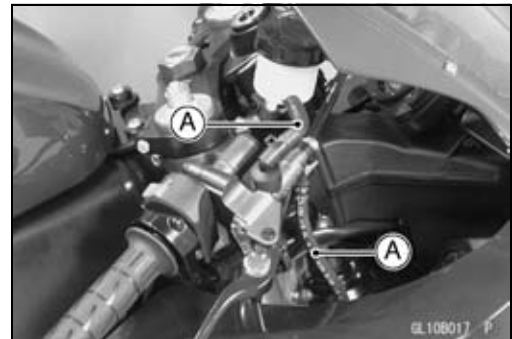

**Maintenance Procedure**

- When installing the hoses [A], avoid sharp bending, kinking, flattening or twisting, and route the hoses according to Cable, Wire, and Hose Routing section in Appendix chapter.
- Fill the brake line after installing the brake hose (see Brake Fluid Change).



*Brake Fluid Change*

**NOTE**

○The procedure to change the front brake fluid is as follows. Changing the rear brake fluid is the same as for the front brake.

- Level the brake fluid reservoir.
- Remove the reservoir cap.
- Remove the rubber cap from the bleed valve [A] on the caliper.
- Attach a clear plastic hose [B] to the bleed valve, and run the other end of the hose into a container.
- Fill the reservoir with fresh specified brake fluid.

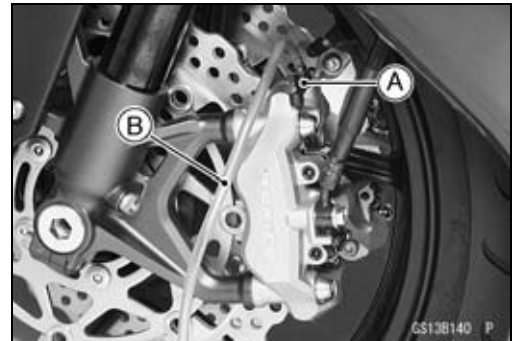

## 2-52 PERIODIC MAINTENANCE

### Maintenance Procedure

- Change the brake fluid.
- Repeat this operation until fresh brake fluid comes out from the plastic hose or the color of the fluid changes.
- 1. Open the bleed valve [A].
- 2. Apply the brake and hold it [B].
- 3. Close the bleed valve [C].
- 4. Release the brake [D].

#### NOTE

- The fluid level must be checked often during the changing operation and replenished with fresh brake fluid. If the fluid in the reservoir runs out any time during the changing operation, the brakes will need to be bled since air will have entered the brake line.
- Front Brake: Repeat the above steps for the other caliper.

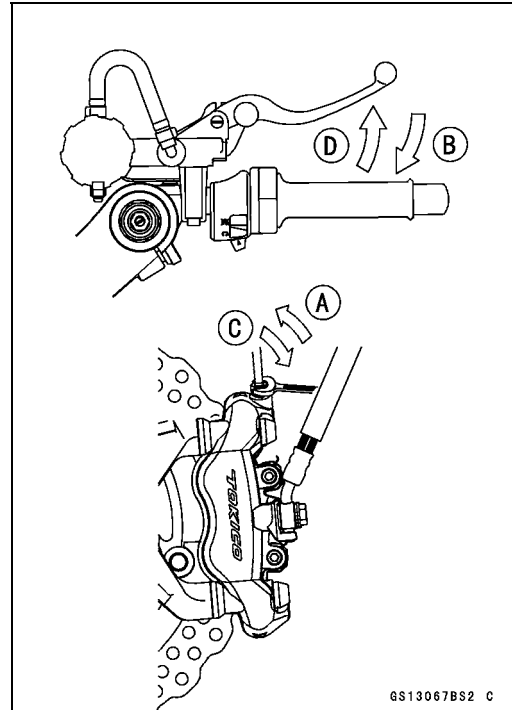

- Follow the procedure below to install the front/rear brake fluid reservoir cap correctly.
- First, tighten the front/rear brake fluid reservoir cap [B] clockwise [C] by hand until the resistance is felt fully; then, tighten the cap an additional 1/6 turn [D] while holding the brake fluid reservoir body [A].

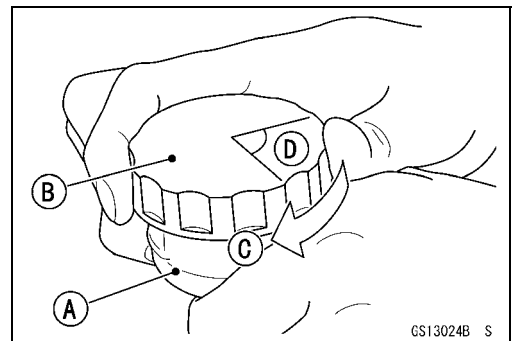

- Tighten:  
**Torque - Front Brake Reservoir Cap Stopper Screw: 1.2 N·m (0.12 kgf·m, 11 in·lb)**
- Tighten the bleed valve, and install the rubber cap.  
**Torque - Bleed Valve: 7.8 N·m (0.80 kgf·m, 69 in·lb)**
- After changing the fluid, check the brake for good braking power, no brake drag, and no fluid leakage.
- ★ If necessary, bleed the air from the lines.

**Maintenance Procedure**

**Master Cylinder Rubber Parts Replacement**

**Front Master Cylinder Disassembly**

- Remove the front master cylinder (see Brakes chapter).
- Remove the seal cover [A], circlip [B], connector [C] and O-ring [D].

**Special Tool - Inside Circlip Pliers: 57001-143**

- Unscrew the locknut [E] and pivot bolt [F], and remove the brake lever.
- Pull the dust cover [G] out of place, and remove the circlip [H].
- Pull out the piston assy [I] and return spring [J].
- Replace:
  - Seal Cover [A]
  - O-ring [D]
  - Dust Cover [G]
  - Piston Assy [I]
  - Diaphragm [K]

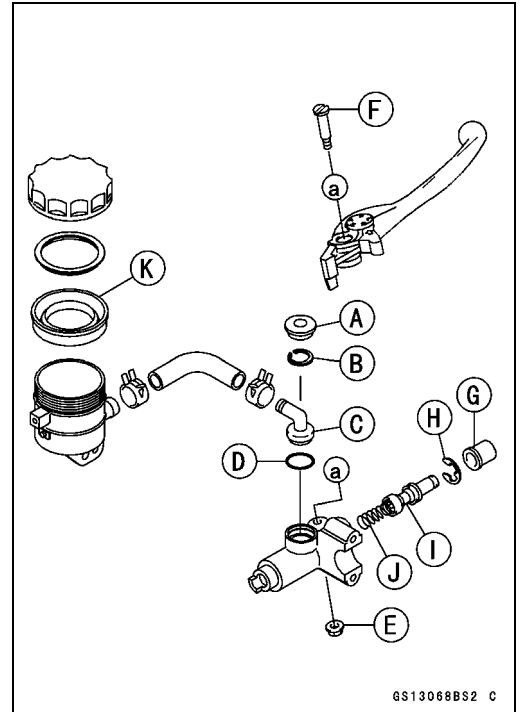

**Rear Master Cylinder Disassembly**

- Remove the rear master cylinder (see Brakes chapter).
- Remove the circlip [A], connector [B], and O-ring [C].
- Slide the dust cover [D] out of place, and remove the circlip [E].
- Pull out the push rod assy [F].
- Take off the piston assy [G] and return spring [H].
- Replace:
  - O-ring [C]
  - Push Rod Assy [F]
  - Piston Assy [G]
  - Diaphragm [I]

**Special Tool - Inside Circlip Pliers: 57001-143**

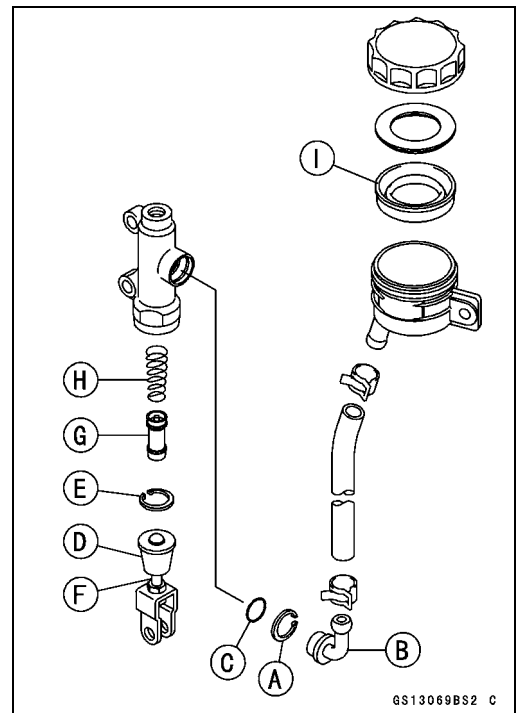

**Master Cylinder Assembly**

- Before assembly, clean all parts including the master cylinder with brake fluid or alcohol.

<b>CAUTION</b>
<p><b>Except for the disc pads and disc, use only disc brake fluid, isopropyl alcohol, or ethyl alcohol for cleaning brake parts. Do not use any other fluid for cleaning these parts. Gasoline, engine oil, or any other petroleum distillate will cause deterioration of the rubber parts. Oil spilled on any part will be difficult to wash off completely, and will eventually deteriorate the rubber used in the disc brake.</b></p>

## 2-54 PERIODIC MAINTENANCE

### Maintenance Procedure

- Apply brake fluid to the new parts and to the inner wall of the cylinder.
- Take care not to scratch the piston or the inner wall of the cylinder.

#### CAUTION

**Do not remove the secondary cup from the piston since removal will damage it.**

- Tighten the brake lever pivot bolt and the locknut.

#### Silicone Grease -

**Brake Lever Pivot Bolt, Brake Lever Pivot Contact, Piston Rod Contact, Dust Cover**

**Torque - Brake Lever Pivot Bolt: 1.0 N·m (0.10 kgf·m, 9 in·lb)**

**Brake Lever Pivot Bolt Locknut: 6.0 N·m (0.61 kgf·m, 53 in·lb)**

#### Caliper Rubber Parts Replacement

##### Front Caliper Disassembly

- Loosen the front caliper pad pins [A] and banjo bolt [B] and tighten them loosely.
- Remove:
  - Front Caliper (see Brakes chapter) [C]
  - Brake Pad
  - Front Caliper Assembly Bolts
  - O-rings

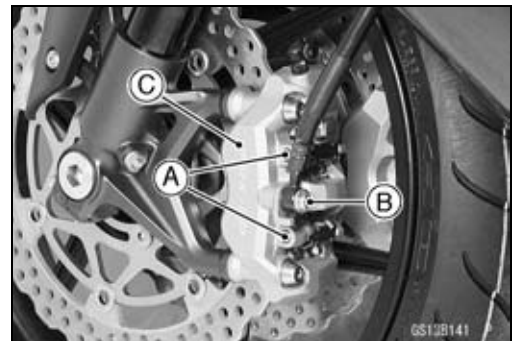

- Using compressed air, remove the pistons. One way to remove the pistons is as follows.
    - Install a rubber gasket [A] and a wooden board [B] more than 10 mm (0.4 in.) thick on the caliper half, and fasten them together with a suitable bolt and nut as shown. Leave one of the oil passages [C] open.
    - Lightly apply compressed air [D] to the oil passage until the pistons hit the rubber gasket. Block the hose joint opening [E] during this operation if the caliper half has the opening.
- [F] Bolt and Nut  
[G] Oil Passage Sealed by Rubber Gasket  
[H] Push down.

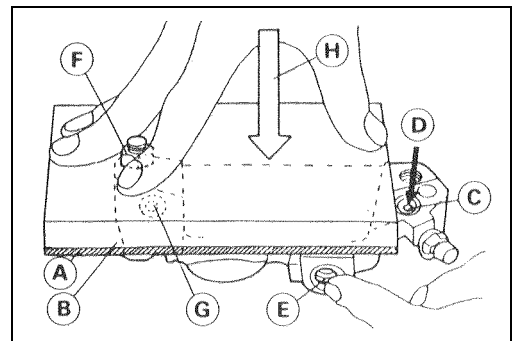

#### **⚠ WARNING**

**To avoid serious injury, never place your fingers or palm in front of the piston. If you apply compressed air into the caliper, the piston may crush your hand or fingers.**

- Pull out the pistons by hand.
- Remove the dust seals [A] and fluid seals [B].
- Remove the bleed valve [C] and rubber cap [D].
- Repeat the previous step to remove the pistons from the other side of the caliper body.

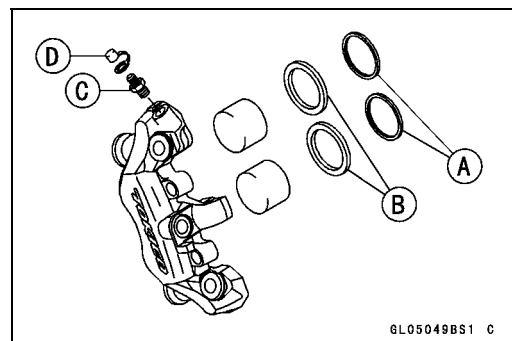

GL05049BS1 C

**Maintenance Procedure**

**NOTE**

- If compressed air is not available, do as follows for both calipers coincidentally, with the brake hose connected to the caliper.
- Prepare a container for brake fluid, and perform the work above it.
- Remove the spring and pads (see Brakes chapter).
- Pump the brake lever until the pistons come out of the cylinders, and then disassemble the caliper.

**Front Caliper Assembly**

- Clean the caliper parts except for the pads.

**CAUTION**

**For cleaning the parts, use only disc brake fluid, isopropyl alcohol, or ethyl alcohol.**

- Install the bleed valve and rubber cap.
- Torque - Bleed Valve: 7.8 N·m (0.80 kgf·m, 69 in·lb)**
- Replace the fluid seals [A] with new ones.
- Apply brake fluid to the fluid seals, and install them into the cylinders by hand.
- Replace the dust seals [B] with new ones if they are damaged.
- Apply brake fluid to the dust seals, and install them into the cylinders by hand.

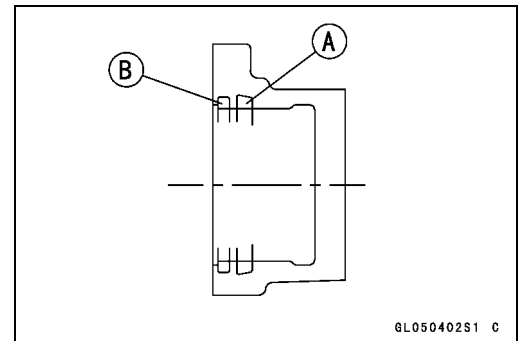

- Replace the O-ring [A].
- Apply brake fluid to the outside of the pistons, and push them into each cylinder by hand.
- Be sure to install the O-rings.
- Tighten:
- Torque - Front Caliper Assembly Bolts: 22 N·m (2.2 kgf·m, 16 ft·lb)**

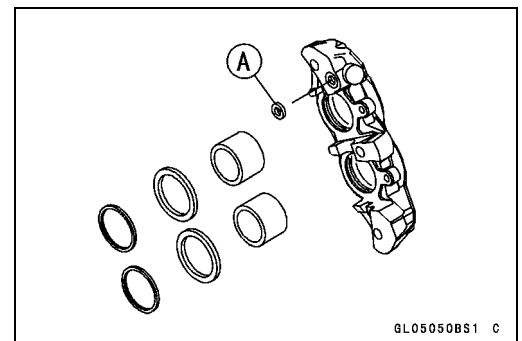

- Install the pads (see Brakes chapter).
- Wipe up any spilled brake fluid on the caliper with wet cloth.

## 2-56 PERIODIC MAINTENANCE

### Maintenance Procedure

#### Rear Caliper Disassembly

- Remove the rear caliper.
- Remove the pads and anti-rattle spring (see Brakes chapter).
- Using compressed air, remove the piston.
  - Cover the caliper opening with a clean, heavy cloth [A].
  - Remove the piston by lightly applying compressed air [B] to where the brake line fits into the caliper.

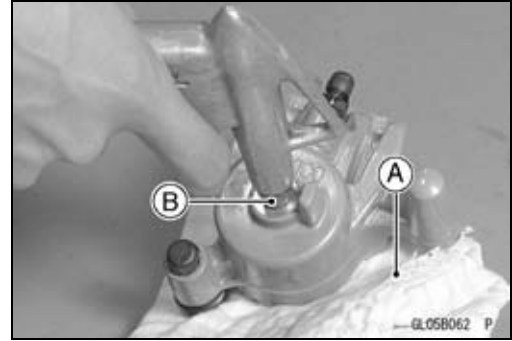

#### **⚠ WARNING**

**To avoid serious injury, never place your fingers or palm inside the caliper opening. If you apply compressed air into the caliper, the piston may crush your hand or fingers.**

- Remove the dust seal and fluid seal.
- Remove the bleed valve and rubber cap.

#### **NOTE**

- If compressed air is not available, do as follows with the brake hose connected to the caliper.
- Prepare a container for brake fluid, and perform the work above it.
- Remove the pads and spring (see Brakes chapter).
- Pump the brake pedal to remove the caliper piston.

#### Rear Caliper Assembly

- Clean the caliper parts except for the pads.

#### **CAUTION**

**For cleaning of the parts, use only disc brake fluid, isopropyl alcohol, or ethyl alcohol.**

- Install the bleed valve and rubber cap.  
**Torque - Bleed Valve: 7.8 N·m (0.80 kgf·m, 69 in·lb)**

- Replace the fluid seal [A] with a new one.
  - Apply brake fluid to the fluid seal, and install it into the cylinder by hand.
- Replace the dust seal [B] with a new one.
  - Apply brake fluid to the dust seal, and install it into the cylinder by hand.

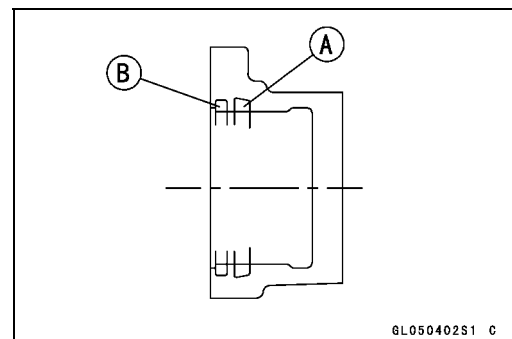



**Maintenance Procedure**

- Apply brake fluid to the outside of the piston, and push it into the cylinder by hand.
- Replace the shaft rubber friction boot [A] and dust boot [B].
- Apply a thin coat of PBC (Poly Butyl Cuprysil) grease to the caliper holder shafts [C] and holder holes [D] (PBC is a special high temperature, water-resistance grease).

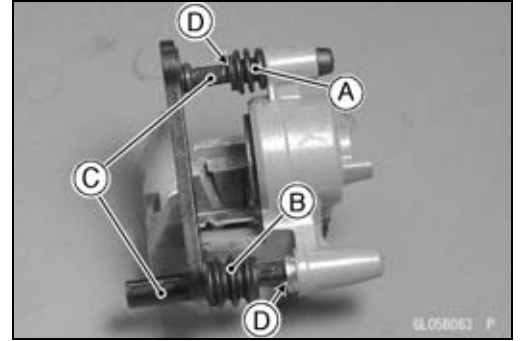

- Install the anti-rattle spring [A] in the caliper as shown.
- Install the pads (see Rear Brake chapter).
- Wipe up any spilled brake fluid on the caliper with wet cloth.

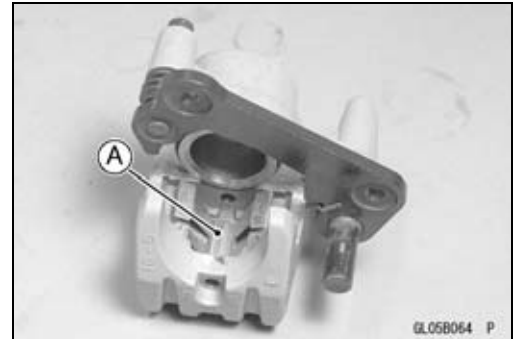

**Spark Plug Replacement**

- Remove:
  - Stick Coils (see Electrical System chapter)
- Remove the spark plug using the 16 mm (0.63 in.) plug wrench [A] vertically.



- Insert new spark plug in the plug hole, and finger-tighten it first.
- Using the plug wrench [A] vertically, tighten the plug.



**CAUTION**

**The insulator of the spark plug may break if when the wrench is inclined during tightening.**

**Torque - Spark Plugs: 13 N·m (1.3 kgf·m, 113 in·lb)**

- Install the stick coils securely.
- Be sure the stick coils are installed by pulling up it lightly.



# Fuel System (DFI)

## Table of Contents

Exploded View.....	3-3	Crankshaft Sensor (Service Code 21).....	3-63
Specifications .....	3-10	Crankshaft Sensor Removal/Installation.....	3-63
Special Tools and Sealant.....	3-12	Crankshaft Sensor Inspection.....	3-63
DFI Parts Location.....	3-14	Camshaft Position Sensor (Service Code 23).....	3-64
DFI System.....	3-16	Camshaft Position Sensor Removal/Installation.....	3-64
DFI Servicing Precautions.....	3-20	Camshaft Position Sensor Inspection.....	3-64
Troubleshooting the DFI System.....	3-22	Speed Sensor (Service Code 24).....	3-65
Outline .....	3-22	Speed Sensor Removal/Installation .....	3-65
Inquiries to Rider.....	3-26	Speed Sensor Inspection.....	3-65
DFI System Troubleshooting Guide ..	3-29	Input Voltage Inspection.....	3-65
Self-Diagnosis .....	3-37	Output Voltage Inspection.....	3-65
Self-diagnosis Outline.....	3-37	Gear Position Switch (Service Code 25).....	3-67
Self-diagnosis Procedures.....	3-37	Gear Position Switch Removal/Installation.....	3-67
Service Code Reading.....	3-38	Gear Position Switch Inspection ..	3-67
Service Code Erasing .....	3-39	Input Voltage Inspection.....	3-67
Backups .....	3-41	Vehicle-down-sensor (Service Code 31).....	3-69
Main Throttle Sensor (Service Code 11).....	3-44	Removal.....	3-69
Main Throttle Sensor Removal/Adjustment.....	3-44	Installation.....	3-69
Input Voltage Inspection.....	3-44	Inspection.....	3-69
Output Voltage Inspection.....	3-45	Subthrottle Sensor (Service Code 32).....	3-72
Resistance Inspection.....	3-48	Subthrottle Sensor Removal/Adjustment.....	3-72
Inlet Air Pressure Sensor (Service Code 12).....	3-49	Input Voltage Inspection.....	3-72
Removal.....	3-49	Output Voltage Inspection.....	3-73
Installation.....	3-49	Resistance Inspection.....	3-75
Input Voltage Inspection.....	3-49	Exhaust Butterfly Valve Actuator Sensor (Service Code 34) .....	3-76
Output Voltage Inspection.....	3-50	Exhaust Butterfly Valve Actuator Sensor Inspection .....	3-76
Inlet Air Temperature Sensor (Service Code 13).....	3-54	Immobilizer Amplifier (Service Code 35).....	3-77
Removal/Installation.....	3-54	Antenna Resistance Inspection ..	3-77
Output Voltage Inspection.....	3-54	Amplifier Input Voltage Inspection ..	3-77
Sensor Resistance Inspection .....	3-55	Blank Key Detection (Service Code 36).....	3-78
Water Temperature Sensor (Service Code 14).....	3-57	User Key Inspection.....	3-78
Removal/Installation.....	3-57		
Output Voltage Inspection.....	3-57		
Sensor Resistance Inspection .....	3-58		
Atmospheric Pressure Sensor (Service Code 15).....	3-59		
Removal.....	3-59		
Installation.....	3-59		
Input Voltage Inspection.....	3-59		
Output Voltage Inspection.....	3-60		

## 3-2 FUEL SYSTEM (DFI)

Fuel Injectors #1, #2, #3, #4: (Service Code 41, 42, 43, 44).....	3-79	Fuel Line.....	3-101
Power Source Voltage Inspection	3-79	Fuel Pressure Inspection .....	3-101
Output Voltage Inspection.....	3-80	Fuel Flow Rate Inspection .....	3-102
Audible Inspection.....	3-82	Fuel Pump .....	3-104
Injector Signal Test.....	3-82	Fuel Pump Removal .....	3-104
Injector Resistance Inspection .....	3-83	Fuel Pump Installation .....	3-104
Injector Unit Test .....	3-83	Operation Inspection.....	3-105
Injector Fuel Line Inspection .....	3-84	Operating Voltage Inspection.....	3-105
Fuel Pump Relay (Service Code 45, 46).....	3-86	Throttle Grip and Cables .....	3-107
Fuel Pump Relay Removal .....	3-86	Free Play Inspection .....	3-107
Fuel Pump Relay Inspection .....	3-86	Free Play Adjustment.....	3-107
Stick Coils #1, #2, #3, #4: (Service Code 51, 52, 53, 54).....	3-88	Cable Installation .....	3-107
Removal/Installation.....	3-88	Cable Lubrication .....	3-107
Input Voltage Inspection.....	3-88	Throttle Body Assy .....	3-108
Subthrottle Valve Actuator (Service Code 62).....	3-90	Idle Speed Inspection .....	3-108
Subthrottle Valve Actuator Removal .....	3-90	Throttle Bore Cleaning .....	3-108
Subthrottle Valve Actuator Inspection.....	3-90	Synchronization Inspection.....	3-108
Resistance Inspection.....	3-90	Synchronization Adjustment .....	3-108
Exhaust Butterfly Valve Actuator (Service Code 63).....	3-92	Throttle Body Assy Removal.....	3-108
Exhaust Butterfly Valve Actuator Removal .....	3-92	Throttle Body Assy Installation....	3-109
Exhaust Butterfly Valve Actuator Installation .....	3-92	Throttle Body Assy Disassembly .	3-110
Exhaust Butterfly Valve Actuator Inspection.....	3-93	Throttle Body Assy Assembly .....	3-111
Output Voltage Inspection .....	3-94	Air Line .....	3-112
ECU Main Relay (Service Code 75) ..	3-95	Element Removal.....	3-112
ECU Main Relay Removal .....	3-95	Element Installation.....	3-112
ECU Main Relay Inspection .....	3-95	Air Cleaner Element Inspection ...	3-112
ECU .....	3-96	Air Cleaner Housing Removal.....	3-112
ECU Identification .....	3-96	Air Cleaner Housing Installation...	3-113
ECU Removal .....	3-96	Air Cleaner Housing Disassembly	3-114
ECU Installation .....	3-97	Air Cleaner Housing Assembly ....	3-114
ECU Power Supply Inspection.....	3-97	Oil Draining .....	3-114
DFI Power Source .....	3-99	Air Inlet Duct Removal .....	3-115
ECU Fuse Removal .....	3-99	Air Inlet Duct Installation .....	3-115
ECU Fuse Installation .....	3-99	Fuel Tank.....	3-116
ECU Fuse Inspection .....	3-99	Fuel Tank Removal .....	3-116
FI Indicator LED Light.....	3-100	Fuel Tank Installation .....	3-118
LED Light Inspection.....	3-100	Fuel Tank and Cap Inspection .....	3-119
		Fuel Tank Cleaning .....	3-119
		Evaporative Emission Control System.....	3-120
		Parts Removal/Installation .....	3-120
		Hose Inspection .....	3-120
		Separator Inspection.....	3-120
		Separator Operation Test.....	3-121
		Canister Inspection (California Model Only).....	3-121

---

**Exploded View**

---

Dummy Page

# 3-4 FUEL SYSTEM (DFI)

## Exploded View

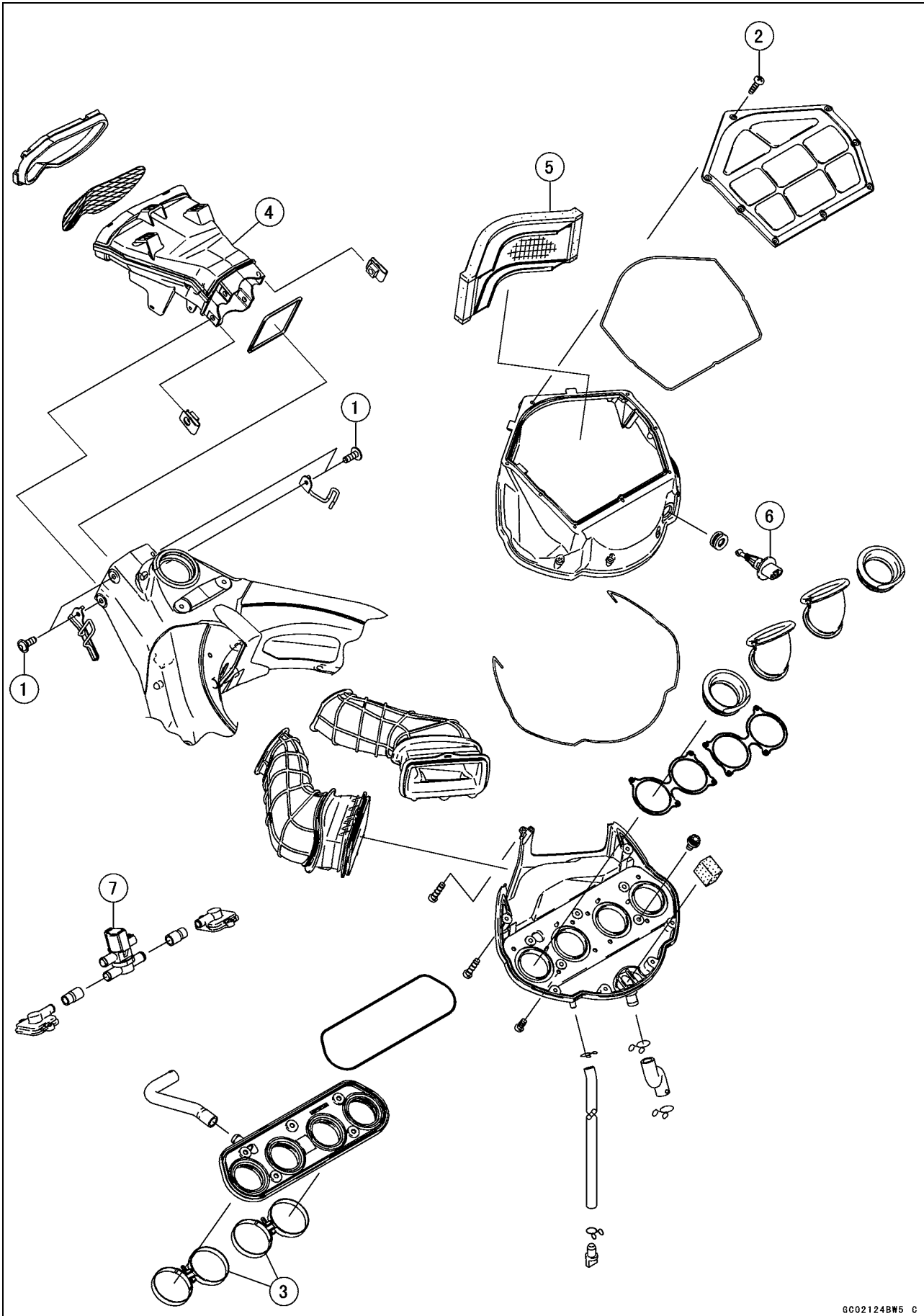

**Exploded View**

No.	Fastener	Torque			Remarks
		N·m	kgf·m	ft·lb	
1	Air Inlet Duct Mounting Bolts	7.0	0.70	62 in·lb	
2	Air Cleaner Element Cover Screws	1.1	0.11	9.7 in·lb	
3	Air Cleaner Housing Holder Clamp Screws	4.9	0.50	43 in·lb	

- 4. Air Inlet Duct
- 5. Air Cleaner Element
- 6. Inlet Air Temperature Sensor
- 7. Air Switching Valve





**Exploded View**

No.	Fastener	Torque			Remarks
		N·m	kgf·m	ft·lb	
1	Camshaft Position Sensor Bolt	9.8	1.0	87 in·lb	
2	Water Temperature Sensor	25	2.5	18	
3	Vehicle-down-Sensor Bolts	6.0	0.60	53 in·lb	
4	Gear Position Switch Screws	4.9	0.50	43 in·lb	L
5	Speed Sensor Bolt	4.0	0.40	35 in·lb	L
6	Crankshaft Sensor Bolts	6.0	0.60	53 in·lb	
7	Delivery Pipe Mounting Screws	4.9	0.50	43 in·lb	
8	Throttle Body Assembly Holder Clamp Bolts	2.0	0.20	18 in·lb	
9	Throttle Body Holder Bolts	9.8	1.0	87 in·lb	
10	Inlet Air Pressure Sensor Screw	3.5	0.36	31 in·lb	

- 11. Throttle Cable (Accelerator)
- 12. Throttle Cable (Decelerator)
- 13. Relay Box
- 14. ECU
- 15. Atmospheric Pressure Sensor
- 16. Inlet Air Pressure Sensor
- 17. Subthrottle Valve Actuator
- 18. Subthrottle Valve Sensor
- 19. Main throttle Valve Sensor
- 20. Bypass Screw
- 21. Injector
- 22. Stick Coil
- CL: Apply cable lubricant.
- EO: Apply engine oil.
- G: Apply grease.
- L: Apply a non-permanent locking agent.
- R: Replacement Parts
- SS: Apply silicone sealant (Kawasaki Bond: 56019-120).



**Exploded View**

No.	Fastener	Torque			Remarks
		N·m	kgf·m	ft·lb	
1	Exhaust Butterfly Valve Actuator Mounting Nuts	7.0	0.70	62 in·lb	
2	Exhaust Butterfly Valve Actuator Pulley Bolt	4.9	0.50	43 in·lb	
3	Exhaust Butterfly Valve Cover Bolts	8.8	0.90	78 in·lb	
4	Fuel Pump Bolts	9.8	1.0	87 in·lb	L, S
5	Separator Mounting Bolt	11	1.1	97 in·lb	

6. Canister

7. Separator

8. Fitting

9. Red Tube

10. Blue Tube

11. Green Tube

12. White Tube

L: Apply a non-permanent locking agent.

R: Replacement Parts

S: Follow the specific tightening sequence.

CAL: California Model

### 3-10 FUEL SYSTEM (DFI)

#### Specifications

Item	Standard
<b>Digital Fuel Injection System</b>	
Idle Speed	1 100 ±50 r/min (rpm)
Throttle Assy:	
Type	Four barrel type
Bore	φ43 mm (1.7 in.)
Throttle Body Vacuum	30 ±1.3 kPa (225 ±10 mmHg)
Bypass Screws	— — —
ECU (Electronic Control Unit):	
Make	Mitsubishi Electric
Type	Digital memory type, with built in IC igniter, sealed with resin
Usable Engine Speed	100 ~ 15 000 r/min (rpm)
Fuel Pressure (high pressure line):	
Right after Ignition SW ON, with fuel pump running for 4 seconds with engine idling	304 kPa (3.1 kgf/cm <sup>2</sup> , 44 psi) with fuel pump running 280 kPa (2.9 kgf/cm <sup>2</sup> , 41 psi) with fuel pump stopped 304 kPa (3.1 kgf/cm <sup>2</sup> , 44 psi) with fuel pump running
Fuel Pump:	
Type	In-tank pump (in fuel tank), or Wesco pump (friction pump)
Discharge	72 mL (2.43 US oz) or more for 4 seconds
Fuel Injectors:	
Type	INP-284
Nozzle Type	One spray type with 12 holes
Resistance	about 11.7 ~ 12.3 Ω at 20°C (68°F)
Main Throttle Sensor:	Non-adjustable and non-removable
Input Voltage	4.75 ~ 5.25 V DC between BL and BR/BK leads
Output Voltage	0.66 ~ 4.62 V DC between Y/W and BR/BK leads (at idle throttle opening to full throttle opening)
Resistance	4 ~ 6 kΩ
Inlet Air Pressure Sensor/Atmospheric Pressure Sensor:	
Input Voltage	4.75 ~ 5.25 V DC between BL and BR/BK leads
Output Voltage	3.80 ~ 4.20 V DC at standard atmospheric pressure (see this text for details)
Inlet Air Temperature Sensor:	
Resistance	2.09 ~ 2.81 kΩ at 20°C (68°F) about 0.322 kΩ at 80°C (176°F)
Output Voltage at ECU	about 2.25 ~ 2.50 V @20°C (68°F)
Water Temperature Sensor:	
Resistance	see Electrical System chapter
Output Voltage at ECU	about 2.80 ~ 2.97 V @20°C (68°F)
Speed Sensor:	
Input Voltage at Sensor	about 9 ~ 11 V DC at Ignition SW ON
Output Voltage at Sensor	about 0.05 ~ 0.07 V DC at Ignition SW ON and 0 km/h

**Specifications**

Item	Standard
Vehicle-down-Sensor: Detection Method Detection Angle Detection Time Output Voltage	Magnetic flux detection method More than 60 ~ 70° for each bank Within 1.0 ~ 1.5 sec. with sensor arrow mark pointed up: 3.55 ~ 4.45 V with sensor tilted 60 ~ 70° or more: 0.65 ~ 1.35 V
Subthrottle Sensor: Input Voltage Output Voltage  Resistance	Non-adjustable and non-removal 4.75 ~ 5.25 V DC between BL and BR/BK leads 0.88 ~ 4.35 V DC between BL/W and BR/BK leads (at idle throttle opening to full throttle opening) 4 ~ 6 kΩ
Exhaust Butterfly Valve Actuator Sensor: Resistance	4 ~ 6 kΩ
Immobilizer Amplifier: Antenna Resistance	about 0.6 ~ 0.9 Ω
Exhaust Butterfly Valve Actuator: Output Voltage	3.46 ~ 3.76 V
Subthrottle Valve Actuator: Resistance	reference 5 ~ 30 Ω
<b>Throttle Grip and Cables</b> Throttle Grip Free Play	2 ~ 3 mm (0.08 ~ 0.12 in.)

# 3-12 FUEL SYSTEM (DFI)

## Special Tools and Sealant

**Oil Pressure Gauge, 5 kgf/cm<sup>2</sup>:**  
57001-125

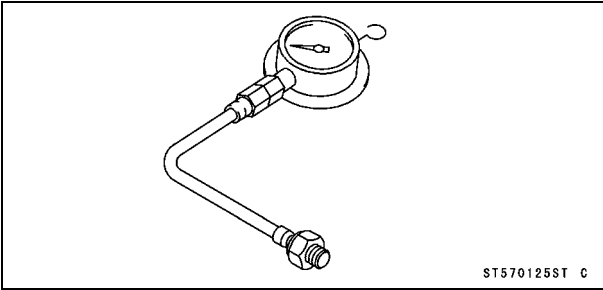

**Throttle Sensor Setting Adapter:**  
57001-1521

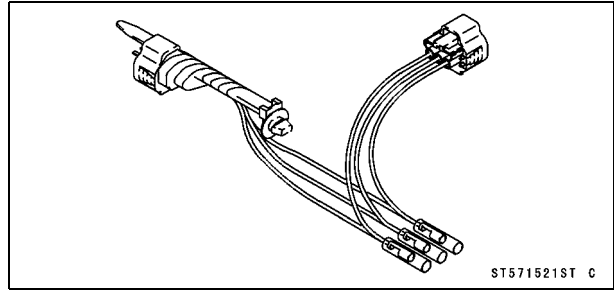

**Fork Oil Level Gauge:**  
57001-1290

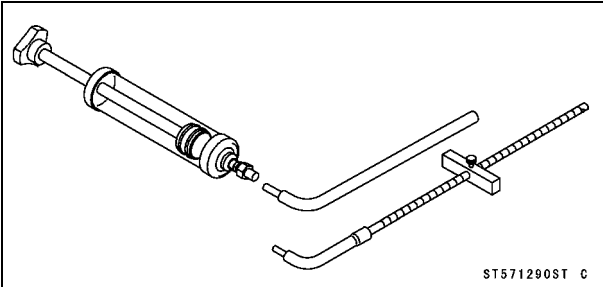

**Sensor Harness Adapter:**  
57001-1561

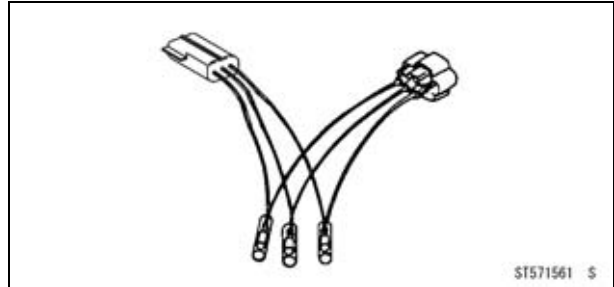

**Hand Tester:**  
57001-1394

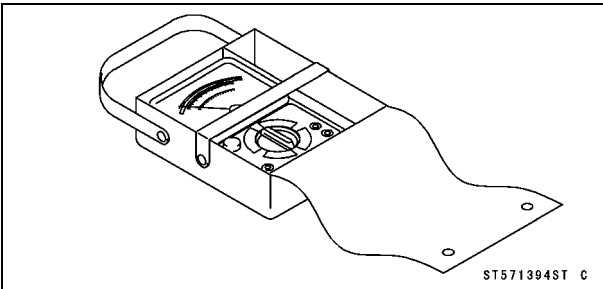

**Pilot Screw Adjuster, D:**  
57001-1588

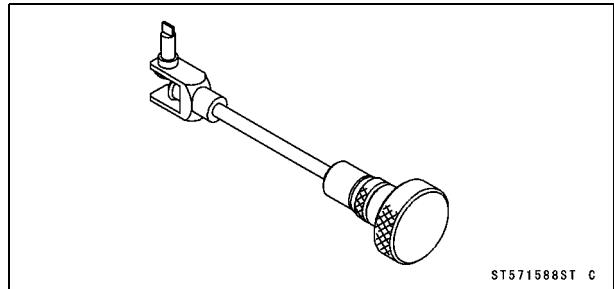

**Throttle Sensor Setting Adapter #1:**  
57001-1400

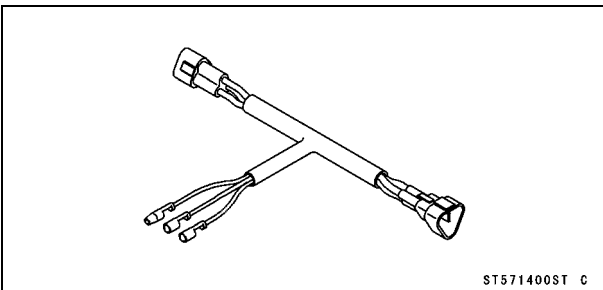

**Fuel Pressure Gauge Adapter:**  
57001-1593

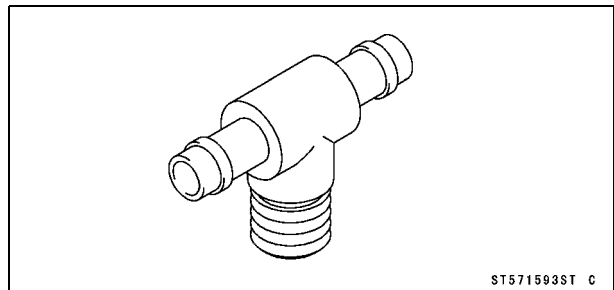

**Needle Adapter Set:**  
57001-1457

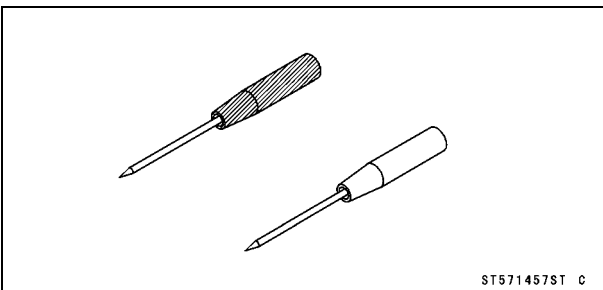

**Fuel Hose:**  
57001-1607

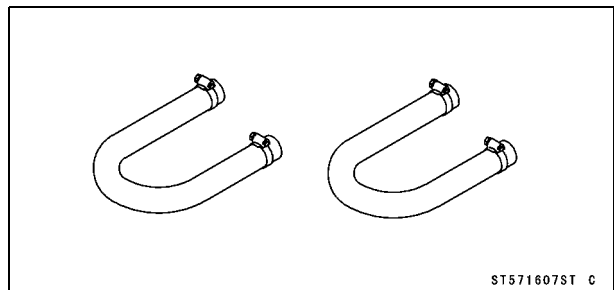

---

**Special Tools and Sealant**

---

**Kawasaki Bond (Silicone Sealant):**  
**56019-120**

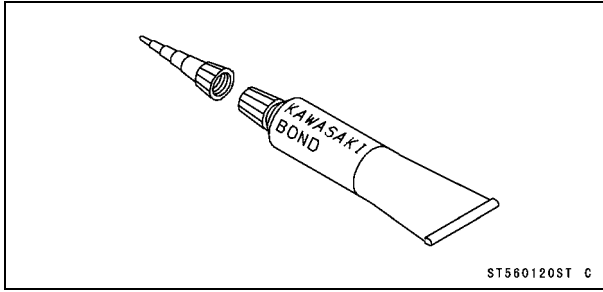

## 3-14 FUEL SYSTEM (DFI)

### DFI Parts Location

Subthrottle Sensor [A]  
Subthrottle Valve Actuator [B]  
Fuel Injectors #1, #2, #3, #4 [C]

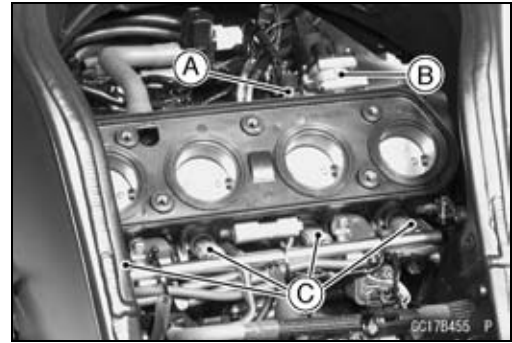

Water Temperature Sensor [A]  
Main Throttle Sensor [B]  
Inlet Air Pressure Sensor [C]  
Stick Coils #1, #2, #3, #4 [D]  
Subthrottle Valve Actuator [E]  
Subthrottle Sensor [F]

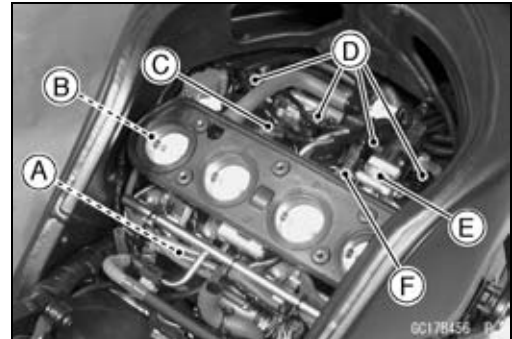

Battery [A]  
Relay Box [B]  
Exhaust Butterfly Valve Actuator [C]  
ECU (Electronic Control Unit) [D]

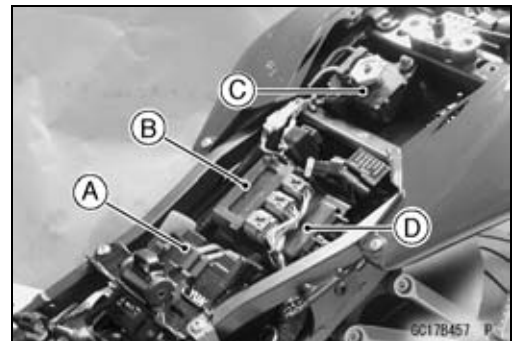

Self-diagnosis Terminal [A]  
Kawasaki Diagnosis System Connector [B]  
Atmospheric Pressure Sensor [C]  
Vehicle-down-Sensor [D]

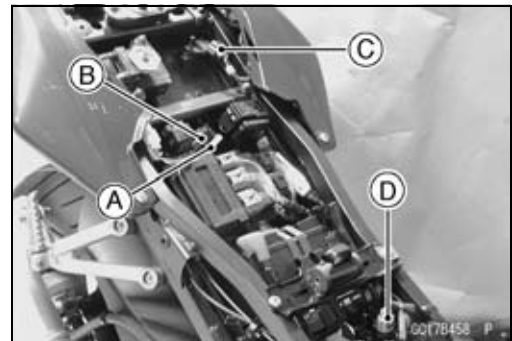

Inlet Air Temperature Sensor [A]





## DFI Parts Location

Camshaft Position Sensor [A]  
Crankshaft Sensor [B]

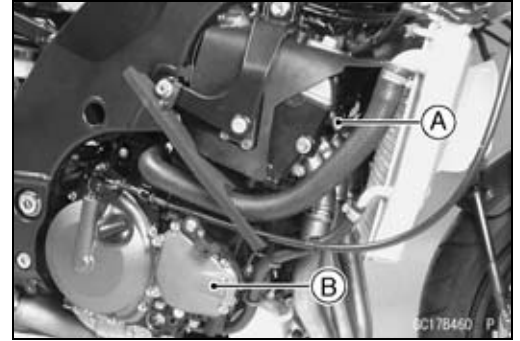

Speed Sensor [A]  
Gear Position Switch [B]

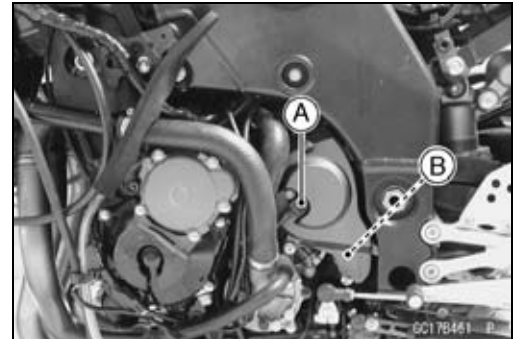

Gear Position Switch [A]



Ignition Key [A] (Transponder)  
Ignition Switch [B]  
Immobilizer Antenna [C]  
Immobilizer Amplifier [D]

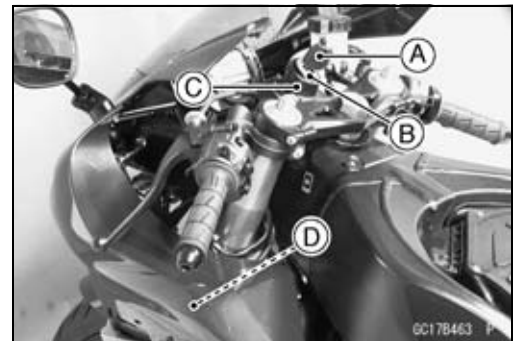

Immobilizer Amplifier [A]  
(Headlight [B])

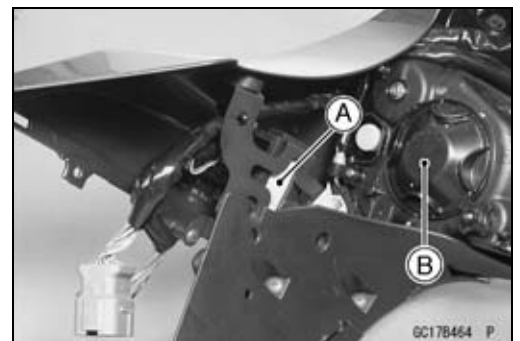

# 3-16 FUEL SYSTEM (DFI)

## DFI System

### DFI System Wiring Diagram

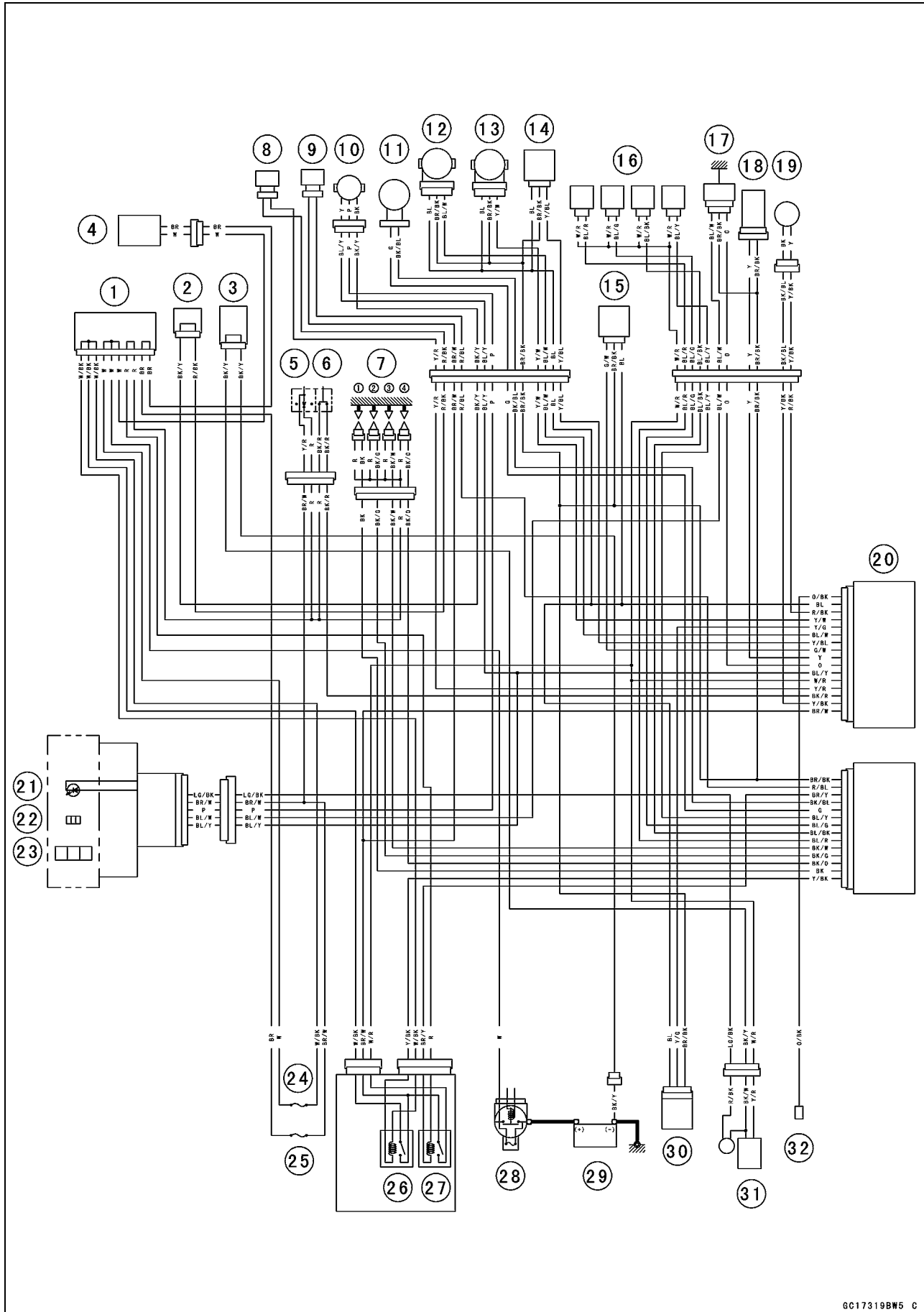

---

**DFI System**

---

**Part Name**

1. Joint Connector 4
2. Joint Connector 1
3. Joint Connector 2
4. Ignition Switch
5. Engine Stop Switch
6. Starter Button
7. Stick Coil #1, #2, #3, #4
8. Camshaft Position Sensor
9. Air Switching Valve
10. Speed Sensor
11. Subthrottle Valve Actuator
12. Subthrottle Sensor
13. Main Throttle Sensor
14. Inlet Air Pressure Sensor
15. Atmospheric Pressure Sensor
16. Injector #1, #2, #3, #4
17. Water Temperature Sensor
18. Inlet Air Temperature Sensor
19. Crankshaft Sensor
20. ECU (Electronic Control Unit)
21. FI Warning Indicator LED
22. Water Temperature Gauge
23. Speedometer
24. ECU Fuse 15A
25. Ignition Fuse 10 A
26. ECU Main Relay
27. Fuel Pump Relay
28. Main Fuse 30 A
29. Battery
30. Vehicle-down- Sensor
31. Fuel Pump
32. Self-diagnosis Terminal

## 3-18 FUEL SYSTEM (DFI)

### DFI System

#### Terminal Numbers of ECU Connectors

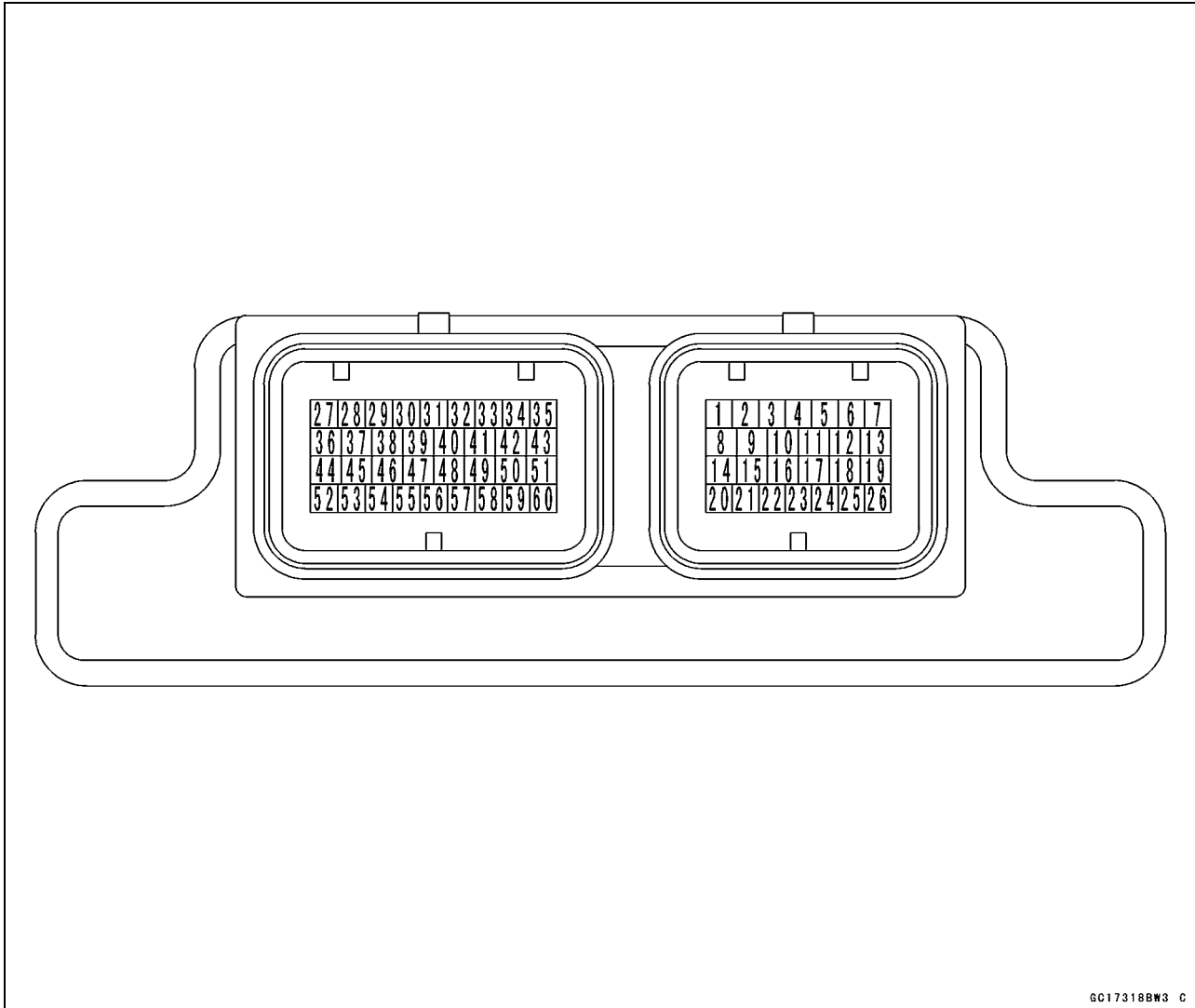

GC17318BW3 C

#### Terminal Names

1. External Communication Line
2. Side Stand Switch
3. Crankshaft Sensor (-)
4. Vehicle-down-Sensor
5. Main Throttle Sensor
6. Subthrottle Sensor
7. Exhaust Butterfly Valve Sensor
8. Engine Stop Switch
9. -
10. Camshaft Position Sensor
11. Inlet Air Temperature Sensor
12. Gear Position Switch
13. Water Temperature Sensor
14. External Communication Line
15. Crankshaft Sensor (+)
16. Speed Sensor
17. Inlet Air Pressure Sensor
18. Atmospheric Pressure Sensor
19. Starter Button
20. Power Supply to ECU (from Battery)
21. Battery Monitor
22. Clutch Switch
23. Power Supply to Sensors

**DFI System**

---

24. Ignition Switch
25. External Communication Line (Mode Switch)
26. Self-diagnosis Terminal
27. Stick Coil #4
28. Stick Coil #1
29. Injector #1
30. Exhaust Butterfly Valve Actuator (+)
31. Exhaust Butterfly Valve Actuator (-)
32. -
33. Air Switching Valve
34. Subthrottle Valve Actuator (+)
35. Subthrottle Valve Actuator (-)
36. Injector #2
37. Immobilizer Communication Line
38. Immobilizer Communication Line
39. -
40. -
41. -
42. -
43. FI Indicator LED
44. -
45. Immobilizer Communication Line
46. -
47. Main Relay
48. External Communication Line
49. Tachometer
50. Ground
51. Ground
52. Stick Coil #3
53. Stick Coil #2
54. Injector #3
55. -
56. Injector #4
57. Radiator Fan Relay
58. Fuel Pump Relay
59. Ground for Sensors
60. Ground for Control

## 3-20 FUEL SYSTEM (DFI)

### DFI Servicing Precautions

---

There are a number of important precautions that should be followed servicing the DFI system.

- This DFI system is designed to be used with a 12 V sealed battery as its power source. Do not use any other battery except for a 12 V sealed battery as a power source.
- Do not reverse the battery cable connections. This will damage the ECU.
- To prevent damage to the DFI parts, do not disconnect the battery cables or any other electrical connections when the ignition SW (switch) is on, or while the engine is running.
- Take care not to short the leads that are directly connected to the battery positive (+) terminal to the chassis ground.
- When charging, remove the battery from the motorcycle. This is to prevent ECU damage by excessive voltage.
- Whenever the DFI electrical connections are to be disconnected, first turn off the ignition SW (switch). Conversely, make sure that all the DFI electrical connections are firmly reconnected before starting the engine.
- Do not turn the ignition SW ON while any of the DFI electrical connectors are disconnected. The ECU memorizes service codes.
- Do not spray water on the electrical parts, DFI parts, connectors, leads, and wiring.
- If a transceiver is installed on the motorcycle, make sure that the operation of the DFI system is not influenced by electric wave radiated from the antenna. Check operation of the system with the engine at idle. Locate the antenna as far as possible away from the ECU.
- When any fuel hose is disconnected, do not turn on the ignition SW. Otherwise, the fuel pump will operate and fuel will spout from the fuel hose.
- Do not operate the fuel pump if the pump is completely dry. This is to prevent pump seizure.
- Before removing the fuel system parts, blow the outer surfaces of these parts clean with compressed air.
- When any fuel hose is disconnected, fuel may spout out by residual pressure in the fuel line. Cover the hose joint with a piece of clean cloth to prevent fuel spillage.
- When installing the fuel hoses, avoid sharp bending, kinking, flattening or twisting, and route the fuel hoses with a minimum of bending so that the fuel flow will not be obstructed.
- Route the hoses according to Cable, Wire, and Hose Routing section in the General Information chapter.
- To prevent corrosion and deposits in the fuel system, do not add to fuel any fuel antifreeze chemicals.
- Replace the fuel hose if it has been sharply bent or kinked.

### DFI Servicing Precautions

- The fuel hose [A] is designed to be used through out the motorcycle's life without any maintenance, however, if the motorcycle is not properly handled, the high pressure inside the fuel line can cause fuel to leak or the hose to burst. Bend and twist the fuel hose while examining it.
- ★Replace the hose if any cracks or bulges are noticed.

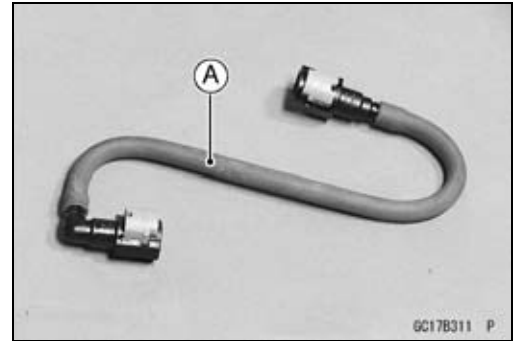

- To maintain the correct fuel/air mixture (F/A), there must be no inlet air leaks in the DFI system. Be sure to install the oil filler plug [A] after filling the engine oil.  
Clutch Cover [B]

**Torque - Oil Filler Plug: 1.5 N·m (0.15 kgf·m, 13 in·lb)**

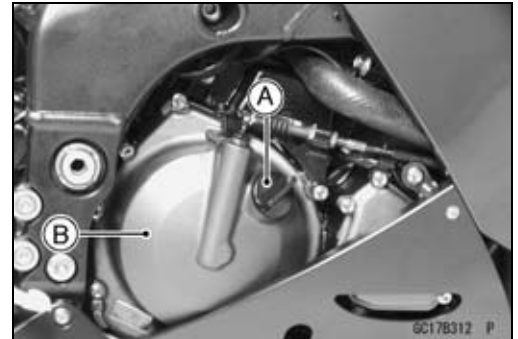

## 3-22 FUEL SYSTEM (DFI)

### Troubleshooting the DFI System

#### Outline

When an abnormality in the system occurs, the FI indicator LED (Light Emitting Diode) light goes on to alert the rider on the meter panel. In addition, the condition of the problem is stored in the memory of the ECU (electronic control unit). With the engine stopped and turned in the self-diagnosis mode, the service code [A] is indicated by the number of times the FI indicator LED light blinks.

When due to a malfunction, the FI indicator LED light remains lit, ask the rider about the conditions [B] under which the problem occurred and try to determine the cause [C]. Don't rely solely on the DFI self-diagnosis function, use common sense; first conduct a pre-diagnosis inspection, check the ECU for ground and power supply, the fuel line for no fuel leaks, and for correct pressure. The pre-diagnosis items are not indicated by the FI indicator LED light.

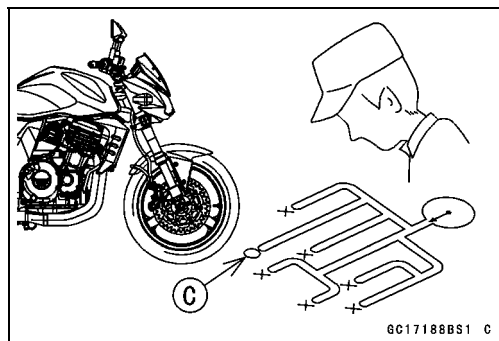
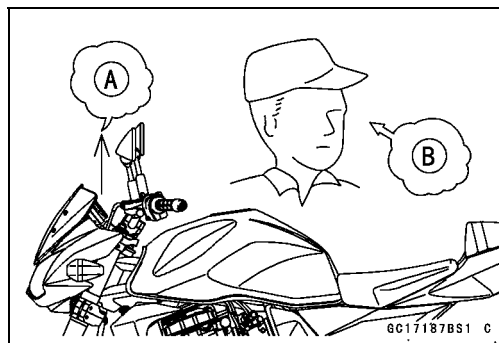

Even when the DFI system is operating normally, the FI indicator LED light [A] may light up under strong electrical interference. No remedy needed. Turn the ignition SW (switch) OFF to stop the indicator light.

When the FI indicator LED light goes on and the motorcycle is brought in for repair, check the service codes.

When the repair has been done, the LED light doesn't go on. But the service codes stored in memory are not erased to preserve the problem history, and the LED light can display the codes in the self-diagnosis mode. The problem history is referred when solving unstable problems.



Much of the DFI system troubleshooting work consists of confirming continuity of the wiring. The DFI parts are assembled and adjusted with precision, and it is impossible to disassemble or repair them.

- When checking the DFI parts, use a digital meter which can be read two decimal place voltage or resistance.

- Remove:

  - Seats (see Frame chapter)

- The DFI part connectors have seals, including the ECU.

  - When measuring the input or output voltage with the connector joined, use the needle adapter set. Insert the needle adapter inside the seal until the needle adapter reaches the terminal.

**Special Tool - Needle Adapter Set: 57001-1457**

#### CAUTION

**Tape the leads to prevent short circuit of the leads.**



## Troubleshooting the DFI System

○After measurement, remove the needle adapters and apply silicone sealant to the seals [A] of the connector [B] for waterproofing.

**Silicone Sealant (Kawasaki Bond: 56019-120)**  
**Seals of Connector**

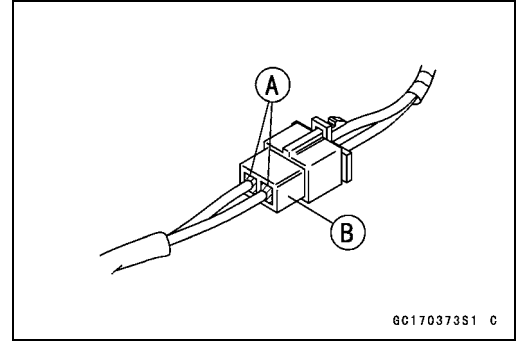

6C170373S1 C

- Always check battery condition before replacing the DFI parts. A fully charged battery is a must for conducting accurate tests of the DFI system.
- Trouble may involve one or in some cases all items. Never replace a defective part without determining what CAUSED the problem. If the problem was caused by some other item or items, they too must be repaired or replaced, or the new replacement part will soon fail again
- Measure coil winding resistance when the DFI part is cold (at room temperature)
- Do not adjust or remove the throttle sensor.
- Do not directly connect a 12 V battery to a fuel injector. Insert a resistor (5 ~ 7 Ω ) or a bulb (12 V × 3 ~ 3.4 W) in series between the battery and the injector.
- The DFI parts have been adjusted and set with precision. Therefore, they should be handled carefully, never strike sharply, as with a hammer, or allowed to drop on a hard surface. Such a shock to the parts can damage them.
- Check wiring and connections from the ECU connector to the suspected faulty DFI parts, using the hand tester (special tool, analog tester) rather than a digital tester.

**Special Tool - Hand Tester: 57001-1394**

- Make sure all connectors in the circuit are clean and tight, and examine wires for signs of burning, fraying, etc. Deteriorated leads and bad connections can cause reappearance of problems and unstable operation of the DFI system.
- ★ If any wiring is deteriorated, replace the wiring.

## 3-24 FUEL SYSTEM (DFI)

### Troubleshooting the DFI System

- Pull each connector [A] apart and inspect it for corrosion, dirt, and damage.
- ★ If the connector is corroded or dirty, clean it carefully. If it is damaged, replace it. Connect the connectors securely.
- Check the wiring for continuity.
- Use the wiring diagram to find the ends of the lead which is suspected of being a problem.
- Connect the hand tester between the ends of the leads.
- Set the tester to the  $\times 1 \Omega$  range, and read the tester.
- ★ If the tester does not read  $0 \Omega$ , the lead is defective. Replace the lead or the main harness or the sub harness.

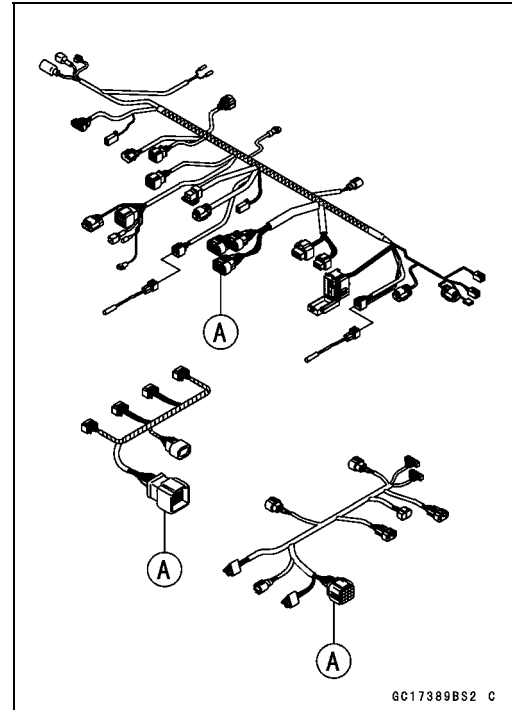

- If both ends of a harness [A] are far apart, ground [B] the one end [C], using a jumper lead [D] and check the continuity between the end [E] and the ground [F]. This enables to check a long harness for continuity. If the harness is open, repair or replace the harness.

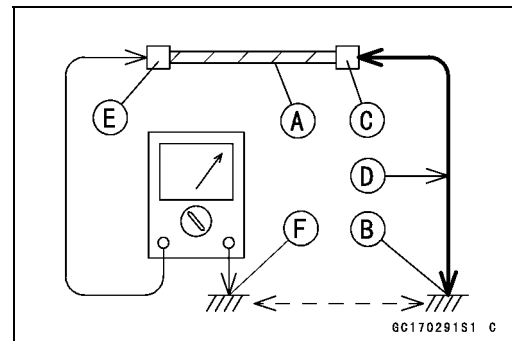

- When checking a harness [A] for short circuit, open one end [B] and check the continuity between the other end [C] and ground [D]. If there is continuity, the harness has a short circuit to ground, and it must be repaired or replaced.

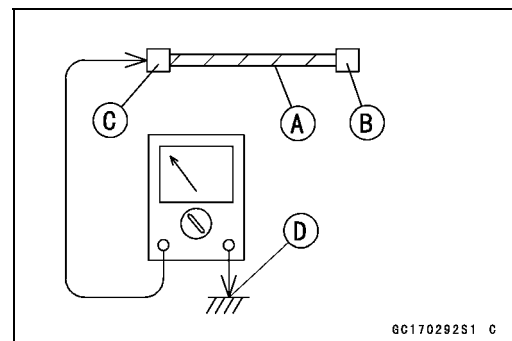

## Troubleshooting the DFI System

- Narrow down suspicious locations by repeating the continuity tests from the ECU connectors.
- ★ If no abnormality is found in the wiring or connectors, the DFI parts are the next likely suspects. Check the part, starting with input and output voltages. However, there is no way to check the ECU itself.
- ★ If an abnormality is found, replace the affected DFI part.
- ★ If no abnormality is found in the wiring, connectors, and DFI parts, replace the ECU.
- The diagnosis flow chart illustrates the above procedures.
- After inspection, be sure to connect all the DFI electrical connectors. Do not turn the ignition SW ON while the DFI electrical connectors and ignition system connectors are disconnected. Otherwise, the ECU memorizes service codes as open circuit.

### ○ Lead Color Codes:

BK: Black	G: Green	P: Pink
BL: Blue	GY: Gray	PU: Purple
BR: Brown	LB: Light blue	R: Red
CH: Chocolate	LG: Light green	W: White
DG: Dark green	O: Orange	Y: Yellow

### ○ Electrical Connectors:

Female Connectors [A]

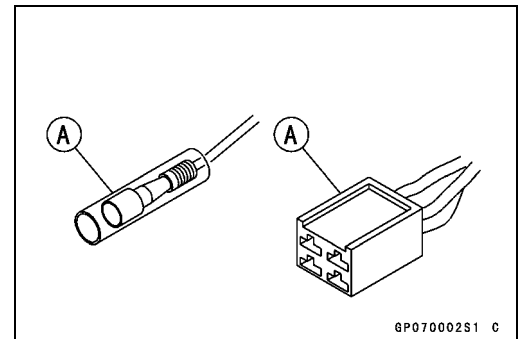

Male Connectors [B]

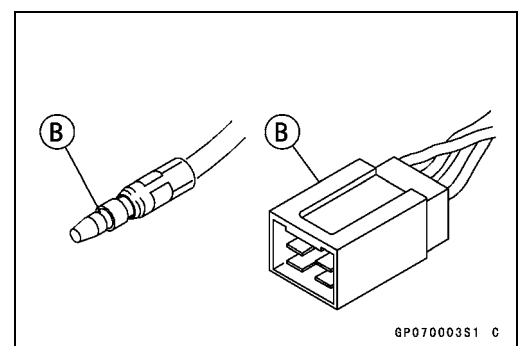

## 3-26 FUEL SYSTEM (DFI)

### Troubleshooting the DFI System

#### DFI Diagnosis Flow Chart

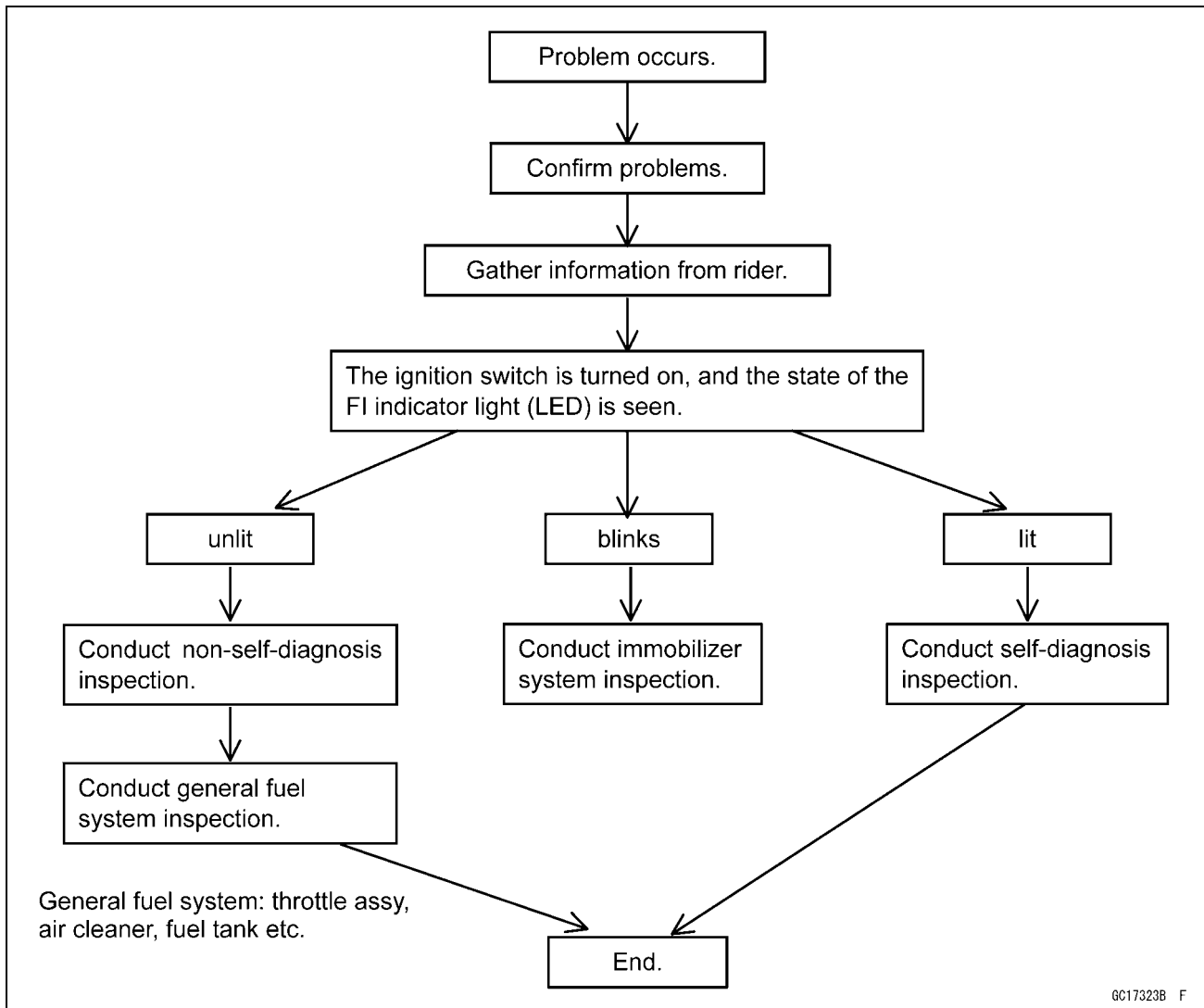

#### Inquiries to Rider

- Each rider reacts to problems in different ways, so it is important to confirm what kind of symptoms the rider has encountered.
- Try to find out exactly what problem occurred under exactly what conditions by asking the rider; knowing this information may help you reproduce the problem.
- The diagnosis sheet will help prevent you from overlooking any areas, and will help you decide if it is a DFI system problem, or a general engine problem.

Troubleshooting the DFI System

Sample Diagnosis Sheet

<b>Rider name:</b>	<b>Registration No. (license plate No.):</b>	<b>Year of initial registration:</b>
<b>Model:</b>	<b>Engine No.:</b>	<b>Frame No.:</b>
<b>Date problem occurred:</b>		<b>Mileage:</b>
<b>Environment when problem occurred.</b>		
Weather	<input type="checkbox"/> fine, <input type="checkbox"/> cloudy, <input type="checkbox"/> rain, <input type="checkbox"/> snow, <input type="checkbox"/> always, <input type="checkbox"/> other:	
Temperature	<input type="checkbox"/> hot, <input type="checkbox"/> warm, <input type="checkbox"/> cold, <input type="checkbox"/> very cold, <input type="checkbox"/> always	
Problem frequency	<input type="checkbox"/> chronic, <input type="checkbox"/> often, <input type="checkbox"/> once	
Road	<input type="checkbox"/> street, <input type="checkbox"/> highway, <input type="checkbox"/> mountain road ( <input type="checkbox"/> uphill, <input type="checkbox"/> downhill), <input type="checkbox"/> bumpy, <input type="checkbox"/> pebble	
Altitude	<input type="checkbox"/> normal, <input type="checkbox"/> high (about 1000 m or more)	
<b>Motorcycle conditions when problem occurred.</b>		
FI indicator LED light	<input type="checkbox"/> lights up immediately after ignition SW ON, and goes off after 1 ~ 2 seconds (normal).	
	<input type="checkbox"/> lights up immediately after ignition SW ON, and stays on (DFI problem)	
	<input type="checkbox"/> lights up immediately after ignition SW ON, and blinks (immobilizer system problem)	
	<input type="checkbox"/> lights up immediately after ignition SW ON, but goes off after about 10 seconds (DFI problem).	
	<input type="checkbox"/> unlights (LED light, ECU or its wiring fault).	
	<input type="checkbox"/> sometimes lights up (probably wiring fault).	
Starting difficulty	<input type="checkbox"/> starter motor not rotating.	
	<input type="checkbox"/> starter motor rotating but engine doesn't turn over.	
	<input type="checkbox"/> starter motor and engine don't turn over.	
	<input type="checkbox"/> no fuel flow ( <input type="checkbox"/> no fuel in tank, <input type="checkbox"/> no fuel pump sound).	
	<input type="checkbox"/> engine flooded (do not crank engine with throttle opened, which promotes engine flooding).	
	<input type="checkbox"/> no spark.	
	<input type="checkbox"/> choke lever is not pulled fully when using the lever (pull it fully when using).	
<input type="checkbox"/> other:		
Engine stalls	<input type="checkbox"/> right after starting.	
	<input type="checkbox"/> when opening throttle grip.	
	<input type="checkbox"/> when closing throttle grip.	
	<input type="checkbox"/> when moving off.	
	<input type="checkbox"/> when stopping the motorcycle.	
	<input type="checkbox"/> when cruising.	
<input type="checkbox"/> other:		

### 3-28 FUEL SYSTEM (DFI)

#### Troubleshooting the DFI System

Poor running at low speed	<input type="checkbox"/> very low idle speed, <input type="checkbox"/> very high idle speed, <input type="checkbox"/> rough idle speed.
	<input type="checkbox"/> battery voltage is low (charge the battery).
	<input type="checkbox"/> spark plug loose (tighten it).
	<input type="checkbox"/> spark plug dirty, broken, or gap maladjusted (remedy it).
	<input type="checkbox"/> backfiring.
	<input type="checkbox"/> afterfiring.
	<input type="checkbox"/> hesitation when acceleration.
	<input type="checkbox"/> engine oil viscosity too high.
	<input type="checkbox"/> brake dragging.
	<input type="checkbox"/> engine overheating.
	<input type="checkbox"/> clutch slipping.
<input type="checkbox"/> other:	
Poor running or no power at high speed	<input type="checkbox"/> spark plug loose (tighten it).
	<input type="checkbox"/> spark plug dirty, broken, or gap maladjusted (remedy it).
	<input type="checkbox"/> spark plug incorrect (replace it).
	<input type="checkbox"/> knocking (fuel poor quality or incorrect, → use high-octane gasoline).
	<input type="checkbox"/> brake dragging.
	<input type="checkbox"/> clutch slipping.
	<input type="checkbox"/> engine overheating.
	<input type="checkbox"/> engine oil level too high.
	<input type="checkbox"/> engine oil viscosity too high.
<input type="checkbox"/> other:	

**DFI System Troubleshooting Guide**

**NOTE**

- *This is not an exhaustive list, giving every possible cause for each problem listed. It is meant simply as a rough guide to assist the troubleshooting for some of the more common difficulties.*
- *The ECU may be involved in the DFI electrical and ignition system troubles. If these parts and circuits are checked out good, be sure to check the ECU for ground and power supply. If the ground and power supply are checked good, replace the ECU.*

**Engine Doesn't Start, Starting Difficulty**

Symptoms or possible Causes	Actions (chapter)
<b>Starter motor not rotating:</b>	
Ignition and engine stop switches not ON	Turn both switches ON.
Starter lockout switch or neutral switch trouble	Inspect (see chapter 16)
Starter motor trouble	Inspect (see chapter 16).
Battery voltage low	Inspect and charge (see chapter 16).
Starter relays not contacting or operating	Inspect the starter relay (see chapter 16).
Starter button not contacting	Inspect and replace (see chapter 16).
Starter system wiring open or shorted	Inspect the wiring (see chapter 16).
Ignition switch trouble	Inspect and replace (see chapter 16).
Engine stop switch trouble	Inspect and repair or replace (see chapter 16).
Main 30 A or ignition fuse blown	Inspect and replace (see chapter 16).
<b>Starter motor rotating but engine doesn't turn over:</b>	
Starter clutch trouble	Inspect (see chapter 16).
Starter idle gear trouble	Inspect (see chapter 16).
<b>Engine won't turn over:</b>	
Valve seizure	Inspect and replace (see chapter 5).
Cylinder, piston seizure	Inspect and replace (see chapter 5).
Camshaft seizure	Inspect and replace (see chapter 5).
Connecting rod small end seizure	Inspect and replace (see chapter 9).
Connecting rod big end seizure	Inspect and replace (see chapter 9).
Crankshaft seizure	Inspect and replace (see chapter 9).
Transmission gear or bearing seizure	Inspect and replace (see chapter 9).
Balancer bearing seizure	Inspect and replace (see chapter 9).
<b>No fuel flow:</b>	
No or little fuel in tank	Supply fuel (see Owner's Manual).
Fuel pump not rotating	Inspect (see chapter 3).
Fuel injector trouble	Inspect and replace (see chapter 3).
Fuel tank air vent obstructed	Inspect and repair (see chapter 3).
Fuel filter or pump screen clogged	Inspect and replace fuel pump (see chapter 3).
Fuel pressure regulator clogged	Inspect and replace fuel pump (see chapter 3).
Fuel line clogged	Inspect and repair (see chapter 3).
<b>Engine flooded:</b>	
Spark plug dirty, broken or gap maladjusted	Replace (see chapter 2).
Starting technique faulty	When flooded, don't crank engine with throttle fully opened.
<b>No spark or spark weak:</b>	
Ignition and engine stop switches not ON	Turn both switches ON .

### 3-30 FUEL SYSTEM (DFI)

#### DFI System Troubleshooting Guide

Symptoms or possible Causes	Actions (chapter)
Clutch lever not pulled in and gear not in neutral whether sidestand up or not	Pull the lever in and shift the gear in neutral.
Though clutch lever pulled in, sidestand up and gear not in neutral	Sidestand down and clutch lever pulled in whether gear in neutral or not
Vehicle-down-sensor coming off	Reinstall (see chapter 3).
Vehicle-down-sensor trouble	Inspect (see chapter 3) .
ECU ground or power supply trouble	Inspect (see chapter 3) .
Battery voltage low	Inspect and charge (see chapter 16).
Spark plug dirty, broken or gap maladjusted	Replace (see chapter 2).
Spark plug cap trouble	Inspect stick coil (see chapter 16).
Spark plug cap shorted or not in good contact	Reinstall or inspect stick coil (see chapter 16).
Spark plug incorrect	Replace it with the correct plug (see chapter 16).
IC igniter in ECU trouble	Inspect (see chapter 16).
Neutral, starter lockout or sidestand switch trouble	Inspect each switch (see chapter 16).
Crankshaft sensor trouble	Inspect (see chapter 16).
Stick coil trouble	Inspect (see chapter 16).
Ignition switch shorted	Inspect and replace (see chapter 16).
Engine stop switch shorted	Inspect and repair or replace (see chapter 2) .
Starter system wiring shorted or open	Inspect and repair or replace (see chapter 16).
Main 30 A or ignition fuse blown	Inspect and replace (see chapter 16).
<b>Fuel/air mixture incorrect:</b>	
Air cleaner clogged, poorly sealed or missing	Clean or reinstall (see chapter 3).
Leak from oil filler cap, crankcase breather hose or air cleaner drain hose	Inspect and repair or replace (see chapter 3).
Water or foreign matter in fuel	Change fuel. Inspect and clean fuel system (see chapter 3).
Fuel pressure regulator trouble	Inspect fuel pressure and replace fuel pump (see chapter 3).
Main throttle sensor trouble	Inspect (see chapter 3).
Fuel pressure may be low	Inspect (see chapter 3).
Fuel pump trouble	Inspect (see chapter 3).
Fuel injector trouble	Inspect (see chapter 3).
Inlet air pressure sensor trouble	Inspect (see chapter 3).
Atmospheric pressure sensor trouble	Inspect (see chapter 3).
Inlet air temperature sensor trouble	Inspect (see chapter 3).
Water temperature sensor trouble	Inspect (see chapter 3).
Crankshaft sensor trouble	Inspect (see chapter 3).
<b>Compression low:</b>	
Spark plug loose	Reinstall (see chapter 16).
Cylinder head not sufficiently tightened down	Tighten (see chapter 5).
Cylinder, piston worn	Inspect and replace (see chapter 5).
Piston ring bad (worn, weak, broken or sticking)	Inspect and replace (see chapter 5).
Piston ring/groove clearance excessive	Inspect and replace (see chapter 5).
Cylinder head gasket damaged	Replace (see chapter 5).



**DFI System Troubleshooting Guide**

<b>Symptoms or possible Causes</b>	<b>Actions (chapter)</b>
Cylinder head warped	Inspect and replace (see chapter 5).
No valve clearance	Adjust (see chapter 2).
Valve guide worn	Inspect and replace (see chapter 5).
Valve spring broken or weak	Inspect and replace (see chapter 5).
Valve not seating properly (valve bent, worn or carbon accumulating on seating surface)	Inspect and repair or replace (see chapter 5).

**Poor Running at Low Speed**

<b>Symptoms or Possible Causes</b>	<b>Actions (chapter)</b>
<b>Spark weak:</b>	
Battery voltage low	Inspect and charge (see chapter 16).
Spark plug dirty, broken or gap maladjusted	Replace (see chapter 2).
Spark plug cap trouble	Inspect the stick coil (see chapter 16).
Spark plug cap shorted or not in good contact	Reinstall or inspect stick coil (see chapter 16).
Spark plug incorrect	Replace it with the correct plug (see chapter 16).
IC igniter in ECU trouble	Inspect (see chapter 16).
Crankshaft sensor trouble	Inspect (see chapter 16).
Stick coil trouble	Inspect (see chapter 16).
<b>Fuel/air mixture incorrect:</b>	
Little fuel in tank	Supply fuel (see Owner's Manual).
Air cleaner clogged, poorly sealed, or missing	Clean element or inspect sealing (see chapter 2, 3).
Air cleaner duct loose	Reinstall (see chapter 3).
Air cleaner O-ring damaged	Replace (see chapter 3).
Fuel tank air vent obstructed	Inspect and repair (see chapter 3).
Throttle body assy loose	Reinstall (see chapter 3).
Throttle body assy O-ring damage	Replace (see chapter 3).
Fuel filter or pump screen clogged	Inspect and replace fuel pump (see chapter 3).
Fuel pressure regulator clogged	Inspect fuel pressure and replace fuel pump (see chapter 3).
Fuel line clogged	Inspect and repair (see chapter 3).
Inlet air pressure sensor trouble	Inspect (see chapter 3).
Inlet air temperature sensor trouble	Inspect (see chapter 3).
Thermostat trouble	Inspect and replace (see chapter 4).
<b>Unstable (rough) idling:</b>	
Fuel injector trouble	Inspect (see chapter 3).
Main throttle sensor trouble	Inspect (see chapter 3).
Crankshaft sensor trouble	Inspect (see chapter 3).
Throttle valves not synchronizing	Inspect (see chapter 2).
Inlet air temperature sensor trouble	Inspect (see chapter 3).
Water temperature sensor trouble	Inspect (see chapter 3).
Atmospheric pressure sensor trouble	Inspect (see chapter 3).
Fuel pressure too low or too high	Inspect (see chapter 3).
Battery voltage low	Inspect and charge (see chapter 16).

### 3-32 FUEL SYSTEM (DFI)

#### DFI System Troubleshooting Guide

Symptoms or Possible Causes	Actions (chapter)
<b>Incorrect idle speed:</b>	
Water temperature sensor trouble	Inspect (see chapter 3).
Main throttle sensor trouble	Inspect (see chapter 3).
<b>Engine stalls easily:</b>	
Fuel pump trouble	Inspect (see chapter 3).
Fuel injector trouble	Inspect (see chapter 3).
Main throttle sensor trouble	Inspect (see chapter 3).
Camshaft position sensor trouble	Inspect (see chapter 3).
Fuel pressure too low or too high	Inspect (see chapter 3).
Inlet air pressure sensor trouble	Inspect (see chapter 3).
Water temperature sensor trouble	Inspect (see chapter 3).
Inlet air temperature sensor trouble	Inspect (see chapter 3).
Fuel line clogged	Inspect and repair (see chapter 3).
Fuel pressure too low or too high	Inspect (see chapter 3).
Fuel pressure regulator trouble	Inspect fuel pressure and replace fuel pump (see chapter 3).
Crankshaft sensor trouble	Inspect (see chapter 16).
Stick coil trouble	Inspect (see chapter 16).
<b>Compression Low:</b>	
Spark plug loose	Reinstall (see chapter 16).
Cylinder head not sufficiently tightened down	Tighten (see chapter 5).
No valve clearance	Adjust (see chapter 2).
Cylinder, piston worn	Inspect and replace (see chapter 5).
Piston ring bad (worn, weak, broken or sticking )	Inspect and replace (see chapter 5).
Piston ring/groove clearance excessive	Inspect and replace (see chapter 5).
Cylinder head gasket damaged	Replace (see chapter 5).
Cylinder head warped	Inspect and replace (see chapter 5).
Valve guide worn or stem seal damaged	Inspect and replace (see chapter 5).
Valve spring broken or weak	Inspect and replace (see chapter 5).
Valve not seating properly (valve bent, worn or carbon accumulating on seating surface)	Inspect and repair or replace (see chapter 5).
Camshaft cam worn	Inspect and replace (see chapter 5).
<b>Hesitation:</b>	
Too low fuel pressure	Inspect (see chapter 3).
Clogged fuel line	Inspect and repair (see chapter 3).
Cracked or obstructed inlet air pressure sensor hose	Inspect and repair or replace (see chapter 3).
Fuel pump trouble	Inspect (see chapter 3).
Fuel injector trouble	Inspect (see chapter 3).
Inlet air temperature sensor trouble	Inspect (see chapter 3).
Main throttle sensor trouble	Inspect (see chapter 3).
Subthrottle sensor trouble	Inspect (see chapter 3).
Subthrottle valve actuator trouble	Inspect (see chapter 3).
Water temperature sensor trouble	Inspect (see chapter 3).
Atmospheric pressure sensor trouble	Inspect (see chapter 3).

**DFI System Troubleshooting Guide**

Symptoms or Possible Causes	Actions (chapter)
Inlet air pressure sensor trouble	Inspect (see chapter 3).
Loose injector connectors	Remedy (see chapter 3).
Crankshaft sensor trouble	Inspect and repair or replace (see chapter 16).
Stick coil trouble	Inspect and repair or replace (see chapter 16).
Loose terminal of battery (-) lead or engine ground lead	Inspect and repair (see chapter 16).
Delay of ignition timing	Inspect crankshaft sensor and IC igniter in ECU (see chapter 16).
<b>Poor acceleration:</b>	
Too low fuel pressure	Inspect (see chapter 3).
Water or foreign matter in fuel	Change fuel. Inspect and clean fuel system (see chapter 3).
Clogged fuel filter or pump screen	Inspect and replace fuel pump (see chapter 3).
Fuel pump trouble	Inspect (see chapter 3).
Fuel injector trouble	Inspect (see chapter 3).
Inlet air temperature sensor trouble	Inspect (see chapter 3).
Water temperature sensor trouble	Inspect (see chapter 3).
Atmospheric pressure sensor trouble	Inspect (see chapter 3).
Subthrottle sensor trouble	Inspect (see chapter 3).
Subthrottle valve actuator trouble	Inspect (see chapter 3).
Stick coil trouble	Inspect and replace (see chapter 16).
Engine oil level to high	Repair (see chapter 7).
Spark plug dirty, broken or gap maladjusted	Replace (see chapter 2).
<b>Stumble:</b>	
Too low fuel pressure	Inspect (see chapter 3).
Fuel injector trouble	Inspect (see chapter 3).
Main throttle sensor malfunction	Inspect (see chapter 3).
Subthrottle sensor trouble	Inspect (see chapter 3).
Subthrottle valve actuator trouble	Inspect (see chapter 3).
Water temperature sensor trouble	Inspect (see chapter 3).
Inlet air pressure sensor trouble	Inspect (see chapter 3).
<b>Surge:</b>	
Unstable fuel pressure	Fuel pressure regulator trouble (Inspect and replace fuel pump) or kinked fuel line (Inspect and repair fuel line) (see chapter 3).
Fuel injector trouble	Inspect (see chapter 3).
Water temperature sensor trouble	Inspect (see chapter 3).
<b>Backfiring when deceleration:</b>	
Spark plug dirty, broken or gap maladjusted	Replace (see chapter 2).
Too low fuel pressure	Inspect (see chapter 3).
Fuel pump trouble	Inspect (see chapter 3).
Main throttle sensor trouble	Inspect (see chapter 3).
Inlet air temperature sensor trouble	Inspect (see chapter 3).
Water temperature sensor trouble	Inspect (see chapter 3).
Atmospheric pressure sensor trouble	Inspect (see chapter 3).

### 3-34 FUEL SYSTEM (DFI)

#### DFI System Troubleshooting Guide

Symptoms or Possible Causes	Actions (chapter)
Inlet air pressure sensor trouble	Inspect (see chapter 3).
Vacuum switch valve broken	Inspect and replace (see chapter 5).
Air suction valve trouble	Inspect and replace (see chapter 5).
<b>After fire:</b>	
Crankshaft sensor trouble	Inspect (see chapter 16).
Spark plug burned or gap maladjusted	Replace (see chapter 2).
Inlet air temperature sensor trouble	Inspect (see chapter 3).
Water temperature sensor trouble	Inspect (see chapter 3).
Atmospheric pressure sensor trouble	Inspect (see chapter 3).
Inlet air pressure sensor trouble	Inspect (see chapter 3).
Fuel injector trouble	Inspect (see chapter 3).
<b>Run-on (dieseling):</b>	
Ignition switch trouble	Inspect and replace (see chapter 16).
Engine stop switch trouble	Inspect and repair or replace (see chapter 2).
Fuel injector trouble	Inspect (see chapter 3).
Loose terminal of battery (-) lead or ECU ground lead	Inspect and repair (see chapter 16).
Carbon accumulating on valve seating surface	Repair (see chapter 5).
Engine overheating	(see Overheating of Troubleshooting Guide, see chapter 17)
<b>Other:</b>	
Engine oil viscosity too high	Change (see chapter 2).
Drive train trouble	Inspect drive chain (see chapter 2) and sprocket (see chapter 11).
Brake dragging	Inspect caliper fluid seal damage or clogging of master cylinder relief and supply ports (see chapter 12).
Clutch slipping	Inspect friction plates for wear (see chapter 6).
Engine overheating	(see Overheating of Troubleshooting Guide, see chapter 17)
Vacuum switch valve trouble	Inspect and replace (see chapter 5).
Air suction valve trouble	Inspect and replace (see chapter 5).
Intermittent any DFI fault and its recovery	Check that DFI connectors are clean and tight, and examine wires for signs of burning or fraying (see chapter 3).

#### Poor Running or No Power at High Speed:

Symptoms or Possible Causes	Actions (chapter)
<b>Firing incorrect:</b>	
Spark plug dirty, broken or maladjusted	Replace (see chapter 2).
Spark plug cap trouble	Inspect stick coil (see chapter 16).
Spark plug cap shorted or not in good contact	Reinstall or inspect stick coil (see chapter 16).
Spark plug incorrect	Replace it with the correct plug (see chapter 16).
IC igniter in ECU trouble	Inspect (see chapter 16).
Crankshaft sensor trouble	Inspect (see chapter 16).

**DFI System Troubleshooting Guide**

Symptoms or Possible Causes	Actions (chapter)
Stick coil trouble	Inspect (see chapter 16).
<b>Fuel/air mixture incorrect:</b>	
Air cleaner clogged, poorly sealed, or missing	Clean element or inspect sealing (see chapter 3).
Air cleaner duct loose	Reinstall (see chapter 3).
Air cleaner O-ring damaged	Replace (see chapter 3).
Water or foreign matter in fuel	Change fuel. Inspect and clean fuel system (see chapter 3).
Throttle body assy loose	Reinstall (see chapter 3).
Throttle body assy O-ring damaged	Replace (see chapter 3).
Fuel tank air vent obstructed	Inspect and repair (see chapter 3).
Fuel line clogged	Inspect and repair (see chapter 3).
Fuel pump operates intermittently and often DFI fuse blows.	Pump bearings may wear. Replace the pump (see chapter 3).
Fuel pump trouble	Inspect (see chapter 3).
Inlet air temperature sensor trouble	Inspect (see chapter 3).
Main throttle sensor trouble	Inspect (see chapter 3).
Atmospheric pressure sensor trouble	Inspect (see chapter 3).
Inlet air pressure sensor trouble	Inspect (see chapter 3).
Cracked or obstructed inlet air pressure sensor hose	Inspect and repair or replace (see chapter 3).
Injector clogged	Visually inspect and replace (see chapter 3).
<b>Compression low:</b>	
Spark plug loose	Reinstall (see chapter 16).
Cylinder head not sufficiently tightened down	Tighten (see chapter 5).
No valve clearance	Adjust (see chapter 2).
Cylinder, piston worn	Inspect and replace (see chapter 5).
Piston ring bad (worn, weak, broken or sticking)	Inspect and replace (see chapter 5).
Piston ring /groove clearance excessive	Inspect and replace (see chapter 5).
Cylinder head gasket damaged	Replace (see chapter 5) .
Cylinder head warped	Inspect and replace (see chapter 5).
Valve spring broken or weak	Inspect and replace (see chapter 5).
Valve not seating properly (valve bent , worn or carbon accumulating on the seating surface)	Inspect and repair or replace (see chapter 5).
<b>Knocking:</b>	
Carbon built up in combustion chamber	Repair (see chapter 5).
Fuel poor quality or incorrect (Use the gasoline recommended in the Owner's Manual)	Change fuel (see chapter 3).
Spark plug incorrect	Replace it with the correct plug (see chapter 16).
Stick coil trouble	Inspect (see chapter 16).
IC igniter in ECU trouble	Inspect (see chapter 16).
Inlet air temperature sensor trouble	Inspect (see chapter 3).
Atmospheric pressure sensor trouble	Inspect (see chapter 3).
<b>Miscellaneous:</b>	
Subthrottle sensor trouble	Inspect (see chapter 3).
Subthrottle valve actuator trouble	Inspect (see chapter 3).

### 3-36 FUEL SYSTEM (DFI)

#### DFI System Troubleshooting Guide

Symptoms or Possible Causes	Actions (chapter)
Speed sensor trouble	Inspect (see chapter 3).
Throttle valves won't fully open	Inspect throttle cable and lever linkage (see chapter 3).
Brake dragging	Inspect caliper fluid seal damage or clogging of master cylinder relief and supply ports (see chapter 12).
Clutch slipping	Inspect friction plates for wear (see chapter 6).
Engine overheating-Water temperature sensor, crankshaft sensor or speed sensor trouble	(see Overheating of Troubleshooting Guide in chapter 17).
Engine oil level too high	Repair (see chapter 7).
Engine oil viscosity too high	Change (see chapter 2).
Drive train trouble	Inspect drive chain (see chapter 2) and sprockets (see chapter 11).
Camshaft cam worn	Inspect and replace (see chapter 5).
Vacuum switch valve trouble	Inspect and replace (see chapter 5).
Air suction valve trouble	Inspect and replace (see chapter 5).
Catalytic converters melt down due to muffler overheating (KLEEN)	Replace muffler (see chapter 5).
<b>Exhaust Smokes Excessively:</b>	
<b>(White smokes)</b>	
Piston oil ring worn	Inspect and replace (see chapter 5).
Cylinder worn	Inspect and replace (see chapter 5).
Valve oil seal damaged	Replace (see chapter 5).
Valve guide worn	Replace the guide (see chapter 5).
Engine oil level too high	Repair (see chapter 7).
<b>(Black smoke)</b>	
Air cleaner clogged	Clean (see chapter 3).
Too high fuel pressure	Inspect (see chapter 3) .
Injector stuck open	Inspect (see chapter 3).
Water temperature sensor trouble	Inspect and replace (see chapter 3).
Inlet air temperature sensor trouble	Inspect and replace (see chapter 3).
<b>(Brown smoke)</b>	
Air cleaner duct loose	Reinstall (see chapter 3).
Air cleaner O-ring damaged	Replace (see chapter 3).
Too low fuel pressure	Inspect fuel line and fuel pump (see chapter 3).
Water temperature sensor trouble	Inspect and replace (see chapter 3).
Inlet air temperature sensor trouble	Inspect and replace (see chapter 3)

## Self-Diagnosis

### Self-diagnosis Outline

The self-diagnosis system has two modes and can be switched to another mode by grounding the self-diagnosis terminal [A].

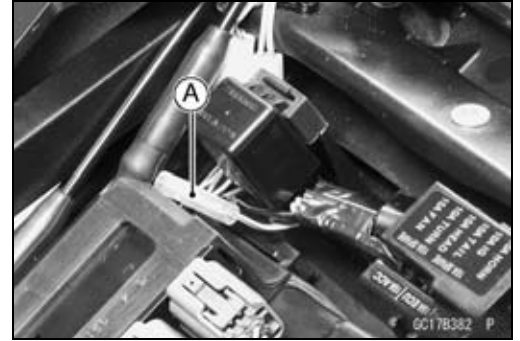

### User Mode

The ECU notifies the rider of troubles in DFI system and ignition system by lighting the FI indicator when DFI system and ignition system parts are faulty, and initiates fail-safe function. In case of serious troubles ECU stops the injection/ignition/starter motor operation.

### Dealer Mode

The FI indicator LED light emits service code(s) to show the problem(s) which the DFI system and ignition system has at the moment of diagnosis.

### Self-diagnosis Procedures

○When a problem occurs with the DFI system and ignition system, the DFI indicator LED light [A] goes on.

#### NOTE

- Use a fully charged battery when conducting self-diagnosis. Otherwise, the LED light blinks very slowly or doesn't blink.
  - Keep the self-diagnosis terminal grounded during self-diagnosis, with an auxiliary lead.
- Remove the seats (see Frame chapter) and pull the self-diagnosis terminal [G].
  - Turn on the ignition switch.
  - Connect an auxiliary lead [E] for grounding to the self-diagnosis terminal.
  - To enter the self-diagnosis dealer mode, ground [A] the self-diagnosis terminal for more than 2 seconds [C], and then keep it grounded continuously [D].
- Count the blinks of the LED light to read the service code. Keep the auxiliary lead ground until you finish reading the service code.

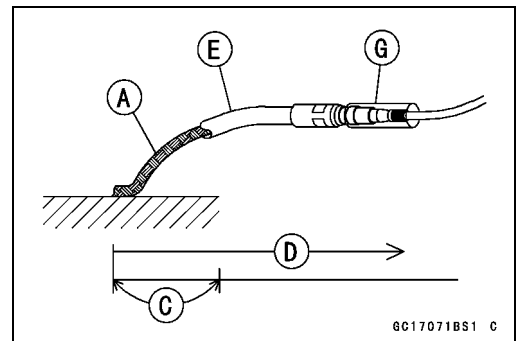

## 3-38 FUEL SYSTEM (DFI)

### Self-Diagnosis

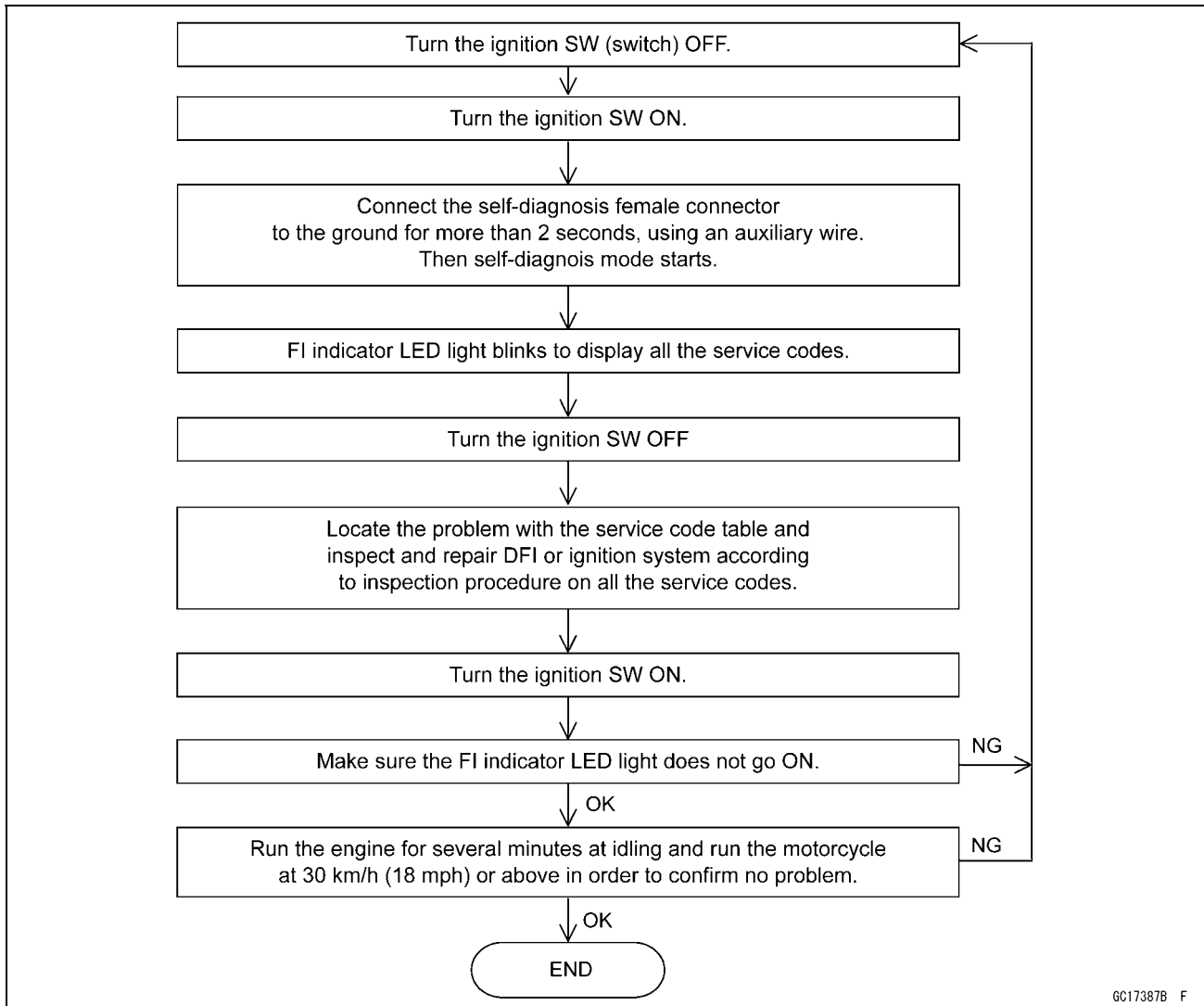

#### Service Code Reading

- Service codes are shown by a series of long and short blinks of the FI indicator LED light as shown below.
  - Read 10th digit and unit digit as the FI indicator LED light blinks.
  - When there are a number of problems, all the service codes can be stored and the display will begin starting from the lowest number service code in the numerical order. Then after completing all codes, the display is repeated until the self-diagnosis terminal is opened.
  - For example, if four problems occurred in the order of 31, 15, 41, 12, the service codes are displayed from the lowest number in the order listed.  
(12 → 15 → 31 → 41) → (12 → 15 → 31 → 41) → . . . (repeated)
  - If there is no problem or when the repair has been done, no service code is shown.
- If the problem is with the following parts, the ECU cannot memorize these problems, the FI indicator LED light doesn't go on, and no service codes can be displayed.
- FI Indicator LED Light
  - DFI Main Relay
  - Ignition Coil Secondary Wiring (check the internal resistance, see Electrical System chapter)
  - ECU Power Source Wiring and Ground Wiring (see ECU Inspection in this chapter)
- For example, if two problems of 12 and 15 occur, the service code 12 and 15 are shown as follows.



Self-Diagnosis

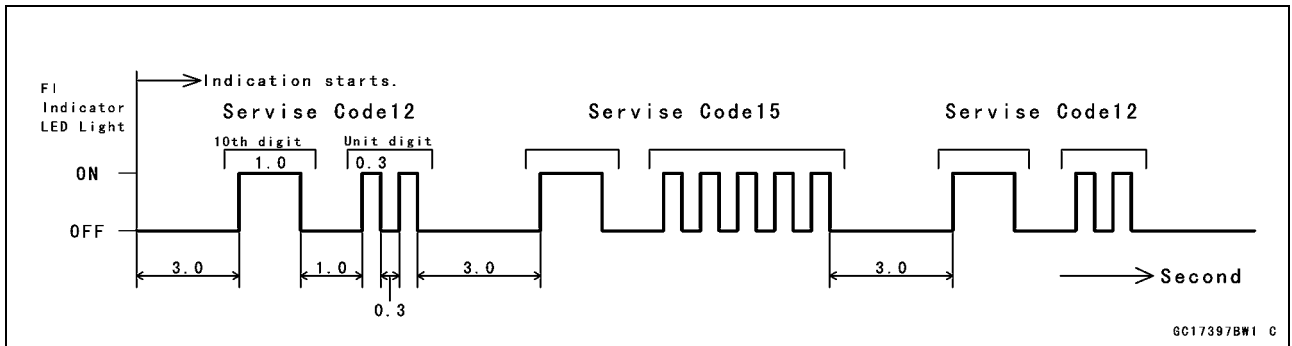

Service Code Erasing

○When the repair has been done, the LED light will not show fault codes any more.













★But even if the repair has been done, the ignition SW is turned OFF, or the battery is disconnected, all the fault codes remain in the ECU, which need not be absolutely erased.

Service Code Table

Service Code	FI Indicator LED Light	Problems
11	ON OFF	Throttle sensor malfunction, wiring open or short
12		Vacuum sensor malfunction, wiring open or short
13		Inlet air temperature sensor malfunction, wiring open or short
14		Water temperature sensor malfunction, wiring open or short
15		Atmospheric pressure sensor malfunction, wiring open or short
21		Crankshaft sensor malfunction, wiring open or short
23		Camshaft position sensor malfunction, wiring open or short
24		Speed sensor malfunction
25		Gear position switch malfunction, wiring open or short
31		Vehicle-down-sensor malfunction, wiring open or short
32		Subthrottle sensor malfunction, wiring open or short
34		Exhaust valve sensor malfunction, wiring open or short
35		Immobilizer amplifier malfunction
36		Blank key detection

## 3-40 FUEL SYSTEM (DFI)

### Self-Diagnosis

Service Code	FI Indicator LED Light	Problems
41		Injector #1 malfunction, wiring open or short
42		Injector #2 malfunction, wiring open or short
43		Injector #3 malfunction, wiring open or short
44		Injector #4 malfunction, wiring open or short
45		Fuel pump relay malfunction, wiring open
46		Fuel pump relay malfunction, relay is stuck
51		Stick (Ignition) coil #1 malfunction, wiring open or short
52		Stick (Ignition) coil #2 malfunction, wiring open or short
53		Stick (Ignition) coil #3 malfunction, wiring open or short
54		Stick (Ignition) coil #4 malfunction, wiring open or short
62		Subthrottle valve actuator malfunction, wiring open or short
63		Exhaust valve actuator malfunction, wiring open or short
75		Main relay malfunction, relay is stuck

#### Notes:

- The ECU may be involved in these problems. If all the parts and circuits checked out good, be sure to check the ECU for ground and power supply. If the ground and power supply are checked good, replace the ECU.
- When no service code is displayed, the electrical parts of the DFI system has no fault, and the mechanical parts of the DFI system and the engine are suspect.

**Self-Diagnosis**

**Backups**

○The ECU takes the following measures to prevent engine damage when the DFI or the ignition system parts have troubles.

Service Codes	Parts	Output Signal Usable Range or Criteria	Backups by ECU
11	Main Throttle Sensor	Main Throttle Sensor Output Voltage 0.66 ~ 4.62 V	If the main throttle sensor system fails (the signal is out of the usable range, wiring short or open), the ECU locks ignition timing into the ignition timing at closed throttle position and sets the DFI in the D-J method.
12	Inlet Air Pressure Sensor	Inlet Air Pressure (absolute) Pv = 100 mmHg ~ 900 mmHg	If the inlet air pressure sensor system fails (the signal Pv is out of the usable range, wiring short or open), the ECU sets the DFI in the α-N method (1).
13	Inlet Air Temperature Sensor	Inlet Air Temperature Ta = - 47°C ~ + 178°C	If the inlet air temperature sensor fails (the signal is out of the usable range, wiring short or open), the ECU sets Ta at 30°C.
14	Water Temperature Sensor	Water Temperature Tw = - 30°C ~ + 120°C	If the water temperature sensor system fails (the signal is out of the usable range, wiring short or open), the ECU sets Tw at 80°C.
15	Atmospheric Pressure Sensor	Absolute Atmospheric Pressure Pa = 100 mmHg ~ 900 mmHg	If the atmospheric pressure sensor system fails (the signal is out of the usable range, wiring short or open), the ECU sets Pa at 760 mmHg (the standard atmospheric pressure).
21	Crankshaft Sensor	Crankshaft sensor cannot send the signal to the ECU during 8 crankings.	If crankshaft sensor fails, the engine stops by itself.
23	Camshaft Position Sensor	Camshaft position sensor cannot send the signal to the ECU during 24 crankings.	If the camshaft position sensor system fails (the signal is missing, wiring short or open), the ECU continues to ignite cylinders in the same sequence following the last good signal.
24	Speed Sensor	Speed sensor must send 4 signals (output signal) to the ECU at the one rotation of the engine sprocket.	If the speed sensor system fails (no signal, wiring short or open), the speedometer shows 0.
25	Gear Position Switch	Gear Position Switch Output Voltage (signal) Vg = 0.2 ~ 4.8 V	If the speed sensor system fails (no signal, wiring short or open), the ECU set the top (6) gear position.
31	Vehicle -down -sensor	Vehicle-down-sensor Output Voltage (signal) Vd = 0.2 V ~ 4.8 V	If the vehicle-down-sensor system has failures (the output voltage Vd is more than usable range, wiring open), the ECU shuts off the fuel pump, the fuel injectors and the ignition system.
32	Subthrottle Sensor	Subthrottle Sensor Output Voltage 0.2 ~ 4.8 V	If the subthrottle sensor system fails (the signal is out of the usable range, wiring short or open), the actuator locks subthrottle valve at full open position.
34	Exhaust Butterfly Valve Actuator	Exhaust Butterfly Valve Output Voltage 0.2 ~ 4.8 V	If the exhaust butterfly valve system fails (the signal is out of the usable range, wiring short or open), the actuator locks exhaust butterfly valve at full open position.
35	Immobilizer Amplifier	-	If the immobilizer system fails (no signal, wiring short or open), the vehicle is no start and run.

### 3-42 FUEL SYSTEM (DFI)

#### Self-Diagnosis

Service Codes	Parts	Output Signal Usable Range or Criteria	Backups by ECU
36	Master or User Key	The user or master key must use register key.	If the blank key or broken key is used, the vehicle is no start and run.
41	Fuel Injector #1	The injector must send signals (output voltage) 16 or more times continuously to the ECU.	If the injector #1 fails (signals less than 16 times, wiring short or open), the ECU shuts off the signal to the injector. Fuel is not supplied to the cylinder #1, though the engine keeps running.
42	Fuel Injector #2	The injector must send signals (output voltage) 16 or more times continuously to the ECU.	If the injector #2 fails (signals less than 16 times, wiring short or open), the ECU shuts off the signal to the injector. Fuel is not supplied to the cylinder #2, though the engine keeps running.
43	Fuel Injector #3	The injector must send signals (output voltage) 16 or more times continuously to the ECU.	If the injector #3 fails (signals less than 16 times, wiring short or open), the ECU shuts off the signal to the injector. Fuel is not supplied to the cylinder #3, though the engine keeps running.
44	Fuel Injector #4	The injector must send signals (output voltage) 16 or more times continuously to the ECU.	If the injector #4 fails (signals less than 16 times, wiring short or open), the ECU shuts off the signal to the injector. Fuel is not supplied to the cylinder #4, though the engine keeps running.
45	Fuel Pump Relay	When the relay OFF condition, battery monitor voltage less than 5 V	–
46	Fuel Pump Relay	When the relay ON condition, battery monitor voltage 5 V or more	If the relay fails, battery monitor voltage 12 V.
51	Stick Coil #1 (Ignition Coil)*	The ignition coil primary winding must send signals (output voltage) 32 or more times continuously to the ECU.	If the ignition primary winding #1 has failures (no signal, wiring short or open), the ECU shuts off the injector #1 to stop fuel to the cylinder #1, though the engine keeps running.
52	Stick Coil #2 (Ignition Coil)*	The ignition coil primary winding must send signals (output voltage) 32 or more times continuously to the ECU.	If the ignition primary winding #2 has failures (no signal, wiring short or open), the ECU shuts off the injector #2 to stop fuel to the cylinder #2, though the engine keeps running.
53	Stick Coil #3 (Ignition Coil)*	The ignition coil primary winding must send signals (output voltage) 32 or more times continuously to the ECU.	If the ignition primary winding #3 has failures (no signal, wiring short or open), the ECU shuts off the injector #3 to stop fuel to the cylinder #3, though the engine keeps running.
54	Stick Coil #4 (Ignition Coil) *	The ignition coil primary winding must send signals (output voltage) 32 or more times continuously to the ECU.	If the ignition primary winding #4 has failures (no signal, wiring short or open), the ECU shuts off the injector #4 to stop fuel to the cylinder #4, though the engine keeps running.

**Self-Diagnosis**

Service Codes	Parts	Output Signal Usable Range or Criteria	Backups by ECU
62	Subthrottle Valve Actuator	The actuator operates open and close of the subthrottle valve by the pulse signal from the ECU.	If the sub throttle actuator fails (the signal is out to the usable range, wiring short or open), the ECU stops the current to the actuator.
63	Exhaust Valve Actuator	The actuator operates open and close of the exhaust valve by the pulse signal from the ECU.	If the sub throttle actuator fails (the signal is out to the usable range, wiring short or open), the ECU stops the current to the actuator.
75	ECU Main Relay	When the relay OFF condition, the main relay is open.	-

**Note:**

(1)  $\alpha$ -N Method: the DFI control method from medium to heavy engine load. When the engine load is light like at idling or low speed, the ECU determines the injection quantity by calculating from the throttle vacuum (vacuum sensor output voltage) and engine speed (crankshaft sensor output voltage). This method is called D-J method. As the engine speed increases, and the engine load turns middle to heavy, the ECU determines the injection quantity by calculating from the throttle opening (throttle sensor output voltage) and the engine speed. This method is called  $\alpha$ -N method.

\* This depends on the number of stopped cylinders.

## 3-44 FUEL SYSTEM (DFI)

### Main Throttle Sensor (Service Code 11)

The main throttle sensor is a rotating variable resistor that change output voltage according to throttle operating. The ECU senses this voltage change and determines fuel injection quantity, and ignition timing according to engine rpm, and throttle opening.

Input Terminal [A]

Output Terminal [B]

Ground Terminal [C]

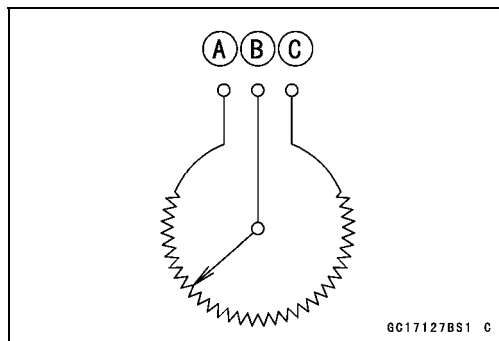

#### Main Throttle Sensor Removal/Adjustment

##### CAUTION

**Do not remove or adjust the main throttle sensor since it has been adjusted and set with precision at the factory.**

**Never drop the sensor, especially on a hard surface. Such a shock to the sensor can damage it.**

Main Throttle Sensor Connector [A]

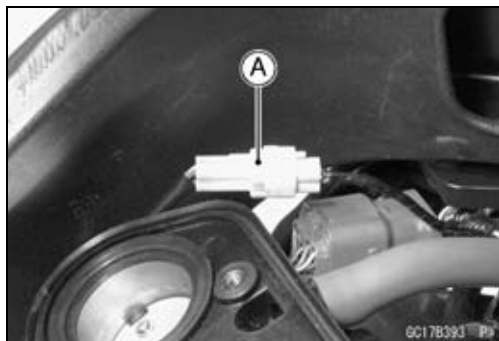

#### Input Voltage Inspection

##### NOTE

○Be sure the battery is fully charged.

- Turn the ignition switch OFF.
- Remove the ECU (see ECU Removal). Do not disconnect the ECU connectors.
- Connect a digital voltmeter [A] to the connectors [B], using the needle adapter set.

**Special Tool - Needle Adapter Set: 57001-1457**

##### Main Throttle Sensor Input Voltage

###### Connections to ECU Connector

Meter (+) → BL lead (terminal 23)

Meter (-) → BR/BK lead (terminal 59)

- Measure the input voltage with the engine stopped, and with the connectors joined.
- Turn the ignition switch ON.

##### Input Voltage at ECU Connector

**Standard: 4.75 ~ 5.25 V DC**

- Turn the ignition switch OFF.
- ★ If the reading of input voltage is less than the standard, check the ECU for its ground, power supply and wiring shorted.
- ★ If the input voltage is within the standard range, check the input voltage at the main throttle sensor connector.
- Remove the throttle body assembly temporarily (see Throttle Body Assy Removal).

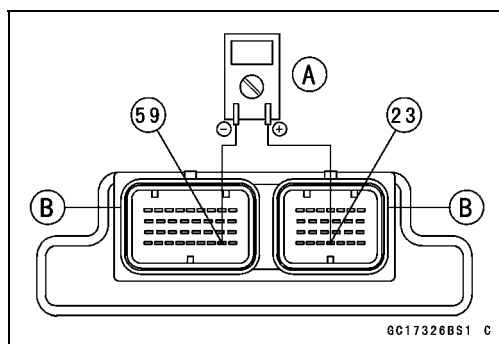

## Main Throttle Sensor (Service Code 11)

- Disconnect the main throttle sensor connector and connect the harness adapter [A] between the harness connector and main throttle sensor connector.
- Connect a digital meter to the harness adapter leads.

**Special Tool - Throttle Sensor Setting Adapter #1: 57001-1400**

### Main Throttle Sensor Input Voltage Connections to Sensor

**Meter (+)** → BL lead

**Meter (-)** → BR/BK lead

- Install the throttle body assembly.
- Measure the sensor input voltage with the engine stopped, and with the connector joined.
- Turn the ignition switch ON.

### Input Voltage at Sensor

**Standard:** 4.75 ~ 5.25 V DC

- Turn the ignition switch OFF.
- ★ If the reading is out of the range, check the wiring (see wiring diagram in this section).
- ★ If the reading is good, check the output voltage of the sensor.

### Output Voltage Inspection

- Measure the output voltage at the ECU in the same way as input voltage inspection. Note the following.  
Digital Voltmeter [A]  
Connectors [B]

**Special Tool - Needle Adapter Set: 57001-1457**

### Main Throttle Sensor Output Voltage Connections to ECU

**Meter (+)** → Y/W lead (terminal 5)

**Meter (-)** → BR/BK lead (terminal 59)

- Start the engine and warm it up thoroughly.
- Check idle speed to ensure throttle opening is correct.

### Idle Speed

**Standard:** 1 100 r/min (rpm)

- ★ If the idle speed is out of the specified range, adjust the idle speed (see Idle Speed Inspection in Periodic Maintenance chapter).
- Turn the ignition switch OFF.
- Measure the output voltage with the engine stopped, and with the connector joined.
- Turn the ignition switch ON.
- Measure the output voltage when the throttle is fully opened or completely closed.

### Output Voltage at ECU

**Standard:** 0.66 ~ 4.62 V DC (at idle throttle opening to full throttle opening)

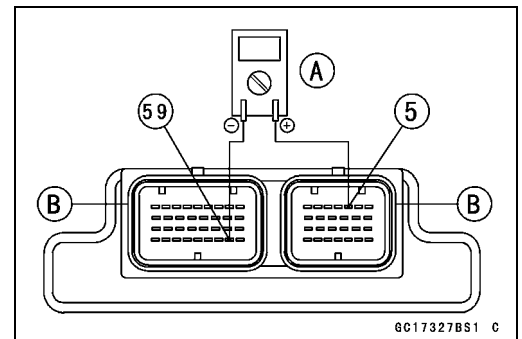

## 3-46 FUEL SYSTEM (DFI)

### Main Throttle Sensor (Service Code 11)

---

#### NOTE

○ *The throttle sensor is operating correctly if the following voltages are obtained:*

- *0.66 VDC (or slightly higher) with the throttle at the idle position.*
- *4.62 VDC (or slightly lower) with the throttle at the fully open position.*

CAUTION
<p><b>Do not remove or adjust the main throttle sensor. It has been adjusted and set with precision at the factory.</b></p> <p><b>Never drop the sensor can especially on a hard surface. A shock to the sensor can damage it.</b></p>

- ★ If the output voltage is within the standard range, check the ECU for a good ground, and power supply (see this chapter). If the ground and power supply are good, replace the ECU.
- ★ If the output voltage is far out of the standard range (e.g. when the wiring is open, the reading is 0 V), check the output voltage again at the sensor connector.



## Main Throttle Sensor (Service Code 11)

- Disconnect the main throttle sensor connector and connect the harness adapter [A] between the harness connector and main throttle sensor connector.
- Connect a digital meter to the harness adapter leads.

**Special Tool - Throttle Sensor Setting Adapter #1: 57001-1400**

### Throttle Sensor Output Voltage

#### Connections to Sensor

**Meter (+)** → Y/W lead

**Meter (-)** → BR/BK lead

- Measure the sensor output voltage with the engine stopped, and with the connector joined.
- Turn the ignition switch ON.
- Measure the output voltage when the throttle is fully opened or completely closed.

#### Output Voltage at Sensor

**Standard:** 0.66 ~ 4.62 V DC (at idle throttle opening to full throttle opening)

### NOTE

○ *The throttle sensor is operating correctly if the following voltages are obtained:*

- 0.66 VDC (or slightly higher) with the throttle at the idle position.
- 4.62 VDC (or slightly lower) with the throttle at the fully open position.

### CAUTION

**Do not remove or adjust the main throttle sensor. It has been adjusted and set with precision at the factory.**  
**Never drop the sensor, especially on a hard surface. A shock to the sensor can damage it.**

### NOTE

○ *The standard voltage marked with an asterisk refers to the value when the voltage reading at the Input Voltage Inspection shows 5V exactly.*

○ *When the input voltage reading shows other than 5V, derive a voltage range as follows.*

*Example:*

*In the case of a input voltage of 4.75 V.*

$$0.66 \times 4.75 \div 5.00 = 0.63 \text{ V}$$

$$4.62 \times 4.75 \div 5.00 = 4.39 \text{ V}$$

*Thus, the valid range is 0.63 ~ 4.39 V*

- After throttle sensor voltage inspection, remove the harness adapter.
- ★ If the reading is out of the standard range, inspect the throttle sensor resistance.
- ★ If the output voltage is normal, check the wiring for continuity (see next diagram).

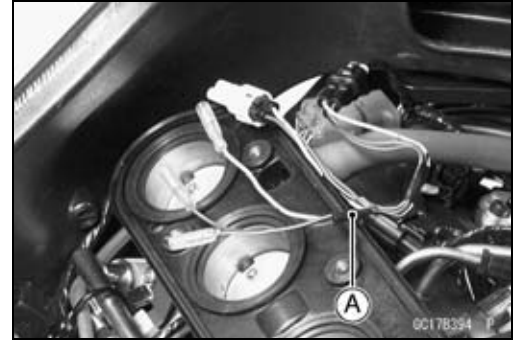

## 3-48 FUEL SYSTEM (DFI)

### Main Throttle Sensor (Service Code 11)

#### Resistance Inspection

- Turn the ignition switch OFF.
- Disconnect the main throttle sensor connector.
- Connect a digital meter [A] to the main throttle sensor connector [B].
- Measure the main throttle sensor resistance.

#### Main Throttle Sensor Resistance

Connections: BL lead [C] ↔ BK lead [D]

Standard: 4 ~ 6 kΩ

- ★ If the reading is out of the range, replace the throttle body assy.
- ★ If the reading is within the range, but the problem still exists, replace the ECU (see this chapter).

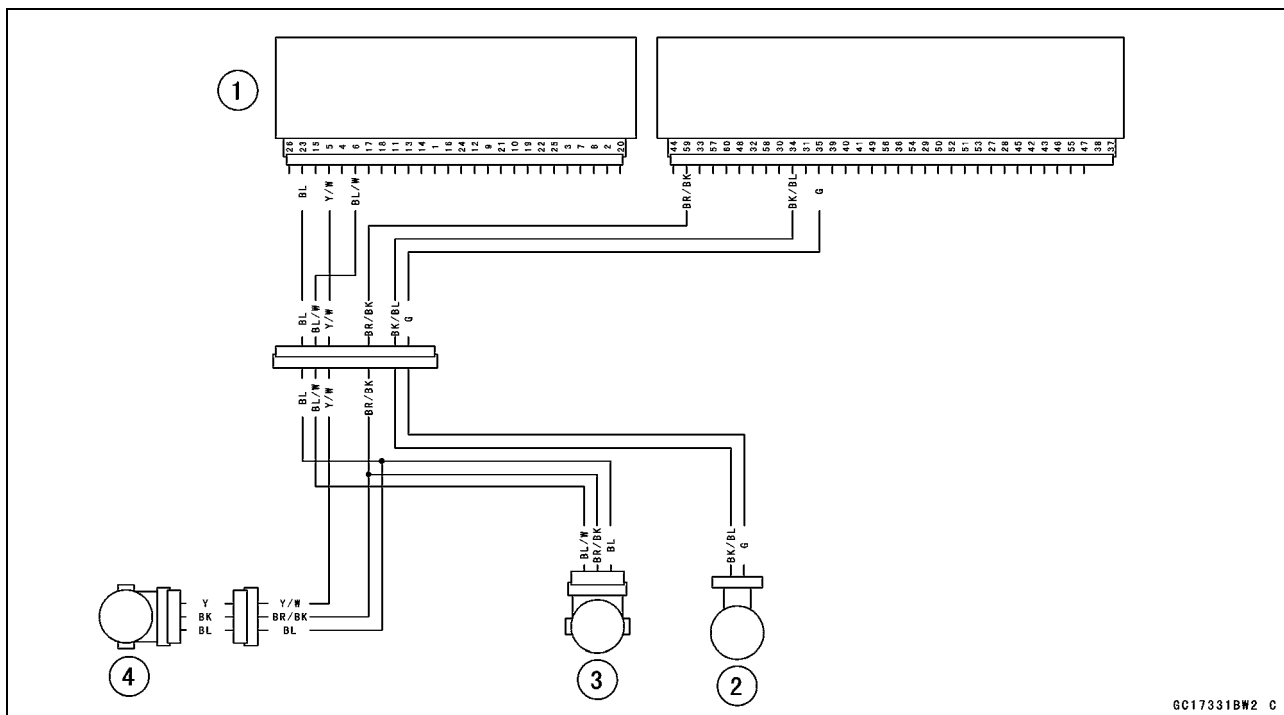
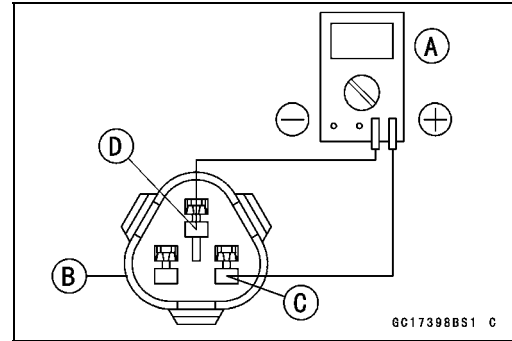

1. ECU
2. Subthrottle Valve Actuator
3. Subthrottle Sensor
4. Main Throttle Sensor

**Inlet Air Pressure Sensor (Service Code 12)**

**CAUTION**

**Never drop the sensor, especially on a hard surface. Such a shock to the part can damage it.**

*Removal*

- Turn the ignition switch off.
- Remove:
  - Air Cleaner Housing (see Air Cleaner Housing Removal)
  - Inlet Air Pressure Sensor Connector [A]
  - Inlet Air Pressure Sensor Screw [B]
  - Inlet Air Pressure Sensor [C]
  - Vacuum Hose [D]

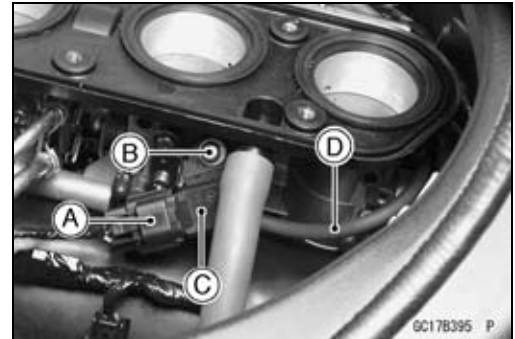

*Installation*

**NOTE**

○The inlet air pressure sensor is the same part as the atmospheric sensor except that the sensor has a vacuum hose and different wiring.

- Install:
    - Vacuum Hose
    - Inlet Air Pressure Sensor
- Torque - Inlet Air Pressure Sensor Screw: 3.5 N·m (0.36 kgf·m, 31 in·lb)**

*Input Voltage Inspection*

**NOTE**

○Be sure the battery is fully charged.  
 ○The inspection is the same as "Input Voltage Inspection" of the throttle sensor and the atmospheric pressure sensor.

- Turn the ignition switch OFF.
- Remove the ECU (see ECU Removal). Do not disconnect the ECU connectors.
- Connect a digital voltmeter [A] to the connector [B], with the needle adapter set.

**Special Tool - Needle Adapter Set: 57001-1457**

**Inlet Air Pressure Sensor Input Voltage Connections to ECU**

**Meter (+) → BL lead (terminal 23)**

**Meter (-) → BR/BK lead (terminal 59)**

- Measure the input voltage with the engine stopped, and with the connectors joined.
- Turn the ignition switch ON.

**Input Voltage at ECU**

**Standard: 4.75 ~ 5.25 V DC**

- ★ If the reading is less than the standard range, check the ECU for its ground, and power supply (see this chapter). If the ground and power supply are good, replace the ECU.

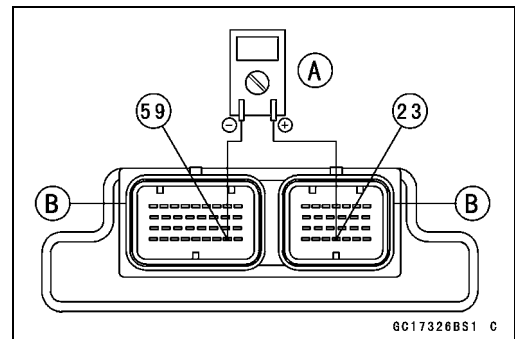

## 3-50 FUEL SYSTEM (DFI)

### Inlet Air Pressure Sensor (Service Code 12)

- ★ If the reading is within the standard range, and check the input voltage again at the sensor connector.
- Remove the air cleaner housing (see Air Cleaner Housing Removal).
- Disconnect the inlet air pressure sensor connector and connect the harness adapter [A] between the sub harness connector and inlet air pressure sensor connector.
- Connect a digital meter to the harness adapter leads. [B] Inlet Air Pressure Sensor

**Special Tool - Sensor Harness Adapter: 57001-1561**

#### Inlet Air Pressure Sensor Input Voltage

##### Connections to Sensor

Meter (+) → BL lead [C]

Meter (-) → BR/BK lead [D]

- Measure the input voltage with the engine stopped.
- Turn the ignition switch ON.

##### Input Voltage at Sensor Connector

**Standard: 4.75 ~ 5.25 V DC**

- ★ If the reading is out of the standard range, check the wiring (see wiring diagram in this section).
- ★ If the reading is good, the input voltage is normal. Check the output voltage.
- Turn the ignition switch OFF.

#### Output Voltage Inspection

- Measure the output voltage at the ECU in the same way as input voltage inspection. Note the following.

##### Inlet Air Pressure Sensor Output Voltage

##### Connections to ECU

Meter (+) → Y/BL lead (terminal 17)

Meter (-) → BR/BK lead (terminal 59)

##### Output Voltage at ECU

**Usable Range: 3.80 ~ 4.20 V DC at the standard atmospheric pressure (101.32 kPa, 76 cmHg abs.)**

#### NOTE

- The output voltage changes according to the local atmospheric pressure.
  - The vacuum sensor output voltage is based on a nearly perfect vacuum in the small chamber of the sensor. So, the sensor indicates absolute vacuum pressure.
- ★ If the output voltage is within the usable range, check the ECU for its ground, and power supply (see this chapter). If the ground and power supply are good, replace the ECU.

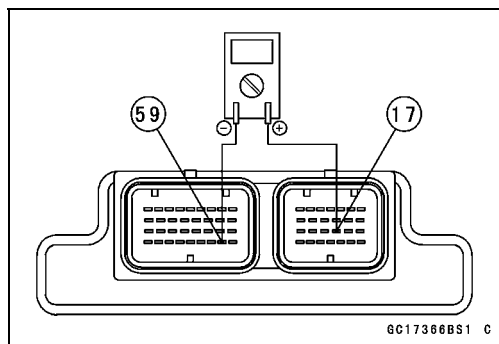
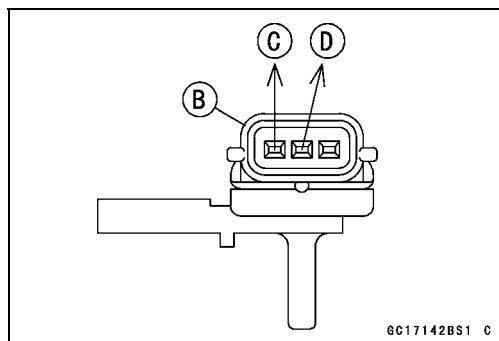
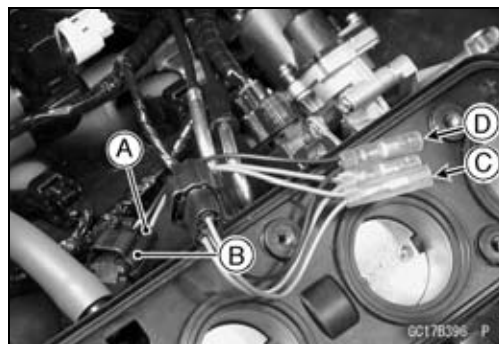

**Inlet Air Pressure Sensor (Service Code 12)**

★ If the output voltage is far out of the usable range, check the output voltage again at the sensor connector [A] (when the lead is open, the output voltage is about 1.8 V).

- Connect a digital meter to the harness adapter leads. [B] Inlet Air Pressure Sensor

**Special Tool - Sensor Harness Adapter: 57001-1561**

**Inlet Air Pressure Sensor Output Voltage Connections to Sensor**

Meter (+) → Y/BL lead [C]

Meter (-) → BR/BK lead [D]

**Output Voltage at Sensor Connector**

**Usable Range: 3.80 ~ 4.20 V DC at the standard atmospheric pressure (101.32 kPa or 76 cmHg absolute)**

★ If the output voltage is normal, check the wiring for continuity (see next diagram).

★ If the output voltage is out of the usable range, replace the sensor.

- Turn the ignition switch OFF.
- Remove the throttle sensor harness adapter.

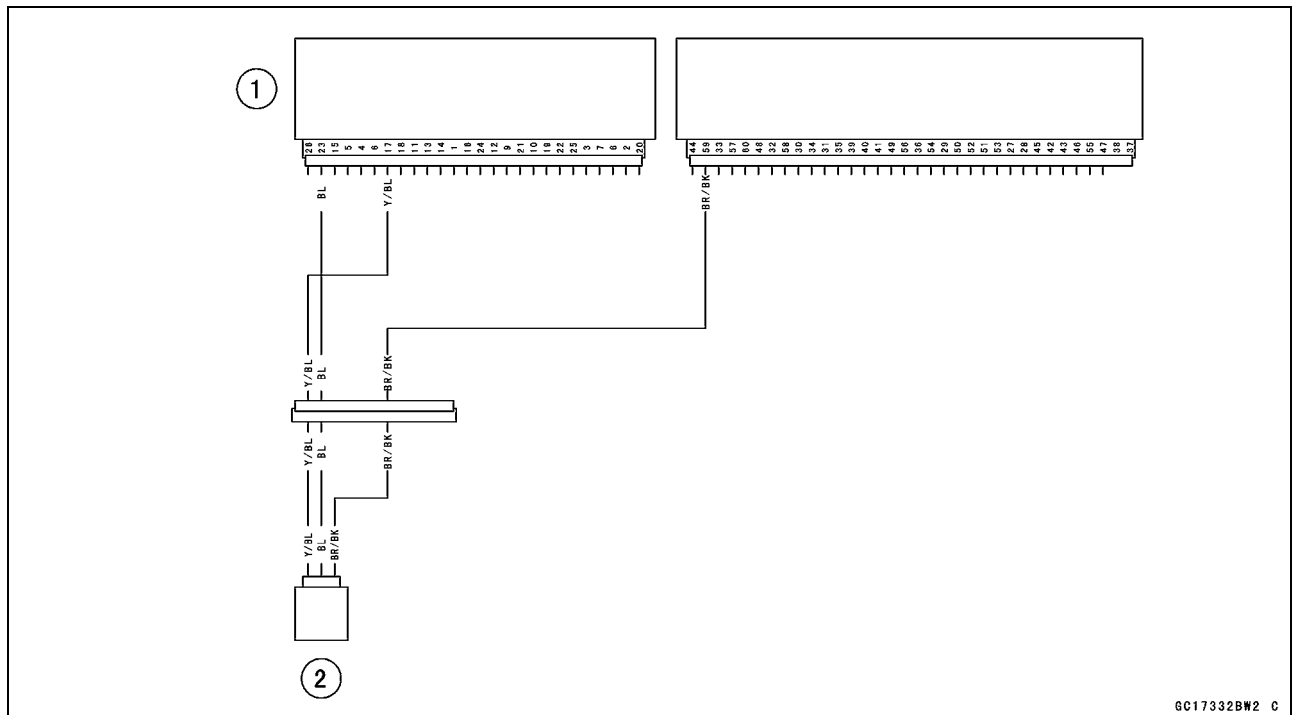
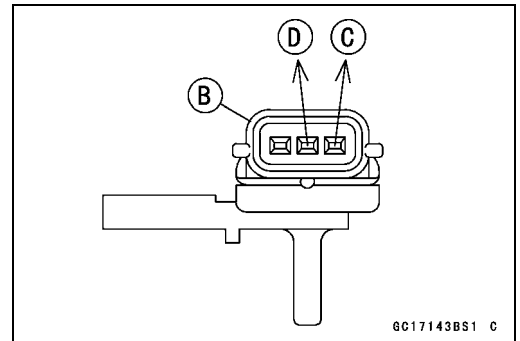
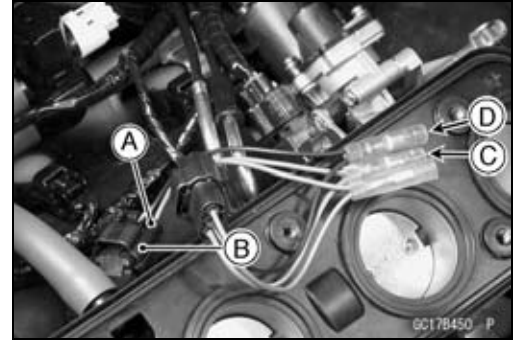

1. ECU
2. Inlet Air Pressure Sensor

★ If you need to check the inlet air pressure sensor for vacuum other than 76 cmHg (abs), check the output voltage as follows:

## 3-52 FUEL SYSTEM (DFI)

### Inlet Air Pressure Sensor (Service Code 12)

- Remove the inlet air pressure sensor [A] and disconnect the vacuum hose from the sensor.
- Do not disconnect the sensor connector.
- Connect an auxiliary hose [B] to the inlet air pressure sensor.
- Temporarily install the inlet air pressure sensor.
- Connect a commercially available digital meter [C], vacuum gauge [D], and the fork oil level gauge [E] to the inlet air pressure sensor.

**Special Tools - Fork Oil Level Gauge: 57001-1290**  
**Sensor Harness Adapter: 57001-1561**

#### Inlet Air Pressure Sensor Output Voltage Connection to Sensor

**Meter (+) → Y/BL lead**

**Meter (-) → BR/BK lead**

- Turn the ignition switch ON.
- Measure the inlet air pressure sensor output voltage from various vacuum readings, while pulling the handle of the fork oil level gauge.
- Check the inlet air pressure sensor output voltage, using the following formula and chart.

Suppose:

Pg : Vacuum Pressure (gauge) of Throttle Assy

PI : Local Atmospheric Pressure (absolute) measured by a barometer

Pv : Vacuum Pressure (absolute) of Throttle Assy

Vv : Sensor Output Voltage (v)

then

$$Pv = PI - Pg$$

For example, suppose the following data is obtained:

Pg = 8 cmHg (vacuum gauge reading)

PI = 70 cmHg (barometer reading)

Vv = 3.2 V (digital volt meter reading)

then

$$Pv = 70 - 8 = 62 \text{ cmHg (abs)}$$

Plot this Pv (62 cmHg) at a point [1] on the chart and draw a vertical line through the point. Then, you can get the usable range [2] of the sensor output voltage.

Usable range = 3.08 ~ 3.48 V

Plot Vv (3.2 V) on the vertical line. → Point [3].

**Results: In the chart, Vv is within the usable range and the sensor is normal.**

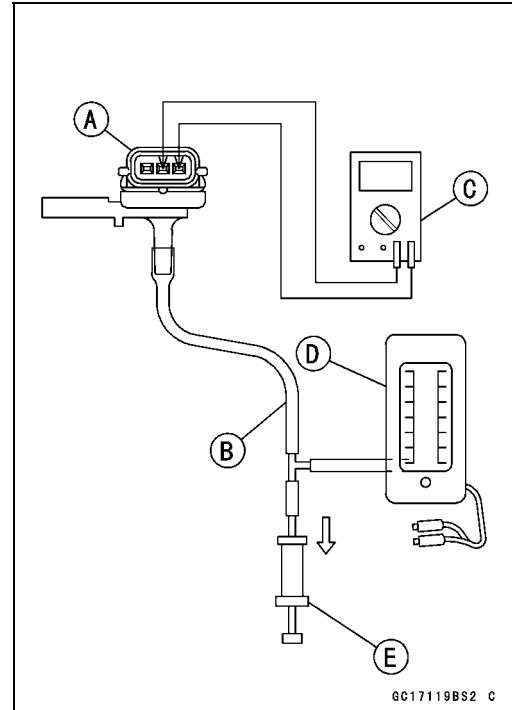

Inlet Air Pressure Sensor (Service Code 12)

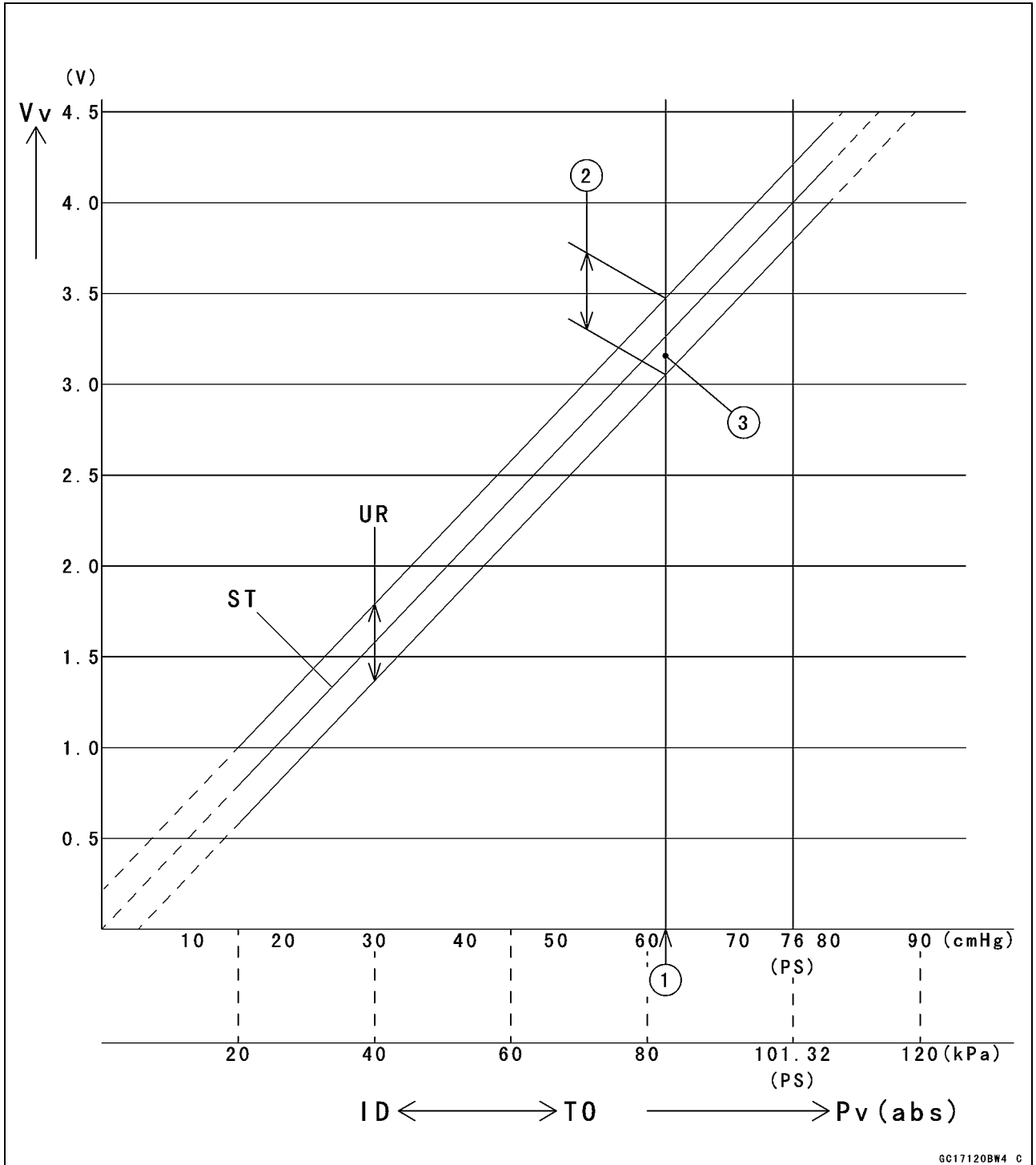

$V_v$ : Inlet Air Pressure Sensor Output Voltage (V) (Digital Meter Reading)

$P_v$ : Throttle Vacuum Pressure (absolute)

Ps: Standard Atmospheric Pressure (absolute)

ID: Idling

TO: Throttle Full Open

ST: Standard of Sensor Output Voltage (v)

UR: Usable Range of Sensor Output Voltage (v)

## 3-54 FUEL SYSTEM (DFI)

### Inlet Air Temperature Sensor (Service Code 13)

#### Removal/Installation

#### CAUTION

Never drop the sensor, especially on a hard surface. Such a shock to the sensor can damage it.

- Remove the fuel tank (see Fuel Tank Removal).
- Disconnect the connector [A] from the inlet air temperature sensor.
- Pull out the inlet air temperature sensor [B].
  
- Install the inlet air temperature sensor [A] in the grommet [B].

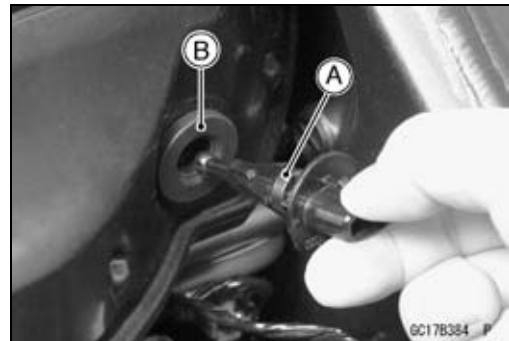
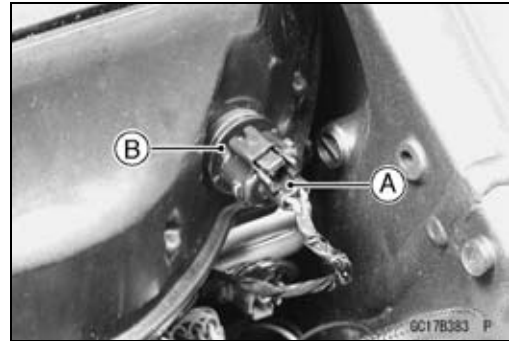

#### Output Voltage Inspection

#### NOTE

○Be sure the battery is fully charged.

- Remove the ECU (see this chapter). Do not disconnect the ECU connectors.
- Connect a digital voltmeter to the ECU connector, using needle adapter set.

**Special Tool - Needle Adapter Set: 57001-1457**

#### Inlet Air Temperature Sensor Output Voltage Connections to ECU Connector

**Meter (+) → Y lead (terminal 11)**

**Meter (-) → BR/BK lead (terminal 59)**

- Measure the sensor output voltage with the engine stopped and the connector joined.
- Turn the ignition switch ON.

#### Output Voltage at ECU

**Standard: about 2.25 ~ 2.50 V at inlet air temperature 20°C (68°F)**

#### NOTE

○The output voltage changes according to the inlet air temperature.

- Turn the ignition switch OFF.

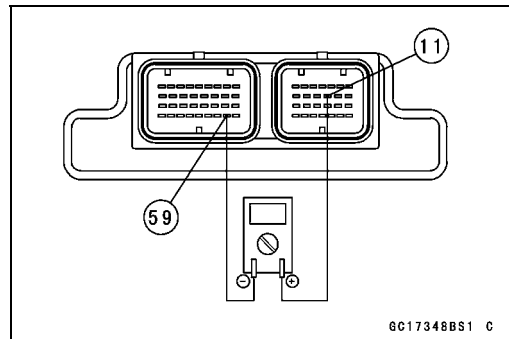



**Inlet Air Temperature Sensor (Service Code 13)**

- ★ If the output voltage is out of the specified, check the ECU for its ground, and power supply (see ECU section in this chapter). If the ground and power supply are good, replace the ECU.
- ★ If the output voltage is far out of the specified (e.g. when the wiring is open, the voltage is about 4.6 V), remove the fuel tank cover, and check the wiring (see next diagram).
- Remove the needle adapter set, and apply silicone sealant to the seals of the connector for waterproofing.

**Silicone Sealant (Kawasaki Bond: 56019-120)**

**- Seals of ECU Connectors**

- ★ If the wiring is good, check the sensor resistance.

**Sensor Resistance Inspection**

- Remove the inlet air temperature sensor (see this section).
- Suspend the sensor [A] in a container of machine oil so that the heat-sensitive portion is submerged.
- Suspend a thermometer [B] with the heat-sensitive portion [C] located in almost the same depth with the sensor.

**NOTE**

○ *The sensor and thermometer must not touch the container side or bottom.*

- Place the container over a source of heat and gradually raise the temperature of the oil while stirring the oil gently for even temperature.
- Using a digital meter, measure the internal resistance of the sensor across the terminals at the temperatures shown in the table.

**Inlet Air Temperature Sensor Resistance**

**Standard: 2.09 ~ 2.81 kΩ at 20°C (68°F) about 0.322 kΩ at 80°C (176°F) (reference valve)**

- ★ If the measurement is out of the range, replace the sensor.
- ★ If the measurement is within the specified, replace the ECU.

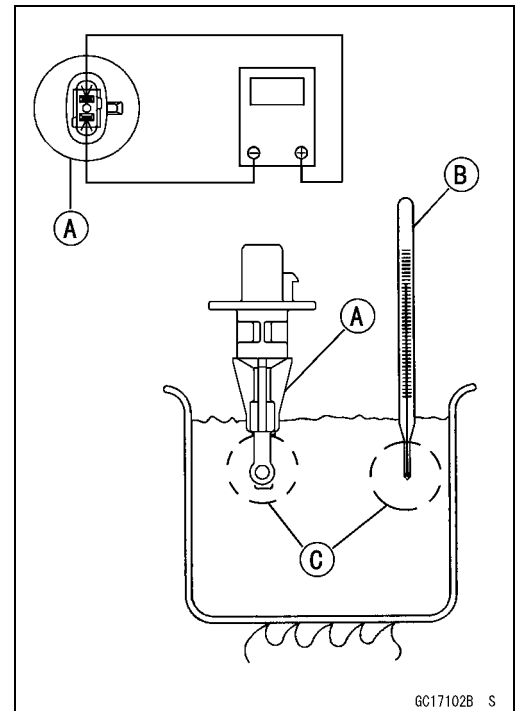

# 3-56 FUEL SYSTEM (DFI)

## Inlet Air Temperature Sensor (Service Code 13)

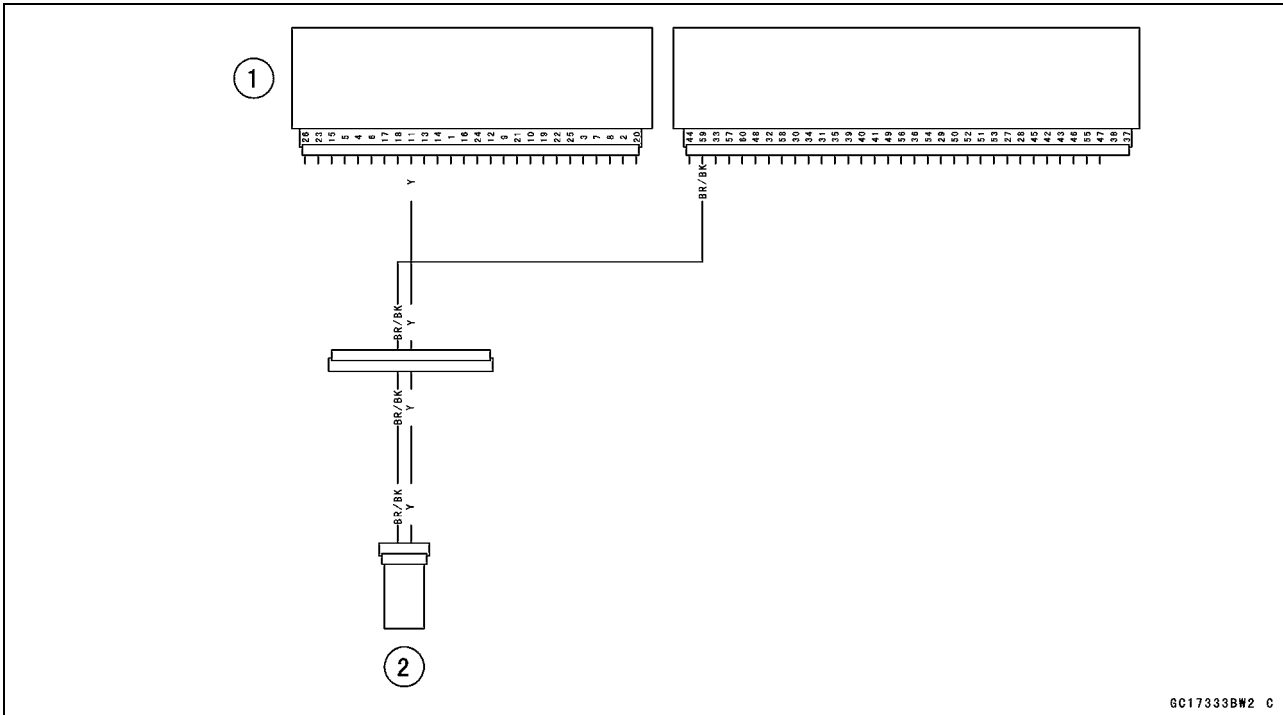

6C17333BW2 C

- 1. ECU
- 2. Inlet Air Temperature Sensor

**Water Temperature Sensor (Service Code 14)**

*Removal/Installation*

<b>CAUTION</b>
<b>Never drop the sensor, especially on a hard surface. Such a shock to the sensor can damage it.</b>

- Drain the coolant (see Coolant Change in the Periodic Maintenance chapter).
- Remove the air cleaner housing (see Air Cleaner Housing Removal).
- Disconnect the connectors [A], and remove the band [B].
- Pull off the throttle body upward (see Throttle Body Assy Removal).
- Remove:
  - Water Temperature Sensor [A]
- Install the water temperature sensor.
  - Silicone Sealant (Kawasaki Bond: 56019-120)**
  - Threads of Water Temperature Sensor
  - Torque - Water Temperature Sensor: 25 N·m (2.5 kgf·m, 18 ft·lb)**
- Fill the engine with coolant and bleed the air from the cooling system (see Coolant Filling in the Cooling System chapter).

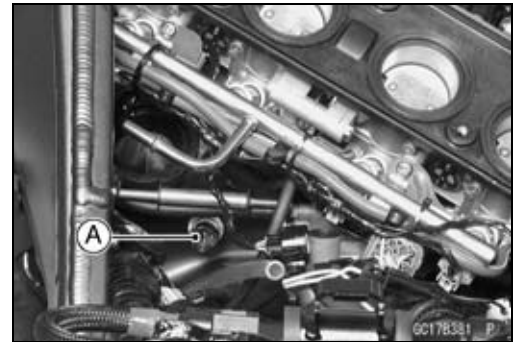
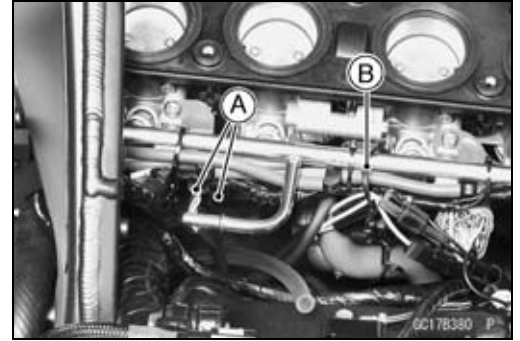

*Output Voltage Inspection*

**NOTE**

○Be sure the battery is fully charged.

- Remove the ECU (see ECU Removal). Do not disconnect the connectors.
- Connect a digital voltmeter [A] to the ECU connectors [B], with the needle adapter set.

**Special Tool - Needle Adapter Set: 57001-1457**

**Water Temperature Sensor Output Voltage Connections to ECU**

**Meter (+) → O lead (terminal 13)**

**Meter (-) → BR/BK lead (terminal 59)**

- Measure the sensor output voltage with the engine stopped and the connector joined.
- Turn the ignition switch ON.

**Output Voltage at ECU**

**Standard:                    about 2.80 ~ 2.97 V at 20°C (68°F)**

**NOTE**

○The output voltage changes according to the coolant temperature in the engine.

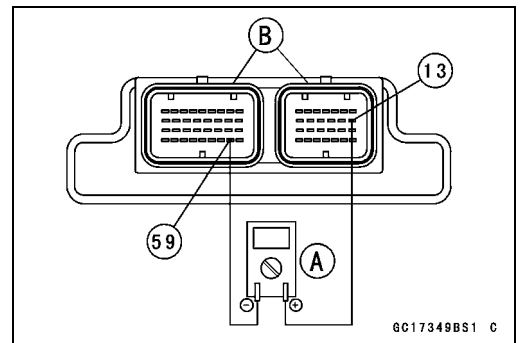



**Atmospheric Pressure Sensor (Service Code 15)**

**CAUTION**

**Never drop the sensor, especially on a hard surface. Such a shock to the sensor can damage it.**

*Removal*

- Turn the ignition switch off.
- Remove:
  - Seat (see Frame chapter)
  - Atmospheric Pressure Sensor Connector [A]
  - Damper [B]
  - Atmospheric Pressure Sensor [C]

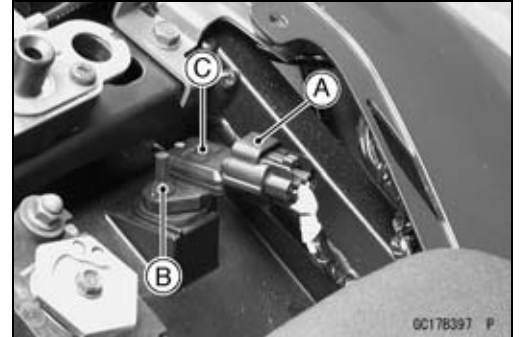

*Installation*

**NOTE**

○The atmospheric pressure sensor is the same part as the inlet air pressure sensor except that the inlet air pressure sensor has a inlet air pressure hose and different wiring.

- Installation is reverse of removal.

*Input Voltage Inspection*

**NOTE**

○Be sure the battery is fully charged.  
 ○The inspection is the same as "Input Voltage Inspection" of the throttle sensor and the inlet air pressure sensor.

- Turn the ignition switch OFF.
- Remove the ECU (see this chapter). Do not disconnect the ECU connectors.
- Connect a digital voltmeter [A] to the connector [B], with the needle adapter set.

**Special Tool - Needle Adapter Set: 57001-1457**

**Atmospheric Pressure Sensor Input Voltage Connections to ECU**

- Meter (+) → BL lead (terminal 23)**
- Meter (-) → BR/BK lead (terminal 59)**

- Measure the input voltage with the engine stopped, and with the connectors joined.
- Turn the ignition switch ON.

**Input Voltage at ECU**

**Standard: 4.75 ~ 5.25 V DC**

- ★If the reading of input voltage is less than the standard range, check the ECU for its ground, and power supply (see this chapter). If the ground and power supply are good, replace the ECU.

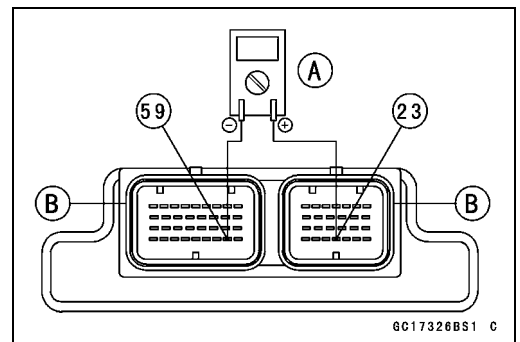

## 3-60 FUEL SYSTEM (DFI)

### Atmospheric Pressure Sensor (Service Code 15)

★If the reading is within the standard range, remove the seat cover, and check the input voltage again at the sensor connector.

- Remove the air cleaner housing (see Air Cleaner Housing Removal).
- Disconnect the atmospheric pressure sensor connector and connect the harness adapter [A] between the main harness connector and pressure sensor connector.
- Connect a digital meter to the harness adapter leads. [B] Atmospheric Pressure Sensor

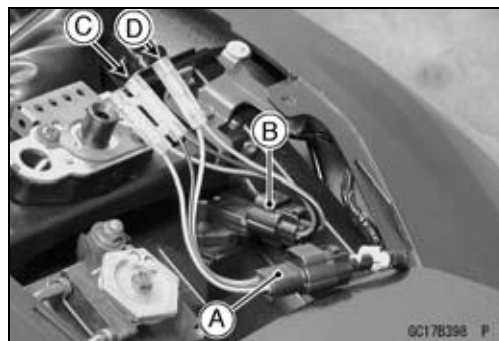

**Special Tool - Sensor Harness Adapter: 57001-1561**

#### Atmospheric Pressure Sensor Input Voltage Connections to Sensor

Meter (+) → BL lead [C]

Meter (-) → BR/BK lead [D]

- Measure the input voltage with the engine stopped, and with the connector joined.
- Turn the ignition switch ON.

#### Input Voltage at Sensor Connector

Standard: 4.75 ~ 5.25 V DC

- ★If the reading is out of the standard range, check the wiring (see wiring diagram in this section).
- ★If the reading is good, the input voltage is normal. Check the output voltage.
- Turn the ignition switch OFF.

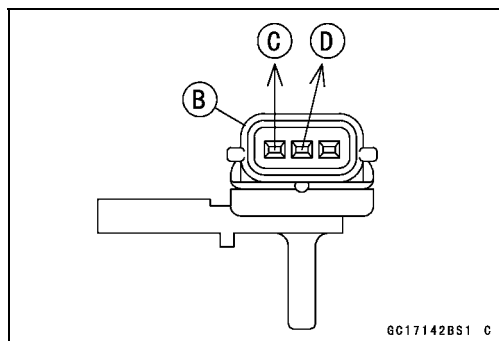

#### Output Voltage Inspection

- Measure the output voltage at the ECU in the same way as input voltage inspection. Note the following.

Digital Meter [A]

ECU Connector [B]

#### Atmospheric Pressure Sensor Output Voltage Connections to ECU

Meter (+) → G/W lead (terminal 18)

Meter (-) → BR/BK lead (terminal 59)

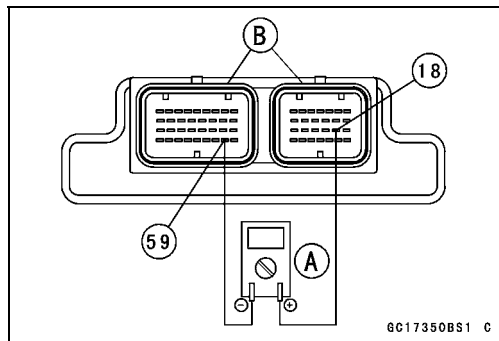

#### Output Voltage

Usable Range: 3.80 ~ 4.20 V DC at the standard atmospheric pressure (101.32 kPa, 76 cmHg abs.)

#### NOTE

- The output voltage changes according to the local atmospheric pressure.
  - The atmospheric sensor output voltage is based on a nearly perfect vacuum in the small chamber of the sensor. So, the sensor indicates absolute atmospheric pressure.
- ★If the output voltage is within the usable range, check the ECU for its ground, and power supply (see this chapter). If the ground and power supply are good, replace the ECU.

**Atmospheric Pressure Sensor (Service Code 15)**

★ If the output voltage is far out of the usable range, remove the fuel tank, and check the output voltage at the sensor connector [A] (when the wiring is open, the output voltage is about 1.8 V).

- Connect a digital meter [A] to the harness adapter leads. [B] Atmospheric Pressure Sensor

**Special Tool - Sensor Harness Adapter: 57001-1561**

**Atmospheric Pressure Sensor Output Voltage Connections to Sensor**

Meter (+) → G/W lead [C]

Meter (-) → BR/BK lead [D]

**Output Voltage at Sensor**

**Usable Range: 3.80 ~ 4.20 V DC at the standard atmospheric pressure (101.32 kPa, 76 cmHg abs)**

★ If the output voltage is normal, check the wiring for continuity (see next diagram).

★ If the output voltage is out of the usable range, replace the sensor.

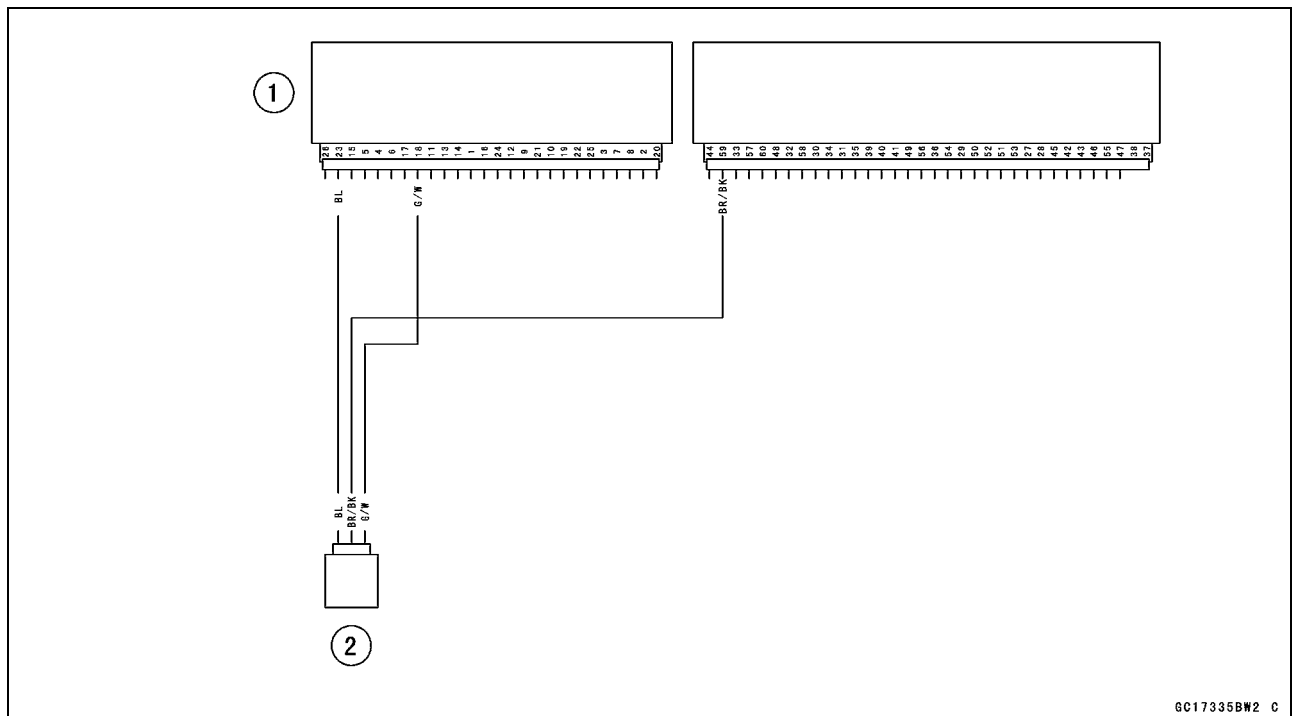
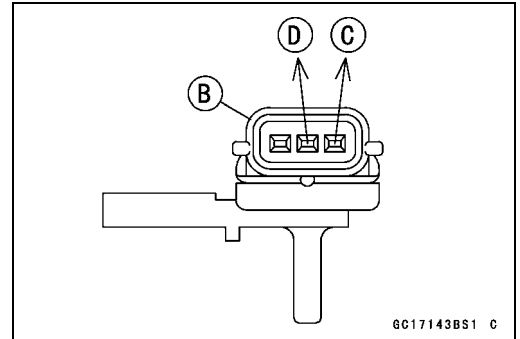
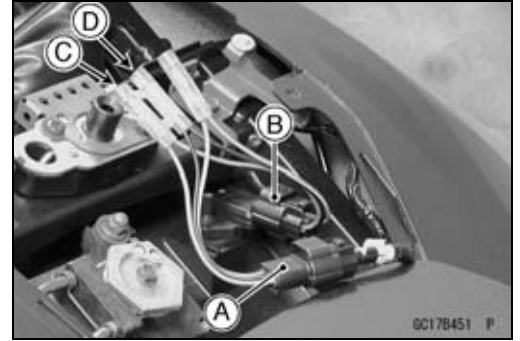

1. ECU
2. Atmospheric Pressure Sensor

★ If you need to check the atmospheric pressure sensor for various altitudes other than sea level, check the output voltage as follows:

- Determine the local altitude (elevation).

### 3-62 FUEL SYSTEM (DFI)

#### Atmospheric Pressure Sensor (Service Code 15)

- ★If you know the local atmospheric pressure using a barometer, substitute the atmospheric pressure for throttle vacuum pressure in the inlet air pressure sensor chart (see intake Air Pressure Sensor section in this chapter). And get the usable range of the atmospheric pressure sensor output voltage and check if output voltage is within the standard or not in the same way as Output Voltage Inspection of the inlet air pressure sensor.
- ★If you know the local altitude, use the following chart.

#### Atmospheric Pressure/Altitude Relationship

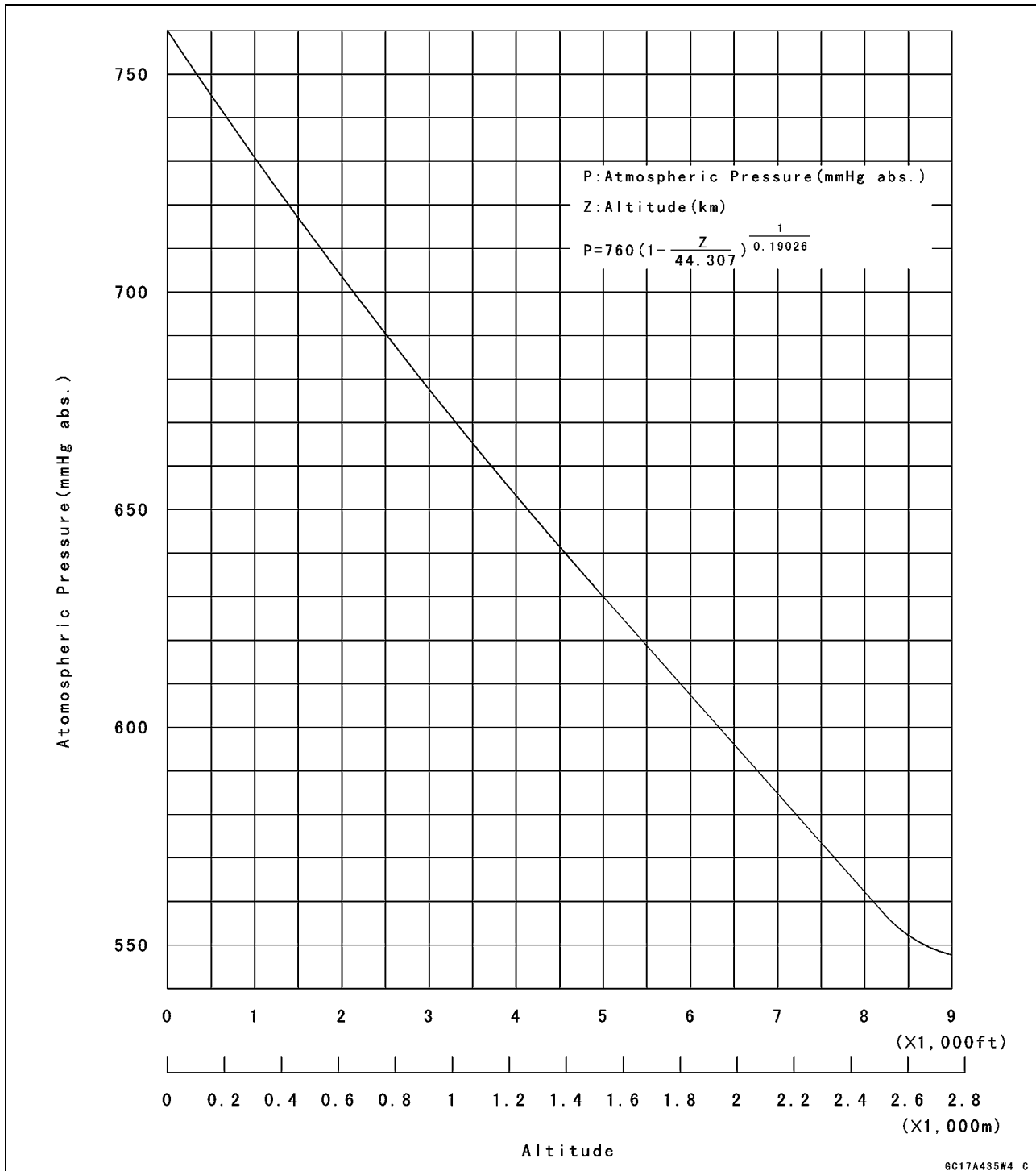



## Crankshaft Sensor (Service Code 21)

### Crankshaft Sensor Removal/Installation

- See the Ignition System section in the Electrical System chapter.

### Crankshaft Sensor Inspection

- The crankshaft has no power source, and when the engine stops, the crankshaft generates no signals.
- Crank the engine and measure the peak voltage of the crankshaft sensor (see Electrical System chapter) in order to check the sensor.
- Check the wiring for continuity, using the following diagram.

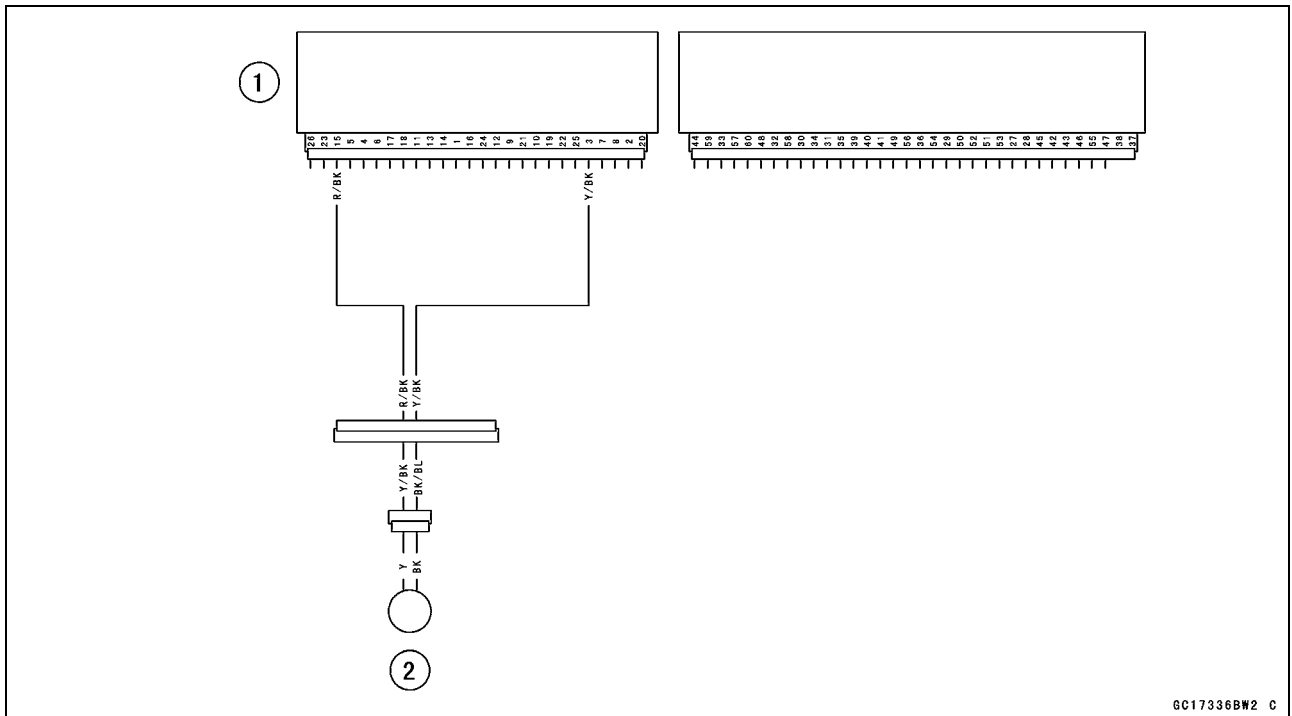

1. ECU
2. Crankshaft Sensor

## 3-64 FUEL SYSTEM (DFI)

### Camshaft Position Sensor (Service Code 23)

#### Camshaft Position Sensor Removal/Installation

##### 1. Inspection starts.

- The camshaft position sensor detects the position of the camshaft, and distinguishes the cylinder.
- See the Ignition system section in the Electric System chapter.

The camshaft position sensor detects the position of the camshaft, and distinguishes the cylinder.

- See the Ignition system section in the Electric System chapter.

#### Camshaft Position Sensor Inspection

- The camshaft position sensor have no power source, and when the engine stops, the camshaft position sensor generates no signal.
- Crank the engine and measure the peak voltage of the camshaft position sensor (see Electrical System chapter) in order to check the sensor.
- Check the wiring for continuity, using the following diagram.

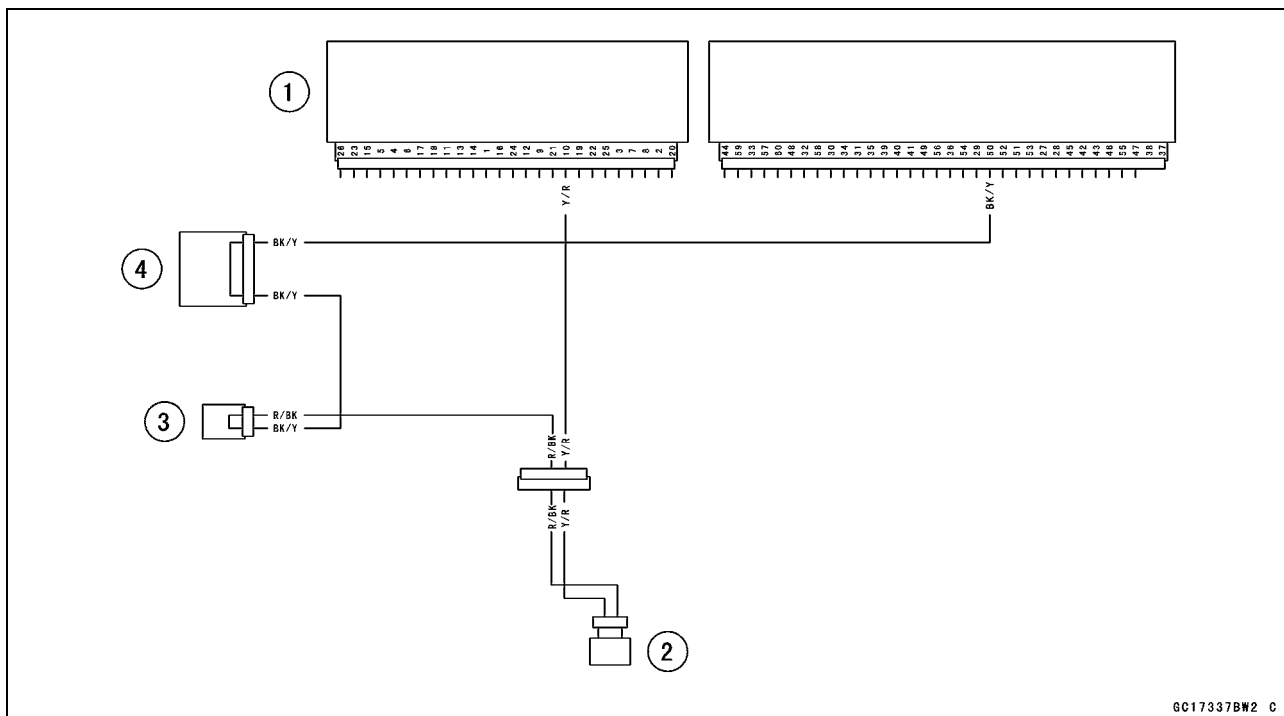

1. ECU
2. Camshaft Position Sensor
3. Joint Connector 1
4. Joint Connector 2

## Speed Sensor (Service Code 24)

### Speed Sensor Removal/Installation

- See the Switches and Sensors section in the Electrical System chapter.

### Speed Sensor Inspection

- See the Switches and Sensors section in the Electrical System chapter.

### Input Voltage Inspection

#### NOTE

○ Be sure the battery is fully charged.

- Turn the ignition switch OFF.
- Remove the left middle fairing (see Frame chapter).
- Disconnect the speed sensor connector [A] and connect the harness adapter [B] between the harness connector and speed sensor connector.
- Connect a digital meter to the harness adapter leads.

**Special Tool - Throttle Sensor Setting Adapter #1: 57001-1400**

#### Speed Sensor Input Voltage Connector to Sensor

**Meter (+) → P lead [C]**

**Meter (-) → BK lead [D]**

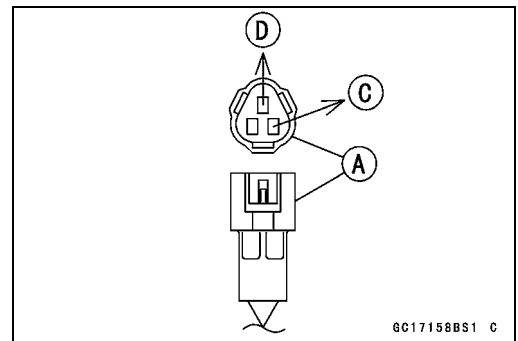
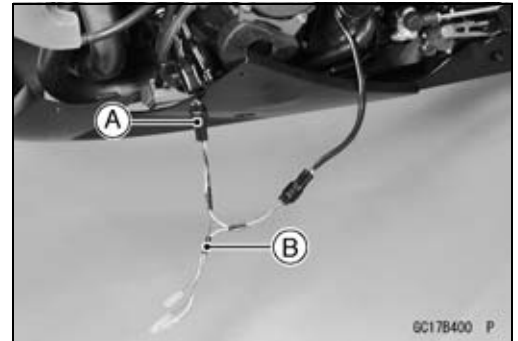

- Measure the sensor input voltage with the engine stopped, and with the connector joined.
- Turn the ignition switch ON.

#### Input Voltage at Sensor

**Standard: About 9 ~ 11 V DC**

★ If the reading is out of the range, check the wiring (see wiring diagram in this section), and meter (see Electrical System chapter).

★ If the reading is good, check the output voltage.

- Turn the ignition switch OFF.

### Output Voltage Inspection

- Before this inspection, inspect the input voltage (see Input Voltage Inspection).

#### NOTE

○ Be sure the battery is fully charged.

- Turn the ignition switch OFF.

## 3-66 FUEL SYSTEM (DFI)

### Speed Sensor (Service Code 24)

- Disconnect the speed sensor connector [A] and connect the harness adapter [B] between the harness connector and speed sensor connector.
- Connect a digital meter to the harness adapter leads.

**Special Tool - Throttle Sensor Setting Adapter #1: 57001-1400**

#### Speed Sensor Output Voltage Connections to Sensor

**Meter (+) → BL/Y lead [C]**

**Meter (-) → BK lead [D]**

- Measure the sensor output voltage with the engine stopped, and with the connector joined.
- Turn the ignition switch ON.

#### Output Voltage at Sensor

**Standard: About 0.05 ~ 0.07 V DC**

#### NOTE

○If you can rotate the engine sprocket, the output voltage will be raise.

- ★If the reading is out of the range, check the speed sensor (see Electrical System chapter) and the wiring to ECU (see wiring diagram in this section).
- ★If the reading, speed sensor and wiring are good, replace the ECU.

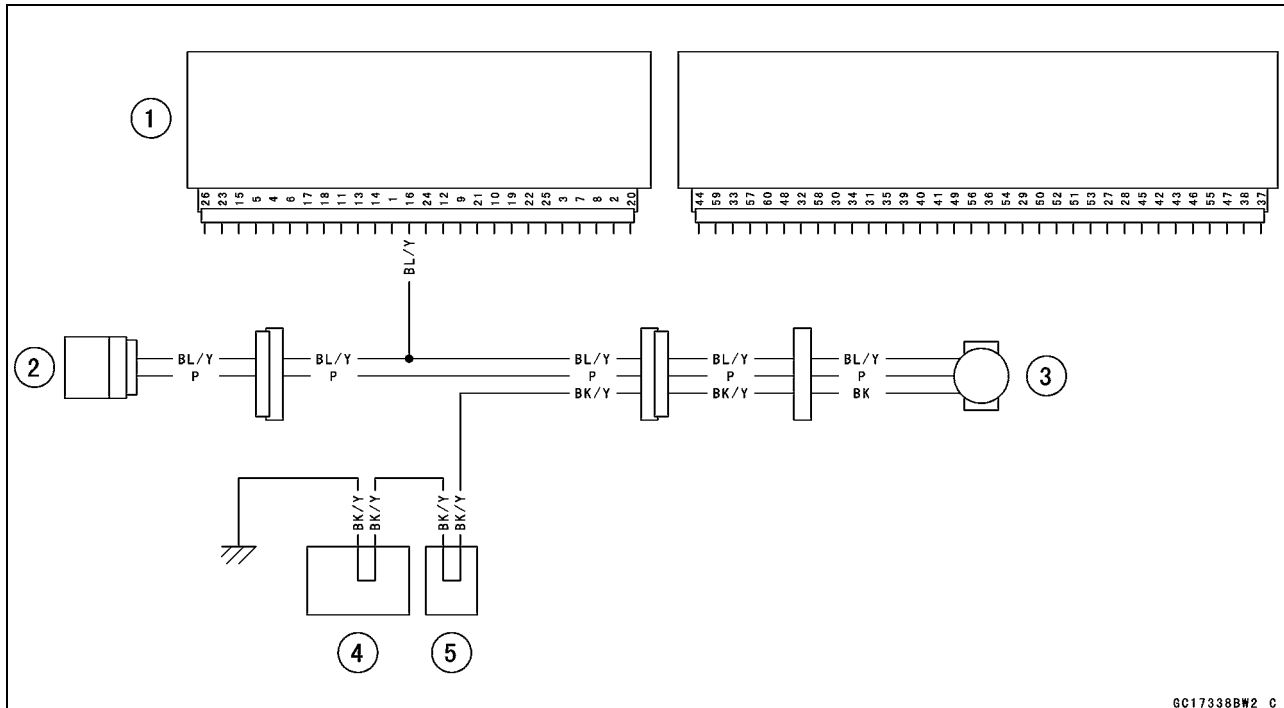
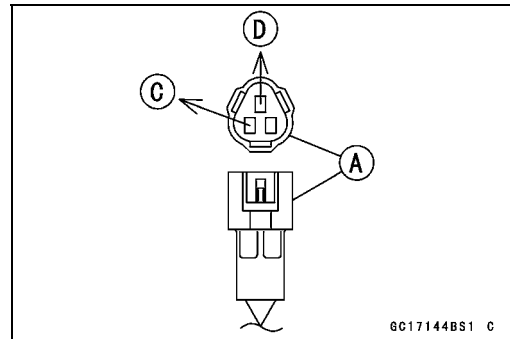
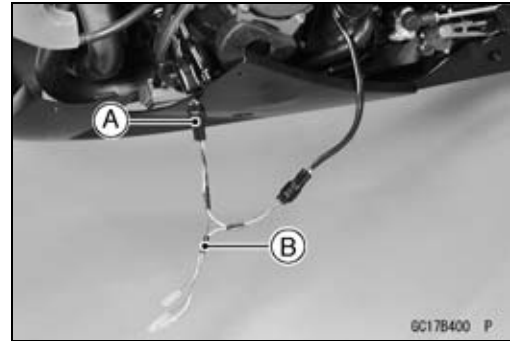

1. ECU
2. Meter Assembly
3. Speed Sensor
4. Joint Connector 1
5. Joint Connector 2

## Gear Position Switch (Service Code 25)

### Gear Position Switch Removal/Installation

- See the Switches and Sensors section in the Electrical System chapter.

### Gear Position Switch Inspection

- See the Switches and Sensors section in the Electrical System chapter.

### Input Voltage Inspection

#### NOTE

○ Be sure the battery is fully charged.

- Turn the ignition switch OFF.
- Remove the ECU (see ECU Removal). Do not disconnect the ECU connectors.
- Connect a digital meter [A] to the connector, with the needle adapter set.

**Special Tool - Needle Adapter Set: 57001-1457**

### Gear Position Switch Input Voltage at 1 ~ 6 Gear Positions Connector to ECU

**Meter (+) → W/Y (terminal 12)**

**Meter (-) → Engine Ground**

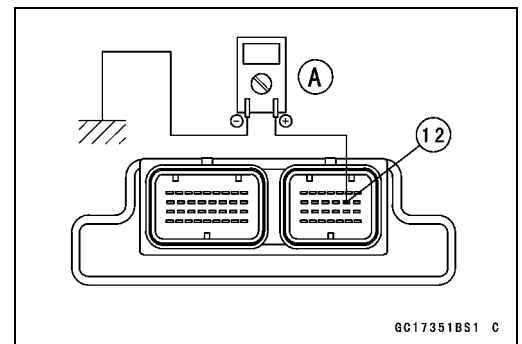

- Measure the switch input voltage with the engine stopped, and with the connector joined.
- Turn the ignition switch ON.

### Input Voltage at 1 ~ 6 Gear Positions

#### Standard:

1st	About 3.0 V
2nd	About 2.5 V
3rd	About 2.0 V
4th	About 1.5 V
5th	About 1.1 V
6th	About 0.7 V

- ★ If the reading is out of the range, check the gear position switch (see Electrical System chapter).
- ★ If the switch is good, check the ECU for its ground and power supply (see this chapter). If the ground and power supply are good, replace the ECU.
- Turn the ignition switch OFF.

# 3-68 FUEL SYSTEM (DFI)

## Gear Position Switch (Service Code 25)

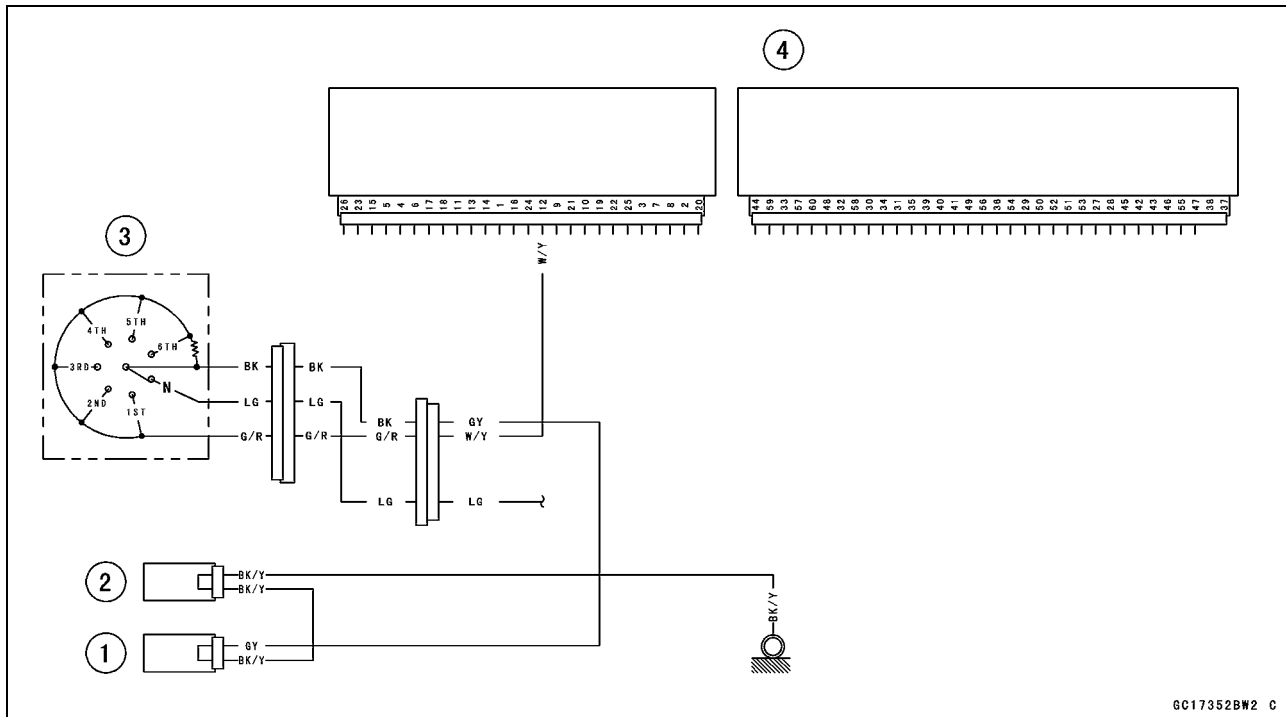

6C17352BW2 C

- 1. Joint Connector 1
- 2. Joint Connector 2
- 3. Gear Position Switch
- 4. ECU

**Vehicle-down-sensor (Service Code 31)**

This sensor has a weight [A] with two magnets inside, and sends a signal to the ECU. But when the motorcycle banks 60 ~ 70° or more to either side (in fact falls down), the weight turns and shuts off the signal. The ECU senses this change, and stops the fuel pump, the fuel injectors, and the ignition system.

Hall IC [B]

When the motorcycle is down, the ignition switch is left ON. If the starter button is pushed, the electric starter turns but the engine doesn't start. To start the engine again, raise the motorcycle, turn the ignition switch OFF, and then ON. When the ignition switch is turned ON, current flows through the latch-up circuit and the transistor in the circuit is turned ON to unlock the latch-up circuit.

Vehicle-down-sensor [A]

Ground Terminal BR/BK [B]

Output Terminal Y/G [C]

Power Source Terminal BL [D]

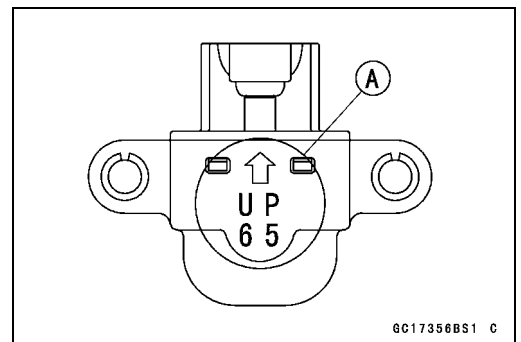
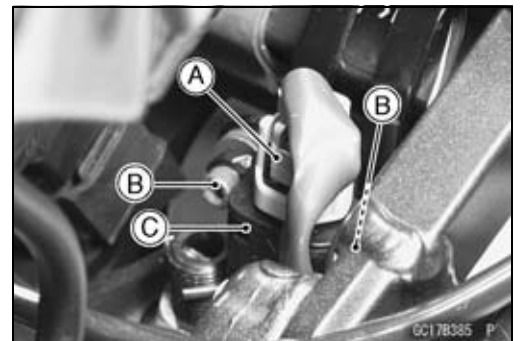
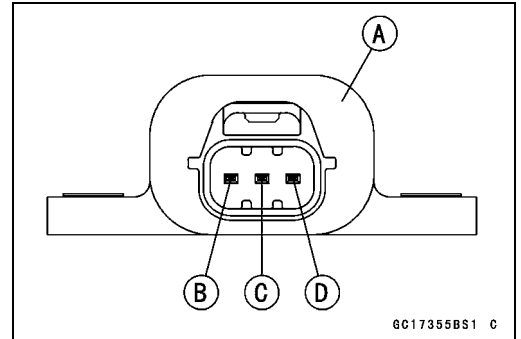
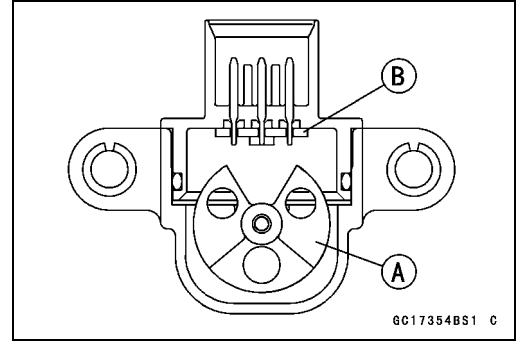

*Removal*

**CAUTION**

**Never drop the down-sensor, especially on a hard surface. Such a shock to the sensor can damage it.**

- Remove:
  - Fuel Tank (see Fuel Tank Removal)
  - Connector [A]
  - Bolts [B]
  - Vehicle-down-sensor [C] and Washers

*Installation*

- The UP mark [A] of the sensor should face upward.

**⚠ WARNING**

**Incorrect installation of the vehicle-down-sensor could cause sudden loss of engine power. The rider could lose balance during certain riding situations, like leaning over in a turn, with the potential for an accident resulting in injury or death. Ensure that the down-sensor is held in place by the sensor brackets.**

*Inspection*

**NOTE**

○ Be sure the battery is fully charged.

- Remove:
  - Fuel Tank (see Fuel Tank Removal)

## 3-70 FUEL SYSTEM (DFI)

### Vehicle-down-sensor (Service Code 31)

- Connect a digital volt meter [A] to the connector of the vehicle-down-sensor [B], with the needle adapter set [C].

#### Vehicle-down-sensor Power Source Voltage Connections to Sensor

Meter (+) → BL lead [D]

Meter (-) → BR/BK lead [E]

- Turn the ignition switch ON, and measure the power source voltage with the connector joined.

#### Power Source Voltage at Sensor

Standard: 4.75 ~ 5.25 V DC

- Turn the ignition switch OFF.
- ★ If there is no voltage, check the following:
  - Battery (see Electrical System chapter)
  - ECU Main Fuse 15 A
- ★ If the power source is normal, check the output voltage.

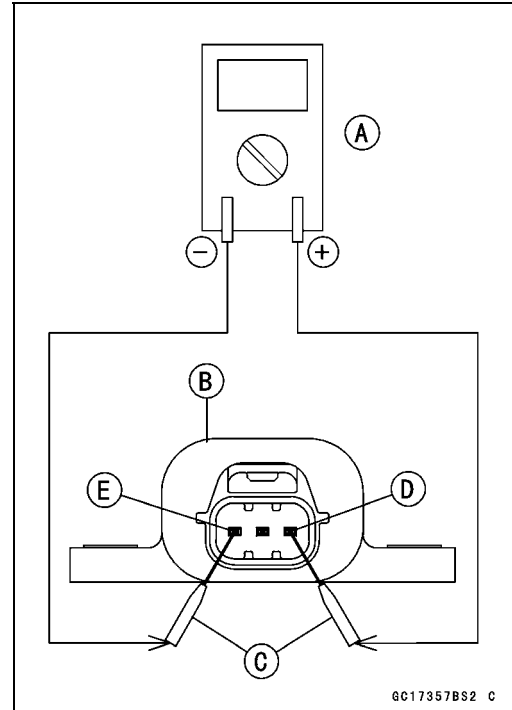

- Turn the ignition switch OFF.
- Remove the sensor.
- Connect a digital volt meter [A] to the connector, with needle adapter set [B].

Special Tool - Needle Adapter Set: 57001-1457

#### Vehicle-down-sensor Output Voltage Connections to Sensor

Meter (+) → Y/G lead [C]

Meter (-) → BR/BK lead [D]

- Hold the sensor vertically.
- Turn the ignition switch ON, and measure the output voltage with the connector joined.
- Tilt the sensor 60 ~ 70° or more [E] right or left, then hold the sensor almost vertical with the arrow mark pointed up, and measure the output voltage.

#### Output Voltage at Sensor

Standard: with sensor arrow mark pointed up:  
3.55 ~ 4.45 V

with sensor tilted 60 ~ 70° or more  
right or left: 0.65 ~ 1.35 V

#### NOTE

- If you need to test again, turn the ignition switch OFF, and then ON.

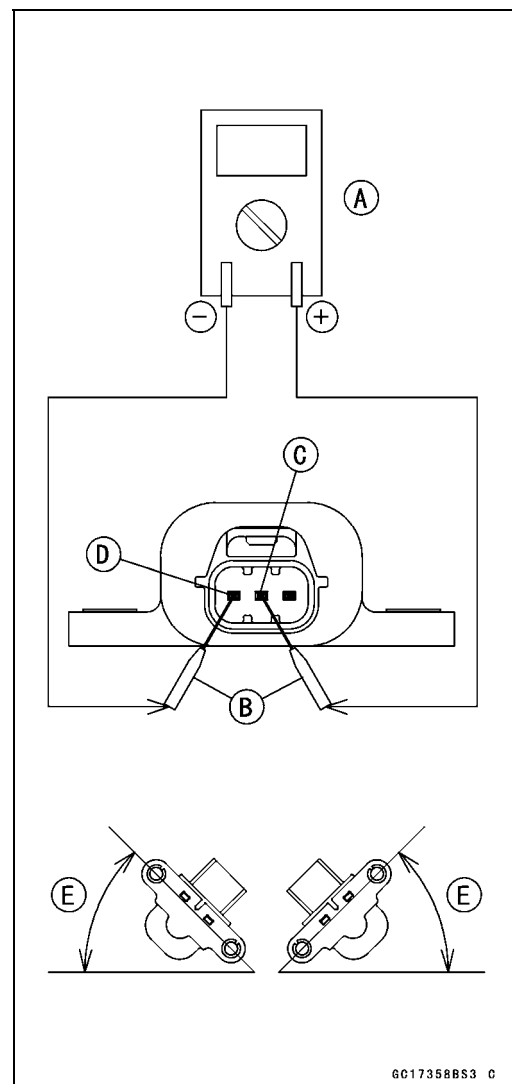



**Vehicle-down-sensor (Service Code 31)**

- Turn the ignition switch OFF.
- Remove the needle adapter set, and apply silicone sealant to the seals of the connector for waterproofing.

**Silicone Sealant (Kawasaki Bond: 56019-120)**

**- Seals of Vehicle-down-sensor Connector**

- ★ If the output voltage is out of the specified, replace the vehicle-down-sensor.

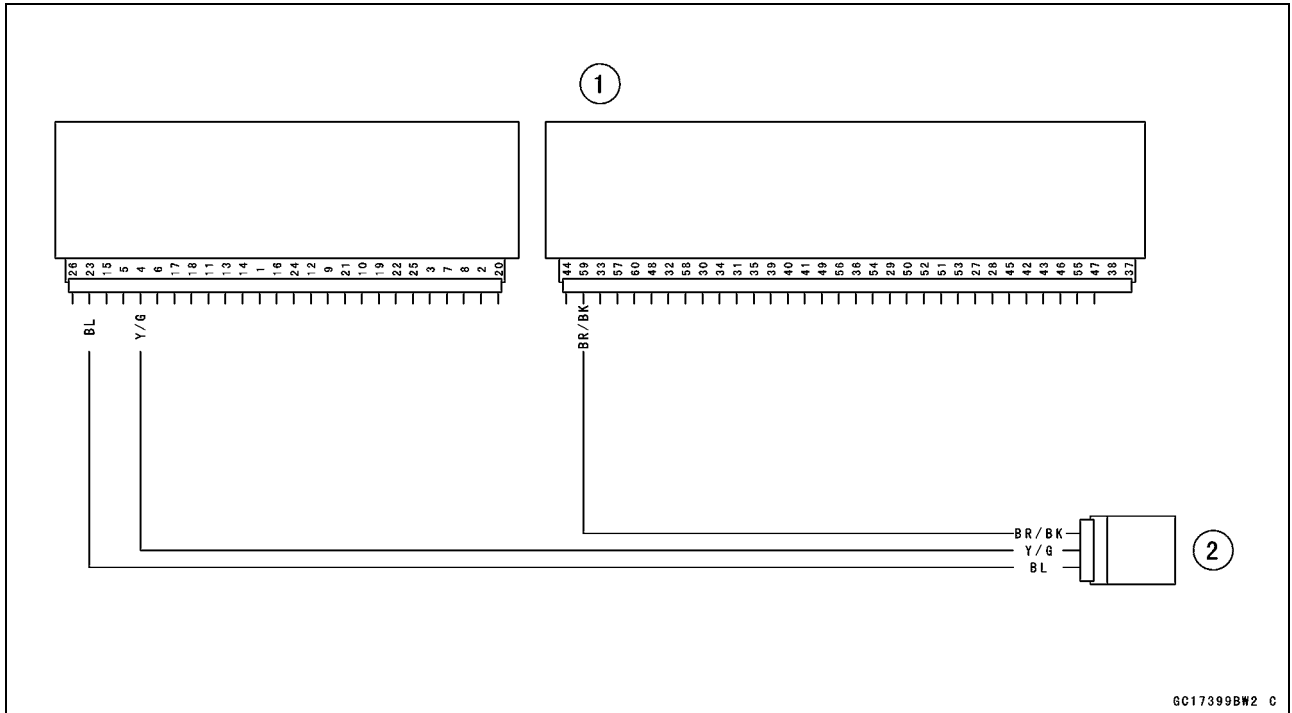

GC17399BW2 C

- 1. ECU
- 2. Vehicle-down-sensor

## 3-72 FUEL SYSTEM (DFI)

### Subthrottle Sensor (Service Code 32)

The subthrottle sensor is a rotating variable resistor that change output voltage according to throttle operating. The ECU senses this voltage change and determines fuel injection quantity, and ignition timing according to engine rpm, and throttle opening.

Input Terminal [A]

Output Terminal [B]

Ground Terminal [C]

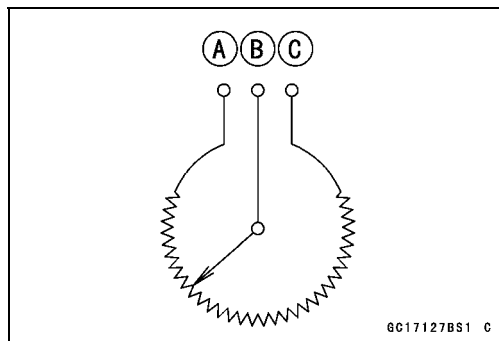

#### Subthrottle Sensor Removal/Adjustment

##### CAUTION

**Do not remove or adjust the subthrottle sensor [A] since it has been adjusted and set with precision at the factory.**

**Never drop the sensor, especially on a hard surface. Such a shock to the sensor can damage it.**

Subthrottle Sensor Connector [B]

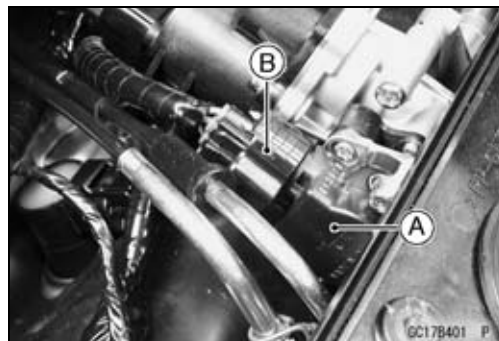

#### Input Voltage Inspection

##### NOTE

○Be sure the battery is fully charged.

- Turn the ignition switch OFF.
- Remove the ECU (see this chapter). Do not disconnect the ECU connectors.
- Connect a digital voltmeter [A] to the connector [B], using the needle adapter set.

**Special Tool - Needle Adapter Set: 57001-1457**

##### Subthrottle Sensor Input Voltage Connections to ECU Connector

Meter (+) → BL lead (terminal 23)

Meter (-) → BR/BK lead (terminal 59)

- Measure the input voltage with the engine stopped, and with the connectors joined.
- Turn the ignition switch ON.

##### Input Voltage at ECU Connector

**Standard: 4.75 ~ 5.25 V DC**

- Turn the ignition switch OFF.
- ★ If the reading of input voltage is less than the standard, check the ECU for its ground, power supply and wiring shorted.
- ★ If the input voltage is within the standard range, check the input voltage at the subthrottle sensor connector.
- Remove the throttle body assembly temporarily (see Throttle Body Assy Removal).

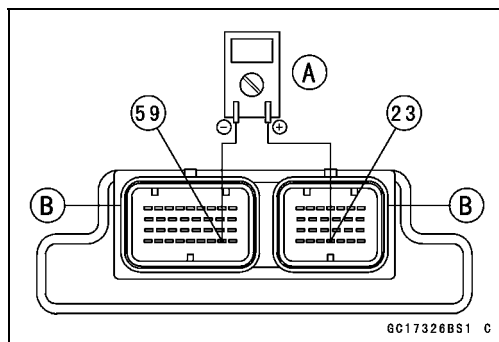

**Subthrottle Sensor (Service Code 32)**

- Disconnect the subthrottle sensor connector [A] and connect the harness adapter [B] between the harness connector and sub throttle sensor connector.
- Connect a digital meter to the harness adapter leads.

**Special Tool - Throttle Sensor Setting Adapter: 57001-1521**

**Subthrottle Sensor Input Voltage Connections to Sensor**

**Meter (+) → BL lead**

**Meter (-) → BR/BK lead**

- Install the throttle body assembly.
- Measure the sensor input voltage with the engine stopped, and with the connector joined.
- Turn the ignition switch ON.

**Input Voltage at Sensor**

**Standard: 4.75 ~ 5.25 V DC**

- Turn the ignition switch OFF.
- ★ If the reading is out of the range, check the wiring (see wiring diagram in this section).
- ★ If the reading is good, check the output voltage of the sensor.

**Output Voltage Inspection**

- Measure the output voltage at the ECU in the same way as input voltage inspection. Note the following.  
Digital Voltmeter [A]  
Connectors [B]

**Special Tool - Needle Adapter Set: 57001-1457**

**Subthrottle Sensor Output Voltage Connections to ECU**

**Meter (+) → BL/W lead (terminal 6)**

**Meter (-) → BR/BK lead (terminal 59)**

- Turn the ignition switch ON.
- Measure the output voltage when the subthrottle valve is fully opened or completely closed by hand.

**Output Voltage at ECU**

**Standard: 0.88 ~ 4.35 V DC (at subthrottle valve full opening to closing)**

**NOTE**

- The throttle sensor is operating correctly if the following voltages are obtained:
  - 0.88 VDC (or slightly higher) with the subthrottle valve at the closed position.
  - 4.35 VDC (or slightly lower) with the subthrottle valve at the fully open position.

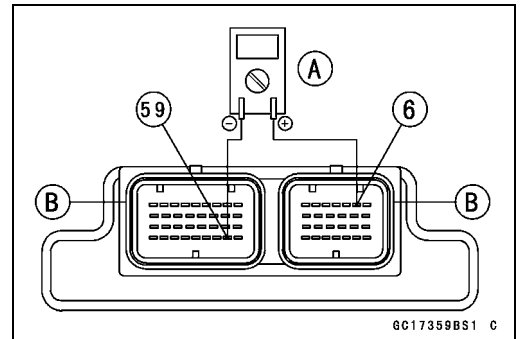
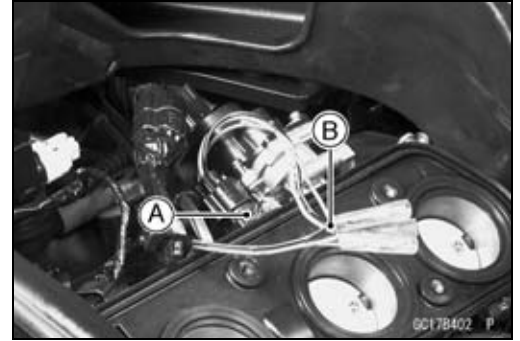

**CAUTION**

**Do not remove or adjust the subthrottle sensor. It has been adjusted and set with precision at the factory.**

**Never drop the sensor can especially on a hard surface. A shock to the sensor can damage it.**

## 3-74 FUEL SYSTEM (DFI)

### Subthrottle Sensor (Service Code 32)

- ★ If the output voltage is within the standard range, check the ECU for a good ground, and power supply (see this chapter). If the ground and power supply are good, replace the ECU.
- ★ If the output voltage is far out of the standard range (e.g. when the wiring is open, the reading is 0 V), check the output voltage again at the sensor connector.
- Disconnect the subthrottle sensor connector [A] and connect the harness adapter [B] between the harness connector and sub throttle sensor connector.
- Connect a digital meter to the harness adapter leads.

**Special Tool - Throttle Sensor Harness Adapter: 57001-1521**

#### Subthrottle Sensor Output Voltage Connections to Sensor

Meter (+) → BL/W lead

Meter (-) → BR/BK lead

- Measure the sensor output voltage with the engine stopped, and with the connector joined.
- Turn the ignition switch ON.
- Measure the output voltage when the subthrottle valve is fully opened or completely closed by hand.

#### Output Voltage at Sensor

**Standard: 0.88 ~ 4.35 V DC (at subthrottle valve full opening to closing)**

#### NOTE

- *The throttle sensor is operating correctly if the following voltages are obtained:*
  - 0.88 VDC (or slightly higher) with the subthrottle valve at the closed position.
  - 4.35 VDC (or slightly lower) with the subthrottle valve at the fully open position.

#### CAUTION

**Do not remove or adjust the subthrottle sensor. It has been adjusted and set with precision at the factory.**

**Never drop the sensor, especially on a hard surface. A shock to the sensor can damage it.**

#### NOTE

- *The standard voltage marked with an asterisk refers to the value when the voltage reading at the Input Voltage Inspection shows 5V exactly.*
- *When the input voltage reading shows other than 5V, derive a voltage range as follows.*

*Example:*

*In the case of a input voltage of 4.75 V.*

*$0.88 \times 4.75 \div 5.00 = 0.84 \text{ V}$*

*$4.35 \times 4.75 \div 5.00 = 4.13 \text{ V}$*

*Thus, the valid range is 0.84 ~ 4.13 V*

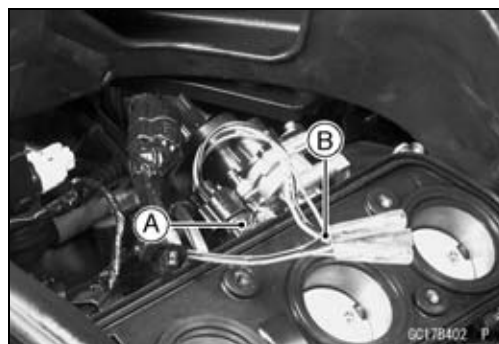

**Subthrottle Sensor (Service Code 32)**

- After subthrottle sensor voltage inspection, remove the harness adapter.
- ★ If the reading is out of the standard range, inspect the throttle sensor resistance.
- ★ If the output voltage is normal, check the wiring for continuity (see next diagram).

**Resistance Inspection**

- Turn the ignition switch OFF.
- Disconnect the subthrottle sensor connector.
- Connect a digital meter [A] to the subthrottle sensor connector [B].
- Measure the subthrottle sensor resistance.

**Subthrottle Sensor Resistance**

**Connections:** BL lead [C] ↔ BR/BK lead [D]

**Standard:** 4 ~ 6 kΩ

- ★ If the reading is out of the range, replace the throttle body assy.
- ★ If the reading is within the range, but the problem still exists, replace the ECU (see this chapter).

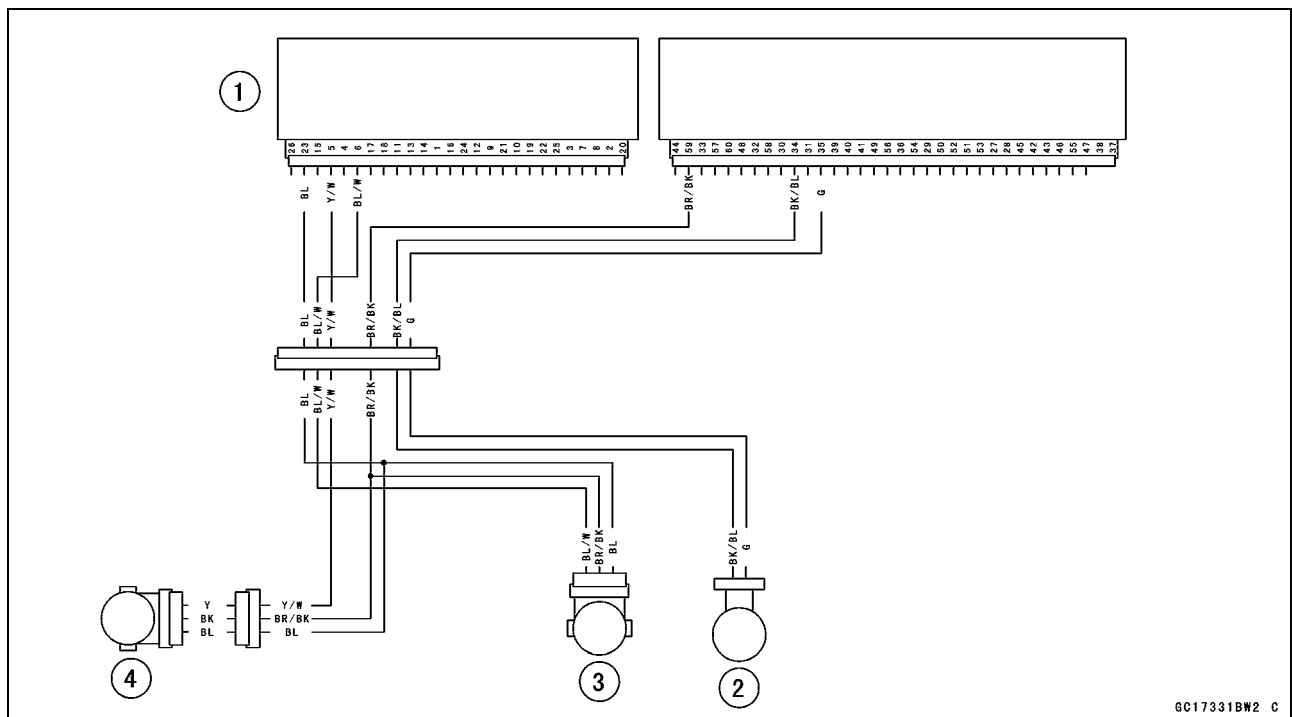
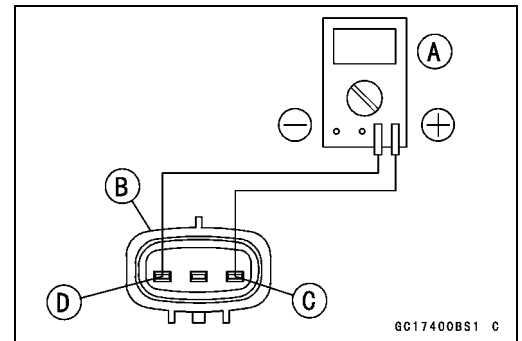

1. ECU
2. Subthrottle Valve Actuator
3. Subthrottle Sensor
4. Main Throttle Sensor

## 3-76 FUEL SYSTEM (DFI)

### Exhaust Butterfly Valve Actuator Sensor (Service Code 34)

#### Exhaust Butterfly Valve Actuator Sensor Inspection

- Turn the ignition switch OFF.
- Disconnect the exhaust butterfly valve actuator sensor connector.
- Connect a digital meter [A] to the exhaust butterfly valve actuator sensor connector [B].
- Measure the exhaust butterfly valve actuator sensor resistance.

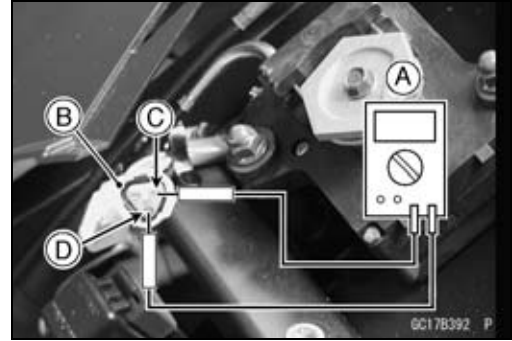

#### Exhaust Butterfly Valve Actuator Sensor Resistance

Connections: W lead [C] ↔ BK lead [D]

Standard: 4 ~ 6 kΩ

- ★ If the reading is out of the range, replace the exhaust butterfly valve actuator sensor.

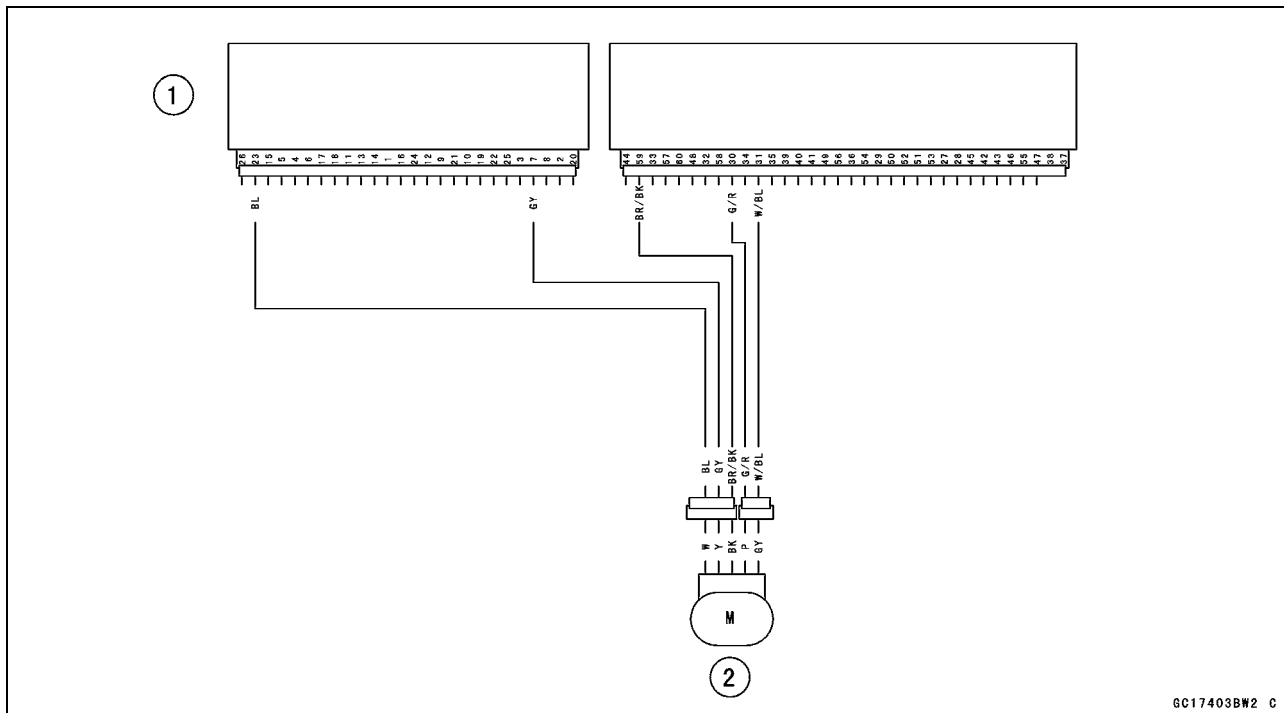

1. ECU

2. Exhaust Butterfly Valve Actuator

**Immobilizer Amplifier (Service Code 35)**

*Antenna Resistance Inspection*

- Remove:
  - Left Lower Fairing (see Frame chapter)
- Disconnect:
  - Antenna Lead Connector [A]
- Measure the resistance of the antenna coil in the ignition switch as follows.

**Antenna Resistance**  
**Connections to Antenna**  
**Meter → Black Lead**  
**Meter → Black Lead**

**Standard:        About 0.6 ~ 0.9 Ω**

★ If the resistance is out of the standard range, replace the ignition switch.

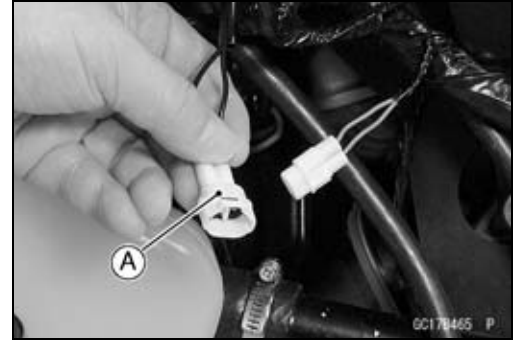

*Amplifier Input Voltage Inspection*

**NOTE**

○ Be sure the battery is fully charged.

- Turn the ignition switch OFF.
  - Remove:
    - Left Lower Fairing (see Frame chapter)
    - Bracket Bolt [A]
    - Connector Bracket [B]
  - Connect a digital voltmeter to the connectors, using the needle adapter set.
- Special Tool - Needle Adapter Set: 57001-1457**

**Amplifier Input Voltage**  
**Connections to Connectors**  
**Meter (+) → BR/W Lead in Meter Lead Connector [A]**  
**Meter (-) → BK Lead in Amplifier Lead Connector [B]**

- Measure the input voltage DC with the connectors joined.
- Turn the ignition switch ON.

**Input Voltage**  
**Standard:        Battery Voltage**

- Turn the ignition Switch OFF.
- ★ If the reading is out of the range, check the wiring (see wiring diagram in next section).
- ★ If the reading and antenna resistance are good, replace the amplifier.

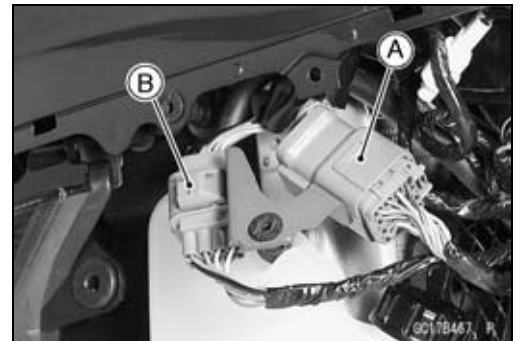
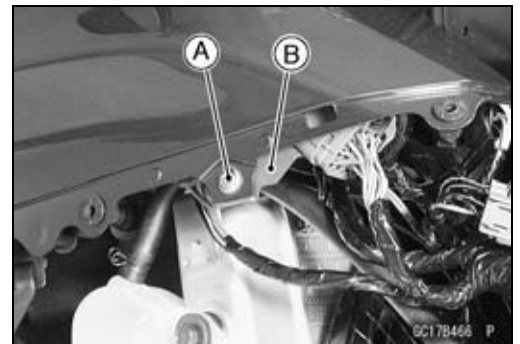

## 3-78 FUEL SYSTEM (DFI)

### Blank Key Detection (Service Code 36)

This code appears in the following conditions.

- The transponder [A] in the master and/or user key is malfunction.
- When the spare key of unregistration is used.
- When the master key is registered in the registered ECU. Therefore, the service code 36 will disappear when the above issue is solved.



#### User Key Inspection

- Register the user key correctly (see Electrical System chapter).
- ★ If the service code 36 appears again, the transponder in the key is malfunction, replace it.

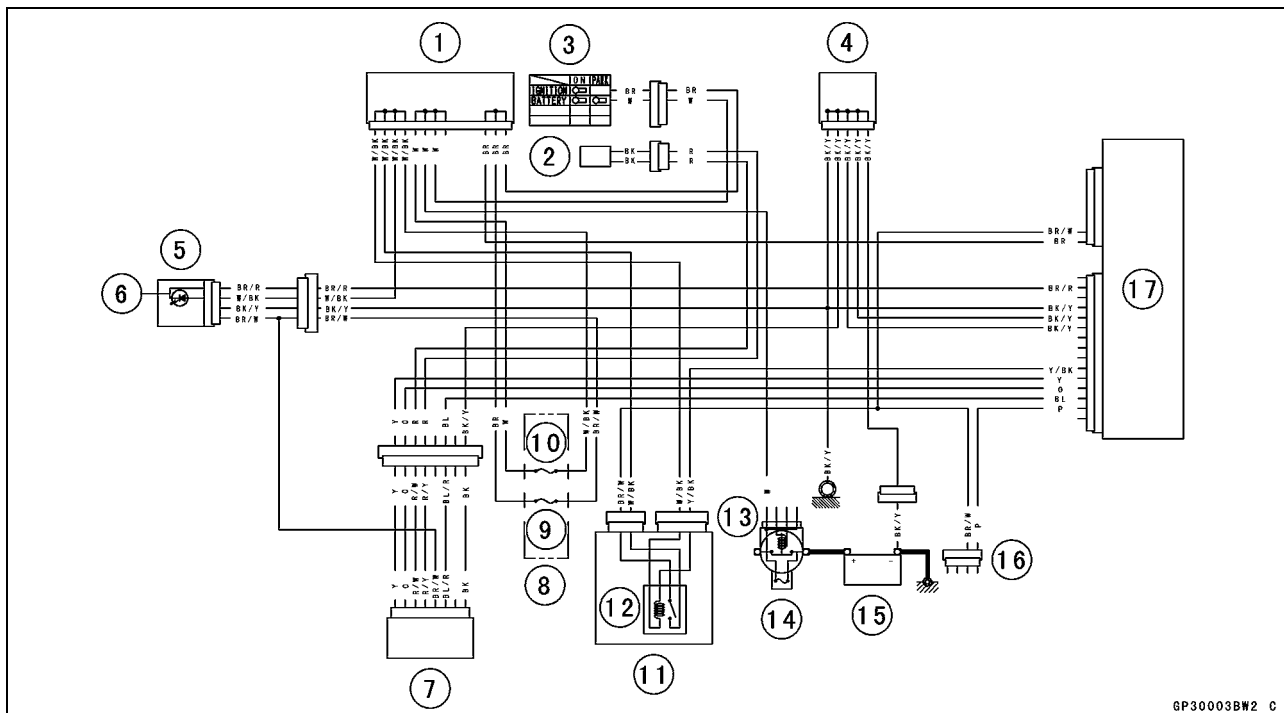

GP30003BW2 C

1. Joint Connector 4
2. Immobilizer Antenna
3. Ignition Switch
4. Joint Connector 2
5. Meter Unit
6. FI Indicator Light (LED)
7. Immobilizer Amplifier
8. Fuse Box
9. Ignition Fuse 10 A
10. ECU Fuse 15 A
11. Relay Box
12. ECU Main Relay
13. Starter Relay
14. Main Fuse 30 A
15. Battery
16. Immobilizer/Kawasaki Diagnostic System Connector
17. ECU



**Fuel Injectors #1, #2, #3, #4: (Service Code 41, 42, 43, 44)**

- Fuel Injector #1: (Service Code 41)
- Fuel Injector #2: (Service Code 42)
- Fuel Injector #3: (Service Code 43)
- Fuel Injector #4: (Service Code 44)

**CAUTION**

**Never drop the injector, especially on a hard surface. Such a shock to the injector can damage it.**

**NOTE**

○Do not remove the injectors from the throttle bodies.

*Power Source Voltage Inspection*

**NOTE**

○Be sure the battery is fully charged.

- Turn the ignition switch OFF.
- Remove the ECU (see ECU Removal). Do not disconnect the ECU connectors.
- Connect a digital voltmeter [A] to the connector [B], with the needle adapter set.
- Measure the power source voltage with the engine stopped, and with the connectors joined.

**Special Tool - Needle Adapter Set: 57001-1457**

- Turn the ignition switch ON.

**Injector Power Source Voltage at ECU Connections to ECU**

- Meter (+) → W/R lead (terminal 21)**
- Meter (-) → Battery (-) Terminal**

**Power Source Voltage at ECU**

**Standard: Battery Voltage for 4 seconds, and then 0 V**

- ★ If the power source voltage is less than the standard, check the fuel pump and ECU main relay (see this chapter), and the ECU for its ground, and power supply (see this chapter). If the relays, ground and power supply are good, replace the ECU.

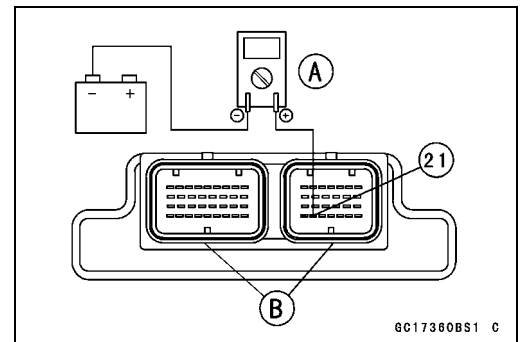

## 3-80 FUEL SYSTEM (DFI)

### Fuel Injectors #1, #2, #3, #4: (Service Code 41, 42, 43, 44)

- ★ If the reading is normal, remove the air cleaner housing, and check the power source voltage at the injector connector [B], with a digital volt meter [A].
- Measure the power source voltage with the engine stopped, and the connector joined, with a digital meter and needle adapter set [C].
- Turn the ignition switch ON.
  - Injector #1 BL/R Lead
  - Injector #2 BL/G Lead
  - Injector #3 BL/BK Lead
  - Injector #4 BL/Y Lead
  - Injector Power Supply W/R Lead

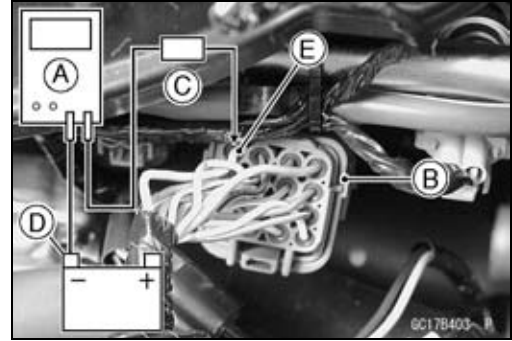

#### Injector Power Source Voltage at Injector Connections to Injector #1, #2, #3, #4

Meter (+) → W/R lead [E]

Meter (-) → Battery (-) Terminal [D]

#### Power Source Voltage at Injector Connector

Standard: Battery Voltage for 4 seconds, and then 0 V

- Turn the ignition switch OFF.
- ★ If the reading is out of the standard, check the wiring (see wiring diagram in this section).
- ★ If the reading is good, and the power source voltage is normal, check the output voltage.

#### Output Voltage Inspection

- Measure the output voltage at the ECU connector in the same way as power source voltage inspection. Note the following.
- Turn the ignition switch ON.

#### Injector Output Voltage at ECU

##### Connections for Injector #1

Meter (+) → BL/R lead (terminal 29)

Meter (-) → Battery (-) Terminal

##### Connections for Injector #2

Meter (+) → BL/G lead (terminal 36)

Meter (-) → Battery (-) Terminal

##### Connections for Injector #3

Meter (+) → BL/BK lead (terminal 54)

Meter (-) → Battery (-) Terminal

##### Connections for Injector #4

Meter (+) → BL/Y lead (terminal 56)

Meter (-) → Battery (-) Terminal

#### Output Voltage at ECU

Standard: Battery Voltage for 4 seconds, and then 0 V

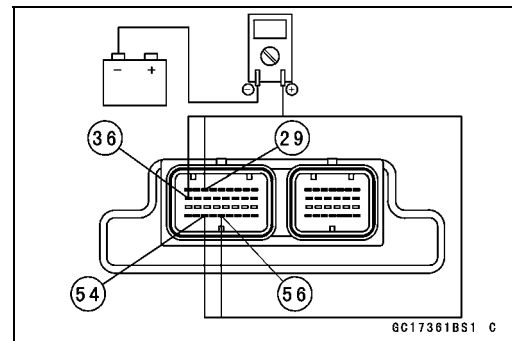

**Fuel Injectors #1, #2, #3, #4: (Service Code 41, 42, 43, 44)**

- ★ If the output voltage is normal, check the ECU for its ground, and power supply (see this chapter). If the ground and power supply are good, replace the ECU.
- ★ If the output voltage is out of the standard, remove the air cleaner housing, and check the output voltage at the injector connector [B] using a digital meter [A] and needle adapter set [C] (when the lead is open, the output voltage is 0 V).
- Turn the ignition switch ON.

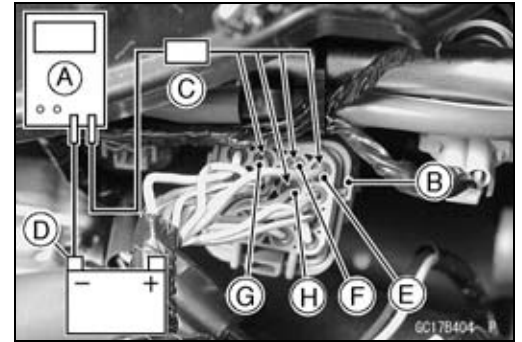

**Injector Output Voltage at Injector**

**Connections to Injector #1**

- Meter (+) → BL/R lead [E]
- Meter (-) → Battery (-) Terminal [D]

**Connections to Injector #2**

- Meter (+) → BL/G lead [F]
- Meter (-) → Battery (-) Terminal [D]

**Connections to Injector #3**

- Meter (+) → BL/BK lead [G]
- Meter (-) → Battery (-) Terminal [D]

**Connections to Injector #4**

- Meter (+) → BL/Y lead [H]
- Meter (-) → Battery (-) Terminal [D]

**Output Voltage at Injector Connector**

**Standard: Battery Voltage**

- ★ If the output voltage is normal, check the wiring for continuity (see next diagram). If the wiring is good, perform “Audible Inspection” for confirmation.
- ★ If the output voltage is out of the standard, perform “Audible Inspection” for confirmation.

## 3-82 FUEL SYSTEM (DFI)

### Fuel Injectors #1, #2, #3, #4: (Service Code 41, 42, 43, 44)

#### Audible Inspection

- Remove:
  - Air Cleaner Housing (see Air Cleaner Housing Removal)
- Connect the following parts temporary.
  - Fuel Pump Connector
  - Extension Tube

**Special Tool - Extension Tube: 57001-1578**

- Start the engine.
- Apply the tip of a screwdriver to the injector. Put the grip end onto your ear, and listen whether the injector is clicking or not.
- A sound scope can also be used.
- Do the same for the other injector.
- ★ If all the injectors click at a regular intervals, the injectors are good.
- The click interval becomes shorter as the engine speed rises.
- ★ If either injector doesn't click, perform the "Injector Signal Test" for injector operation.

#### Injector Signal Test

- Prepare two test light sets with male terminals as shown.
  - Rating of Bulb [A]: 12 V × 3 ~ 3.4 W
  - Terminal Width [B]: 1.8 mm (0.07 in.)
  - Terminal Thickness [C]: 0.8 mm (0.03 in.)

#### CAUTION

**Do not use larger terminals than specified above. A larger terminal could damage the injector main harness connector (female), leading to harness repair or replacement.**

**Be sure to connect bulbs in series. The bulb works as a current limiter to protect the solenoid in the injector from excessive current.**

- Remove connectors for injector [A].
- Connect each test light set [B] to the injector sub harness connector [C].
- Turn the ignition switch ON.
- While cranking the engine with the starter motor, watch the test lights.
- ★ If the test lights flicker at regular intervals, the injector circuit in the ECU, and the wiring are good. Perform the "Injector Resistance Inspection".

- Injector signals can be also confirmed by connecting the hand tester (× 10 V AC) instead of the test light set to the injector main harness (female) connector. Crank the engine with the starter motor, and check to see if the hand oscillates at regular intervals.

**Special Tool - Hand Tester: 57001-1394**

- ★ If the test light doesn't flicker (or the test hand doesn't oscillates), check the wiring and connectors again. If the wiring is good, replace the ECU.

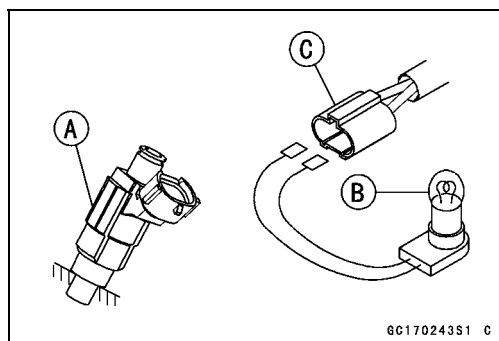
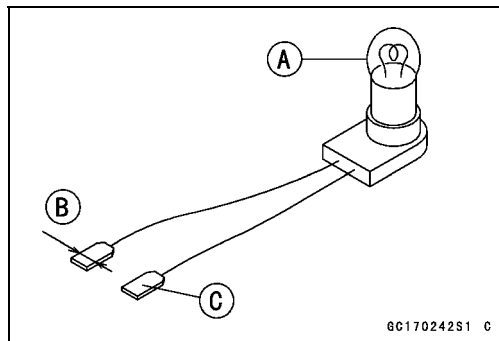
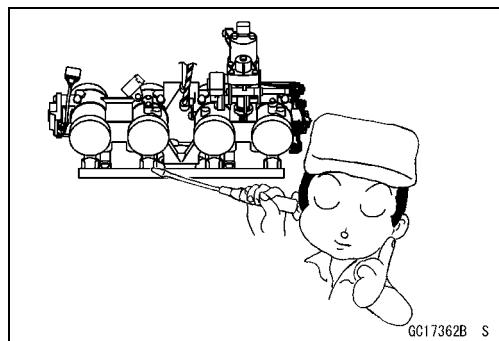

**Fuel Injectors #1, #2, #3, #4: (Service Code 41, 42, 43, 44)**

*Injector Resistance Inspection*

- Remove the throttle body assy (see Throttle Body Assy Removal).
- Disconnect the connector from the injector [A] (see Throttle Body Disassembly/Assembly).
- Measure the injector resistance with the hand tester.



**Injector Resistance**

**Connections to Injector**

Meter (+)	↔	Meter (-)
#1: W/R	↔	BL/R Terminal
#2: W/R	↔	BL/G Terminal
#3: W/R	↔	BL/BK Terminal
#4: W/R	↔	BL/Y Terminal

**Standard:        about 11.7 ~ 12.3 Ω @20°C (68°F)**

- ★ If the reading is out of the range, perform the “Injector Unit Test”.
- ★ If the reading is normal, perform the “Injector Unit Test” for confirmation.

*Injector Unit Test*

- Use two leads [A] and the same test light set [B] as in “Injector Signal Test”.  
 Rating of Bulb [C]: 12 V × (3 ~ 3.4) W  
 12 V MF Battery [D]

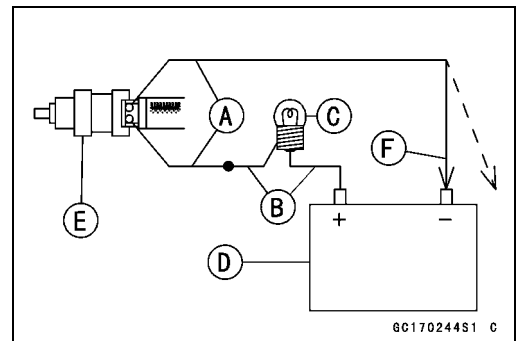

<b>CAUTION</b>
<b>Be sure to connect the bulb in series. The bulb works as a current limiter to protect the solenoid in the injector from excessive current.</b>

- Connect the test light set to the injector [E] as shown.
- Open and connect [F] the end of the lead to the battery (-) terminal repeatedly. The injector should click.
- ★ If the injector does not click, replace the throttle body assy.
- ★ If the injector clicks, check the wiring again. If the wiring is good, replace the ECU.

## 3-84 FUEL SYSTEM (DFI)

### Fuel Injectors #1, #2, #3, #4: (Service Code 41, 42, 43, 44)

#### Injector Fuel Line Inspection

- Remove the throttle body assy (see this chapter).
- Check the injector fuel line for leakage as follows:
  - Connect a commercially available vacuum/pressure pump [A] to the nipple of the delivery pipe [B] with the fuel hose [C] (both ends connected with the clamps [D]) as shown.
  - Apply soap and water solution to the areas [E] as shown.
  - Watching the pressure gauge, squeeze the pump lever [F], and build up the pressure until the pressure reaches the maximum pressure.

#### Fuel Line Maximum Pressure

Standard: 300 kPa (3.06 kgf/cm<sup>2</sup>, 43 psi)

#### CAUTION

During pressure testing, do not exceed the maximum pressure for which the system is designed.

- Watch the gauge for at least 6 seconds.
- ★ If the pressure holds steady, the system is good.
- ★ If the pressure drops at once, or if bubbles are found in the area, the line is leaking. Replace the delivery pipe, injectors and related parts.
- Repeat the leak test, and check the fuel line for no leakage.
- Install the throttle body assy (see this chapter).
- Run the hoses correctly (see Cable, Wire, and Hose Routing section in Appendix chapter).

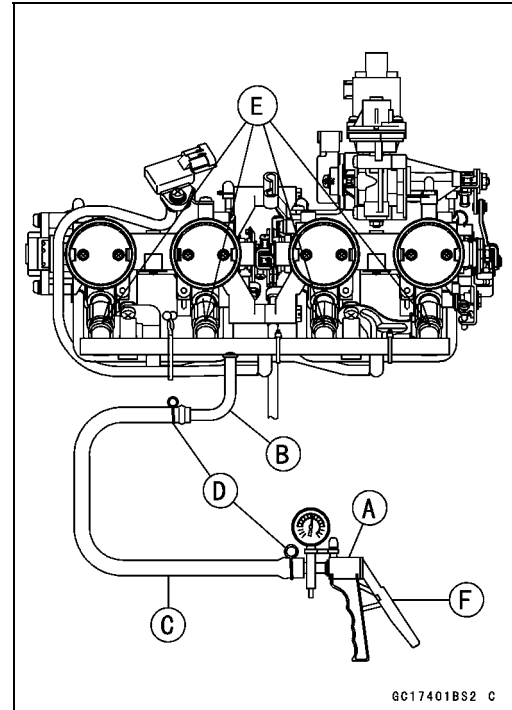

Fuel Injectors #1, #2, #3, #4: (Service Code 41, 42, 43, 44)

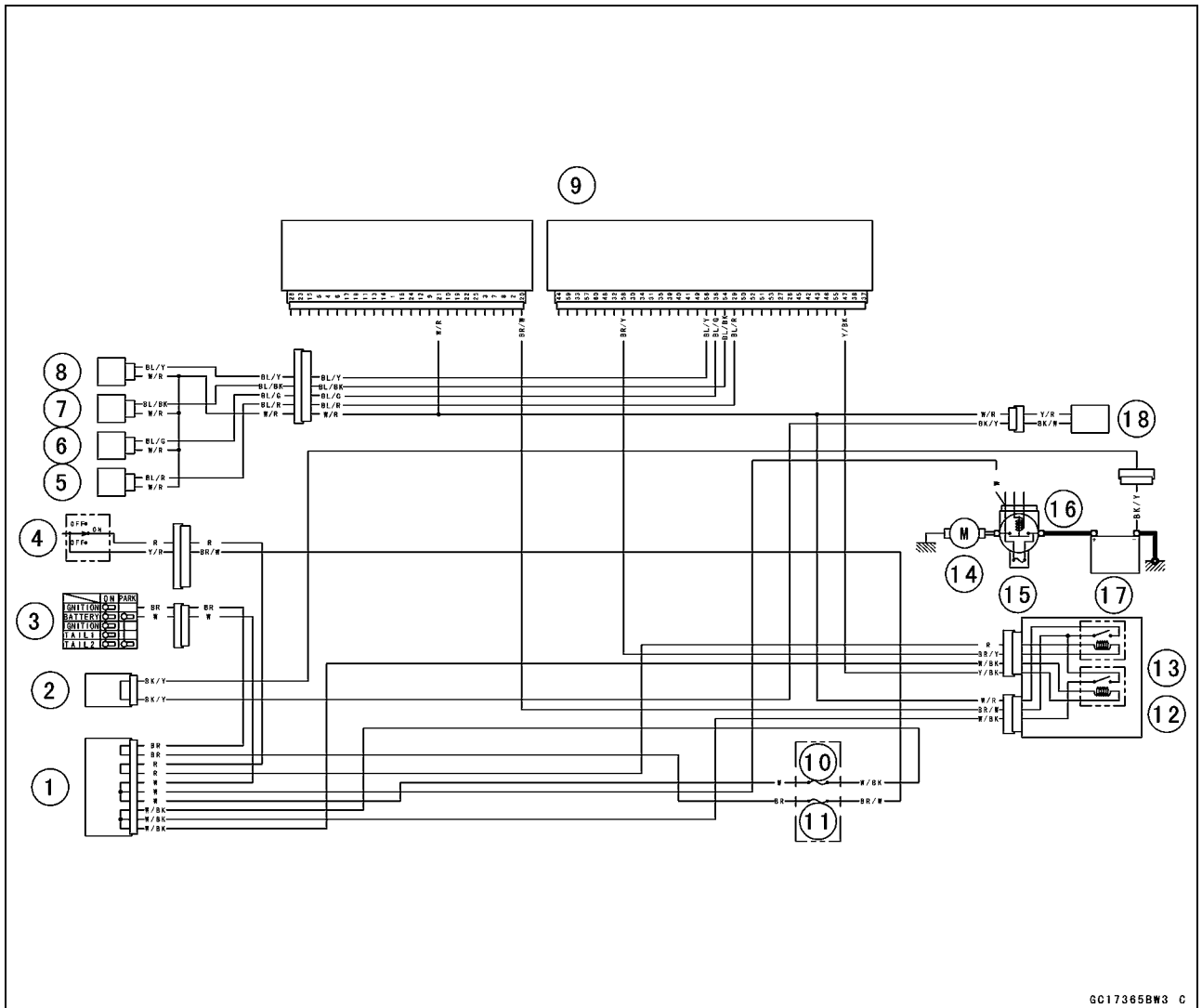

GC17365BW3 C

1. Joint Connector 4
2. Joint Connector 2
3. Ignition Switch
4. Engine Stop Switch
5. Fuel Injector #1
6. Fuel Injector #2
7. Fuel Injector #3
8. Fuel Injector #4
9. ECU
10. ECU Fuse 15 A
11. Ignition Fuse 10 A
12. ECU Main Relay
13. Fuel Pump Relay
14. Starter Motor
15. Main Fuse 30 A
16. Starter Relay
17. Battery
18. Fuel Pump

## 3-86 FUEL SYSTEM (DFI)

### Fuel Pump Relay (Service Code 45, 46)

Service code 45 is open to the fuel pump relay system.  
Service code 46 is stuck ON to the fuel pump relay system.

#### Fuel Pump Relay Removal

##### CAUTION

**Never drop the relay, especially on a hard surface.  
Such a shock to the relay can damage it.**

- The fuel pump relay is included in the relay box.
- Remove:
  - Seats (see Frame chapter)
- Remove the relay box [A] from the bracket and disconnect the connector.

#### Fuel Pump Relay Inspection

- Remove the relay box (see above).
- Connect the hand tester [A] and one 12 V battery to the relay connector as shown.

##### Special Tool - Hand Tester: 57001-1394

Relay Coil Terminals [1] and [2]

Relay Switch Terminals [3] and [4]

##### Testing Relay

Tester range: 1  $\Omega$  range

Criteria: When battery is connected  $\rightarrow 0 \Omega$

When battery is disconnected  $\rightarrow \infty \Omega$

- ★ If the relay does not work as specified, replace the relay box.

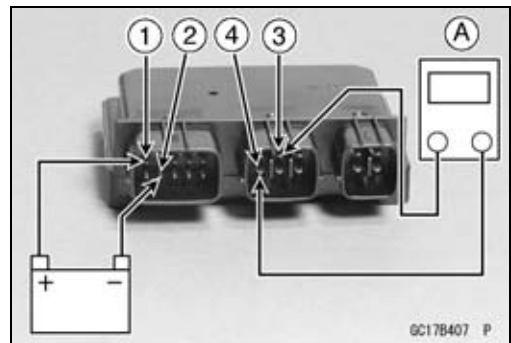
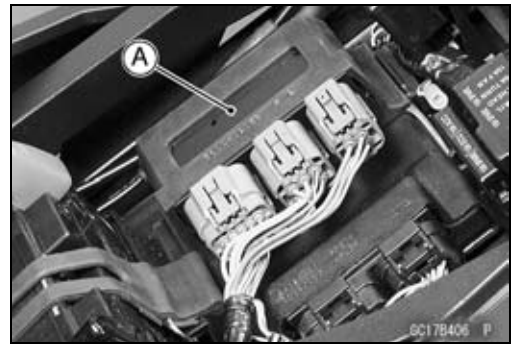



Fuel Pump Relay (Service Code 45, 46)

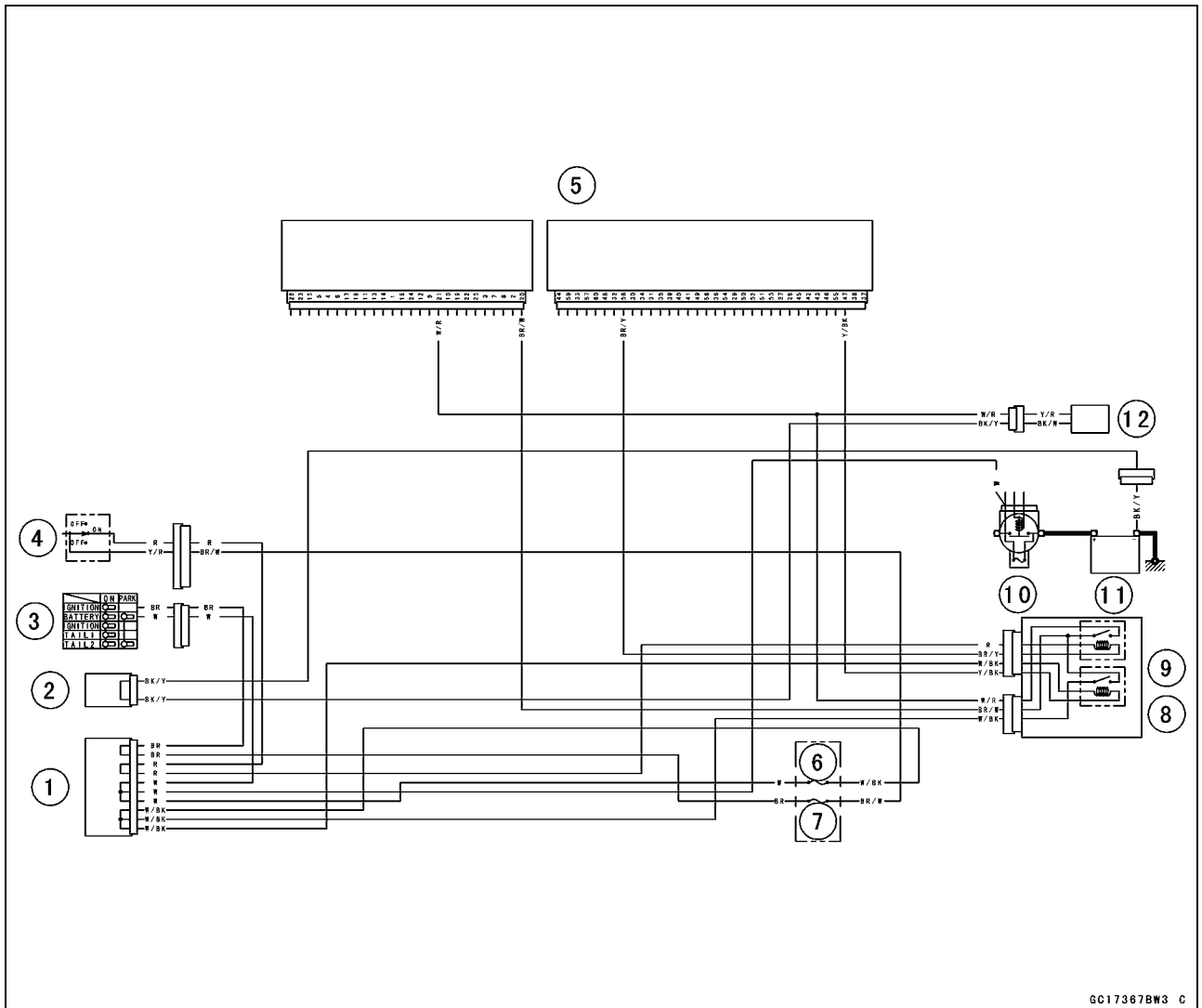

GC17367BW3 C

1. Joint Connector 4
2. Joint Connector 2
3. Ignition Switch
4. Engine Stop Switch
5. ECU
6. ECU Fuse 15 A
7. Ignition Fuse 10 A
8. ECU Main Relay
9. Fuel Pump Relay
10. Starter Motor
11. Main Fuse 30 A
12. Starter Relay
13. Battery
14. Fuel Pump

## 3-88 FUEL SYSTEM (DFI)

### Stick Coils #1, #2, #3, #4: (Service Code 51, 52, 53, 54)

- Stick Coil #1: Ignition Coil (Service Code 51)
- Stick Coil #2: Ignition Coil (Service Code 52)
- Stick Coil #3: Ignition Coil (Service Code 53)
- Stick Coil #4: Ignition Coil (Service Code 54)

#### Removal/Installation

#### CAUTION

**Never drop the ignition coils, especially on a hard surface. Such a shock to the ignition coil can damage it.**

- See the Ignition System section in the Electrical System chapter.

#### Input Voltage Inspection

#### NOTE

○ Be sure the battery is fully charged.

- Turn the ignition switch OFF.
- Remove the ECU (see this chapter). Do not disconnect the ECU connector.
- Connect a digital voltmeter [A] as shown, with the needle adapter set.
- Measure the input voltage to each primary winding of the ignition coils with the engine stopped, and with the connectors joined.
- Turn the ignition switch ON.

#### Stick Coil Input Voltage at ECU

##### Connections for Stick Coil #1

Meter (+) → BK lead (terminal 28)

Meter (-) → BK/Y lead (terminal 51)

##### Connections for Stick Coil #2

Meter (+) → BK/G lead (terminal 53)

Meter (-) → BK/Y lead (terminal 51)

##### Connections for Stick Coil #3

Meter (+) → BK/W lead (terminal 52)

Meter (-) → BK/Y lead (terminal 51)

##### Connections for Stick Coil #4

Meter (+) → BK/O lead (terminal 27)

Meter (-) → BK/Y lead (terminal 51)

#### Input Voltage at ECU

Standard:            Battery Voltage

- ★ If the reading is out of the standard, check the wiring (see next wiring diagram).
- ★ If the reading is good, the input voltage is normal. Crank the engine, and check the peak voltage of the stick coils (see Electrical System chapter) in order to check the primary coils.

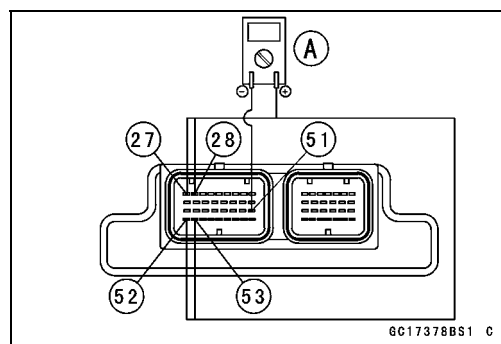

Stick Coils #1, #2, #3, #4: (Service Code 51, 52, 53, 54)

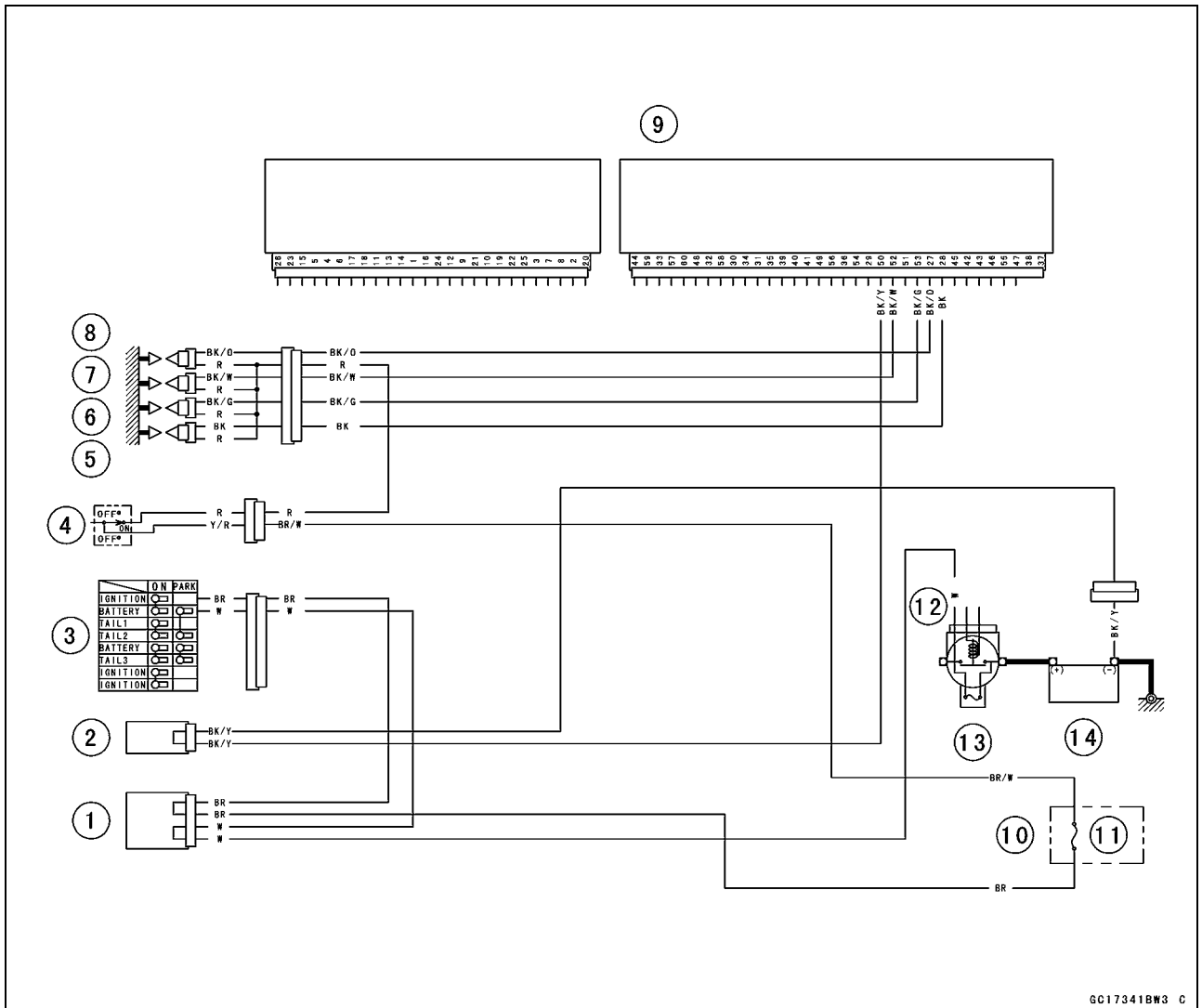

GC17341BW3 C

1. Joint Connector 4
2. Joint Connector 2
3. Ignition Switch
4. Engine Stop Switch
5. Stick Coil #1
6. Stick Coil #2
7. Stick Coil #3
8. Stick Coil #4
9. ECU
10. Fuse Box
11. Ignition Fuse 10 A
12. Starter Relay
13. Main Fuse 30 A
14. Battery

## 3-90 FUEL SYSTEM (DFI)

### Subthrottle Valve Actuator (Service Code 62)

#### Subthrottle Valve Actuator Removal

#### CAUTION

Do not remove the subthrottle valve actuator [A] since it has been adjusted and set with precision at the factory.

Never drop the actuator, especially on a hard surface. Such a shock to the actuator can damage it.

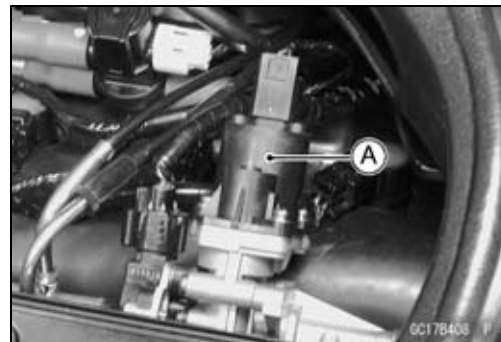

#### Subthrottle Valve Actuator Inspection

- Remove the air cleaner housing (see Air Cleaner Housing Removal).
- Turn the ignition switch ON.
- Check to see that all subthrottle valves [A] open and close smoothly.
- ★ If the subthrottle valves do not operate, check the actuator internal resistance (see Resistance Inspection).

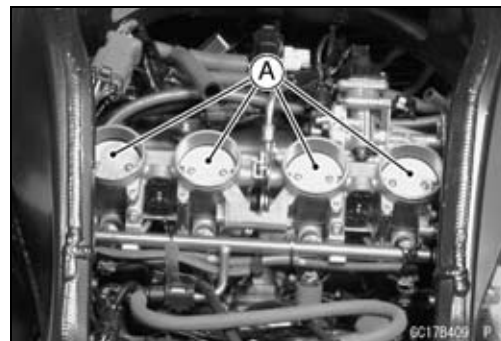

#### Resistance Inspection

- Turn the ignition switch OFF.
- Remove the ECU (see ECU Removal). Do not disconnect the ECU connectors.
- Connect a digital meter [A] to the connector [B], using the needle adapter set.

**Special Tool - Needle Adapter Set: 57001-1457**

- Measure the subthrottle valve actuator resistance.

#### Subthrottle Valve Actuator Resistance

**Connections: BK/BL lead (34) ↔ G lead (35)**

**Standard: Any Reading Resistance (reference 5 ~ 30 Ω)**

- ★ If the reading is 0 or infinity ( $\infty$ ) Ω, replace the throttle body assy.

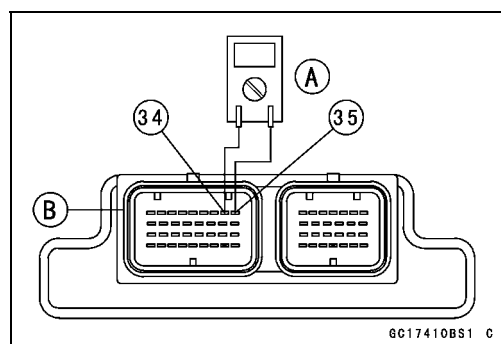

Subthrottle Valve Actuator (Service Code 62)

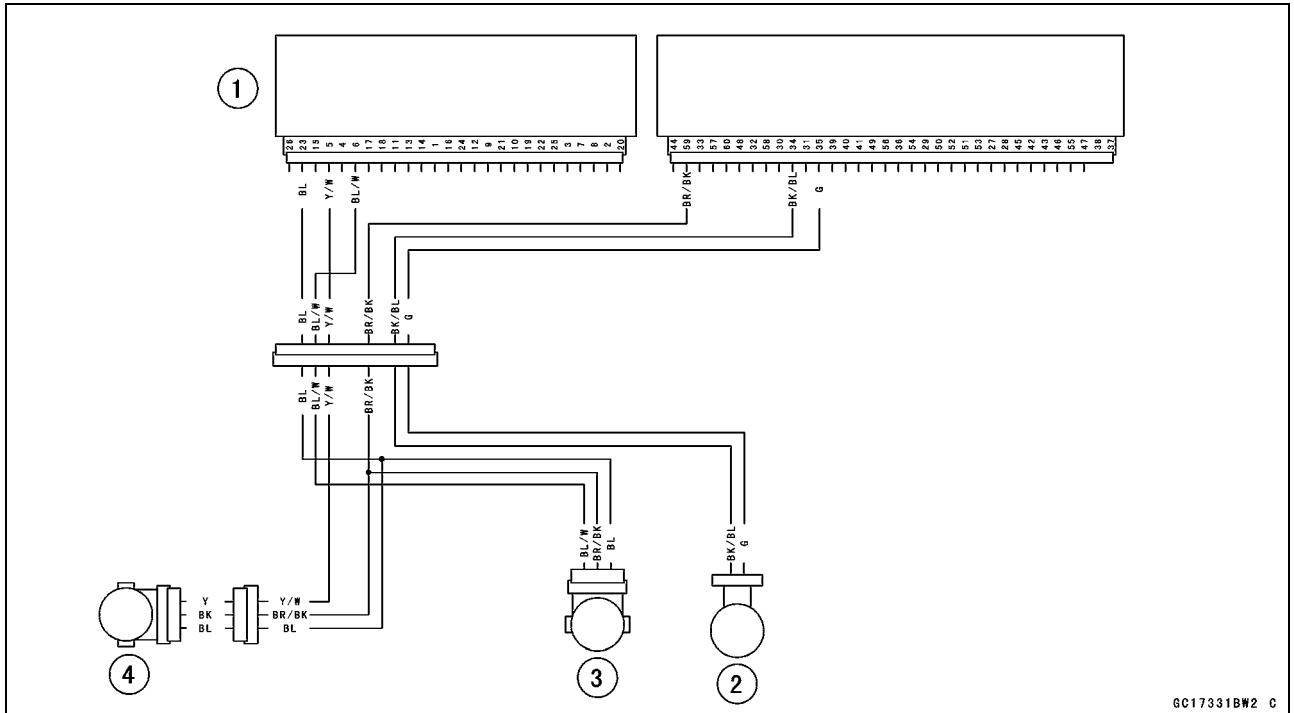

6C17331BW2 C

1. ECU
2. Subthrottle Valve Actuator
3. Subthrottle Sensor
4. Main Throttle Sensor

## 3-92 FUEL SYSTEM (DFI)

### Exhaust Butterfly Valve Actuator (Service Code 63)

#### Exhaust Butterfly Valve Actuator Removal

- Remove:
  - Seats (see Frame chapter)
- Put off the rubber boots [A].
- Loosen the locknuts [A] and adjuster nut [B].
- Remove:
  - Wire Stopper [C]
  - Exhaust Butterfly Valve Cables [D]
  - Connectors [E]
- Remove the nuts [A] and exhaust butterfly valve actuator [B].

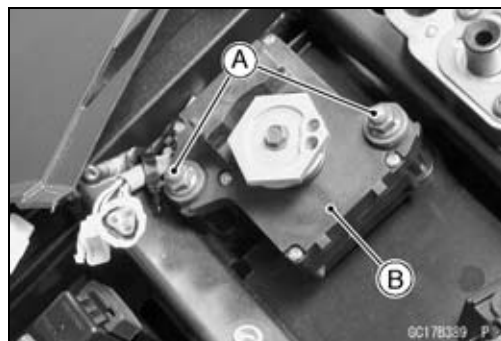
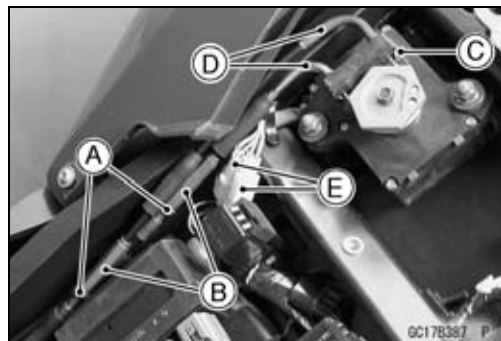
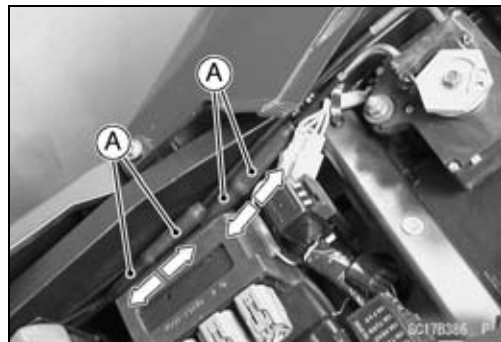

- Remove:
  - Exhaust Butterfly Valve Actuator Pulley [A].
- Hold the pulley with a suitable tool.

#### CAUTION

If the pulley bolt is removed without holding, the actuator damage will occur.

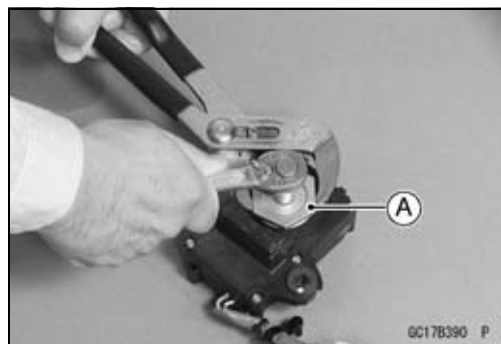

#### Exhaust Butterfly Valve Actuator Installation

- Install the pulley [A] on the actuator.
  - Hold the pulley with a suitable tool [B] and tighten the bolt.
- Torque - Exhaust Butterfly Valve Actuator Pulley Bolt: 4.9 N·m (0.50 kgf·m, 43 in·lb)

#### CAUTION

If the pulley bolt is tightened without holding, the actuator damage will occur.

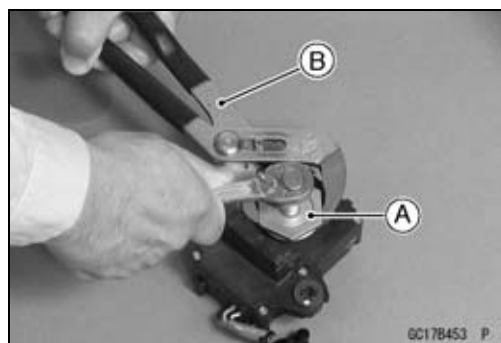

**Exhaust Butterfly Valve Actuator (Service Code 63)**

- Confirm the pulley angle [A] ( $41.7^{\circ} \pm 7^{\circ}$ ) as shown. It is original position of the pulley [B].
- ★ If the angle is not within the specified angle, adjust the actuator as follows.
  - Connect the actuator connectors.
  - Turn the ignition switch ON.
  - Confirm the pulley turns clockwise and then counterclockwise, and clockwise again
  - Turn the ignition switch OFF.
  - Confirm the pulley turns counterclockwise little.
  - The position is original position of the pulley.
- ★ If the position is not within the specified angle above, replace the exhaust butterfly valve actuator.

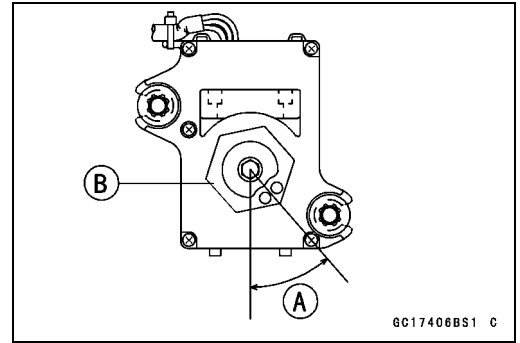

- Install the actuator [A] on the Frame.
  - Collars [B]
  - Washers [C]
  - Exhaust Butterfly Valve Actuator Mounting Nuts [D]
- Tighten:
  - **Torque - Exhaust Butterfly Valve Actuator Mounting Nuts:**  
**7.0 N·m (0.70 kgf·m, 62 in·lb)**
- Install the close cable first and then open cable (see Engine Top End chapter)

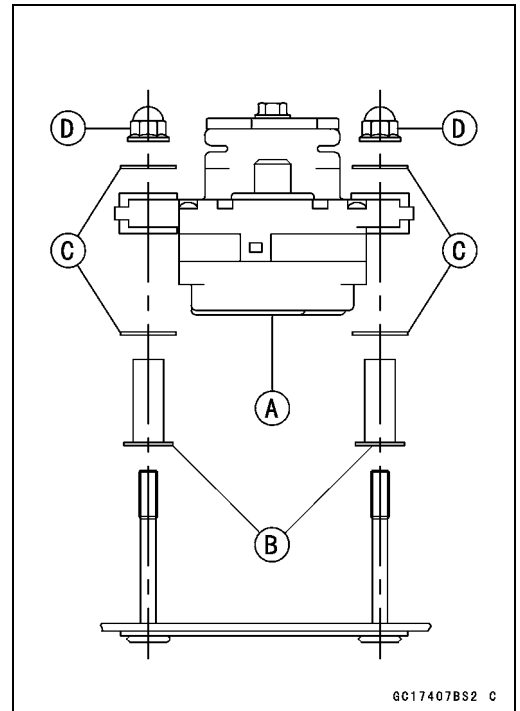

**Exhaust Butterfly Valve Actuator Inspection**

- Remove:
  - Seats (see Frame chapter)
- Turn the ignition switch ON.
- Check to see the pulley [A] clockwise [B] and counterclockwise [C] smoothly.
- ★ If the pulley does not operate, check the exhaust butterfly valve actuator sensor output voltage (see Output Voltage Inspection).

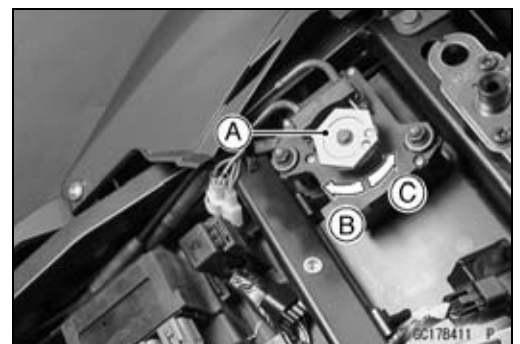

## 3-94 FUEL SYSTEM (DFI)

### Exhaust Butterfly Valve Actuator (Service Code 63)

#### Output Voltage Inspection

- Remove:
  - Seats (see Frame chapter)
- Measure the output voltage at the 3 pins connector of the exhaust butterfly valve actuator [A] when the pulley is original position as follows.
- Disconnect:
  - 2 pins Connector [B]
  - 3 pins Connector [C]
- Connect the adapter [D] between the 3 pins connectors and digital voltmeter [E].
  - Main Harness [F]

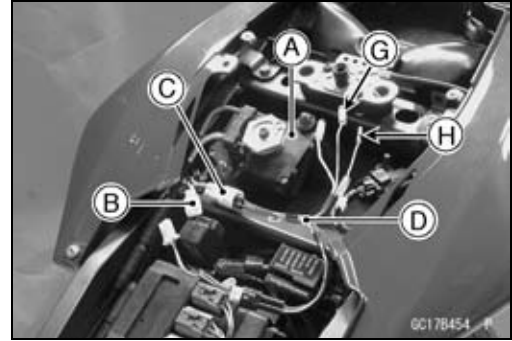

**Special Tool - Throttle Sensor Setting Adapter #1: 57001-1400**

#### Connections

**Meter (+) → Blue Lead [G] in Adapter (Yellow Lead of Actuator)**

**Meter (-) → Black/Blue Lead [H] in Adapter (Black Lead of Actuator)**

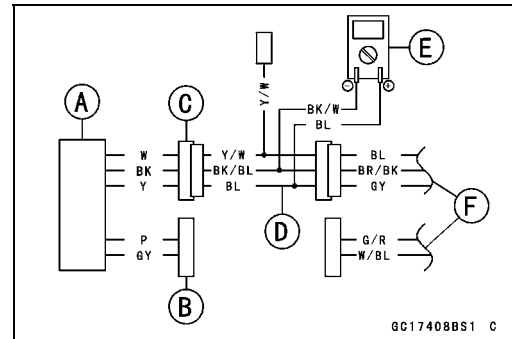

- Turn the ignition switch ON and wait until the pulley stops.
- Turn the ignition switch OFF and wait until the pulley stops. It is original position of the pulley.

#### Actuator Output Voltage (Pulley Original Position)

**Standard: 3.46 ~ 3.76 V**

- ★ If the output voltage is out of the standard, remove the actuator and check the original position unit (see Exhaust Butterfly Valve Actuator Installation).

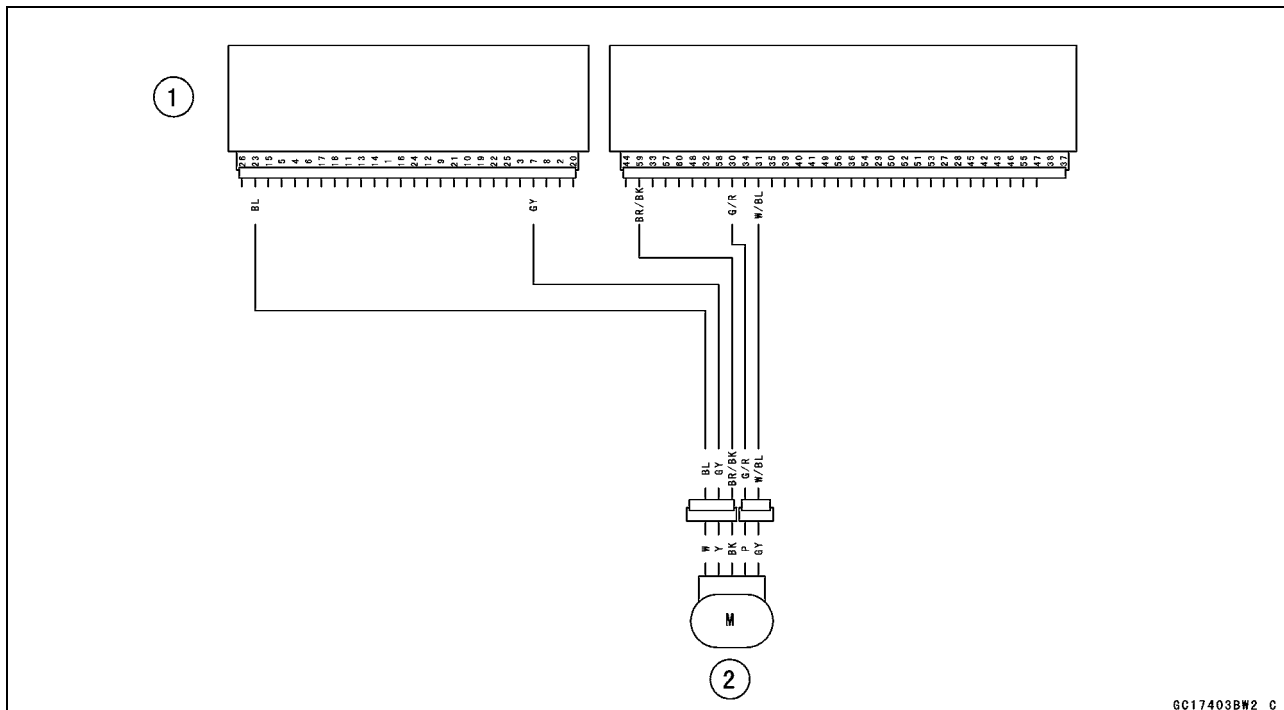

1. ECU
2. Exhaust Butterfly Valve Actuator



**ECU Main Relay (Service Code 75)**

*ECU Main Relay Removal*

<b>CAUTION</b>
<b>Never drop the relay box, especially on a hard surface. Such a shock to the relay can damage it.</b>

- The ECU main relay is included in the relay box.
- Remove:
  - Seats (see Frame chapter)
- Remove the relay box [A] from the bracket and disconnect the connector.

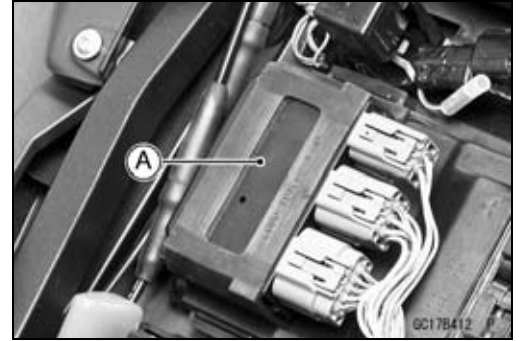

*ECU Main Relay Inspection*

- Remove the relay box (see above).
- Connect the hand tester and one 12 V battery to the relay connector as shown.

**Special Tool - Hand Tester: 57001-1394**

- Relay Coil Terminals [1] and [2]
- Relay Switch Terminals [3] and [4]

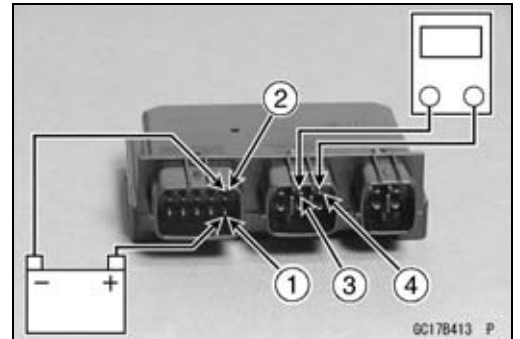

**Testing Relay**

- Tester range:** 1 Ω range
- Criteria:**
  - When battery is connected → 0 Ω
  - When battery is disconnected → ∞ Ω

★ If the relay does not work as specified, replace the relay box.

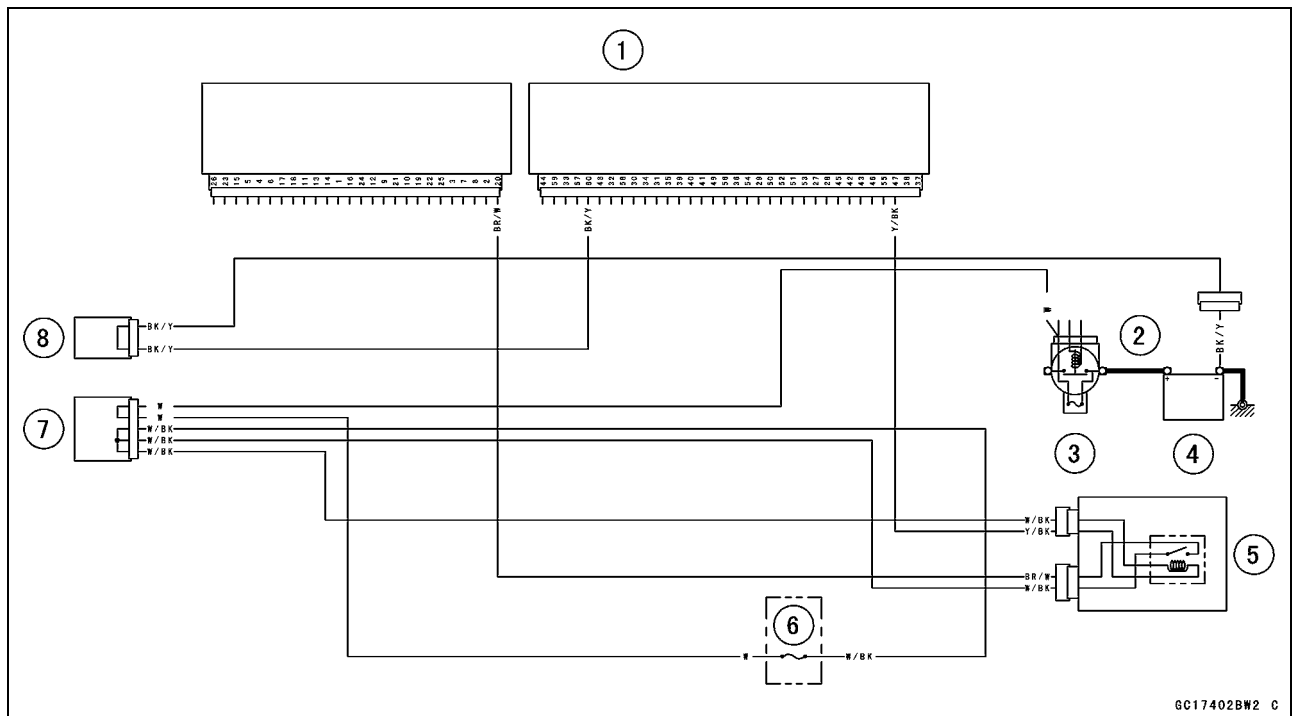

1. ECU
2. Starter Relay
3. Main Fuse 30 A
4. Battery
5. ECU Main Relay
6. ECU Fuse 15 A
7. Joint Connector 4
8. Joint Connector 2

## 3-96 FUEL SYSTEM (DFI)

### ECU

#### CAUTION

Never drop the ECU, especially on a hard surface. Such a shock to the ECU can damage it.

#### ECU Identification

Most countries have their own regulations, so each ECU has different characteristics. So, do not confuse ECU with each other and use only the ECU for your model. Otherwise, the motorcycle cannot clear the regulation.

#### ECU Identification

Part Number [A]	Specification
21175-0017	Australia, with Immobilizer
	U.K., WVTA, Full, H, with Immobilizer
	Europe, WVTA, Full, H, with Immobilizer
21175-0029	U.S.A. (except California), without Immobilizer
	Canada, without Immobilizer
21175-0031	Malaysia, with Immobilizer
21175-0032	France, WVTA, 78.2, H, with Immobilizer
21175-0033	Kuwait, WVTA, Full, H, without Immobilizer
21175-0050	U.S.A. (California), without Immobilizer

WVTA: Whole Vehicle Type Approval

Full: Full Power

H: Honeycomb Type Catalyst

78.2: Maximum Horsepower 78.2 kW (106.3 PS)

#### ECU Removal

- Remove:
  - Seats (see Frame chapter)
- Lift up the ECU [A] and relay box [B] with rubber protector [C].
- Remove:
  - ECU Lead Connectors [A]
  - ECU [B]
- Refer to the Electrical System chapter for Europe model.

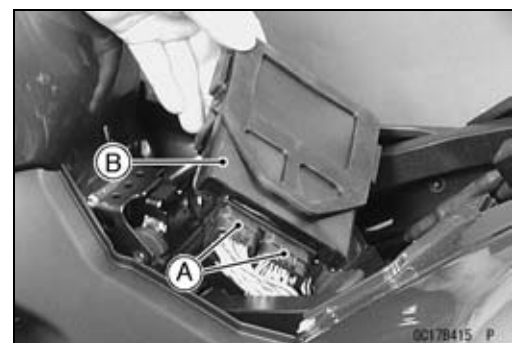
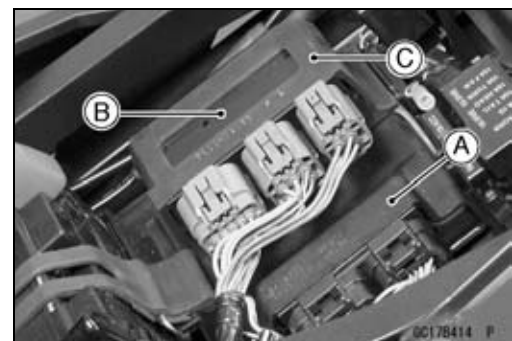
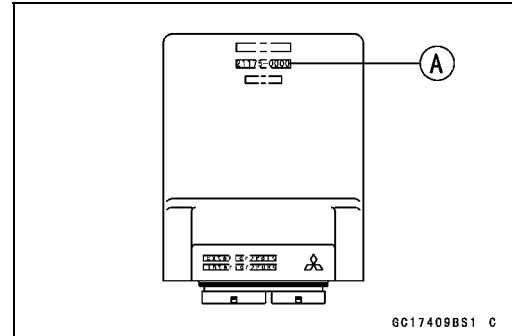

## ECU

### ECU Installation

- Install:
  - ECU [A] (In rubber protector [B])
  - ECU Lead Connectors

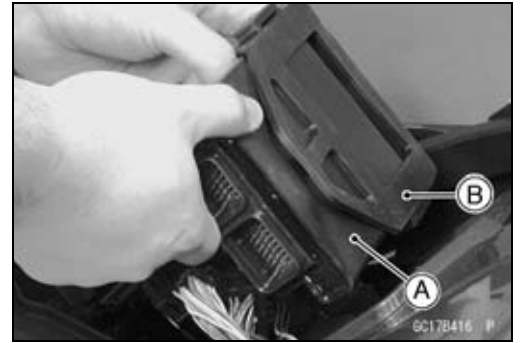

- Insert the projections [A] of the rear fender front into the slits of the rubber protector.

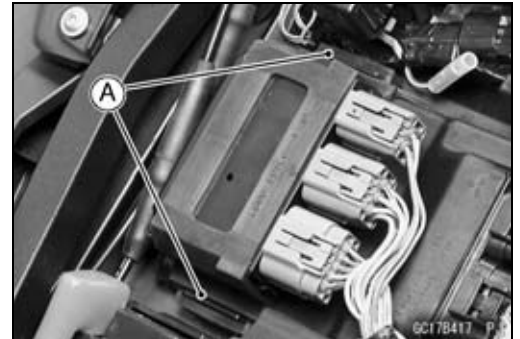

### ECU Power Supply Inspection

- Visually inspect the terminals [A] of the ECU connectors.
- ★ If the connector is clogged with mud or dust, blow it off with compressed air.
- ★ Replace the main harness if the terminals of the main harness connectors are cracked, bent, or otherwise damaged.
- ★ Replace the ECU if the terminals of the ECU connectors are cracked, bent, or otherwise damaged.

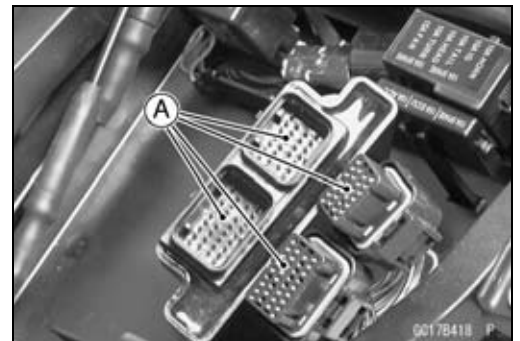

- With the ECU connectors connected, check the following ground lead for continuity with the ignition SW OFF, using a tester and needle adapter set.

**Special Tool - Needle Adapter Set: 57001-1457**

### ECU Grounding Inspection

50, 51, 59, or 60 Terminal ↔ Battery (-) Terminal: 0 Ω

Engine Ground ↔ Battery (-) Terminal: 0 Ω

- ★ If no continuity, check the connector, the engine ground lead, or main harness, and repair or replace them if necessary.

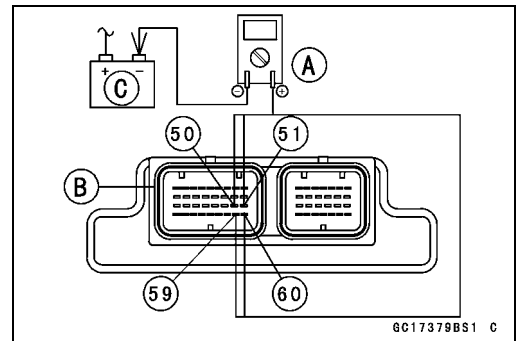

## 3-98 FUEL SYSTEM (DFI)

### ECU

- Check the ECU power source voltage with a tester [A].
  - Position the terminal in accordance with terminal numbers of ECU connectors [B] in this chapter figure.
- Battery [C]

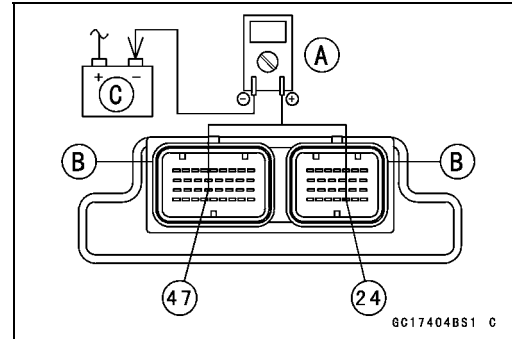

6C17404BS1 C

#### ECU Power Source Inspection

##### Tester

**Connections:** between 24 (BR) Terminal and Battery (-) Terminal  
between 47 (Y/BK) Terminal and Battery (-) Terminal

**Ignition SW OFF:** 24 (BR) Terminal 0 V,  
47 (Y/BK) Terminal Battery Voltage

**Ignition SW ON:** 24 (BR) Terminal Battery Voltage  
47 (Y/BK) Terminal about 0.8 V

- ★ If the tester does not read as specified, check the following:

- Power Source Wiring (see wiring diagram below)
- Main Fuse 30 A (see Electrical System chapter)
- ECU Fuse 15 A (see DFI Power Source section)
- ECU Main Relay (see DFI Power Source section)

#### ECU Power Source Circuit

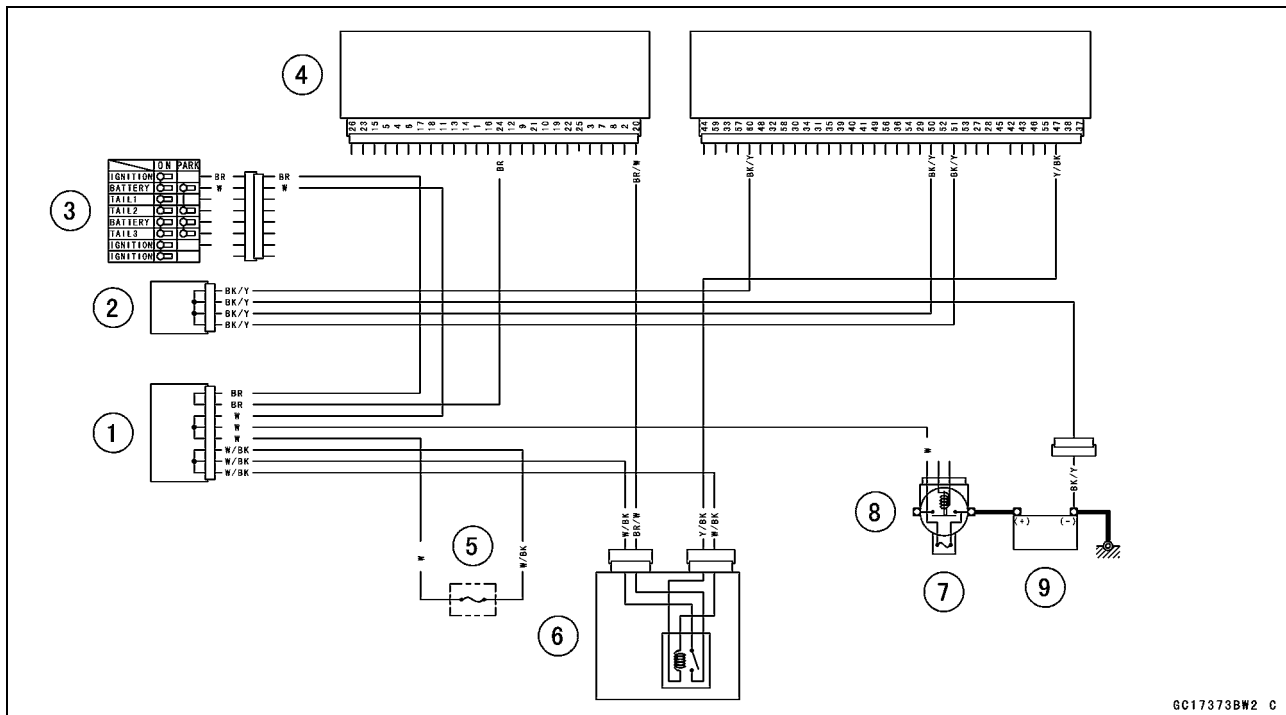

6C17373BW2 C

1. Joint Connector 4
2. Joint Connector 2
3. Ignition Switch
4. ECU
5. ECU Fuse 15 A
6. ECU Main Relay
7. Main Fuse 30 A
8. Starter Relay
9. Battery

**DFI Power Source**

---

*ECU Fuse Removal*

- Refer to the Electrical System chapter for the ECU fuse removal.

*ECU Fuse Installation*

- ★ If a fuse fails during operation, inspect the DFI system to determine the cause, and then replace it with a new fuse of proper amperage.
- Refer to the Electrical System chapter for the ECU fuse installation.

*ECU Fuse Inspection*

- Refer to the Electrical System chapter for the ECU Fuse Inspection.



## Fuel Line

### Fuel Pressure Inspection

#### NOTE

○ Be sure the battery is fully charged.

- Remove:
  - Seats (see Frame chapter)
  - Fuel Tank Bolts (see Fuel Tank Removal)
- Be sure to place a piece of cloth around the fuel supply pipe of the throttle body assembly and fuel pump.
- Remove the fuel hose (see Fuel Tank Removal).

#### ⚠ WARNING

**Be prepared for fuel spillage; any spilled fuel must be completely wiped up immediately. When the fuel hose is disconnected, fuel spills out from the hose and the pipe because of residual pressure. Cover the hose connection with a piece of clean cloth to prevent fuel spillage.**

- Install the fuel pressure gauge adapter [A] and fuel hoses (Special Tool: 57001-1607) [B] between the fuel supply pipes of the fuel pump and throttle body assy.
- Connect the pressure gauge [C] to the fuel pressure gauge adapter.

**Special Tools - Oil Pressure Gauge, 5 kgf/cm<sup>2</sup>: 57001-125  
 Fuel Pressure Gauge Adapter: 57001-1593  
 Fuel Hose: 57001-1607**

#### ⚠ WARNING

**Do not try to start the engine with the fuel hoses disconnected.**

- Turn the ignition switch ON. The fuel pump will turn for 4 seconds, and then stop.

#### CAUTION

**Do not drive the fuel pump 4 seconds or more without the fuel in the fuel tank. If the fuel pump is driven without the fuel, it may be damaged.**

- Measure the fuel pressure with the engine stopped.

#### Fuel Pressure

right after Ignition SW ON, with pump running:

Standard: 304 kPa (3.1 kgf/cm<sup>2</sup>, 44 psi)

after 4 seconds from Ignition SW ON, with pump stopped:

Standard: 280 kPa (2.9 kgf/cm<sup>2</sup>, 41 psi), residual fuel pressure

The system should hold the residual pressure about 30 seconds.

- Start the engine, and let it idle.
- Measure the fuel pressure with the engine idling.

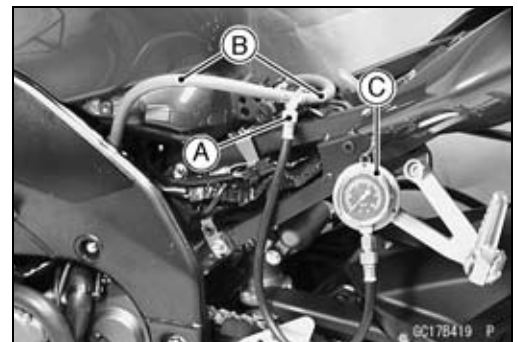

## 3-102 FUEL SYSTEM (DFI)

### Fuel Line

#### Fuel Pressure (idling)

Standard: 304 kPa (3.1 kgf/cm<sup>2</sup>, 44 psi)

#### NOTE

○The gauge hand will fluctuate. Read the pressure at the average of the maximum and minimum indications.

- ★ If the fuel pressure is much higher than the specified, replace the fuel pump.
- ★ If the fuel pressure is much lower than specified, check the following:
  - Fuel Line Leakage
  - Amount of Fuel Flow (see Fuel Flow Rate Inspection)
- ★ If the fuel pressure is much lower than specified, and if inspection above checks out good, replace the throttle body assy, or the fuel pump and measure the fuel pressure again.
- Remove the fuel pressure gauge, hoses and adapter.
- Install the fuel tank (see Fuel Tank Installation).

#### Fuel Flow Rate Inspection

#### NOTE

○Be sure the battery is fully charged.

#### **⚠ WARNING**

**Gasoline is extremely flammable and can be explosive under certain conditions. Make sure the area is well-ventilated and free from any source of flame or sparks; this includes any appliance with a pilot light. Do not smoke. Turn the ignition switch OFF. Be prepared for fuel spillage; any spilled fuel must be completely wiped up immediately.**

- Turn the ignition switch, and engine stop switch OFF.
- Wait until the engine cools down.
- Prepare a fuel hose of the inside diameter 7.5 mm (0.30 in.) and a measuring cylinder.
- Remove:
  - Seats (see Frame chapter)
  - Fuel Tank Bolts (see Fuel Tank Removal)
- Open the fuel tank cap [A] to lower the pressure in the tank.
- Be sure to place a piece of cloth around the fuel supply pipe of the fuel pump.
- Remove the fuel hose from the fuel pump (see Fuel Pump Removal).

#### **⚠ WARNING**

**Be prepared for fuel spillage; any spilled fuel must be completely wiped up immediately. When the fuel hose is disconnected, fuel spills out from the hose and the pipe because of residual pressure. Cover the hose connection with a piece of clean cloth to prevent fuel spillage.**





## Fuel Line

- Connect the prepared fuel hose [A] to the fuel supply pipe of the fuel pump.
- Secure the fuel hose with a clamp.
- Insert the fuel hose into the measuring cylinder [B].

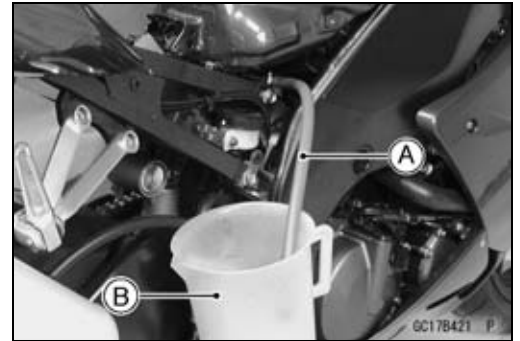

### **⚠ WARNING**

**Wipe off spilled out fuel immediately.  
Be sure to hold the measuring cylinder vertical.**

- Close the fuel tank cap.
- With the engine stopped, turn the ignition switch ON. The fuel pump should operate for 4 seconds, and then should stop.

### **CAUTION**

**Do not drive the fuel pump 4 seconds or more without the fuel in the fuel tank. If the fuel pump is driven without the fuel, it may be damaged.**

- Measure the discharge for 4 seconds.
- Repeat this operation several times.

#### **Amount of Fuel Flow**

**Standard: 72 mL (2.43 US oz) or more for 4 seconds**

- ★ If the fuel flow is much less than the specified, check the following:

Battery Condition (see Electrical System chapter)

- After inspection, connect the fuel hoses (see Fuel Tank Installation).
- Start the engine and check for fuel leakage.

## 3-104 FUEL SYSTEM (DFI)

### Fuel Pump

#### Fuel Pump Removal

#### CAUTION

Never drop the fuel pump, especially on a hard surface. Such a shock to the pump can damage it.

#### ⚠ WARNING

Gasoline is extremely flammable and can be explosive under certain conditions. Make sure the area is well-ventilated and free from any source of flame or sparks; this includes any appliance with a pilot light. Do not smoke. Turn the ignition switch OFF. Disconnect the battery (-) terminal.

To make fuel spillage minimum, draw the fuel out from the fuel tank when the engine is cold. Be prepared for fuel spillage; any spilled fuel must be completely wiped up immediately.

- Draw the fuel out from the fuel tank with a commercially available electric pump.
- Remove the fuel tank (see Fuel Tank Removal).
- Be careful of fuel spillage from the fuel tank since fuel still remains in the fuel tank and fuel pump. Plug the fuel pipe of the fuel tank.
- Turn the fuel tank upside down.
- Unscrew the fuel pump bolts [A], and take out the fuel pump assembly [B] and gasket.
- Discard the fuel pump gasket.

#### CAUTION

Do not pull the leads [C] of the fuel pump and fuel reserve switch. If they are pulled, the lead terminals may be damaged.

#### Fuel Pump Installation

- Remove dirt or dust from the fuel pump [A] by lightly applying compressed air.
- Replace the fuel pump gasket with a new one.

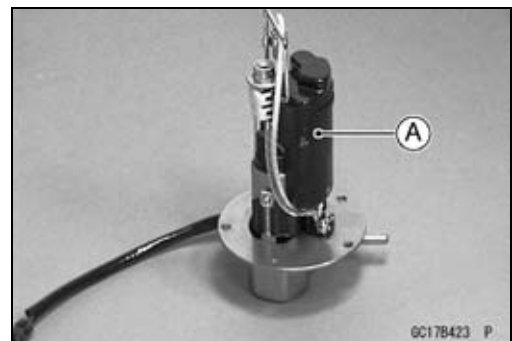
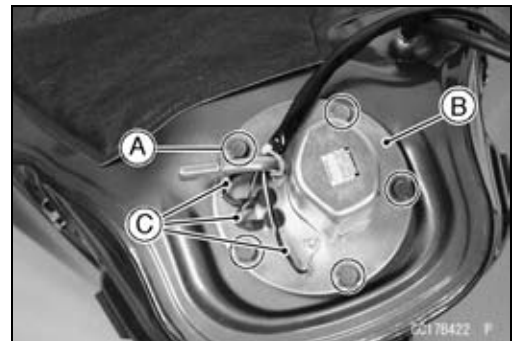

**Fuel Pump**

- Check that the fuel pump terminals [A], fuel reserve switch terminal [B] and band [C] are in place.  
[D] Front
- Apply a non-permanent locking agent to the threads of the fuel pump bolts.
- Tighten the fuel pump bolts to a snug fit following the tightening sequence shown.
- Following the tightening sequence, tighten the pump bolts to the specified torque.

**Torque - Fuel Pump Bolts: 9.8 N·m (1.0 kgf·m, 87 in·lb)**

- Tighten the pump bolts again to check the tightness in the order shown.

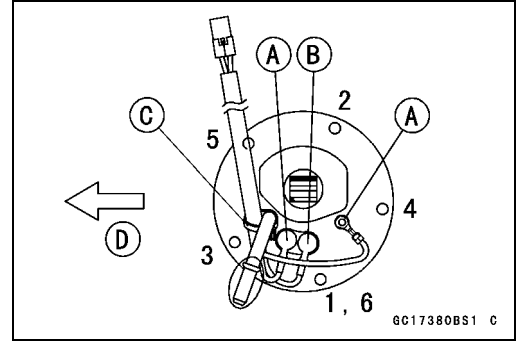

*Operation Inspection*

**NOTE**

○Be sure the battery is fully charged.

- Turn the ignition switch ON and make sure that the fuel pump operates (make light sounds) for 4 seconds, and then stops.
- Turn the ignition switch OFF.
- ★If the pump does not work as described above, inspect the operating voltage.

*Operating Voltage Inspection*

**NOTE**

○Be sure the battery is fully charged.

- Turn the ignition switch OFF.
- Remove the fuel tank bolts and lift up the fuel tank.
- Connect the hand tester (25 V DC) to the connector [A], with needle adapter set.

**Special Tools - Hand Tester: 57001-1394**

**Needle Adapter Set: 57001-1457**

- Measure the operating voltage with the engine stopped, and with the connector joined.
- Turn the ignition switch ON.
- The tester needle should indicate battery voltage for 4 seconds, and then 0 V.

**Pump Operating Voltage at Pump Connections to Pump Connectors**

**Tester (+) → Y/R Lead**

**Tester (-) → BK/W Lead**

**Operating Voltage at Pump Connector**

**Standard: Battery Voltage for 4 seconds, and then 0 V**

- ★If the reading stays on battery voltage, and never shows 0 V. Check the ECU and fuel pump relay.
- ★If the voltage is in specification, but the pump doesn't work, replace the pump.
- ★If there is still no battery voltage, check the pump relay (see this chapter).



# 3-106 FUEL SYSTEM (DFI)

## Fuel Pump

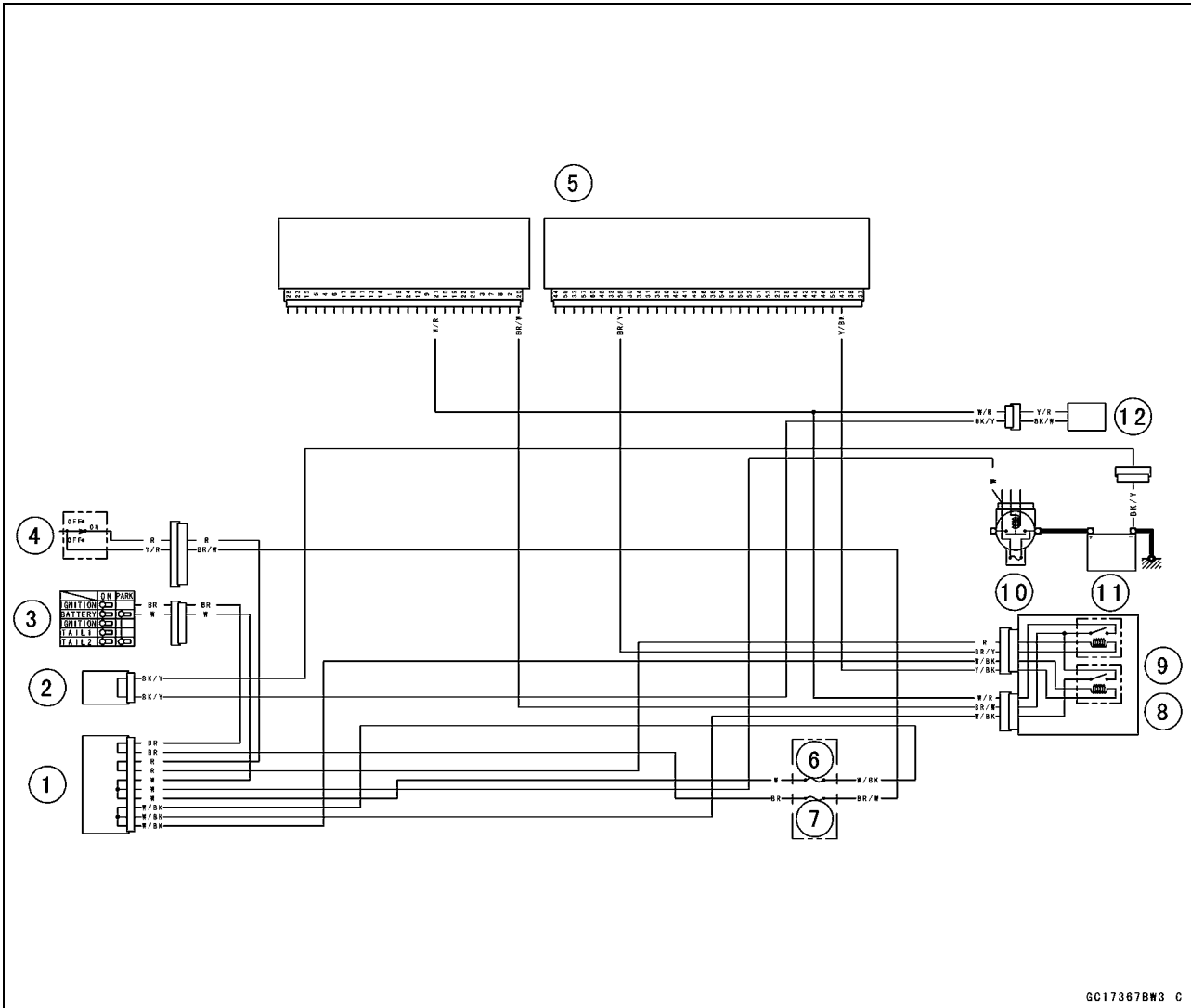

1. Joint Connector 4
2. Joint Connector 1
3. Ignition Switch
4. Engine Stop Switch
5. ECU
6. ECU Fuse 15 A
7. Ignition Fuse 10 A
8. ECU Main Relay
9. Fuel Pump Relay
10. Main Fuse 30 A
11. Battery
12. Fuel Pump

---

## Throttle Grip and Cables

---

### *Free Play Inspection*

- Refer to the Throttle Control System Inspection in the Periodic Maintenance chapter.

### *Free Play Adjustment*

- Refer to the Throttle Control System Inspection in the Periodic Maintenance chapter.

### *Cable Installation*

- Install the throttle cables in accordance with the Cable Routing section in the Appendix chapter.
- Install the lower ends of the throttle cables in the cable bracket on the throttle assy after installing the upper ends of the throttle cables in the grip.
- After installation, adjust each cable properly.

**⚠ WARNING**

**Operation with incorrectly routed or improperly adjusted cables could result in an unsafe riding condition.**

### *Cable Lubrication*

- Refer to the General Lubrication Perform in the Periodic Maintenance chapter.

## 3-108 FUEL SYSTEM (DFI)

### Throttle Body Assy

#### Idle Speed Inspection

- Refer to the Idle Speed Inspection in the Periodic Maintenance chapter .

#### Throttle Bore Cleaning

- Check the throttle bore for cleanliness as follows:
  - Remove:
    - Throttle Body (see Fuel System (DFI) chapter)
  - Check the main throttle valves and throttle bores [A] for carbon deposits by opening the main throttle valves.
  - ★ If any carbon accumulates, wipe the carbon off the throttle bores around the throttle bores and the throttle valves, using a cotton pad penetrated with a high-flash point solvent. Be careful not to remove molybdenum disulfide coat (black) [B] from the throttle valves and the bores.

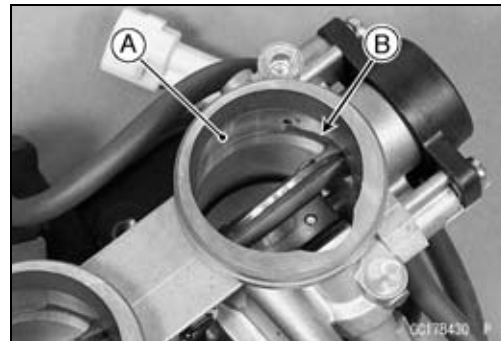

#### CAUTION

**Do not rub these surfaces hard and so not use a carburetor cleaning solution, which damage molybdenum disulfide coat; instead, use a high-flash point cleaning solution and wipe slowly.**

#### Synchronization Inspection

- Refer to the Engine Vacuum Synchronization Inspection in the Periodic Maintenance chapter.

#### Synchronization Adjustment

- Refer to the Engine Vacuum Synchronization Inspection in the Periodic Maintenance chapter.

#### Throttle Body Assy Removal

#### ⚠ WARNING

**Gasoline is extremely flammable and can be explosive under certain conditions. Turn the ignition switch OFF. Disconnect the battery (-) cable terminal. Do not smoke. Make sure the area is well-ventilated and free from any source of flame or sparks; this includes any appliance with a pilot light.**

**Be prepared for fuel spillage: any spilled fuel must be completely wiped up immediately.**

- Remove:
  - Fuel Tank (see Fuel Tank Removal)
  - Air Cleaner Housing (see Air Cleaner Housing Removal)
- Be sure to place a piece of cloth around the fuel supply pipe [A] of the throttle body assembly.
- Remove:
  - Four Connectors [B]

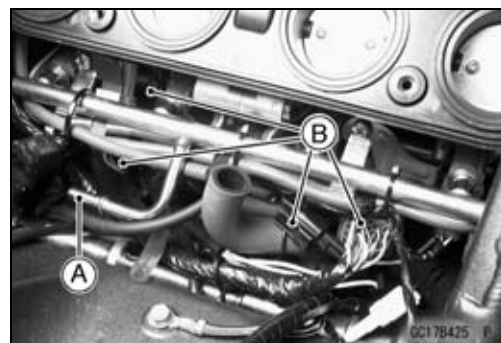

## Throttle Body Assy

- Remove:
  - Vacuum Switch Valve Vacuum Hose [A]
  - Four Connectors [B]
  - Vacuum Hose (California Model)

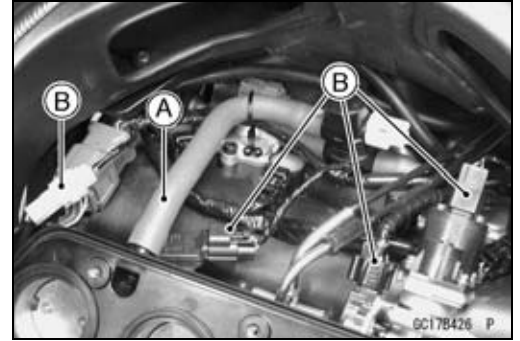

- Remove:
  - Middle Fairings (see Frame chapter)
- Loosen:
  - Clamp Bolts [A] (both side)
- Remove the throttle body assembly with cables from holder.

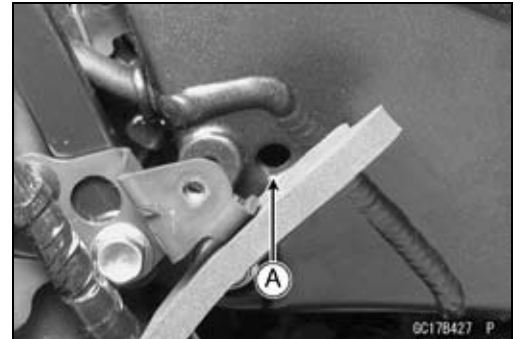

- Remove the throttle case [A] to make a throttle cable slack.
- Remove:
  - Throttle Cable Lower Ends



- After removing the throttle body assy, stuff pieces of lint-free, clean cloths into the throttle body holders.

**CAUTION**

**If dirt gets into the engine, excessive engine wear and possible engine damage will occur.**

### *Throttle Body Assy Installation*

- Install the holder clamp bolts [A] in the direction as shown.
  - [B] Bolt Heads
- Tighten:
  - Torque - Throttle Body Assembly Holder Clamp Bolts: 2.0 N·m (0.20 kgf·m, 18 in·lb)**
- Run the vacuum hoses as shown in the Cable, Wire, and Hose Routing section of the Appendix chapter.
- When installing the fuel hose, refer to Fuel Tank Installation.
- Adjust:
  - Throttle Grip Free Play
  - Idle Speed

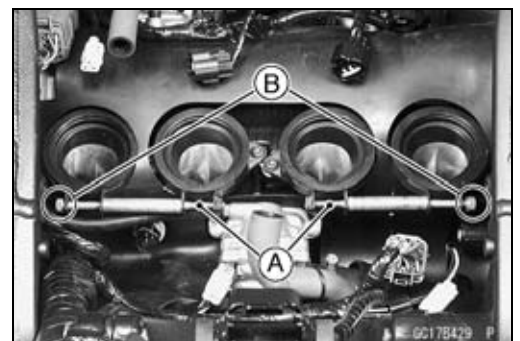

## 3-110 FUEL SYSTEM (DFI)

### Throttle Body Assy

#### Throttle Body Assy Disassembly

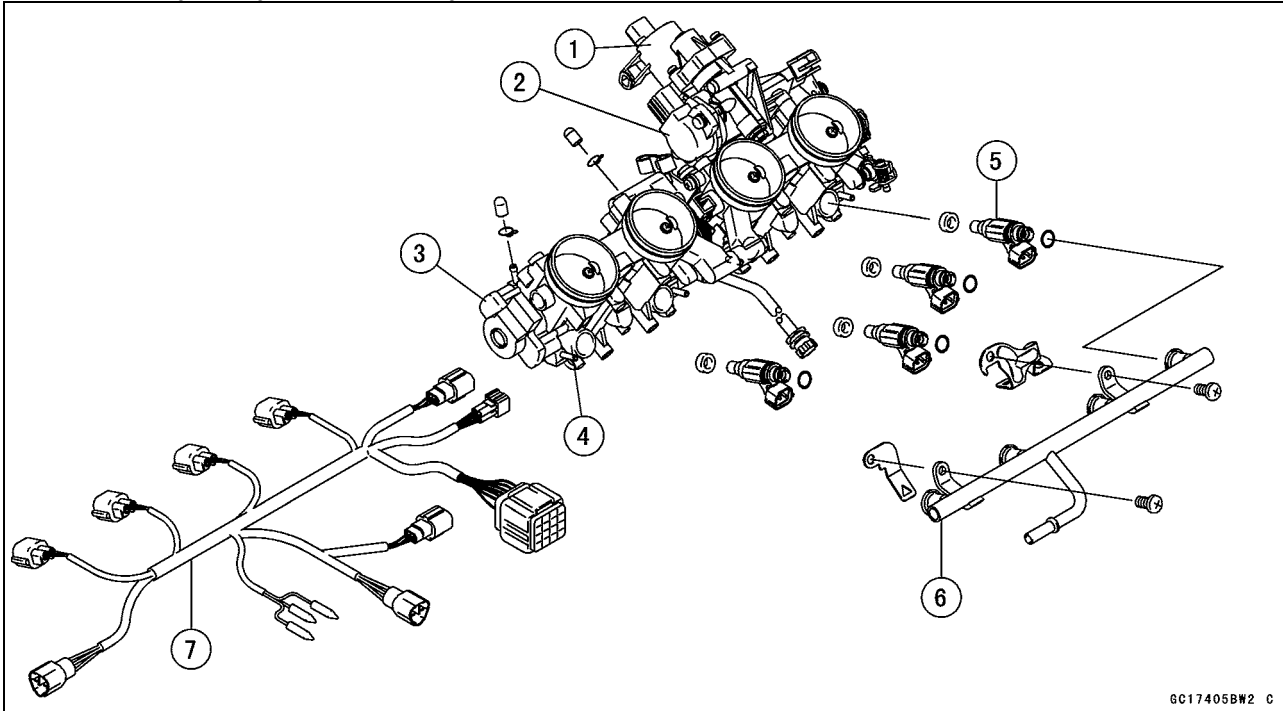

GC17405BW2 C

1. Subthrottle Valve Actuator
2. Subthrottle Valve
3. Main Throttle Valve
4. Throttle Body Assy
5. Injector
6. Delivery Pipe Assy
7. Injector Connector Harness

#### CAUTION

**Do not remove, disassemble or adjust the main throttle sensor, subthrottle sensor, subthrottle valve actuator, throttle link mechanism and throttle body assy, because they are adjust or set surely at the manufacturer. Adjustment of these parts could result in poor performance, requiring replacement of the throttle body assy.**

- Remove the throttle body assembly (see Throttle Body Assy Removal).
- Remove the screws [A] to pull out the injector assys from the throttle body assy together with the delivery pipe [B].

#### NOTE

○ Do not damage the part of insert of the injectors when they are pulled out from the throttle body.

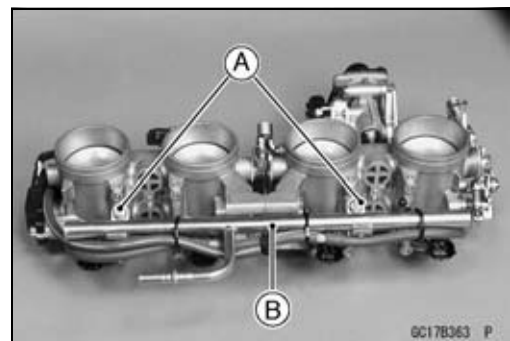

GC178363 P



## Throttle Body Assy

- Pull out the injectors [A] from the delivery pipe [B].

### NOTE

- Do not damage the part of insert of the injectors when they are pulled out from the delivery pipe.

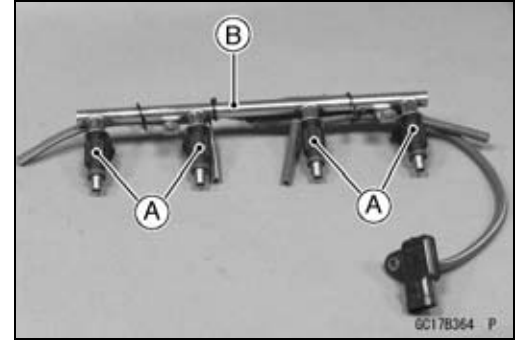

### Throttle Body Assy Assembly

- Before assembling, blow away dirt or dust from the throttle body and delivery pipe by applying compressed air.
- Apply daphne oil or engine oil to the new O-rings [A] of each injector, insert them to the delivery pipe [B] and confirm whether the injectors turn smoothly or not.

### NOTE

- Replace the O-ring of injectors and the dust seals of delivery pipe to new one.

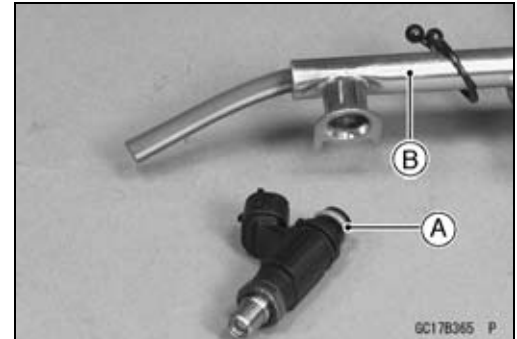

- Apply daphne oil or engine oil to the new dust seals [A], insert the injectors installed to the delivery pipe to the throttle body.

### NOTE

- Replace the dust seals of the throttle body to new one.

- Install the delivery pipe assy to the throttle body.

**Torque - Delivery Pipe Mounting Screws: 4.9 N·m (0.50 kgf·m, 43 in·lb)**

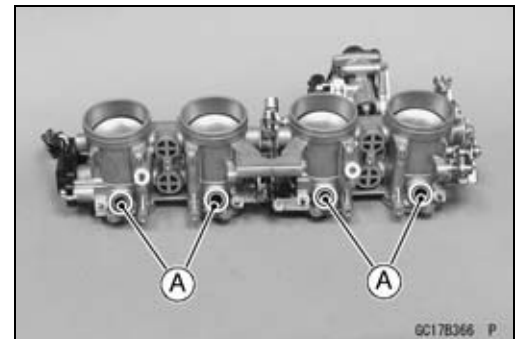

- Install the injector connectors to each injector, and bind the connector lead with clamps [A].
- Insert the each hoses to the throttle body fittings.
- Install the throttle body assy (see Throttle Body Assy Installation).

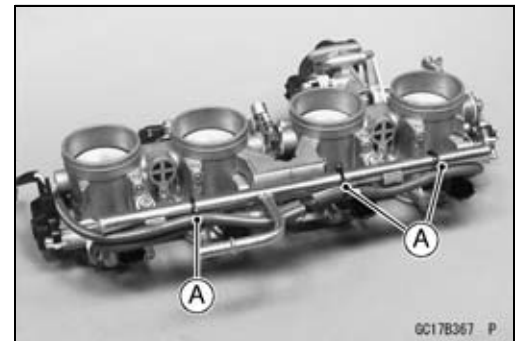

## 3-112 FUEL SYSTEM (DFI)

### Air Line

#### *Element Removal*

- Refer to the Air Cleaner Element Replacement in the Periodic Maintenance chapter.

#### *Element Installation*

- Refer to the Air Cleaner Element Replacement in the Periodic Maintenance chapter.

#### *Air Cleaner Element Inspection*

- Remove the air cleaner element (see Periodic Maintenance chapter).
- Visually check the element [A] for tears or breaks.
- ★ If the element has any tears or breaks, replace the element.

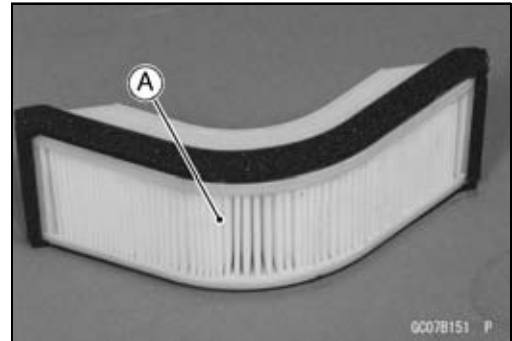

#### *Air Cleaner Housing Removal*

- Remove:
  - Air Cleaner Element [A] (see Periodic Maintenance chapter)
  - Inlet Air Temperature Sensor [B]

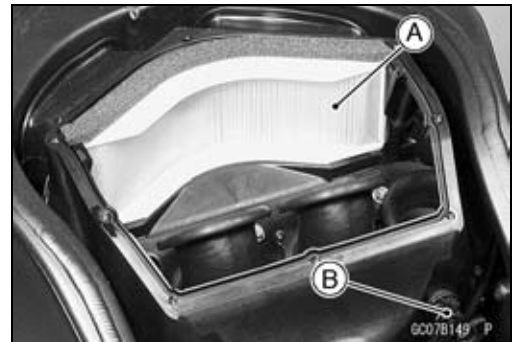

- Remove:
  - Air Cleaner Housing Bolts [A]



- Remove:
  - Hoses [A]
  - Air Cleaner Housing [B] (from air ducts and holders)

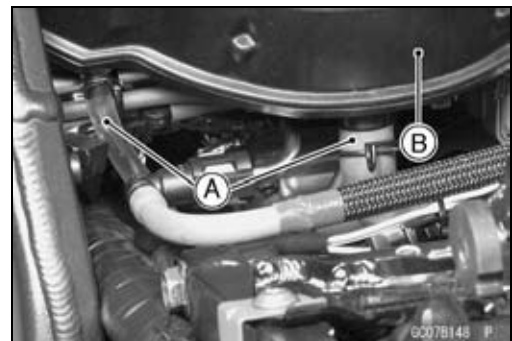

**Air Line**

- Turn the air cleaner housing [A] counterclockwise [B] and remove it.

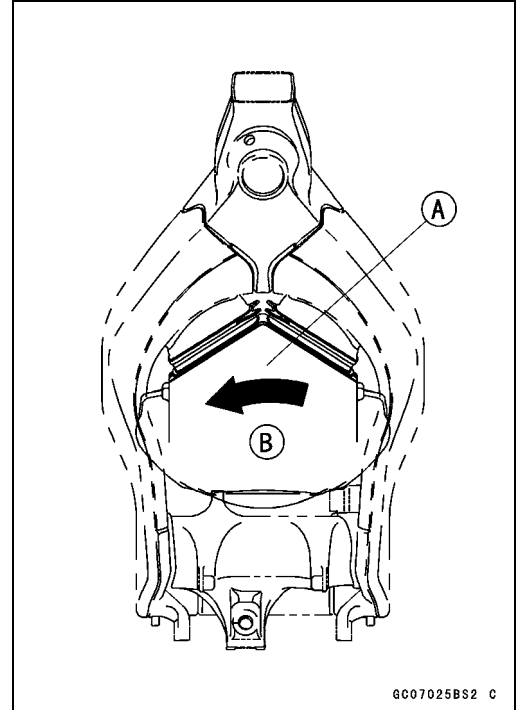

**Air Cleaner Housing Installation**

- Confirm the air ducts [A] fit in the frame [B].
- Insert the air cleaner housing [C] inside the frame as shown.
- Turn the housing clockwise and position it.

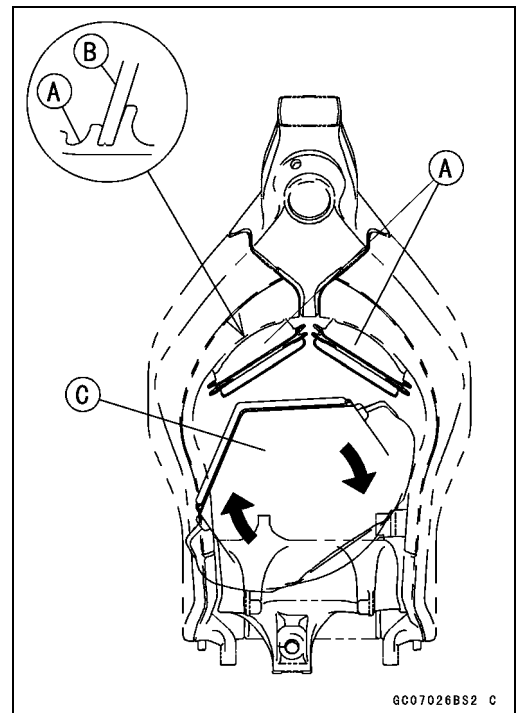

- Install the housing on the holder then insert the ducts.
- Insert the projections [A] of the housing in the holes [B] of the ducts.
- Tighten the air cleaner housing bolts and install the air cleaner element (see Periodic Maintenance chapter).

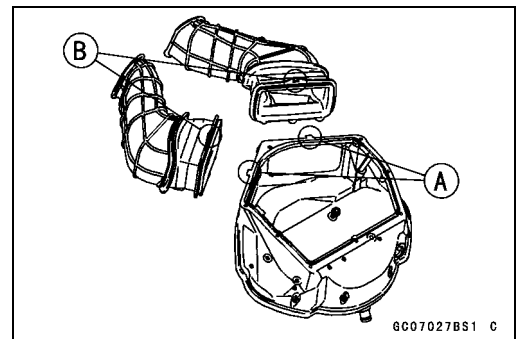

## 3-114 FUEL SYSTEM (DFI)

### Air Line

#### Air Cleaner Housing Disassembly

- Remove:
  - Air Cleaner Housing (Air Cleaner Housing Removal)
  - Air Cleaner Housing Screws [A]
  - Lower Housing [B]
  - Duct Holder Screws [C]
  - Ducts and Duct Holders
  - Filter

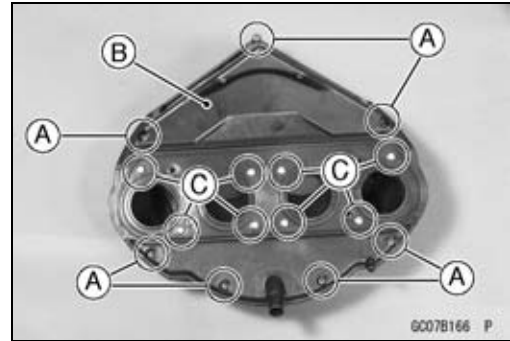

#### Air Cleaner Housing Assembly

- Install:
  - Ducts [A] and Duct Holders [B] (as shown)
  - Filter [C]
- ★ If the filter is dirt, clean the filter in cleaning solvent, and then dry it with compressed air or squeeze it.

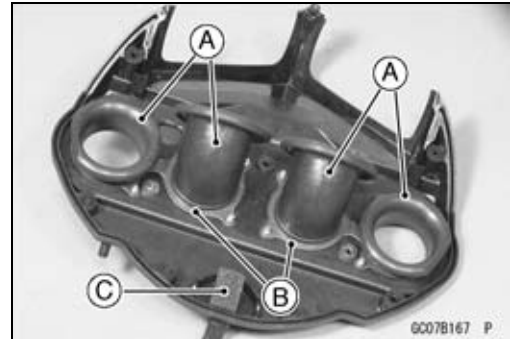

- Insert the seal [A] into the groove in the lower housing [B].
- Apply adhesive to the mesh patterns [C] on the lower housing.

**Adhesive-Cemedine Super X NO. 8008 (Black)**

- Wipe off any protruding adhesive.
- Fit the upper and lower housings, and tighten the screws securely.

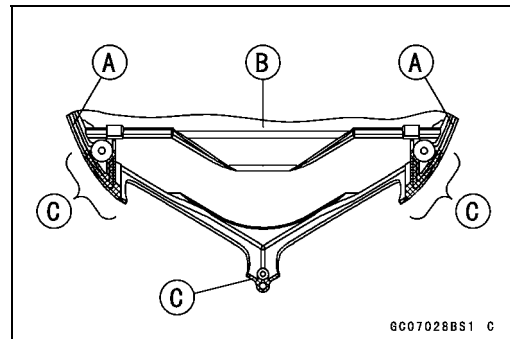

#### Oil Draining

A drain hose is connected to the bottom of the air cleaner part to drain water or oil accumulated in the cleaner part.

- Visually check the drain hose end [A], if the water or oil accumulates in the hose.
- ★ If any water or oil accumulates in the hose, remove the plug [B] from the drain hose and drain it.

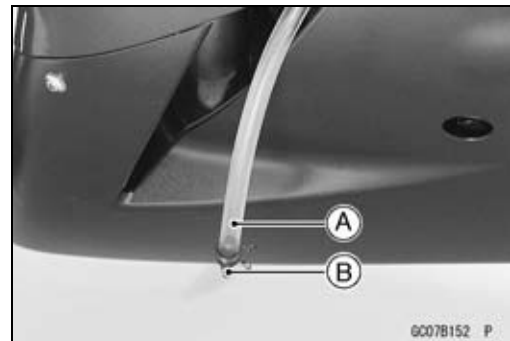

### **⚠ WARNING**

**Be sure reinstall the plug in the drain hose after draining. Oil on tires will make them slippery and can cause an accident and injury.**

### Air Line

#### *Air Inlet Duct Removal*

- Remove:
  - Upper Fairing (see Frame chapter)
  - Mounting Bolts [A]
  - Air Inlet Duct [B]

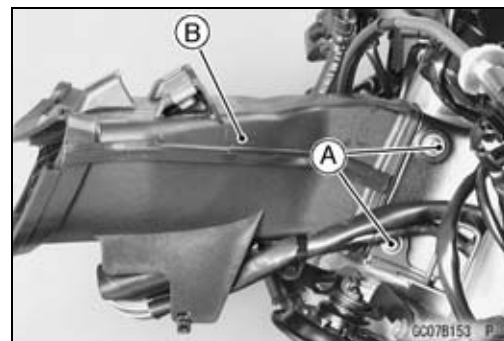

#### *Air Inlet Duct Installation*

- Tighten:
  - Torque - Air Inlet Duct Mounting Bolts: 7.0 N·m (0.70 kgf·m, 62 in·lb)**

## 3-116 FUEL SYSTEM (DFI)

### Fuel Tank

#### Fuel Tank Removal

#### **⚠ WARNING**

Gasoline is extremely flammable and can be explosive under certain conditions. Make sure the area is well-ventilated and free from any source of flame or sparks; this includes any appliance with a pilot light. Do not smoke. Turn the ignition switch OFF. Be prepared for fuel spillage; any spilled fuel must be completely wiped up immediately.

- Turn the ignition switch OFF.
- Remove:
  - Seats (see Frame chapter)
- Disconnect the battery (–) terminal.
- Wait until the engine cools down.
- Remove:
  - California Fuel Return Hose (front, red)
  - California Fuel Tank Breather Hose (rear, blue)
  - Fuel Tank Bolts [A]
  - Drain Hose [B]
- Open the fuel tank cap [A] to lower the pressure in the tank.
- During tank removal, keep the tank cap open to release pressure in the tank. This makes fuel spillage less.
- Draw the fuel out from the fuel tank with a commercially available pump [A].
- Use a soft plastic hose [B] as a pump inlet hose in order to insert the hose smoothly.
- Put the hose through the fill opening [C] into the tank and draw the fuel out.
  - Front [D]

#### **⚠ WARNING**

The fuel could not be removed completely from the fuel tank. Be careful for remained fuel spillage.

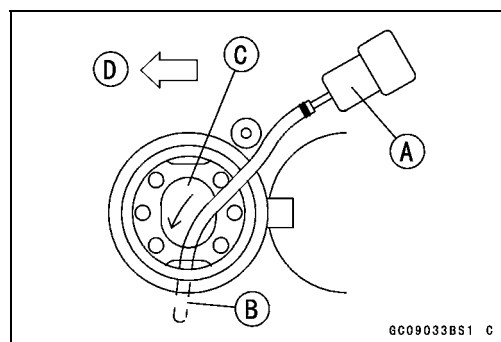

**Fuel Tank**

- Disconnect the fuel pump lead connector [A].

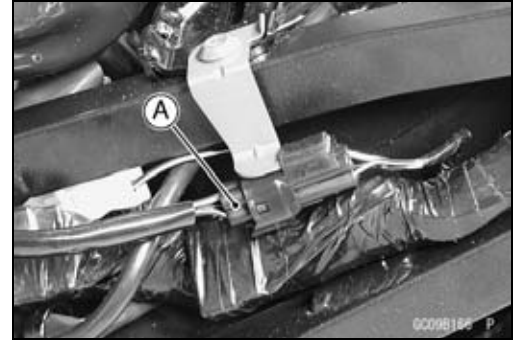

- Be sure to place a piece of cloth [A] around the fuel hose joint [B].
- Push [C] the joint lock claws [D].

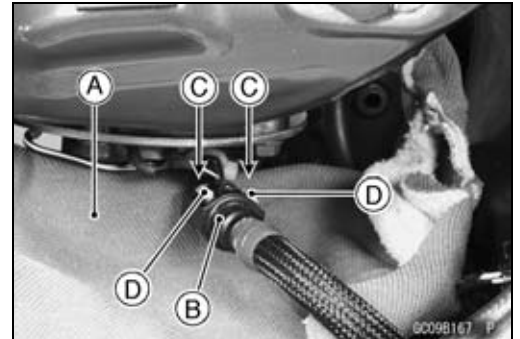

- Pull [A] the joint lock [B] as shown.
- Pull the fuel hose joint [C] out of the delivery pipe.

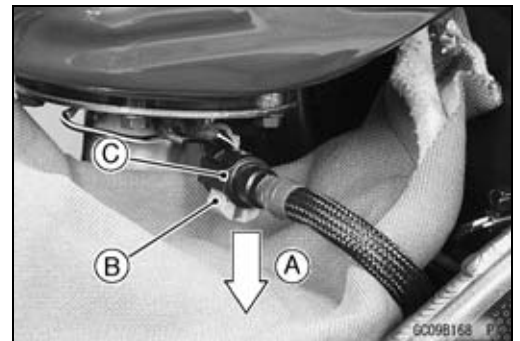

**⚠ WARNING**  
**Be prepared for fuel spillage; any spilled fuel must be completely wiped up immediately. When the fuel hose is disconnected, fuel spills out from the hose and the pipe because of residual pressure. Cover the hose connection with a piece of clean cloth to prevent fuel spillage.**

- Close the fuel tank cap.
- Remove the fuel tank, and place it on a flat surface.

- For California Model, note the following:

**CAUTION**  
**For California model, if gasoline, solvent, water or any other liquid enters the canister, the canister's vapor absorbing capacity is greatly reduced. If the canister does become contaminated, replace it with a new one.**

- Be sure to plug the evaporative fuel return hose to prevent fuel spilling before fuel tank removal.

**⚠ WARNING**  
**For California model, be careful not to spill the gasoline through the return hose. Spilled fuel is hazardous.**

- ★ If liquid or gasoline flows into the breather hose, remove the hose and blow it clean with compressed air (California model).

- Be careful of fuel spillage from the fuel tank since fuel still remains in the fuel tank and fuel pump.

**⚠ WARNING**  
**Store the fuel tank in an area which is well-ventilated and free from any source of flame or sparks. Do not smoke in this area. Place the fuel tank on a flat surface and plug the fuel pipes to prevent fuel leakage.**

## 3-118 FUEL SYSTEM (DFI)

### Fuel Tank

#### Fuel Tank Installation

- Note the above WARNING (see Fuel Tank Removal).
- Route the hoses correctly (see Appendix chapter).
- Check that the dampers [A] and pad [B] are in place on the fuel tank as well.
- ★ If the dampers are damaged or deteriorated, replace them.
- ★ If the dampers are damaged or deteriorated, replace them.
- For California Model, note the following:
  - To prevent the gasoline from flowing into or out of the canister, hold the separator perpendicular to the ground.
  - Connect the hoses according to the diagram of the system (see Cable, Wire, and Hose Routing section in the Appendix chapter). Make sure they do not get pinched or kinked.
  - Route hoses with a minimum of bending so that the air or vapor will not be obstructed.

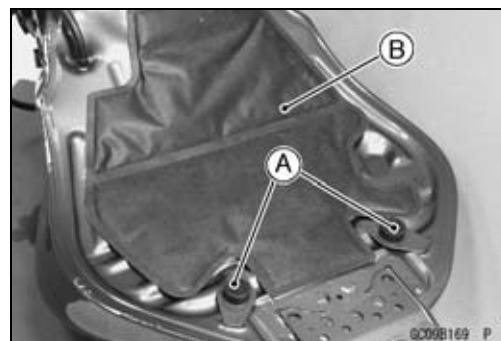
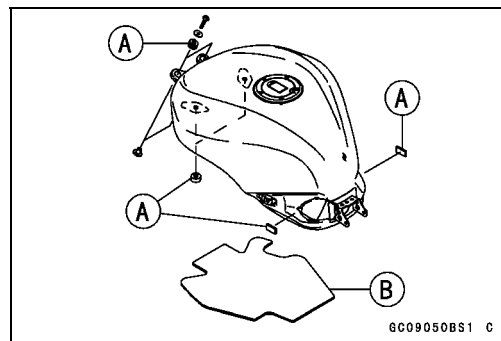

- Pull [A] the joint lock [B] as shown.

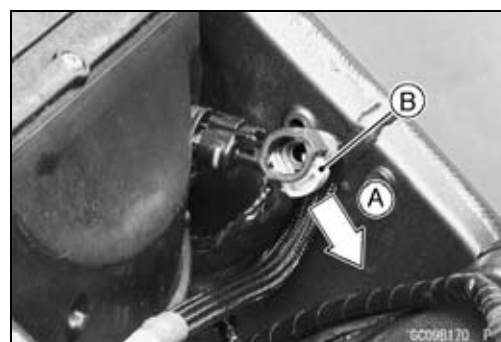

- Insert the fuel hose joint [A] straight onto the delivery pipe until the hose joint clicks.
- Push [B] the joint lock [C] until the hose joint clicks.

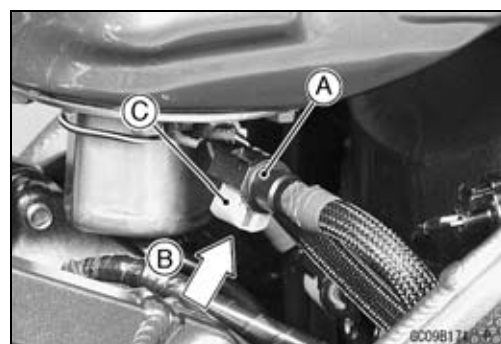

- Push and pull [A] the hose joint [B] back and forth more than two times and make sure it is locked and doesn't come off. When the hose joint is correctly installed, it should slide on the delivery pipe about 5 mm (0.2 in.).

#### **⚠ WARNING**

**Make sure the hose joint is installed correctly on the delivery pipe by sliding the joint, or the fuel could leak.**

- ★ If it does not slide, reinstall the hose joint.
- Connect the fuel pump and the fuel level sensor connectors and the battery (-) lead terminal.

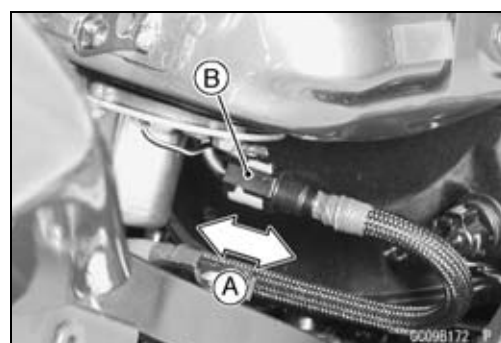



## Fuel Tank

### *Fuel Tank and Cap Inspection*

- Visually inspect the gasket [A] on the tank cap for any damage.
- ★ Replace the gasket if it is damaged.
- Check to see if the water drain pipe [B] and fuel breather pipe [C] (California model) in the tank are not clogged. Check the tank cap breather also.
- ★ If they are clogged, remove the tank and drain it, and then blow the breather free with compressed air.

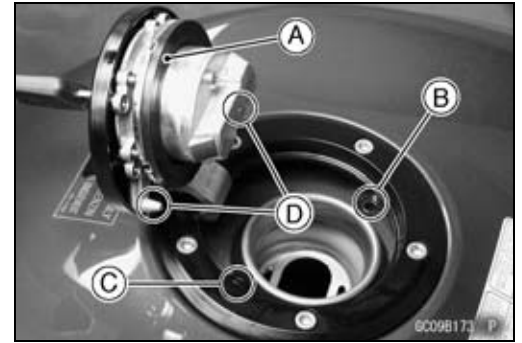

### CAUTION

**Do not apply compressed air to the air vent holes [D] in the tank cap. This could cause damage and clogging of the labyrinth in the cap.**

### *Fuel Tank Cleaning*

#### **⚠ WARNING**

**Clean the tank in a well-ventilated area, and take care that there are no sparks or flame anywhere near the working area. Because of the danger or highly flammable liquids, do not use gasoline or low-flash point solvents to clean the tank.**

- Remove the fuel tank (see Fuel Tank Removal).
- Remove the fuel pump inlet hose and the fuel pump (see Fuel Pump section in this chapter).
- Pour some high flash-point solvent into the fuel tank and shake the tank to remove dirt and fuel deposits.
- Draw the solvent out of the fuel tank.
- Dry the tank with compressed air.
- Install the fuel pump (see Fuel Pump Installation).
- Install the fuel tank (see Fuel Tank Installation).

## 3-120 FUEL SYSTEM (DFI)

### Evaporative Emission Control System

The Evaporative Emission Control System routes fuel vapors from the fuel system into the running engine or stores the vapors in a canister when the engine is stopped. Although no adjustments are required, a thorough visual inspection must be made at the intervals specified by the Periodic Maintenance Chart.

#### *Parts Removal/Installation*

#### **⚠ WARNING**

**Gasoline is extremely flammable and can be explosive under certain conditions. Turn the ignition switch OFF. Do not smoke. Make sure the area is well-ventilated and free from any source of flame or sparks; this includes any appliance with a pilot light.**

#### **CAUTION**

**If gasoline, solvent, water or any other liquid enters the canister, the canister's vapor absorbing capacity is greatly reduced. If the canister does become contaminated, replace it with a new one.**

- To prevent the gasoline from flowing into or out of the canister, hold the separator perpendicular to the ground.
- Connect the hoses according to the diagram of the system. Make sure they do not get pinched or kinked.

#### *Hose Inspection*

- Refer to the Evaporative Emission Control System Inspection in the Periodic Maintenance chapter.

#### *Separator Inspection*

- Refer to the Evaporative Emission Control System Inspection in the Periodic Maintenance chapter.

[A] Separator



Evaporative Emission Control System

Separator Operation Test

**⚠ WARNING**

**Gasoline is extremely flammable and can be explosive under certain conditions. Turn the ignition switch OFF. Do not smoke. Make sure the area is well-ventilated and free from any source of flame or sparks; this includes any appliance with a pilot light.**

- Connect the hoses to the separator, and install the separator on the motorcycle.
- Disconnect the breather hose from the separator, and inject about 20 mL of gasoline [A] into the separator [B] through the hose fitting.
- Disconnect the fuel return hose [C] from the fuel tank [D].
- Run the open end of the return hose into the container and hold it level with the tank top [E].
- Start the engine, and let it idle.
- ★ If the gasoline in the separator comes out of the hose, the separator works well. If it does not, replace the separator with a new one.

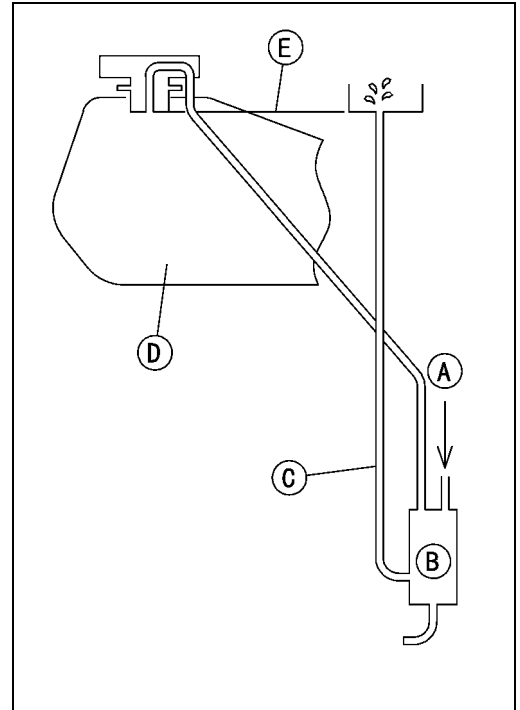

Canister Inspection (California Model Only)

- Refer to the Evaporative Emission Control System Inspection in the Periodic Maintenance chapter.

**NOTE**

○ The canister [A] is designed to work well through the motorcycle's life without any maintenance if it is used under normal conditions.

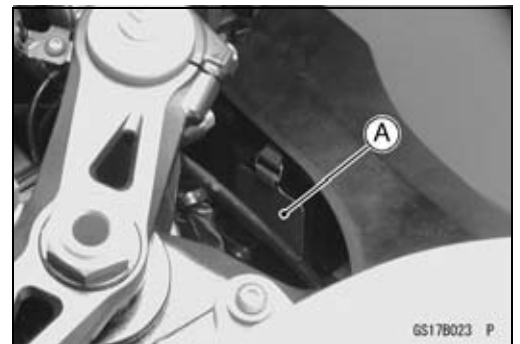



# Cooling System

## Table of Contents

Exploded View .....	4-2
Coolant Flow Chart.....	4-4
Specifications .....	4-6
Coolant .....	4-7
Coolant Deterioration Inspection.....	4-7
Coolant Level Inspection.....	4-7
Coolant Draining .....	4-7
Coolant Filling .....	4-7
Pressure Testing .....	4-7
Cooling System Flushing .....	4-8
Coolant Reserve Tank Removal/Installation .....	4-8
Water Pump.....	4-9
Water Pump Removal.....	4-9
Water Pump Installation.....	4-9
Water Pump Impeller Inspection.....	4-10
Radiator .....	4-11
Radiator and Radiator Fan Removal .....	4-11
Radiator and Radiator Fan Installation .....	4-12
Radiator Inspection .....	4-13
Radiator Cap Inspection .....	4-13
Radiator Filler Neck Inspection .....	4-14
Thermostat .....	4-15
Thermostat Removal.....	4-15
Thermostat Installation.....	4-15
Thermostat Inspection .....	4-15
Hoses and Pipes .....	4-17
Hose Installation .....	4-17
Hose Inspection .....	4-17
Water Temperature Sensor .....	4-18
Water Temperature Sensor Removal.....	4-18
Water Temperature Sensor Inspection .....	4-18



**Exploded View**

No.	Fastener	Torque			Remarks
		N·m	kgf·m	ft·lb	
1	Water Hose Clamp Screws	2.0	0.20	17 in·lb	
2	Coolant Drain Plug (Water Pump)	9.8	1.0	87 in·lb	
3	Coolant Drain Plug (Cylinder)	9.8	1.0	87 in·lb	
4	Coolant Drain Plug (Lower Crankcase)	9.8	1.0	87 in·lb	
5	Water Pump Cover Bolts	9.8	1.0	87 in·lb	
6	Oil Cooler Mounting Bolts	20	2.0	14	
7	Water Passage Plugs	20	2.0	14	L
8	Thermostat Housing Cover Bolts	6.0	0.61	53 in·lb	
9	Thermostat Housing Mounting Bolts	9.8	1.0	87 in·lb	
10	Radiator Upper Bolt	7.0	0.70	61 in·lb	
11	Radiator Lower Bolt	7.0	0.70	61 in·lb	
12	Radiator Bracket Mounting Bolt	7.0	0.70	61 in·lb	
13	Coolant Reserve Tank Mounting Screws	9.8	1.0	87 in·lb	
14	Water Hose Fitting Bolts	9.8	1.0	87 in·lb	
15	Coolant By-pass Fitting Bolt	8.8	0.90	78 in·lb	L
16	Water Temperature Sensor	25	2.5	18	

17. Thermostat

18. California Model

G: Apply grease.

L: Apply a non-permanent locking agent.

R: Replacement Parts

# 4-4 COOLING SYSTEM

## Coolant Flow Chart

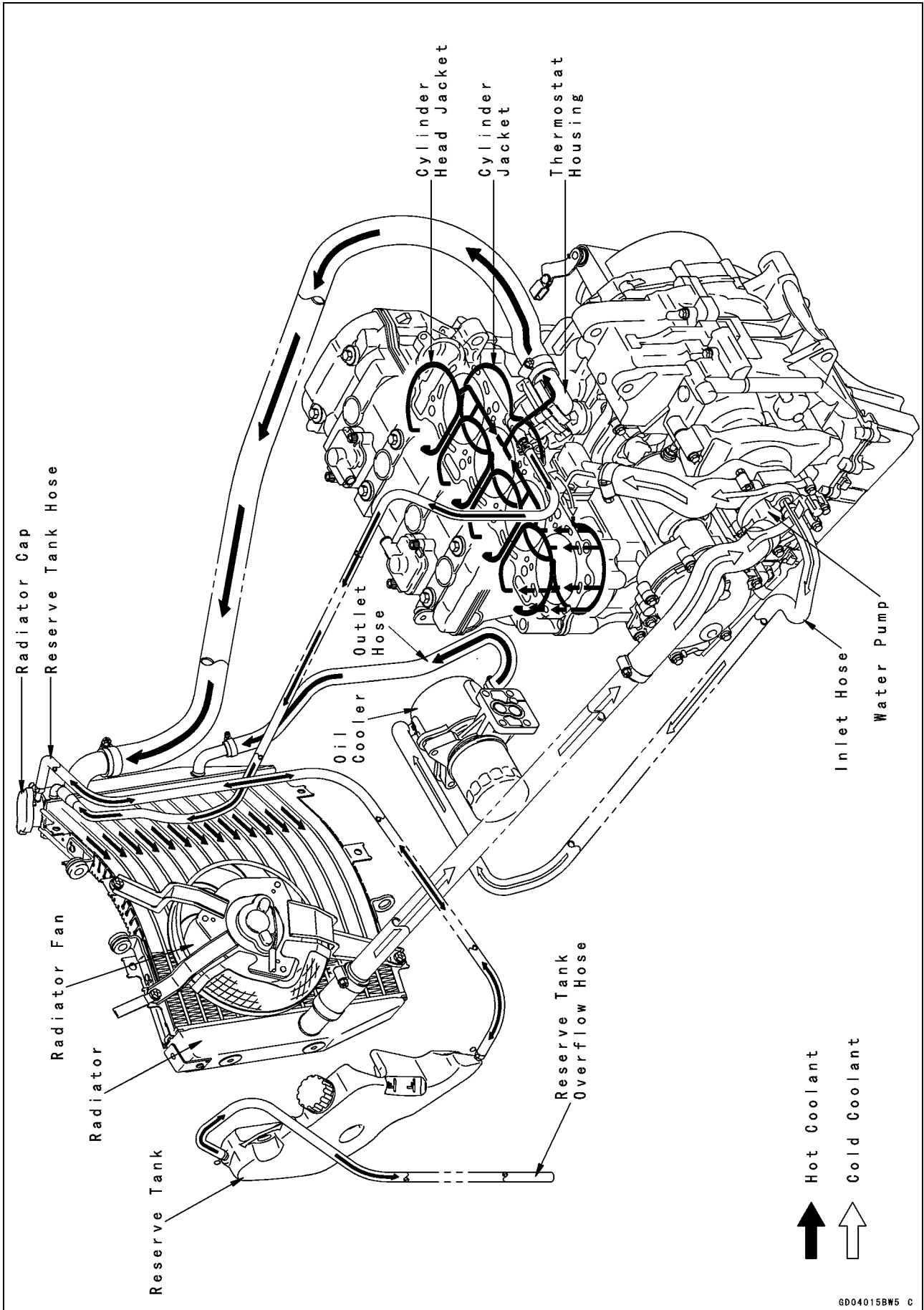



---

**Coolant Flow Chart**

---

Permanent type antifreeze is used as a coolant to protect the cooling system from rust and corrosion. When the engine starts, the water pump turns and the coolant circulates.

The thermostat is a wax pellet type which opens or closes with coolant temperature changes. The thermostat continuously changes its valve opening to keep the coolant temperature at the proper level. When coolant temperature is less than 55°C (131°F), the thermostat closes so that the coolant flow is restricted through the air bleeder hole, causing the engine to warm up more quickly. When coolant temperature is more than 58 ~ 62°C (136 ~ 144°F), the thermostat opens and the coolant flows.

When the coolant temperature goes up beyond 95°C (203°F), the radiator fan relay conducts to operate the radiator fan. The radiator fan draws air through the radiator core when there is not sufficient air flow such as at low speeds. This increases up the cooling action of the radiator. When the coolant temperature is below 90°C (194°F), the fan relay opens and the radiator fan stops.

In this way, this system controls the engine temperature within narrow limits where the engine operates most efficiently even if the engine load varies.

The system is pressurized by the radiator cap to suppress boiling and the resultant air bubbles which can cause engine overheating. As the engine warms up, the coolant in the radiator and the water jacket expands. The excess coolant flows through the radiator cap and hose to the reserve tank to be stored there temporarily. Conversely, as the engine cools down, the coolant in the radiator and the water jacket contracts, and the stored coolant flows back to the radiator from the reserve tank.

The radiator cap has two valves. One is a pressure valve which holds the pressure in the system when the engine is running. When the pressure exceeds 112 ~ 142 kPa (1.15 ~ 1.45 kgf/cm<sup>2</sup>, 16 ~ 21 psi), the pressure valve opens and releases the pressure to the reserve tank. As soon as pressure escapes, the valve closes, and keeps the pressure at 112 ~ 142 kPa (1.15 ~ 1.45 kgf/cm<sup>2</sup>, 16 ~ 21 psi). When the engine cools down, another small valve (vacuum valve) in the cap opens. As the coolant cools, the coolant contracts to form a vacuum in the system. The vacuum valve opens and allows the coolant from the reserve tank to enter the radiator.

## 4-6 COOLING SYSTEM

### Specifications

Item	Standard
<b>Coolant Provided when Shipping</b> Type (Recommended)  Color Mixed Ratio Freezing Point Total Amount	Permanent type of antifreeze (soft water and ethylene glycol plus corrosion and rust inhibitor chemicals for aluminum engines and radiators)  Green Soft water 50%, coolant 50% – 35°C (– 31°F) 2.5 L (2.6 US qt) (Reserve tank full level, including radiator and engine)
<b>Radiator Cap</b> Relief Pressure	112 ~ 142 kPa (1.15 ~ 1.45 kgf/cm <sup>2</sup> , 16 ~ 21 psi)
<b>Thermostat</b> Valve Opening Temperature Valve Full Opening Lift	58 ~ 62°C (136 ~ 144°F) 8 mm (0.31 in.) or more @75°C (167°F)

## Coolant

### *Coolant Deterioration Inspection*

- Visually inspect the coolant in the reserve tank.
- ★ If whitish cotton-like wafts are observed, aluminum parts in the cooling system are corroded. If the coolant is brown, iron or steel parts are rusting. In either case, flush the cooling system.
- ★ If the coolant gives off an abnormal smell, check for a cooling system leak. It may be caused by exhaust gas leaking into the cooling system.

### *Coolant Level Inspection*

- Refer to the Coolant Level Inspection in the Periodic Maintenance chapter.

### *Coolant Draining*

- Refer to the Coolant Change in the Periodic Maintenance chapter.

### *Coolant Filling*

- Refer to the Coolant Change in the Periodic Maintenance chapter.

### *Pressure Testing*

- Remove the upper fairing (see Frame chapter).
- Remove the radiator cap, and install the cooling system pressure tester [A] on the filler neck.

#### NOTE

- *Wet the cap sealing surfaces with water or coolant to prevent pressure leaks.*
- Build up pressure in the system carefully until the pressure reaches 142 kPa (1.45 kgf/cm<sup>2</sup>, 21 psi).

#### CAUTION

**During pressure testing, do not exceed the pressure for which the system is designed. The maximum pressure is 142 kPa (1.45 kgf/cm<sup>2</sup>, 21 psi).**

- Watch the gauge for at least 6 seconds.
- ★ If the pressure holds steady, the system is all right.
- ★ If the pressure drops and no external source is found, check for internal leaks. Droplets in the engine oil indicate internal leakage. Check the cylinder head gasket and the water pump.
- Remove the pressure tester, replenish the coolant, and install the radiator cap.

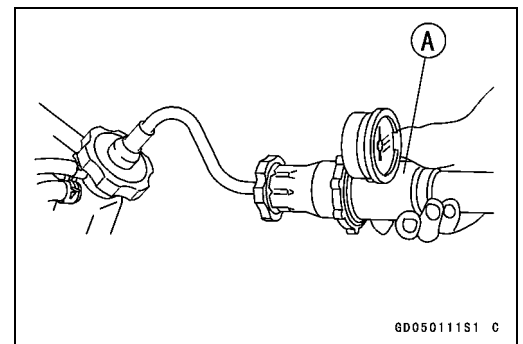

## 4-8 COOLING SYSTEM

---

### Coolant

---

#### *Cooling System Flushing*

Over a period of time, the cooling system accumulates rust, scale, and lime in the water jacket and radiator. When this accumulation is suspected or observed, flush the cooling system. If this accumulation is not removed, it will clog up the water passage and considerably reduce the efficiency of the cooling system.

- Drain the cooling system (see Coolant Change in the Periodic Maintenance chapter).
- Fill the cooling system with fresh water mixed with a flushing compound.

CAUTION
<b>Do not use a flushing compound which is harmful to the aluminum engine and radiator. Carefully follow the instructions supplied by the manufacturer of the cleaning product.</b>

- Warm up the engine, and run it at normal operating temperature for about ten minutes.
- Stop the engine, and drain the cooling system.
- Fill the system with fresh water.
- Warm up the engine and drain the system.
- Repeat the previous two steps once more.
- Fill the system with a permanent type coolant and bleed the air from the system (see Coolant Change in the Periodic Maintenance chapter).

#### *Coolant Reserve Tank Removal/Installation*

- The coolant reserve tank is removed and installed during coolant change (see Coolant Change in the Periodic Maintenance chapter).

## Water Pump

### Water Pump Removal

- Drain:
  - Coolant (see Coolant Change in the Periodic Maintenance chapter)
  - Engine Oil (see Engine Oil Change in the Periodic Maintenance chapter)
- Remove:
  - Water Hoses [A]

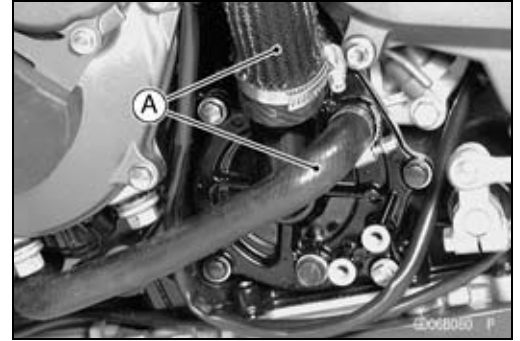

- Remove:
  - Water Pump Cover Bolts [A]
  - Water Pump Cover [B]

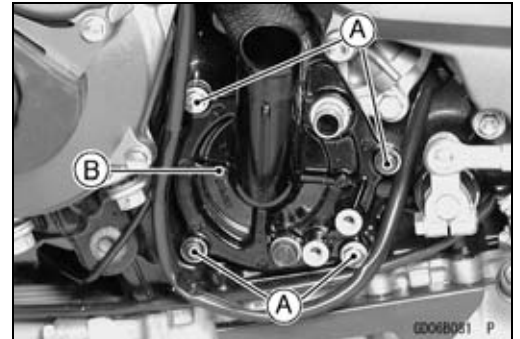

- Remove the water hose [A].
- Remove the water pump body [B] with impeller [C].



### Water Pump Installation

- Turn the pump drive gear shaft so that the slot [A] in its shaft fits onto the projection [B] of the impeller shaft.

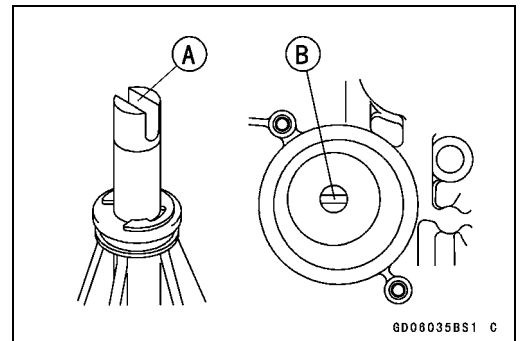

- Install the water hose [A] as shown.



## 4-10 COOLING SYSTEM

### Water Pump

- Install the water pump cover [A].
- Tighten:  
Torque - Water Pump Cover Bolts: 9.8 N·m (1.0 kgf·m, 87 in·lb)
- Install the water hoses [B] as shown.

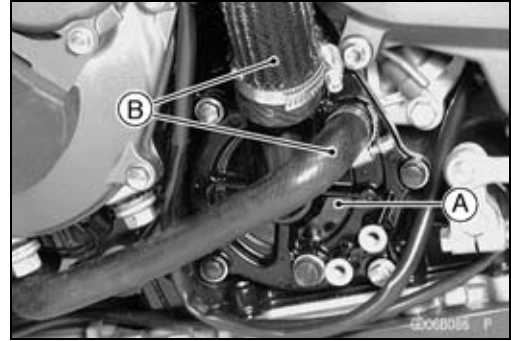

#### *Water Pump Impeller Inspection*

- Visually inspect the water pump impeller [A].
- ★ If the surface is corroded or if the blades are damaged, replace the water pump assy.



## Radiator

### Radiator and Radiator Fan Removal

- Remove:
  - Upper Fairing (see Frame chapter)
  - Coolant (Drain, see Coolant Change in the Periodic Maintenance chapter)
  - Radiator Hoses [A]

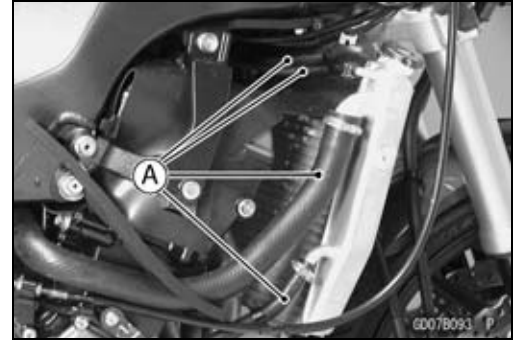

- Remove:
  - Radiator Upper Bolt [A]



- Remove:
  - Radiator Lower Bolt [A]
  - Radiator Fan Lead Connector [B]
  - Radiator Hose [C]
- Pull the radiator from the projection [D], and remove the radiator.

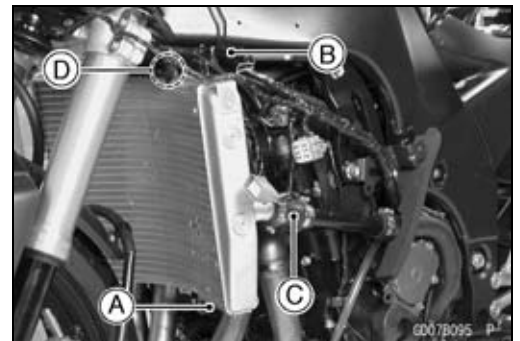

**CAUTION**

**Do not touch the radiator core. This could damage the radiator fins, resulting in loss of cooling efficiency.**

- Remove:
  - Radiator Fan Mounting Bolts [A]
  - Radiator Fan [B]

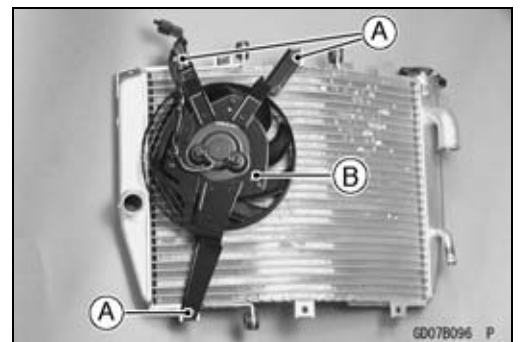

## 4-12 COOLING SYSTEM

### Radiator

#### Radiator and Radiator Fan Installation

- Install the radiator in the projection [A] as shown.

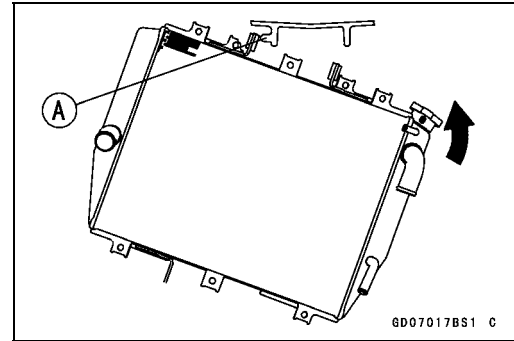

- Install the radiator bracket collar [A] as shown.  
Rubber Damper [B]  
Radiator [C]
- Tighten:  
Torque - Radiator Lower Bolt [D]: 7.0 N·m (0.70 kgf·m, 61 in·lb)  
Radiator Upper Bolt [E]: 7.0 N·m (0.70 kgf·m, 61 in·lb)

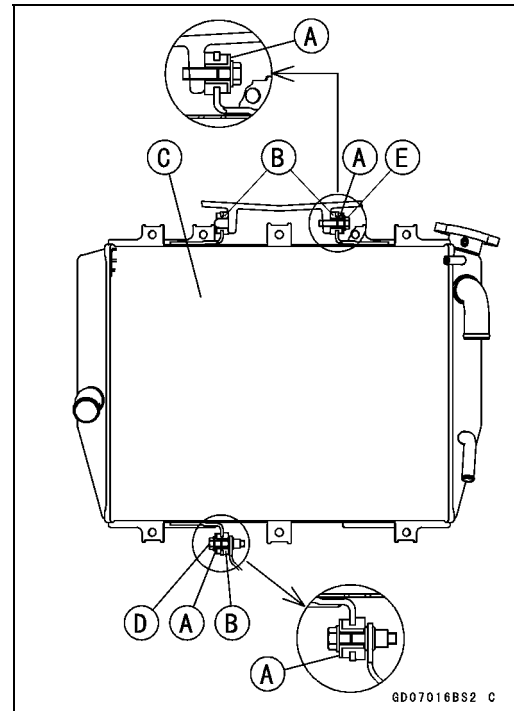

- Cover the heat insulation rubber plate [A] on the radiator.
- Through the radiator fan lead [B] in the heat insulation rubber plate hole, and clamp the radiator fan lead with the radiator clamp.

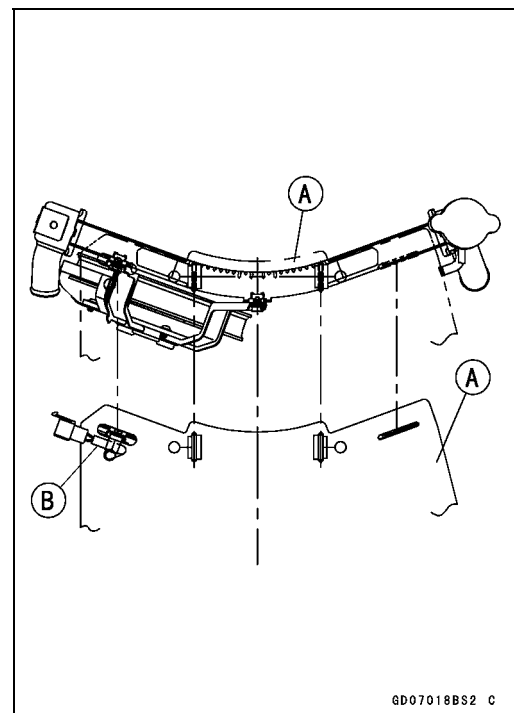



## Radiator

### Radiator Inspection

- Check the radiator core.
- ★ If there are obstructions to air flow, remove them.
- ★ If the corrugated fins [A] are deformed, carefully straighten them.
- ★ If the air passages of the radiator core are blocked more than 20% by unremovable obstructions or irreparably deformed fins, replace the radiator with a new one.

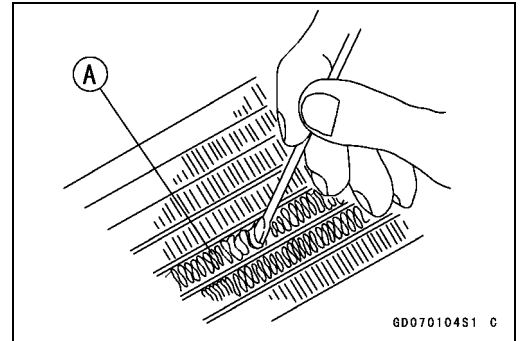

### CAUTION

**When cleaning the radiator with steam cleaner, be careful of the following to prevent radiator damage:**  
**Keep the steam gun [A] away more than 0.5 m (1.6 ft) [B] from the radiator core.**  
**Hold the steam gun perpendicular [C] (not oblique [D]) to the core surface.**  
**Run the steam gun, following the core fin direction.**

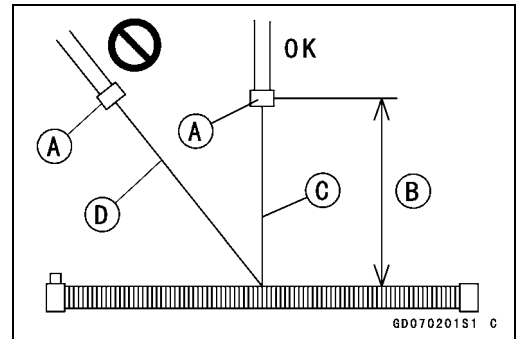

### Radiator Cap Inspection

- Remove:
  - Upper Fairing (see Frame chapter)
  - Radiator Cap
- Check the condition of the bottom [A] and top [B] valve seals and valve spring [C].
- ★ If any one of them shows visible damage, replace the cap with a new one.

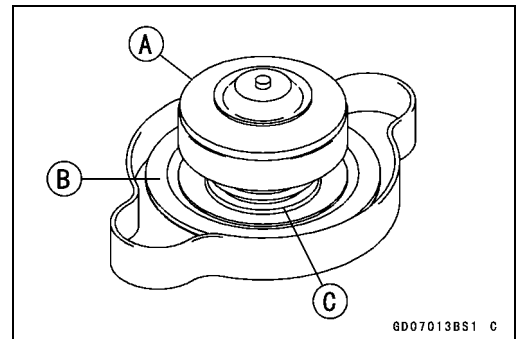

- Install the cap [A] on a cooling system pressure tester [B].

### NOTE

○ Wet the cap sealing surfaces with water or coolant to prevent pressure leaks.

- Watching the pressure gauge, pump the pressure tester to build up the pressure until the relief valve opens: the gauge needle flicks downward. Stop pumping and measure leak time at once. The relief valve must open within the specified range in the table below and the gauge hand must remain within the same range at least 6 seconds.

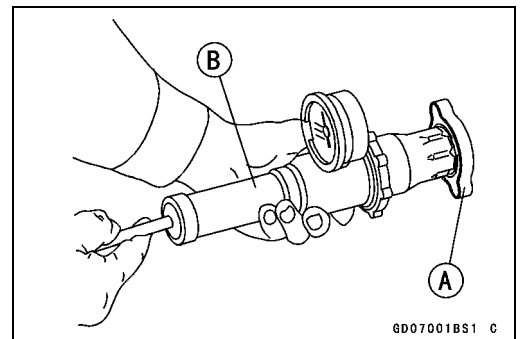

### Radiator Cap Relief Pressure

**Standard: 112 ~ 142 kPa (1.15 ~ 1.45 kgf/cm<sup>2</sup>, 16 ~ 21 psi)**

- ★ If the cap can not hold the specified pressure or if it holds too much pressure, replace it with a new one.

## 4-14 COOLING SYSTEM

---

### Radiator

---

#### *Radiator Filler Neck Inspection*

- Remove the upper fairing (see Frame chapter).
- Remove the radiator cap.
- Check the radiator filler neck for signs of damage.
- Check the condition of the top and bottom sealing seats [A] in the filler neck. They must be smooth and clean for the radiator cap to function properly.



## Thermostat

### Thermostat Removal

- Drain the coolant (see Coolant Change in the Periodic Maintenance chapter).
- Remove:
  - Fuel Tank (see Fuel System (DFI) chapter)
  - Air Cleaner Housing (see Fuel System (DFI) chapter)
  - Throttle Body Assy (see Fuel System (DFI) chapter)
  - Thermostat Housing Mounting Bolts [A]
  - Water Hoses [B]
  
- Remove:
  - Thermostat Housing Cover Bolts [A]
  - Thermostat Housing Cover [B]
  - Thermostat

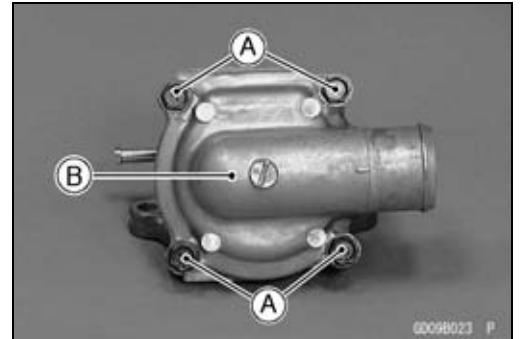
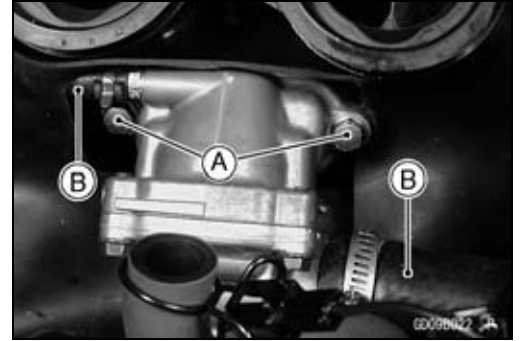

### Thermostat Installation

- Install the thermostat [A] in the housing so that the air bleeder hole [B] is on top.
  - Install a new O-ring into the housing.
  - Tighten the thermostat housing cover bolts.
- Torque - Thermostat Housing Cover Bolts: 6.0 N·m (0.61 kgf·m, 53 in·lb)**
- Fill the radiator with coolant (see Coolant Change in the Periodic Maintenance chapter).

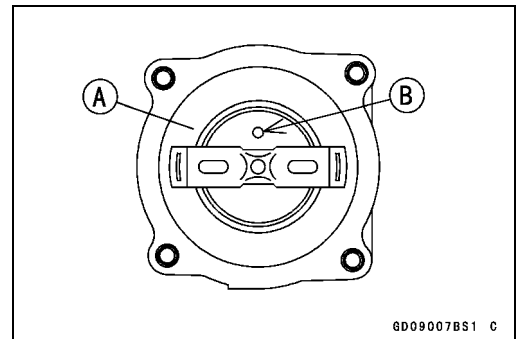

### Thermostat Inspection

- Remove the thermostat, and inspect the thermostat valve [A] at room temperature.
- ★ If the valve is open, replace the thermostat with a new one.

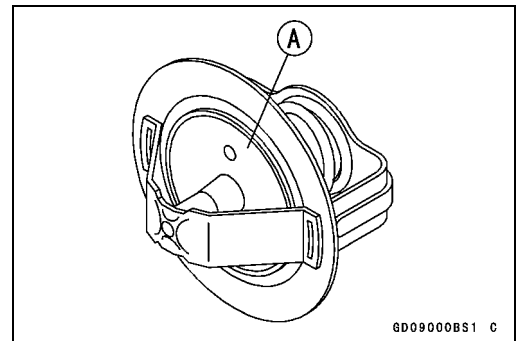

## 4-16 COOLING SYSTEM

### Thermostat

- To check valve opening temperature, suspend the thermostat [A] in a container of water and raise the temperature of the water.
- The thermostat must be completely submerged and must not touch the container sides or bottom. Suspend an accurate thermometer [B] in the water so that the heat sensitive portions [C] are located in almost the same depth.
- ★ If the measurement is out of the specified range, replace the thermostat with a new one.

#### Thermostat Valve Opening Temperature

58 ~ 62°C (136 ~ 144°F)

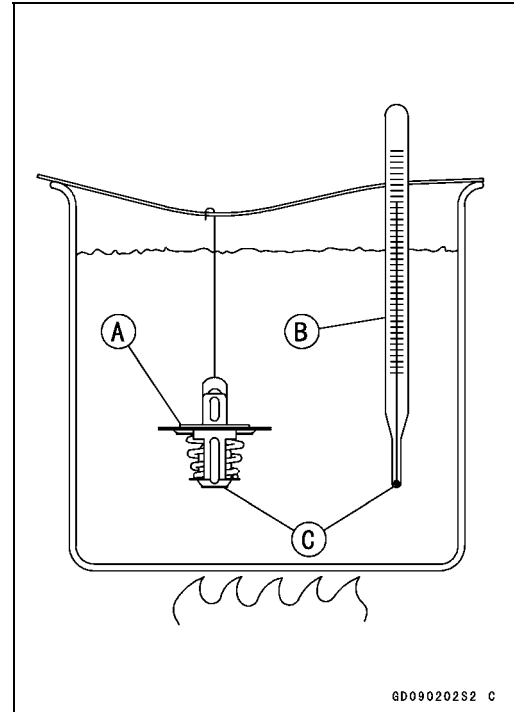

## Hoses and Pipes

### *Hose Installation*

- Install the hoses and pipes, being careful to follow bending direction. Avoid sharp bending, kinking, flattening or twisting.
- Run the hoses in accordance with the Cable, Wire, and Hose Routing section in the Appendix chapter.
- Install the clamp [A] as near as possible to the hose end to clear the raised rib of the fitting. This will prevent the hoses from working loose.
- The clamp screws should be positioned correctly to prevent the clamps from contacting the other parts.

**Torque - Water Hose Clamp Screws: 2.0 N·m (0.20 kgf·m, 17 in·lb)**

### *Hose Inspection*

- Refer to the Radiator Hose and Connection Inspection in the Periodic Maintenance chapter.

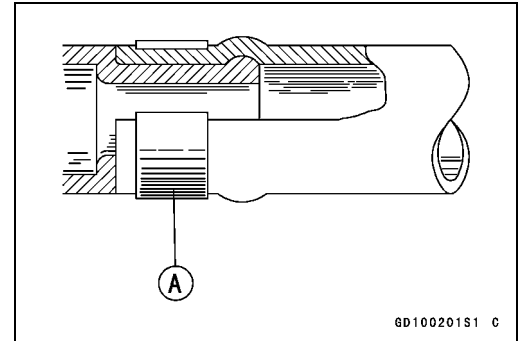

## 4-18 COOLING SYSTEM

### Water Temperature Sensor

#### CAUTION

The water temperature sensor should never be allowed to fall on a hard surface. Such a shock to their parts can damage them.

#### *Water Temperature Sensor Removal*

- Refer to the Water Temperature Sensor Removal in the Fuel System (DFI) chapter.  
Water Temperature Sensor [A]



#### *Water Temperature Sensor Inspection*

- Refer to the Water Temperature Sensor Inspection in the Electrical System chapter.

# Engine Top End

## Table of Contents

Exploded View.....	5-2	Camshaft Chain Installation.....	5-17
Specifications.....	5-6	Cylinder Head.....	5-18
Special Tools.....	5-7	Cylinder Compression	
Clean Air System.....	5-9	Measurement.....	5-18
Air Suction Valve Removal.....	5-9	Cylinder Head Removal.....	5-19
Air Suction Valve Installation.....	5-9	Cylinder Head Installation.....	5-19
Air Suction Valve Inspection.....	5-9	Cylinder Head Warp.....	5-20
Air Switching Valve Removal.....	5-9	Valves.....	5-21
Air Switching Valve Installation.....	5-9	Valve Clearance Inspection.....	5-21
Air Switching Valve Operation		Valve Removal.....	5-21
Test.....	5-9	Valve Installation.....	5-21
Air Switching Valve Unit Test.....	5-9	Valve Guide Removal.....	5-21
Clean Air System Hose		Valve Guide Installation.....	5-22
Inspection.....	5-10	Valve-to-Guide Clearance	
Cylinder Head Cover.....	5-11	Measurement (Wobble	
Cylinder Head Cover Removal.....	5-11	Method).....	5-22
Cylinder Head Cover Installation.....	5-11	Valve Seat Inspection.....	5-23
Camshaft Chain Tensioner.....	5-13	Valve Seat Repair.....	5-23
Camshaft Chain Tensioner		Throttle Body Holder.....	5-28
Removal.....	5-13	Throttle Body Holder Installation..	5-28
Camshaft Chain Tensioner		Muffler.....	5-29
Installation.....	5-13	Muffler Body Removal/Installation	5-29
Camshaft, Camshaft Chain.....	5-14	Exhaust Pipe Removal.....	5-29
Camshaft Removal.....	5-14	Exhaust Pipe Installation.....	5-31
Camshaft Installation.....	5-14	Exhaust Butterfly Valve Cable	
Camshaft, Camshaft Cap Wear... ..	5-15	Removal.....	5-33
Camshaft Runout.....	5-16	Exhaust Butterfly Valve Cable	
Cam Wear.....	5-16	Installation.....	5-35
Camshaft Chain Removal.....	5-17		

# 5-2 ENGINE TOP END

## Exploded View

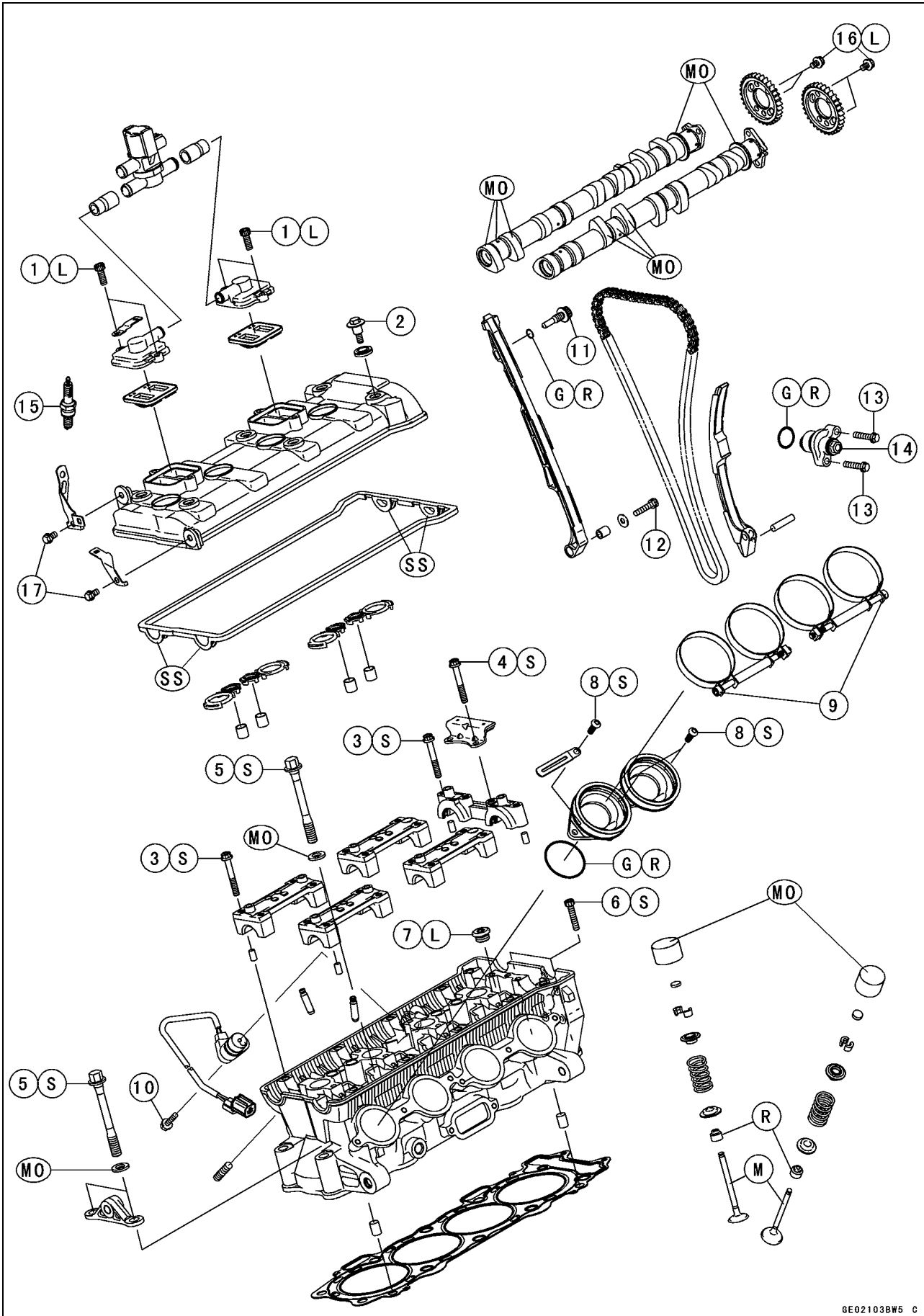



**Exploded View**

No.	Fastener	Torque			Remarks
		N·m	kgf·m	ft·lb	
1	Air Suction Valve Cover Bolts	9.8	1.0	87 in·lb	L
2	Cylinder Head Cover Bolts	9.8	1.0	87 in·lb	
3	Camshaft Cap Bolts	12	1.2	104 in·lb	S
4	Camshaft Chain Guide Bolts	12	1.2	104 in·lb	S
5	Cylinder Head Bolts (M10 New Bolts)	59	6.0	44	MO, S
5	Cylinder Head Bolts (M10 Used Bolts)	57	5.8	42	MO, S
6	Cylinder Head Bolts (M6)	12	1.2	104 in·lb	S
7	Water Passage Plugs	20	2.0	15	L
8	Throttle Body Holder Bolts	9.8	1.0	87 in·lb	S
9	Throttle Body Assy Holder Clamp Bolts	2.0	0.20	17 in·lb	
10	Camshaft Position Sensor Bolt	9.8	1.0	87 in·lb	
11	Front Camshaft Chain Guide Bolt (Upper)	25	2.5	18	
12	Front Camshaft Chain Guide Bolt (Lower)	12	1.2	104 in·lb	
13	Camshaft Chain Tensioner Mounting Bolts	9.8	1.0	87 in·lb	
14	Camshaft Chain Tensioner Cap Bolt	20	2.0	15	
15	Spark Plugs	13	1.3	113 in·lb	
16	Cam Sprocket Mounting Bolts	15	1.5	11	L
17	Bracket Mounting Bolts	9.8	1.0	87 in·lb	

EO: Apply engine oil.

G: Apply grease.

L: Apply a non-permanent locking agent.

M: Apply molybdenum disulfide grease.

MO: Apply molybdenum disulfide oil.

(mixture of the engine oil and molybdenum disulfide grease in a weight ratio 10 : 1)

R: Replacement Parts

S: Follow the specific tightening sequence.

SS: Apply silicone sealant (Kawasaki Bond: 56019-120).

# 5-4 ENGINE TOP END

## Exploded View

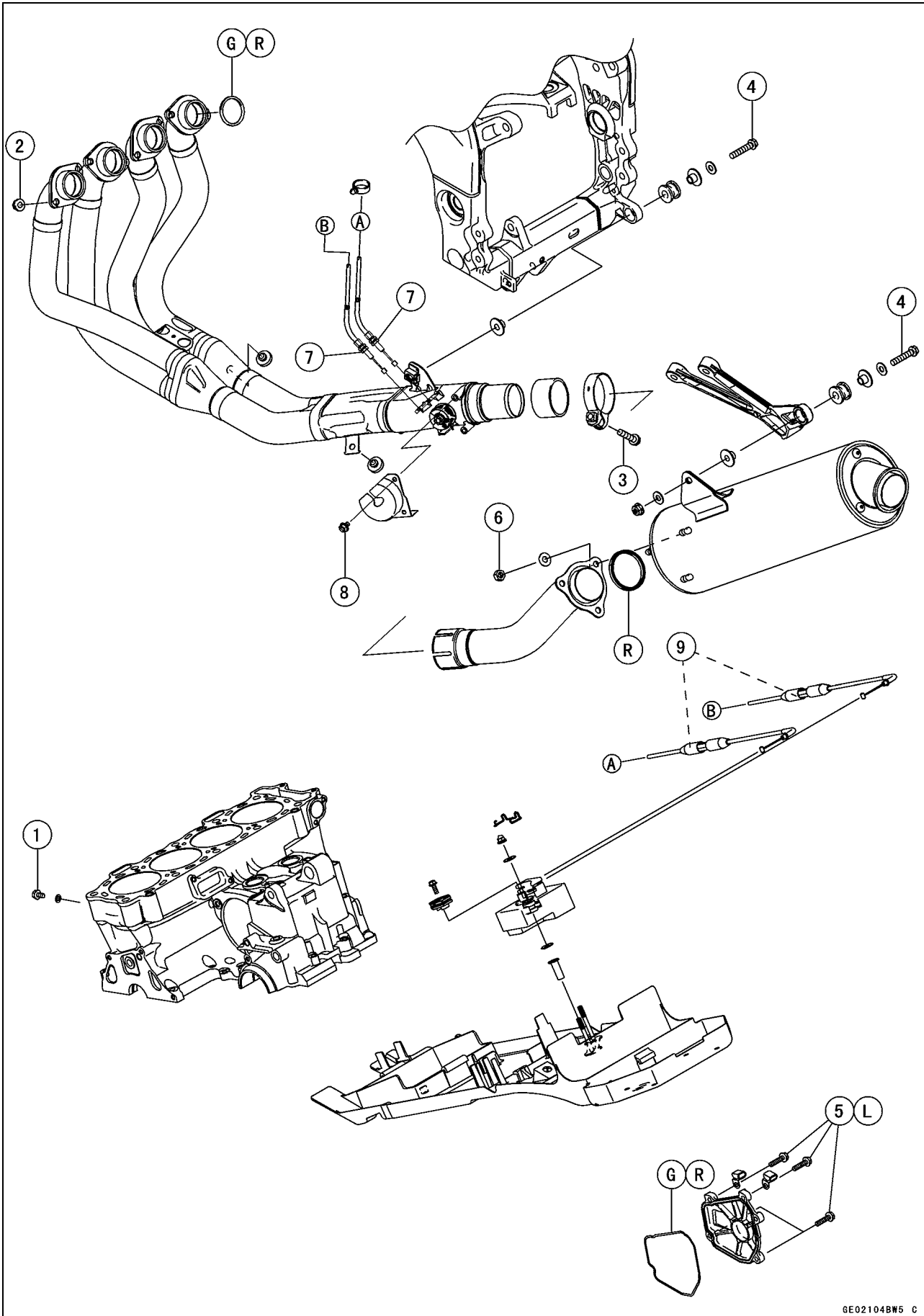

**Exploded View**

No.	Fastener	Torque			Remarks
		N·m	kgf·m	ft·lb	
1	Coolant Drain Plug (Cylinder)	9.8	1.0	87 in·lb	
2	Exhaust Pipe Manifold Holder Nuts	17	1.7	12	
3	Muffler Body Clamp Bolt	17	1.7	12	
4	Muffler Body Mounting Bolts	25	2.5	18	
5	Crankshaft Sensor Cover Bolts	9.8	1.0	87 in·lb	L
6	Muffler Body Assembly Nuts	22	2.2	16	
7	Exhaust Butterfly Valve Cable Locknuts	7.0	0.71	62 in·lb	
8	Exhaust Butterfly Valve Cover Bolts	8.8	0.90	78 in·lb	
9	Exhaust Butterfly Valve Cable Adjuster Locknuts	7.0	0.71	62 in·lb	

G: Apply grease.  
 L: Apply a non-permanent locking agent.  
 R: Replacement Parts

**Exhaust System**

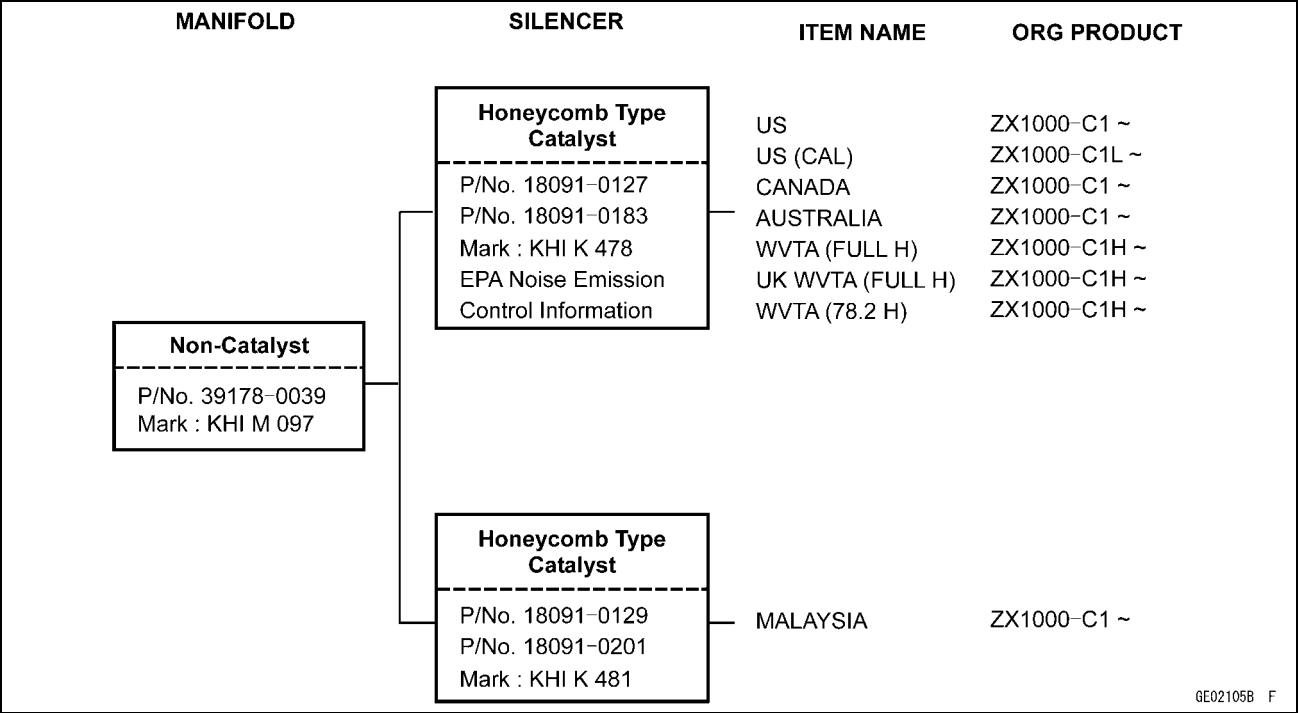

GE02105B F

78.2: Horsepower 78.2 kW (106.3 ps)  
 Full: Full Power  
 H: Honeycomb Type Catalyst

CAL: California Model  
 UK: United Kingdom Model  
 US: United States Model

## 5-6 ENGINE TOP END

### Specifications

Item	Standard	Service Limit
<b>Camshafts</b>		
Cam Height:		
Exhaust	34.942 ~ 35.058 mm (1.3757 ~ 1.3802 in.)	34.84 mm (1.372 in.)
Inlet	35.342 ~ 35.458 mm (1.3914 ~ 1.3960 in.)	35.24 mm (1.387 in.)
Camshaft Journal, Camshaft Cap Clearance	0.038 ~ 0.081 mm (0.0015 ~ 0.0032 in.)	0.17 mm (0.0067 in.)
Camshaft Journal Diameter	23.940 ~ 23.962 mm (0.9425 ~ 0.9434 in.)	23.91 mm (0.941 in.)
Camshaft Bearing Inside Diameter	24.000 ~ 24.021 mm (0.9449 ~ 0.9457 in.)	24.08 mm (0.948 in.)
Camshaft Runout	TIR 0.02 mm (0.0008 in.) or less	TIR 0.1 mm (0.004 in.)
<b>Cylinder Head</b>		
Cylinder Compression	(Usable Range) 1 100 ~ 1 670 kPa (11.2 ~ 17.0 kgf/cm <sup>2</sup> , 159 ~ 242 psi) @320 r/min (rpm)	— — —
Cylinder Head Warp	— — —	0.05 mm (0.002 in.)
<b>Valves</b>		
Valve Clearance:		
Exhaust	0.17 ~ 0.22 mm (0.0067 ~ 0.0087 in.)	— — —
Inlet	0.15 ~ 0.24 mm (0.0059 ~ 0.0094 in.)	— — —
Valve Head Thickness:		
Exhaust	0.8 mm (0.031 in.)	0.4 mm (0.016 in.)
Inlet	0.5 mm (0.020 in.)	0.25 mm (0.001 in.)
Valve Stem Bend	TIR 0.01 mm (0.0004 in.) or less	TIR 0.05 mm (0.002 in.)
Valve Stem Diameter:		
Exhaust	4.470 ~ 4.485 mm (0.1760 ~ 0.1766 in.)	4.46 mm (0.176 in.)
Inlet	4.475 ~ 4.490 mm (0.1762 ~ 0.1768 in.)	4.46 mm (0.176 in.)
Valve Guide Inside Diameter:		
Exhaust	4.500 ~ 4.512 mm (0.1772 ~ 0.1776 in.)	4.58 mm (0.180 in.)
Inlet	4.500 ~ 4.512 mm (0.1772 ~ 0.1776 in.)	4.58 mm (0.180 in.)
Valve/valve Guide Clearance (Wobble Method):		
Exhaust	0.05 ~ 0.13 mm (0.0020 ~ 0.0051 in.)	0.36 mm (0.014 in.)
Inlet	0.03 ~ 0.11 mm (0.0012 ~ 0.0043 in.)	0.36 mm (0.014 in.)
Valve Seat Cutting Angle	45°, 32°, 60°	— — —
Valve Seating Surface:		
Width:		
Exhaust	0.8 ~ 1.2 mm (0.031 ~ 0.047 in.)	— — —
Inlet	0.5 ~ 1.0 mm (0.020 ~ 0.039 in.)	— — —
Outside Diameter:		
Exhaust	24.9 ~ 25.1 mm (0.980 ~ 0.988 in.)	— — —
Inlet	30.4 ~ 30.6 mm (1.197 ~ 1.205 in.)	— — —
Valve Spring Free Length:		
Exhaust	44.78 mm (1.763 in.)	42.9 mm (1.689 in.)
Inlet	39.15 mm (1.541 in.)	37.5 mm (1.476 in.)

Special Tools

Compression Gauge, 20 kgf/cm<sup>2</sup>:  
57001-221

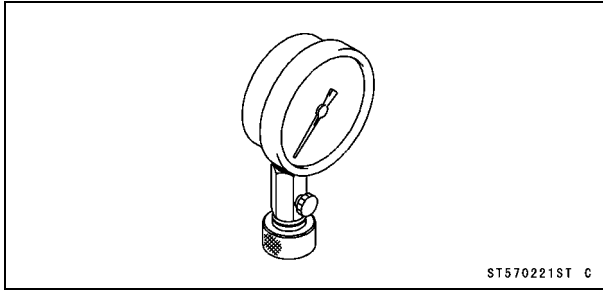

Valve Seat Cutter Holder Bar:  
57001-1128

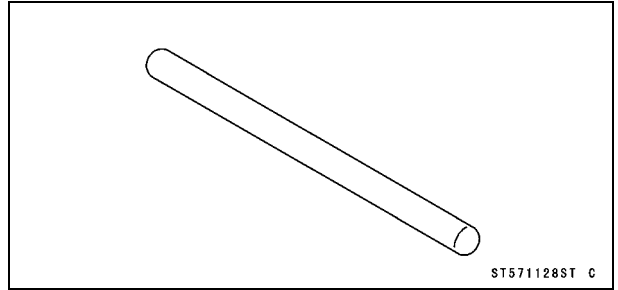

Valve Spring Compressor Assembly:  
57001-241

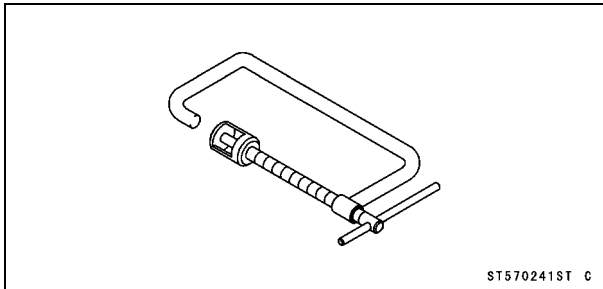

Valve Seat Cutter, 32° -  $\phi$ 33:  
57001-1199

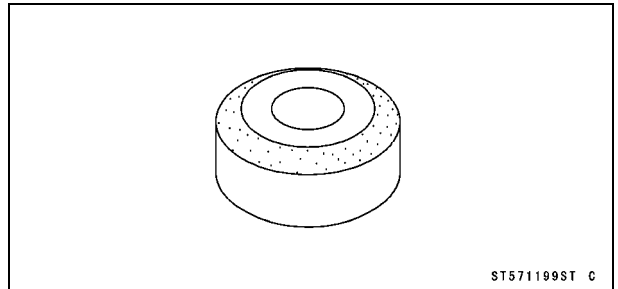

Valve Seat Cutter, 45° -  $\phi$ 27.5:  
57001-1114

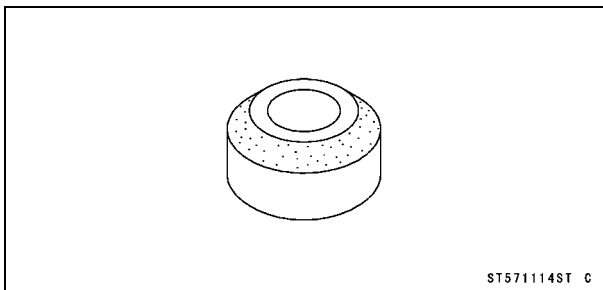

Fork Oil Level Gauge:  
57001-1290

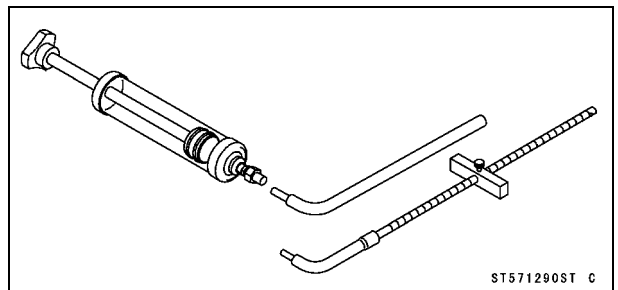

Valve Seat Cutter, 45° -  $\phi$ 32:  
57001-1115

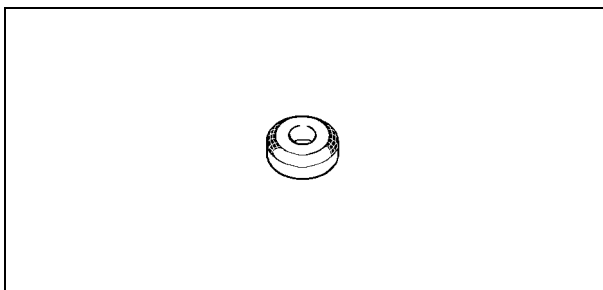

Valve Seat Cutter, 60° -  $\phi$ 25:  
57001-1328

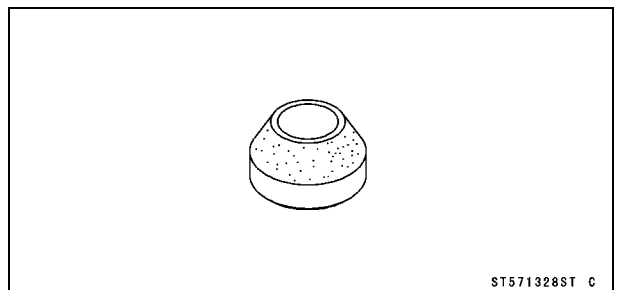

Valve Seat Cutter, 32° -  $\phi$ 28:  
57001-1119

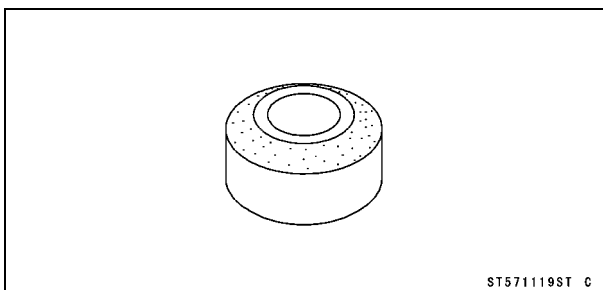

Valve Seat Cutter Holder,  $\phi$ 4.5:  
57001-1330

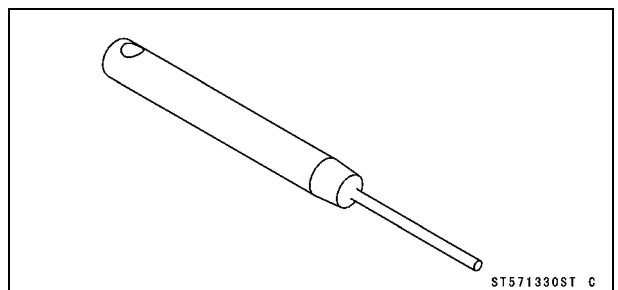

# 5-8 ENGINE TOP END

## Special Tools

**Valve Guide Arbor,  $\phi 4.5$ :**  
57001-1331

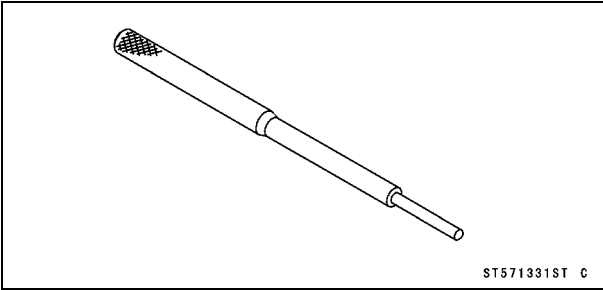

**Valve Spring Compressor Adapter,  $\phi 24$ :**  
57001-1586

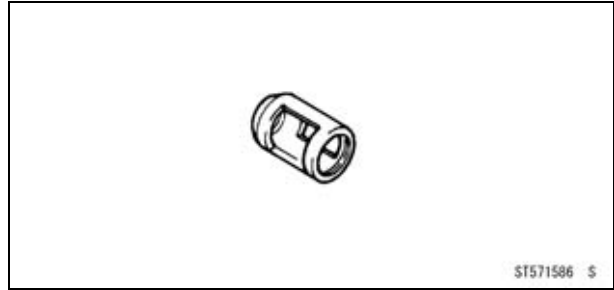

**Valve Guide Reamer,  $\phi 4.5$ :**  
57001-1333

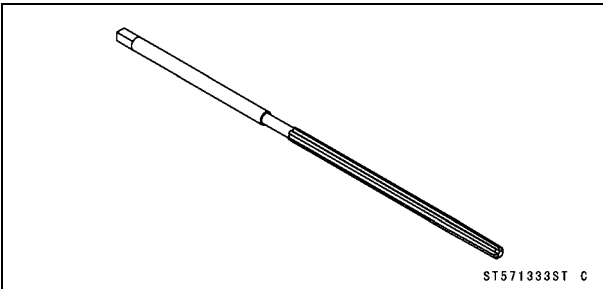

**Compression Gauge Adapter, M10  $\times$  1.0:**  
57001-1601

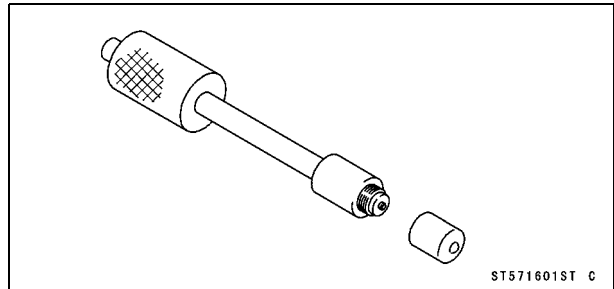

**Valve Seat Cutter, 60° -  $\phi 33$ :**  
57001-1334

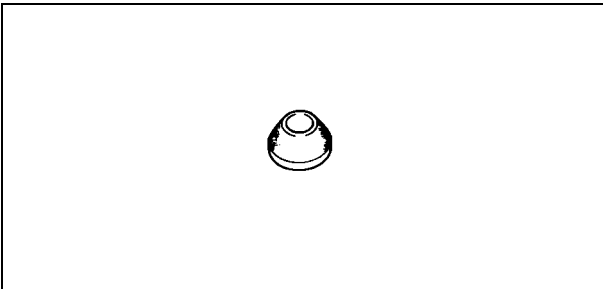

**L-Shape Hose:**  
57001-1606

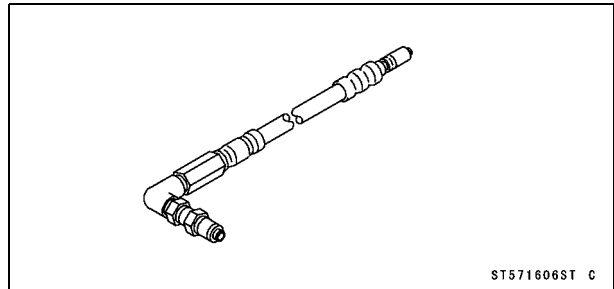

**Valve Guide Driver:**  
57001-1564

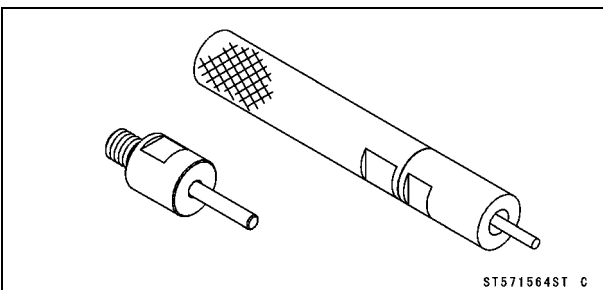

**Washer:**  
57001-1612

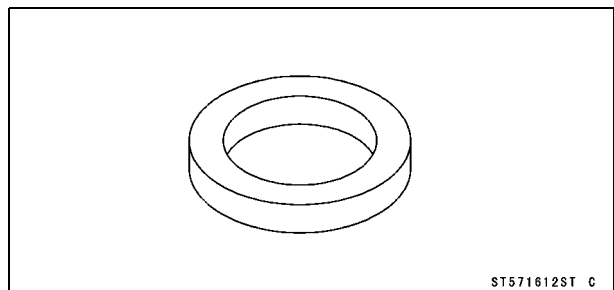

## Clean Air System

### *Air Suction Valve Removal*

- Remove:
  - Fuel Tank (see Fuel System (DFI) chapter)
  - Air Cleaner Housing (see Fuel System (DFI) chapter)
- Separate the hoses [A] from the air suction valve cover.
- Remove:
  - Air Suction Valve Cover Bolts [B]
  - Air Suction Valve Cover [C]
  - Air Suction Valve

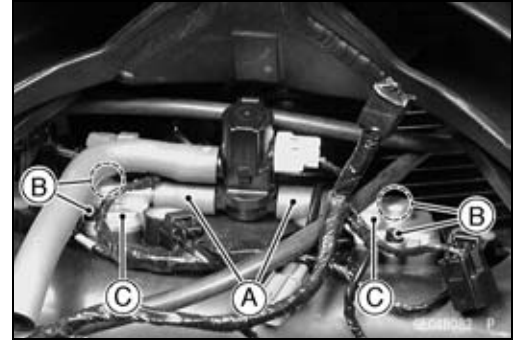

### *Air Suction Valve Installation*

- Install the air suction valve so that opening [A] of the reed faces the rear and downward.
- Apply a non-permanent locking agent to the threads of the air suction valve cover bolts, and tighten them with the specified torque.

**Torque - Air Suction Valve Cover Bolts: 9.8 N·m (1.0 kgf·m, 87 in·lb)**

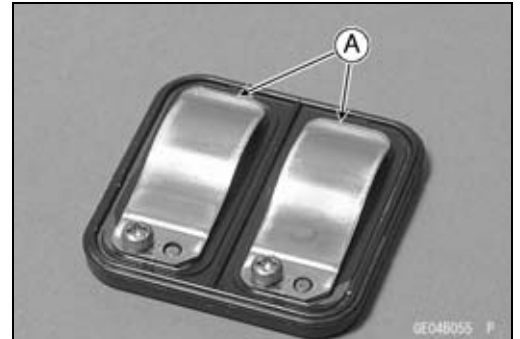

### *Air Suction Valve Inspection*

- Refer to the Air Suction Valve Inspection in the Periodic Maintenance chapter.

### *Air Switching Valve Removal*

- Remove:
  - Fuel Tank (see Fuel System (DFI) chapter)
  - Air Cleaner Housing (see Fuel System (DFI) chapter)
  - Connector [A]
  - Air Switching Valve [B]

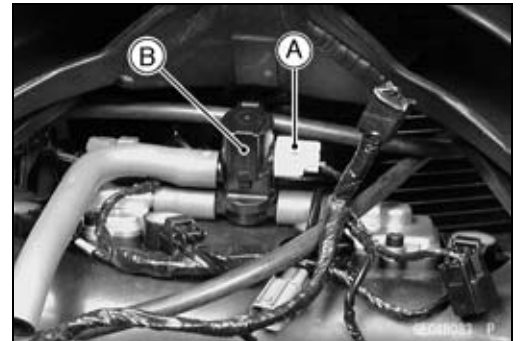

### *Air Switching Valve Installation*

- Install the air switching valve so that the air duct [A] faces left side.
- Route the hoses correctly (see Appendix chapter).



### *Air Switching Valve Operation Test*

- Refer to the Air Switching Valve Operation Test in the Electrical System chapter.

### *Air Switching Valve Unit Test*

- Refer to the Air Switching Valve Unit Test in the Electrical System chapter.

## 5-10 ENGINE TOP END

---

### Clean Air System

---

#### *Clean Air System Hose Inspection*

- Be certain that all the hoses are routed without being flattened or kinked, and are connected correctly to the air cleaner housing, air switching valve and air suction valve covers.
- ★ If they are not, correct them. Replace them if they are damaged.



## Cylinder Head Cover

### Cylinder Head Cover Removal

- Remove:
  - Upper Fairing (see Frame chapter)
  - Fuel Tank (see Fuel System (DFI) chapter)
  - Air Cleaner Housing (see Fuel System (DFI) chapter)
  - Throttle Body Assembly (see Fuel System (DFI) chapter)
  - Air Switching Valve [A] (see Air Switching Valve Removal)
- Remove the radiator temporary, free the heat insulation rubber plate.

#### NOTE

○Do not remove water hoses.

- Remove the bracket [A].
- Remove:
  - Stick Coils (see Electrical System chapter)
  - Air Suction Valve Covers
- Remove the cylinder head cover bolts [A].
- Remove the cylinder head cover to backward floating it a little up.

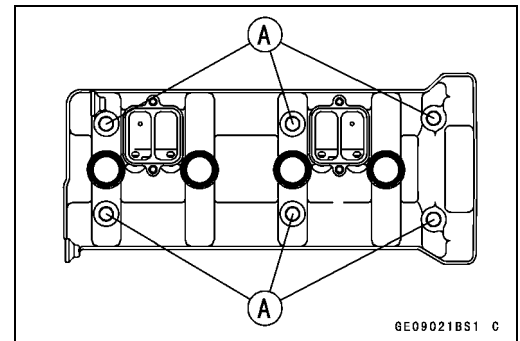
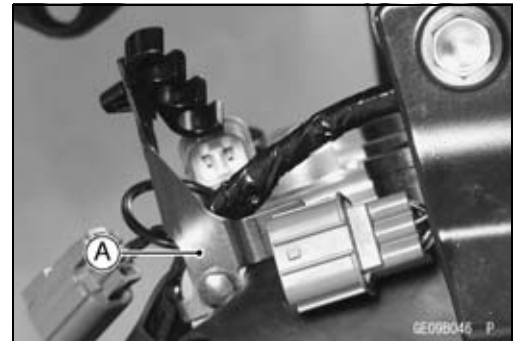
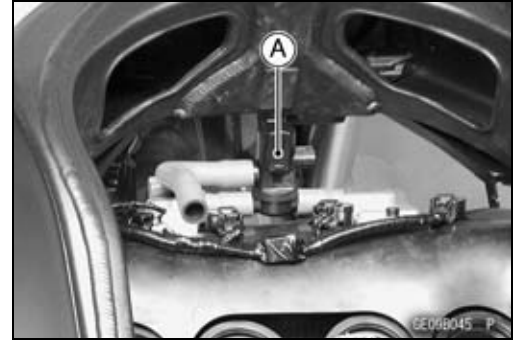

6E09021BS1 C

### Cylinder Head Cover Installation

- Replace the head cover gasket with a new one.
- Apply silicone sealant [A] to the cylinder head as shown.
  - Sealant - Three Bond (Silicone Sealant): TB1211F**

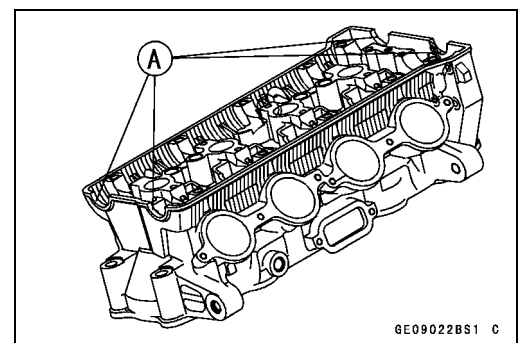

6E09022BS1 C

## 5-12 ENGINE TOP END

### Cylinder Head Cover

- Install:

- Dowel Pins [A]
- Plug Hole Gaskets [B]

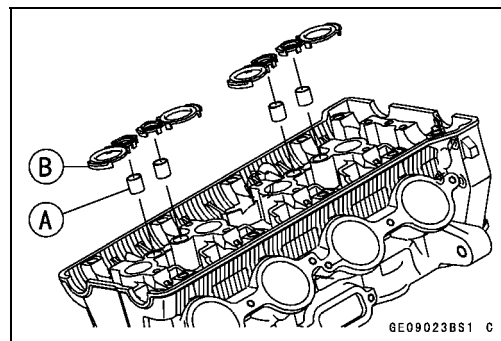

- Install the washer [A] with the metal side faces upward.
- Tighten the cover bolts.  
Torque - Cylinder Head Cover Bolts [B]: 9.8 N·m (1.0 kgf·m, 87 in·lb)
- Install the removed parts (see appropriate chapters).

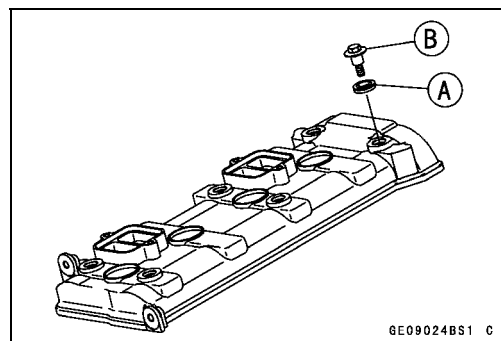

## Camshaft Chain Tensioner

### Camshaft Chain Tensioner Removal

#### CAUTION

This is a non-return type camshaft chain tensioner. The push rod does not return to its original position once it moves out to take up camshaft chain slack. Observe all the rules listed below:

When removing the tensioner, do not take out the mounting bolts only halfway. Retightening the mounting bolts from this position could damage the tensioner and the camshaft chain. Once the bolts are loosened, the tensioner must be removed and reset as described in "Camshaft Chain Tensioner Installation."

Do not turn over the crankshaft while the tensioner is removed. This could upset the camshaft chain timing, and damage the valves.

- Remove:
  - Right Middle Fairing (see Frame chapter)
  - Cap Bolt [A]
  - Washer [B]
  - Spring [C]
  - Rod [D]
- Remove the mounting bolts [E] and take off the camshaft chain tensioner.

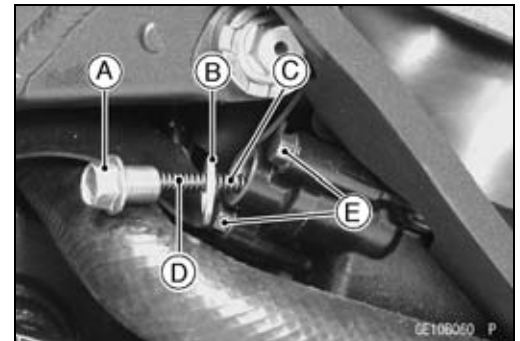

### Camshaft Chain Tensioner Installation

- Release the stopper [A] and push the push rod [B] into the interior of tensioner body [C].
- Install the tensioner body so that the stopper faces upward.

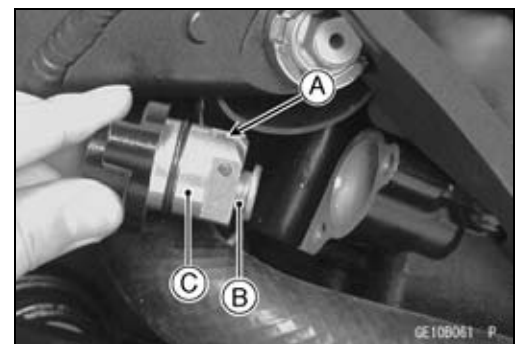

- Tighten the tensioner mounting bolts [A].
  - Torque - Camshaft Chain Tensioner Mounting Bolts: 9.8 N·m (1.0 kgf·m, 87 in·lb)**
- Install the rod, spring and washer.
- Tighten the cap bolt [B].
  - Torque - Camshaft Chain Tensioner Cap Bolt: 20 N·m (2.0 kgf·m, 15 ft·lb)**
- Turn the crankshaft 2 turns clockwise to allow the tensioner to expand and recheck the camshaft chain timing.

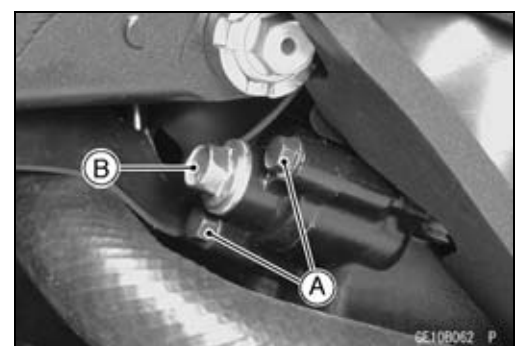

## 5-14 ENGINE TOP END

### Camshaft, Camshaft Chain

#### Camshaft Removal

- Remove:
  - Cylinder Head Cover (see Cylinder Head Cover Removal)
  - Crankshaft Sensor Cover
- Position the crankshaft at #1, 4 piston TDC.
  - TDC mark [A] for #1, 4 Pistons
  - Timing Mark (crankcase halves mating surface) [B]

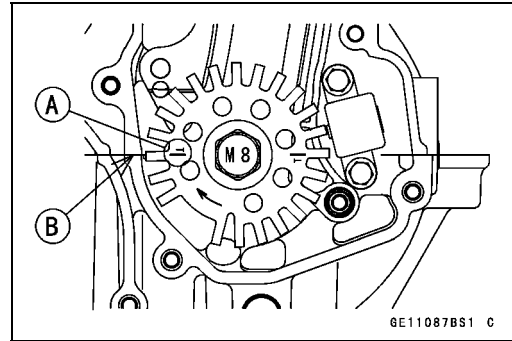

- Remove:
  - Camshaft Chain Tensioner (see Camshaft Chain Tensioner Removal)
  - Camshaft Cap Bolts [A]
  - Chain Guide
  - Camshaft Caps [B]
  - Camshafts [C]
- Stuff a clean cloth into the chain tunnel to keep any parts from dropping into the crankcase.

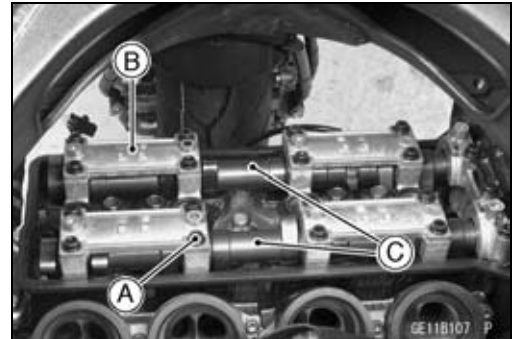

- Remove the cam sprocket mounting bolts [A].
- Remove the cam sprocket.

#### CAUTION

The crankshaft may be turned while the camshafts are removed. Always pull the chain taut while turning the crankshaft. This avoids kinking the chain on the lower (crankshaft) sprocket. A kinked chain could damage both the chain and the sprocket.

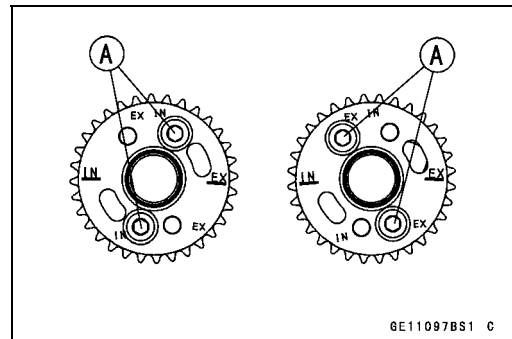

#### Camshaft Installation

- Be sure to install the following parts.
  - Plug Hole Gaskets [A]
  - Dowel Pins [B]

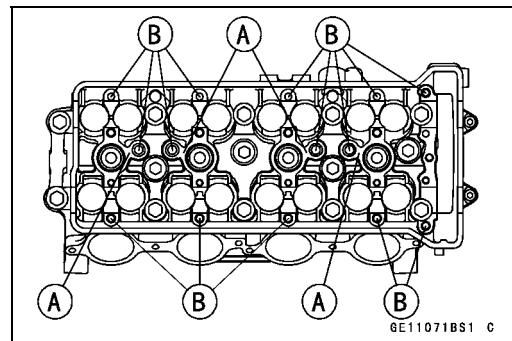

- Install the cam sprockets as shown in figure.
  - #4 Cam Positions [A]
  - Inlet Cam Sprocket [B]
  - Exhaust Cam Sprocket [C]
- Apply a non-permanent locking agent to the threads and tighten the bolts.

**Torque - Cam Sprocket Mounting Bolts: 15 N·m (1.5 kgf·m, 11 ft·lb)**

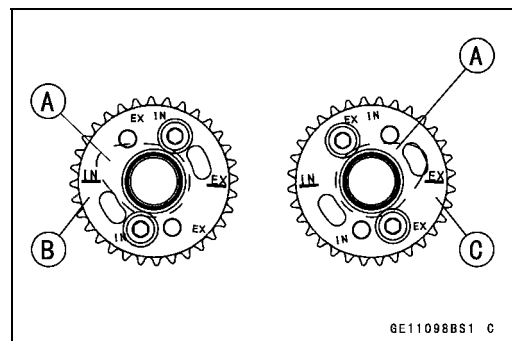

**Camshaft, Camshaft Chain**

- Apply engine oil to all cam parts and journals.
- If a new camshaft is to be used, apply a thin coat of molybdenum disulfide grease to the cam surfaces.

**NOTE**

○ The exhaust camshaft has a 1001 EX mark [A] and the inlet camshaft has a 1001 IN mark [B]. Be careful not to mix up these shafts.

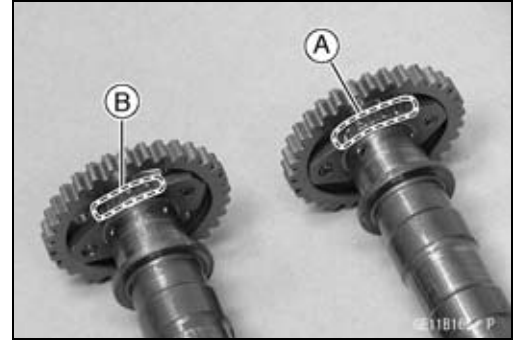

- Position the crankshaft at #1, 4 piston TDC.
- Pull the tension side (exhaust side) [A] of the chain taut to install the chain.
- Engage the camshaft chain with the camshaft sprockets so that the timing marks on the sprockets are positioned as shown.
- The timing marks of #1, 4T must be aligned with the lower surface of crankcase of rear side [B].
- The timing marks must be aligned with the cylinder head upper surface [C].  
EX mark [D]  
IN mark [E]
- Before installing the camshaft cap and chain guide, install the camshaft chain tensioner body temporarily.

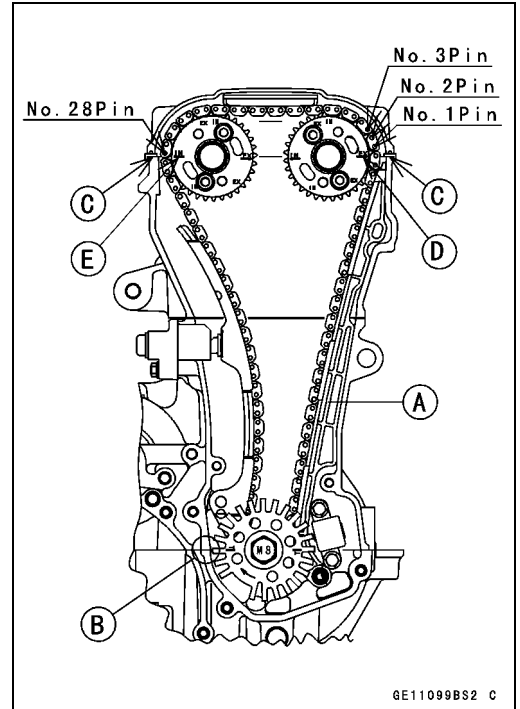

- Install the camshaft cap and chain guide [A].
- First tighten the camshaft cap and all chain guide bolts evenly to seat the camshaft in place, then tighten all bolts following the specified tightening sequence.

**Torque - Camshaft Cap Bolts (1 ~ 16, 17, 18): 12 N·m (1.2 kgf·m, 104 in·lb)**

**Camshaft Chain Guide Bolts (19, 20): 12 N·m (1.2 kgf·m, 104 in·lb)**

- Install the camshaft chain tensioner (see Camshaft Chain Tensioner Installation).

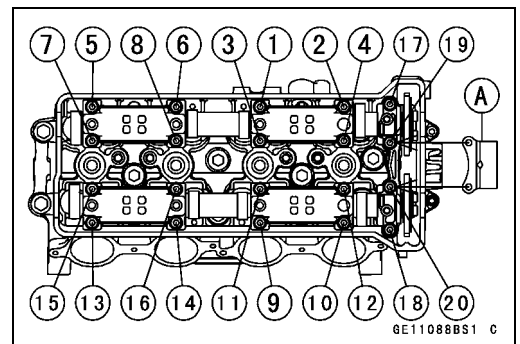

**Camshaft, Camshaft Cap Wear**

- Remove:  
Camshaft Chain Guide  
Camshaft Cap (see Camshaft Removal)
- Cut strips of plastigage to journal width. Place a strip on each journal parallel to the camshaft installed in the correct position.
- Measure each clearance between the camshaft journal and the camshaft cap using plastigage (press gauge) [A].

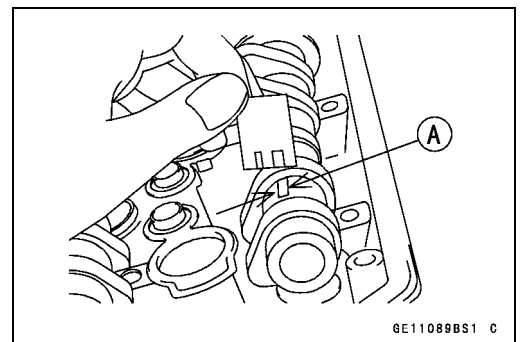

## 5-16 ENGINE TOP END

### Camshaft, Camshaft Chain

- Tighten:

**Torque - Camshaft Cap Bolts: 12 N·m (1.2 kgf·m, 104 in·lb)**

**Camshaft Chain Guide Bolts: 12 N·m (1.2 kgf·m, 104 in·lb) (see Camshaft Installation)**

#### NOTE

○ Do not turn the camshaft when the plastigage is between the journal and camshaft cap.

#### Camshaft Journal, Camshaft Cap Clearance

**Standard: 0.038 ~ 0.081 mm (0.0015 ~ 0.0032 in.)**

**Service Limit: 0.17 mm (0.0067 in.)**

★ If any clearance exceeds the service limit, measure the diameter of each camshaft journal with a micrometer.

#### Camshaft Journal Diameter

**Standard: 23.940 ~ 23.962 mm (0.9425 ~ 0.9434 in.)**

**Service Limit: 23.91 mm (0.941 in.)**

★ If the camshaft journal diameter is less than the service limit, replace the camshaft with a new one and measure the clearance again.

★ If the clearance still remains out of the limit, replace the cylinder head unit.

#### Camshaft Runout

- Remove the camshaft (see Camshaft Removal).
- Set the camshaft in a camshaft alignment jig or on V blocks.
- Measure runout with a dial gauge at the specified place as shown.
- ★ If the runout exceeds the service limit, replace the shaft.

#### Camshaft Runout

**Standard: TIR 0.02 mm (0.0008 in.) or less**

**Service Limit: TIR 0.1 mm (0.004 in.)**

#### Cam Wear

- Remove the camshaft (see Camshaft Removal).
- Measure the height [A] of each cam with a micrometer.
- ★ If the cams are worn down past the service limit, replace the camshaft.

#### Cam Height

**Standard:**

**Exhaust 34.942 ~ 35.058 mm (1.3757 ~ 1.3802 in.)**

**Inlet 35.342 ~ 35.458 mm (1.3914 ~ 1.3960 in.)**

**Service Limit:**

**Exhaust 34.84 mm (1.372 in.)**

**Inlet 35.24 mm (1.387 in.)**

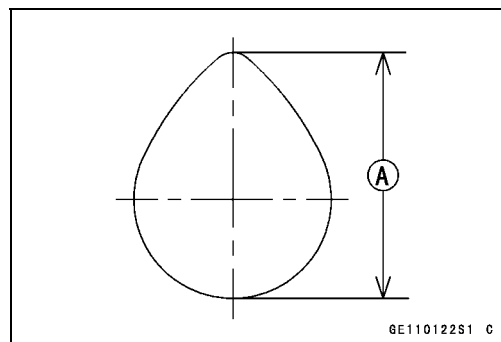
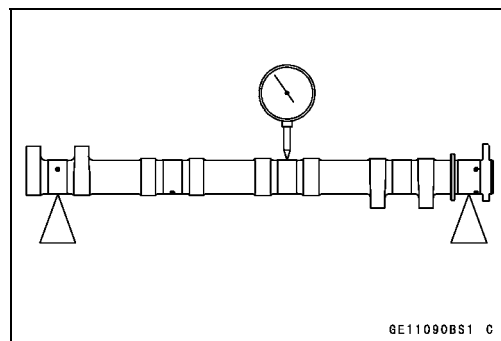

## Camshaft, Camshaft Chain

### Camshaft Chain Removal

- Remove:
  - Camshafts (see Camshaft Removal)
  - Timing Rotor (see Electrical System chapter)
  - Crankshaft Sensor [A] (see Electrical System chapter)
  - Lower Front Camshaft Chain Guide Bolt [B]

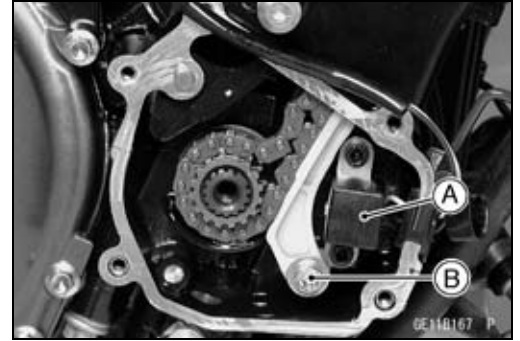

- Remove the upper front camshaft chain guide bolt [A].

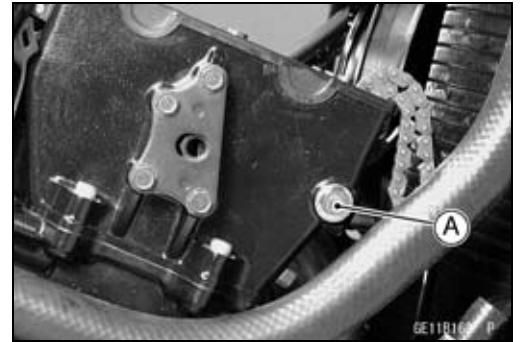

- Remove the crankshaft sprocket [A].
- Pull out the camshaft chain [B] from downward.

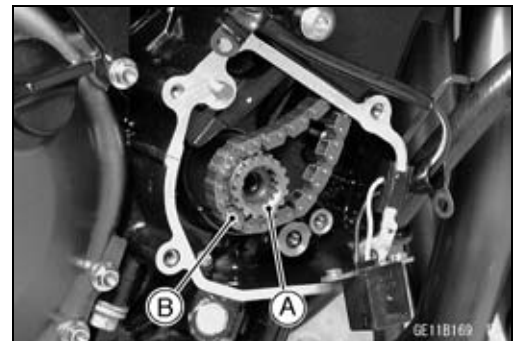

### Camshaft Chain Installation

- Install the camshaft chain from head side.
- Install the crankshaft sprocket [A] on the crankshaft [B] with their teeth [C] aligned.
- Install the front camshaft chain guide, and tighten the bolts.

**Torque - Front Camshaft Chain Guide Bolt (Upper): 25 N·m  
(2.5 kgf·m, 18 ft·lb)**

**Front Camshaft Chain Guide Bolt (Lower): 12 N·m  
(1.2 kgf·m, 104 in·lb)**

- Install the removed parts (see appropriate chapters).

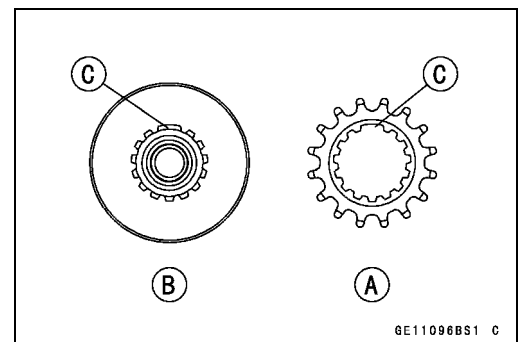

## 5-18 ENGINE TOP END

### Cylinder Head

#### Cylinder Compression Measurement

##### NOTE

○ Use the battery which is fully charged.

- Warm up the engine thoroughly.
- Stop the engine.
- Remove:
  - Fuel Tank (see Fuel System (DFI) chapter)
  - Air Cleaner Housing (see Fuel System (DFI) chapter)
  - Stick Coils (see Electrical System chapter)
  - Spark Plugs (see Electrical System chapter)

**Owner's Tool - Spark Plug Wrench: 92110-1132**

- Attach the compression gauge [A] and adapter [B] firmly into the spark plug hole.
- Using the starter motor, turn the engine over with the throttle fully open until the compression gauge stops rising; the compression is the highest reading obtainable.

**Special Tools - Compression Gauge, 20 kgf/cm<sup>2</sup>: 57001-221**  
**Compression Gauge Adapter, M10 × 1.0: 57001-1601**  
**L-Shape Hose: 57001-1606**

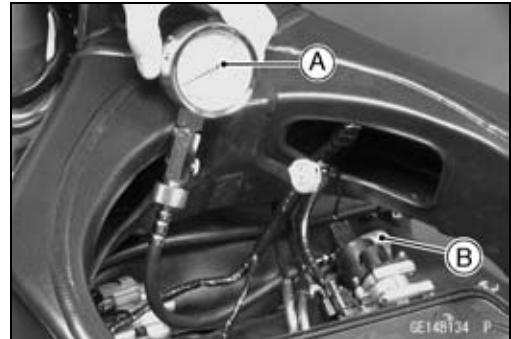

#### Cylinder Compression

**Usable Range: 1 100 ~ 1 670 kPa (11.2 ~ 17.0 kgf/cm<sup>2</sup>, 159 ~ 242 psi) @ 20 r/min (rpm)**

- Repeat the measurement for the other cylinders.
- Install the spark plugs.

**Torque - Spark Plugs: 13 N·m (1.3 kgf·m, 113 in·lb)**

The following table should be consulted if the obtainable compression reading is not within the usable range.

Problem	Diagnosis	Remedy (Action)
Cylinder compression is higher than usable range	Carbon accumulation on piston and in combustion chamber possibly due to damaged valve stem oil seal and/or damaged piston oil rings (This may be indicated by white exhaust smoke).	Remove the carbon deposits and replace damaged parts if necessary.
	Incorrect cylinder head gasket thickness	Replace the gasket with a standard part.
Cylinder compression is lower than usable range	Gas leakage around cylinder head	Replace damaged check gasket and cylinder head warp.
	Bad condition of valve seating	Repair if necessary.
	Incorrect valve clearance	Adjust the valve clearance.
	Incorrect piston/cylinder clearance	Replace the piston and/or cylinder.
	Piston seizure	Inspect the cylinder and replace/repair the cylinder and/or piston as necessary.
	Bad condition of piston ring and/or piston ring grooves	Replace the piston and/or the piston rings.



## Cylinder Head

### Cylinder Head Removal

- Drain the coolant (see Coolant Change in the Periodic Maintenance chapter).
- Remove:
  - Fuel Tank (see Fuel System (DFI) chapter)
  - Air Cleaner Housing (see Fuel System (DFI) chapter)
  - Throttle Body Assembly (see Fuel System (DFI) chapter)
  - Exhaust Pipe (see Exhaust Pipe Removal)
  - Cylinder Head Cover (see Cylinder Head Cover Removal)
  - Camshaft Position Sensor (see Electrical System chapter)
  - Camshafts (see Camshaft Removal)
  - Front Camshaft Chain Guide
- Remove the M6 cylinder head bolts [B], and then the M10 cylinder head bolts [A].
- Take off the cylinder head.

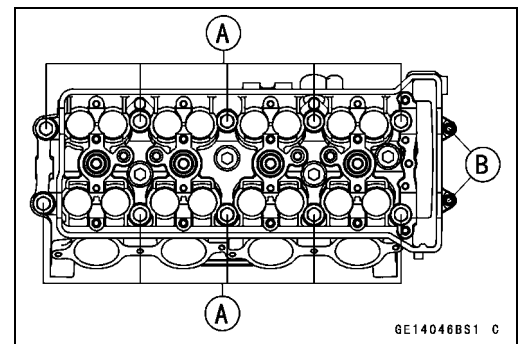

### Cylinder Head Installation

#### NOTE

○The camshaft cap is machined with the cylinder head, so if a new cylinder head is installed, use the cap that is supplied with the new head.

- Install a new cylinder head gasket and dowel pins.
- Apply molybdenum disulfide oil solution to both sides [A] of the cylinder head bolt washers [B] and the thread of head bolts [C].
- Tighten the M10 cylinder head bolts following the tightening sequence [1 ~ 10].

#### Torque - Cylinder Head Bolts (M10):

First: 20 N·m (2.0 kgf·m, 15 ft·lb)

Final (New Bolts): 59 N·m (6.0 kgf·m, 44 ft·lb)

Final (Used Bolts): 57 N·m (5.8 kgf·m, 42 ft·lb)

- Tighten the M6 cylinder head bolts [11 ~ 12].

Torque - Cylinder Head Bolts (M6): 12 N·m (1.2 kgf·m, 104 in·lb)

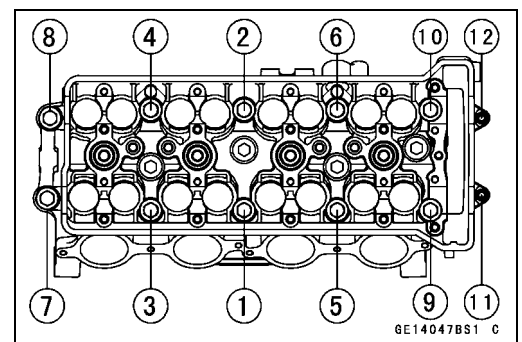
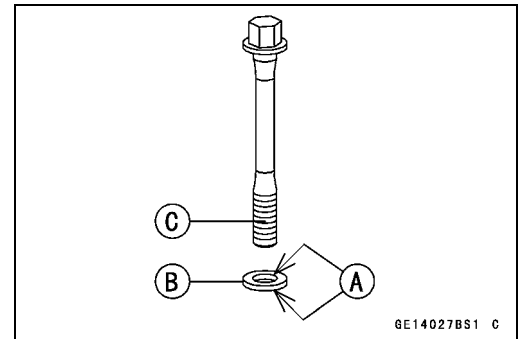

## 5-20 ENGINE TOP END

### Cylinder Head

- Install:
  - Front Camshaft Chain Guide [A]
  - O-ring [B]
  - Collar [C]
  - Washer [D]
- Tighten:
  - Torque - Front Camshaft Chain Guide Bolt (Upper) [E]: 25 N·m (2.5 kgf·m, 18 ft·lb)**
  - Front Camshaft Chain Guide Bolt (Lower) [F]: 12 N·m (1.2 kgf·m, 104 in·lb)**
- Install the removed parts (see appropriate chapters).

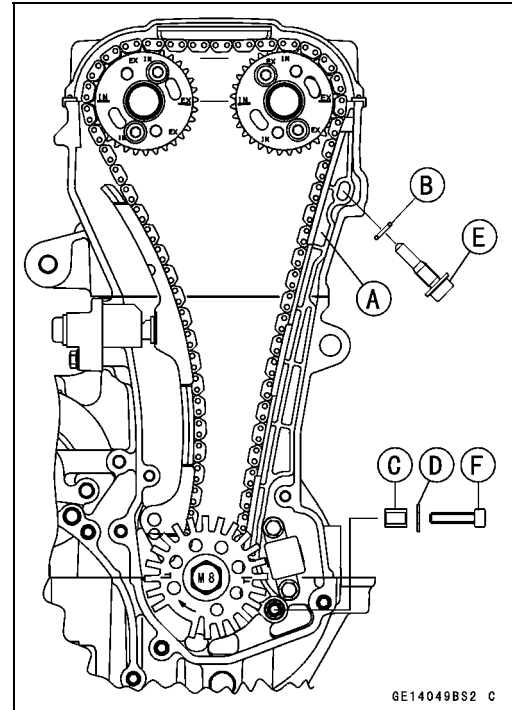

#### Cylinder Head Warp

- Clean the cylinder head.
- Lay a straightedge across the lower surface of the cylinder head at several positions.
- Use a thickness gauge [A] to measure the space between the straightedge [B] and the head.

#### Cylinder Head Warp

**Standard:** - - -

**Service Limit: 0.05 mm (0.002 in.)**

- ★ If the cylinder head is warped more than the service limit, replace it.
- ★ If the cylinder head is warped less than the service limit, repair the head by rubbing the lower surface on emery paper secured to a surface plate (first No. 200, then No. 400).

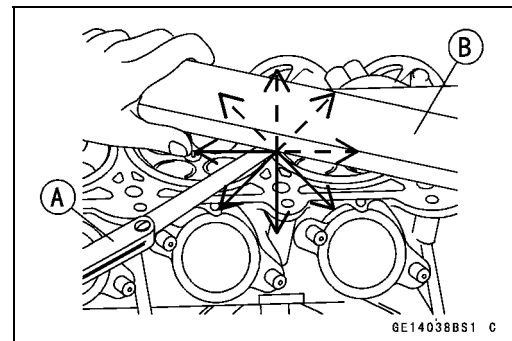

**Valves**

*Valve Clearance Inspection*

- Refer to the Valve Clearance Inspection in the Periodic Maintenance chapter.

*Valve Removal*

- Remove the cylinder head (see Cylinder Head Removal).
- Remove the valve lifter and shim.
- Mark and record the valve lifter and shim locations so they can be installed in their original positions.
- Using the valve spring compressor assembly, remove the valve.

**Special Tools - Valve Spring Compressor Assembly: 57001-241 [A]**

**Adapter,  $\phi$ 24: 57001-1586 [B]**

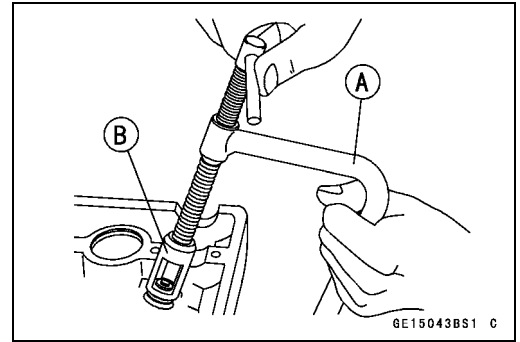

*Valve Installation*

**CAUTION**

**Do not lap the exhaust valve to the exhaust valve seat, using the grinding compound. It will come off oxide film treated surface of the valve.**

- Replace the oil seal with a new one.
- Apply a thin coat of molybdenum disulfide grease to the valve stem before valve installation.
- Install the springs so that the closed coil end faces downwards.

- Valve Stem [A]
- Oil Seal [B]
- Spring Seat [C]
- Closed Coil End [D]
- Valve Spring [E]:
  - EX-Purple Paint
  - IN-Green Paint
- Retainer [F]
- Split Keepers [G]

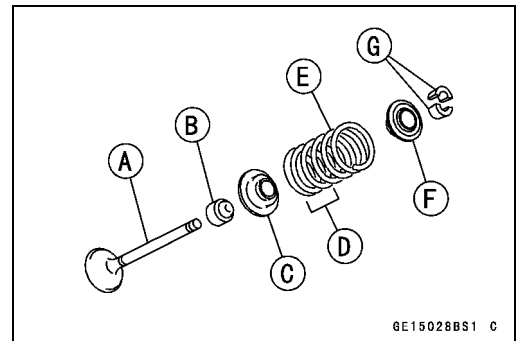

*Valve Guide Removal*

- Remove:
  - Valve (see Valve Removal)
  - Oil Seal
  - Spring Seat
- Heat the area around the valve guide to 120 ~ 150°C (248 ~ 302°F), and hammer lightly on the valve guide arbor [A] to remove the guide from the top of the head.

**CAUTION**

**Do not heat the cylinder head with a torch. This will warp the cylinder head. Soak the cylinder head in oil and heat the oil.**

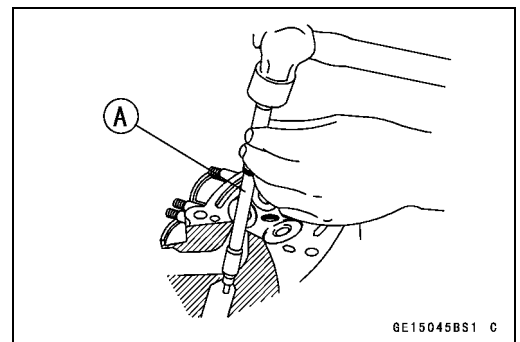

**Special Tool - Valve Guide Arbor,  $\phi$ 4.5: 57001-1331**

## 5-22 ENGINE TOP END

### Valves

#### Valve Guide Installation

- Apply oil to the valve guide outer surface before installation.
- Heat the area around the valve guide hole to about 120 ~ 150°C (248 ~ 302°F).

#### CAUTION

**Do not heat the cylinder head with a torch. This Will warp the cylinder head. Soak the cylinder head and heat the oil.**

- Using the valve guide driver [A] and washer [B], press and insert the valve guide in until the valve guide driver surface [C] touches the head surface [D].

13.3 ~ 13.5 mm (0.52 ~ 0.53 in.) [E]

**Special Tools - Valve Guide Driver: 57001-1564**

**Washer: 57001-1612**

- Ream the valve guide with valve guide reamer [A], even if the old guide is reused.

**Special Tool - Valve Guide Reamer,  $\phi$ 4.5: 57001-1333**

#### Valve-to-Guide Clearance Measurement (Wobble Method)

If a small bore gauge is not available, inspect the valve guide wear by measuring the valve to valve guide clearance with the wobble method as indicated below.

- Insert a new valve [A] into the guide [B] and set a dial gauge against the stem perpendicular to it as close as possible to the cylinder head mating surface.
- Move the stem back and forth [C] to measure valve/valve guide clearance.
- Repeat the measurement in a direction at a right angle to the first.

★ If the reading exceeds the service limit, replace the guide.

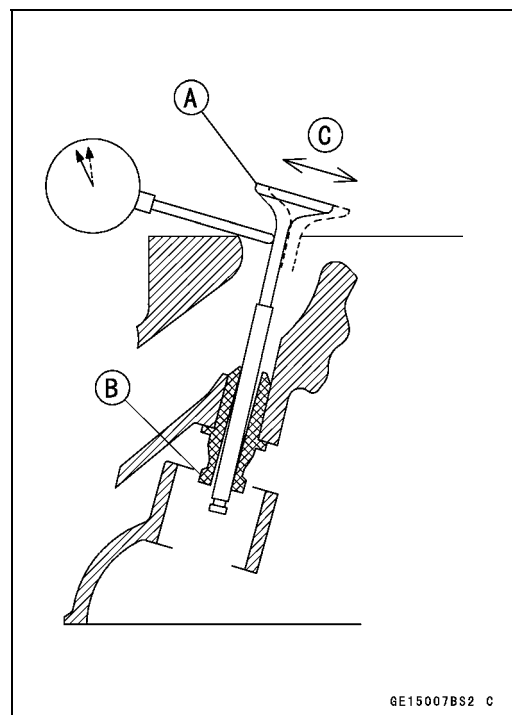
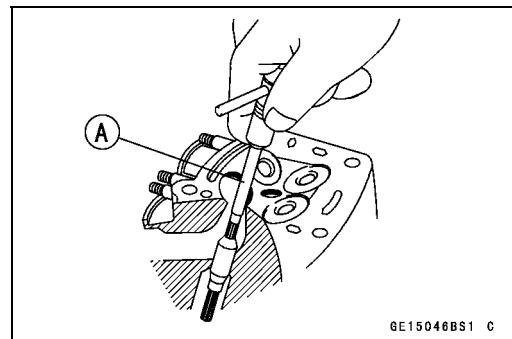
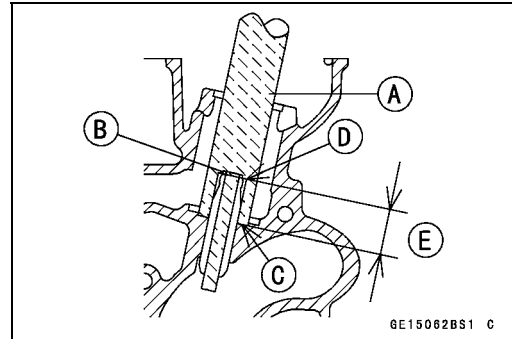
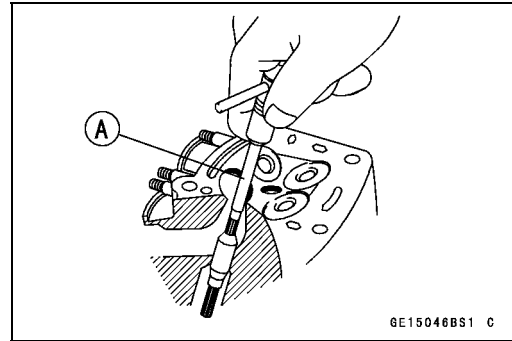

## Valves

### NOTE

- The reading is not actual valve/valve guide clearance because the measuring point is above the guide.

### Valve/Valve Guide Clearance (Wobble Method)

#### Standard:

Exhaust	0.05 ~ 0.13 mm (0.0020 ~ 0.0051 in.)
Inlet	0.03 ~ 0.11 mm (0.0012 ~ 0.0043 in.)

#### Service Limit:

Exhaust	0.36 mm (0.014 in.)
Inlet	0.36 mm (0.014 in.)

### Valve Seat Inspection

- Remove the valve (see Valve Removal).
- Check the valve seating surface [A] between the valve [B] and valve seat [C].
- Measure the outside diameter [D] of the seating pattern on the valve seat.
- ★ If the outside diameter is too large or too small, repair the seat (see Seat Repair).

### Valve Seating Surface Outside Diameter

#### Standard:

Exhaust	24.9 ~ 25.1 mm (0.980 ~ 0.988 in.)
Inlet	30.4 ~ 30.6 mm (1.197 ~ 1.205 in.)

- Measure the seat width [E] of the portion where there is no build-up carbon (white portion) of the valve seat with a vernier caliper.

Good [F]

- ★ If the width is too wide [G], too narrow [H] or uneven [J], repair the seat (see Valve Seat Repair).

### Valve Seating Surface Width

#### Standard:

Exhaust	0.8 ~ 1.2 mm (0.031 ~ 0.047 in.)
Inlet	0.5 ~ 1.0 mm (0.020 ~ 0.039 in.)

### Valve Seat Repair

- Repair the valve seat with the valve seat cutters [A].

Special Tools - Valve Seat Cutter Holder Bar: 57001-1128 [C]

Valve Seat Cutter Holder,  $\phi$ 4.5: 57001-1330 [B]

#### For Exhaust Valve Seat

Valve Seat Cutter, 45° -  $\phi$ 27.5: 57001-1114

Valve Seat Cutter, 32° -  $\phi$ 33: 57001-1119

Valve Seat Cutter, 60° -  $\phi$ 25: 57001-1328

#### For Inlet Valve Seat

Valve Seat Cutter, 45° -  $\phi$ 32: 57001-1115

Valve Seat Cutter, 32° -  $\phi$ 33: 57001-1199

Valve Seat Cutter, 60° -  $\phi$ 33: 57001-1334

- ★ If the manufacturer's instructions are not available, use the following procedure.

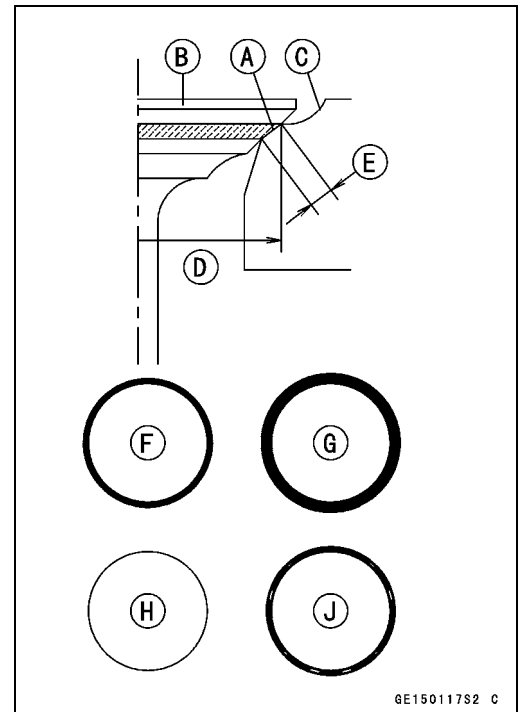

6E150117S2 C

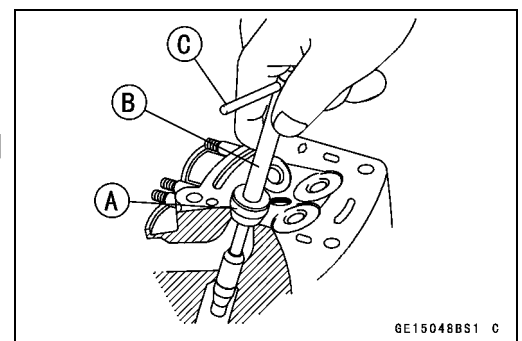

6E15048BS1 C

## 5-24 ENGINE TOP END

### Valves

#### Seat Cutter Operation Care

1. This valve seat cutter is developed to grind the valve for repair. Therefore the cutter must not be used for other purposes than seat repair.
2. Do not drop or shock the valve seat cutter, or the diamond particles may fall off.
3. Do not fail to apply engine oil to the valve seat cutter before grinding the seat surface. Also wash off ground particles sticking to the cutter with washing oil.

#### NOTE

○Do not use a wire brush to remove the metal particles from the cutter. It will take off the diamond particles.

4. Setting the valve seat cutter holder in position, operate the cutter in one hand. Do not apply too much force to the diamond portion.

#### NOTE

○Prior to grinding, apply engine oil to the cutter and during the operation, wash off any ground particles sticking to the cutter with washing oil.

5. After use, wash it with washing oil and apply thin layer of engine oil before storing.

#### Marks Stamped on the Cutter

The marks stamped on the back of the cutter [A] represent the following.

- 60° ..... Cutter angle [B]  
φ37.5 ..... Outer diameter of cutter [C]

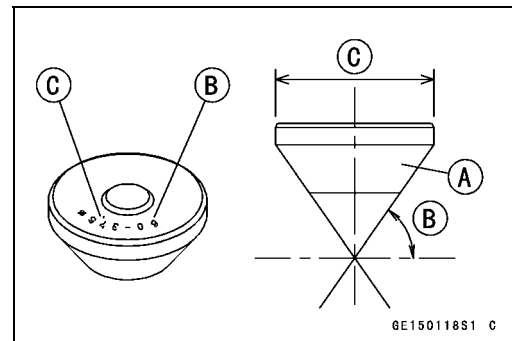

#### Operating Procedures

- Clean the seat area carefully.
- Coat the seat with machinist's dye.
- Fit a 45° cutter into the holder and slide it into the valve guide.
- Press down lightly on the handle and turn it right or left. Grind the seating surface only until it is smooth.

#### CAUTION

**Do not grind the seat too much. Overgrinding will reduce valve clearance by sinking the valve into the head. If the valve sinks too far into the head, it will be impossible to adjust the clearance, and the cylinder head must be replaced.**

**Valves**

- Measure the outside diameter of the seating surface with a vernier caliper.
- ★ If the outside diameter of the seating surface is too small, repeat the 45° grind until the diameter is within the specified range.
  - Widened Width [A] of engagement by machining with 45° cutter
  - Ground Volume [B] by 32° cutter
  - 32° [C]
  - Correct Width [D]
  - Ground Volume [E] by 60° cutter
  - 60° [F]

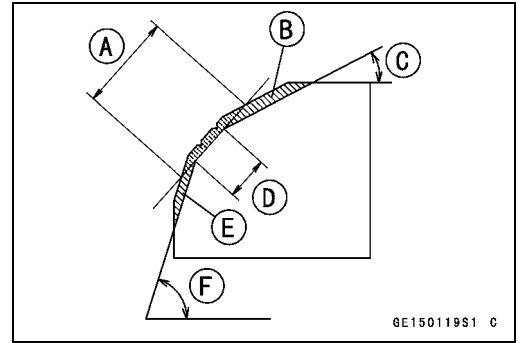

- Measure the outside diameter of the seating surface with a vernier caliper.
- ★ If the outside diameter of the seating surface is too small, repeat the 45° grind [A] until the diameter is within the specified range.
  - Original Seating Surface [B]

**NOTE**

- Remove all pittings of flaws from 45° ground surface.
- After grinding with 45° cutter, apply thin coat of machinist's dye to seating surface. This makes seating surface distinct and 32° and 60° grinding operation easier.
- When the valve guide is replaced, be sure to grind with 45° cutter for centering and good contact.

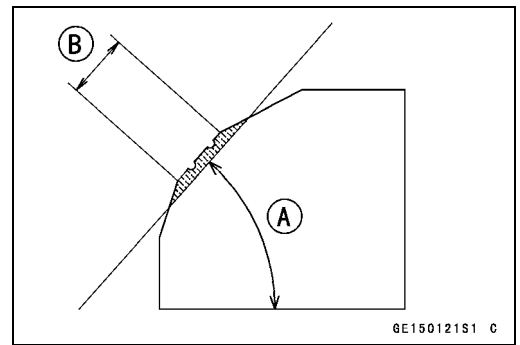

- ★ If the outside diameter [A] of the seating surface is too large, make the 32° grind described below.
- ★ If the outside diameter of the seating surface is within the specified range, measure the seat width as described below.
- Grind the seat at a 32° angle [B] until the seat O.D. is within the specified range.
  - To make the 32° grind, fit a 32° cutter into the holder, and slide it into the valve guide.
  - Turn the holder one turn at a time while pressing down very lightly. Check the seat after each turn.

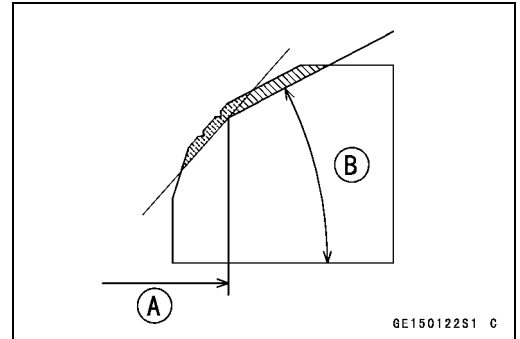

**CAUTION**

**The 32° cutter removes material very quickly. Check the seat outside diameter frequently to prevent overgrinding.**

- After making the 32° grind, return to the seat O.D. measurement step above.
- To measure the seat width, use a vernier caliper to measure the width of the 45° angle portion of the seat at several places around the seat.
- ★ If the seat width is too narrow, repeat the 45° grind until the seat is slightly too wide, and then return to the seat O.D. measurement step above.

## 5-26 ENGINE TOP END

### Valves

- ★ If the seat width is too wide, make the 60° [A] grind described below.
- ★ If the seat width is within the specified range, lap the valve to the seat as described below.
- Grind the seat at a 60° angle until the seat width is within the specified range.
- To make the 60° grind, fit 60° cutter into the holder, and slide it into the valve guide.
- Turn the holder, while pressing down lightly.
- After making the 60° grind, return to the seat width measurement step above.  
Correct Width [B]

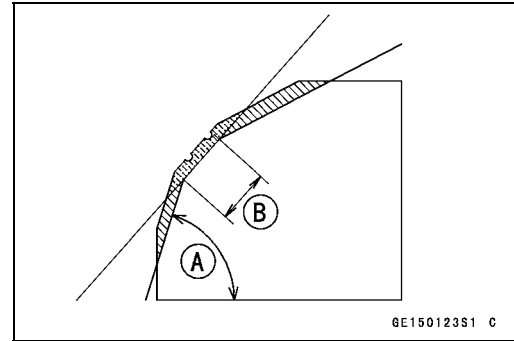

#### CAUTION

**Do not lap the exhaust valve to the exhaust valve seat, using the grinding compound. It will come off oxide film treated surface of the valve.**

- Lap the inlet valve to the inlet valve seat, once the seat width and O.D. are within the ranges specified above.
- Put a little coarse grinding compound on the face of the valve in a number of places around the valve head.
- Spin the valve against the seat until the grinding compound produces a smooth, matched surface on both the seat and the valve.
- Repeat the process with a fine grinding compound.  
Lapper [A]  
Valve Seat [B]  
Valve [C]
- The seating area should be marked about in the middle of the valve face.
- ★ If the seat area is not in the right place on the valve, check to be sure the valve is the correct part. If it is, it may have been refaced too much; replace it.
- Be sure to remove all grinding compound before assembly.
- When the engine is assembled, be sure to adjust the valve clearance (see Valve Clearance Inspection in the Periodic Maintenance chapter).

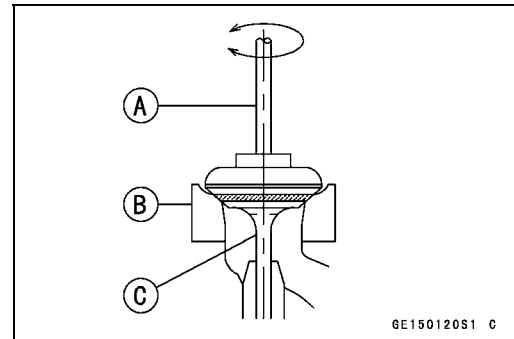



Valves

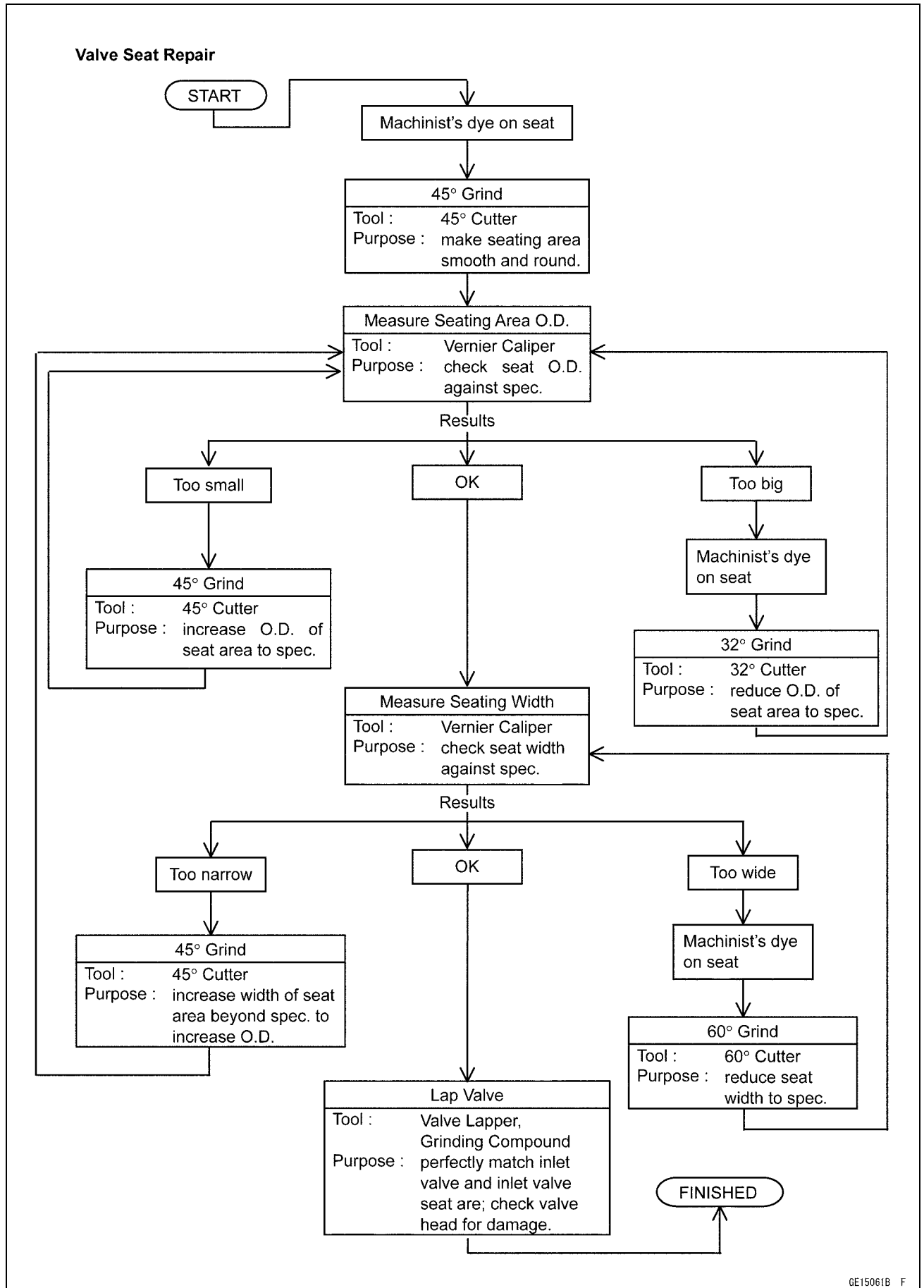

## 5-28 ENGINE TOP END

### Throttle Body Holder

#### *Throttle Body Holder Installation*

- Be sure to install the O-rings [A].
- Install the clamps [B] as shown.
- Tighten the holder bolts following the tightening sequence [1 ~ 3].

**Torque - Throttle Body Holder Bolts [C]: 9.8 N·m (1.0 kgf·m, 87 in·lb)**

**Throttle Body Assy Holder Clamp Bolts [D]: 2.0 N·m (0.20 kgf·m, 17 in·lb)**

Upside [E]

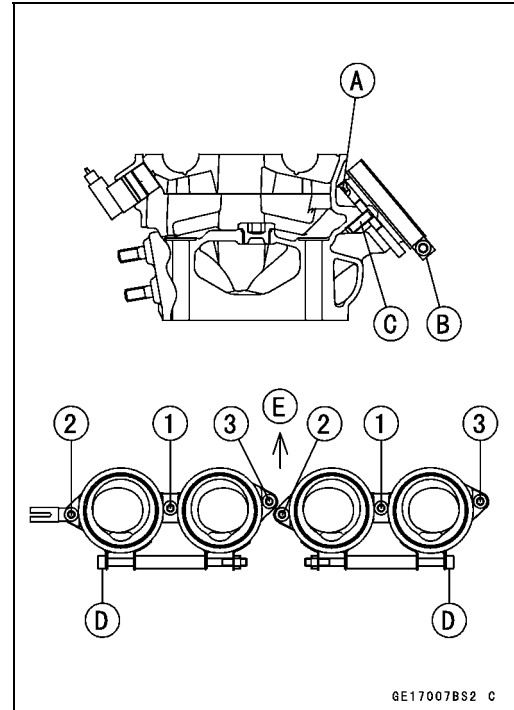

## Muffler

### **⚠ WARNING**

To avoid a serious burn, do not remove the muffler when the engine is still hot. Wait until the muffler cool down.

### *Muffler Body Removal/Installation*

- Remove:
    - Muffler Body Assembly Nuts [A]
    - Muffler Body Mounting Bolt [B]
  - Pull the muffler body backward.
  
  - Replace the muffler body gasket [A] with a new one and install it.
  - Install the muffler body.
    - Washers [B]
    - Collars [C]
    - Damper [D]
    - Nut
  - Tighten:
    - Torque - Muffler Body Assembly Nuts [E]: 22 N·m (2.2 kgf·m, 16 ft·lb)**
    - Muffler Body Mounting Bolt [F]: 25 N·m (2.5 kgf·m, 18 ft·lb)**
- Outside [G]  
Upside [H]

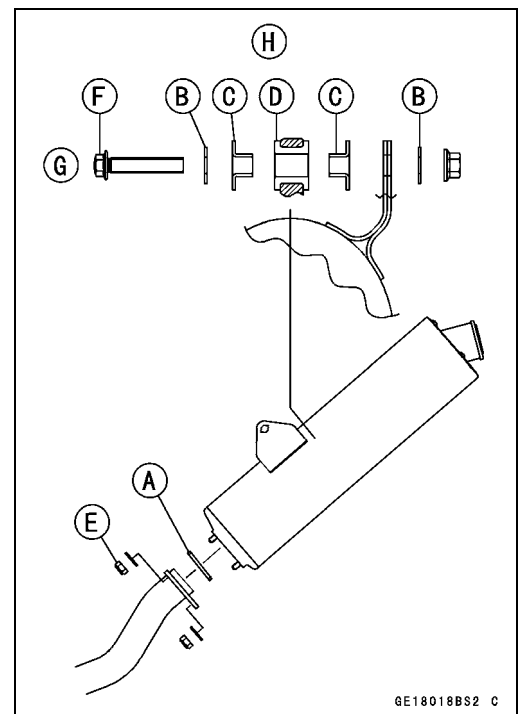
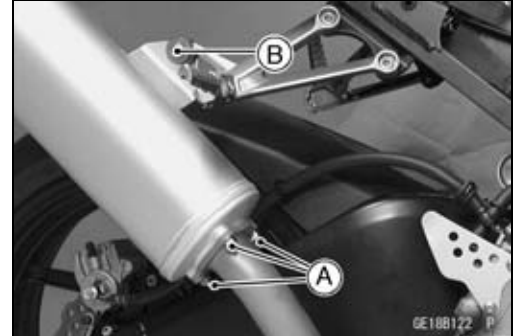

### *Exhaust Pipe Removal*

- Remove:
  - Lower Fairing (see Frame chapter)
  - Radiator (see Cooling System chapter)
  - Front Seat and Right Side Cover (see Frame chapter)
- Slide the dust covers [A].
- Loosen the nuts [B], and slide the cables to give the cable plenty of play.

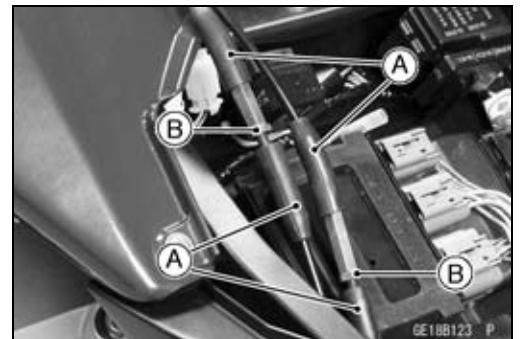

## 5-30 ENGINE TOP END

### Muffler

- Remove the clamp [A].
- Remove the exhaust butterfly valve cable upper ends [B] from the pulley [C].

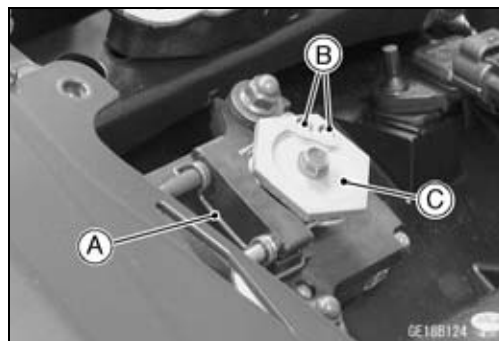

- Remove the exhaust pipe manifold holder nuts [A].

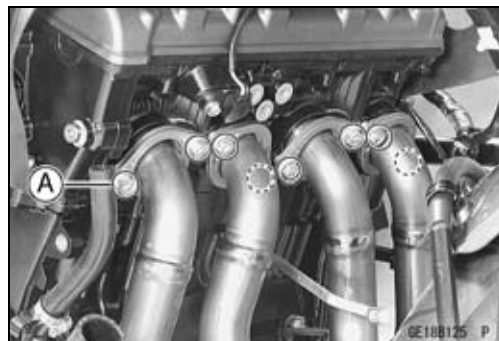

- Remove the muffler body mounting bolts [A].

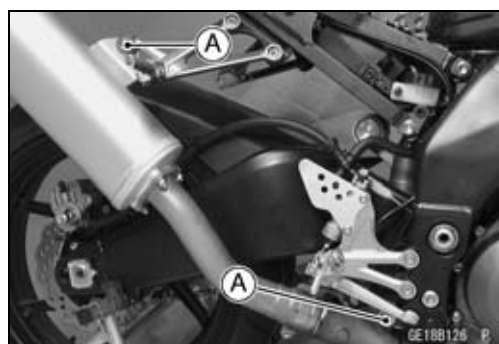

- Remove the clamps [A].
- Remove the muffler assy from the chassis.

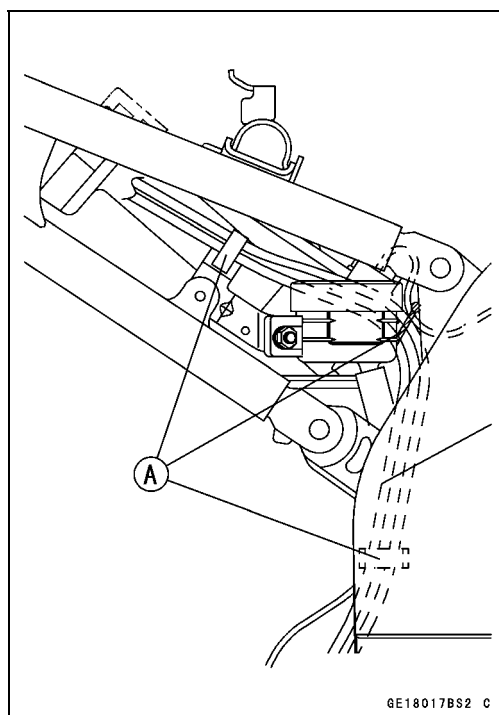

## Muffler

- Remove the cover bolts [A] and cover [B].

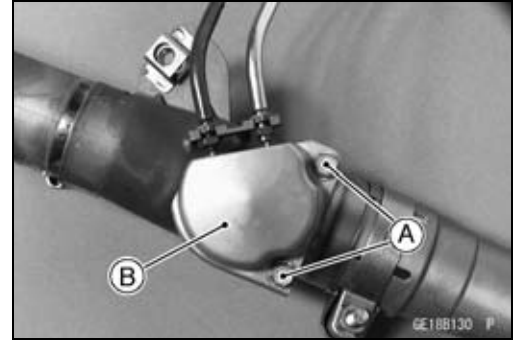

- Loosen the locknuts [A].
- Remove the exhaust butterfly valve cable lower ends [B] from the pulley.
- Remove the muffler body clamp bolt.
- Remove the muffler body (see Muffler Body Removal).

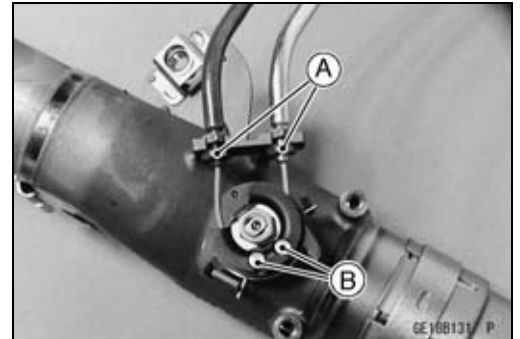

### Exhaust Pipe Installation

- Replace the exhaust pipe gaskets [A], muffler body gasket [B] and muffler body connection gasket [C] with new ones and install them.
- Install the muffler body connection gasket until it is bottomed so that the chamfer side faces front [D].
- Install:
  - Muffler Body [E]
  - Exhaust Pipe [F]
- Install the muffler body clamp bolt as shown.
  - Upper Side [G]
  - Outside [H]
  - 30° ~ 50° [I]
- Tighten:
  - Torque - Muffler Body Clamp Bolt [J]: 17 N·m (1.7 kgf·m, 12 ft·lb)**
  - Muffler Body Assembly Nuts [K]: 22 N·m (2.2 kgf·m, 16 ft·lb)**

## 5-32 ENGINE TOP END

### Muffler

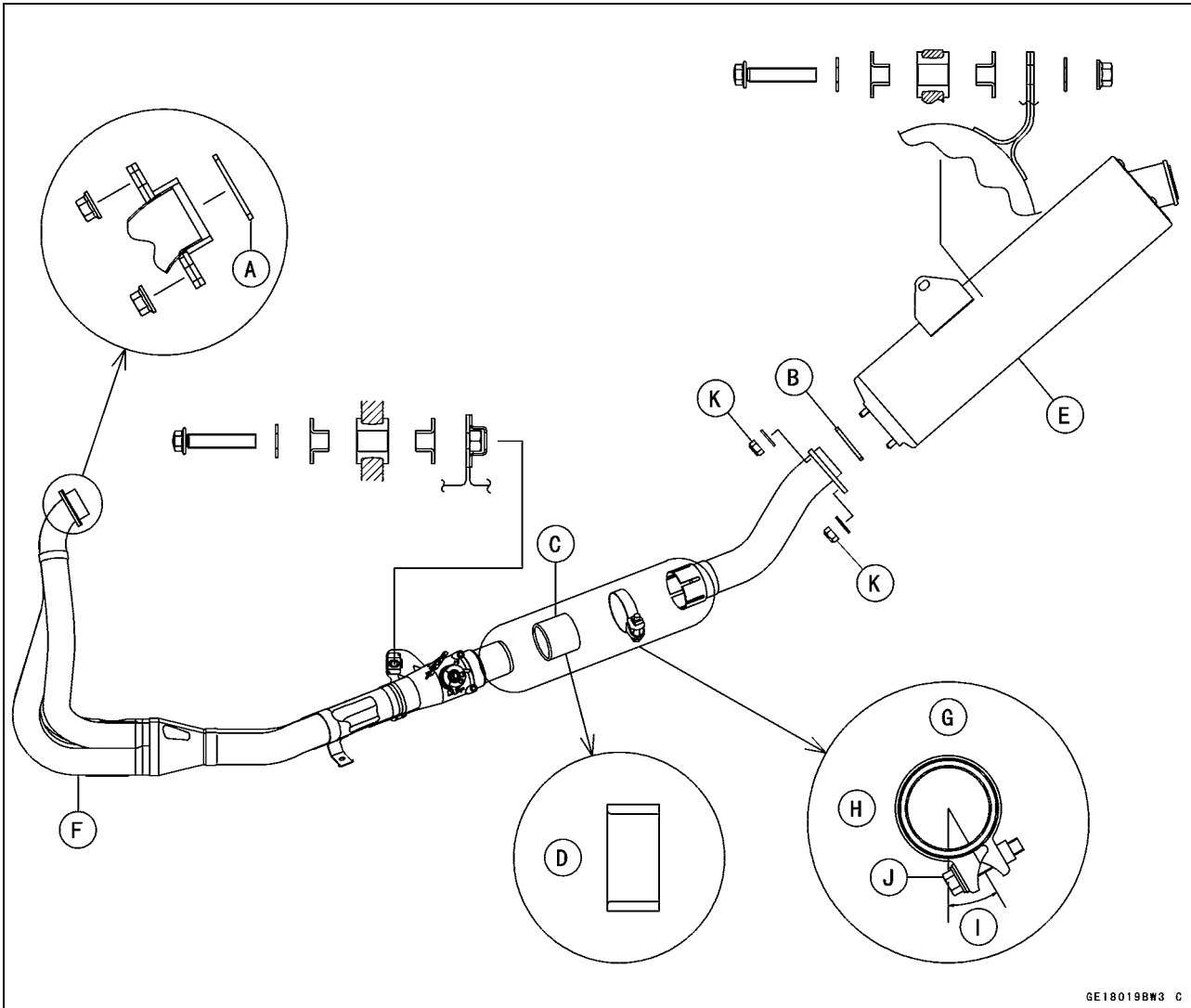

GE18019BW3 C

- Install the exhaust butterfly valve cable lower ends to the pulley of exhaust pipe.  
Open Cable (Yellow) [A]  
Close Cable (Dark Green) [B]  
6 mm (0.24 in.) [C]  
about 45° [D]
- Tighten:  
**Torque - Exhaust Butterfly Valve Cable Locknuts [E]: 7.0 N·m (0.71 kgf·m, 62 in·lb)**

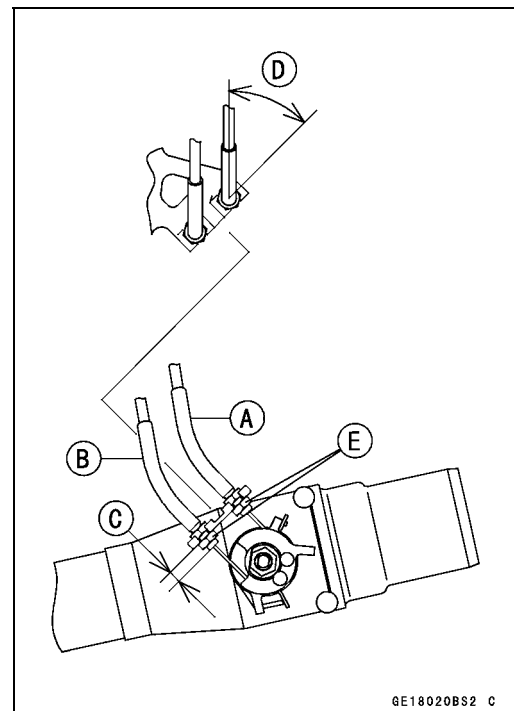

GE18020BS2 C

## Muffler

- Install the exhaust butterfly valve cover.
- Tighten:
  - Torque - Exhaust Butterfly Valve Cover Bolts [A]: 8.8 N·m (0.90 kgf·m, 78 in·lb)**



- Install the muffler assy to the chassis.
- Tighten:
  - Torque - Exhaust Pipe Manifold Holder Nuts: 17 N·m (1.7 kgf·m, 12 ft·lb)**
  - Muffler Body mounting Bolts: 25 N·m (2.5 kgf·m, 18 ft·lb)**

- When installing, run the cables correctly (see Cable, Wire and Hose Routing section in Appendix chapter).
- Install and adjust the exhaust butterfly valve cable (see Exhaust Butterfly Valve Cable Installation).
- Thoroughly warm up the engine, wait until the engine cools down, retighten all the bolts and nuts.

### *Exhaust Butterfly Valve Cable Removal*

- Remove the front seat and right side cover (see Frame chapter).
- Slide the dust covers [A].
- Loosen the nuts [B], and slide the cables to give the cable plenty of play.

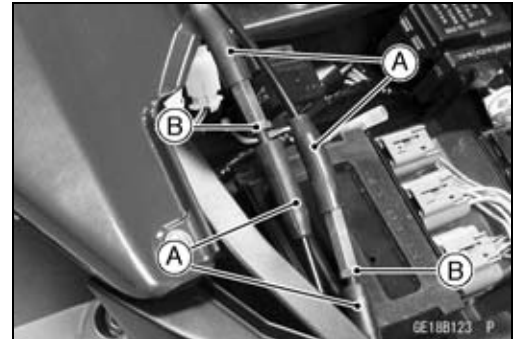

- Remove the clamp [A].
- Remove the exhaust butterfly valve cable upper ends [B] from the pulley [C].

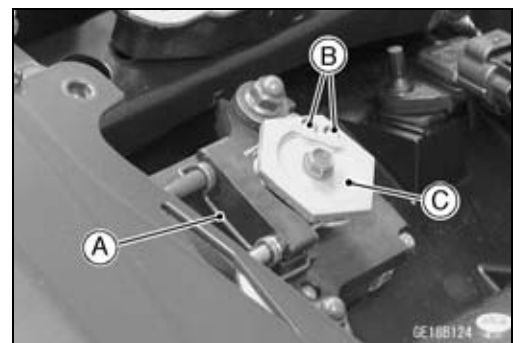

## 5-34 ENGINE TOP END

### Muffler

- Remove the clamps [A].

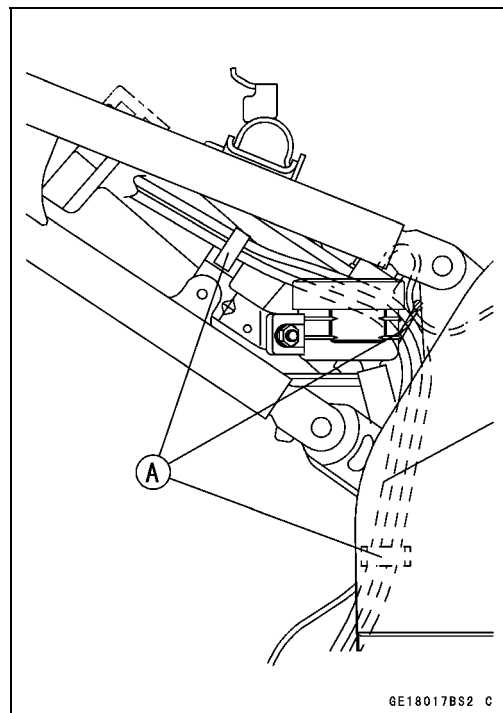

- Remove the cover bolts [A] and cover [B].

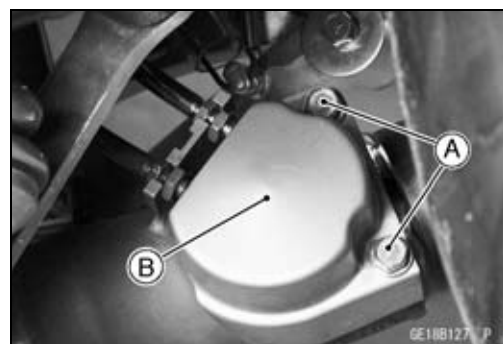

- Loosen the locknuts [A].
- Remove the exhaust butterfly valve cable lower ends [B] from the pulley.
- Remove the exhaust butterfly valve cable.





**Muffler**

*Exhaust Butterfly Valve Cable Installation*

- Install the exhaust butterfly valve cable lower ends to the pulley of exhaust pipe.
  - Open Cable (Yellow) [A]
  - Close Cable (Dark Green) [B]
  - 6 mm (0.24 in.) [C]
  - About 45° [D]
- Tighten:
  - Torque - Exhaust Butterfly Valve Cable Locknuts [E]: 7.0 N·m (0.71 kgf·m, 62 in·lb)

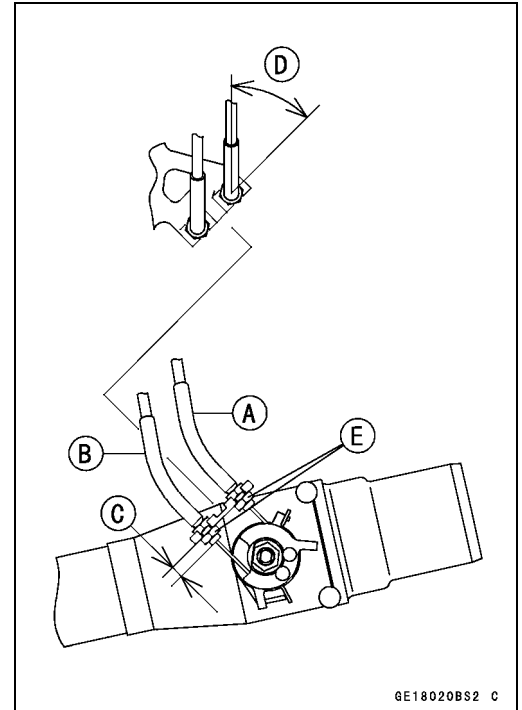

- Install the exhaust butterfly valve cover.
- Tighten:
  - Torque - Exhaust Butterfly Valve Cover Bolts [A]: 8.8 N·m (0.90 kgf·m, 78 in·lb)

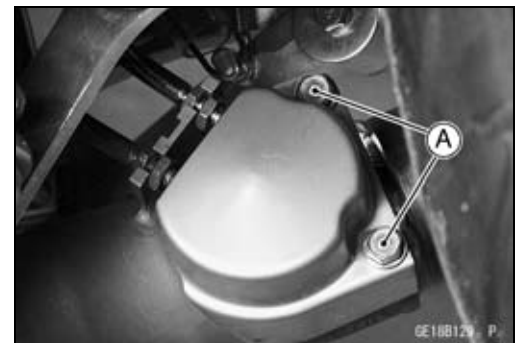

- Confirm whether it is an angle shown in figure.

**NOTE**

○Correct the position electrically after confirming use is discontinued, and there is no damage when differing from the angle of shown in the figure.

- ★If the angle is wrong, adjust the pulley (see Fuel System (DFI) chapter).
  - 41.7° ±7° [A]

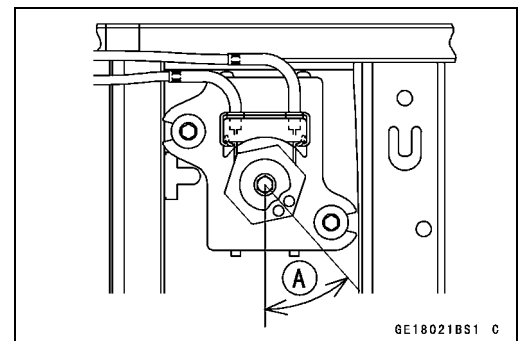

**CAUTION**

**Do not correct it with the tool, forcibly.**

## 5-36 ENGINE TOP END

### Muffler

#### CAUTION

To keep the correct exhaust butterfly valve position, install the open cable first.

- Install the open cable to the pulley, and adjust the adjuster [A] until the clearance of part [B] of figure come to 0 mm.

#### CAUTION

Do not overstretch.

- Tighten:  
Torque - Exhaust Butterfly Valve Cable Adjuster Locknut:  
7.0 N·m (0.71 kgf·m, 62 in·lb)
- Install the close cable to the pulley, and adjust the adjuster [C] until the clearance of part [B] of figure come to 0 mm.
- After the adjustment, the half rotation returns the nut (free play becomes 0.5 mm (0.02 in.)).
- Tighten:  
Torque - Exhaust Butterfly Valve Cable Adjuster Locknut:  
7.0 N·m (0.71 kgf·m, 62 in·lb)
- Install the clamp [D].
- It covers with the cover as shown in figure.  
10 mm (0.39 in.) or less [E]  
15 mm (0.59 in.) or less [F]

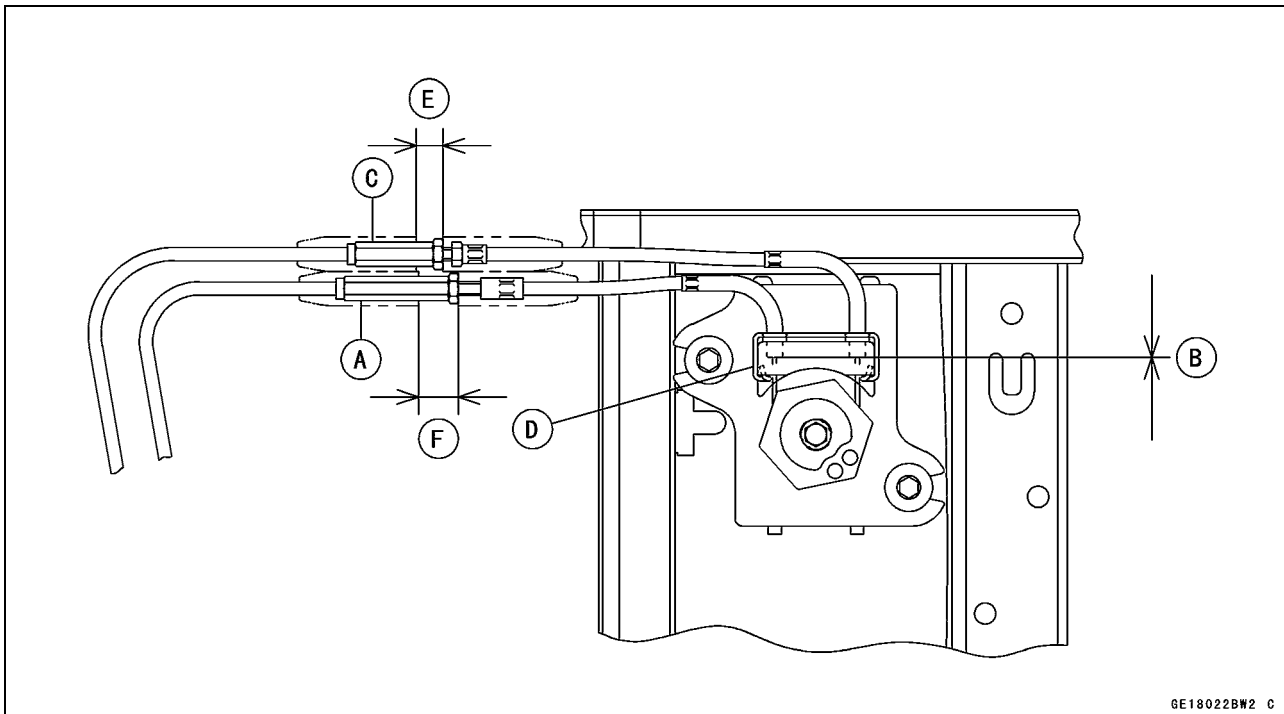

- When installing, run the cables correctly (see Cable, Wire and Hose Routing section in Appendix chapter).

# Clutch

## Table of Contents

Exploded View .....	6-2
Specifications .....	6-4
Special Tool .....	6-5
Clutch Lever and Cable .....	6-6
Clutch Lever Free Play Inspection .....	6-6
Clutch Lever Free Play Adjustment .....	6-6
Cable Removal .....	6-6
Cable Installation .....	6-6
Cable Lubrication .....	6-6
Clutch Lever Installation .....	6-6
Clutch Cover .....	6-7
Clutch Cover Removal .....	6-7
Clutch Cover Installation .....	6-7
Release Shaft Removal .....	6-8
Release Shaft Installation .....	6-8
Clutch Cover Disassembly .....	6-8
Clutch Cover Assembly .....	6-9
Clutch .....	6-10
Clutch Removal .....	6-10
Clutch Installation .....	6-11
Spring Plate Free Play Measurement .....	6-14
Spring Plate Play Adjustment .....	6-15
Clutch Plate, Wear, Damage Inspection .....	6-15
Clutch Plate Warp Inspection .....	6-15
Clutch Spring Free Length Measurement .....	6-16
Damper Cam Inspection .....	6-16



**Exploded View**

No.	Fastener	Torque			Remarks
		N·m	kgf·m	ft·lb	
1	Clutch Lever Clamp Bolts	7.8	0.80	69 in·lb	S
2	Clutch Cover Mounting Bolts (M6, L = 40 mm)	9.8	1.0	87 in·lb	S
3	Clutch Cover Mounting Bolt (M6, L = 30 mm)	9.8	1.0	87 in·lb	S
4	Clutch Cover Mounting Bolts (M6, L = 25 mm)	9.8	1.0	87 in·lb	S
5	Oil Filler Plug	2.0	0.20	18 in·lb	
6	Clutch Spring Bolts	9.8	1.0	87 in·lb	
7	Clutch Hub Nut	130	13	96	R
8	Sub Clutch Hub Bolts	11	1.1	95 in·lb	L

CL: Apply cable lubricant.

EO: Apply engine oil.

G: Apply grease.

M: Apply molybdenum disulfide grease.

R: Replacement Parts

S: Follow the specific tightening sequence.

## 6-4 CLUTCH

### Specifications

Item	Standard	Service Limit
<b>Clutch Lever Free Play</b>	2 ~ 3 mm (0.08 ~ 0.12 in.)	— — —
<b>Clutch</b>		
Spring Plate Free Play	(Usable Range) 0.05 ~ 0.35 mm (0.002 ~ 0.014 in.)	— — —
Clutch Plate Assembly	53.6 mm (2.11 in.)	— — —
Friction Plate Thickness	2.72 ~ 2.88 mm (0.107 ~ 0.113 in.)	2.6 mm (0.102 in.)
Friction and Steel Plate Warp	0.2 mm (0.008 in.) or less	0.3 mm (0.012 in.)
Clutch Spring Free Length	43.5 mm (1.71 in.)	42.1 mm (1.66 in.)

### Clutch Housing Gear and Needle Bearing Selection

Clutch Housing Gear Marking (Right)	Needle Bearing	
	Size Color	Part Number
1	White	92046-0010
2	Blue	92046-0011
3	Red	92046-1263

---

**Special Tool**

---

**Clutch Holder:  
57001-1243**

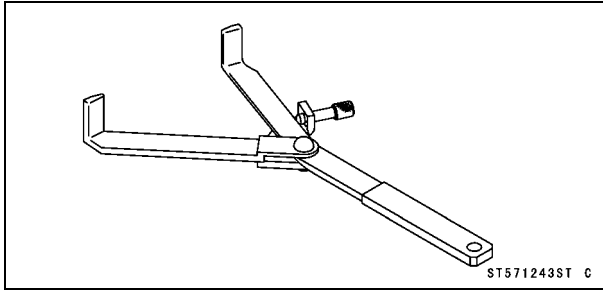

## 6-6 CLUTCH

### Clutch Lever and Cable

#### Clutch Lever Free Play Inspection

- Refer to the Clutch Adjustment Inspection in the Periodic Maintenance chapter.

#### Clutch Lever Free Play Adjustment

- Refer to the Clutch Adjustment Inspection in the Periodic Maintenance chapter.

#### Cable Removal

- Slide the dust cover [A] at the clutch cable lower end out of place.
- Loosen the nuts [B], and slide the lower end of the clutch cable to give the cable plenty of play.

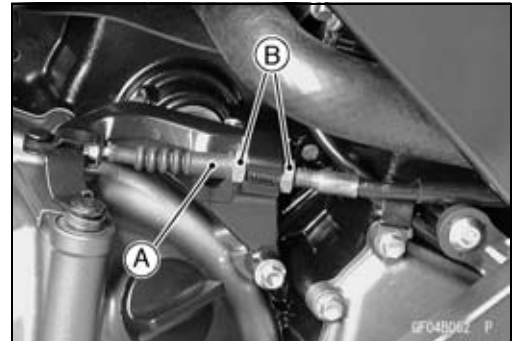

- Screw in the adjuster.
- Line up the slots [A] in the clutch lever and adjuster [B], and then free the cable from the lever.
- Free the clutch inner cable tip from the clutch release lever.
- Push the release lever toward the front of the motorcycle and tape the release lever to the clutch cover to prevent the release shaft from falling out.
- Pull the clutch cable out of the frame.



#### Cable Installation

- Run the clutch cable correctly (see Appendix chapter).
- Adjust the clutch cable (see Clutch Adjustment Inspection in the Periodic Maintenance chapter).

#### Cable Lubrication

- Refer to the Chassis Parts Lubrication in the Periodic Maintenance chapter.

#### Clutch Lever Installation

- Install the clutch lever so that the mating surface [A] of the clutch lever clamp is aligned with the punch mark [B].
- Tighten the upper clamp bolt first, and then the lower clamp bolt. There will be a gap at the lower part of the clamp after tightening.

**Torque - Clutch Lever Clamp Bolts: 7.8 N·m (0.80 kgf·m, 69 in·lb)**

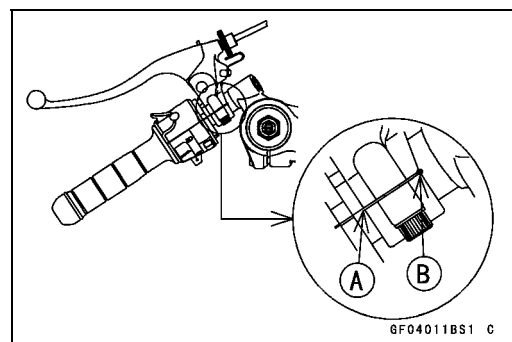



## Clutch Cover

### Clutch Cover Removal

- Remove:
  - Engine Oil (Drain, see Engine Oil Change in the Periodic Maintenance chapter)
  - Right Lower Fairing (see Frame chapter)
  - Clutch Cable Lower End [A]
  - Clutch Cover Mounting Bolts [B]

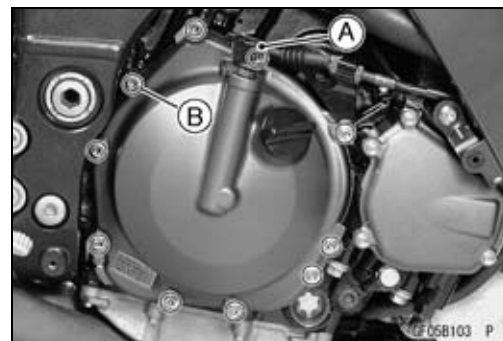

- Turn the release lever [A] toward the rear as shown, and remove the clutch cover [B].  
About 90° [C]

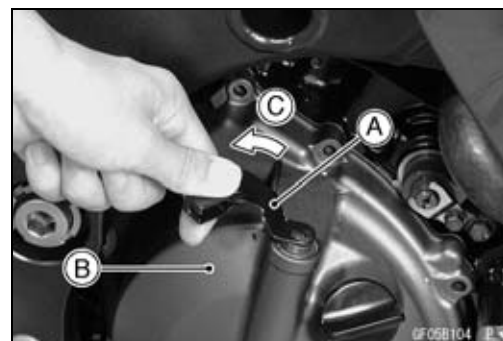

### Clutch Cover Installation

- Apply silicone sealant to the area [A] where the mating surface of the crankcase touches the clutch cover gasket.  
**Sealant - Three Bond (Silicone Sealant): TB1211F**

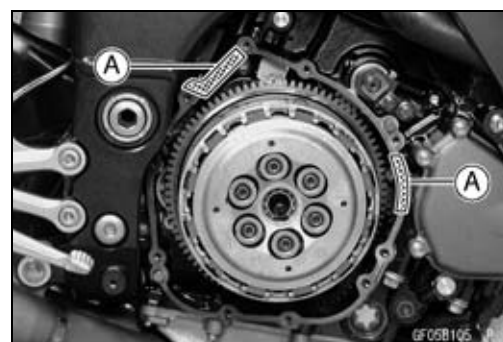

- Replace the clutch cover gasket with a new one.
- Tighten the clutch cover mounting bolts following the tightening sequence [1 ~ 10].

**Torque - Clutch Cover Mounting Bolts: 9.8 N·m (1.0 kgf·m, 87 in·lb)**

L = 40 mm (1.57 in.) [A]

L = 30 mm (1.18 in.) [B]

L = 25 mm (0.98 in.) [C]

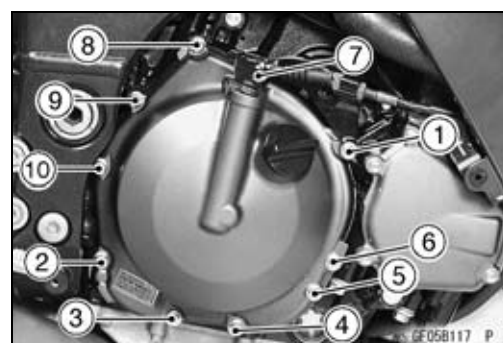
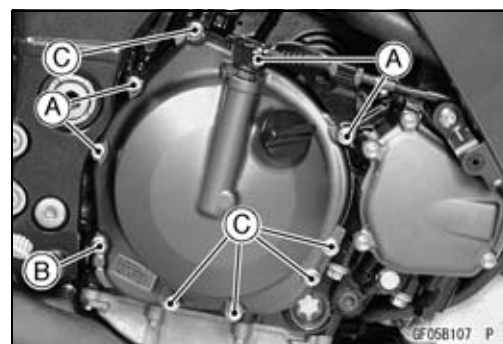

## 6-8 CLUTCH

### Clutch Cover

#### Release Shaft Removal

#### CAUTION

**Do not remove the clutch release lever and shaft assembly unless it is absolutely necessary. If removed, the oil seal replacement may be required.**

- Remove the clutch cover (see Clutch Cover Removal).
- Pull the lever and shaft assembly straight out of the clutch cover.

#### Release Shaft Installation

- Apply high-temperature grease to the oil seal lips on the upper ridge of the clutch cover.
- Apply oil to the needle bearings in the hole of the clutch cover.
- Apply molybdenum disulfide grease to the pusher-holding portion [A] on the release shaft.
- Install the washer [B] and spring [C].
- Insert the release shaft straight into the upper hole of the clutch cover.

#### CAUTION

**When inserting the release shaft, be careful not to remove the spring of the oil seal.**

- Fit the spring [A] as shown.  
Viewed from Rear [B]  
Release Shaft [C]  
Clutch Cover [D]

#### Clutch Cover Disassembly

- Remove:  
Oil Seal  
Needle Bearings [A]

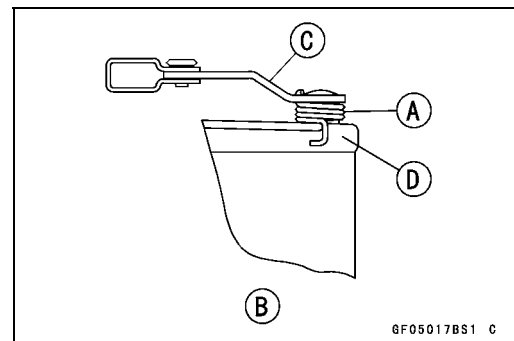
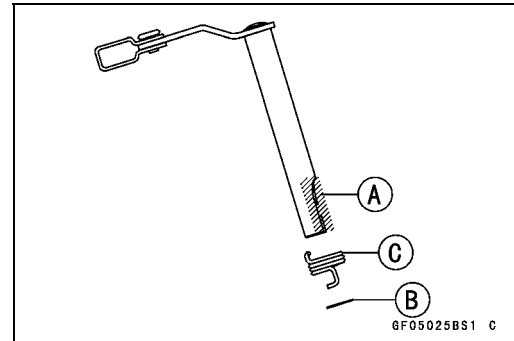

## Clutch Cover

### Clutch Cover Assembly

- Replace the needle bearings and oil seal with new ones.

#### NOTE

- *Install the needle bearings so that the manufacture's mark face out.*
- Install the needle bearings [A] and oil seal [B] position as shown.
  - Press the bearing until the bottom [C].
  - Press the bearing so that the bearing surface [D] is flush with the housing end of clutch cover [E].

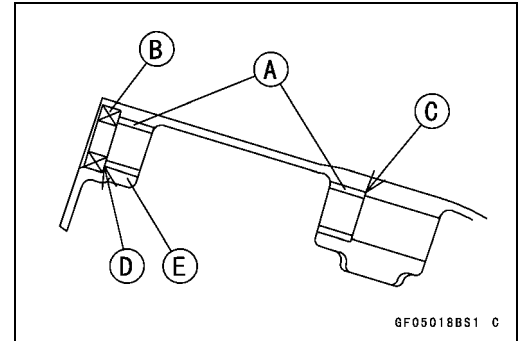

## 6-10 CLUTCH

### Clutch

#### Clutch Removal

- Remove:
  - Engine Oil (Drain, see Engine Oil Change in the Periodic Maintenance chapter)
  - Lower Fairing (see Frame chapter)
  - Clutch Cover (see Clutch Cover Removal)
  - Clutch Spring Bolts [A]
  - Clutch Springs
  - Clutch Spring Plate [B] (with bearing and pusher [C])

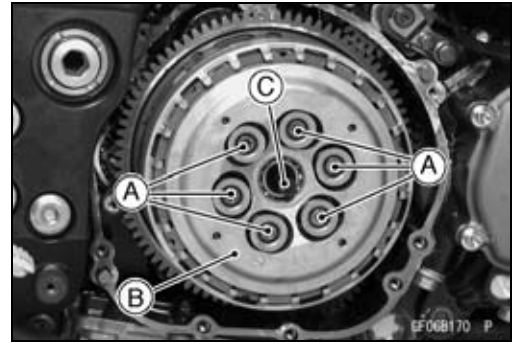

- Use the clutch holder with sharpened hook nose by grinding.

**Special Tool - Clutch Holder: 57001-1243**

- Grind the hook nose by 0.5 mm (0.02 in.) as shown in the figure.

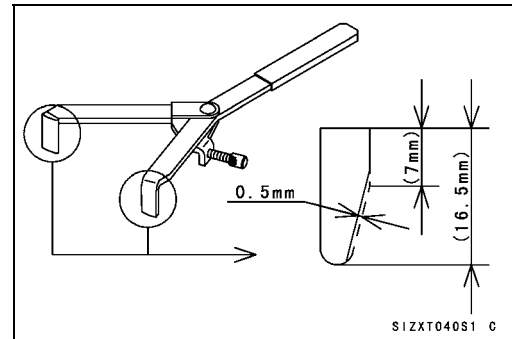

- Remove:
  - Friction Plates, Steel Plates
  - Clutch Hub Nut [A]
- Holding the sub clutch hub [B], remove the nut.

**Special Tool - Clutch Holder [C]: 57001-1243**

- Remove:
  - Torque Limiter Springs
  - Sub Clutch Hub
  - Clutch Hub
  - Spacer
- Using the two 4 mm (0.16 in.) screws [A], pull out the sleeve [B], needle bearing [C] and clutch housing [D].
- Remove the spacer.

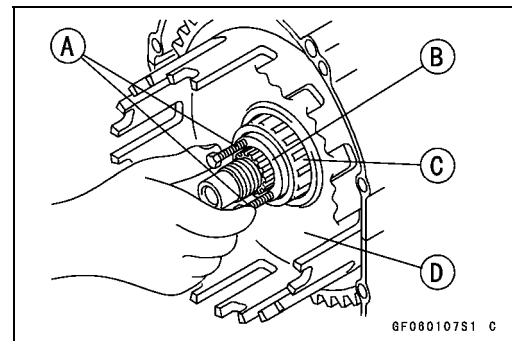

**Clutch**

*Clutch Installation*

- Install the following parts on the drive shaft.
  - Spacer [A]
  - Needle Bearing [B]
  - Sleeve [C]
  - Clutch Housing [D]
  - Spacer [E]
  - Clutch Hub [F]
  - Sub Clutch Hub [G]
  - Torque Limiter Springs [H]
  - Nut [I]

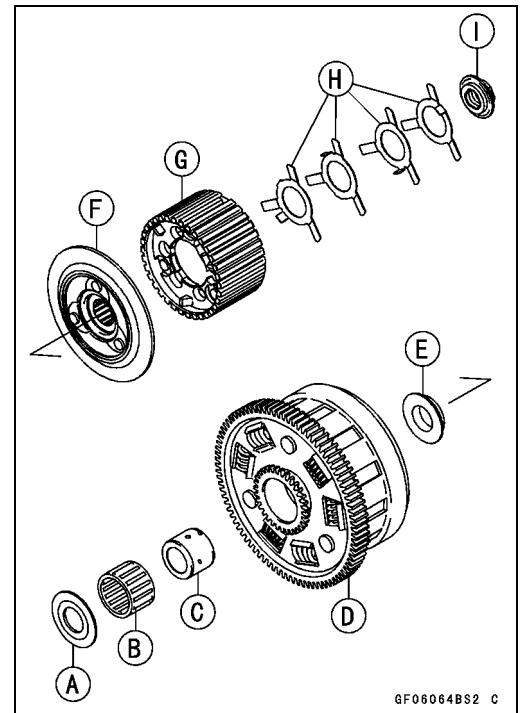

- Install the spacer [A] so that the stepped side [B] faces inward.

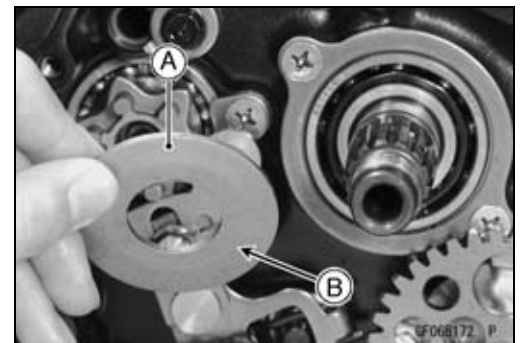

- If the clutch housing is replaced with a new one, select the proper clutch housing in accordance with the combination of the clutch housing gear and gear assembly (alternator) markings.

- Gear Assembly (Alternator) [A]
  - Clutch Housing Gear [B]

- Be sure to confirm the marking on the clutch housing gear.

**Clutch Housing Gear Selection when Replacing Clutch Housing Gear**

Gear Assembly (Alternator ) Marking [D]	Clutch Housing	
	Gear Marking (Left) [C]	Part Number
A	A	13095-0031
B	B	13095-0032
C	C	13095-0034
D	D	13095-0035
None	None	13095-0033

**NOTE**

○ If the selection mark is missing or not selection, refer to the selection section in the specifications of the Crankshaft/Transmission chapter.

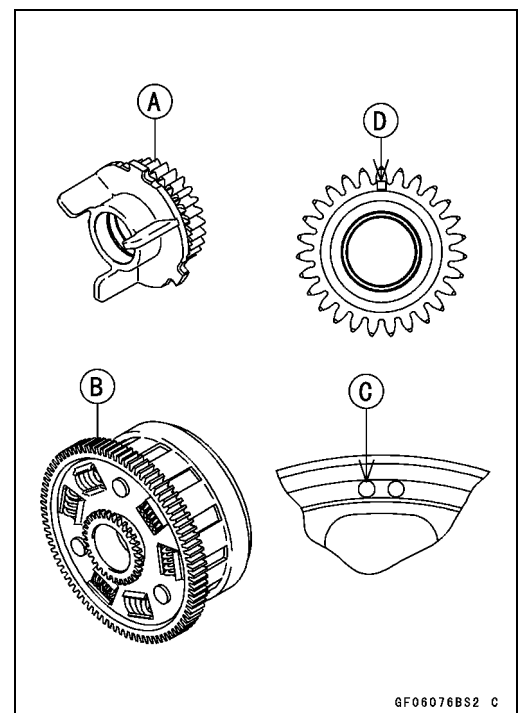

# 6-12 CLUTCH

## Clutch

- Engage the clutch housing gear [A] with the oil pump gear, gear assembly [B] and crankshaft gear [C].

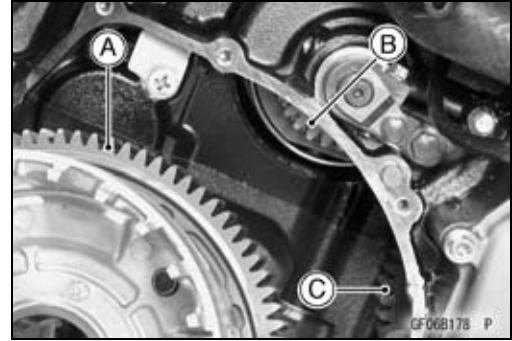

- If the clutch housing is replaced with a new one, select the proper clutch housing in accordance with the combination of the clutch housing gear marking and needle bearing.
  - Clutch Housing Gear [A]
- Be sure to confirm the marking on the clutch housing gear.

### Clutch Housing Gear and Needle Bearing Selection

Clutch Housing Gear Marking (Right) [B]	Needle Bearing	
	Size Color	Part Number
1	White	92046-0010
2	Blue	92046-0011
3	Red	92046-1263

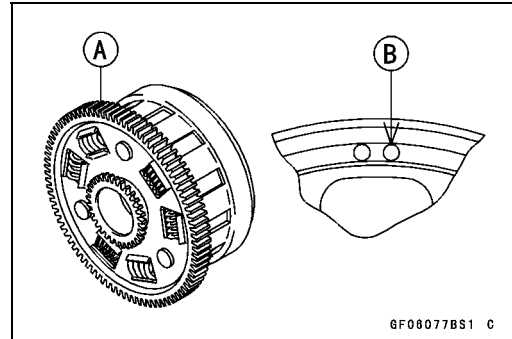

- Install the needle bearing and sleeve.
- Install the four torque limiter springs [A] as shown.

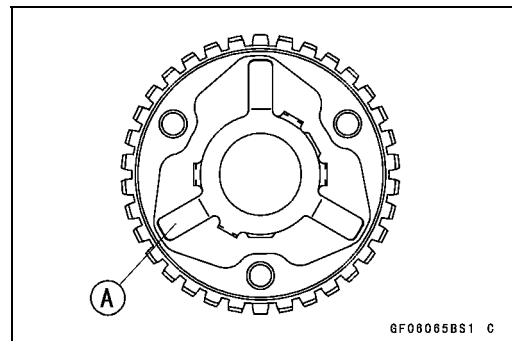

- Replace the clutch hub nut with a new one.
- Holding the sub clutch hub, tighten the clutch hub nut.

**Special Tool - Clutch Holder: 57001-1243**

**Torque - Clutch Hub Nut: 130 N·m (13 kgf·m, 96 ft·lb)**

## Clutch

○First spring plate assy [A] is thick.

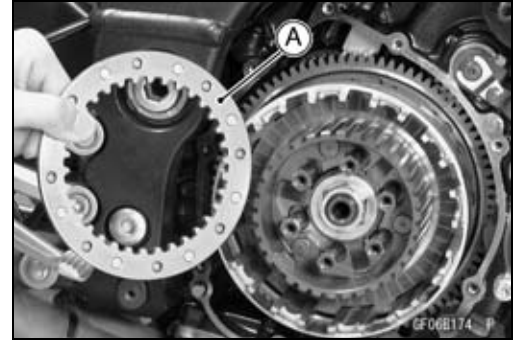

- Install the friction plates and steel plates, starting with a friction plate and alternating them.

### CAUTION

**If new dry friction plates and steel plates are installed, apply engine oil to the surfaces of each plate to avoid clutch plate seizure.**

○Install the last friction plate [A] fitting the tangs in the grooves in the housing as shown.



- Apply molybdenum disulfide grease to the pusher ends [A] and install the bearing [B], pusher [C] in the clutch spring plate [D].

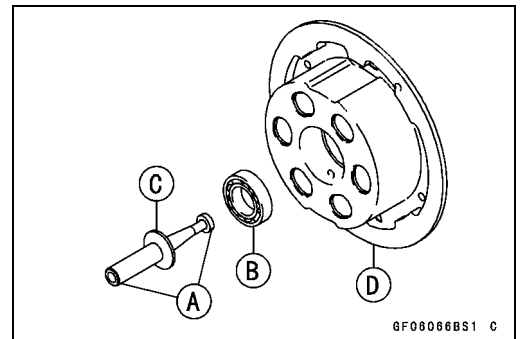

- Align the projections [A] of the spring plate [B] to the grooves [C] of the sub clutch hub [D] to install the spring plate on the sub clutch hub.
- Install the springs and spring holders, and tighten the clutch spring bolts.

**Torque - Clutch Spring Bolts: 9.8 N·m (1.0 kgf·m, 87 in·lb)**

- Install the clutch cover (see Clutch Cover Installation).

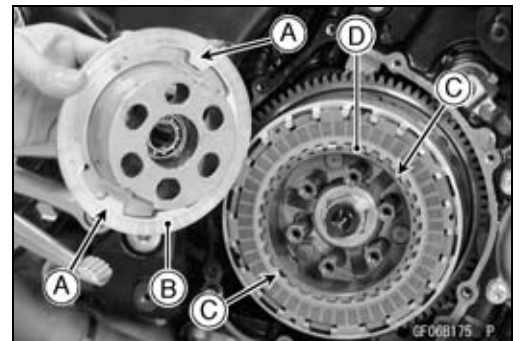

## 6-14 CLUTCH

### Clutch

#### Spring Plate Free Play Measurement

Insufficient clutch free play will cause the engine braking effect to be more sudden, resulting in rear wheel hop. On the other hand, if the free play is excessive, the clutch lever may feel “spongy” or pulsate when pulled.

- Hold an extra drive shaft in a vise and install the following clutch parts on the shaft.
  - Spacer [A]
  - Needle Bearing [B]
  - Sleeve [C]
  - Clutch Housing [D]
  - Spacer [E]
  - Clutch Hub [F]
  - Sub Clutch Hub [G]
  - Friction Plates [H]
  - Steel Plates (First Spring Plate Assy) [I]
  - Spring Plate [J]

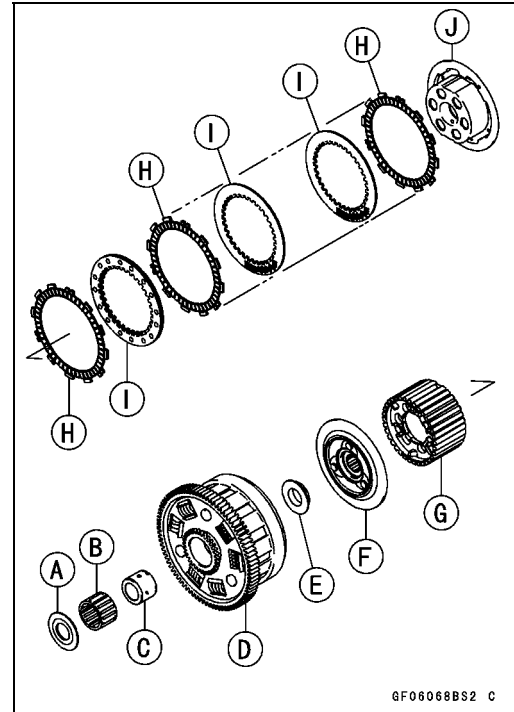

- Engage the cam followers (Clutch Hub) with the cams (Sub Clutch Hub).
  - To measure the free play, set a dial gauge [A] against the raised center [B] of the clutch spring plate.
  - Move the clutch housing gear back and forth [C]. The difference between the highest and lowest gauge readings is the amount of free play.
- Drive Shaft [D]
- Measure the spring plate free play.

#### Spring Plate Free Play

**Usable Range: 0.05 ~ 0.35 mm (0.002 ~ 0.014 in.)**

- ★ If the free play is not within the usable range, change all of the friction plate.

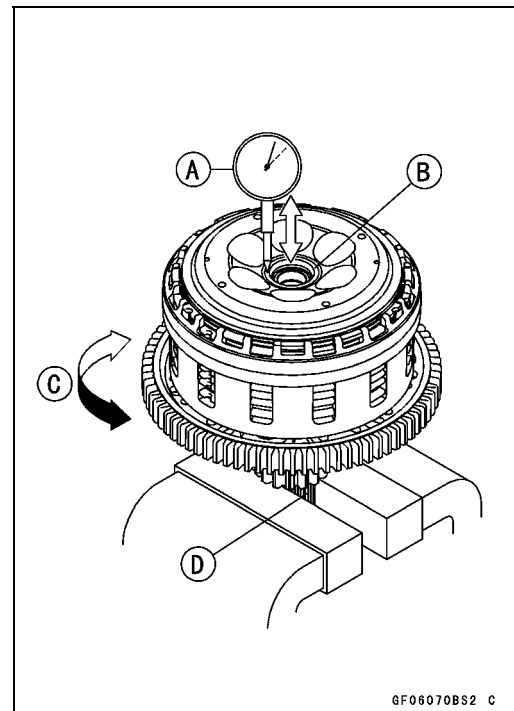



**Clutch**

*Spring Plate Play Adjustment*

- Apply a non-permanent locking agent to the thread of sub clutch hub bolts.
- Assemble the following parts so that the clutch plate assembly length [A] is specified length.
  - Clutch Hub [B]
  - Sub Clutch Hub [C]
  - Sub Clutch Hub Bolts [D]
  - Friction Plates [E]
  - Steel Plates (First Spring Plate Assy) [F]
  - Spring Plate [G]
  - Springs [H]
  - Spring Holders [I]
  - Spring Bolts [J]
- Replace the following steel plate(s).

Part Number	Thickness
13089-1084	2.3 mm (0.090 in.)
13089-1115	2.6 mm (0.102 in.) (STD)
13089-1093	2.9 mm (0.114 in.)

**NOTE**

○ Do not use the steel plate of 2.3 mm (0.090 in.) and 2.9 mm (0.114 in.) thickness at the same time.

**Torque - Sub Clutch Hub Bolts: 11 N·m (1.1 kgf·m, 95 in·lb)**  
**Clutch Spring Bolts: 9.8 N·m (1.0 kgf·m, 87 in·lb)**

**Clutch Plate Assembly**

**Standard: 53.6 mm (2.11 in.)**

*Clutch Plate, Wear, Damage Inspection*

- Visually inspect the friction and steel plates for signs of seizure, overheating (discoloration), or uneven wear.
- Measure the thickness of each friction plate [A] at several points.
- ★ If any plates show signs of damage, or if they have worn past the service limit, replace them with new ones.

**Friction Plate Thickness**

**Standard: 2.72 ~ 2.88 mm (0.107 ~ 0.113 in.)**

**Service Limit: 2.6 mm (0.102 in.)**

*Clutch Plate Warp Inspection*

- Place each friction plate or steel plate on a surface plate and measure the gap between the surface plate [A] and each friction plate or steel plate [B] with a thickness gauge [C]. The gap is the amount of friction or steel plate warp.
- ★ If any plate is warped over the service limit, replace it with a new one.

**Friction and Steel Plate Warp**

**Standard: 0.2 mm (0.008 in.) or less**

**Service Limit: 0.3 mm (0.012 in.)**

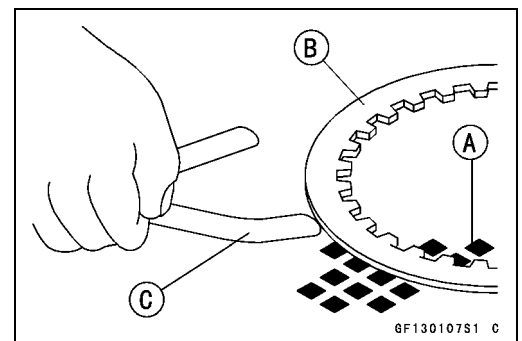
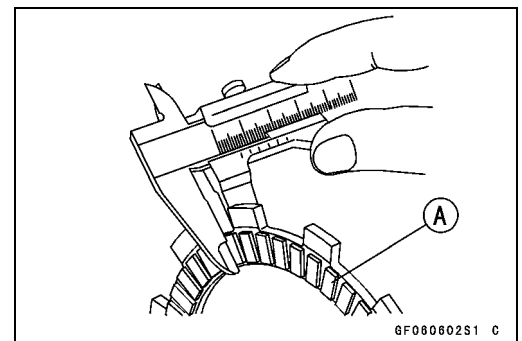
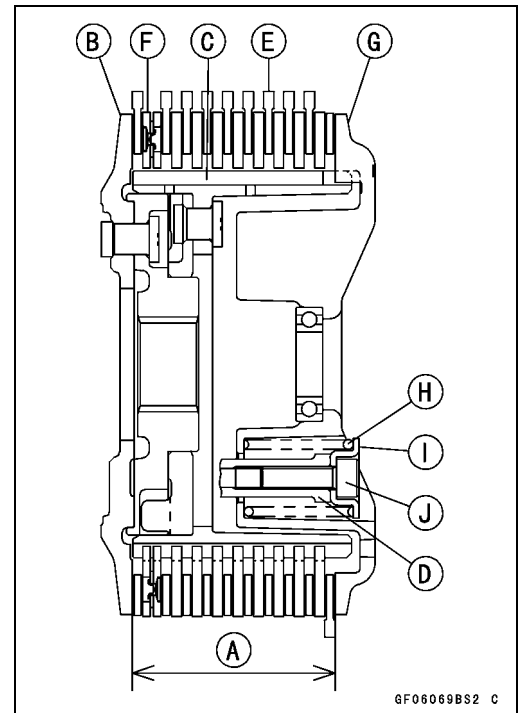

## 6-16 CLUTCH

### Clutch

#### *Clutch Spring Free Length Measurement*

- Measure the free length of the clutch springs [A].
- ★ If any spring is shorter than the service limit, it must be replaced.

#### **Clutch Spring Free Length**

**Standard:** 43.5 mm (1.71 in.)

**Service Limit:** 42.1 mm (1.66 in.)

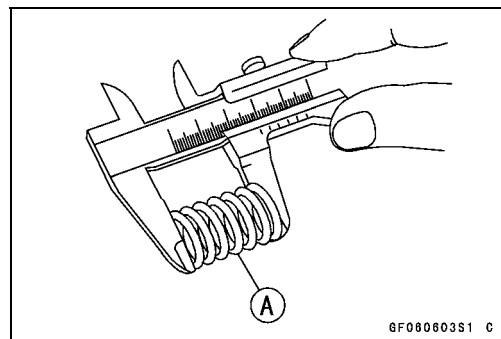

#### *Damper Cam Inspection*

- Remove the clutch (see Clutch Removal).
- Visually inspect the damper cam [A], cam follower [B], and the torque limiter spring [C].
- Replace the part if it appears damaged.

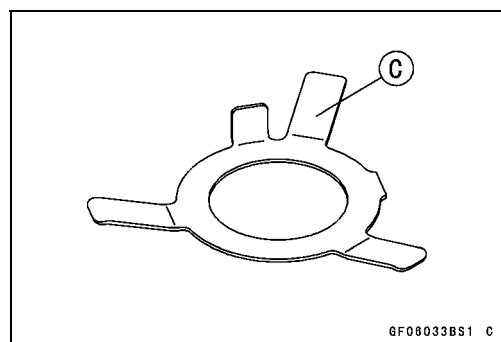
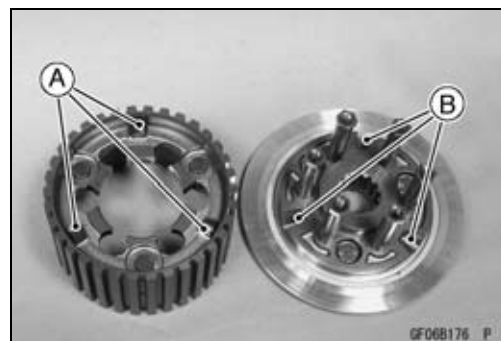

# Engine Lubrication System

## Table of Contents

Exploded View.....	7-2
Engine Oil Flow Chart.....	7-4
Specifications .....	7-5
Special Tools and Sealant.....	7-6
Engine Oil and Oil Filter.....	7-7
Oil Level Inspection.....	7-7
Engine Oil Change.....	7-7
Oil Filter Replacement .....	7-7
Oil Pan.....	7-8
Oil Pan Removal.....	7-8
Oil Pan Installation.....	7-8
Oil Pressure Relief Valve.....	7-9
Oil Pressure Relief Valve Removal.....	7-9
Oil Pressure Relief Valve Installation.....	7-9
Oil Pressure Relief Valve Inspection.....	7-9
Oil Pump.....	7-10
Oil Pump Removal.....	7-10
Oil Pump Installation.....	7-10
Oil Pump Drive Gear Removal.....	7-11
Oil Pump Drive Gear Installation.....	7-11
Oil Cooler.....	7-12
Oil Cooler Removal.....	7-12
Oil Cooler Installation.....	7-12
Oil Pressure Measurement.....	7-13
Oil Pressure Measurement .....	7-13
Oil Pressure Switch.....	7-14
Oil Pressure Switch Removal.....	7-14
Oil Pressure Switch Installation .....	7-14

# 7-2 ENGINE LUBRICATION SYSTEM

## Exploded View

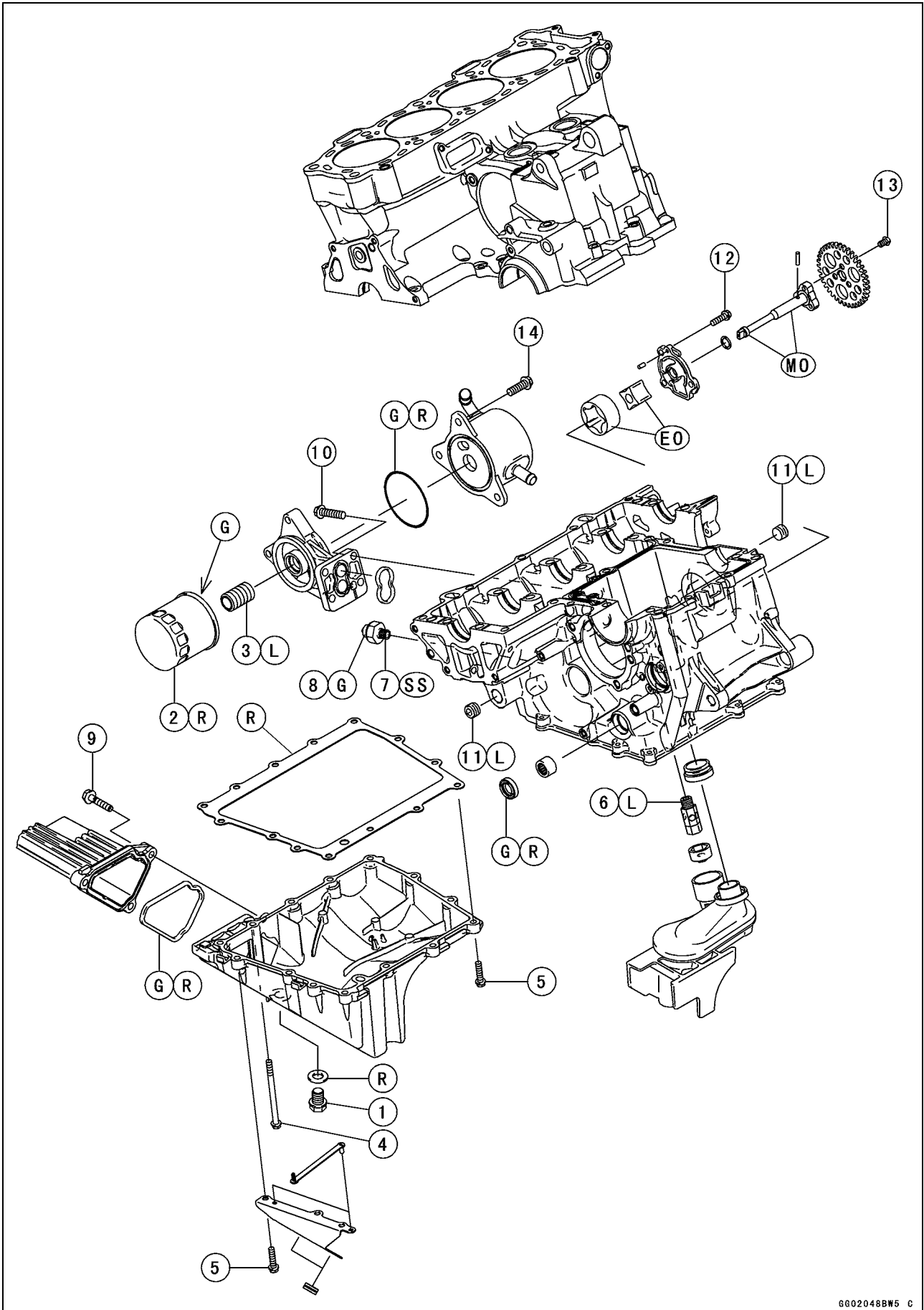

## ENGINE LUBRICATION SYSTEM 7-3

### Exploded View

No.	Fastener	Torque			Remarks
		N·m	kgf·m	ft·lb	
1	Engine Oil Drain Bolt	20	2.0	14	
2	Oil Filter	31	3.2	23	G, R
3	Holder Mounting Bolt	35	3.6	26	L
4	Oil Pan Bolt (M6, L = 85 mm)	9.8	1.0	87 in·lb	
5	Oil Pan Bolts (M6, L = 25 mm)	9.8	1.0	87 in·lb	
6	Oil Pressure Relief Valve	15	1.5	11	L
7	Oil Pressure Switch	15	1.5	11	SS
8	Oil Pressure Switch Terminal Bolt	1.5	0.15	13 in·lb	
9	Sub Oil Pan Bolts	25	2.5	18	
10	Oil Filter Case Mounting Bolts	20	2.0	14	
11	Oil Passage Plugs	20	2.0	14	L
12	Oil Pump Cover Bolts	9.8	1.0	87 in·lb	
13	Oil Pump Drive Gear Bolts	9.8	1.0	87 in·lb	
14	Oil Cooler Mounting Bolts	20	2.0	14	

EO: Apply engine oil.

G: Apply grease.

L: Apply a non-permanent locking agent.

MO: Apply molybdenum disulfide oil.

(mixture of the engine oil and molybdenum disulfide grease in a weight ratio 10 : 1)

R: Replacement Parts

SS: Apply silicone sealant (Kawasaki Bond: 56019-120).

# 7-4 ENGINE LUBRICATION SYSTEM

## Engine Oil Flow Chart

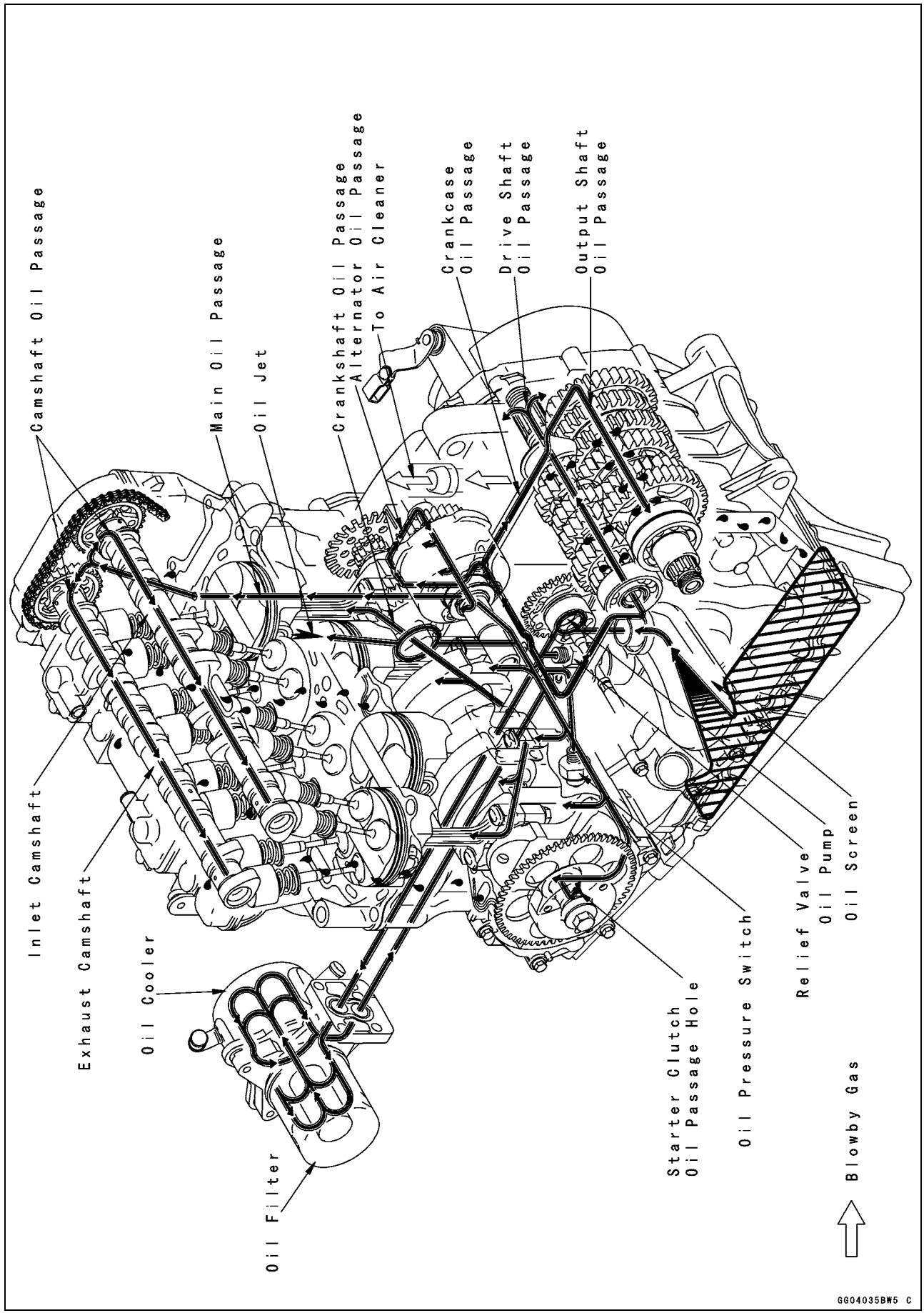

## ENGINE LUBRICATION SYSTEM 7-5

### Specifications

Item	Standard
<b>Engine Oil</b> Type  Viscosity Capacity  Level	API SE, SF or SG API SH or SJ with JASO MA SAE 10W-40 2.7 L (2.9 US qt) (when filter is not removed) 3.0 L (3.2 US qt) (when filter is removed) 3.7 L (3.9 US qt) (when engine is completely dry) Between upper and lower level lines
<b>Oil Pressure Measurement</b> Oil Pressure @4 000 r/min (rpm), Oil Temperature 90°C (194°F)	150 ~ 230 kPa (1.5 ~ 2.4 kgf/cm <sup>2</sup> , 22 ~ 33 psi)

# 7-6 ENGINE LUBRICATION SYSTEM

## Special Tools and Sealant

**Oil Pressure Gauge, 10 kgf/cm<sup>2</sup>:**  
**57001-164**

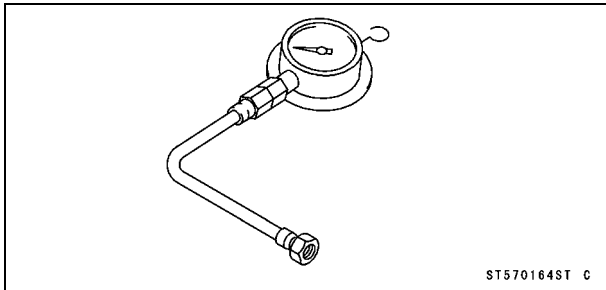

**Gear Holder:**  
**57001-1599**

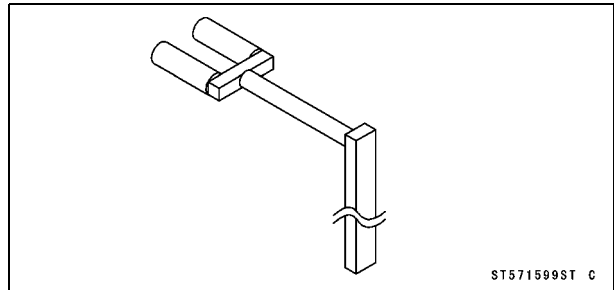

**Oil Pressure Gauge Adapter, PT3/8 × 19/in.:**  
**57001-1233**

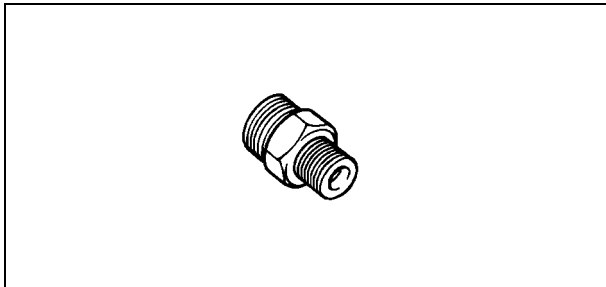

**Kawasaki Bond (Silicone Sealant):**  
**56019-120**

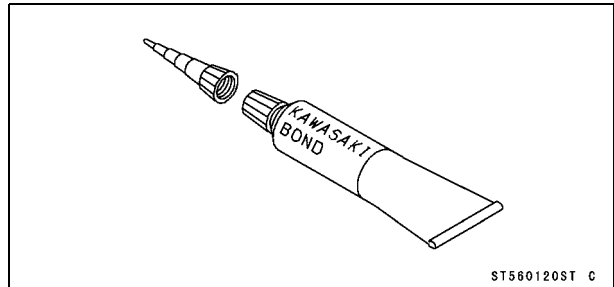

**Oil Filter Wrench:**  
**57001-1249**

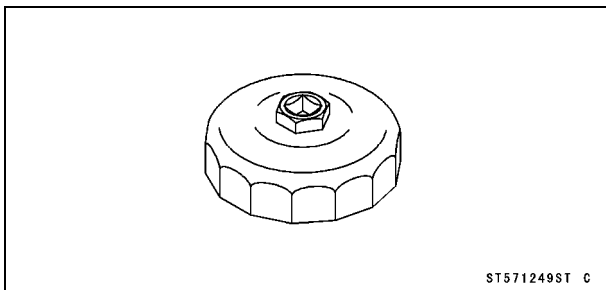



## Engine Oil and Oil Filter

### **⚠ WARNING**

Motorcycle operation with insufficient, deteriorated, or contaminated engine oil will cause accelerated wear and may result in engine or transmission seizure, accident, and injury.

#### *Oil Level Inspection*

- Check that the engine oil level is between the upper [A] and lower [B] levels in the gauge.

#### **NOTE**

- Situate the motorcycle so that it is perpendicular to the ground.
- If the motorcycle has just been used, wait several minutes for all the oil to drain down.
- If the oil has just been changed, start the engine and run it for several minutes at idle speed. This fills the oil filter with oil. Stop the engine, then wait several minutes until the oil settles.

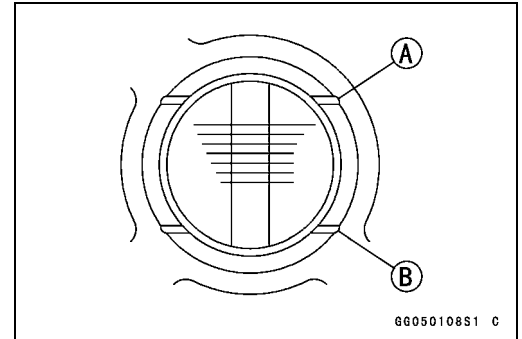

### **CAUTION**

Racing the engine before the oil reaches every part can cause engine seizure.

If the engine oil gets extremely low or if the oil pump or oil passages clog up or otherwise do not function properly, the oil pressure warning light will light. If this light stays on when the engine is running above idle speed, stop the engine immediately and find the cause.

#### *Engine Oil Change*

- Refer to the Engine Oil Change in the Periodic Maintenance chapter.

#### *Oil Filter Replacement*

- Refer to the Oil Filter Replacement in the Periodic Maintenance chapter.

## 7-8 ENGINE LUBRICATION SYSTEM

### Oil Pan

#### Oil Pan Removal

- Remove:
  - Engine Oil (Drain, see Engine Oil Change in the Periodic Maintenance chapter)
  - Exhaust Pipe Assy and Muffler Body (see Engine Top End chapter)
  - Oil Pan Bolts [A]
  - Oil Pan [B]

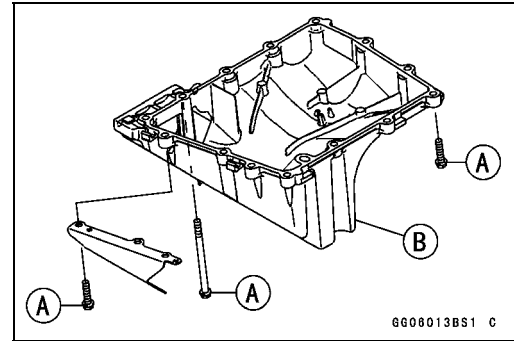

- Remove the oil screen and oil pressure relief valve [A] as necessary.



#### Oil Pan Installation

- Clean the oil screen [A].
- Install the oil screen so that the crankcase rib [B] and relief valve [C] fits the oil screen.
- ★ If the oil pressure relief valve was removed, install it.
- Apply a non-permanent locking agent to the threads of the oil pressure relief valve, and tighten it.

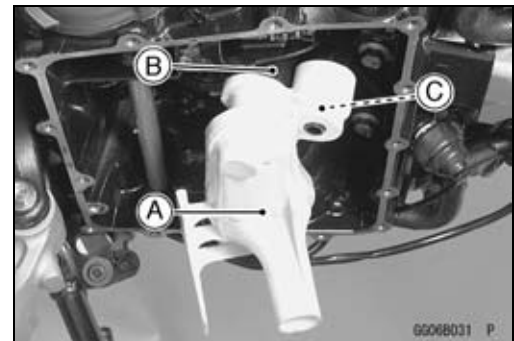

#### CAUTION

**Do not apply too much non-permanent locking agent to the threads. This may block the oil passage.**

**Torque - Oil Pressure Relief Valve: 15 N·m (1.5 kgf·m, 11 ft·lb)**

- Install the bracket [A] as shown.
- Replace the oil pan gasket with a new one.
- Tighten:
  - Torque - Oil Pan Bolts (M6, L = 25 mm) [B]: 9.8 N·m (1.0 kgf·m, 87 in·lb)**
  - Oil Pan Bolt (M6, L = 85 mm) [C]: 9.8 N·m (1.0 kgf·m, 87 in·lb)**
  - Sub Oil Pan Bolts: 25 N·m (2.5 kgf·m, 18 ft·lb)**

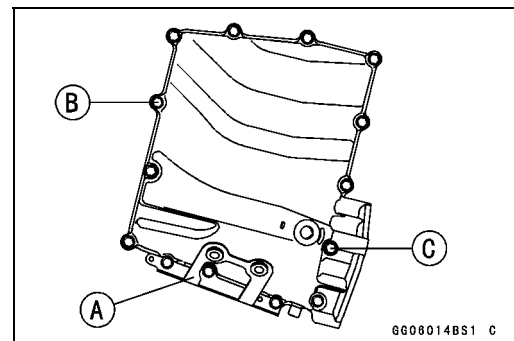

## Oil Pressure Relief Valve

### Oil Pressure Relief Valve Removal

- See Oil Pan Removal.

### Oil Pressure Relief Valve Installation

- See Oil Pan Installation.

### Oil Pressure Relief Valve Inspection

- Check to see if the valve [A] slides smoothly when pushing it in with a wooden or other soft rod, and see if it comes back to its seat by spring [B] pressure.

#### NOTE

○ *Inspect the valve in its assembled state. Disassembly and assembly may change the valve performance.*

- ★ If any rough spots are found during above inspection, wash the valve clean with a high-flash point solvent and blow out any foreign particles that may be in the valve with compressed air.

#### **⚠ WARNING**

**Clean the oil pressure relief valve in a well-ventilated area, and take care that there is no spark or flame anywhere near the working area. Because of the danger of highly flammable liquids, do not use gasoline or low-flash point solvent.**

- ★ If cleaning does not solve the problem, replace the oil pressure relief valve as an assembly. The oil pressure relief valve is precision made with no allowance for replacement of individual parts.

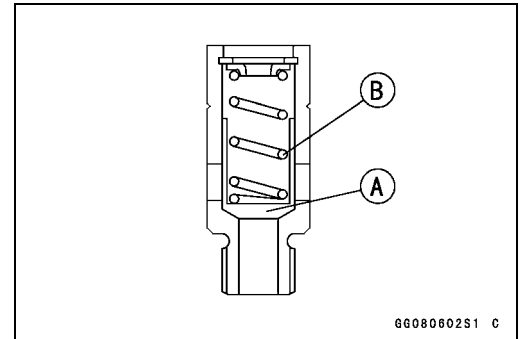

## 7-10 ENGINE LUBRICATION SYSTEM

### Oil Pump

#### Oil Pump Removal

- Drain:
  - Coolant (see Coolant Change in the Periodic Maintenance chapter)
  - Engine Oil (see Engine Oil Change in the Periodic Maintenance chapter)
- Remove:
  - Clutch (see Clutch chapter)
- Holding the oil pump drive gear [A], remove the bolts [B].  
**Special Tool - Gear Holder [C]: 57001-1599**

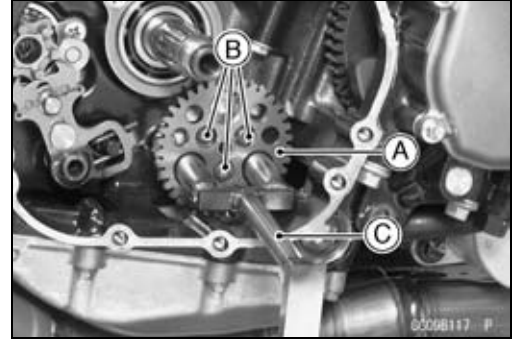

- Remove the oil pump cover bolts [A].
- Remove the oil pump cover [B] with oil pump shaft.
- Remove the outer rotor and inner rotor.

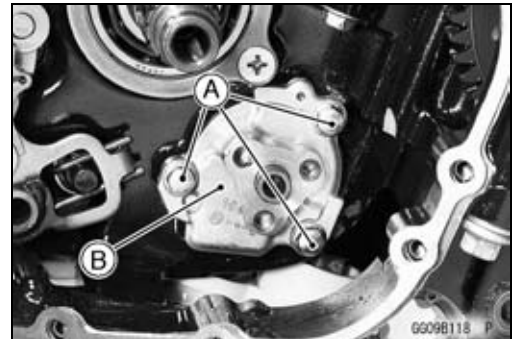

#### Oil Pump Installation

- Apply molybdenum disulfide oil solution to the journal portions [A] on the oil pump drive gear shaft [B].

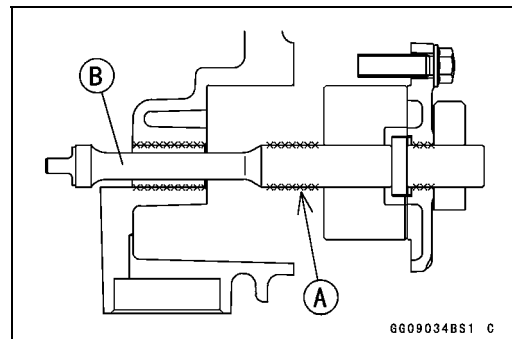

- Install the outer rotor [A] into the crankcase.
- Install the oil pump cover, pin and inner rotor to the oil pump shaft [B].
- Turn the pump shaft so that the projection [C] in its shaft fits onto the slot [D] of the oil pump drive gear shaft.
- Fit the pin of the oil pump cover into the hole in the crankcase.

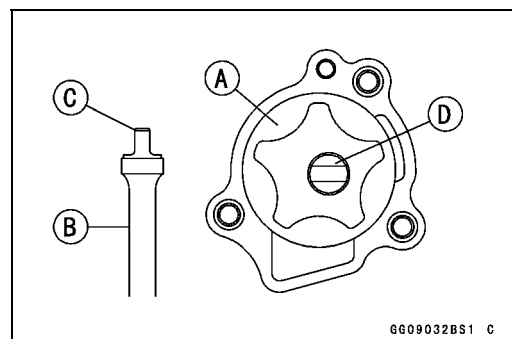

### Oil Pump

- Tighten:  
**Torque - Oil Pump Cover Bolts [A]: 9.8 N·m (1.0 kgf·m, 87 in·lb)**

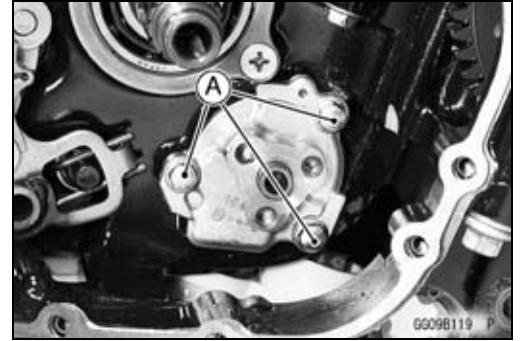

- Holding the oil pump drive gear [A], tighten the bolts [B].  
**Special Tool - Gear Holder: 57001-1599**  
**Torque - Oil Pump Drive Gear Bolts: 9.8 N·m (1.0 kgf·m, 87 in·lb)**

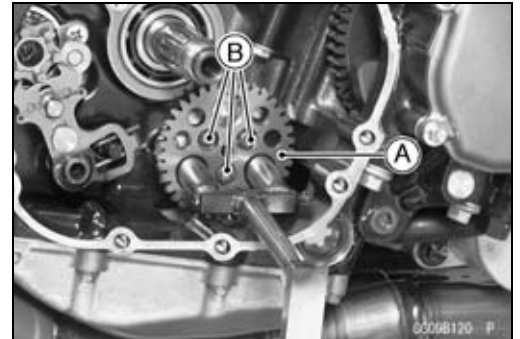

#### *Oil Pump Drive Gear Removal*

- See Oil Pump Removal.

#### *Oil Pump Drive Gear Installation*

- See Oil Pump Installation.

## 7-12 ENGINE LUBRICATION SYSTEM

### Oil Cooler

#### Oil Cooler Removal

- Remove:
  - Lower Fairing (see Frame chapter)
- Drain:
  - Coolant (see Coolant Change in the Periodic Maintenance chapter)
  - Engine Oil (see Engine Oil Change in the Periodic Maintenance chapter)
- Remove the water hoses [A] from the oil cooler.
- Unscrew the oil cooler mounting bolts [B], and remove the oil cooler [C].

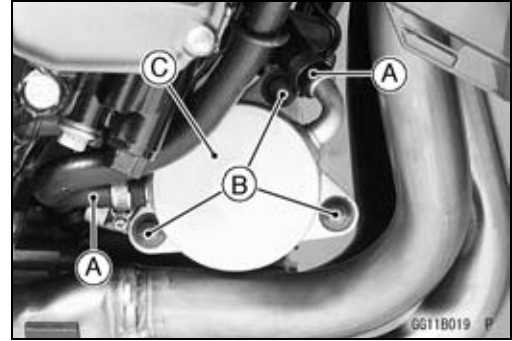

#### Oil Cooler Installation

- Apply grease to the O-ring [A] before installation.

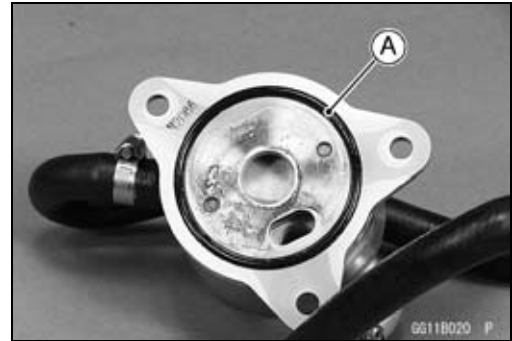

- Install the oil cooler to the oil cooler case, and tighten the bolts.

**Torque - Oil Cooler Mounting Bolts: 20 N·m (2.0 kgf·m, 14 ft·lb)**

- Install the water hoses as shown.

White Mark [A]

- Tighten:

**Torque - Water Hose Clamp Screws: 2.0 N·m (0.20 kgf·m, 18 in·lb)**

- Pour:

Engine Oil (see Engine Oil Change in the Periodic Maintenance chapter)

Coolant (see Coolant Change in the Periodic Maintenance chapter)

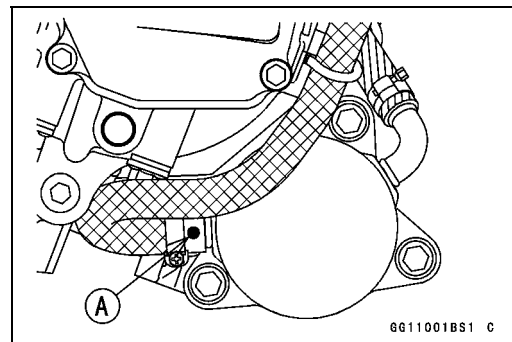

## Oil Pressure Measurement

### Oil Pressure Measurement

- Remove the lower fairing (see Frame chapter).
- Remove the oil passage plug, and attach the adapter [A] and gauge [B] to the plug hole.

**Special Tools - Oil Pressure Gauge, 10 kgf/cm<sup>2</sup>: 57001-164**  
**Oil Pressure Gauge Adapter, PT3/8 × 19/in.: 57001-1233**

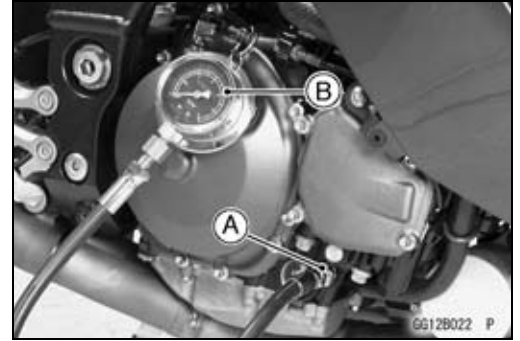

- Start the engine and warm up the engine.
- Run the engine at the specified speed, and read the oil pressure gauge.
- ★ If the oil pressure is much lower than the standard, check the oil pump, relief valve, and/or crankshaft bearing insert wear immediately.
- ★ If the reading is much higher than the standard, check the oil passages for clogging.

### Oil Pressure

**Standard:** 150 ~ 230 kPa (1.5 ~ 2.4 kgf/cm<sup>2</sup>, 22 ~ 33 psi) @ 4 000 r/min (rpm), oil temperature 90°C (194°F)

- Stop the engine.
- Remove the oil pressure gauge and adapter.

### **⚠ WARNING**

**Take care against burns from hot engine oil that will drain through the oil passage when the gauge adapter is removed.**

- Apply a non-permanent locking agent to the oil passage plug, and install it.

**Torque - Oil Passage Plug (Right): 20 N·m (2.0 kgf·m, 14 ft·lb)**

## 7-14 ENGINE LUBRICATION SYSTEM

### Oil Pressure Switch

#### Oil Pressure Switch Removal

- Remove:
  - Engine Oil (Drain, see Engine Oil Change in the Periodic Maintenance chapter)
  - Upper Fairing (see Frame chapter)
  - Exhaust Pipe Assy and Muffler Body (see Engine Top End chapter)
  - Switch Cover [A]
  - Switch Terminal [B]
  - Oil Pressure Switch [C]

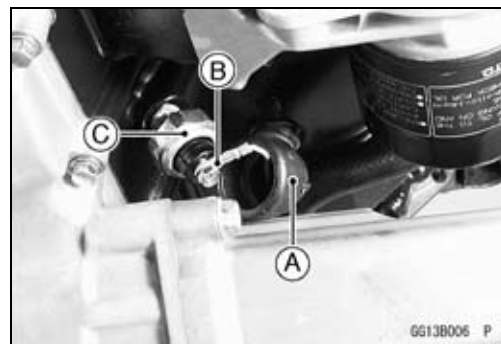

#### Oil Pressure Switch Installation

- Apply silicone sealant to the threads of the oil pressure switch and tighten it.
  - Sealant - Kawasaki Bond (Silicone Sealant): 56019-120**
  - Torque - Oil Pressure Switch: 15 N·m (1.5 kgf·m, 11 ft·lb)**
- Install the switch lead direction [A] upward.
- Apply grease to the terminal.
- Tighten the terminal bolt.
  - Torque - Oil Pressure Switch Terminal Bolt: 1.5 N·m (0.15 kgf·m, 13 in·lb)**

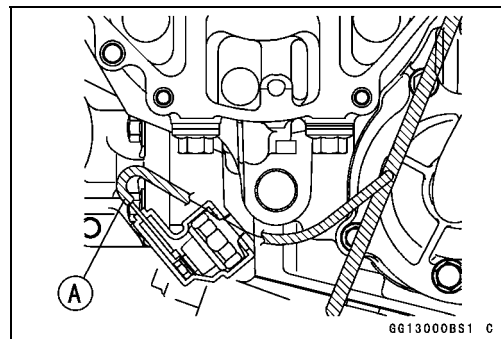



# Engine Removal/Installation

## Table of Contents

Exploded View.....	8-2
Special Tool .....	8-4
Engine Removal/Installation.....	8-5
Engine Removal.....	8-5
Engine Installation.....	8-7

# 8-2 ENGINE REMOVAL/INSTALLATION

## Exploded View

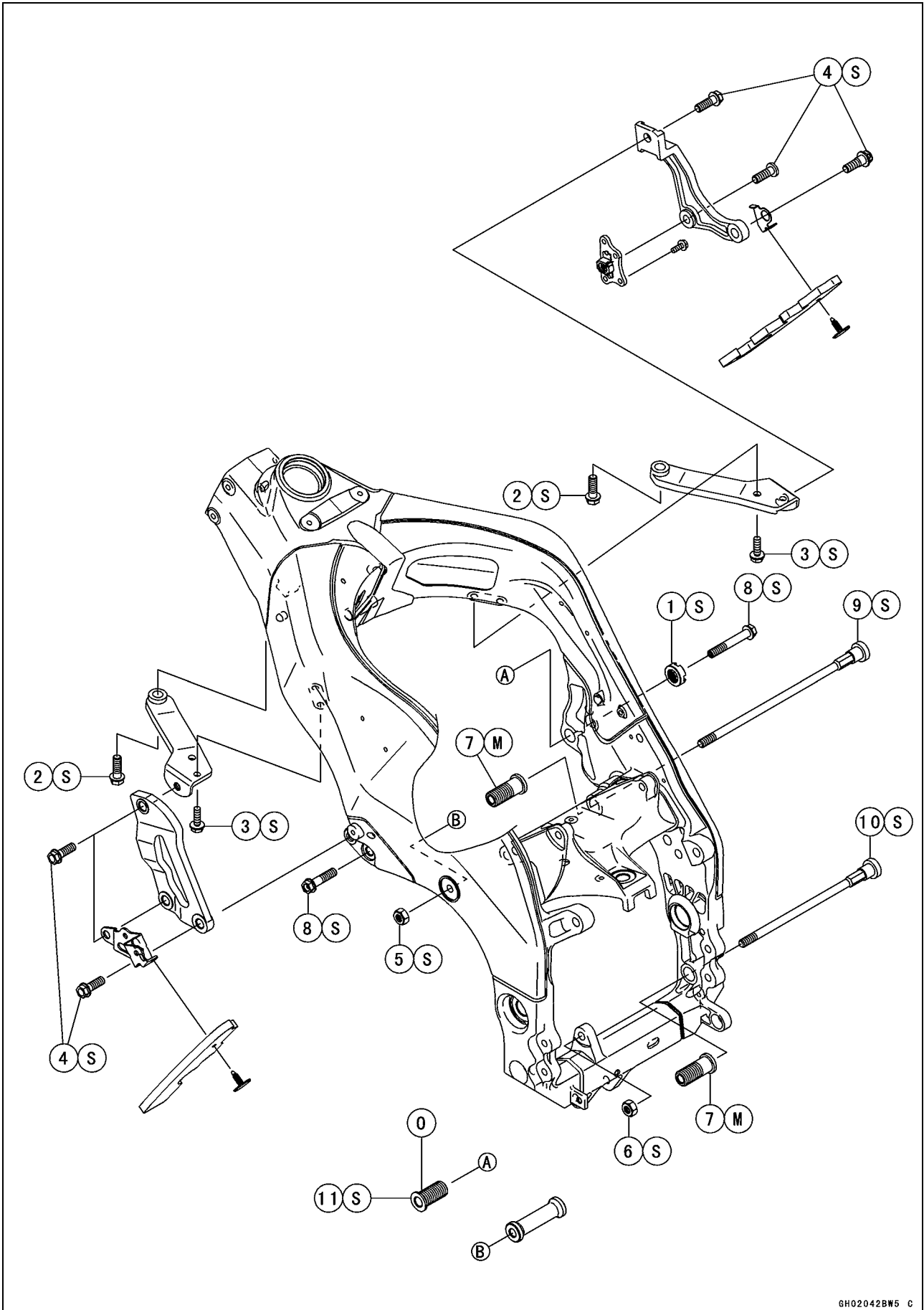

## ENGINE REMOVAL/INSTALLATION 8-3

### Exploded View

No.	Fastener	Torque			Remarks
		N·m	kgf·m	ft·lb	
1	Adjusting Collar Locknut	49	5.0	36	S
2	Upper Bracket Bolts	44	4.5	33	S
3	Upper Bracket Bolts	25	2.5	18	S
4	Engine Bracket Bolts	44	4.5	33	S
5	Middle Engine Mounting Nut	44	4.5	33	S
6	Lower Engine Mounting Nut	44	4.5	33	S
7	Engine Mounting Adjusting Bolt	9.8	1.0	87 in·lb	M, S
8	Front Engine Mounting Bolts	44	4.5	33	S
9	Middle Engine Mounting Bolt	9.8	1.0	87 in·lb	S
10	Lower Engine Mounting Bolt	9.8	1.0	87 in·lb	S
11	Engine Mounting Adjusting Bolt	9.8	1.0	87 in·lb	O, S

M: Apply molybdenum sulfide grease.

O: Apply oil.

S: Follow the specific tightening sequence.

## 8-4 ENGINE REMOVAL/INSTALLATION

---

### Special Tool

---

Engine Mount Nut Wrench:

57001-1450

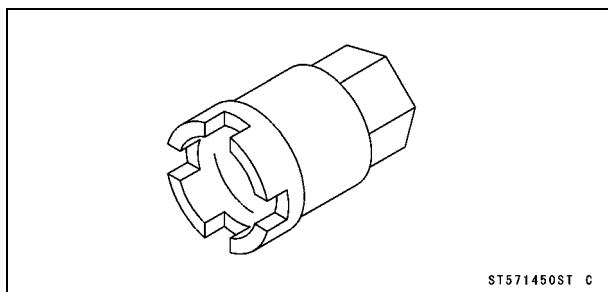

## Engine Removal/Installation

### Engine Removal

- Support the rear part of the swingarm with a stand.
- Squeeze the brake lever slowly and hold it with a band [A].

### **⚠ WARNING**

**Be sure to hold the front brake when removing the engine, or the motorcycle may fall over. It could cause an accident and injury.**

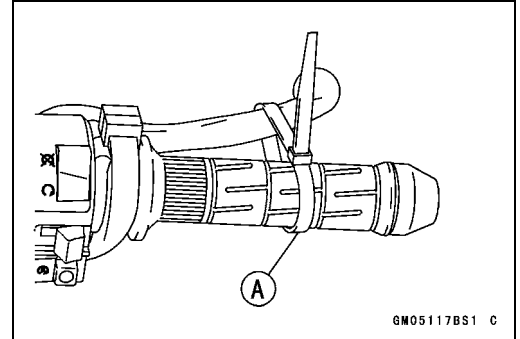

### **CAUTION**

**Be sure to hold the front brake when removing the engine, or the motorcycle may fall over. The engine or the motorcycle could be damaged.**

- Drain:
  - Engine Oil (see Engine Oil Change in the Periodic Maintenance chapter)
  - Coolant (see Coolant Change in the Periodic Maintenance chapter)
- Remove:
  - Fairings (see Frame chapter)
  - Fuel Tank (see Fuel System (DFI) chapter)
  - Air Cleaner Housing (see Fuel System (DFI) chapter)
  - Throttle Body Assembly (see Fuel System (DFI) chapter)
  - Clutch Cable Lower End (see Clutch chapter)
  - Radiator (see Cooling System chapter)
  - Exhaust Pipe Assy and Muffler Body (see Engine Top End chapter)
  - Shift Lever (see Crankshaft/Transmission chapter)
- Pull off the connectors from the engine and free the wiring from the clamps.
- Remove:
  - Sidestand Switch Lead Connector [A]
  - Speed Sensor Connector [B]
- Remove:
  - Rear Wheel (see Wheels/Tires chapter)
  - Engine Sprocket (see Final Drive chapter)
- Remove:
  - Engine Ground Cable Terminal Bolt [A]
  - Starter Motor Lead [B]

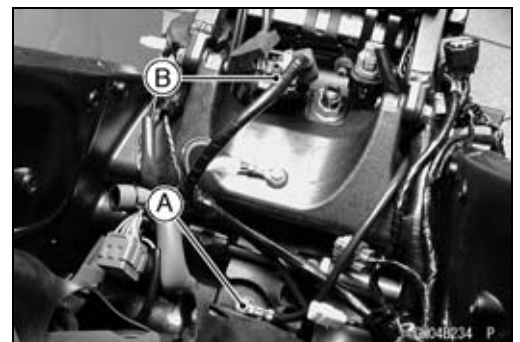
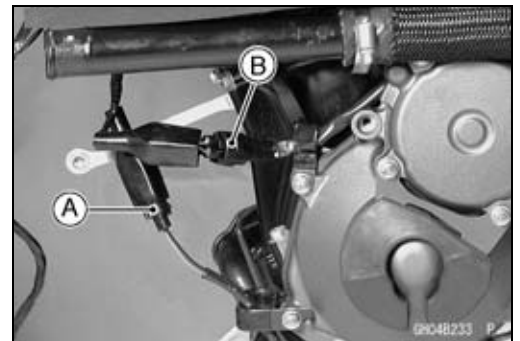

## 8-6 ENGINE REMOVAL/INSTALLATION

### Engine Removal/Installation

- Support the engine with a suitable stand [A].
- Put a plank [B] onto the suitable stand for engine balance.

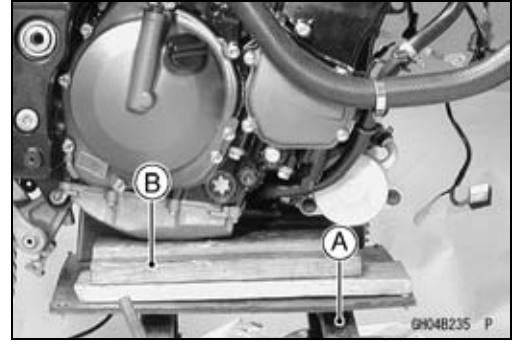

- Remove:
  - Right Engine Bracket Bolts [A]
  - Right Engine Bracket [B]

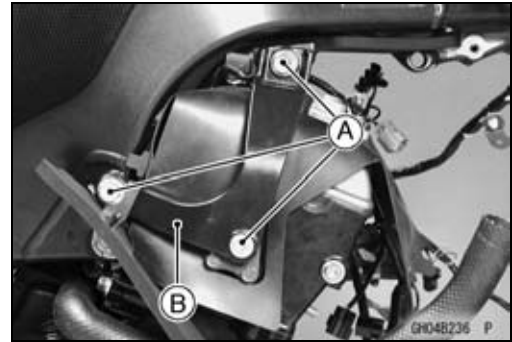

- Remove:
  - Left Engine Bracket Bolts [A]
  - Left Engine Bracket [B]
  - Left Front Engine Mounting Bolt [C]

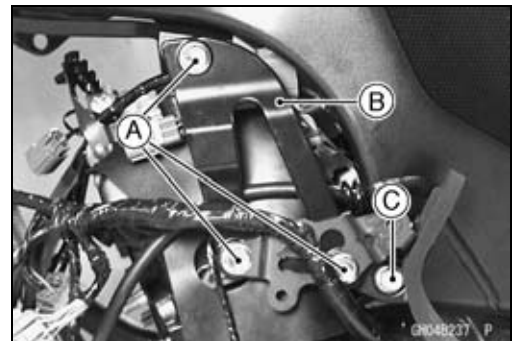

- Remove the middle and lower engine mounting nuts and bolts [A].
- Remove the right front engine mounting bolt [B].

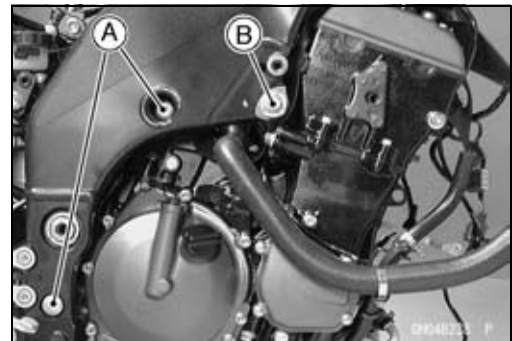

- Using the nut wrench [A], loosen the locknut [B].  
**Special Tool - Engine Mount Nut Wrench: 57001-1450**

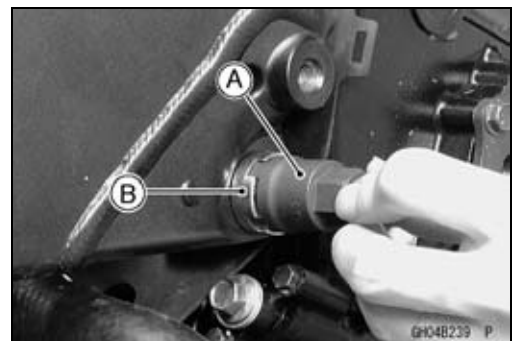

### Engine Removal/Installation

- Using the Hexagon Wrench, turn the adjusting collar [A] counterclockwise to mark the gap between the engine and frame adjusting collar.

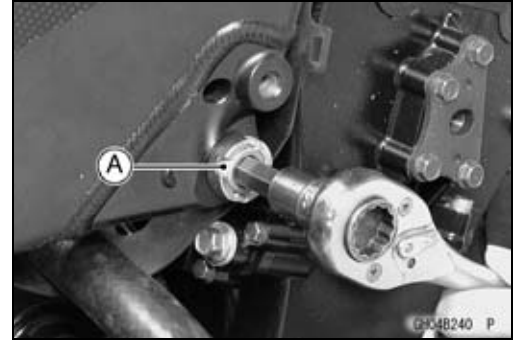

- Remove the drive chain from the output shaft.
- Using the stand, take out the engine.

#### *Engine Installation*

- Support the engine with a suitable stand.
- Put a plank onto the suitable stand for engine balance.
- Install the heat insulation rubber plate.

## 8-8 ENGINE REMOVAL/INSTALLATION

### Engine Removal/Installation

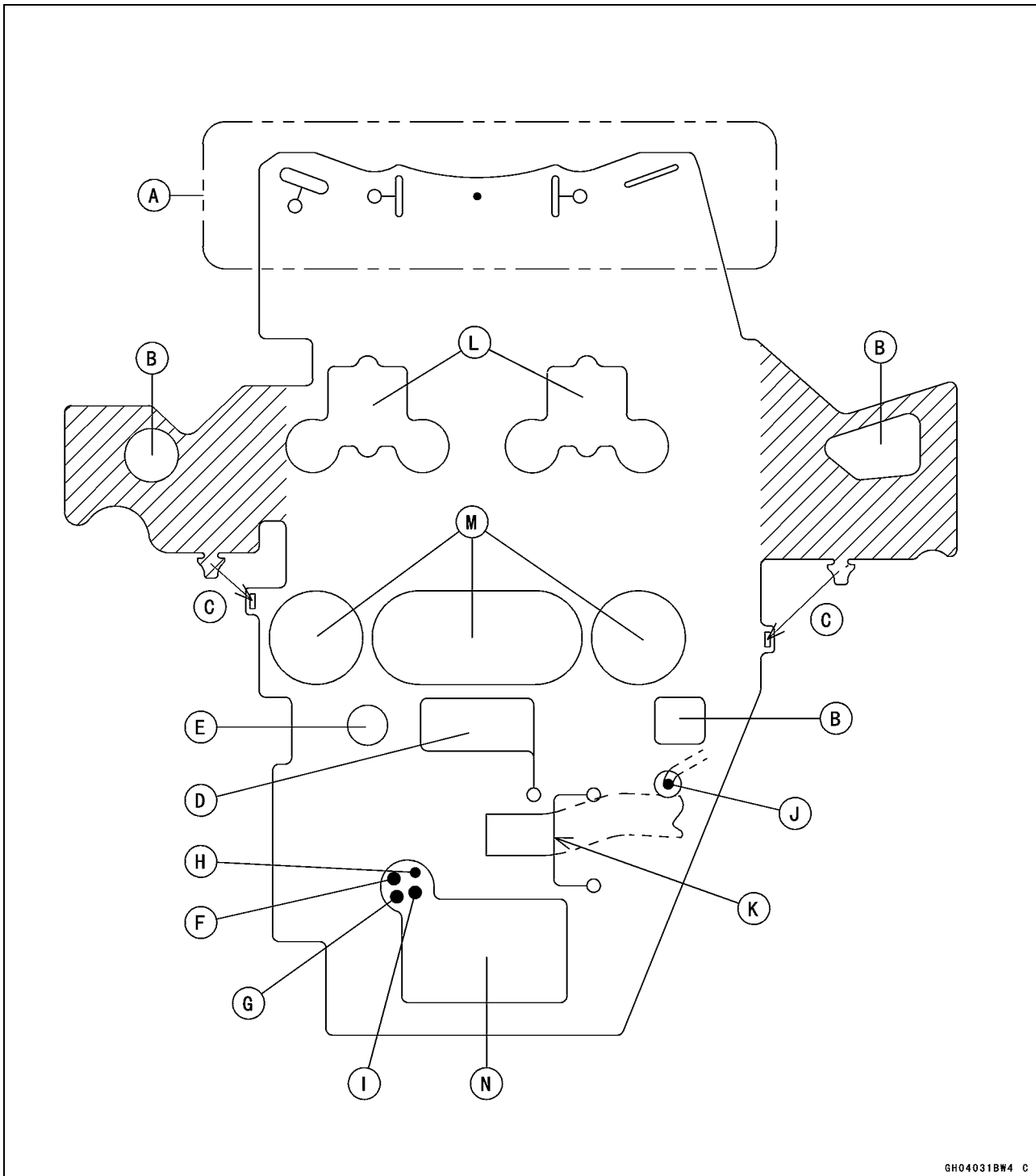

GH04031BW4 C

- A: To Radiator
- B: Through the engine mounting bolt.
- C: After installation, set the projection in the hole.
- D: To Thermostat Case
- E: To Water Temperature Sensor
- F: Idle Adjuster Cable
- G: Gear Position Sensor and Oil Pressure Lead
- H: Starter Lead
  - I: Alternator Lead
- J: Crankshaft Sensor Lead
- K: Through the water hose under the heat insulation rubber plate.
- L: To Stick Coil
- M: To Throttle Body Holder
- N: To Breather Tube, Ground Lead and Engine Mount



## Engine Removal/Installation

- Install the engine mounting bolts and nuts, following the specified installing sequence.
- Apply molybdenum disulfide grease to the thread of adjusting nuts [A] and oil to the thread of adjusting nut [D].
- First, install the adjusting nuts [A], [D] to crankcase back side upper and lower and frame.
- Crankcase [B]
- Frame [C]
- Second, hang the drive chain over the output shaft just before mounting the engine into its final position in the frame.

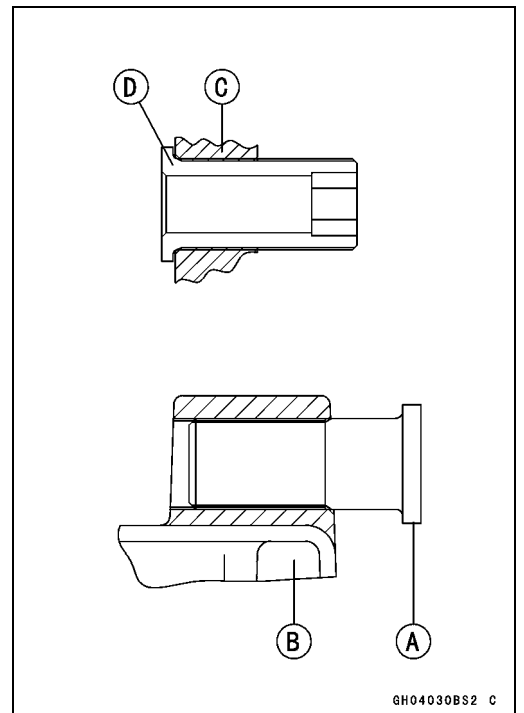
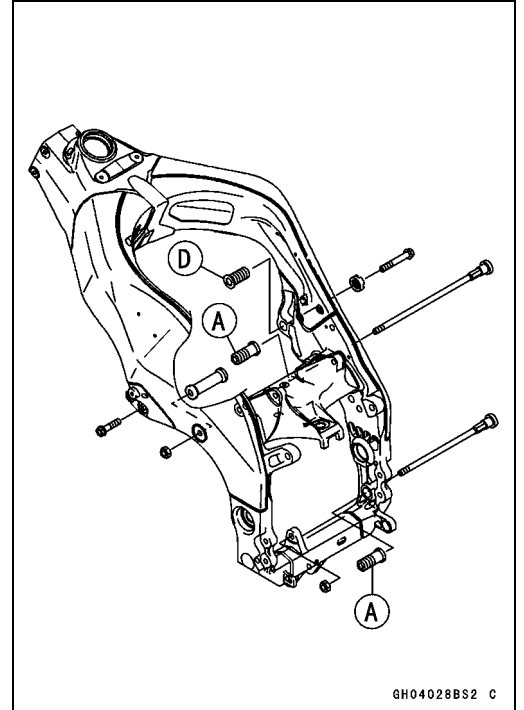

## 8-10 ENGINE REMOVAL/INSTALLATION

### Engine Removal/Installation

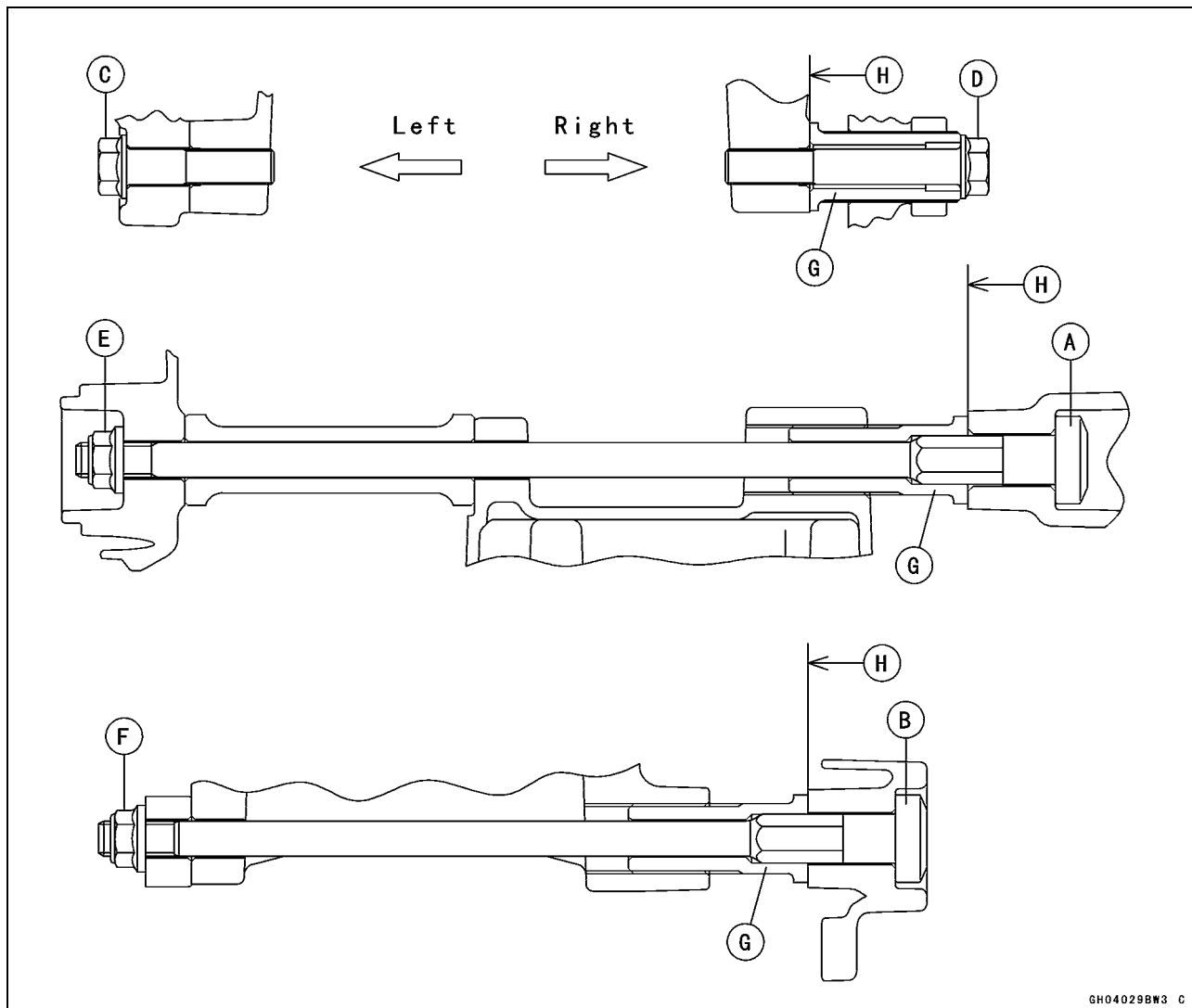

- Third, tighten the bolts [A] [B] [C] [D] temporarily, and tighten the bolt [C].

**Torque - Left Front Engine Mounting Bolt: 44 N·m (4.5 kgf·m, 33 ft·lb)**

- Fourth, install the middle [A] and lower [B] engine mounting bolts, and tighten the bolts counterclockwise.

**Torque - Middle Engine Mounting Bolt: 9.8 N·m (1.0 kgf·m, 87 in·lb)**

**Lower Engine Mounting Bolt: 9.8 N·m (1.0 kgf·m, 87 in·lb)**

- Fifth, tighten the middle [E] and lower [F] engine mounting nuts.

**Torque - Middle Engine Mounting Nut: 44 N·m (4.5 kgf·m, 33 ft·lb)**

**Lower Engine Mounting Nut: 44 N·m (4.5 kgf·m, 33 ft·lb)**

- Sixth, pull out bolt [D] temporarily, and turn the adjusting collar [G] until the clearance [H] between the cylinder head and frame come to 0 mm.

- Seventh, tighten the bolt.

**Torque - Right Front Engine Mounting Bolt: 44 N·m (4.5 kgf·m, 33 ft·lb)**

### Engine Removal/Installation

---

○ Lastly, tighten the adjusting collar locknut.

**Special Tool - Engine Mount Nut Wrench: 57001-1450**

**Torque - Adjusting Collar Locknut: 49 N·m (5.0 kgf·m, 36 ft·lb)**

- Run the leads, cable and hoses correctly (see Cable, Wire and Hose Routing section in Appendix chapter).
- Install the removed parts (see appropriate chapter).
- Adjust:
  - Throttle Cables (see Fuel System (DFI) chapter)
  - Choke Cable (see Fuel System (DFI) chapter)
  - Clutch Cable (see Clutch chapter)
  - Drive Chain (see Final Drive chapter)
- Fill the engine with engine oil (see Engine Oil Change in the Periodic Maintenance chapter).
- Fill the engine with coolant and bleed the air from the cooling system (see Coolant Change in the Periodic Maintenance chapter).



# Crankshaft/Transmission

## Table of Contents

Exploded View.....	9-2	Piston Ring, Piston Ring Groove	
Specifications .....	9-6	Wear.....	9-26
Special Tools and Sealants .....	9-9	Piston Ring Groove Width.....	9-27
Crankcase Splitting.....	9-10	Piston Ring Thickness .....	9-27
Crankcase Splitting .....	9-10	Piston Ring End Gap .....	9-27
Crankcase Assembly .....	9-10	Transmission .....	9-28
Crankshaft and Connecting Rods.....	9-14	Shift Pedal Removal .....	9-28
Crankshaft Removal .....	9-14	Shift Pedal Installation .....	9-28
Crankshaft Installation .....	9-14	External Shift Mechanism	
Connecting Rod Removal.....	9-15	Removal.....	9-29
Connecting Rod Installation .....	9-15	External Shift Mechanism	
Crankshaft/Connecting Rod		Installation.....	9-29
Cleaning.....	9-18	External Shift Mechanism	
Connecting Rod Bend.....	9-19	Inspection.....	9-29
Connecting Rod Twist.....	9-19	Transmission Shaft Removal .....	9-30
Connecting Rod Big End Side		Transmission Shaft Installation ....	9-30
Clearance.....	9-19	Transmission Shaft Disassembly .	9-31
Connecting Rod Big End Bearing		Transmission Shaft Assembly.....	9-31
Insert/Crankpin Wear .....	9-20	Shift Drum and Fork Removal.....	9-34
Crankshaft Side Clearance .....	9-21	Shift Drum and Fork Installation...	9-34
Crankshaft Runout.....	9-21	Shift Drum Disassembly.....	9-34
Crankshaft Main Bearing		Shift Drum Assembly .....	9-34
Insert/Journal Wear.....	9-22	Shift Fork Bending .....	9-35
Pistons.....	9-24	Shift Fork/Gear Groove Wear .....	9-35
Piston Removal.....	9-24	Shift Fork Guide Pin/Drum	
Piston Installation.....	9-25	Groove Wear.....	9-35
Cylinder Wear (Upper		Gear Dog and Gear Dog Hole	
Crankcase).....	9-26	Damage.....	9-35
Piston Wear .....	9-26		

# 9-2 CRANKSHAFT/TRANSMISSION

## Exploded View

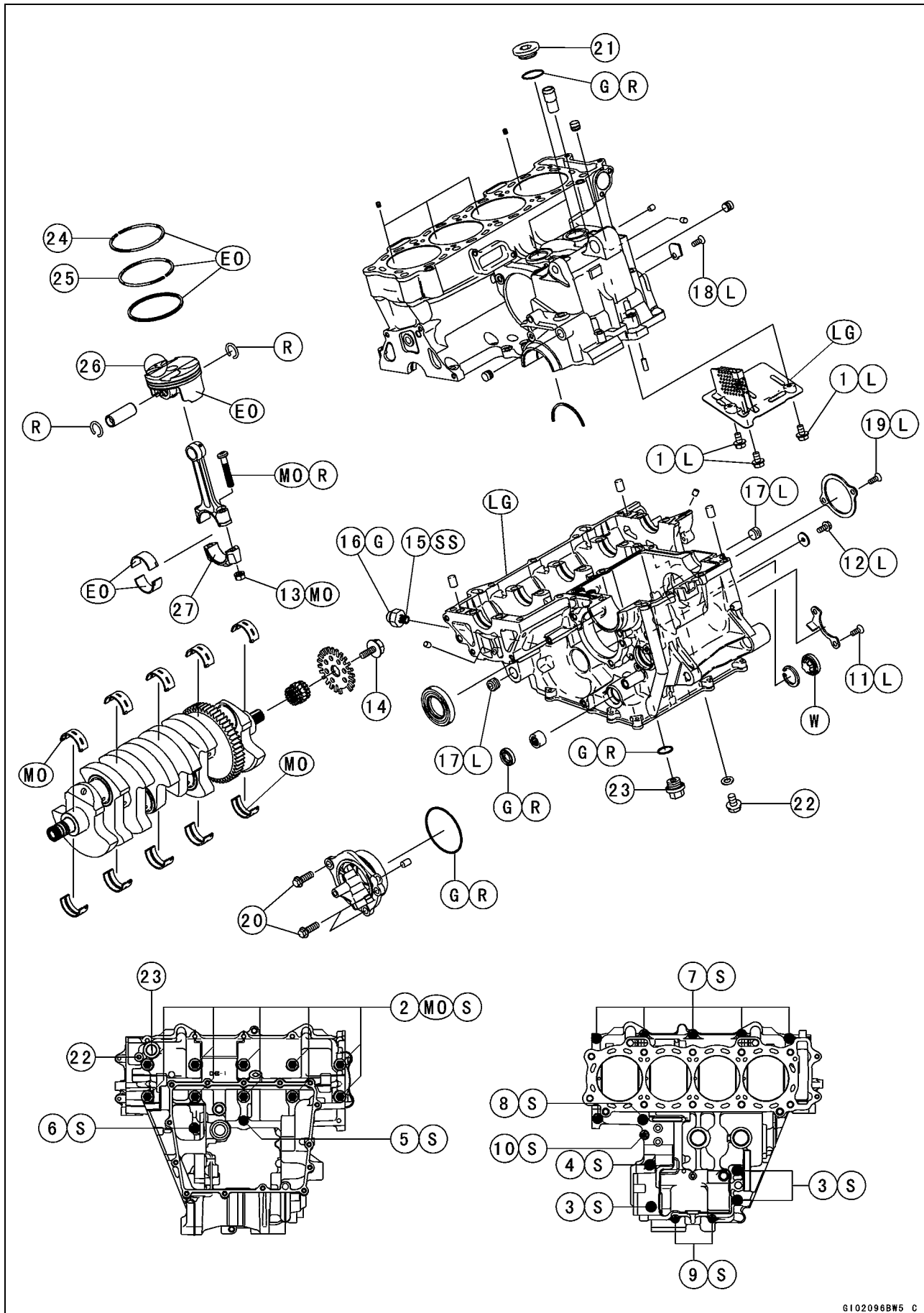

## CRANKSHAFT/TRANSMISSION 9-3

### Exploded View

No.	Fastener	Torque			Remarks
		N·m	kgf·m	ft·lb	
1	Breather Plate Bolts	9.8	1.0	87 in·lb	L
2	Crankcase Bolts (M9)	46	4.7	34	MO, S
3	Crankcase Bolts (M8, L = 90 mm)	27	2.8	20	S
4	Crankcase Bolt (M8, L = 45 mm)	27	2.8	20	S
5	Crankcase Bolt (M7, L = 85 mm)	25	2.5	18	S
6	Crankcase Bolt (M7, L = 50 mm)	25	2.5	18	S
7	Crankcase Bolts (M7, L = 45 mm)	25	2.5	18	S
8	Crankcase Bolts (M7, L = 32 mm)	25	2.5	18	S
9	Crankcase Bolts (M6, L = 40 mm)	12	1.2	104 in·lb	S
10	Crankcase Bolt (M6, L = 22 mm)	12	1.2	104 in·lb	S
11	Shift Drum Bearing Holder Screws	5.0	0.51	44 in·lb	L
12	Shift Fork Holder Bolt	12	1.2	104 in·lb	L
13	Connecting Rod Big End Nuts	see the text	←	←	←
14	Timing Rotor Bolt	40	4.1	30	
15	Oil Pressure Switch	15	1.5	11	SS
16	Oil Pressure Switch Terminal Bolt	1.5	0.15	13 in·lb	
17	Oil Passage Plugs	20	2.0	14	L
18	Plate Screw	5.0	0.51	44 in·lb	L
19	Bearing Position Plate Screws	5.0	0.51	44 in·lb	L
20	Drive Shaft Cover Bolts	25	2.5	18	
21	Plugs	17	1.7	13	
22	Coolant Drain Plug (Lower Crankcase)	9.8	1.0	87 in·lb	
23	Plug	15	1.5	11	

24. "R" marked side faces up.

25. "RN" marked side faces up.

26. Hollow mark faces forward.

27. Do not apply any grease or oil.

EO: Apply engine oil.

G: Apply grease.

L: Apply a non-permanent locking agent.

LG: Apply liquid gasket (Kawasaki Bond: 92104-1066).

M: Apply molybdenum disulfide grease.

MO: Apply molybdenum disulfide oil.

(mixture of engine oil and molybdenum disulfide grease in a weight ratio is 10 : 1)

R: Replacement Parts

S: Tightening the fasteners following the specified sequence.

SS: Apply silicone sealant (Kawasaki Bond: 56019-120).

W: Apply water.





## CRANKSHAFT/TRANSMISSION 9-5

### Exploded View

No.	Fastener	Torque			Remarks
		N·m	kgf·m	ft·lb	
1	Shift Pedal Mounting Bolt	25	2.5	18	
2	Gear Positioning Lever Bolt	12	1.2	104 in·lb	
3	Shift Shaft Return Spring Pin	29	3.0	22	L
4	Shift Drum Cam Holder Bolt	12	1.2	104 in·lb	L
5	Shift Lever Bolt	7.0	0.71	62 in·lb	
6	Tie-rod Locknuts	7.0	0.71	62 in·lb	
7	Gear Position Switch Screws	5.0	0.51	44 in·lb	L

8. Install the bearing into the drive shaft cover so that the shield side faces in.

EO: Apply engine oil.

G: Apply grease.

L: Apply a non-permanent locking agent.

R: Replacement Parts

## 9-6 CRANKSHAFT/TRANSMISSION

### Specifications

Item	Standard	Service Limit
<b>Crankcase, Crankshaft, Connecting Rods</b>		
Connecting Rod Bend	— — —	TIR 0.2/100 mm (0.008/3.94 in.)
Connecting Rod Twist	— — —	TIR 0.2/100 mm (0.008/3.94 in.)
Connecting Rod Big End Side Clearance	0.13 ~ 0.38 mm (0.0051 ~ 0.0150 in.)	0.58 mm (0.023 in.)
Connecting Rod Big End Bearing Insert/crankpin Clearance	0.030 ~ 0.060 mm (0.0012 ~ 0.0024 in.)	0.10 mm (0.0039 in.)
Crankpin Diameter:	34.484 ~ 34.500 mm (1.3576 ~ 1.3583 in.)	34.47 mm (1.3571 in.)
Marking	None	— — —
	○	— — —
Connecting Rod Big End Inside Diameter:	37.500 ~ 37.516 mm (1.4764 ~ 1.4770 in.)	— — —
Marking	None	— — —
	○	— — —
Connecting Rod Big End Bearing Insert Thickness:		
Brown	1.478 ~ 1.483 mm (0.05819 ~ 0.05839 in.)	— — —
Black	1.483 ~ 1.488 mm (0.05839 ~ 0.05858 in.)	— — —
Blue	1.488 ~ 1.493 mm (0.05858 ~ 0.05878 in.)	— — —
Connecting Rod Bolt Stretch:	(Usable Range)	
New Connecting Rod	0.24 ~ 0.34 mm (0.0094 ~ 0.0134 in.)	— — —
Used Connecting Rod	0.24 ~ 0.34 mm (0.0094 ~ 0.0134 in.)	— — —
Crankshaft Side Clearance	0.05 ~ 0.20 mm (0.0020 ~ 0.0079 in.)	0.40 mm (0.0157 in.)
Crankshaft Runout	TIR 0.02 mm (0.0008 in.) or less	TIR 0.05 mm (0.0020 in.)
Crankshaft Main Bearing Insert/journal Clearance	0.010 ~ 0.034 mm (0.0004 ~ 0.0013 in.)	0.06 mm (0.0024 in.)
Crankshaft Main Journal Diameter:	34.984 ~ 35.000 mm (1.3773 ~ 1.3780 in.)	34.96 mm (1.3764 in.)
Marking	None	— — —
	1	— — —
Crankcase Main Bearing Inside Diameter:	38.000 ~ 38.016 mm (1.4961 ~ 1.4967 in.)	— — —

## CRANKSHAFT/TRANSMISSION 9-7

### Specifications

Item	Standard	Service Limit
Marking ○	38.000 ~ 38.008 mm (1.4961 ~ 1.4963 in.)	- - -
None	38.009 ~ 38.016 mm (1.4964 ~ 1.4967 in.)	- - -
Crankshaft Main Bearing Insert Thickness:		
Brown	1.491 ~ 1.495 mm (0.0587 ~ 0.0589 in.)	- - -
Black	1.495 ~ 1.499 mm (0.0589 ~ 0.0590 in.)	- - -
Blue	1.499 ~ 1.503 mm (0.0590 ~ 0.0592 in.)	- - -
<b>Pistons</b>		
Cylinder (Upper Crankcase) Inside Diameter	75.990 ~ 76.006 mm (2.9917 ~ 2.9924 in.)	76.10 mm (2.9961 in.)
Piston Diameter	75.959 ~ 75.974 mm (2.9905 ~ 2.9911 in.)	75.81 mm (2.9846 in.)
Piston/cylinder Clearance	0.020 ~ 0.047 mm (0.0008 ~ 0.0019 in.)	- - -
Piston Ring/groove Clearance:		
Top	0.03 ~ 0.07 mm (0.0012 ~ 0.0028 in.)	0.17 mm (0.0067 in.)
Second	0.03 ~ 0.07 mm (0.0012 ~ 0.0028 in.)	0.17 mm (0.0067 in.)
Piston Ring Groove Width:		
Top	0.82 ~ 0.84 mm (0.0323 ~ 0.0331 in.)	0.92 mm (0.036 in.)
Second	0.82 ~ 0.84 mm (0.0323 ~ 0.0331 in.)	0.92 mm (0.036 in.)
Piston Ring Thickness:		
Top	0.77 ~ 0.79 mm (0.0303 ~ 0.0311 in.)	0.70 mm (0.028 in.)
Second	0.77 ~ 0.79 mm (0.0303 ~ 0.0311 in.)	0.70 mm (0.028 in.)
Piston Ring End Gap:		
Top	0.15 ~ 0.30 mm (0.0059 ~ 0.0118 in.)	0.6 mm (0.024 in.)
Second	0.30 ~ 0.45 mm (0.0118 ~ 0.0177 in.)	0.8 mm (0.031 in.)
<b>Transmission</b>		
Shift Fork Ear Thickness	5.9 ~ 6.0 mm (0.232 ~ 0.236 in.)	5.8 mm (0.228 in.)
Gear Groove Width	6.05 ~ 6.15 mm (0.238 ~ 0.242 in.)	6.25 mm (0.246 in.)
Shift Fork Guide Pin Diameter	7.9 ~ 8.0 mm (0.311 ~ 0.315 in.)	7.8 mm (0.307 in.)
Shift Drum Groove Width	8.05 ~ 8.20 mm (0.317 ~ 0.323 in.)	8.3 mm (0.327 in.)

## 9-8 CRANKSHAFT/TRANSMISSION

### Specifications

#### Selection of Crankcase, Crankshaft, Clutch Housing Gear, Gear Assembly (Alternator)

Selection Pattern	Crankcase Marking and Number	Crankshaft Marking and Number	Clutch Housing Gear Marking and Number	Gear Assembly (Alternator) Marking and Number
*1	2 14001-0040	A 13031-0033	None 13095-0033	None 16085-0043
*2	2 14001-0040	None 13031-0034	B 13095-0032	B 16085-0042
*3	2 14001-0040	B 13031-0035	A 13095-0031	A 16085-0041
*4	1 14001-0042	A 13031-0033	D 13095-0035	D 16085-0045
*5	1 14001-0042	None 13031-0034	C 13095-0034	C 16085-0044
*6	1 14001-0042	B 13031-0035	None 16095-0033	None 16085-0043
*7	None 14001-0041	A 13031-0033	C 13095-0034	C 16085-0044
*8	None 14001-0041	None 13031-0034	None 13095-0033	None 16085-0043
*9	None 14001-0041	B 13031-0035	B 13095-0032	B 16085-0042

\*: Number of Selection Pattern

#### Connecting Rod Big End Bearing Insert Selection

Con-rod Big End Bore Diameter Marking	Crankpin Diameter Marking	Bearing Insert	
		Size Color	Part Number
None	○	Brown	92139-0028
None	None	Black	92139-0027
○	○		
○	None	Blue	92139-0026

#### Crankshaft Main Bearing Insert Selection

Crankcase Main Bearing Inside Diameter Marking	Crankshaft Main Journal Diameter Marking	Bearing Insert		
		Size Color	Part Number	Journal Nos.
○	1	Brown	92139-0031	1, 5
			92139-0034	2, 3, 4
None	1	Black	92139-0030	1, 5
○	None		92139-0033	2, 3, 4
None	None	Blue	92139-0029	1, 5
			92139-0032	2, 3, 4

Special Tools and Sealants

Bearing Puller:  
57001-135

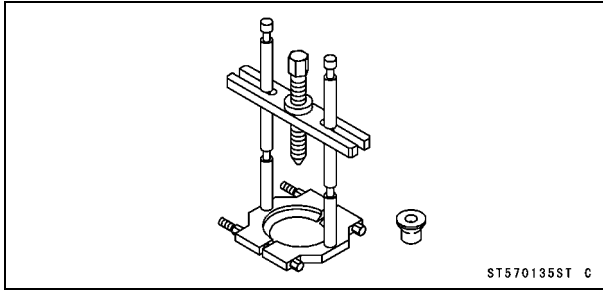

Piston Ring Compressor Belt,  $\phi 67 \sim \phi 79$ :  
57001-1097

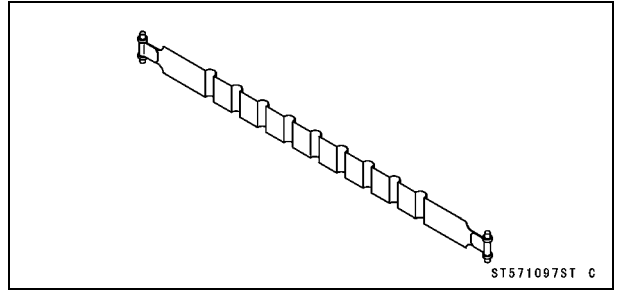

Bearing Puller Adapter:  
57001-317

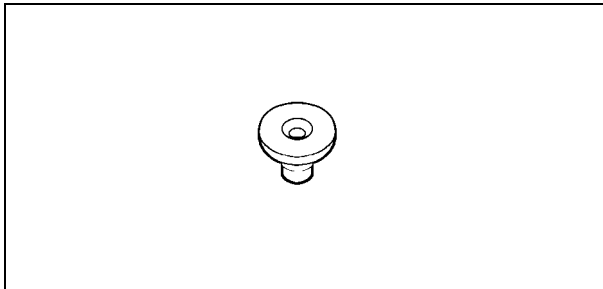

Kawasaki Bond (Silicone Sealant):  
56019-120

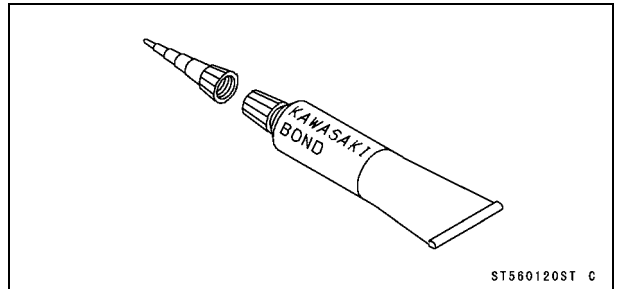

Piston Pin Puller Assembly:  
57001-910

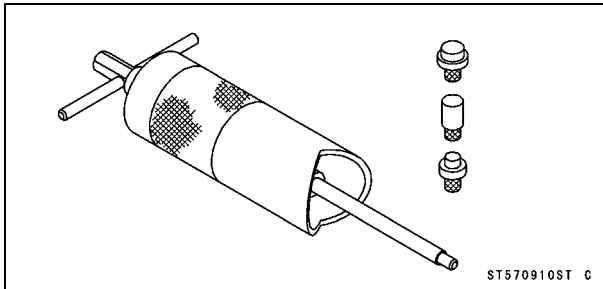

Kawasaki Bond (Silicone Sealant):  
92104-1066

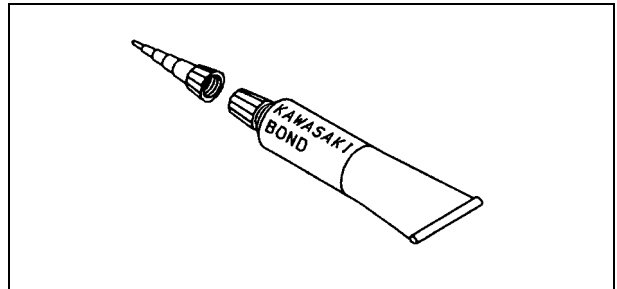

Piston Ring Compressor Grip:  
57001-1095

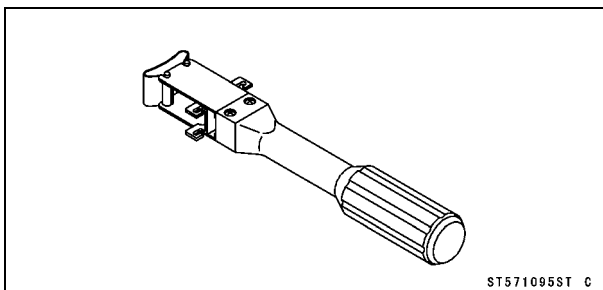

## 9-10 CRANKSHAFT/TRANSMISSION

### Crankcase Splitting

#### Crankcase Splitting

- Remove the engine (see Engine Removal/Installation chapter).
- Set the engine on a clean surface and hold the engine steady while parts are being removed.
- Remove:
  - Crankshaft Sensor (see Electrical System chapter)
  - Clutch (see Clutch chapter)
  - Starter Motor (see Electrical System chapter)
  - Oil Pump (see Engine Lubrication System chapter)
  - Alternator Rotor (see Electrical System chapter)
  - Oil Cooler (see Engine Lubrication System chapter)
  - Oil Pan (see Engine Lubrication System chapter)
  - Oil Filter (see Engine Lubrication System chapter)
  - External Shift Mechanism (see External Shift Mechanism Removal)
- ★ If the crankshaft is to be removed, remove the pistons (see Piston Removal).
- Remove the upper crankcase bolts.
  - First loosen the M6 bolts.
  - M6 Bolts [A]
  - M7 Bolts [B]
  - M8 Bolts [C]

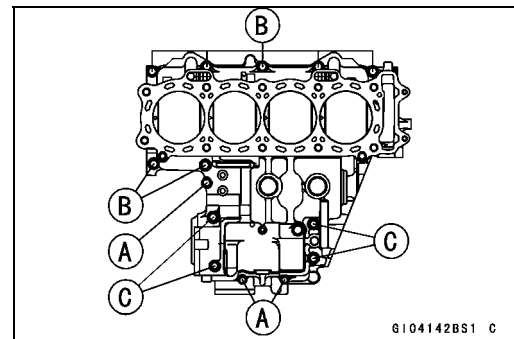

- Remove the lower crankcase bolts.
  - First loosen the M7 bolts.
  - M7 Bolts [A]
  - M9 Bolts [B]
- Tap lightly around the crankcase mating surface with a plastic mallet, and split the crankcase. Take care not to damage the crankcase.

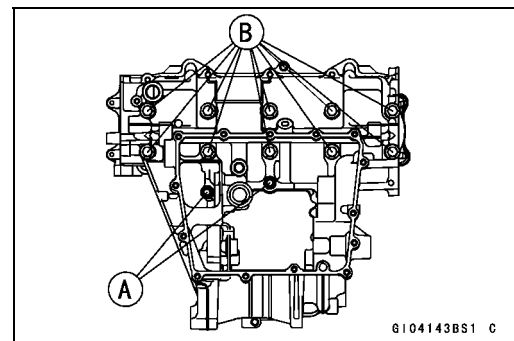

#### Crankcase Assembly

##### CAUTION

**The upper and lower crankcase halves are machined at the factory in the assembled state, so the crankcase halves must be replaced as a set.**

- With a high-flash point solvent, clean off the mating surfaces of the crankcase halves and wipe dry.
- Using compressed air, blow out the oil passages in the crankcase halves.

**Crankcase Splitting**

- If the crankcase is replaced with a new one, select the proper crankcase in accordance with the combination of the crankcase, crankshaft and clutch housing gear markings.  
 Upper Crankcase [A]  
 Crankshaft (Clutch Side) [B]  
 Clutch Housing Gear [C]
- Be sure to confirm the marking on the crankcase.

**Crankcase Selection when Replacing Crankcase**

Crankshaft Marking [D]	Clutch Housing Gear Marking [E]	Crankcase	
		Marking (Number of Hole) [F]	Part Number
A	None	2	14001-0040
B	A	2	14001-0040
None	B	2	14001-0040
A	D	1	14001-0042
B	None	1	14001-0042
None	C	1	14001-0042
A	C	None	14001-0041
B	B	None	14001-0041
None	None	None	14001-0041

**NOTE**

- If the selection mark is missing or not selection, refer to the selection section in the specifications.
- If the crankcase is replaced with a new one, refer to the Connecting Rod Big End Bearing/Crankshaft Main Bearing Insert Selection in the Selection Section.

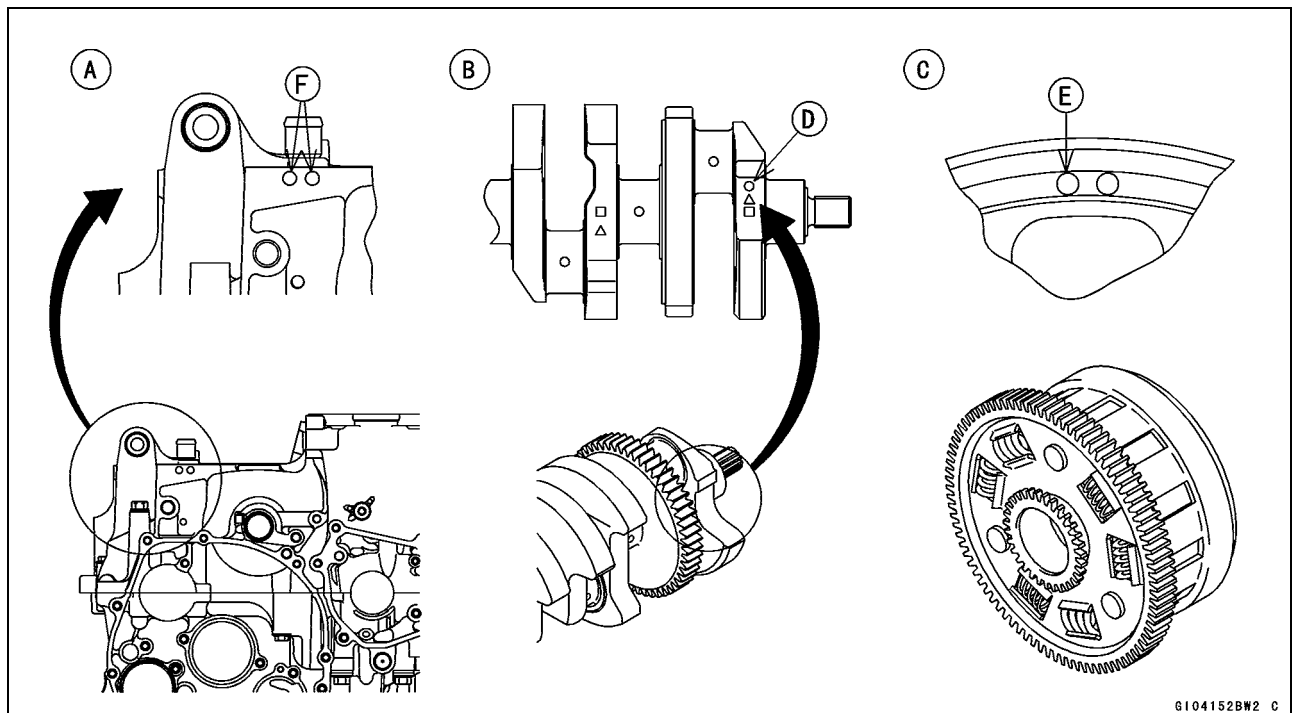

## 9-12 CRANKSHAFT/TRANSMISSION

### Crankcase Splitting

- Apply liquid gasket to the breather plate mating surface [A] 1 to 1.5 mm (0.04 to 0.06 in.) thick, and then install the breather plate.

**Sealant - Three Bond: TB1207B**

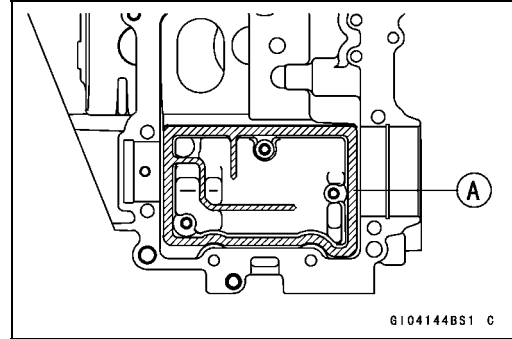

- Apply a non-permanent locking agent to the threads and tighten the bolts [A].

**Torque - Breather Plate Bolts: 9.8 N·m (1.0 kgf·m, 87 in·lb)**



- Install:
  - Crankshaft, Pistons and Connecting Rods
  - Transmission Shafts and Gears
  - Dowel Pins [A]
  - Shift Drum
  - Shift Forks and Shift Rods
- Before fitting the lower case on the upper case, check the following.
  - Check to see that the shift drum and transmission gears are in the neutral position.



- Apply liquid gasket to the mating surface of the lower crankcase half.

**Sealant - Kawasaki Bond (Silicone Sealant) [A]: 92104-1066**

**Three Bond [B]: TB1207B**

**3.5 ~ 10 mm (0.14 ~ 0.39 in.) [C]**

#### NOTE

○Especially, apply a sealant carefully so that it shall be filled up on the grooves.

#### CAUTION

**Do not apply liquid gasket around the crankshaft main bearing inserts, and oil passage holes.**

- Fit the lower crankcase to the upper crankcase.

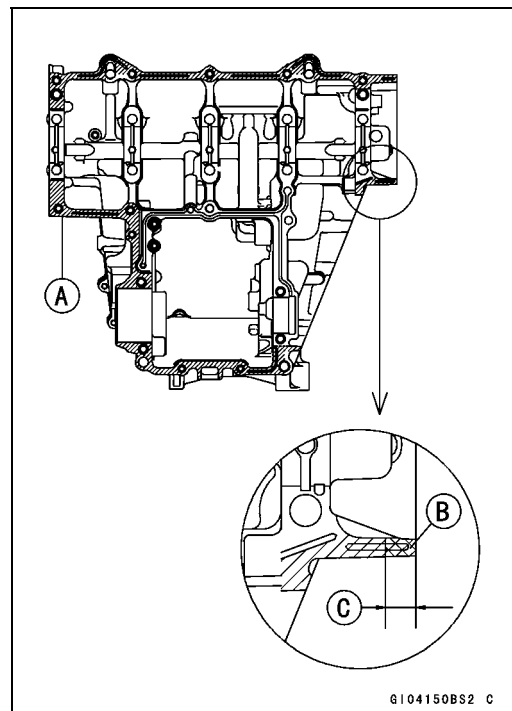



**Crankcase Splitting**

- The M9 bolts has a washer, replace it with a new one.
- Apply molybdenum disulfide oil to the seating surface [A] on the lower crankcase for the M9 bolts [B].  
Washer [C]

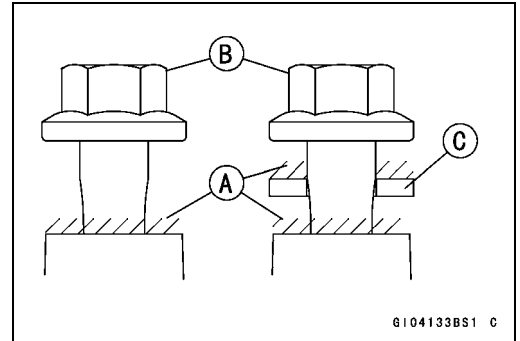

- Tighten the lower crankcase bolts using the following steps.
- Following the sequence numbers on the lower crankcase half, tighten the M9 bolts [1 ~ 10] with washers.

**Torque - Crankcase Bolts (M9): 46 N·m (4.7 kgf·m, 34 ft·lb)**

- Tighten the M7 bolts.

**Torque - Crankcase Bolts (M7): 25 N·m (2.5 kgf·m, 18 ft·lb)**

- L = 85 mm (3.35 in.) [A]
- L = 50 mm (1.97 in.) [B]

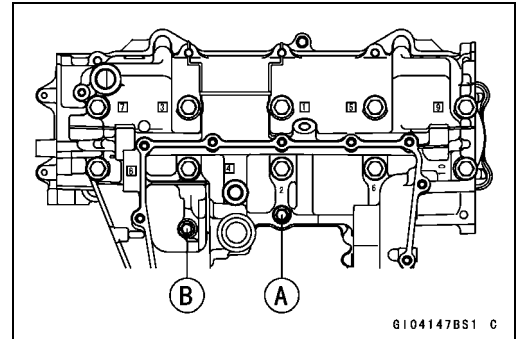

- Tighten the upper crankcase bolts in the order listed.
- The M8 bolts has a washer, replace it with a new one.
- Tighten the M8 bolts with washers.

**Torque - Crankcase Bolts (M8): 27 N·m (2.8 kgf·m, 20 ft·lb)**

- L = 90 mm (3.54 in.) [A]
- L = 45 mm (1.77 in.) [B]

**Crankcase Bolts (M7): 25 N·m (2.5 kgf·m, 18 ft·lb)**

- L = 45 mm (1.77 in.) [C]
- L = 32 mm (1.26 in.) [D]

**Crankcase Bolts (M6, L = 40 mm) [E]: 12 N·m (1.2 kgf·m, 104 in·lb)**

**Crankcase Bolt (M6, L = 22 mm) [F]: 12 N·m (1.2 kgf·m, 104 in·lb)**

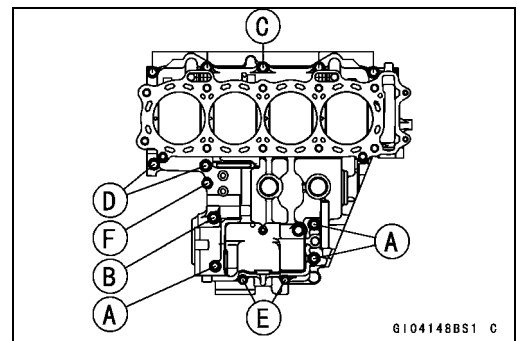

- After tightening all crankcase bolts, check the following items.
- Crankshaft and transmission shafts turn freely.
- While spinning the output shaft, gears shift smoothly from the 1st to neutral, and neutral to 1st.

## 9-14 CRANKSHAFT/TRANSMISSION

### Crankshaft and Connecting Rods

#### *Crankshaft Removal*

- Split the crankcase (see Crankcase Splitting).
- Remove the crankshaft (see Connecting Rod Removal).

#### *Crankshaft Installation*

- If the crankshaft is replaced with a new one, select the proper crankshaft in accordance with the combination of the crankshaft, crankcase and clutch housing gear markings.

Upper Crankcase [A]

Crankshaft (Clutch Side) [B]

Clutch Housing Gear [C]

- Be sure to confirm the marking on the crankshaft.

#### **Crankshaft Selection when Replacing Crankshaft**

Crankcase Marking (Number of Hole) [F]	Clutch Housing Gear Marking [E]	Crankshaft	
		Marking [D]	Part Number
2	A	B	13031-0035
2	B	None	13031-0034
2	None	A	13031-0033
1	C	None	13031-0034
1	D	A	13031-0033
1	None	B	13031-0035
None	B	B	13031-0035
None	C	A	13031-0033
None	None	None	13031-0034

#### **NOTE**

- If the selection mark is missing or not selection, refer to the selection section in the specifications.
- If the crankshaft is replaced with a new one, refer to the Connecting Rod Big End Bearing/Crankshaft Main Bearing Insert Selection in the Selection Section.

#### **CAUTION**

**If the crankshaft, bearing inserts, or crankcase halves are replaced with new ones, select the bearing inserts and check clearance with a plastigage (press gauge) before assembling engine to be sure the correct bearing inserts are installed.**

- Apply molybdenum disulfide oil solution to the crankshaft main bearing inserts.

**Crankshaft and Connecting Rods**

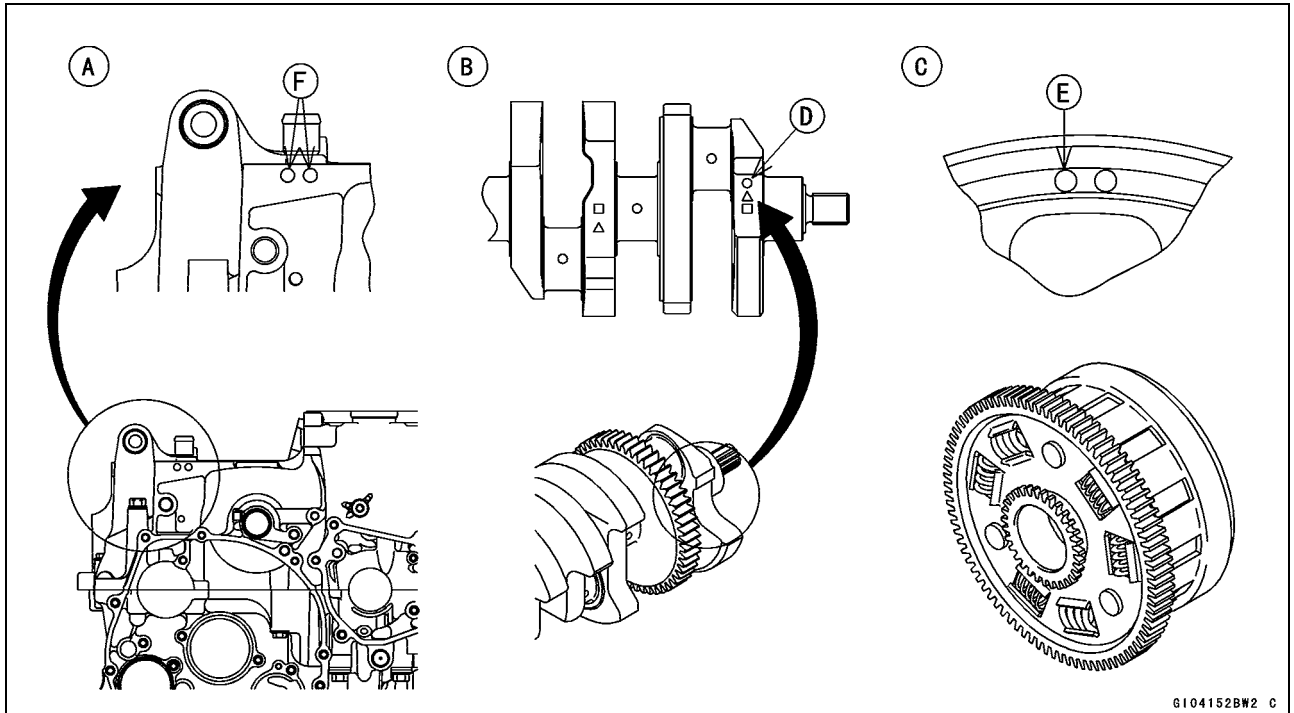

6104152BW2 C

**Connecting Rod Removal**

- Split the crankcase (see Crankcase Splitting).
- Remove the connecting rod nuts [A].
- Remove the crankshaft.

**NOTE**

○ Mark and record the locations of the connecting rods and their big end caps so that they can be reassembled in their original positions.

- Remove the piston (see piston Removal).

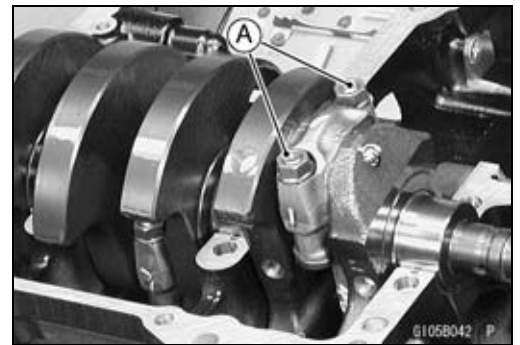

61058042 P

**CAUTION**

Discard the connecting rod bolts. To prevent damage to the crankpin surfaces, do not allow the connecting rod bolts to bump against the crankpins.

**Connecting Rod Installation**

**CAUTION**

To minimize vibration, the connecting rods should have the same weight mark.

- Big End Cap [A]
- Connecting Rod [B]
- Weight Mark, Alphabet [C]
- Diameter Mark [D]: "○" or no mark

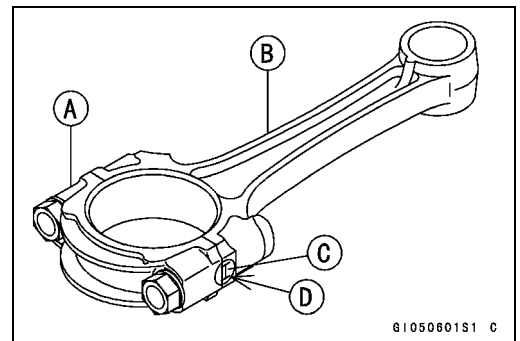

61050801S1 C

**CAUTION**

If the connecting rods, big end bearing inserts, or crankshaft are replaced with new ones, select the bearing insert and check clearance with a plasti-gage (press gauge) before assembling engine to be sure the correct bearing inserts are installed.

## 9-16 CRANKSHAFT/TRANSMISSION

### Crankshaft and Connecting Rods

- Apply molybdenum disulfide oil to the inner surface of the upper and lower bearing inserts [A].
- Apply molybdenum disulfide oil to the threads [B] and seating surface [C] of the connecting rod nuts.
- Install the inserts so that their nails [D] are on the same side and fit them into the recess of the connecting rod and cap.

#### CAUTION

**Wrong application of oil and grease could cause bearing damage.**

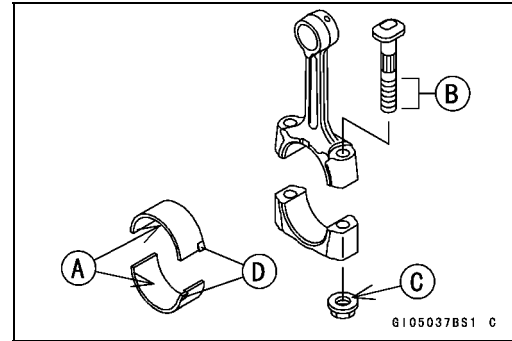

- When installing the inserts [A], be careful not to damage the insert surface with the edge of the connecting rod [B] or the cap [C]. One way to install inserts is as follows.

Installation [D] to Cap

Installation [E] to Connecting Rod

Push [F]

Spare Dowel Pin [G]

Connecting Rod Bolts [H]

- Remove debris and clean the surface of inserts.
- Install the cap on the connecting rod, aligning the weight and diameter marks.

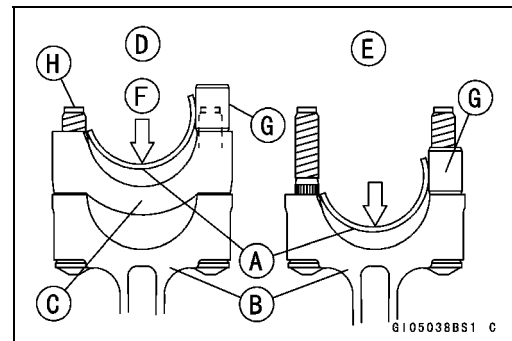

- Install the crankshaft (see Crankshaft Installation).
- Install each connecting rod on its original crankpin.
- The connecting rod big end is bolted using the “plastic region fastening method”.
- This method precisely achieves the needed clamping force without exceeding it unnecessarily, allowing the use of thinner, lighter bolts further decreasing connecting rod weight.
- There are two types of the plastic region fastening. One is a bolt length measurement method and other is a rotation angle method. Observe one of the following two, but the bolt length measurement method is preferable because this is a more reliable way to tighten the big end nuts.

#### CAUTION

**The connecting rod bolts are designed to stretch when tightened. Never reuse the connecting rod bolts. See the table below for correct bolt and nut usage.**

#### CAUTION

**Be careful not to overtighten the nuts. The bolts must be positioned on the seating surface correctly to prevent the bolt heads from hitting the crankcase.**

**Crankshaft and Connecting Rods**

(1) Bolt Length Measurement Method

- Be sure to clean the bolts, nuts, and connecting rods thoroughly with a high-flash point solvent, because the new connecting rods, bolts, and nuts are treated with an anti-rust solution.

**⚠ WARNING**

**Clean the bolts, nuts, and connecting rods in a well-ventilated area, and take care that there is no spark or flame anywhere near the working area. This includes any appliance with a pilot light. Because of the danger of highly flammable liquids, do not use gasoline or low-flash point solvents to clean them.**

**CAUTION**

**Immediately dry the bolts and nuts with compressed air after cleaning. Clean and dry the bolts and nuts completely.**

- Install new bolts in reused connecting rods.
- Dent both bolt head and bolt tip with a punch as shown.
- Before tightening, use a point micrometer to measure the length of new connecting rod bolts and record the values to find the bolt stretch.
  - Connecting Rod [A]
  - Dent here with a punch [B].
  - Nuts [C]
  - Fit micrometer pins into dents [D].
- Apply a small amount of molybdenum disulfide oil to the following.
  - Threads of Nuts and Bolts
  - Seating Surfaces of Nuts and Connecting rods
- Tighten the big end nuts until the bolt elongation reaches the length specified in the table.
- Check the length of the connecting rod bolts.
- ★ If the stretch is more than the usable range, the bolt has stretched too much. An overelongated bolt may break in use.

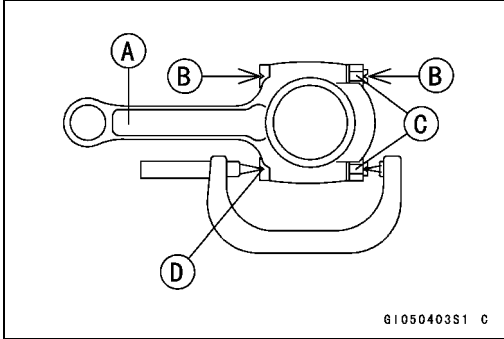

$$\text{Bolt Length after tightening} - \text{Bolt Length before tightening} = \text{Bolt Stretch}$$

Connect- ing Rod Assy	Bolt	Nut	Usable Range of Connecting Rod Bolt Stretch
New	Use the bolts attached to new con-rod.	Attached to new con-rod	0.24 ~ 0.34 mm (0.0094 ~ 0.0134 in.)
		New	
Used	Replace the bolts with new ones.	Used	0.24 ~ 0.34 mm (0.0094 ~ 0.0134 in.)
		New	

## 9-18 CRANKSHAFT/TRANSMISSION

### Crankshaft and Connecting Rods

#### (2) Rotation Angle Method

- ★ If you don't have a point micrometer, you may tighten the nuts using the "Rotation Angle Method".
- Be sure to clean the bolts, nuts and connecting rods thoroughly with a high-flash point solvent, because the new connecting rods, bolts and nuts are treated with an anti-rust solution.

#### **⚠ WARNING**

**Clean the bolts, nuts and connecting rods in a well-ventilated area, and take care that there is no spark or flame anywhere near the working area. This includes any appliance with a pilot light. Because of the danger of highly flammable liquids, do not use gasoline or low-flash point solvents to clean them.**

#### **CAUTION**

**Immediately dry the bolts and nuts with compressed air after cleaning.  
Clean and dry the bolts and nuts completely.**

- Install new bolts in reused connecting rods.
- Apply a small amount of molybdenum disulfide oil to the following.
  - Threads [A] of Nuts and Bolts
  - Seating Surfaces [B] of Nuts and Connecting Rods

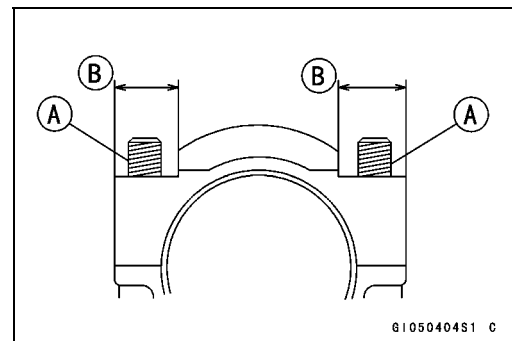

- First, tighten the nuts to the specified torque. See the table below.
- Next, tighten the nuts **150°**.
- Mark [A] the connecting rod big end caps and nuts so that nuts can be turned 150° [B] properly.

Connecting Rod Assy	Bolt	Nut	Torque + Angle N·m (kgf·m, ft·lb)
New	Use the bolts attached to new con-rod.	Attached to new con-rod	20 (2.0, 15) + 150°
		New	20 (2.0, 15) + 150°
Used	Replace the bolts with new ones	Used	20 (2.0, 15) + 150°
		New	20 (2.0, 15) + 150°

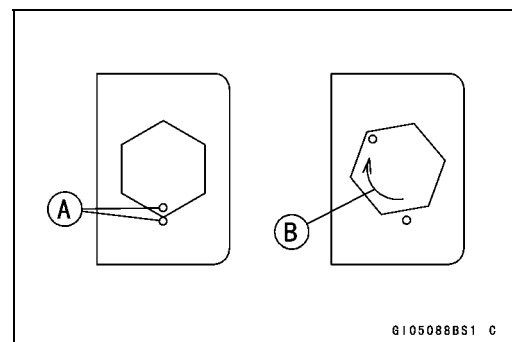

#### *Crankshaft/Connecting Rod Cleaning*

- After removing the connecting rods from the crankshaft, clean them with a high-flash point solvent.
- Blow the crankshaft oil passages with compressed air to remove any foreign particles or residue that may have accumulated in the passages.

**Crankshaft and Connecting Rods**

**Connecting Rod Bend**

- Remove the connecting rod big end bearing inserts, and reinstall the connecting rod big end cap.
  - Select an arbor [A] of the same diameter as the connecting rod big end, and insert the arbor through the connecting rod big end.
  - Select an arbor of the same diameter as the piston pin and at least 100 mm (3.94 in.) long, and insert the arbor [B] through the connecting rod small end.
  - On a surface plate, set the big-end arbor on V block [C].
  - With the connecting rod held vertically, use a height gauge to measure the difference in the height of the arbor above the surface plate over a 100 mm (3.94 in.) length to determine the amount of connecting rod bend.
- ★ If connecting rod bend exceeds the service limit, the connecting rod must be replaced.

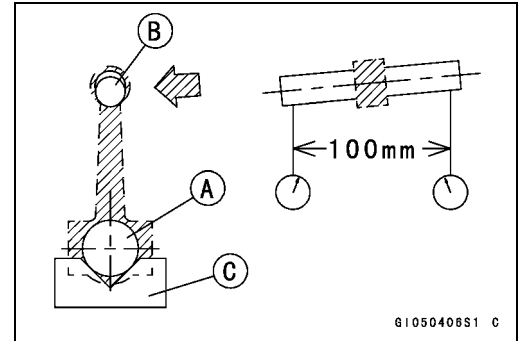

**Connecting Rod Bend**

**Service Limit: TIR 0.2/100 mm (0.008/3.94 in.)**

**Connecting Rod Twist**

- With the big-end arbor [A] still on V block [C], hold the connecting rod horizontally and measure the amount that the arbor [B] varies from being paralleled with the surface plate over a 100 mm (3.94 in.) length of the arbor to determine the amount of connecting rod twist.
- ★ If connecting rod twist exceeds the service limit, the connecting rod must be replaced.

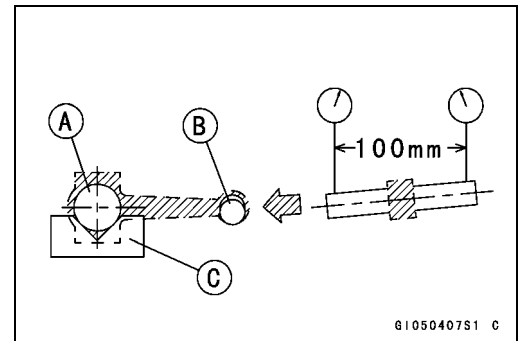

**Connecting Rod Twist**

**Service Limit: TIR 0.2/100 mm (0.008/3.94 in.)**

**Connecting Rod Big End Side Clearance**

- Measure connecting rod big end side clearance.
- Insert a thickness gauge [A] between the big end and either crank web to determine clearance.

**Connecting Rod Big End Side Clearance**

**Standard: 0.13 ~ 0.38 mm (0.0051 ~ 0.0150 in.)**

**Service Limit: 0.58 mm (0.023 in.)**

- ★ If the clearance exceeds the service limit, replace the connecting rod with new one and then check clearance again. If clearance is too large after connecting rod replacement, the crankshaft also must be replaced.

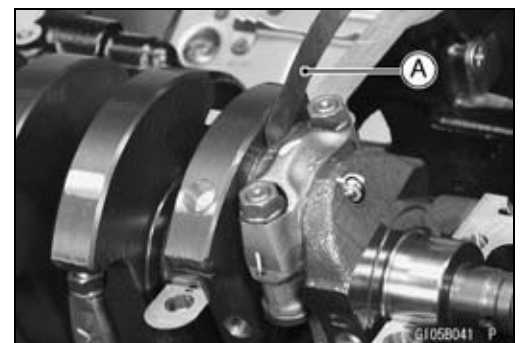

## 9-20 CRANKSHAFT/TRANSMISSION

### Crankshaft and Connecting Rods

#### Connecting Rod Big End Bearing Insert/Crankpin Wear

- Measure the bearing insert/crankpin [B] clearance with plastigage [A].
- Tighten the big end nuts to the specified torque (see Connecting Rod Installation).

#### NOTE

○ Do not move the connecting rod and crankshaft during clearance measurement.

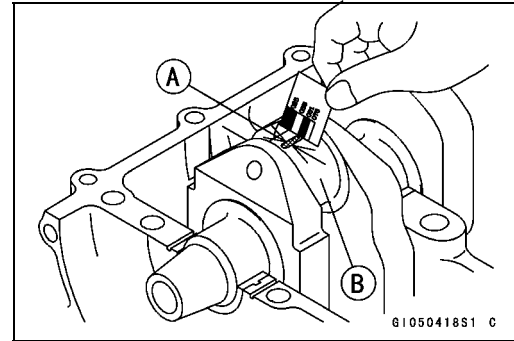

#### CAUTION

After measurement, replace the connecting rod bolts.

#### Connecting Rod Big End Bearing Insert/Crankpin Clearance

**Standard:** 0.030 ~ 0.060 mm (0.0012 ~ 0.0024 in.)

**Service Limit:** 0.10 mm (0.0039 in.)

- ★ If the clearance is within the standard, no bearing replacement is required.
- ★ If the clearance is between 0.061 mm (0.0024 in.) and the service limit (0.10 mm, 0.0039 in.), replace the bearing inserts [A] with inserts painted blue [B]. Check insert/crankpin clearance with the plastigage. The clearance may exceed the standard slightly, but it must not be less than the minimum in order to avoid bearing seizure.
- ★ If the clearance exceeds the service limit, measure the diameter of the crankpins.

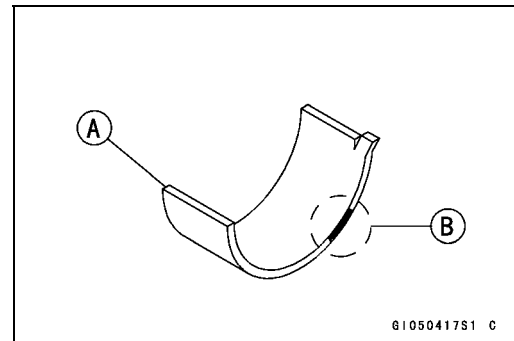

#### Crankpin Diameter

**Standard:** 34.484 ~ 34.500 mm (1.3576 ~ 1.3583 in.)

**Service Limit:** 34.47 mm (1.3571 in.)

- ★ If any crankpin has worn past the service limit, replace the crankshaft with a new one.
- ★ If the measured crankpin diameters are not less than the service limit, but do not coincide with the original diameter markings on the crankshaft, make new marks on it.

#### Crankpin Diameter Marks

**None** 34.484 ~ 34.492 mm (1.3576 ~ 1.3579 in.)

○ 34.493 ~ 34.500 mm (1.3580 ~ 1.3583 in.)

△: Crankpin Diameter Marks, "○" or no mark.

- Measure the connecting rod big end inside diameter, and mark each connecting rod big end in accordance with the inside diameter.
- Tighten the connecting rod big end nuts to the specified torque (see Connecting Rod Installation).

#### NOTE

○ The mark already on the big end should almost coincide with the measurement.

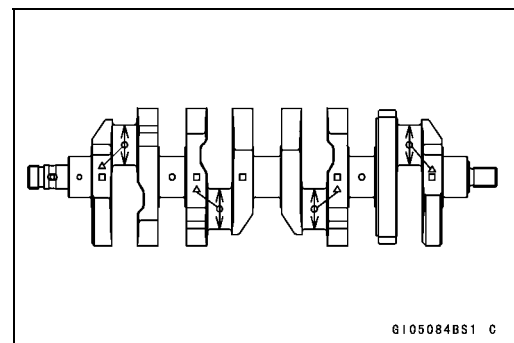



**Crankshaft and Connecting Rods**

**Connecting Rod Big End Inside Diameter Marks**

- None 37.500 ~ 37.508 mm (1.4764 ~ 1.4766 in.)
- 37.509 ~ 37.516 mm (1.4767 ~ 1.4770 in.)

Big End Cap [A]  
 Connecting Rod [B]  
 Weight Mark, Alphabet [C]  
 Diameter Mark (Around Weight Mark) [D]: "○" or no mark

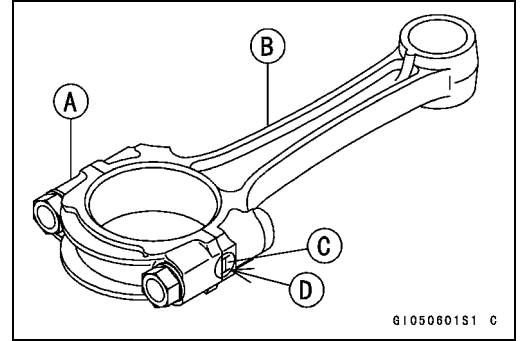

- Select the proper bearing insert [A] in accordance with the combination of the connecting rod and crankshaft coding. Size Color [B]

Con-rod Big End Inside Diameter Marking	Crankpin Diameter Marking	Bearing Insert	
		Size Color	Part Number
None	○	Brown	92139-0028
None	None	Black	92139-0027
○	○		
○	None	Blue	92139-0026

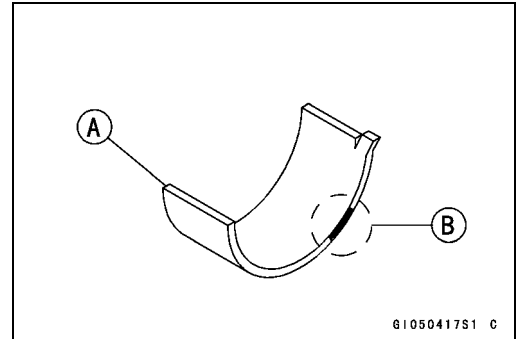

- Install the new inserts in the connecting rod and check insert/crankpin clearance with the plastigage.

**Crankshaft Side Clearance**

- Insert a thickness gauge [A] between the crankcase main bearing and the crank web at the No.2 journal [B] to determine clearance.
- ★ If the clearance exceeds the service limit, replace the crankcase halves as a set.

**NOTE**

○ The upper and lower crankcase halves are machined at the factory in the assembled state, so the crankcase halves must be replaced as a set.

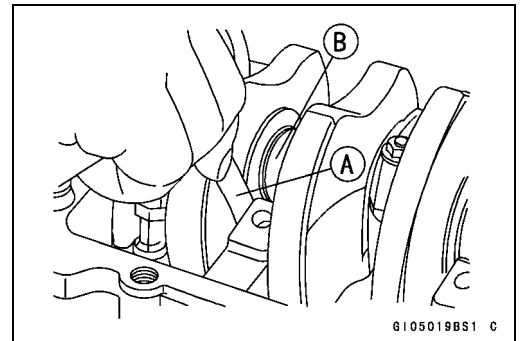

**Crankshaft Side Clearance**

- Standard: 0.05 ~ 0.20 mm (0.0020 ~ 0.0079 in.)
- Service Limit: 0.40 mm (0.0157 in.)

**Crankshaft Runout**

- Measure the crankshaft runout.
- ★ If the measurement exceeds the service limit, replace the crankshaft.

**Crankshaft Runout**

- Standard: TIR 0.02 mm (0.0008 in.) or less
- Service Limit: TIR 0.05 mm (0.0020 in.)

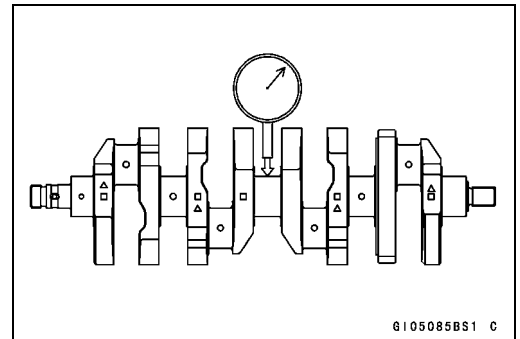

## 9-22 CRANKSHAFT/TRANSMISSION

### Crankshaft and Connecting Rods

#### Crankshaft Main Bearing Insert/Journal Wear

- Using a plastigage (press gauge) [A], measure the bearing insert/journal [B] clearance.

#### NOTE

- Tighten the crankcase bolts to the specified torque (see Crankcase Assembly).
- Do not turn the crankshaft during clearance measurement.
- Journal clearance less than 0.025 mm (0.00098 in.) can not be measured by plastigage, however, using genuine parts maintains the minimum standard clearance.

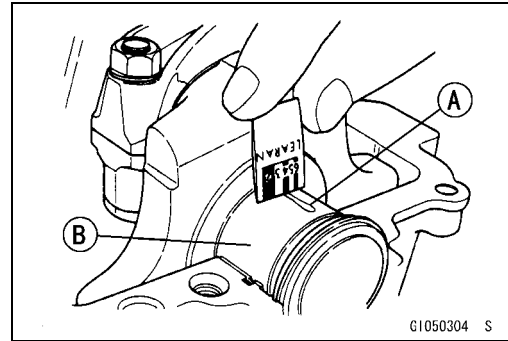

#### Crankshaft Main Bearing Insert/Journal Clearance

**Standard:** 0.010 ~ 0.034 mm (0.0004 ~ 0.0013 in.)

**Service Limit:** 0.06 mm (0.0024 in.)

- ★ If the clearance is within the standard, no bearing replacement is required.
- ★ If the clearance is between 0.035 mm (0.0014 in.) and the service limit (0.06 mm, 0.0024 in.), replace the bearing inserts [A] with inserts painted blue [B]. Check insert/journal clearance with the plastigage. The clearance may exceed the standard slightly, but it must not be less than the minimum in order to avoid bearing seizure.
- ★ If the clearance exceeds the service limit, measure the diameter of the crankshaft main journal.

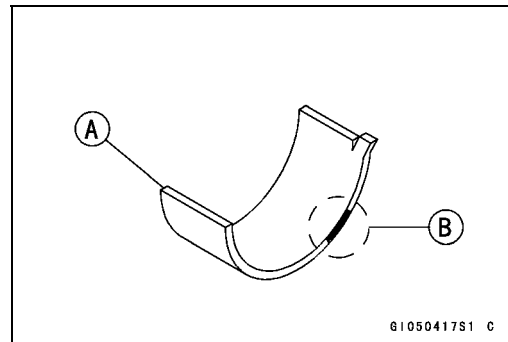

#### Crankshaft Main Journal Diameter

**Standard:** 34.984 ~ 35.000 mm (1.3773 ~ 1.3780 in.)

**Service Limit:** 34.96 mm (1.3764 in.)

- ★ If any journal has worn past the service limit, replace the crankshaft with a new one.
- ★ If the measured journal diameters are not less than the service limit, but do not coincide with the original diameter markings on the crankshaft, make new marks on it.

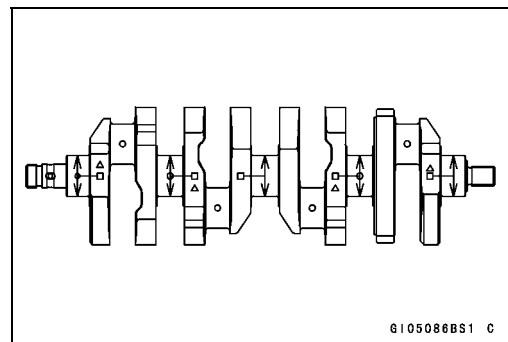

#### Crankshaft Main Journal Diameter Marks

**None** 34.984 ~ 34.992 mm (1.3773 ~ 1.3776 in.)

**1** 34.993 ~ 35.000 mm (1.3777 ~ 1.3780 in.)

□: Crankshaft Main Journal Diameter Marks, "1" or no mark.

- Measure the main bearing inside diameter, and mark the upper crankcase half in accordance with the inside diameter.  
A: Crankcase Main Bearing Inside Diameter Marks, "○" mark or no mark.

- Tighten the crankcase bolts to the specified torque (see Crankcase Assembly).

#### NOTE

- The mark already on the upper crankcase half should almost coincide with the measurement.

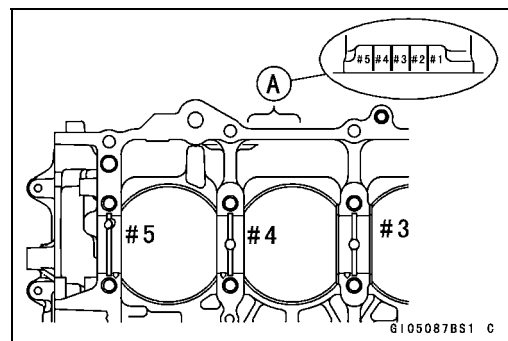

**Crankshaft and Connecting Rods**

**Crankcase Main Bearing Inside Diameter Marks**

○ 38.000 ~ 38.008 mm (1.4961 ~ 1.4963 in.)

None 38.009 ~ 38.016 mm (1.4964 ~ 1.4967 in.)

- Select the proper bearing insert [A] in accordance with the combination of the crankcase and crankshaft coding.  
Size Color [B]

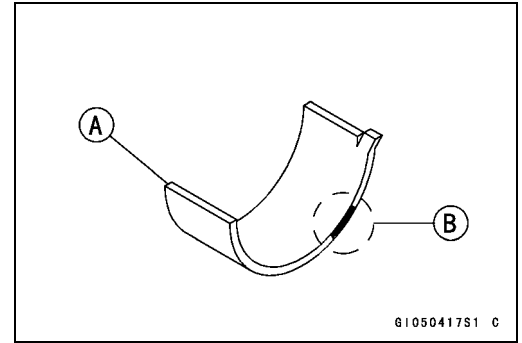

Crankcase Main Bearing Inside Diameter Marking	Crankshaft Main Journal Diameter Marking	Bearing Insert		
		Size Color	Part Number	Journal Nos.
○	1	Brown	92139-0031	1, 5
			92139-0034	2, 3, 4
None	1	Black	92139-0030	1, 5
○	None		92139-0033	2, 3, 4
None	None	Blue	92139-0029	1, 5
			92139-0032	2, 3, 4

- Install the new inserts in the crankcase halves and check insert/journal clearance with the plastigage.

## 9-24 CRANKSHAFT/TRANSMISSION

### Pistons

#### *Piston Removal*

- Split the crankcase (see Crankcase Splitting).
- Remove the connecting rod nuts [A].
- Remove the connecting rod big end caps.

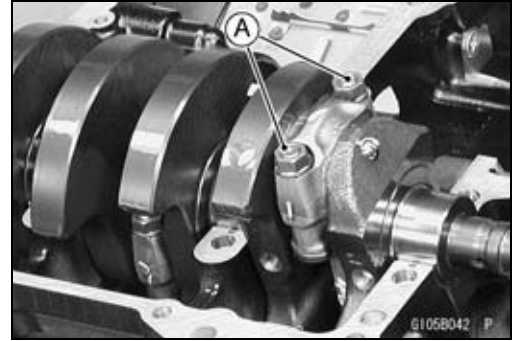

- Remove the crankshaft.
- Remove the piston to the cylinder head side.

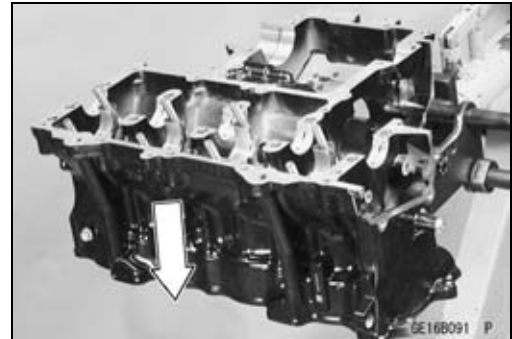

- Remove the piston pin snap ring [A].

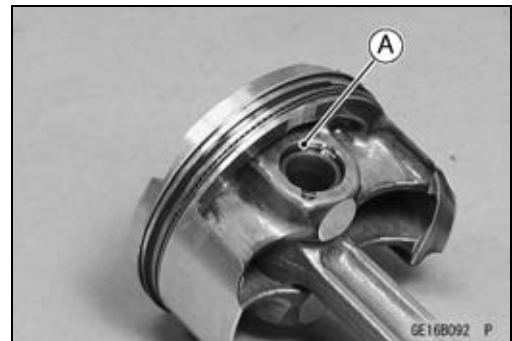

- Remove the piston pins.  
**Special Tool - Piston Pin Puller Assembly: 57001-910 [A]**
- Remove the pistons.

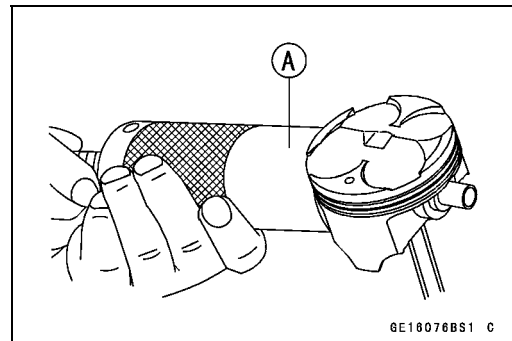

- Carefully spread the ring opening with your thumbs and then push up on the opposite side of the ring [A] to remove it.
- Remove the 3-piece oil ring with your thumbs in the same manner.

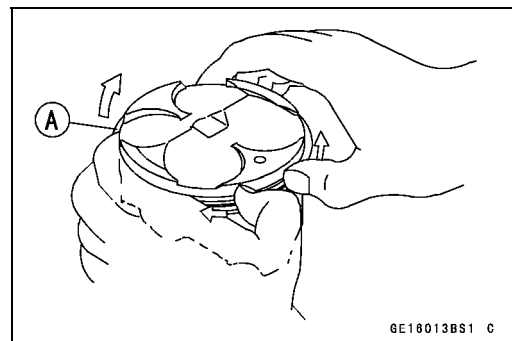

**Pistons**

*Piston Installation*

- Apply molybdenum disulfide oil solution to the oil ring expander, and install the oil ring expander [A] in the bottom piston ring groove so the ends [B] butt together.
- Apply molybdenum disulfide oil solution to the oil ring steel rails, and install the oil ring steel rails, one above the expander and one below it.
- Spread the rail with your thumbs, but only enough to fit the rail over the piston.
- Release the rail into the bottom piston ring groove.

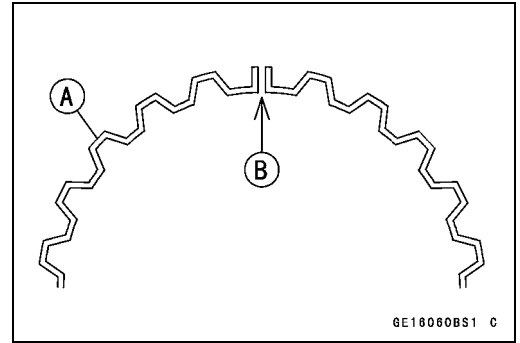

**NOTE**

○The oil ring rails have no "top" or "bottom".

- Do not mix up the top and second ring.
- Install the top ring [A] so that the "R" mark [B] faces up.
- Install the second ring [C] so that the "RN" mark [D] faces up.
- Apply molybdenum disulfide oil solution to the piston rings.

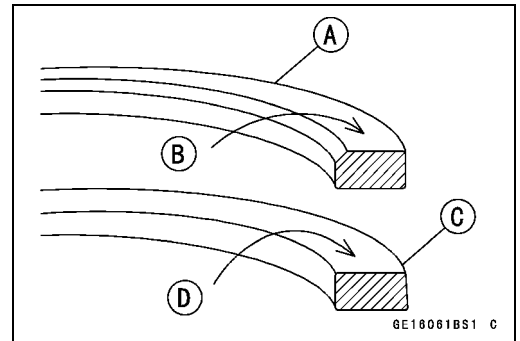

**NOTE**

○If a new piston is used, use new piston ring.

- Fit a new piston pin snap ring into the side of the piston so that the ring opening [A] does not coincide with the slit [B] of the piston pin hole.
- Apply molybdenum disulfide oil solution to the piston pins and piston journals.
- When installing the piston pin snap ring, compress it only enough to install it and no more.

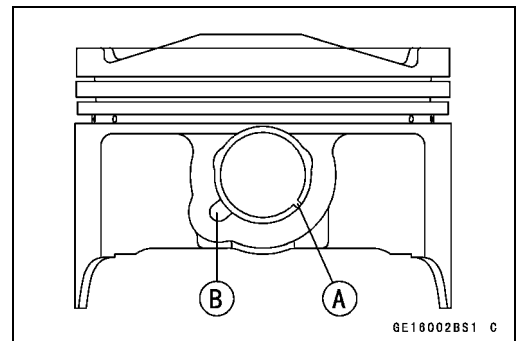

**CAUTION**

**Do not reuse snap rings, as removal weakens and deforms them. They could fall out and score the cylinder wall.**

- The piston ring openings must be positioned as shown in the figure. The openings of the oil ring steel rails must be about 30-40° of angle from the opening of the top ring.

- Top Ring [A]
- Second Ring [B]
- Oil Ring Steel Rails [C]
- Oil Ring Expander [D]
- Hollow [E]
- 30 ~ 40° [F]

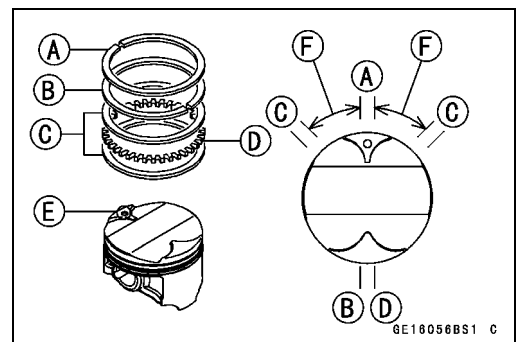

## 9-26 CRANKSHAFT/TRANSMISSION

### Pistons

- Install the piston with its marking hollow facing exhaust side.
- Using the piston ring compressor assy [A] to install the piston from the cylinder head side.

**Special Tools - Piston Ring Compressor Grip: 57001-1095**  
**Piston Ring Compressor Belt,  $\phi 67 \sim \phi 79$ : 57001-1097**

- Install the crankshaft.
- Install the connecting rod to the crankshaft (see Connecting Rod Installation).

#### Cylinder Wear (Upper Crankcase)

- Since there is a difference in cylinder wear (upper crankcase) in different directions, take a side-to-side and a front-to-back measurement at each of the two locations (total of four measurements) shown in the figure.

- ★ If any of the cylinder inside diameter measurements exceeds the service limit, replace the crankcase.

10 mm (0.39 in.) [A]

60 mm (2.36 in.) [B]

#### Cylinder Inside Diameter

**Standard: 75.990 ~ 76.006 mm (2.9917 ~ 2.9924 in.)**

**Service Limit: 76.10 mm (2.9961 in.)**

#### Piston Wear

- Measure the outside diameter [A] of each piston 5 mm (0.20 in.) [B] up from the bottom of the piston at a right angle to the direction of the piston pin.

- ★ If the measurement is under service limit, replace the piston.

#### Piston Diameter

**Standard: 75.959 ~ 75.974 mm (2.9905 ~ 2.9911 in.)**

**Service Limit: 75.81 mm (2.9846 in.)**

#### Piston Ring, Piston Ring Groove Wear

- Check for uneven groove wear by inspecting the ring seating.

- ★ The rings should fit perfectly parallel to groove surfaces. If not, replace the piston and all the piston rings.

- With the piston rings in their grooves, make several measurements with a thickness gauge [A] to determine piston ring/groove clearance.

#### Piston Ring/Groove Clearance

**Standard:**

**Top 0.03 ~ 0.07 mm (0.0012 ~ 0.0028 in.)**

**Second 0.03 ~ 0.07 mm (0.0012 ~ 0.0028 in.)**

**Service Limit:**

**Top 0.17 mm (0.0067 in.)**

**Second 0.17 mm (0.0067 in.)**

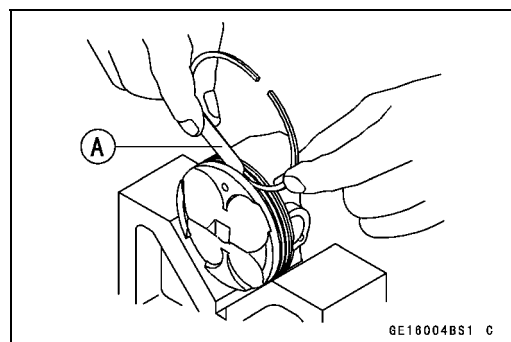
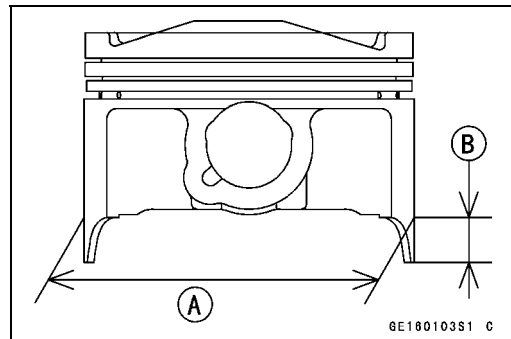
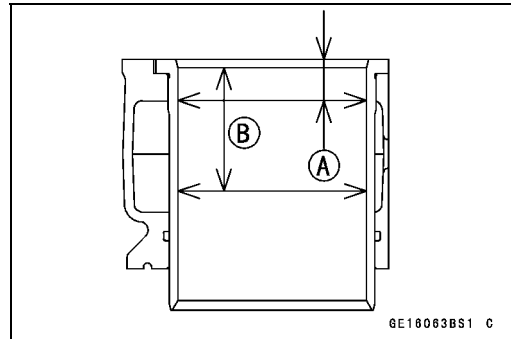
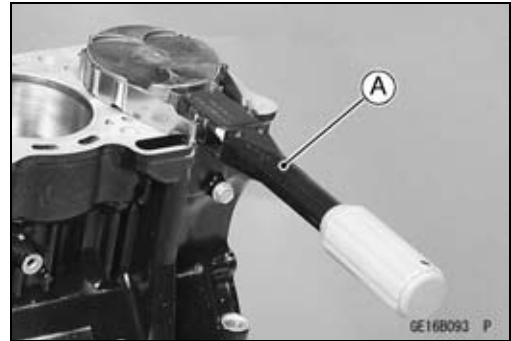

**Pistons**

*Piston Ring Groove Width*

- Measure the piston ring groove width.
- Use a vernier caliper at several points around the piston.

**Piston Ring Groove Width**

**Standard:**

- Top [A]            0.82 ~ 0.84 mm (0.0323 ~ 0.0331 in.)
- Second [B]      0.82 ~ 0.84 mm (0.0323 ~ 0.0331 in.)

**Service Limit:**

- Top [A]            0.92 mm (0.036 in.)
- Second [B]      0.92 mm (0.036 in.)

- ★ If the width of any of the two grooves is wider than the service limit at any point, replace the piston.

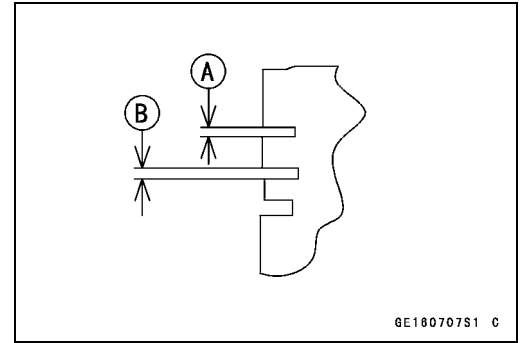

6E180707S1 C

*Piston Ring Thickness*

- Measure the piston ring thickness.
- Use the micrometer to measure at several points around the ring.

**Piston Ring Thickness**

**Standard:**

- Top [A]            0.77 ~ 0.79 mm (0.0303 ~ 0.0311 in.)
- Second [B]      0.77 ~ 0.79 mm (0.0303 ~ 0.0311 in.)

**Service Limit:**

- Top [A]            0.70 mm (0.028 in.)
- Second [B]      0.70 mm (0.028 in.)

- ★ If any of the measurements is less than the service limit on either of the rings, replace all the rings.

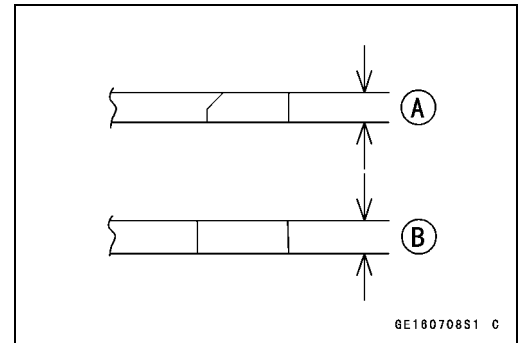

6E180708S1 C

**NOTE**

- When using new rings in a used piston, check for uneven groove wear. The rings should fit perfectly parallel to the groove sides. If not, replace the piston.

*Piston Ring End Gap*

- Place the piston ring [A] inside the cylinder (upper crankcase), using the piston to locate the ring squarely in place. Set it close to the bottom of the cylinder, where cylinder wear is low.
- Measure the gap [B] between the ends of the ring with a thickness gauge.

**Piston Ring End Gap**

**Standard:**

- Top                0.15 ~ 0.30 mm (0.0059 ~ 0.0118 in.)
- Second          0.30 ~ 0.45 mm (0.0118 ~ 0.0177 in.)

**Service Limit:**

- Top                0.6 mm (0.024 in.)
- Second          0.8 mm (0.031 in.)

- ★ If the end gap of either ring is greater than the service limit, replace all the rings.

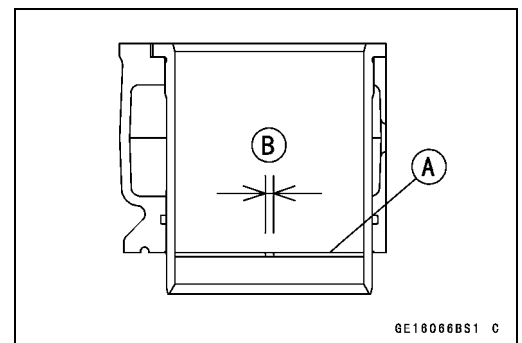

6E18066BS1 C

## 9-28 CRANKSHAFT/TRANSMISSION

### Transmission

#### Shift Pedal Removal

- Mark [A] the position of the shift lever [B] on the shift shaft so that it can be installed later in the same position.
- Remove:
  - Shift Lever Bolt [C]
  - Shift Lever

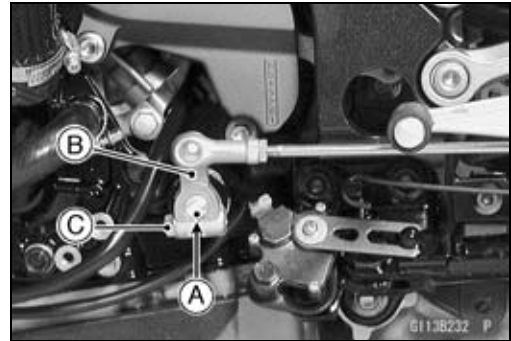

- Remove:
  - Shift Pedal Mounting Bolt [A]
  - Tie-rod [B]

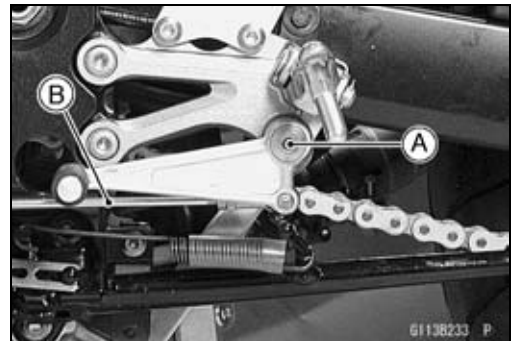

#### Shift Pedal Installation

- Tighten:
  - Torque - Shift Pedal Mounting Bolt [A]: 25 N·m (2.5 kgf·m, 18 ft·lb)**
  - Footpeg Bracket [B]
  - Shift Pedal [C]
  - Washer [D]
  - Bushing [E]

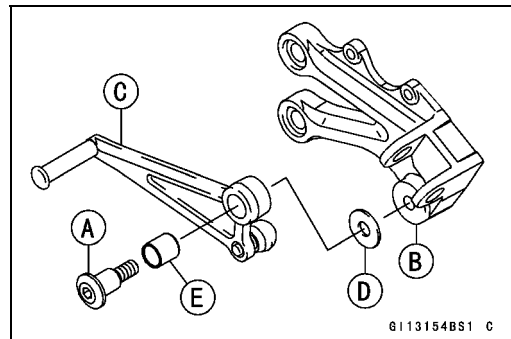

- Install the shift lever [A], aligning the mark (previously marked).
- Tighten:
  - Torque - Shift Lever Bolt: 7.0 N·m (0.71 kgf·m, 62 in·lb)**
- Install the shift pedal [B] as shown.
  - About 92° [C]
  - 9 mm (0.35 in.) [D]
- To adjust the pedal position, loosen the front locknut [E] (left-hand threads) and rear locknut [F] and then turn the tie-rod [G].
- Tighten:
  - Torque - Tie-rod Locknuts: 7.0 N·m (0.71 kgf·m, 62 in·lb)**

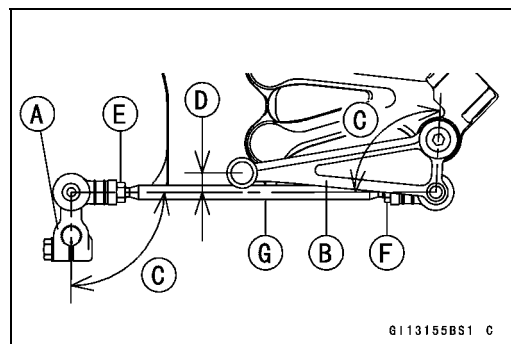



**Transmission**

*External Shift Mechanism Removal*

- Remove:
  - Engine (see Engine Removal/Installation chapter)
  - Clutch (see Clutch chapter)
  - Oil Pan (see Engine Lubrication System chapter)
- Remove the snap ring [A] and washer.
- Remove the shift shaft assembly while pulling the shift mechanism arm.



- Remove:
  - Gear Positioning Lever Bolt [A] and Spacer
  - Gear Positioning Lever [B], Washer and Spring



*External Shift Mechanism Installation*

- Install the gear positioning lever [A] as shown.
  - Spring [B]
  - Washer [C]
  - Spacer [D]
  - Bolt [E]
- Tighten:
  - Torque - Gear Positioning Lever Bolt: 12 N·m (1.2 kgf·m, 104 in·lb)**

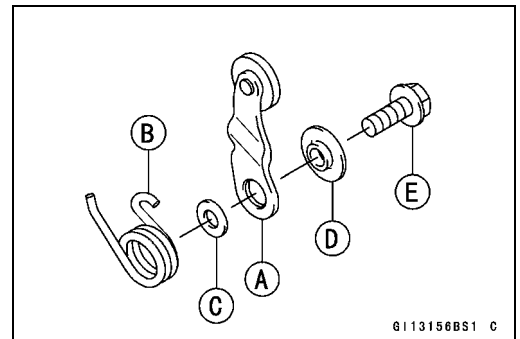

*External Shift Mechanism Inspection*

- Examine the shift shaft [A] for any damage.
  - ★ If the shaft is bent, straighten or replace it.
  - ★ If the serration [B] are damaged, replace the shaft.
  - ★ If the springs [C] are damaged in any way, replace them.
  - ★ If the shift mechanism arm [D] is damaged in any way, replace the arm.

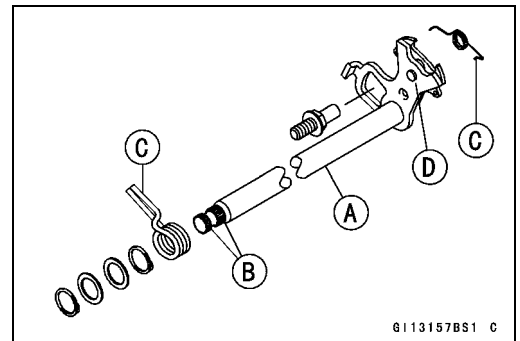

- Check the return spring pin [A] is not loose.
  - ★ If it is loose, unscrew it, apply a non-permanent locking agent to the threads, and tighten it.
    - Torque - Shift Shaft Return Spring Pin: 29 N·m (3.0 kgf·m, 22 ft·lb)**
- Check the gear positioning lever [B] and its spring for breaks or distortion.
  - ★ If the lever or spring are damaged in any way, replace them.
- Visually inspect the shift drum cam [C].
  - ★ If they are badly worn or if they show any damage, replace it.

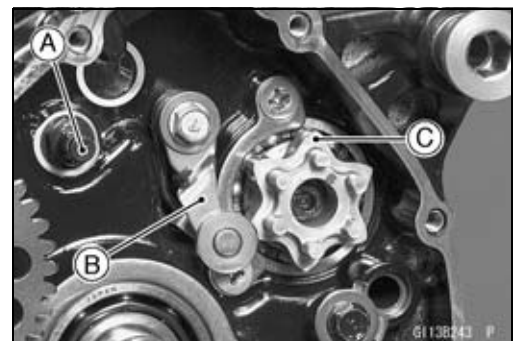

## 9-30 CRANKSHAFT/TRANSMISSION

### Transmission

#### Transmission Shaft Removal

- Split the crankcase (see Crankcase Splitting).
- Remove the output shaft [A].

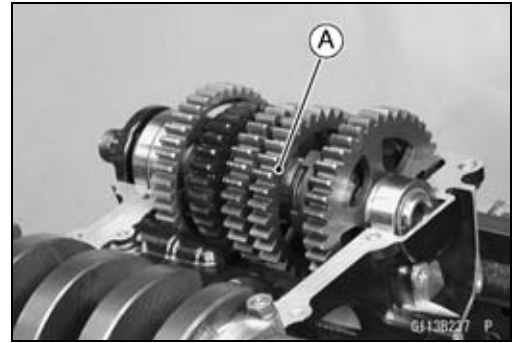

- Remove the cover bolts [A] and cover [B].
- Remove the shift forks (see Shift Drum and Fork Removal).
- Pull out the drive shaft.

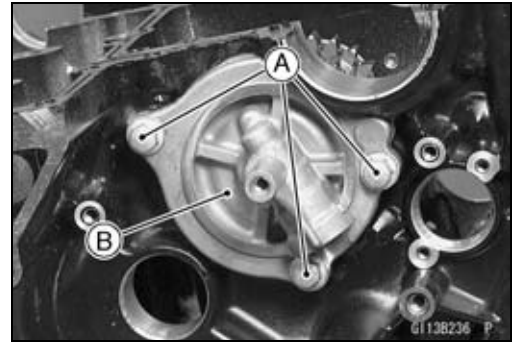

#### Transmission Shaft Installation

- Check to see that the set pin [A] and set ring [B] are in place.
  - Install the output shaft into the upper crankcase half.
  - Apply engine oil to the bearing.
- The bearing set pin and ring must match properly with the hole or groove in the bearing outer races. When they are properly matched, there is no clearance [A] between the crankcase and the bearing outer races.

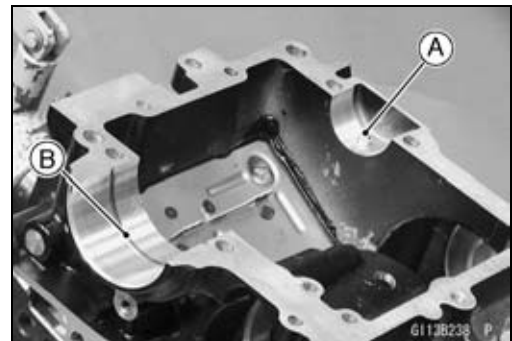

- Install the drive shaft into the lower crankcase half.
- Apply grease to the O-ring.
- Install the pin and cover.
- Tighten:

**Torque - Drive Shaft Cover Bolts [A]: 25 N·m (2.5 kgf·m, 18 ft·lb)**



- Assemble the crankcase.
- Press in the oil seal [A] onto collar [B] so that the surface of the oil seal is flush with the counterbore bottom surface [C] of the crankcase.

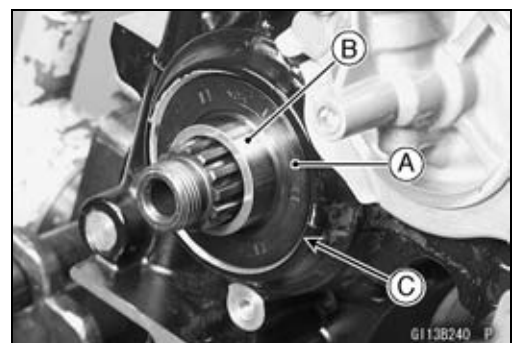

**Transmission**

*Transmission Shaft Disassembly*

- Remove the transmission shafts (see Transmission Shaft Removal).
  - Remove the circlips, disassemble the transmission shafts.
  - The 5th gear [A] on the output shaft has three steel balls assembled into it for the positive neutral finder mechanism. Remove the 5th gear.
  - Set the output shaft in a vertical position holding the 3rd gear [B].
  - Spin the 5th gear quickly [C] and pull it off upward.
  - Remove the ball bearing [A] from each shafts.
- Special Tools - Bearing Puller: 57001-135 [B]**  
**Bearing Puller Adapter: 57001-317 [C]**
- Discard the bearing.

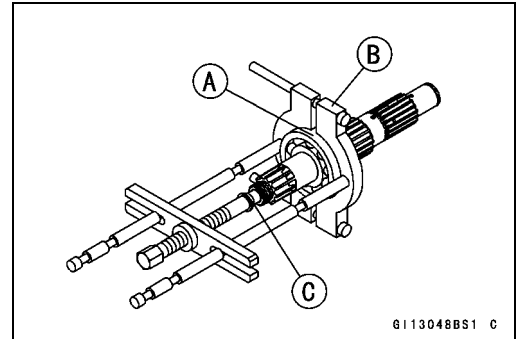
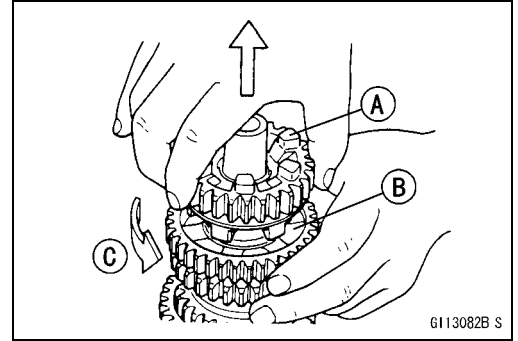

*Transmission Shaft Assembly*

- Apply engine oil to the bushings, ball bearings and shafts.
- Install the gear bushings [A] on the shaft with their holes [B] aligned.
- Replace any circlips removed with new ones.
- Install the circlips [A] so that the opening [B] of it is aligned with spline grooves [C].
- Install the circlips so that the mark [D] on them faces to each gear side.

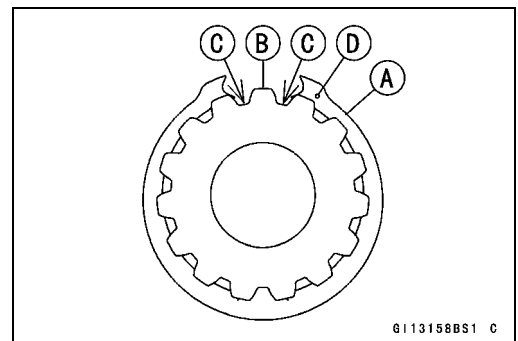
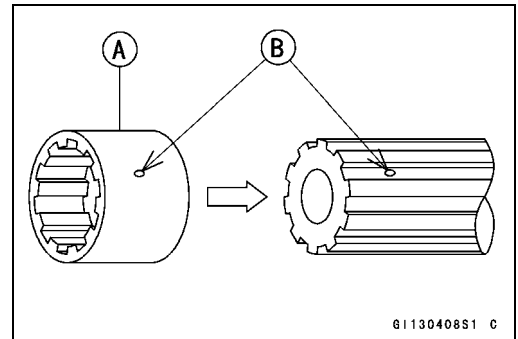

## 9-32 CRANKSHAFT/TRANSMISSION

### Transmission

- The drive shaft gears can be recognized by size: the gear with the smallest diameter is 1st gear, and the largest one is 6th gear. Be sure that all parts are put back in the correct sequence and all circlips and washers are properly in place.
- Install the 3rd/4th gear onto the drive shaft with their oil holes aligned.
- Install the 6th gear bushing onto the drive shaft with their oil holes aligned.
- The output shaft gears can be recognized by size: the gear with the largest diameter is 1st gear, and the smallest one is 6th gear. Be sure that all parts are put back in the correct sequence and all circlips and washers are properly in place.
- Install the 5th and 6th gears onto the output shaft with their oil holes aligned.
- Install the 3rd/4th gear bushings onto the output shaft with their oil holes aligned.
- Fit the steel balls into the 5th gear holes in the output shaft, aligning three oil holes [D].  
5th Gear [A]  
Output Shaft [B]  
Steel Balls [C]

#### CAUTION

**Do not apply grease to the balls to hold them in place. This will cause the positive neutral finder mechanism to malfunction.**

- After assembling the 5th gear with steel balls in place on the output shaft, check the ball-locking effect that the 5th gear doesn't come out of the output shaft when moving it up and down by hand.
- Check that each gear spins or slides freely on the transmission shafts without binding after assembly.

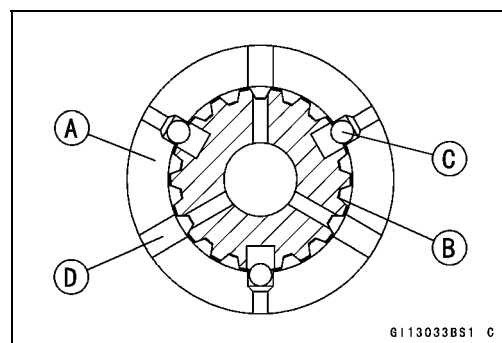

Transmission

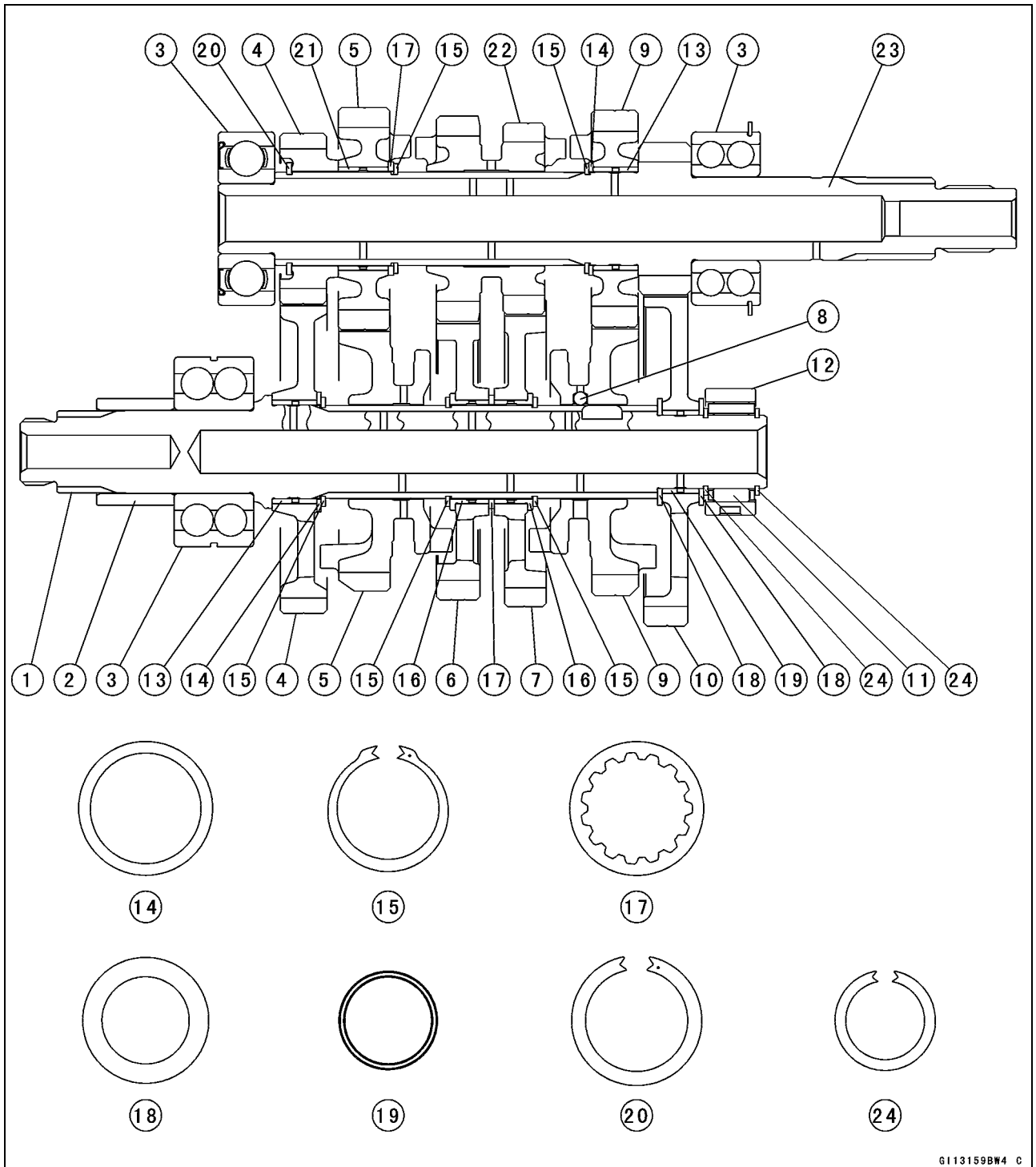

G113159BW4 C

- |                        |   |
|------------------------|---|
| 1. Collar              | 13. Bushing                                 |
| 2. Output Shaft        | 14. Thrust Washer, $\phi 34$ mm (1.34 in.)  |
| 3. Ball Bearing        | 15. Snap Ring                               |
| 4. 2nd Gear            | 16. Bushing                                 |
| 5. 6th (Top) Gear      | 17. Toothed Washer, $\phi 34$ mm (1.34 in.) |
| 6. 4th Gear            | 18. Thrust Washer, $\phi 32$ mm (1.26 in.)  |
| 7. 3rd Gear            | 19. Bushing                                 |
| 8. Steel Ball          | 20. Snap Ring                               |
| 9. 5th Gear            | 21. Bushing                                 |
| 10. 1st Gear           | 22. 3rd/4th Gear                            |
| 11. Needle Bearing     | 23. Drive Shaft                             |
| 12. Bearing Outer Race | 24. Snap Ring                               |

## 9-34 CRANKSHAFT/TRANSMISSION

### Transmission

#### Shift Drum and Fork Removal

- Remove:
  - Lower Crankcase Half (see Crankcase Splitting)
  - Transmission Shaft
  - External Shift Mechanism (see External Shift Mechanism Removal)
  - Bolt [A], Washer and Screws [B]
  - Shift Drum Bearing Holder [C]
- Pull out the shift rods [D], and take off the shift forks.
- Pull out the shift drum [E].

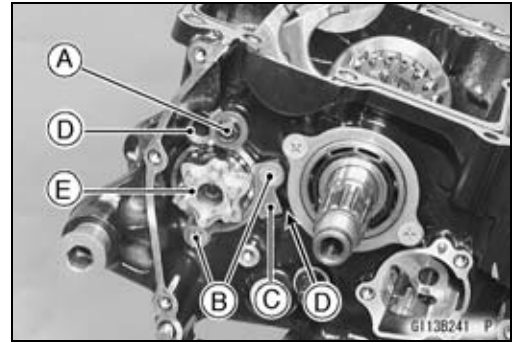

#### Shift Drum and Fork Installation

- Apply engine oil to the shift drum, forks and rods.
- Install the shift rods [A], noting the groove position.
- Position the one with shortest ears [B] on the drive shaft and place the pin in the center groove in the shift drum [C].
- The two forks [D] on the output shaft are identical.
- Install the forks as shown.
- Apply a non-permanent locking agent to the threads of the shift drum bearing holder screws and shift fork holder bolt, and tighten them.

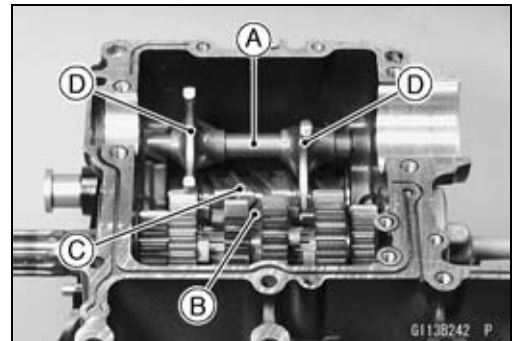

**Torque - Shift Fork Holder Bolt: 12 N·m (1.2 kgf·m, 104 in·lb)**

**Shift Drum Bearing Holder Screws: 5.0 N·m (0.51 kgf·m, 44 in·lb)**

#### Shift Drum Disassembly

- Remove the shift drum (see Shift Drum and Fork Removal).
- While holding the shift drum with a vise, remove the shift drum cam holder bolt.
  - Shift Drum Cam Holder Bolt [A]
  - Dowel Pin [B]

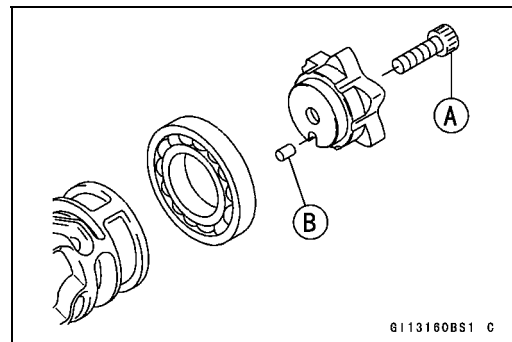

#### Shift Drum Assembly

- Be sure to install the dowel pin.
- Apply a non-permanent locking agent to the threads of the shift drum cam holder bolt, and tighten it.

**Torque - Shift Drum Cam Holder Bolt: 12 N·m (1.2 kgf·m, 104 in·lb)**

**Transmission**

*Shift Fork Bending*

- Visually inspect the shift forks, and replace any fork that is bent. A bent fork could cause difficulty in shifting, or allow the transmission to jump out of gear when under power.
- 90° [A]

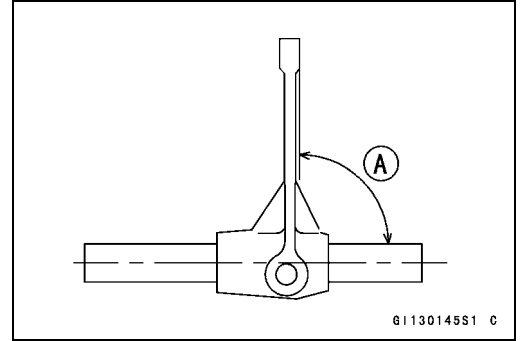

*Shift Fork/Gear Groove Wear*

- Measure the thickness of the shift fork ears [A], and measure the width [B] of the gear grooves.
- ★ If the thickness of a shift fork ear is less than the service limit, the shift fork must be replaced.

**Shift Fork Ear Thickness**

- Standard: 5.9 ~ 6.0 mm (0.232 ~ 0.236 in.)
- Service Limit: 5.8 mm (0.228 in.)

- ★ If the gear groove is worn over the service limit, the gear must be replaced.

**Gear Groove Width**

- Standard: 6.05 ~ 6.15 mm (0.238 ~ 0.242 in.)
- Service Limit: 6.25 mm (0.246 in.)

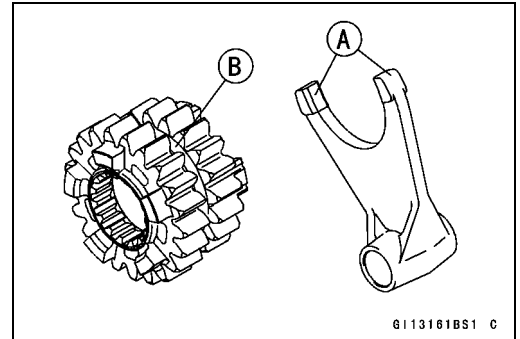

*Shift Fork Guide Pin/Drum Groove Wear*

- Measure the diameter of each shift fork guide pin [A], and measure the width [B] of each shift drum groove.
- ★ If the guide pin on any shift fork is less than the service limit, the fork must be replaced.

**Shift Fork Guide Pin Diameter**

- Standard: 7.9 ~ 8.0 mm (0.311 ~ 0.315 in.)
- Service Limit: 7.8 mm (0.307 in.)

- ★ If any shift drum groove is worn over the service limit, the drum must be replaced.

**Shift Drum Groove Width**

- Standard: 8.05 ~ 8.20 mm (0.317 ~ 0.323 in.)
- Service Limit: 8.3 mm (0.327 in.)

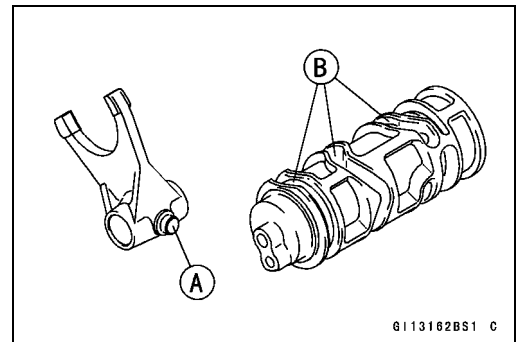

*Gear Dog and Gear Dog Hole Damage*

- Visually inspect the gear dogs [A] and gear dog holes [B].
- ★ Replace any damaged gears or gears with excessively worn dogs or dog holes.

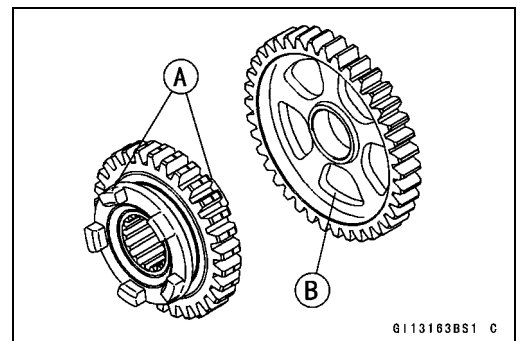





# Wheels/Tires

## Table of Contents

Exploded View .....	10-2
Specifications .....	10-4
Special Tools .....	10-5
Wheels (Rims) .....	10-6
Front Wheel Removal .....	10-6
Front Wheel Installation .....	10-6
Rear Wheel Removal .....	10-7
Rear Wheel Installation .....	10-8
Wheel Inspection .....	10-10
Axle Inspection .....	10-10
Balance Inspection .....	10-10
Balance Adjustment .....	10-11
Balance Weight Removal .....	10-11
Balance Weight Installation .....	10-11
Tires .....	10-13
Air Pressure Inspection/Adjustment .....	10-13
Tire Inspection .....	10-13
Tire Removal .....	10-13
Tire Installation .....	10-13
Tire Repair .....	10-15
Hub Bearing .....	10-16
Hub Bearing Removal .....	10-16
Hub Bearing Installation .....	10-16
Hub Bearing Inspection .....	10-16
Hub Bearing Lubrication .....	10-17

# 10-2 WHEELS/TIRES

## Exploded View

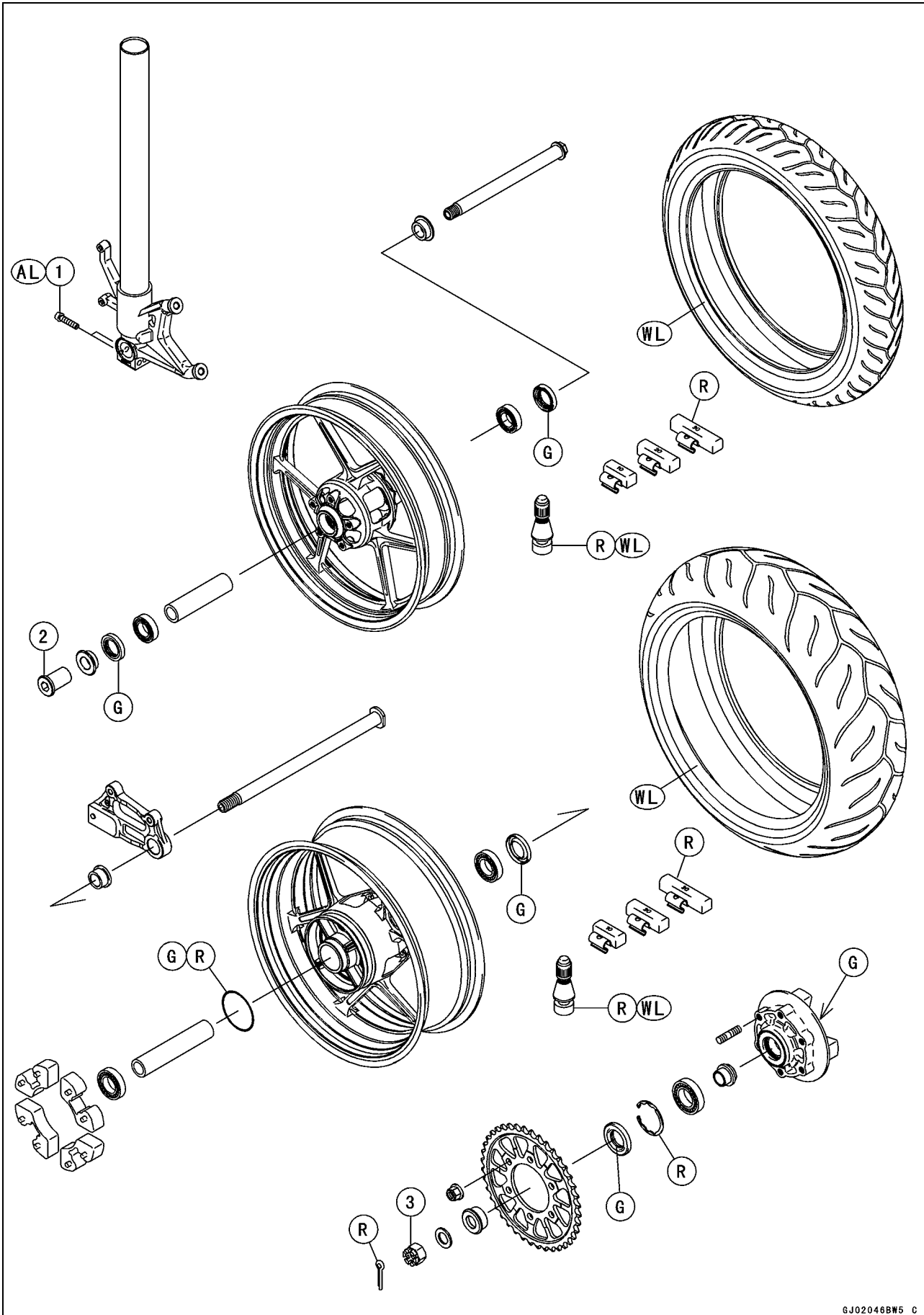

**Exploded View**

No.	Fastener	Torque			Remarks
		N·m	kgf·m	ft·lb	
1	Front Axle Clamp Bolts	20	2.0	14.5	AL
2	Front Axle Nut	108	11	81	
3	Rear Axle Nut	108	11	81	

AL: Tighten the two clamp bolts alternately two time to ensure even tightening.

G: Apply grease.

R: Replacement Parts

WL: Apply soap and water solution or rubber lubricant.

## 10-4 WHEELS/TIRES

### Specifications

Item	Standard	Service Limit
<b>Wheels (Rims)</b>		
Rim Runout:		
Axial	---	0.5 mm (0.02 in.)
Radial	---	0.8 mm (0.03 in.)
Axle Runout/100 mm	0.03 mm (0.0012 in.) or less	0.2 mm (0.01 in.)
Wheel Balance	10 g (0.35 oz.) or less	---
Balance Weights	10 g (0.35 oz.), 20 g (0.71 oz.), 30 g (1.06 oz.)	---
<b>Tires</b>		
Air Pressure (When Cold):		
Front	Up to 180 kg (396 lb) load: 250 kPa (2.5 kgf/cm <sup>2</sup> , 36 psi)	---
Rear	Up to 180 kg (396 lb) load: 290 kPa (2.9 kgf/cm <sup>2</sup> , 41 psi)	---
Tread Depth:		
Front	4.0 mm (0.16 in.)	1 mm (0.04 in.) (AU, CH, DE) 1.6 mm (0.06 in.)
Rear	5.5 mm (0.22 in.)	Up to 130 km/h (80 mph): 2 mm (0.08 in.) Over 130 km/h (80 mph): 3 mm (0.12 in.)
Standard Tires:	Make, Type	Size
Front	DUNLOP SPORTMAX RADIAL D218FJ	120/70 ZR17 M/C (58 W)
Rear	DUNLOP SPORTMAX RADIAL D218J	190/50 ZR17 M/C (73 W)

AU: Australia  
 CH: Switzerland  
 DE: Germany

### WARNING

Use the same manufacturer's tires on both front and rear wheels.

Special Tools

Bearing Driver Set:  
57001-1129

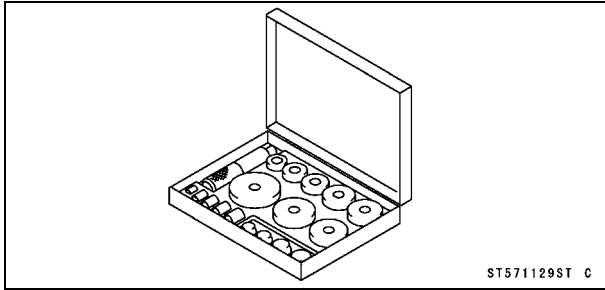

Bearing Remover Head,  $\phi 20 \times \phi 22$ :  
57001-1293

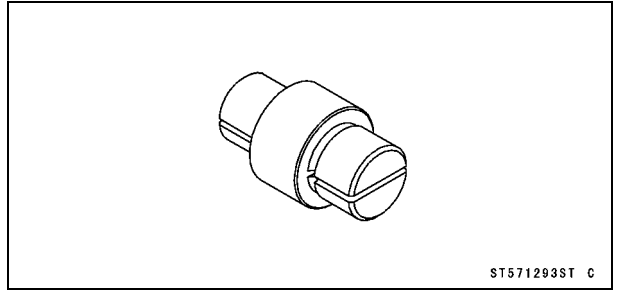

Jack:  
57001-1238

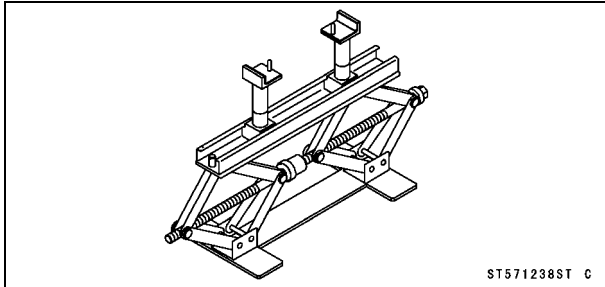

Bearing Remover Shaft,  $\phi 13$ :  
57001-1377

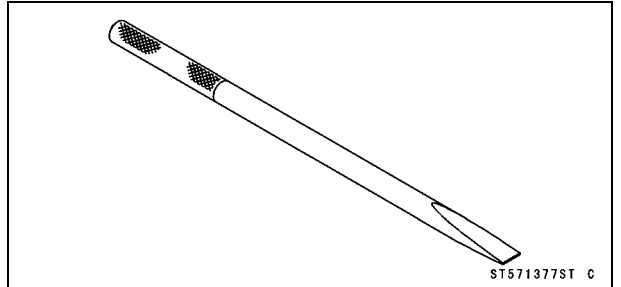

## 10-6 WHEELS/TIRES

### Wheels (Rims)

#### Front Wheel Removal

- Remove:
  - Brake Caliper Mounting Bolts [A]
  - Front Brake Calipers [B]
  
- Loosen:
  - Left Side Axle Clamp Bolts [A]
  - Axle Nut [B]
  - Right Side Axle Clamp Bolts
  
- Raise the front wheel off the ground.
  - Put a wooden board on the jack [A] and lift the jack under the manifold.
  - Special Tool - Jack: 57001-1238**
- Remove the axle nut and pull out the axle to the right and drop the front wheel out of the forks.

#### CAUTION

Do not lay the wheel down on one of the discs. This can damage or warp the disc. Place blocks under the wheel so that the disc does not touch the ground.

#### Front Wheel Installation

#### NOTE

- The direction of the wheel rotation [A] is shown by an arrow [B] on the wheel spoke.
- Check the wheel rotation mark on the front wheel and install it.

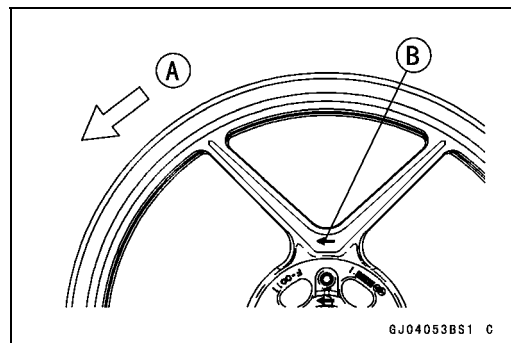
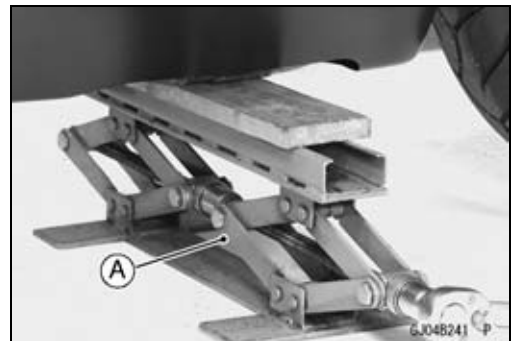
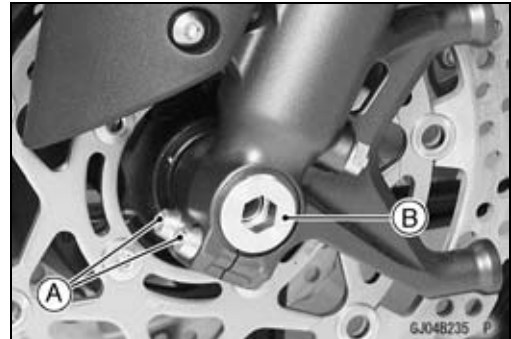
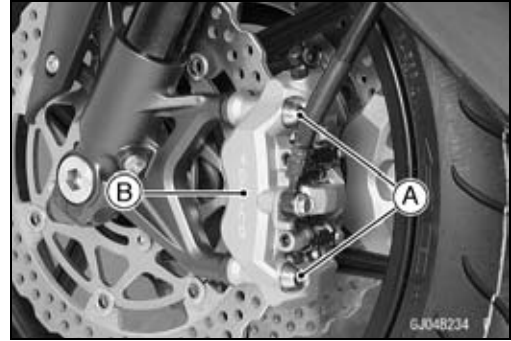

**Wheels (Rims)**

- Apply grease to the grease seal lip.
  - Fit the collars [A] on the both sides of the hub.
  - The collars are identical.
  - Tighten the axle nut [B].
  - Right Axle Clamp Bolts [C]
  - Left Axle Clamp Bolts [D]
  - Viewed from Rear [E]
- Torque - Front Axle Nut: 108 N·m (11 kgf·m, 81 ft·lb)**

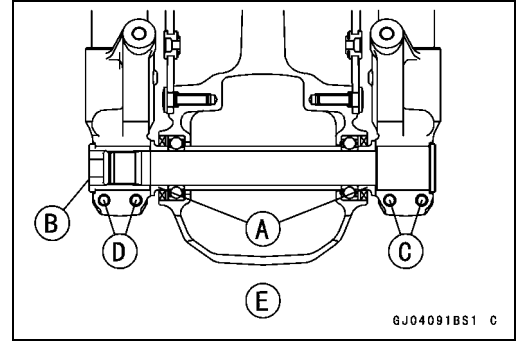

- Before tightening the clamp bolts on the right front fork leg, pump the front fork up and down [A] 4 or 5 times to all on the right front fork leg to seat on the front axle.

**NOTE**

- Put a block in front of the front wheel to stop moving.
  - Tighten the two clamp bolts alternately two times to ensure even tightening torque.
- Tighten the axle clamp bolts on the right fork leg first. Next, tighten the left axle clamp bolts.
- Torque - Front Axle Clamp Bolts: 20 N·m (2.0 kgf·m, 14.5 ft·lb)**



**NOTE**

- Tighten the two clamp bolts alternately two times to ensure even tightening torque.
- Install the front brake calipers (see Brakes chapter).
  - Check the front brake effectiveness (see Brakes chapter).

**⚠ WARNING**

**Do not attempt to drive the motorcycle until a full brake lever is obtained by pumping the brake lever until the pads are against the disc. The brake will not function on the first application of the lever if this is not done.**

*Rear Wheel Removal*

- Raise the rear wheel off the ground with the stand [A].



## 10-8 WHEELS/TIRES

### Wheels (Rims)

- Remove:  
Rear Caliper Mounting Bolts [A]  
Rear Caliper [B]

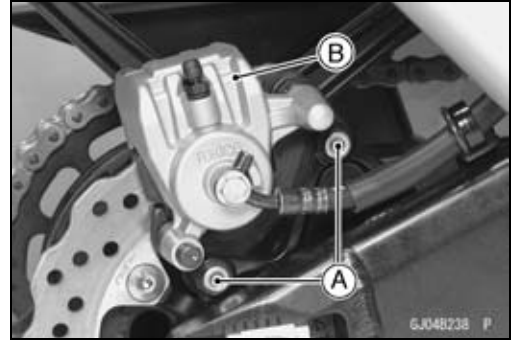

- Remove:  
Cotter Pin [A]  
Axle Nut [B]  
Axle [C] (from Right Side)

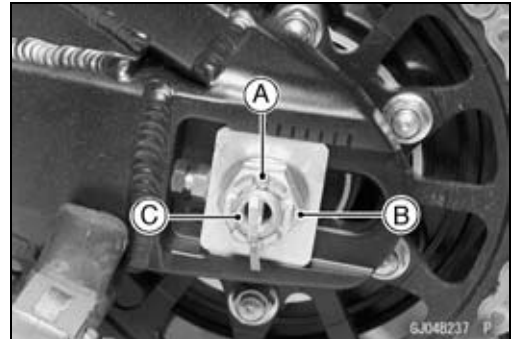

- Remove the drive chain [A] from the rear sprocket toward the left.
- Move the rear wheel back and remove it.

#### CAUTION

Do not lay the wheel on the ground with the disc facing down. This can damage or warp the disc. Place blocks under the wheel so that the disc does not touch the ground.



#### Rear Wheel Installation

- Fit the collars on the both sides of the hub.  
Right Side Collar [A] (with Flange)  
Left Side Collar [B]



- If the coupling [A] is removed from the rear wheel, apply the grease [B] as shown.  
Wheel Flange Portion [C]  
O-ring [D]

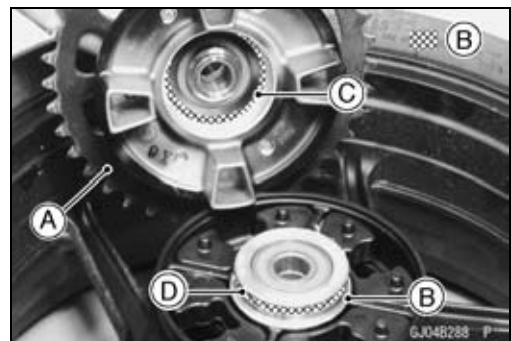



**Wheels (Rims)**

- Engage the drive chain with the rear sprocket.
- Install the caliper bracket [A] onto the swingarm stop [B].
- Insert the axle from the right side of the wheel, and tighten the axle nut.

**Torque - Rear Axle Nut: 108 N·m (11 kgf·m, 81 ft·lb)**

- Adjust the drive chain slack after installation (see Drive Chain Slack Inspection in the Periodic Maintenance chapter).

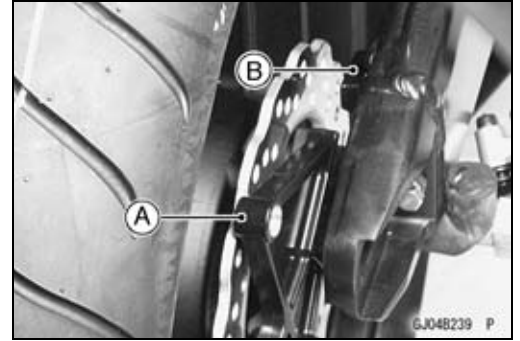

- Insert a new cotter pin [A].

**NOTE**

- When inserting the cotter pin, if the slots in the nut do not align with the cotter pin hole in the axle, tighten the nut clockwise [B] up to next alignment.
- It should be within 30 degree.
- Loosen once and tighten again when the slot goes past the nearest hole.

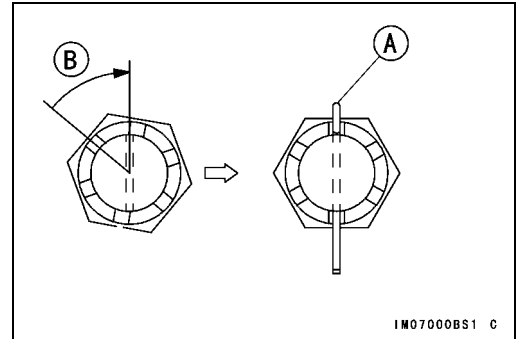

- Install the rear caliper, chain cover and inner fender.
- Check the rear brake effectiveness.

**⚠ WARNING**

**Do not attempt to drive the motorcycle until a full brake pedal is obtained by pumping the brake pedal until the pads are against the disc. The brake will not function on the first application of the pedal if this is not done.**

- Bend the cotter pin [A] over the nut.

**⚠ WARNING**

**If the rear axle nut is not securely tightened or the cotter pin is not installed, an unsafe riding condition may result.**

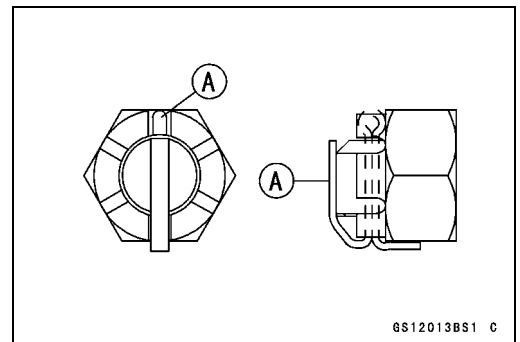

# 10-10 WHEELS/TIRES

## Wheels (Rims)

### Wheel Inspection

- Raise the front/rear wheel off the ground.

**Special Tool - Jack: 57001-1238**

- Spin the wheel lightly, and check for roughness or binding.
- ★ If roughness or binding is found, replace the hub bearings.
- Inspect the wheel for small cracks, dents, bending, or warp.
- ★ If there is any damage to the wheel, replace the wheel.
- Remove the wheel, and support it without the tire by the axle.
- Measure the rim runout, radial [A] and axial [B], with a dial gauge.
- ★ If rim runout exceeds the service limit, check the hub bearings.
- ★ If the problem is not due to the bearings, replace the wheel.

### Rim Runout

#### Service Limit:

Axial	0.5 mm (0.02 in.)
Radial	0.8 mm (0.03 in.)

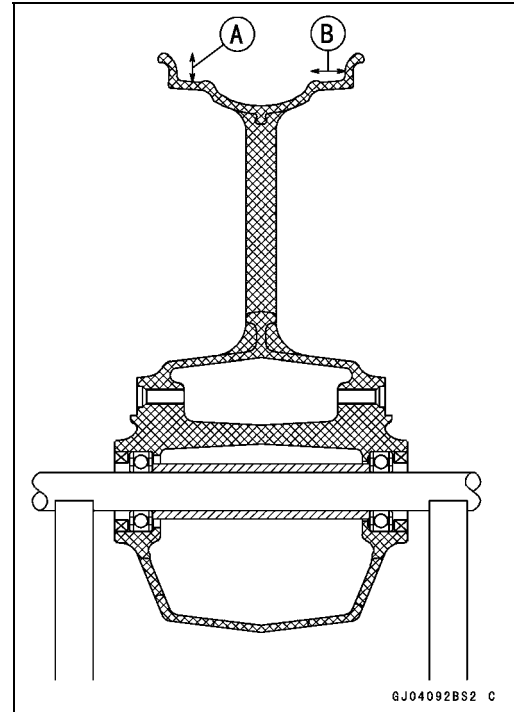

## ⚠ WARNING

Never attempt to repair a damaged wheel. If there is any damage besides wheel bearings, the wheel must be replaced to insure safe operational condition.

### Axle Inspection

- Remove the front and rear axles.
- Visually inspect the front and rear axle for damages.
- ★ If the axle is damaged or bent, replace it.
- Place the axle in V blocks that are 100 mm (3.94 in.) [A] apart, and set a dial gauge [B] on the axle at a point halfway between the blocks. Turn [C] the axle to measure the runout. The difference between the highest and lowest dial readings is the amount of runout.
- ★ If axle runout exceeds the service limit, replace the axle.

### Axle Runout/100 mm (3.94 in.)

Standard:	0.03 mm (0.0012 in.) or less
Service Limit:	0.2 mm (0.01 in.)

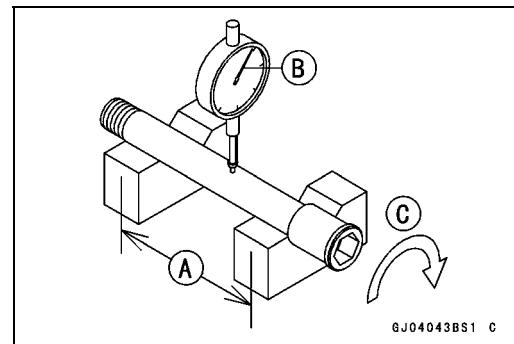

### Balance Inspection

- Remove the wheel.
- Support the wheel so that it can be spun freely.
- Spin the wheel lightly, and mark [A] the wheel at the top when the wheel stops.
- Repeat this procedure several times. If the wheel stops of its own accord in various positions, it is well balanced.
- ★ If the wheel always stops in one position, adjust the wheel balance.

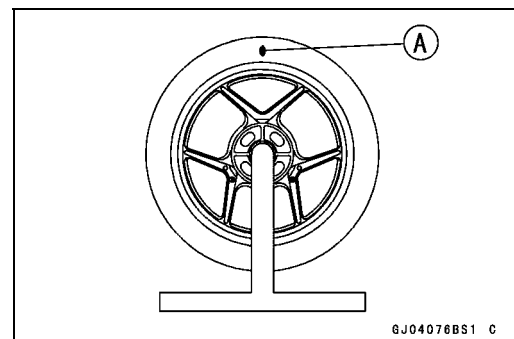

**Wheels (Rims)**

*Balance Adjustment*

- If the wheel always stops in one position, provisionally attach a balance weight [A] on the rim at the marking using adhesive tape.
- Rotate the wheel 1/4 turn [B], and see whether or not the wheel stops in this position. If it does, the correct balance weight is being used.
- ★ If the wheel rotates and the weight goes up, replace the weight with the next heavier size. If the wheel rotates and the weight goes down, replace the weight with the next lighter size. Repeat these steps until the wheel remains at rest after being rotated 1/4 turn.
- Rotate the wheel another 1/4 turn and then another 1/4 turn to see if the wheel is correctly balanced.
- Repeat the entire procedure as many times as necessary to achieve correct wheel balance.
- Permanently install the balance weight.

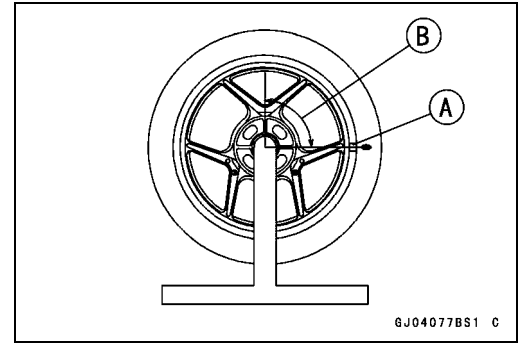

*Balance Weight Removal*

- Insert a regular tip screw drivers [A] [B] between the rib [C] and weight [D] as shown.
- Pry the balance weight with two screw drivers and remove the balance weight.
- Discard the used balance weight.

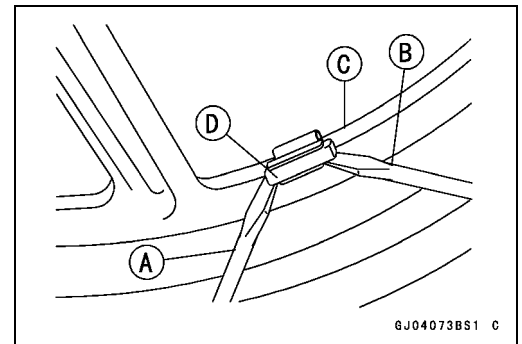

**CAUTION**

**Do not tap the screwdrivers. The rim could be damaged.**

*Balance Weight Installation*

- Check if the weight portion has any play on the blade [A] and clip [B].
- ★ If it does, discard it.

**⚠ WARNING**

**If the balance weight has any play on the rib of the rim, the blade and/or clip have been stretched. Replace the loose balance weight. Do not reuse used balance weight. Unbalanced wheels can create an unsafe riding condition.**

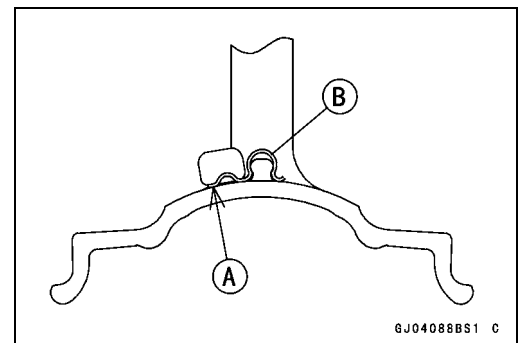

**Balance Weight**

Part Number	Weight
41075-0007	10 g (0.35 oz)
41075-0008	20 g (0.71 oz)
41075-0009	30 g (1.06 oz)

**NOTE**

- Balance weights are available from Kawasaki dealers in 10, 20, and 30 gram (0.35 oz, 0.71 oz, and 1.06 oz) sizes. An imbalance of less than 10 grams (0.35 oz) will not usually affect running stability.
- Do not use four or more balance weight (more than 90 gram). If the wheel requires an excess balance weight, disassemble the wheel to find the cause.

## 10-12 WHEELS/TIRES

### Wheels (Rims)

- Slip the balance weight [A] on to the rib [B], by pushing or lightly hammering [C] the clip [D].

Left Side [E]

Right Side [F]

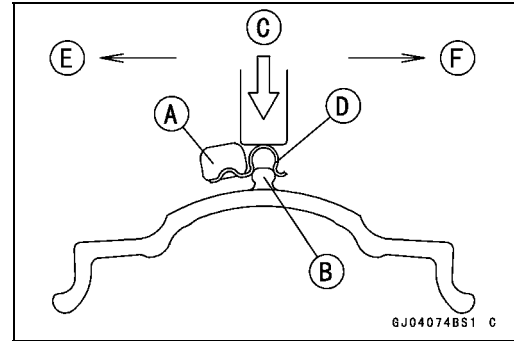

- Be sure to install the balance weight.
- Check that the blade [A] and clip [B] are fully seated on the rim [C] and that the clip is hooked over the rib [D].

Left Side [E]

Right Side [F]

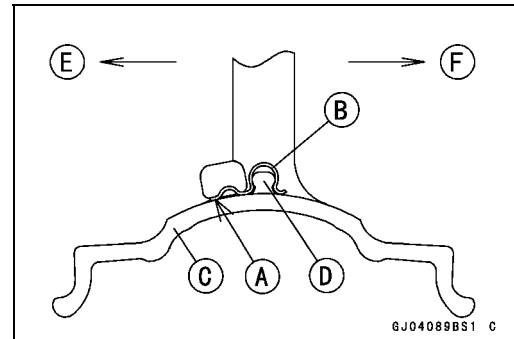

**Tires**

*Air Pressure Inspection/Adjustment*

- Refer to the Tires Air Pressure Inspection in the Periodic Maintenance chapter.

*Tire Inspection*

- Refer to the Wheels/Tires Damage Inspection in the Periodic Maintenance chapter.

*Tire Removal*

- Remove:
  - Wheel (see this chapter)
  - Disc(s)
  - Valve Core (let out the air)
- To maintain wheel balance, mark the valve stem position on the tire with chalk so that the tire can be reinstalled in the same position.
  - Chalk Mark or Yellow Mark [A]
  - Air Valve [B]
  - Align [C]

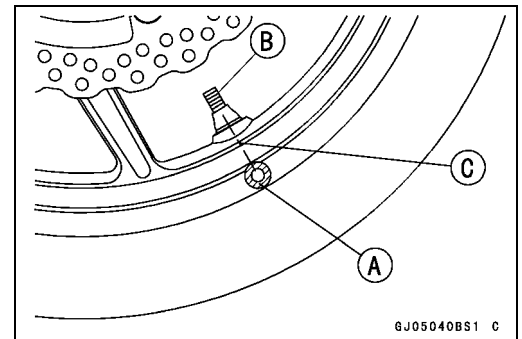

- Lubricate the tire beads and rim flanges on both sides with a soap and water solution or rubber lubricant. This helps the tire beads slip off the rim flanges.

**CAUTION**

**Never lubricate with engine oil or petroleum distillates because they will deteriorate the tire.**

- Remove the tire from the rim using a suitable commercially available tire changer.

**NOTE**

○ *The tires cannot be removed with hand tools because they fit the rims too tightly.*

*Tire Installation*

**⚠ WARNING**

**Use the same manufacturer's on both front and rear wheels.**

- Inspect the rim and tire, and replace them if necessary.
- Clean the sealing surfaces of the rim and tire, and smooth the sealing surfaces of the rim with a fine emery cloth if necessary.
- Remove the air valve and discard it.

**CAUTION**

**Replace the air valve whenever the tire is replaced. Do not reuse the air valve.**

## 10-14 WHEELS/TIRES

### Tires

- Install a new valve in the rim.
- Remove the valve cap, lubricate the stem seal [A] with a soap and water solution or rubber lubricant, and pull [B] the valve stem through the rim from the inside out until it snaps into place.

#### CAUTION

**Do not use engine oil or petroleum distillates to lubricate the stem because they will deteriorate the rubber.**

- The air valve is shown in the figure.

- [A] Valve Cap
- [B] Valve Core
- [C] Stem Seal
- [D] Valve Stem
- [E] Valve Seat
- [F] Valve Opened

- Apply a soap and water solution, or rubber lubricant to the rim flange and tire beads.
- Check the tire rotation mark on the front and rear tires and install them on the rim accordingly.
  - Tire Rotation Mark [A]
  - Rotating Direction [B]

- Position the tire on the rim so that the valve [A] align with the tire balance mark [B] (the chalk mark made during removal, or the yellow paint mark on a new tire).
- Install the tire bead over the rim flange using a suitable commercially available tire changer.
- Lubricate the tire beads and rim flanges with a soap and water solution or rubber lubricant to help seat the tire beads in the sealing surfaces of the rim while inflating the tire.
- Center the rim in the tire beads, and inflate the tire with compressed air until the tire beads seat in the sealing surfaces.

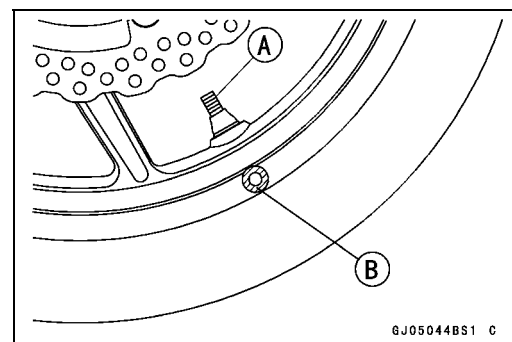
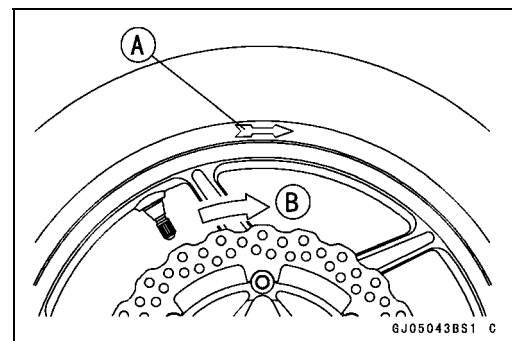
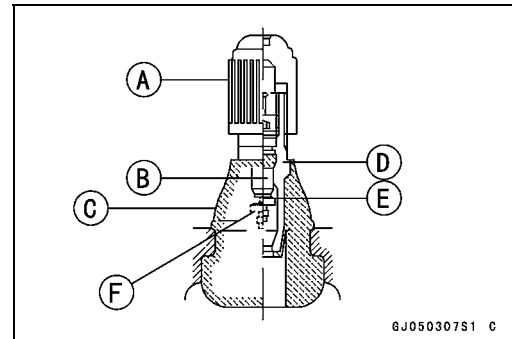
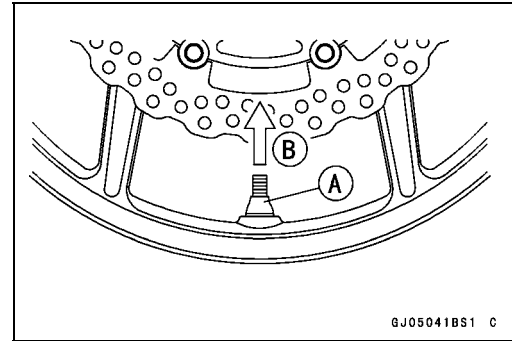

#### **⚠ WARNING**

**Be sure to install the valve core whenever inflating the tire, and do not inflate the tire to more than 400 kPa (4.0 kgf/cm<sup>2</sup>, 57 psi). Overinflation can explode the tire with possibility of injury and loss of life.**

## Tires

- Check to see that the rim lines [A] on both sides of the tire sidewalls are parallel with the rim flanges.
- ★ If the rim flanges and tire sidewall rim lines are not parallel, remove the valve core.
- Lubricate the rim flanges and tire beads.
- Install the valve core and inflate the tire again.
- After the tire beads seat in the rim flanges, check for air leakage.
- Inflate the tire slightly above standard inflation.
- Use a soap and water solution or submerge the tire, and check for bubbles that would indicate leakage.
- Adjust the air pressure to the specified pressure (see Tire Inspection).
- Install the air valve cap.
- Install the brake disc(s) so that the marked side faces out (see Brakes chapter).
- Adjust the wheel balance (see Balance Adjustment).

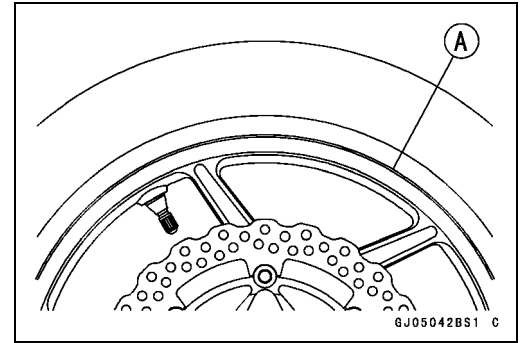

### *Tire Repair*

Currently two types of repair for tubeless tires have come into wide use. One type is called a temporary (external) repair which can be carried out without removing the tire from the rim, and the other type is called permanent (internal) repair which requires tire removal. It is generally understood that higher running durability is obtained by permanent (internal) repairs than by temporary (external) ones. Also, permanent (internal) repairs have the advantage of permitting a thorough examination for secondary damage not visible from external inspection of the tire. For these reasons, Kawasaki does not recommend temporary (external) repair. Only appropriate permanent (internal) repairs are recommended. Repair methods may vary slightly from make to make. Follow the repair methods indicated by the manufacturer of the repair tools and materials so that safe results can be obtained.

# 10-16 WHEELS/TIRES

## Hub Bearing

### Hub Bearing Removal

- Remove the wheel, and take out the following.
  - Collars
  - Coupling (out of rear hub)
  - Grease Seals
- Use the bearing remover to remove the hub bearing [A].

### CAUTION

Do not lay the wheel on the ground with the disc facing down. This can damage or warp the disc. Place blocks under the wheel so that the disc does not touch the ground.

Special Tools - Bearing Remover Shaft,  $\phi 13$ : 57001-1377 [B]  
Bearing Remover Head,  $\phi 20 \times \phi 22$ : 57001-1293 [C]

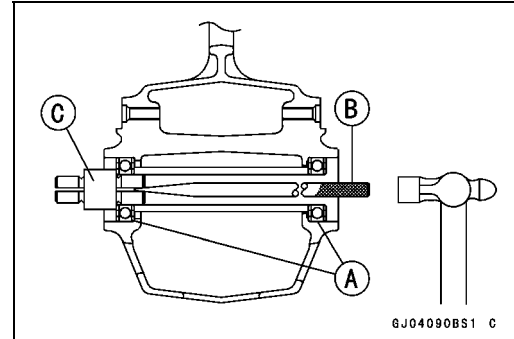

### Hub Bearing Installation

- Before installing the wheel bearings, blow any dirt or foreign particles out of the hub with compressed air to prevent contamination of the bearings.
- Replace the bearings with new ones.

### NOTE

○ Install the bearings so that the marked side faces out.

- Install the bearings by using the bearing driver set which does not contact the bearing inner race.
- Press in each right the bearing [A] until they are bottomed.

Special Tool - Bearing Driver Set: 57001-1129 [B]

- Replace the grease seals with new ones.
  - Press in the grease seals [A] so that the seal surface is flush [B] with the end of the hole.
- Apply high temperature grease to the grease seal lips.

Special Tool - Bearing Driver Set: 57001-1129 [C]

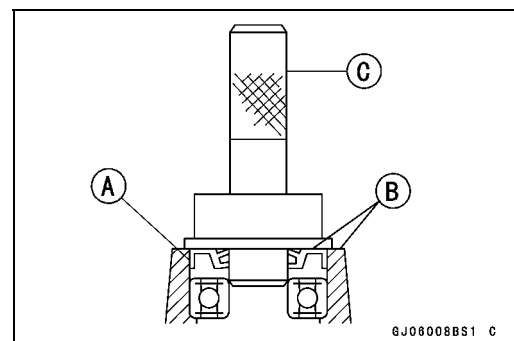
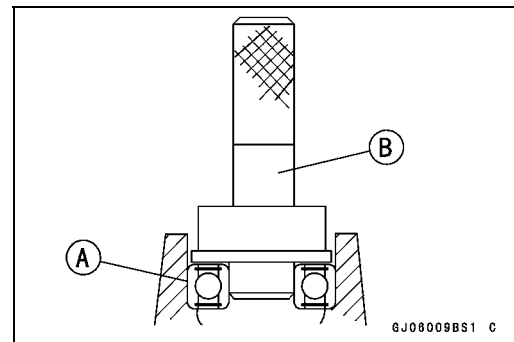

### Hub Bearing Inspection

Since the hub bearings are made to extremely close tolerances, the clearance can not normally be measured.

### NOTE

○ Do not remove any bearings for inspection. If any bearings are removed, they will need to be replaced with new ones.

- Turn each bearing in the hub back and forth [A] while checking for plays, roughness, or binding.
- ★ If bearing play, roughness, or binding is found, replace the bearing.
- Examine the bearing seal [B] for tears or leakage.
- ★ If the seal is torn or is leaking, replace the bearing.

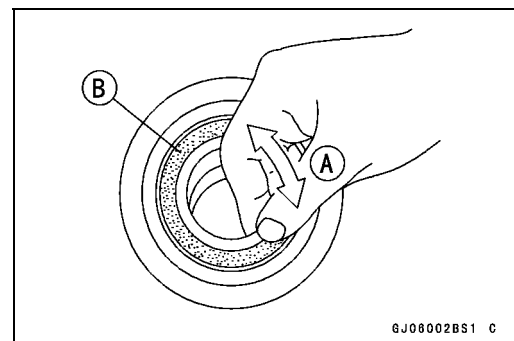



## Hub Bearing

---

### *Hub Bearing Lubrication*

#### **NOTE**

- *Since the hub bearings are packed with grease and sealed, lubrication is not required.*



# Final Drive

## Table of Contents

Exploded View .....	11-2
Specifications .....	11-4
Special Tools .....	11-5
Drive Chain.....	11-6
Drive Chain Slack Inspection .....	11-6
Drive Chain Slack Adjustment .....	11-6
Wheel Alignment Inspection/Adjustment .....	11-6
Drive Chain Wear Inspection .....	11-6
Drive Chain Lubrication.....	11-6
Drive Chain Removal .....	11-6
Drive Chain Installation .....	11-8
Sprocket, Coupling .....	11-10
Engine Sprocket Removal .....	11-10
Engine Sprocket Installation .....	11-10
Rear Sprocket Removal.....	11-11
Rear Sprocket Installation.....	11-11
Coupling Installation.....	11-11
Coupling Bearing Removal .....	11-12
Coupling Bearing Installation .....	11-12
Coupling Bearing Inspection .....	11-12
Coupling Bearing Lubrication.....	11-12
Coupling Damper Inspection.....	11-13
Sprocket Wear Inspection.....	11-13
Rear Sprocket Warp Inspection .....	11-13



**Exploded View**

No.	Fastener	Torque			Remarks
		N·m	kgf·m	ft·lb	
1	Speed Sensor Bolt	4.0	0.40	35 in·lb	L
2	Engine Sprocket Cover Bolts	9.8	1.0	87 in·lb	
3	Engine Sprocket Nut	127	13	94	MO
4	Rear Axle Nut	108	11	81	
5	Rear Sprocket Nuts	59	6.0	43	
6	Chain Guide Bolts	9.8	1.0	87 in·lb	

G: Apply grease.

HO: Apply heavy oil.

L: Apply a non-permanent locking agent.

MO: Apply molybdenum disulfide oil (mixture of engine oil and molybdenum disulfide grease in a weight ratio is 10 : 1).

R: Replacement Parts

## 11-4 FINAL DRIVE

### Specifications

Item	Standard	Service Limit
<b>Drive Chain</b> Standard Chain Make Type Link	RK EXCEL RK 525MFO, Endless 110 links	--- --- ---
<b>Sprockets</b> Rear Sprocket Warp	0.4 mm (0.016 in.) or less	0.5 mm (0.02 in.)

**Special Tools**

**Inside Circlip Pliers:**  
**57001-143**

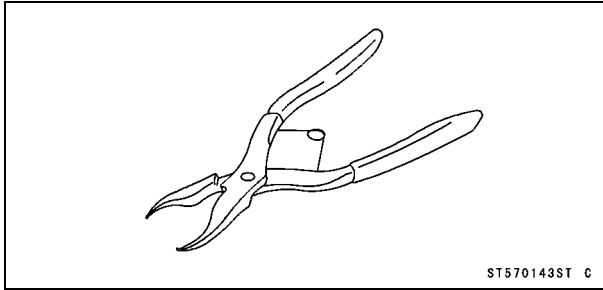

**Bearing Driver Set:**  
**57001-1129**

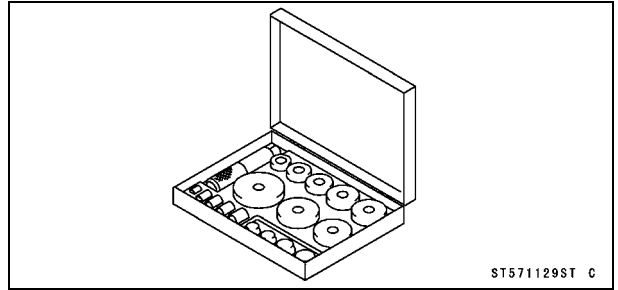

## 11-6 FINAL DRIVE

### Drive Chain

#### *Drive Chain Slack Inspection*

- Refer to the Drive Chain Slack Inspection in the Periodic Maintenance chapter.

#### *Drive Chain Slack Adjustment*

- Refer to the Drive Chain Slack Inspection in the Periodic Maintenance chapter.

#### *Wheel Alignment Inspection/Adjustment*

- Refer to the Wheel Alignment Inspection in the Periodic Maintenance chapter.

#### *Drive Chain Wear Inspection*

- Refer to the Drive Chain Wear Inspection in the Periodic Maintenance chapter.

#### *Drive Chain Lubrication*

- Refer to the Drive Chain Lubrication Condition in the Periodic Maintenance chapter.

#### *Drive Chain Removal*

#### **NOTE**

○ Since the drive chain is installed through the swingarm, The chain cannot be removed other than by cutting it. Prepare the new link pin, link plate, grease seals, and tools for rejoining the chain.

- Using a suitable tool [A], cut the drive chain by removing the link pins.

**Recommended Tool: RK EXCEL 70 Tool (RK-700)**

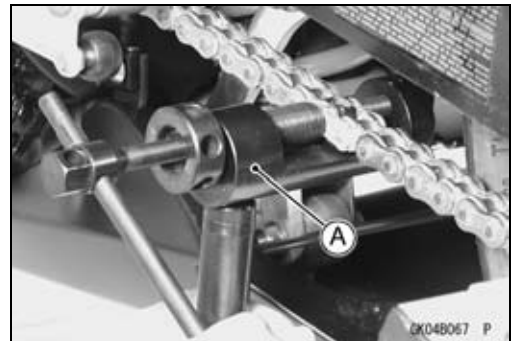

#### **CAUTION**

**Read the Tool Manual before removing.**

- Pressure Bolt (A) [A]
- Pressure Bolt (B) [B]
- Handle Lever [C]
- Pressure Holder [D]
- Guide Plate [E]
- Adjuster Bolt (Yellow) [F]
- Wedge Holder [G] & Weigh Pin
- Grip Handle [H]
- Flare Pin [I]
- Cap [J]
- Adjuster Bolt [K]
- Pin Puller [L]
- Body [N]
- Cap Bolt [M]

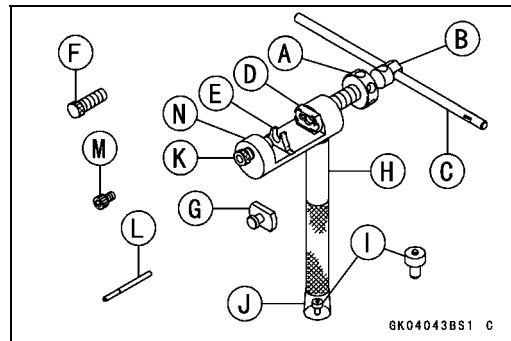



**Drive Chain**

- Install the guide plate [A] on the body [B].
- Screw the cap bolt [C].
- Install the grip handle.

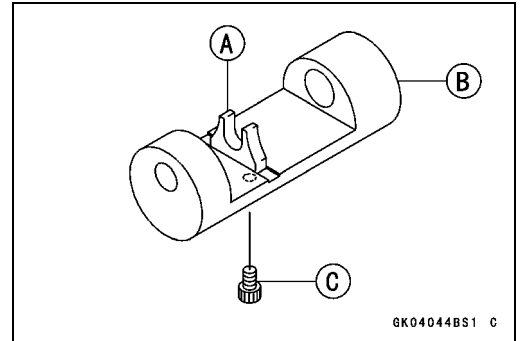

- Set the chain [A] to the guide plate [B].
- Screw in the adjuster bolt [C] for holding the chain.
- Screw in the pressure bolt (A) [D] for holding the chain.

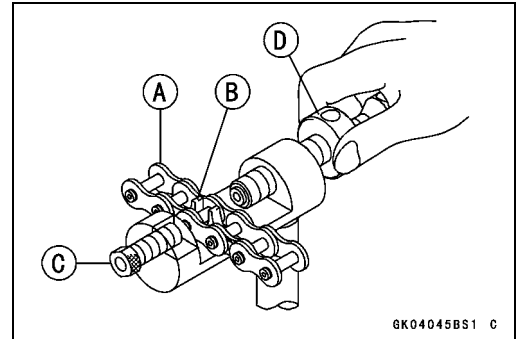

- Insert the pin puller [A] to the pressure bolt (B) [B].

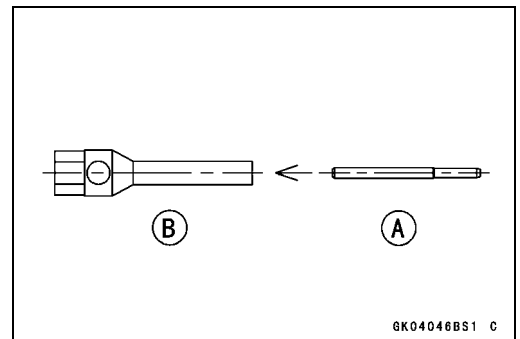

- Screw in the pressure bolt assy [A] in the pressure bolt (A) [B].
- Install the handle lever [C] to the pressure bolt assy.
- Turn in the handle lever until the link pin [D] removed at the link plate [E].

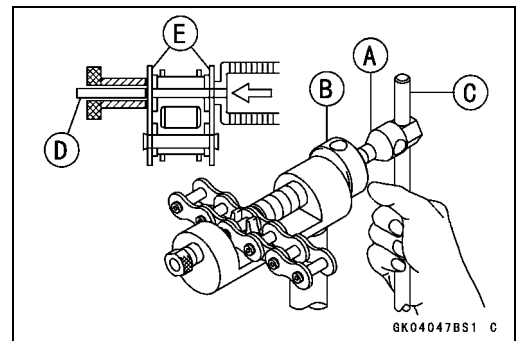

- Repeat the above steps for other link pin [A].

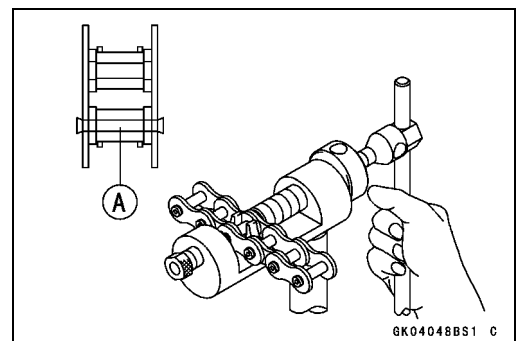

# 11-8 FINAL DRIVE

## Drive Chain

### Drive Chain Installation

- Engage new drive chain to the old drive chain and pull the end of the old drive chain until they are changing the position.
- Remove the old drive chain from the new drive chain.
- Apply grease to the link pins [A] and grease seals.
- Engage the drive chain on the rear sprocket through the swingarm.
- Install the grease seals [B] on the link pins.
- Insert the link pins in the drive chain ends.
- Install:
  - Grease Seals [C]

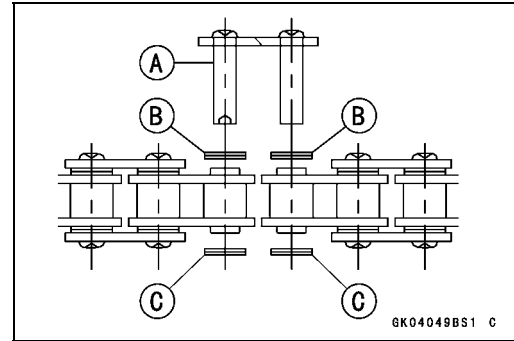

- Set the adjuster bolt (Yellow) [A], wedge holder & wedge pin [B], and pressure holder [C] on the body [D].
- Hold the wedge holder & wedge pin, using the adjuster bolt (Yellow).
- Apply grease to the inside [E] of the pressure holder.

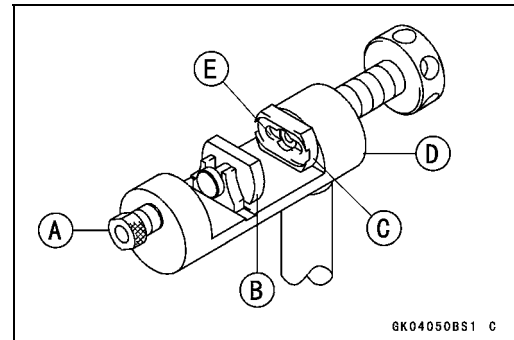

- Install the link plate so that the gold painted [A] faces out.

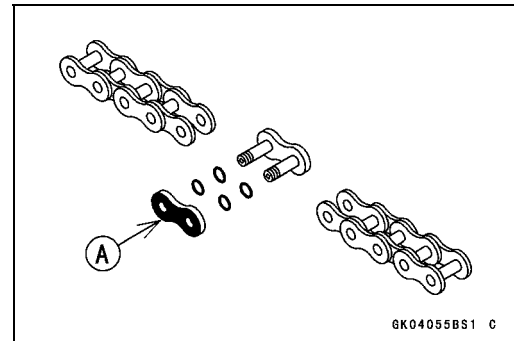

- Fit the link plate [A] in the pressure holder [B].
- Fit the link plates of the chain into the wedge holder & wedge pin [D].
- Turn the pressure bolt (A) [C] by hand until link plate touches the link pins.

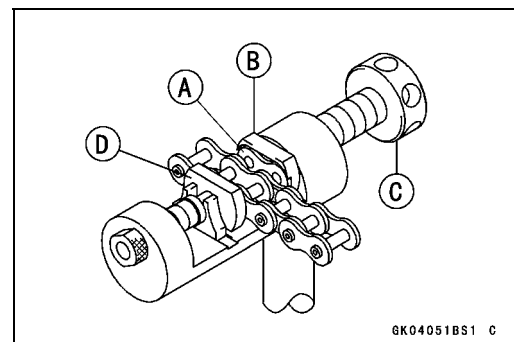

**Drive Chain**

- Install the handle lever [A] onto the pressure bolt (A) [B].
- Turn the handle lever, press in the link plate to the link pins.

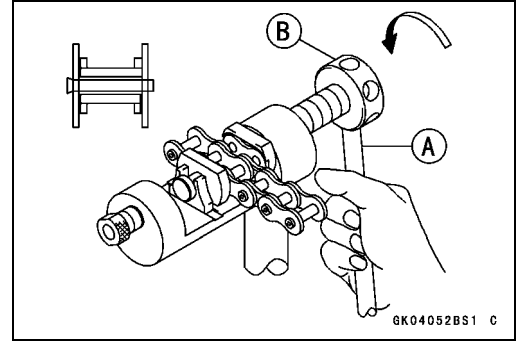

- Set the adjuster bolt (Yellow) [A], guide plate [B], and flare pin [C] on the body.
- Apply grease to the tip [D] of the flare pin.
- Fit the adjuster bolt (Yellow) to the link pin [E].

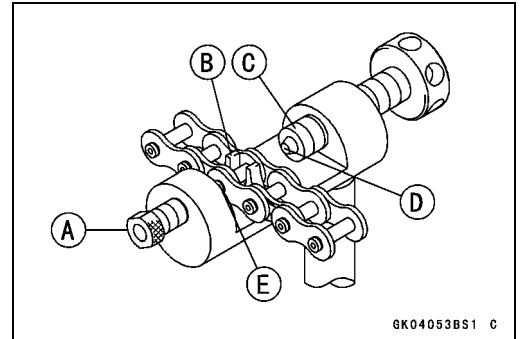

- Install the grip lever [A] onto the pressure bolt (A) [B].
- Stake the link pin end by the handle lever about 9/10 turns [C].
- Repeat the above steps for other link pin [D].

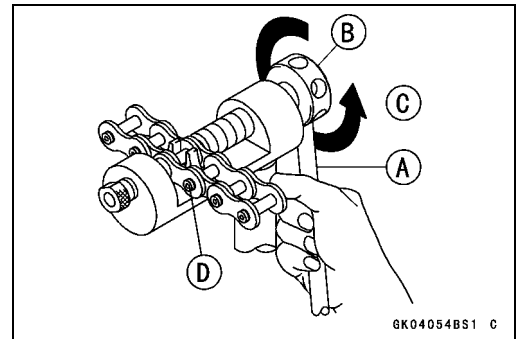

- After staking, measure the outside diameter [A] of the link pin and link plates width [B].

**Link Pin Outside Diameter**

Standard: 5.60 ~ 5.90 mm (0.22 ~ 0.23 in.)

**Link Plates Outside Width**

Standard: 19.70 ~ 20.00 mm (0.775 ~ 0.787 in.)

- ★ If the reading exceeds the specified length, cut and rejoin the chain again.

- Check:
  - Movement of the Rollers
- Adjust the drive chain slack after installing the chain (see Drive Chain Slack Inspection in the Periodic Maintenance chapter).

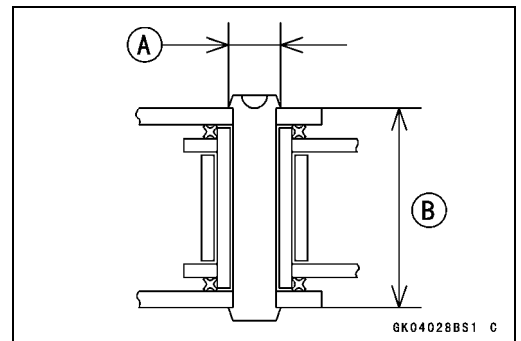

## 11-10 FINAL DRIVE

### Sprocket, Coupling

#### Engine Sprocket Removal

- Remove:
  - Speed Sensor Bolt [A]
  - Speed Sensor [B]
  - Engine Sprocket Cover Bolts [C]
  - Engine Sprocket Cover [D]

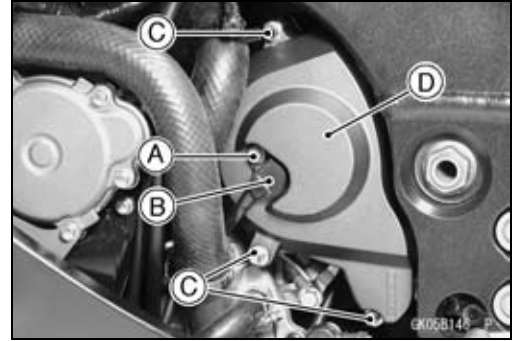

- Flatten out the bended washer [A].
- Remove the engine sprocket nut [B] and washer.

#### NOTE

○When loosening the engine sprocket nut, hold the rear brake on.

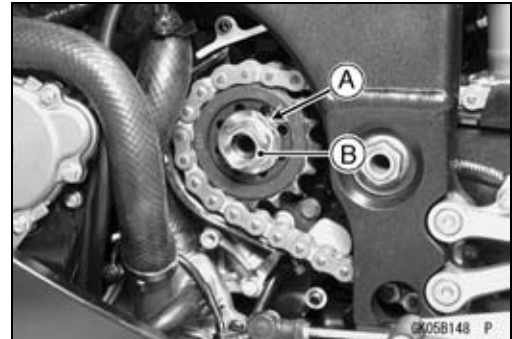

- Raise the rear wheel off the ground.
- Remove the axle cotter pin, and loosen the rear axle nut.
- Loosen the both chain adjuster locknut to loosen the drive chain.
- Remove the drive chain from the rear sprocket toward the right.
- Pull the engine sprocket [A] with drive chain [B] off the output shaft [C].
- Disengage the drive chain from the engine sprocket.

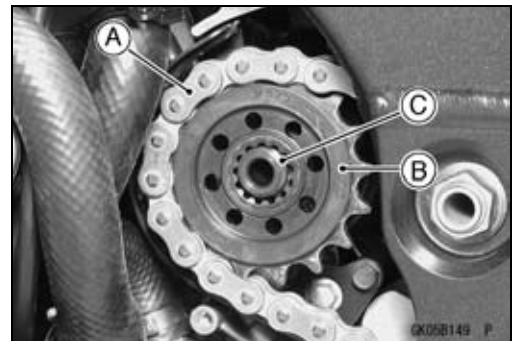

#### Engine Sprocket Installation

- Replace the sprocket washer and axle cotter pin.
- Install the engine sprocket onto the shaft so that the mark side [A] faces outwards.
- Apply molybdenum disulfide oil to the threads of the output shaft and the seating surface of the engine sprocket nut.
- After torquing the engine sprocket nut, bend [B] the one side of the washer over the nut.

#### NOTE

○Tighten the nut while applying the rear brake.

**Torque - Engine Sprocket Nut: 125 N·m (13.0 kgf·m, 92 ft·lb)**

- Adjust the drive chain slack after installing the sprocket (see Final Drive in the Periodic Maintenance chapter).

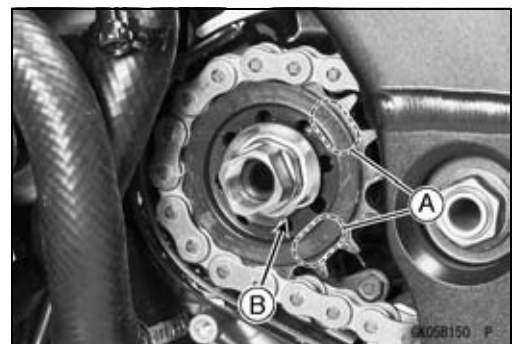

## Sprocket, Coupling

- Install the engine sprocket cover.
- Install dampers [A] and washer [B] to one cover bolt [C].
- Torque - Engine Sprocket Cover Bolts: 9.8 N·m (1.0 kgf·m, 87 in·lb)**
- Apply a non-permanent locking agent: Speed Sensor Bolt
- Torque - Speed Sensor Bolt: 4.0 N·m (0.40 kgf·m, 35 in·lb)**
- Bend the end of axle cotter pin surely after tightening the axle nut.

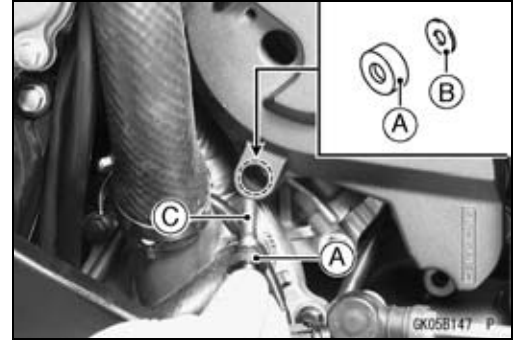

### Rear Sprocket Removal

- Remove the rear wheel (see Wheels/Tires chapter).

#### CAUTION

**Do not lay the wheel on the ground with the disc facing down. This can damage or warp the disc. Place blocks under the wheel so that the disc does not touch the ground.**

- Remove the rear sprocket nuts [A].
- Remove the rear sprocket [B].

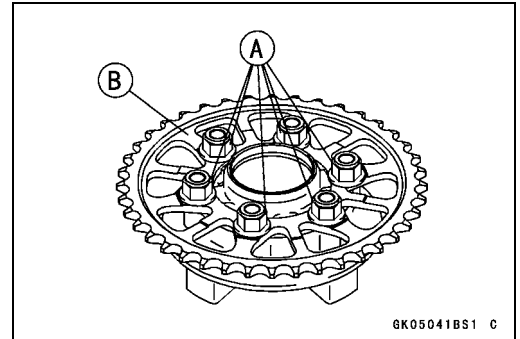

### Rear Sprocket Installation

- Install the sprocket facing the tooth number marking [A] outward.
- Tighten the rear sprocket nuts.
- Torque - Rear Sprocket Nut: 59 N·m (6.0 kgf·m, 43 ft·lb)**
- Install the rear wheel (see Wheels/Tires chapter).

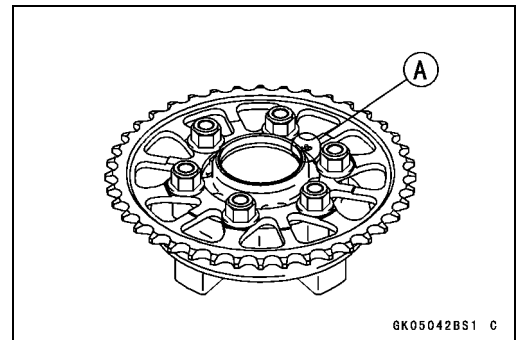

### Coupling Installation

- Grease the following and install the coupling.
  - Coupling Grease Seal Lips [A]
  - Coupling Internal Surface [B]

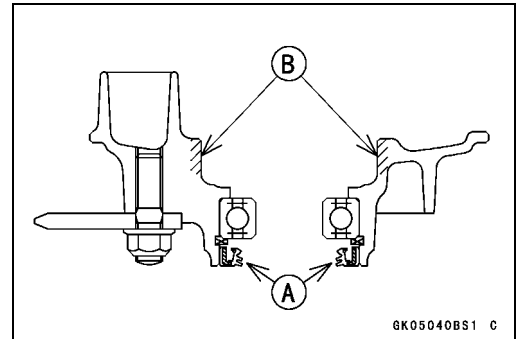

- Apply grease to the O-ring [A].
- Install the collar [B]

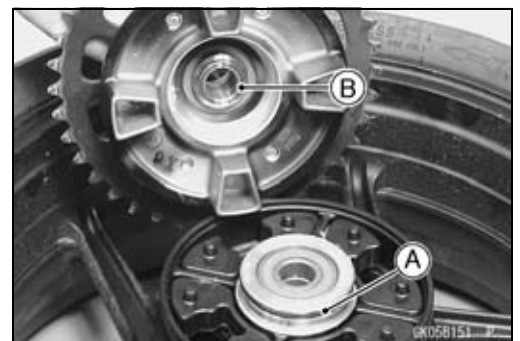

## 11-12 FINAL DRIVE

### Sprocket, Coupling

#### Coupling Bearing Removal

- Remove:
  - Coupling
  - Grease Seal
  - Circlip [A]

**Special Tool - Inside Circlip Pliers: 57001-143 [B]**

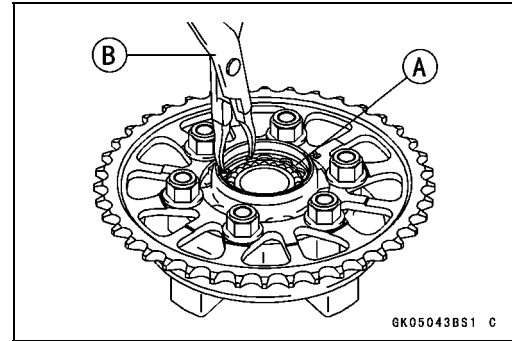

- Remove the bearing [A] by tapping from the wheel side.

**Special Tool - Bearing Driver Set: 57001-1129 [B]**

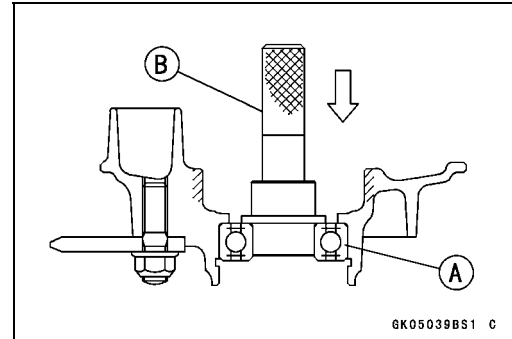

#### Coupling Bearing Installation

- Replace the bearing with a new one.
- Press in the bearing [A] until it is bottomed.

**Special Tool - Bearing Driver Set: 57001-1129 [B]**

- Pack the bearing with high temperature grease.
- Replace the circlip with a new one.

**Special Tool - Inside Circlip Pliers: 57001-143**

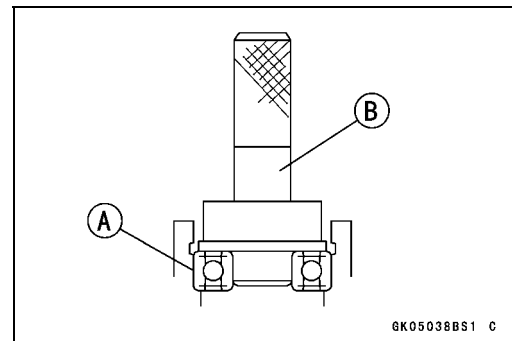

- Replace the grease seal with a new one.
- Press in the grease seal so that the seal surface is flush with the end of the hole.
- Apply high temperature grease to the grease seal lips.

**Special Tool - Bearing Driver Set: 57001-1129**

#### Coupling Bearing Inspection

Since the coupling bearing is made to extremely close tolerances, the clearance can not normally be measured.

#### NOTE

○ It is not necessary to remove the coupling bearing for inspection. If the bearing is removed, it will need to be replaced with a new one.

- Turn the bearing in the coupling back and forth [A] while checking for plays, roughness, or binding.
- ★ If bearing play, roughness, or binding is found, replace the bearing.
- Examine the bearing seal [B] for tears or leakage.
- ★ If the seal is torn or is leaking, replace the bearing.

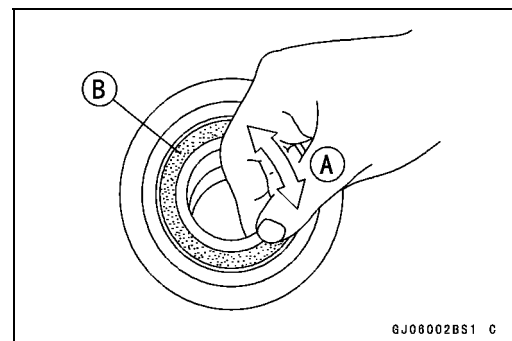

#### Coupling Bearing Lubrication

#### NOTE

○ Since the coupling bearing is packed with grease and sealed, lubrication is not required.

## Sprocket, Coupling

### Coupling Damper Inspection

- Remove the rear wheel coupling, and inspect the rubber dampers [A].
- Replace the damper if it appears damaged or deteriorated.

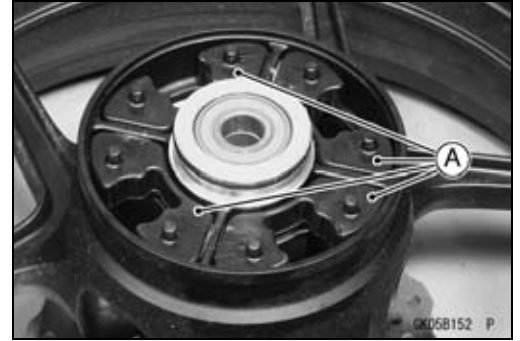

### Sprocket Wear Inspection

- Visually inspect the engine and rear sprocket teeth for wear and damage.
- ★ If the teeth are worn as illustrated, replace the sprocket, and inspect the drive chain wear (see Final Drive in the Periodic Maintenance chapter).
  - Worn Tooth (Engine Sprocket) [A]
  - Worn Tooth (Rear Sprocket) [B]
  - Direction of Rotation [C]

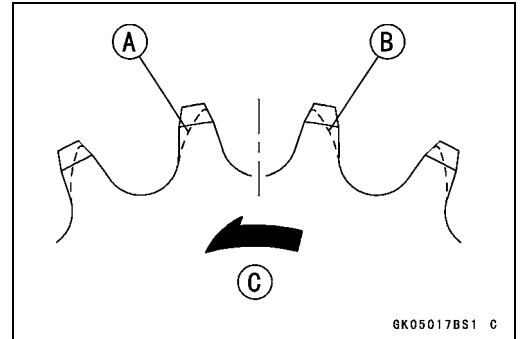

### NOTE

- If a sprocket requires replacement, the chain is probably worn also.
- When replacing a sprocket, inspect the chain.

### Rear Sprocket Warp Inspection

- Raise the rear wheel off the ground (see Wheels/Tires chapter) so that it will turn freely.
- Set a dial gauge [A] against the rear sprocket [B] near the teeth as shown, and rotate [C] the rear wheel to measure the sprocket runout (warp). The difference between the highest and lowest dial gauge readings is the amount of runout (warp).
- ★ If the runout exceeds the service limit, replace the rear sprocket.

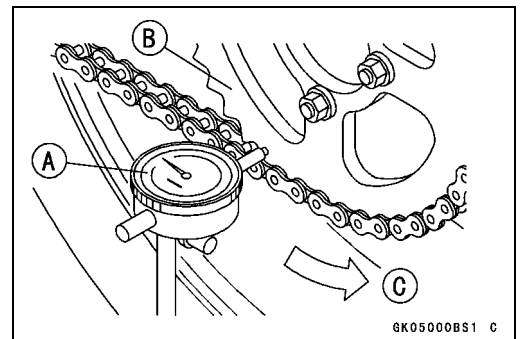

### Rear Sprocket Warp

Standard:	0.4 mm (0.016 in.) or less
Service Limit:	0.5 mm (0.02 in.)





# Brakes

## Table of Contents

Exploded View .....	12-2	Rear Brake Pad Installation .....	12-14
Specifications .....	12-6	Brake Pad Wear Inspection .....	12-14
Special Tools .....	12-7	Master Cylinder .....	12-15
Brake Lever, Brake Pedal.....	12-8	Front Master Cylinder Removal ...	12-15
Brake Lever Position Adjustment.	12-8	Front Master Cylinder Installation	12-16
Brake Pedal Position Inspection .	12-8	Rear Master Cylinder Removal....	12-16
Brake Pedal Position Adjustment	12-8	Rear Master Cylinder Installation.	12-17
Brake Pedal Removal .....	12-8	Front Master Cylinder	
Brake Pedal Installation .....	12-9	Disassembly.....	12-17
Calipers .....	12-10	Rear Master Cylinder	
Front Caliper Removal .....	12-10	Disassembly.....	12-17
Rear Caliper Removal.....	12-10	Master Cylinder Assembly .....	12-17
Caliper Installation .....	12-10	Master Cylinder Inspection (Visual	
Front Caliper Disassembly.....	12-11	Inspection).....	12-17
Front Caliper Assembly.....	12-11	Brake Disc .....	12-19
Rear Caliper Disassembly .....	12-11	Brake Disc Removal .....	12-19
Rear Caliper Assembly .....	12-11	Brake Disc Installation .....	12-19
Caliper Fluid Seal Damage.....	12-11	Brake Disc Wear .....	12-19
Rear Caliper Dust Boot and		Brake Disc Warp .....	12-19
Friction Boot Damage .....	12-12	Brake Fluid .....	12-20
Caliper Piston and Cylinder		Brake Fluid Level Inspection.....	12-20
Damage.....	12-12	Brake Fluid Change .....	12-20
Rear Caliper Holder Shaft Wear ..	12-12	Brake Line Bleeding.....	12-20
Brake Pads .....	12-13	Brake Hose.....	12-23
Front Brake Pad Removal.....	12-13	Brake Hose Removal/Installation.	12-23
Front Brake Pad Installation.....	12-13	Brake Hose Inspection.....	12-23
Rear Brake Pad Removal .....	12-14		



## Exploded View

No.	Fastener	Torque			Remarks
		N·m	kgf·m	ft·lb	
1	Brake Lever Pivot Bolt	1.0	0.10	8.9 in·lb	Si
2	Front Master Cylinder Clamp Bolts	8.8	0.90	78 in·lb	S
3	Front Brake Light Switch Screw	1.2	0.12	11 in·lb	
4	Front Brake Reservoir Cap Stopper Screw	1.2	0.12	11 in·lb	
5	Brake Lever Pivot Bolt Locknut	6.0	0.61	53 in·lb	
6	Brake Hose Banjo Bolts	25	2.5	18	
7	Front Caliper Mounting Bolts	34	3.5	25	
8	Front Caliper Assembly Bolts	22	2.2	16	
9	Front Brake Pad Pins	15	1.5	11	
10	Front Brake Disc Mounting Bolts	27	2.8	20	L
11	Bleed Valves	7.8	0.80	69 in·lb	

B: Apply brake fluid.

L: Apply a non-permanent locking agent.

R: Replacement Parts

S: Follow the specific tightening sequence.

Si: Apply silicone grease (ex. PBC grease).

# 12-4 BRAKES

## Exploded View

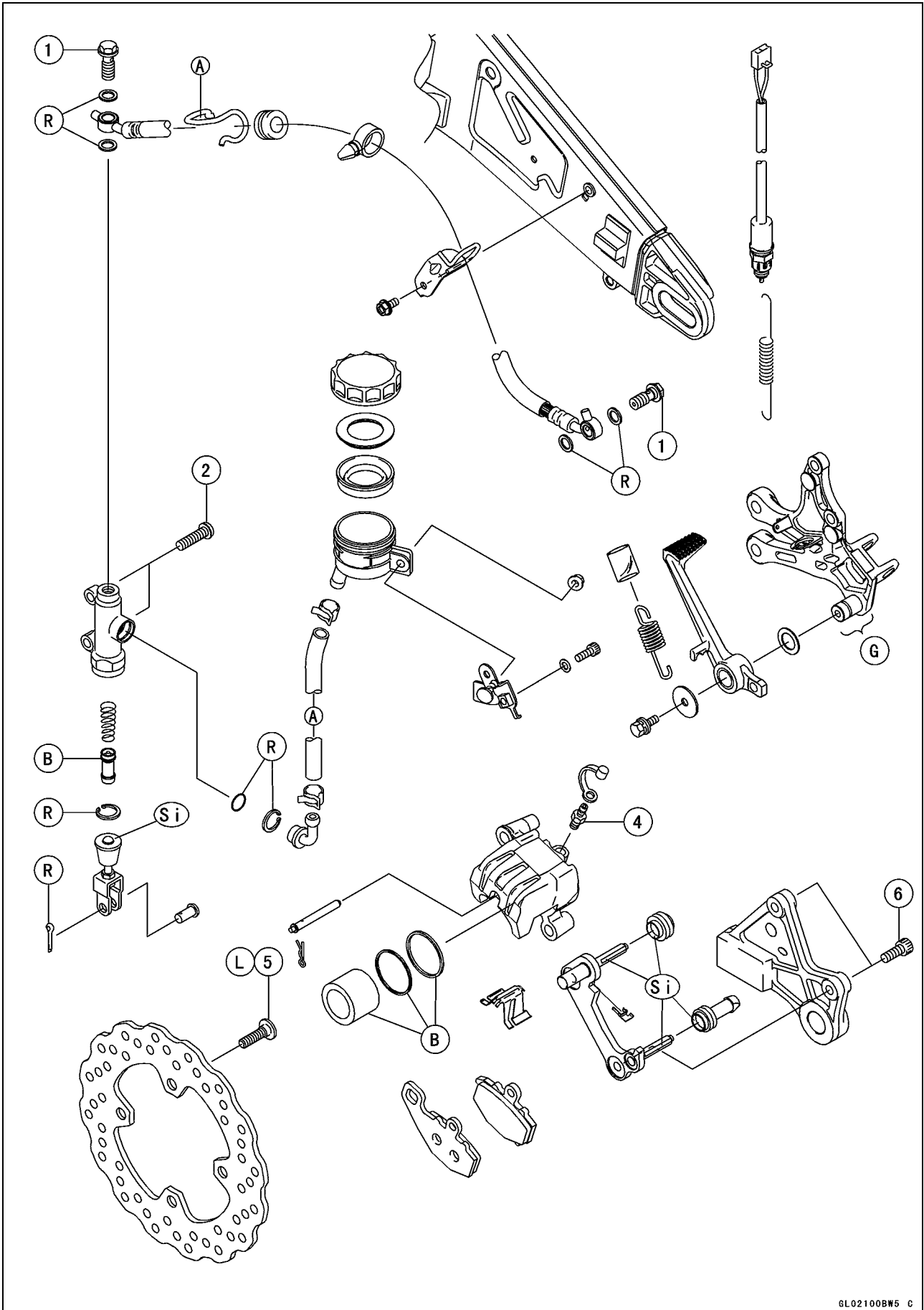

## Exploded View

No.	Fastener	Torque			Remarks
		N·m	kgf·m	ft·lb	
1	Brake Hose Banjo Bolts	25	2.5	18	
2	Rear Master Cylinder Mounting Bolts	25	2.5	18	
3	Rear Master Cylinder Push Rod Locknut	18	1.8	13	
4	Bleed Valve	7.8	0.80	69 in·lb	
5	Rear Brake Disc Mounting Bolts	27	2.8	20	L
6	Rear Caliper Mounting Bolts	25	2.5	18	

B: Apply brake fluid.

G: Apply grease.

L: Apply a non-permanent locking agent.

R: Replacement Parts

Si: Apply silicone grease (ex. PBC grease).

## 12-6 BRAKES

### Specifications

Item	Standard	Service Limit
<b>Brake Lever, Brake Pedal</b>		
Brake Lever Position	5-way adjustable (to suit rider)	— — —
Brake Lever Free Play	Non-adjustable	— — —
Pedal Free Play	Non-adjustable	— — —
Pedal Position	About 45 mm (1.8 in.) below footpeg top	— — —
<b>Brake Discs</b>		
Thickness:		
Front	5.8 ~ 6.2 mm (0.23 ~ 0.24 in.)	5.5 mm (0.22 in.)
Rear	4.8 ~ 5.2 mm (0.19 ~ 0.20 in.)	4.5 mm (0.18 in.)
Runout	0.15 mm (0.006 in.) or less	0.3 mm (0.01 in.)

**Special Tools**

**Inside Circlip Pliers:**  
**57001-143**

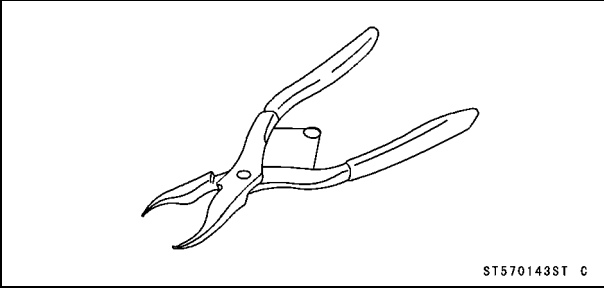

**Jack:**  
**57001-1238**

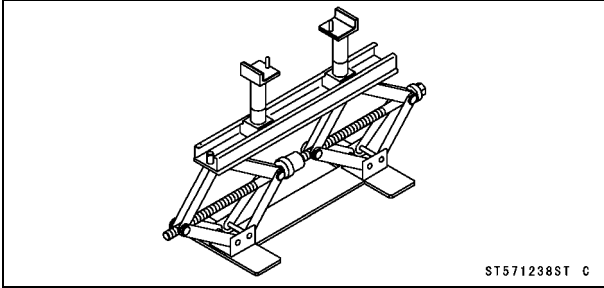

## 12-8 BRAKES

### Brake Lever, Brake Pedal

#### Brake Lever Position Adjustment

The brake lever adjuster has 5 positions so that the brake lever position can be adjusted to suit the operator's hand.

- Push the lever forward and turn the adjuster [A] to align the number with the arrow mark [B] on the lever holder.
- The distance from the grip to the lever is minimum at number 5 and maximum at number 1.

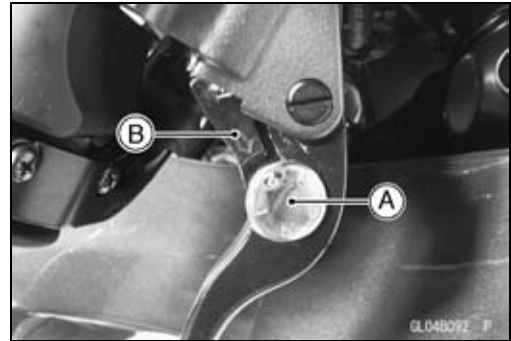

#### Brake Pedal Position Inspection

- Check that the brake pedal [A] is in the correct position. [B] Footpeg

##### Pedal Position

**Standard:** About 45 mm (1.8 in.) [C] below top of footpeg

- ★ If it is incorrect, adjust the brake pedal position.

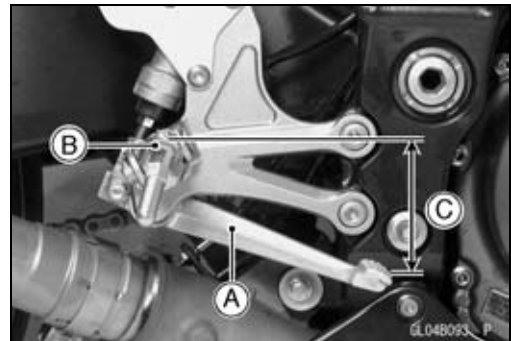

#### Brake Pedal Position Adjustment

##### NOTE

○ Usually it is not necessary to adjust the pedal position, but always adjust it when push rod locknut has been loosened.

- Remove the right foot guard [A], and then tighten the master cylinder bolts [B] only.

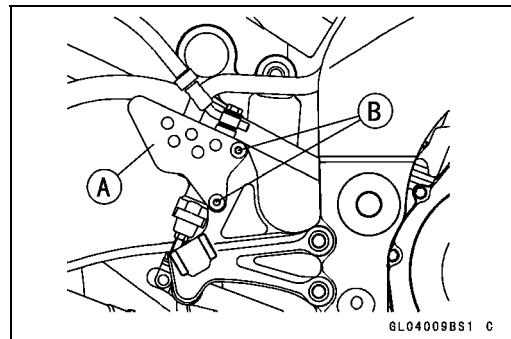

- Loosen the locknut [A] and turn the push rod with the hex head [B] to achieve the correct pedal position.
- ★ If the length [C] shown is  $80 \pm 1$  mm ( $2.6 \pm 0.04$  in.), the pedal position will be within the standard range.
- Tighten:

**Torque - Rear Master Cylinder Push Rod Locknut: 18 N·m (1.8 kgf·m, 13 ft·lb)**

- Check the brake light switch operation (see Periodic Maintenance chapter).

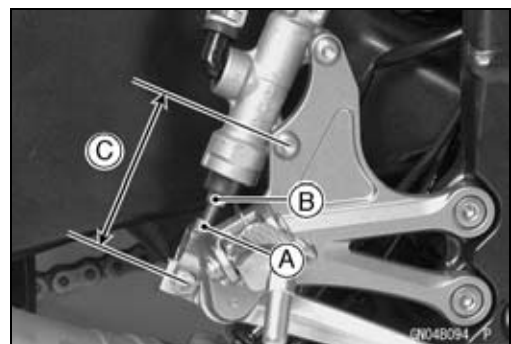

#### Brake Pedal Removal

- Remove:
  - Right Foot Guard Bolts [A]
  - Right Foot Stay Bolts [B]

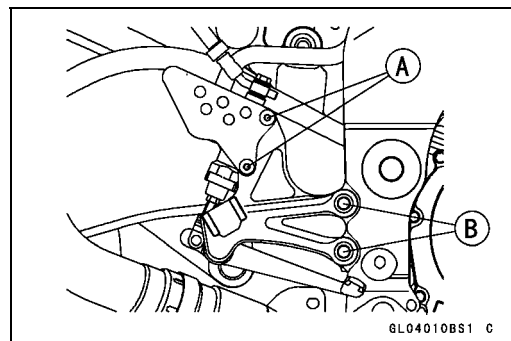



## Brake Lever, Brake Pedal

- Remove:
  - Cotter Pin [A]
  - Joint Pin [B]
  - Rear Brake Light Switch Spring [C]
  - Return Sprig [D]
- Remove the mounting bolt [E] and take out the brake pedal [F].

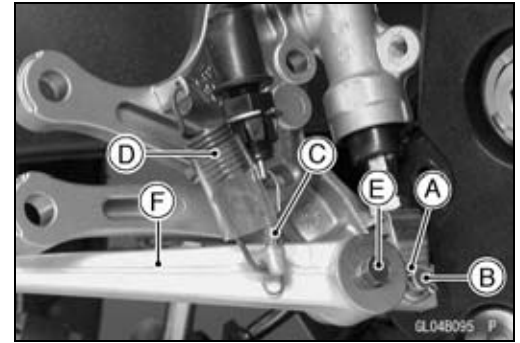

### Brake Pedal Installation

- Apply high-temperature grease to the pivot shaft [A] and install the washer [B].
- Install:
  - Brake Pedal [C]
  - Washer [D]
  - Brake Pedal Bolt [E]

**Torque - Brake Pedal Bolt: 8.8 N·m (0.90 kgf·m, 78 in·lb)**

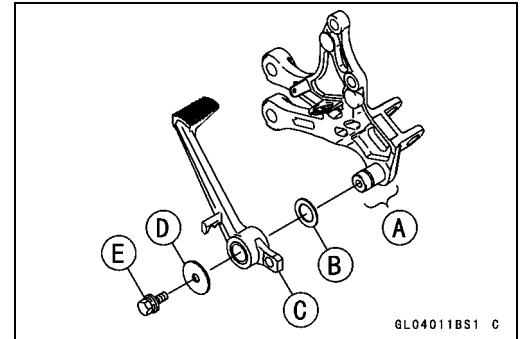

- Hook the lower end of the rear brake light switch spring [A] on the pedal hook.
- Hook the upper end of the return spring [B] on the pedal hook.

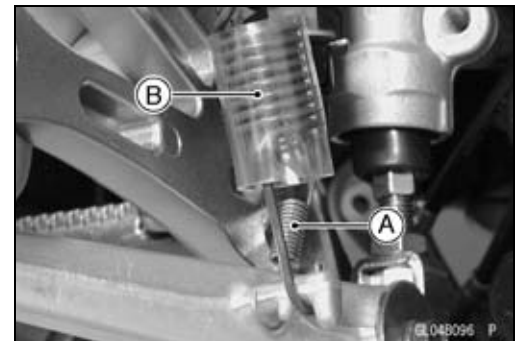

- Replace the cotter pin with a new one.
- Insert the cotter pin [A] and bend the pin ends [B].

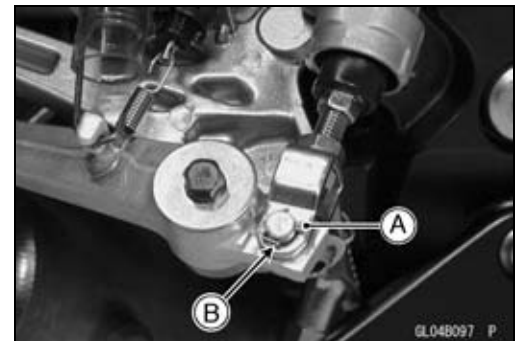

- Install the right footpeg stay.
  - Torque - Front Footpeg Stay Bolts: 25 N·m (2.5 kgf·m, 18 ft·lb)**
- Install the rear master cylinder.
  - Depress the brake pedal [A] and then align the bolts holes of the master cylinder [B].
  - Torque - Foot Guard Bolts: 25 N·m (2.5 kgf·m, 18 ft·lb)**
- Check the brake pedal position (see Periodic Maintenance chapter).

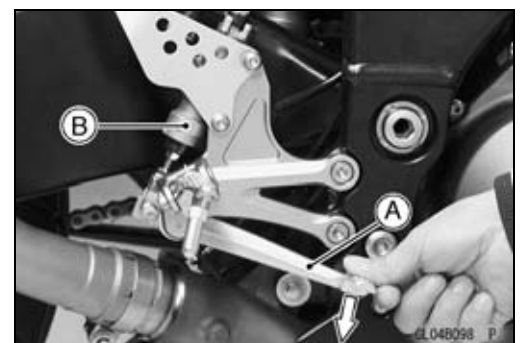

## 12-10 BRAKES

### Calipers

#### Front Caliper Removal

- Loosen the banjo bolt [A] at the brake hose lower end, and tighten it loosely.
- Unscrew the caliper mounting bolts [B], and detach the caliper [C] from the disc.

#### CAUTION

**Do not loosen the caliper assembly bolts [D]. Take out only the caliper mounting bolts for caliper removal. Loosening the caliper assembly bolts will cause brake fluid leakage.**

- Unscrew the banjo bolt and remove the brake hose [E] from the caliper (see Brake Hose Removal/Installation).

#### CAUTION

**Immediately wash away any brake fluid that spills.**

#### NOTE

○If the caliper is to be disassembled after removal and if compressed air is not available, disassemble the caliper before the brake hose is removed (see Front Caliper Disassembly).

#### Rear Caliper Removal

- Loosen the banjo bolt [A] at the brake hose lower end, and tighten it loosely.
- Unscrew the caliper mounting bolts [B], and detach the caliper [C] from the disc.
- Unscrew the banjo bolt and remove the brake hose [D] from the caliper.

#### CAUTION

**Immediately wash away any brake fluid that spills.**

#### NOTE

○If the caliper is to be disassembled after removal and if compressed air is not available, disassemble the caliper before the brake hose is removed (see Rear Caliper Disassembly).

#### Caliper Installation

- Install the caliper and brake hose lower end.
- Replace the washers on each side of hose fitting with new ones.
- Tighten:

**Torque - Caliper Mounting Bolts (Front): 34 N·m (3.5 kgf·m, 25 ft·lb)**

**Caliper Mounting Bolts (Rear): 25 N·m (2.5 kgf·m, 18 ft·lb)**

**Brake Hose Banjo Bolt: 25 N·m (2.5 kgf·m, 18 ft·lb)**

- Check the fluid level in the brake reservoirs.
- Bleed the brake line (see Brakes Line Bleeding).
- Check the brake for good braking power, no brake drag, and no fluid leakage.

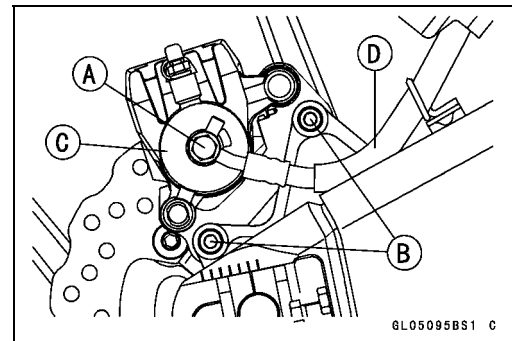
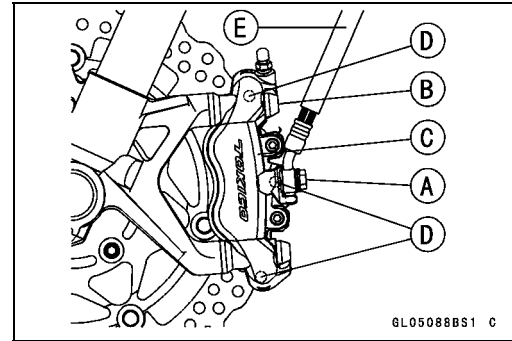

## Calipers

### **⚠ WARNING**

Do not attempt to drive the motorcycle until a full brake lever or pedal is obtained by pumping the brake lever or pedal until the pads are against the disc. The brakes will not function on the first application of the lever or pedal if this is not done.

#### *Front Caliper Disassembly*

- Refer to Caliper Rubber Parts Replacement in the Periodic Maintenance chapter.

#### *Front Caliper Assembly*

- Refer to Caliper Rubber Parts Replacement in the Periodic Maintenance chapter.

#### *Rear Caliper Disassembly*

- Refer to Caliper Rubber Parts Replacement in the Periodic Maintenance chapter.

#### *Rear Caliper Assembly*

- Refer to Caliper Rubber Parts Replacement in the Periodic Maintenance chapter.

#### *Caliper Fluid Seal Damage*

The fluid seal (piston seal) [A] is placed around the piston to maintain clearance between the pad and the disc. If the seal is in a poor condition, it could lead the pad to wear excessively or the brake to drag, which may cause the temperature of the discs or the brake fluid to increase.

- Replace the fluid seal if it exhibits any of the conditions listed below.
  - Brake fluid leakage around the pad.
  - Brakes overheat.
  - Considerable difference in inner and outer pad wear.
  - Seal and piston are stuck together.
- ★ If the fluid seal is replaced, replace the dust seal [B] as well. Also, replace all seals every other time the pads are changed.

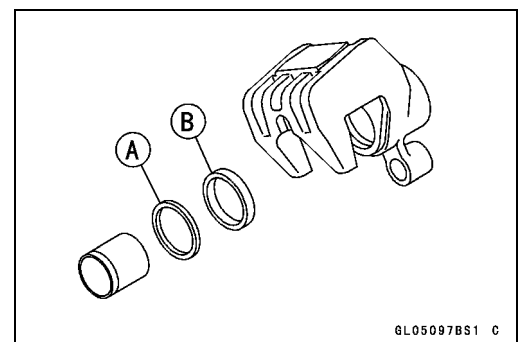
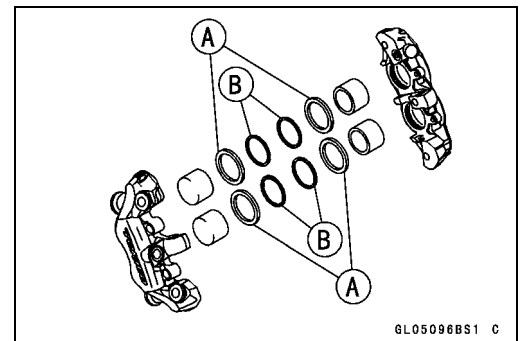

## 12-12 BRAKES

### Calipers

#### Rear Caliper Dust Boot and Friction Boot Damage

- Check that the dust boot [A] and friction boot [B] are not cracked, worn, swollen, or otherwise damaged.
- ★ If they show any damage, replace it.

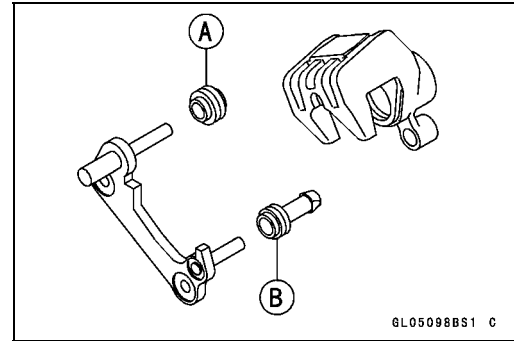

#### Caliper Piston and Cylinder Damage

- Visually inspect the pistons [A] and cylinder surfaces [B].
- ★ Replace the caliper if the cylinder and piston are badly scored or rusty.

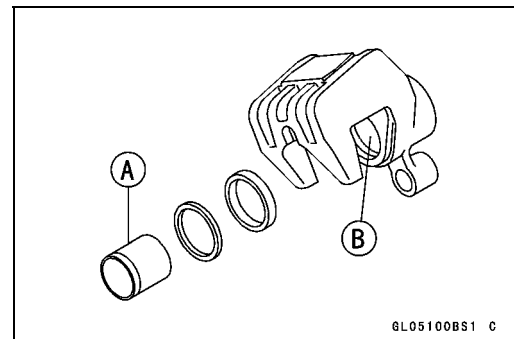
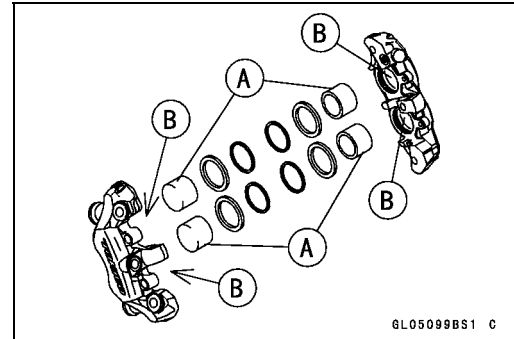

#### Rear Caliper Holder Shaft Wear

The caliper body must slide smoothly on the caliper holder shafts [A]. If the body does not slide smoothly, one pad will wear more than the other, pad wear will increase, and constant drag on the disc will raise brake and brake fluid temperature.

- Check to see that the caliper holder shafts are not badly worn or stepped, and that the rubber friction boots are not damaged.
- ★ If the rubber friction boot is damaged, replace the rubber friction boot. To replace the friction boot, remove the pads and the caliper bracket.
- ★ If the caliper holder shaft is damaged, replace the caliper bracket.

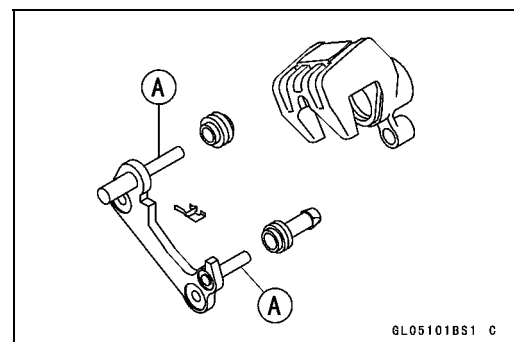

## Brake Pads

### Front Brake Pad Removal

- Remove:
  - Caliper Mounting Bolts [A]
- Loosen:
  - Pad Pins [B]

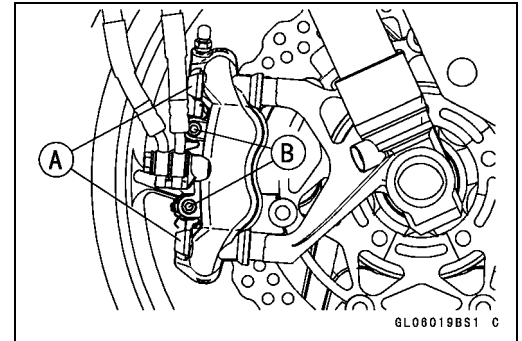

- Remove:
  - Pad Pins [A]
  - Pad Spring [B]
  - Brake Pads [C]

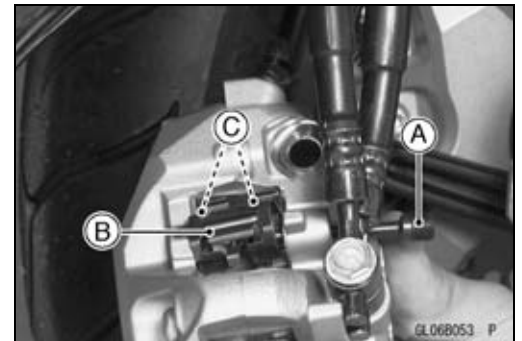

### Front Brake Pad Installation

- Push the caliper pistons in by hand as far as they will go.
- Install the outside pad [A] and insert the pin [B] as shown.

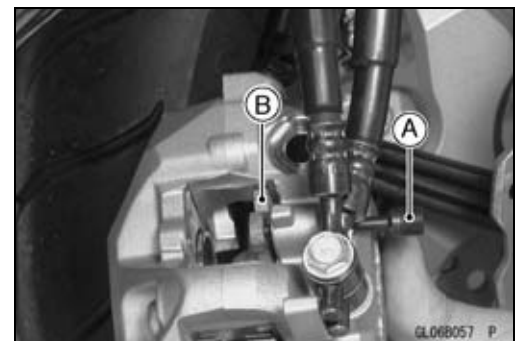

- Set:
  - Inside Pad [A]
  - Pad Spring [B]
- Pushing the pin holder [C] to hole of the pad and insert the pin.

**Torque - Front Brake Pad Pins: 15 N·m (1.5 kgf·m, 11 ft·lb)**

### **⚠ WARNING**

**Do not attempt to drive the motorcycle until a full brake lever is obtained by pumping the brake lever and the pads are against the disc. The brake will not function on the first application of the lever if this is not done.**

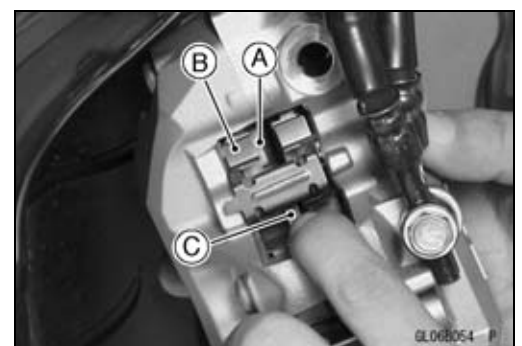

## 12-14 BRAKES

### Brake Pads

#### *Rear Brake Pad Removal*

- Remove the caliper with the hose installed.
- Remove:
  - Clip [A]
  - Pad Pin [B]
  - Brake Pads [C]

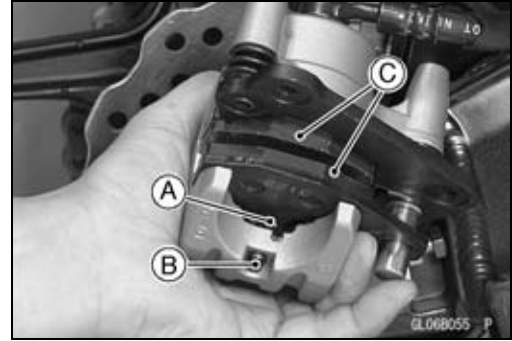

#### *Rear Brake Pad Installation*

- Push the caliper piston in by hand as far as it will go.
- Install the anti-rattle spring in place.
- Install the piston side pad [A] first, and then another pad.
- Fit the projections [B] of the pad into the recess [C] of the caliper holder.
- Install the pad pin and clip. The clip must be "outside" of the pads.
- Install the caliper (see Caliper Installation).

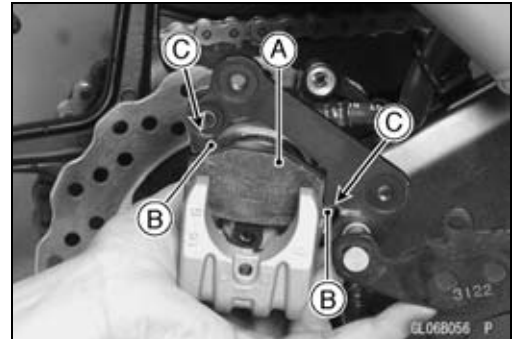

### **⚠ WARNING**

**Do not attempt to drive the motorcycle until a full brake pedal is obtained by pumping the brake pedal until the pads are against the disc. The brake will not function on the first application of the pedal if this is not done.**

#### *Brake Pad Wear Inspection*

- Refer to the Brake Pad Wear Inspection in the Periodic Maintenance chapter.

## Master Cylinder

### Front Master Cylinder Removal

- Remove the reservoir bracket bolts [A].



- Remove the banjo bolt [A] to disconnect the brake hose from the master cylinder (see Brake Hose Removal/Installation).
- Unscrew the clamp bolts [B], and take off the master cylinder [C] as an assembly with the reservoir, brake lever, and brake switch installed.

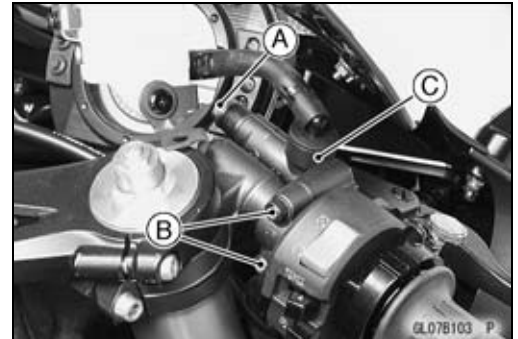

### CAUTION

Immediately wash away any brake fluid that spills.

- Disconnect the front brake light switch connector [A].
- Remove:  
Front Brake Light Switch [B]

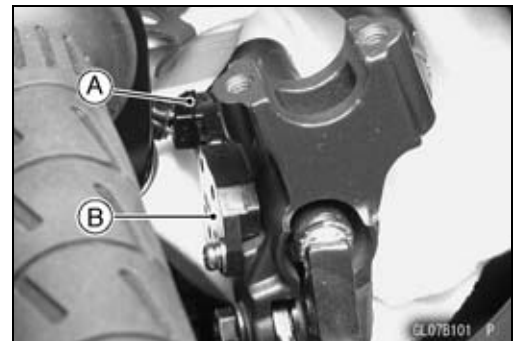

- Remove:  
Brake Lever Pivot Bolt and Nut [A]  
Brake Lever [B]  
Clamp [C] (slide out)  
Brake Hose [D]

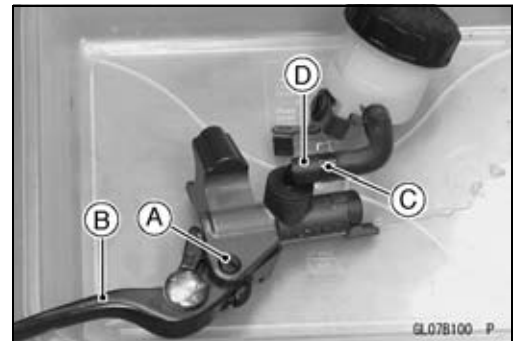

## 12-16 BRAKES

### Master Cylinder

#### Front Master Cylinder Installation

- Set the front master cylinder to match its mating surface [A] to the punch mark [B] of the handlebar.
- The master cylinder clamp must be installed with the arrow mark [C] upward.
- Tighten the upper clamp bolt first, and then the lower clamp bolt.

**Torque - Front Master Cylinder Clamp Bolts: 8.8 N·m (0.90 kgf·m, 78 in·lb)**

- Replace the washers that are on each side of the hose fitting with new ones.
- Tighten:

**Torque - Brake Hose Banjo Bolt: 25 N·m (2.5 kgf·m, 18 ft·lb)**

- Bleed the brake line (see Brake Line Bleeding).
- Check the brake for good braking power, no brake drag, and no fluid leakage.

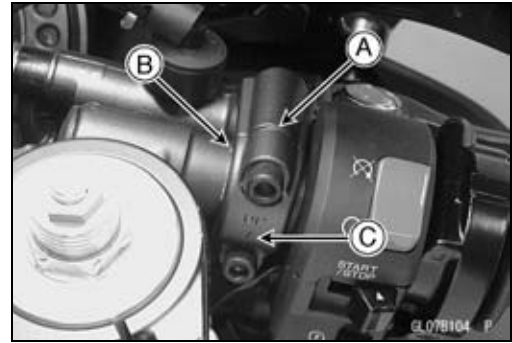

#### **⚠ WARNING**

**Do not attempt to drive the motorcycle until a full brake pedal is obtained by pumping the brake pedal until the pads are against the disc. The brake will not function on the first application of the pedal if this is not done.**

#### Rear Master Cylinder Removal

- Unscrew the brake hose banjo bolt [A] and brake hose [B]
- Slide out the clamp [C].
- Pull off the reservoir hose lower end [D], and drain the brake fluid into a container.
- Remove:
  - Bolts [E]
  - Foot Guard [F]
  - Front Footpeg Stay Bolts [G]
- Remove:
  - Cotter Pin [A]
  - Join Pin [B]
  - Rear Master Cylinder

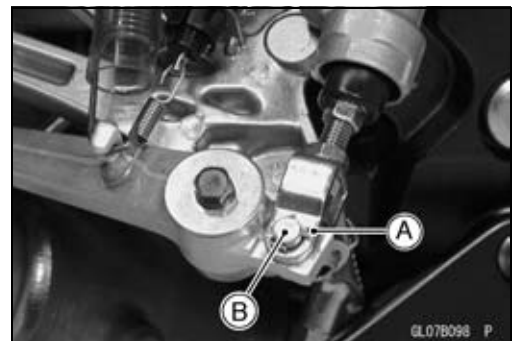
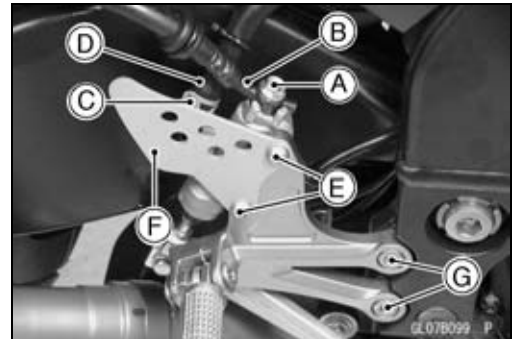



## Master Cylinder

### Rear Master Cylinder Installation

- Replace the cotter pin with a new one.
- Replace the washers that are on each side of hose fitting with new ones.
- Tighten:

**Torque - Front Footpeg Stay Bolts: 25 N·m (2.5 kgf·m, 18 ft·lb)**

**Foot Guard Bolts: 25 N·m (2.5 kgf·m, 18 ft·lb)**

**Brake Hose Banjo Bolt: 25 N·m (2.5 kgf·m, 18 ft·lb)**

- Bleed the brake line (see Brake Line Bleeding).
- Check the brake for good braking power, no brake drag, and no fluid leakage.

### ⚠ WARNING

**Do not attempt to drive the motorcycle until a full brake pedal is obtained by pumping the brake pedal until the pads are against the disc. The brake will not function on the first application of the pedal if this is not done.**

### Front Master Cylinder Disassembly

- Refer to Master Cylinder Rubber Parts Replacement in the Periodic Maintenance chapter.

### Rear Master Cylinder Disassembly

- Refer to Master Cylinder Rubber Parts Replacement in the Periodic Maintenance chapter.

### Master Cylinder Assembly

- Refer to Master Cylinder Rubber Parts Replacement in the Periodic Maintenance chapter.

### Master Cylinder Inspection (Visual Inspection)

- Remove the master cylinders (see Front and Rear Master Cylinder Removal).
  - Disassemble the front and rear master cylinders (see Periodic Maintenance chapter).
  - Check that there are no scratches, rust or pitting on the inner wall [A] of each master cylinder and on the outside of each piston [B].
  - ★ If a master cylinder or piston shows any damage, replace them.
  - Inspect the primary cup [C] and secondary cup [D].
  - ★ If a cup is worn, damaged softened (rotted), or swollen, the piston assembly should be replaced to renew the cups.
  - ★ If fluid leakage is noted at the brake lever, the piston assembly should be replaced to renew the cups.
- Front Master Cylinder [J]

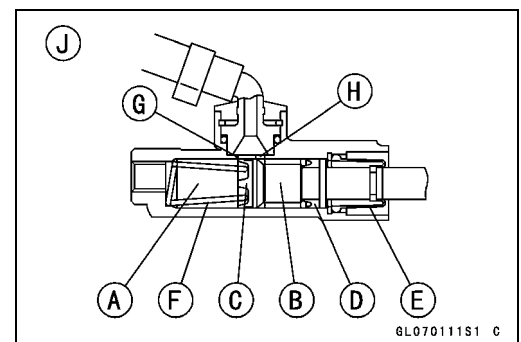

## 12-18 BRAKES

### Master Cylinder

- Check the dust covers [E] for damage.
- ★ If they are damaged, replace them.
- Check the piston return spring [F] for any damage.
- ★ If the springs are damaged, replace them.
- Check that relief port [G] and supply port [H] are not plugged.
- ★ If the relief port becomes plugged, the brake pads will drag on the disc. Blow the ports clean with compressed air.

Rear Master Cylinder [K]

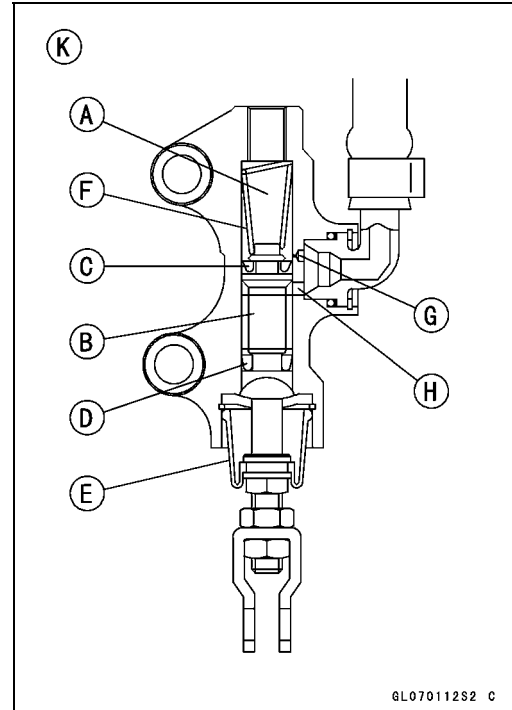

## Brake Disc

### Brake Disc Removal

- Remove the wheel (see Wheels/Tires chapter).
- Unscrew the mounting bolts, and take off the disc.

### Brake Disc Installation

- Install the brake disc on the wheel so that the marked side [B] faces out.
- Apply a non-permanent locking agent to the threads of the rear brake disc mounting bolts [A].
- Tighten:

**Torque - Brake Disc Mounting Bolts: 27 N·m (2.8 kgf·m, 20 ft·lb)**

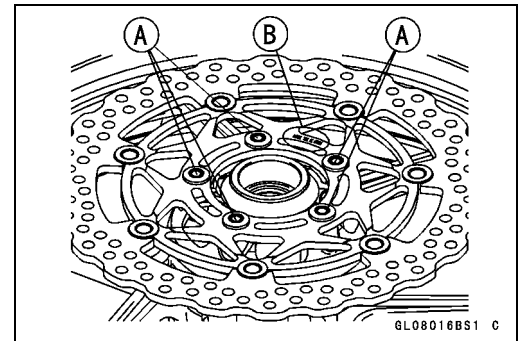

### Brake Disc Wear

- Measure the thickness of each disc [A] at the point where it has worn the most.
  - ★ If the disc has worn past the service limit, replace it.
- [B] Measuring Area

#### Front Brake Discs Thickness

**Standard:** 5.8 ~ 6.2 mm (0.23 ~ 0.24 in.)

**Service Limit:** 5.5 mm (0.22 in.)

#### Rear Brake Discs Thickness

**Standard:** 4.8 ~ 5.2 mm (0.19 ~ 0.20 in.)

**Service Limit:** 4.5 mm (0.18 in.)

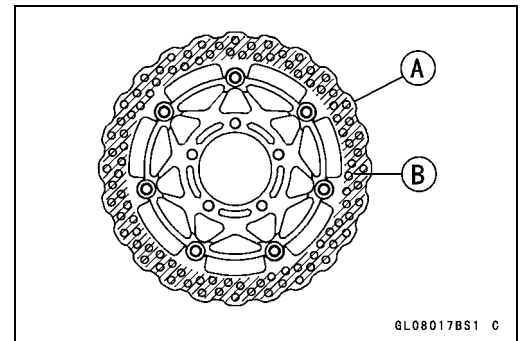

### Brake Disc Warp

- Jack up the motorcycle so that the wheel is off the ground (see Wheels/Tires chapter).

**Special Tool - Jack: 57001-1238**

- For front disc inspection, turn the handlebar fully to one side.
- Set up a dial gauge against the disc [A] as shown and measure disc runout, while turning [B] the wheel by hand.
- ★ If runout exceeds the service limit, replace the disc.

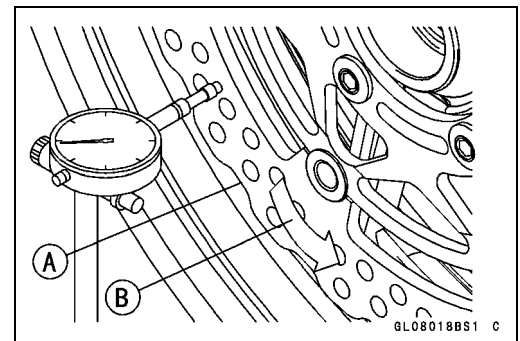

#### Disc Runout

**Standard:** 0.15 mm (0.006 in.) or less

**Service Limit:** 0.3 mm (0.01 in.)

## 12-20 BRAKES

### Brake Fluid

#### *Brake Fluid Level Inspection*

- Refer to the Brake Fluid Level Inspection in the Periodic Maintenance chapter.

#### *Brake Fluid Change*

- Refer to the Brake Fluid Change in the Periodic Maintenance chapter.

#### *Brake Line Bleeding*

The brake fluid has a very low compression coefficient so that almost all the movement of the brake lever or pedal is transmitted directly to the caliper for braking action. Air, however, is easily compressed. When air enters the brake lines, brake lever or pedal movement will be partially used in compressing the air. This will make the lever or pedal feel spongy, and there will be a loss in braking power.

### **⚠ WARNING**

**Be sure to bleed the air from the brake line whenever brake lever or pedal action feels soft or spongy after the brake fluid is changed, or whenever a brake line fitting has been loosened for any reason.**

### **NOTE**

○ *The procedure to bleed the front brake line is as follows. Bleeding the rear brake line is the same as for the front brake.*

- Remove:
  - Screw [A]
  - Clamp [B]
  - Reservoir [C]
  - Diaphragm Plate
  - Diaphragm
- Fill the reservoir with fresh brake fluid to the upper level line in the reservoir.
- With the reservoir cap off, slowly pump the brake lever several times until no air bubbles can be seen rising up through the fluid from the holes at the bottom of the reservoir.
- Bleed the air completely from the master cylinder by this operation.
- Remove the rubber cap [A] from the bleed valve on the caliper.
- Attach a clear plastic hose [B] to the bleed valve, and run the other end of the hose into a container.

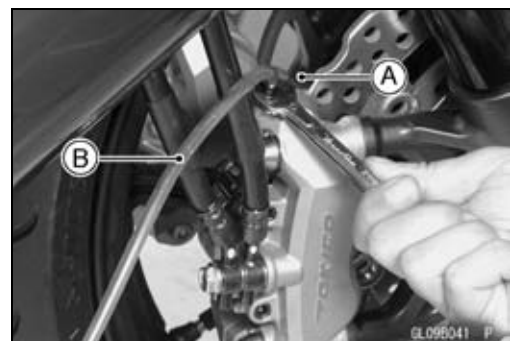
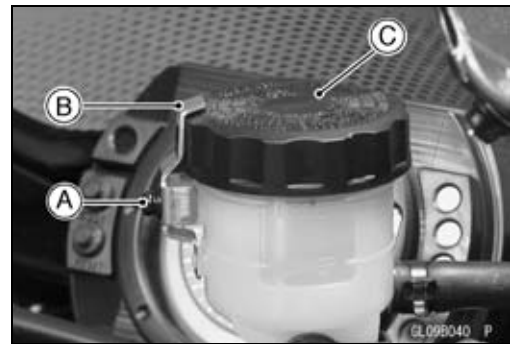

## Brake Fluid

- Bleed the brake line and the caliper:
  - Repeat this operation until no more air can be seen coming out into the plastic hose.

  1. Pump the brake lever until it becomes hard, and apply the brake and hold it [A].
  2. Quickly open and close [B] the bleed valve while holding the brake applied.
  3. Release the brake [C].

### NOTE

- The fluid level must be checked often during the bleeding operation and replenished with fresh brake fluid as necessary. If the fluid in the reservoir runs completely out any time during bleeding, the bleeding operation must be done over again from the beginning since air will have entered the line.
  - Tap the brake hose lightly from the caliper to the reservoir for more complete bleeding.
  - Front Brake: First bleeding the right caliper then repeat the above steps for the left caliper.
- Remove the clear plastic hose.

- Install:
  - Diaphragm [A]
  - Diaphragm Plate [B]
  - Front Brake Reservoir Cap [C]
  - Clamp [D]
  - Screw [E]
- Tighten:

- Follow the procedure below to install the brake fluid reservoir cap correctly.
  - First, tighten the brake fluid reservoir cap [B] clockwise [C] by hand until the resistance is felt fully; then, tighten the cap an additional 1/6 turn [D] while holding the brake fluid reservoir [A] body.

- Tighten the bleed valve, and install the rubber cap.
  - Torque - Bleed Valve: 7.8 N·m (0.80 kgf·m, 69 in·lb)**
- Check the fluid level (see Periodic Maintenance chapter).
- After bleeding is done, check the brake for good braking power, no brake drag, and no fluid leakage.

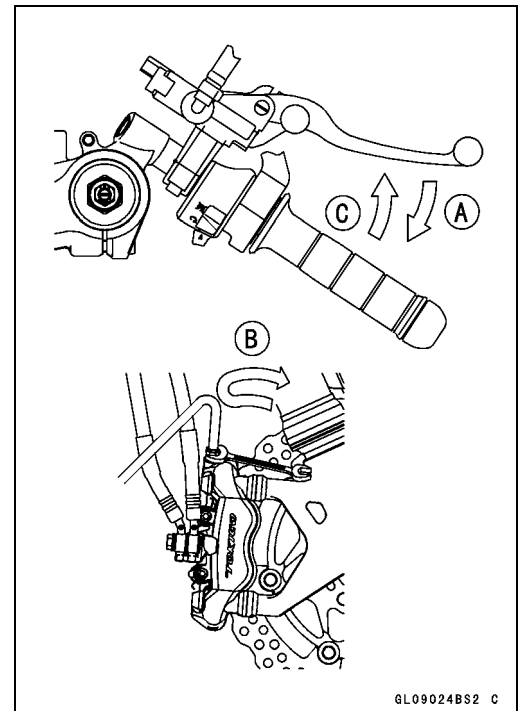

GL09024BS2 C

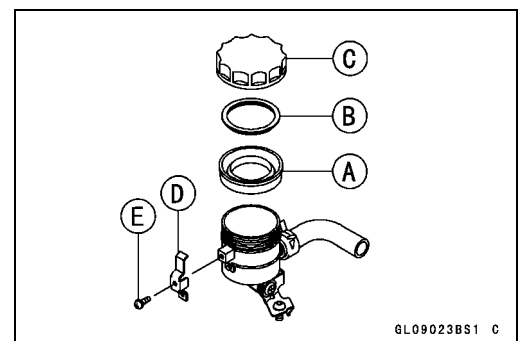

GL09023BS1 C

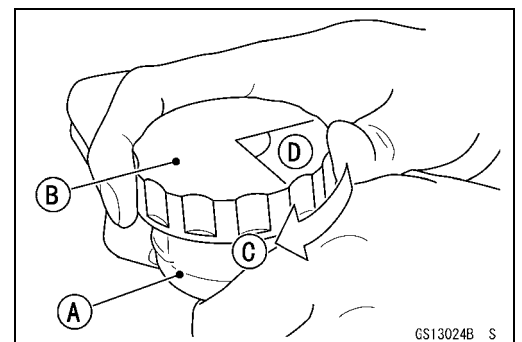

GS13024B S

## 12-22 BRAKES

### Brake Fluid

#### **WARNING**

**When working with the disc brake, observe the precautions listed below.**

1. Never reuse old brake fluid.
2. Do not use fluid from a container that has been left unsealed or that has been open for a long time.
3. Do not mix two types and brands of fluid for use in the brake. This lowers the brake fluid boiling point and could cause the brake to be ineffective. It may also cause the rubber brake parts to deteriorate.
4. Don't leave the reservoir cap off for any length of time to avoid moisture contamination of the fluid.
5. Don't change the fluid in the rain or when a strong wind is blowing.
6. Except for the disc pads and disc, use only disc brake fluid, isopropyl alcohol, or ethyl alcohol for cleaning of the brake parts. Do not use any other fluid for cleaning these parts. Gasoline, engine oil, or any other petroleum distillate will cause deterioration of the rubber parts. Oil spilled on any part will be difficult to wash off completely and will eventually deteriorate the rubber used in the disc brake.
7. When handling the disc pads or disc, be careful that no disc brake fluid or any oil gets on them. Clean off any fluid or oil that inadvertently gets on the pads or disc with a high-flash point solvent. Do not use one which will leave an oily residue. Replace the pads with new ones if they cannot be cleaned satisfactorily.
8. Brake fluid quickly ruins painted surfaces; any spilled fluid should be completely wiped up immediately.
9. If any of the brake line fittings or the bleed valve is opened at any time, the **AIR MUST BE BLED FROM THE BRAKE LINE.**

**Brake Hose**

---

*Brake Hose Removal/Installation*

- Refer to the Brake Hose and Pipe Replacement in the Periodic Maintenance chapter.

*Brake Hose Inspection*

- Refer to the Brake Hose Damage and Installation Connection Inspection in the Periodic Maintenance chapter.





# Suspension

## Table of Contents

Exploded View .....	13-2
Specifications .....	13-6
Special Tools .....	13-7
Front Fork .....	13-9
Rebound Damping Force Adjustment .....	13-9
Compression Damping Force Adjustment .....	13-9
Spring Preload Adjustment .....	13-10
Front Fork Removal (each fork leg) .....	13-10
Front Fork Installation .....	13-11
Front Fork Oil Change .....	13-11
Front Fork Disassembly .....	13-16
Front Fork Assembly .....	13-17
Inner Tube Inspection .....	13-18
Dust Seal Inspection .....	13-18
Spring Tension .....	13-19
Rear Shock Absorber .....	13-20
Rebound Damping Force Adjustment .....	13-20
Compression Damping Force Adjustment .....	13-20
Spring Preload Adjustment .....	13-20
Rear Shock Absorber Removal .....	13-21
Rear Shock Absorber Installation .....	13-22
Rear Shock Absorber Inspection .....	13-22
Rear Shock Absorber Scrapping .....	13-22
Swingarm .....	13-23
Swingarm Removal .....	13-23
Swingarm Installation .....	13-24
Swingarm Bearing Removal .....	13-25
Swingarm Bearing Installation .....	13-25
Swingarm Bearing, Sleeve Inspection .....	13-26
Swingarm Pivot Lubrication .....	13-26
Chain Guide Inspection .....	13-26
Tie-rod, Rocker Arm .....	13-27
Tie-rod Removal .....	13-27
Tie-rod Installation .....	13-27
Rocker Arm Removal .....	13-27
Rocker Arm Installation .....	13-27
Tie-rod and Rocker Arm Bearing Removal .....	13-28
Tie-rod and Rocker Arm Bearing Installation .....	13-28
Rocker Arm/Tie-rod Bearing, Sleeve Inspection .....	13-29
Rocker Arm/Tie-rod Bearing Lubrication .....	13-29

# 13-2 SUSPENSION

## Exploded View

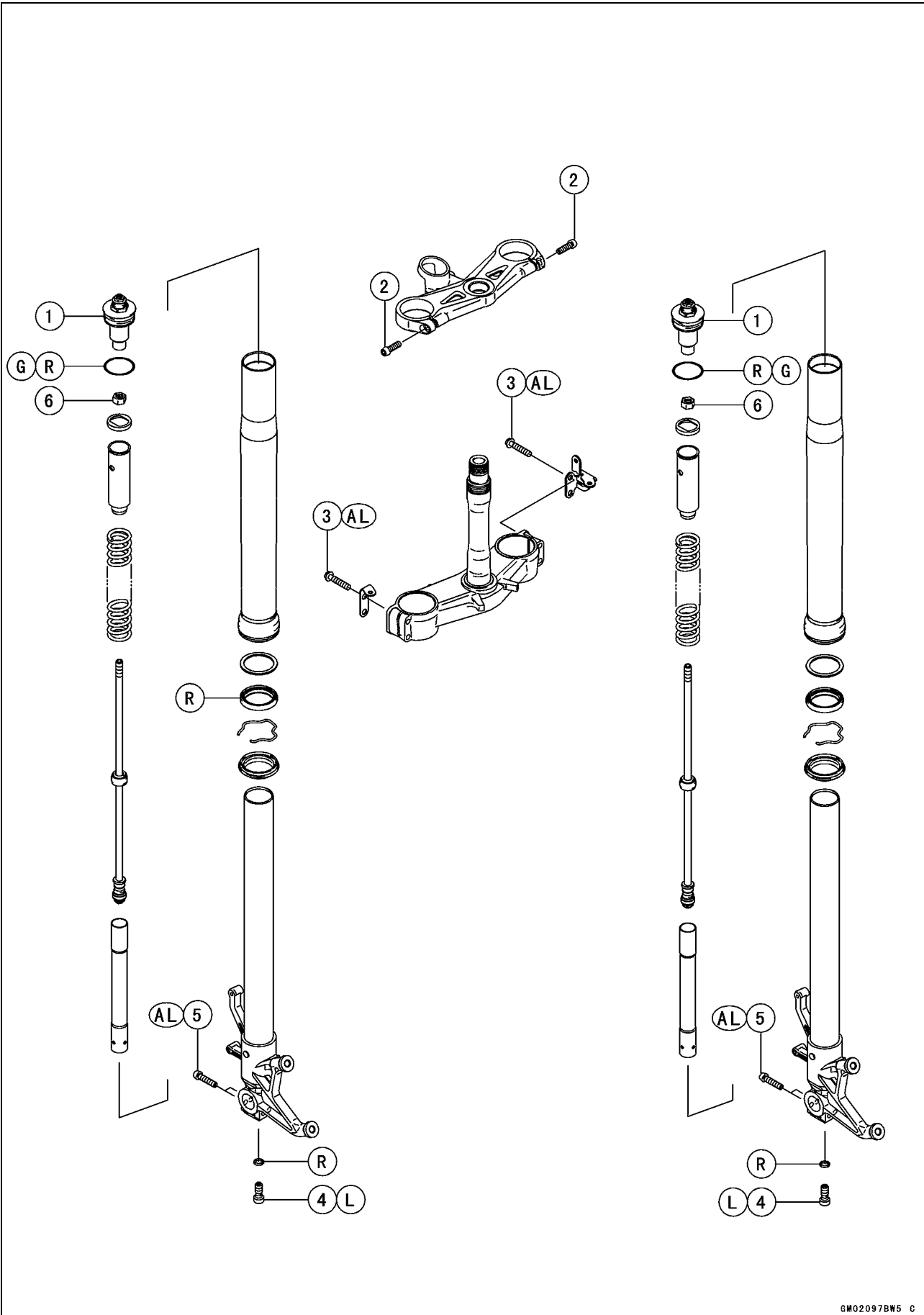

**Exploded View**

No.	Fastener	Torque			Remarks
		N·m	kgf·m	ft·lb	
1	Front Fork Top Plug	23	2.3	17	
2	Front Fork Clamp Bolts (Upper)	20	2.0	14.5	
3	Front Fork Clamp Bolts (Lower)	30	3.0	22	AL
4	Front Fork Bottom Allen Bolts	23	2.3	17	L
5	Front Axle Clamp Bolts	20	2.0	14.5	AL
6	Piston Rod Nut	15	1.5	11	

AL: Tighten the two clamp bolts alternately two times to ensure even tightening torque.

G: Apply grease.

L: Apply a non-permanent locking agent.

R: Replacement Parts

# 13-4 SUSPENSION

## Exploded View

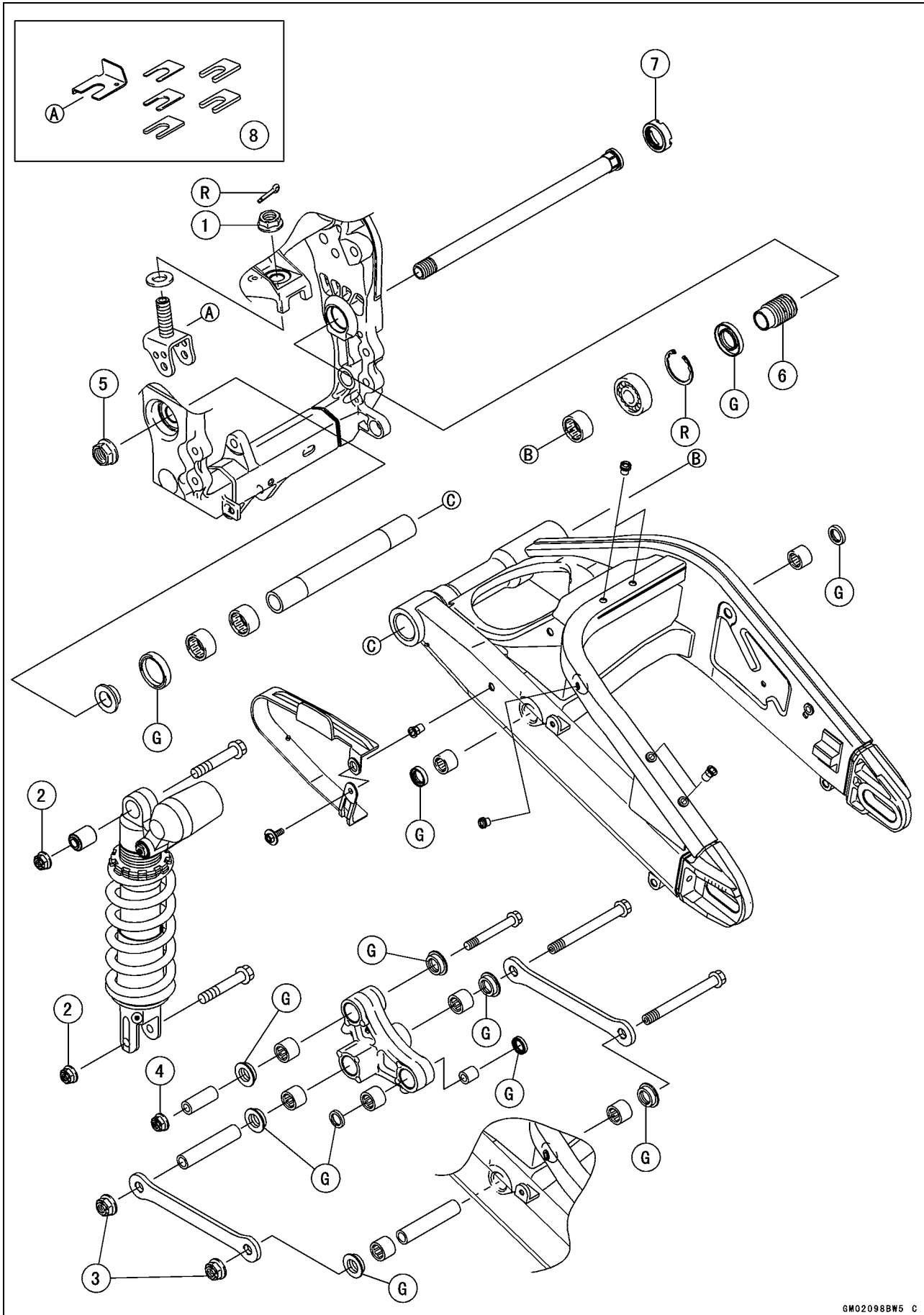

**Exploded View**

No.	Fastener	Torque			Remarks
		N·m	kgf·m	ft·lb	
1	Rear Shock Absorber Bracket Nut	59	6.0	43	
2	Rear Shock Absorber Nuts (Upper and Lower)	34	3.5	25	
3	Tie-rod Nuts	59	6.0	43	
4	Uni-Track Rocker Arm Nut	34	3.5	25	
5	Swingarm Pivot Shaft Nut	108	11	81	
6	Swingarm Pivot Adjusting Collar	20	2.0	14	
7	Swingarm Pivot Adjusting Collar Locknut	98	10	72	

8. Spacer Set (Option)

G: Apply or add grease.

R: Replacement Parts

## 13-6 SUSPENSION

### Specifications

Item	Standard
<p><b>Front Fork (Per One Unit)</b></p> <p>Fork Inner Tube Diameter</p> <p>Air Pressure</p> <p>Rebound Damper Setting</p> <p>Compression Damper Setting</p> <p>Fork Spring Preload Setting</p> <p>Fork Oil:</p> <p>    Viscosity</p> <p>    Amount:</p> <p>        When Changing Oil</p> <p>        After Disassembly and Completely Dry</p> <p>Fork Oil Level: (Fully Compressed, without Spring, below from the Top of the Inner Tube)</p> <p>Fork Spring Free Length</p>	<p><math>\phi 43</math> mm (1.7 in.)</p> <p>Atmospheric pressure (non-adjustable)</p> <p>9th click from the first click of the fully clockwise position (Usable range: 0 <math>\longleftrightarrow</math> 11 clicks)</p> <p>7th click from the first click of the fully clockwise position (Usable range: 0 <math>\longleftrightarrow</math> 13 clicks)</p> <p>Adjuster protrusion is 14 mm (0.55 in.) (Usable range: 4 ~ 19 mm) (0.16 ~ 0.75 in.)</p> <p>KHL15-10 (KAYABA) or equivalent</p> <p>Approx. 490 mL (16.6 US oz.) (ZX1000-C1) Approx. 480 mL (16.2 US oz.) (ZX1000-C2)</p> <p>576 <math>\pm</math>4 mL (19.5 <math>\pm</math>0.14 US oz.) (ZX1000-C1) 565 <math>\pm</math>4 mL (19.1 <math>\pm</math>0.14 US oz.) (ZX1000-C2)</p> <p>91 <math>\pm</math>2 mm (3.58 <math>\pm</math>0.08 in.) (ZX1000-C1) 101 <math>\pm</math>2 mm (3.98 <math>\pm</math>0.08 in.) (ZX1000-C2)</p> <p>245.3 mm (9.66 in.) (Service limit: 243 mm (9.58 in.))</p>
<p><b>Rear Shock Absorber</b></p> <p>Rebound Damper Set</p> <p>Compression Damper Set</p> <p>Spring Preload Setting Position</p> <p>    Standard</p> <p>    Usable Range</p> <p>Gas Pressure</p>	<p>1 3/4 turns out from the fully clockwise position (Usable range: 0 <math>\longleftrightarrow</math> 4 1/2 turns out)</p> <p>3 turns out from the fully clockwise position (Usable range: 0 <math>\longleftrightarrow</math> 4 turns out)</p> <p>Spring length: 178 mm (7.0 in.)</p> <p>Spring length: 173.5 ~ 191.5 mm (6.832 ~ 7.539 in.) (weaker to stronger)</p> <p>980 kPa (10 kgf/cm<sup>2</sup>, 142 psi, non-adjustable)</p>

Special Tools

Inside Circlip Pliers:  
57001-143

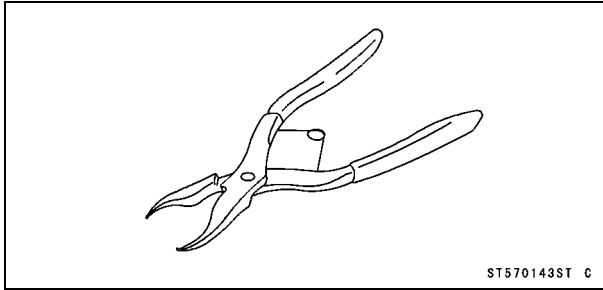

Fork Cylinder Holder:  
57001-1287

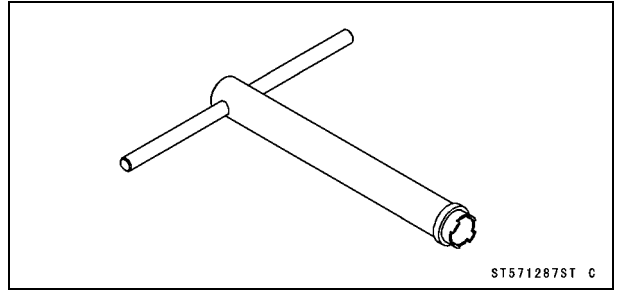

Oil Seal & Bearing Remover:  
57001-1058

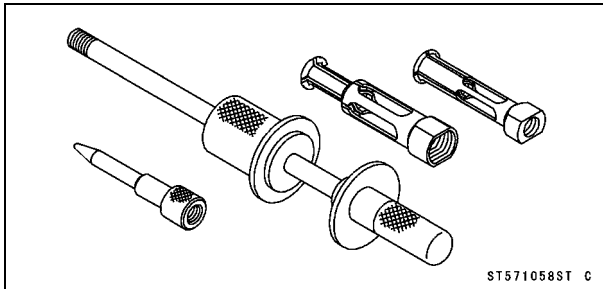

Fork Oil Level Gauge:  
57001-1290

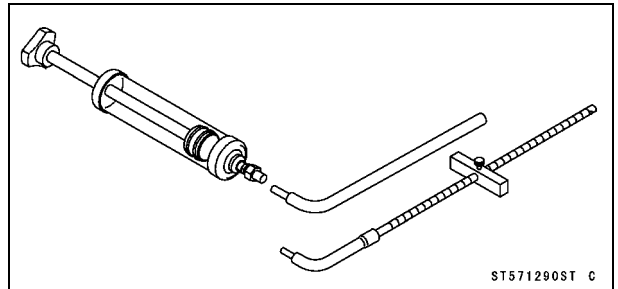

Hook Wrench R37.5, R42:  
57001-1101

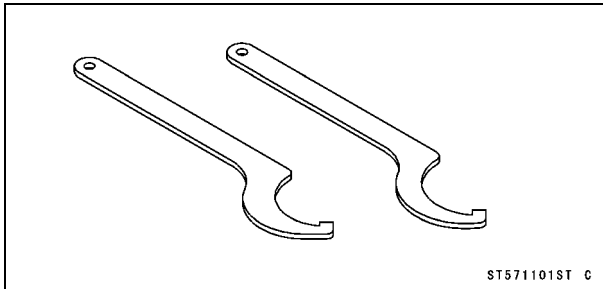

Bearing Remover Head,  $\phi 20 \times \phi 22$ :  
57001-1293

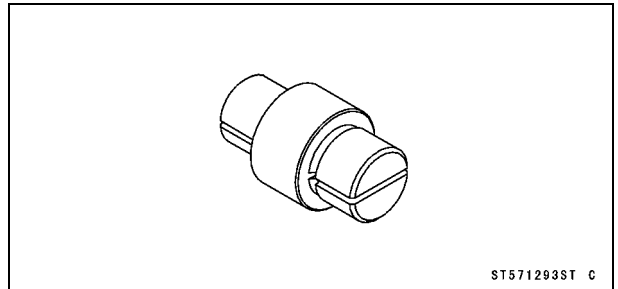

Bearing Driver Set:  
57001-1129

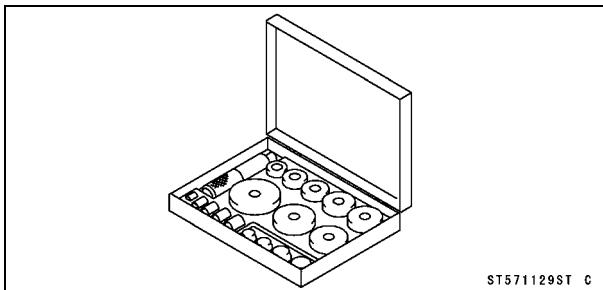

Fork Piston Rod Puller, M10  $\times$  1.0:  
57001-1298

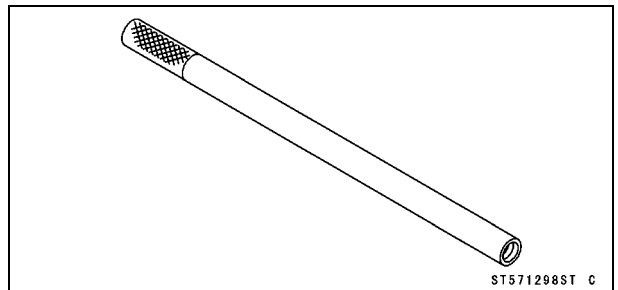

Jack:  
57001-1238

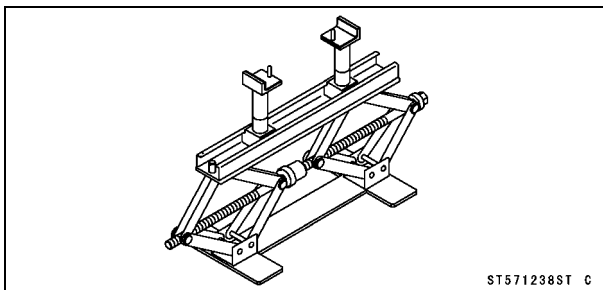

Bearing Remover Shaft,  $\phi 13$ :  
57001-1377

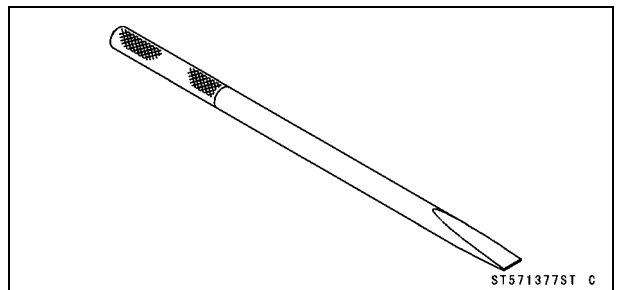

# 13-8 SUSPENSION

## Special Tools

**Fork Oil Seal Driver,  $\phi 43$ :**  
57001-1530

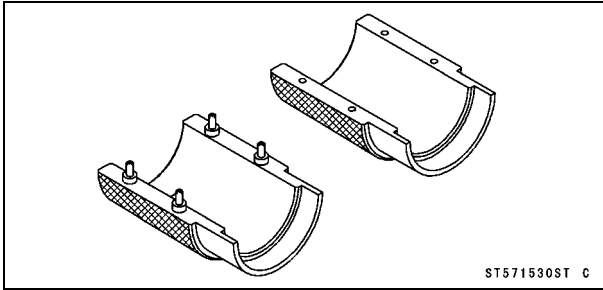

**Jack Attachment:**  
57001-1608

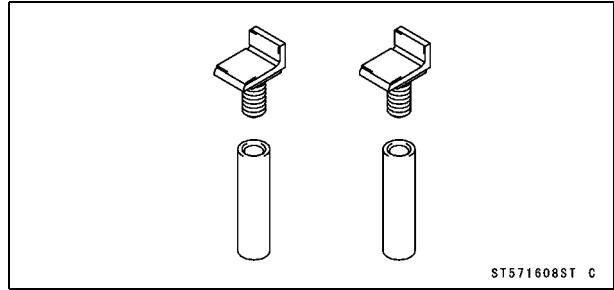

**Fork Spring Compressor:**  
57001-1540

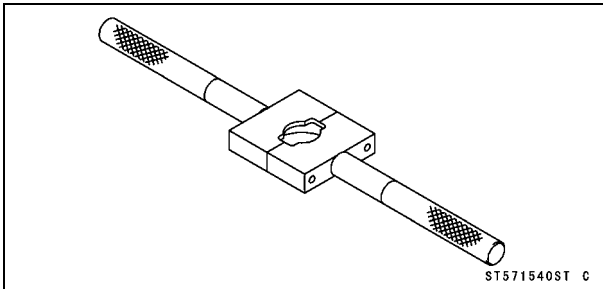

**Needle Bearing Driver,  $\phi 17/\phi 18$ :**  
57001-1609

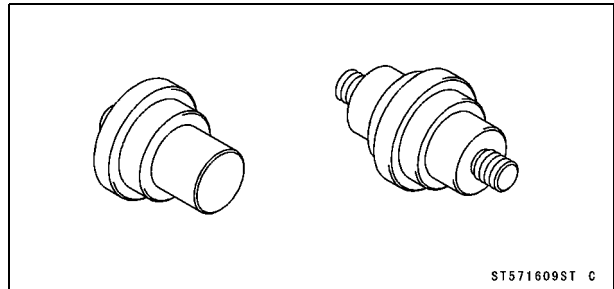

**Fork Spring Compressor:**  
57001-1587

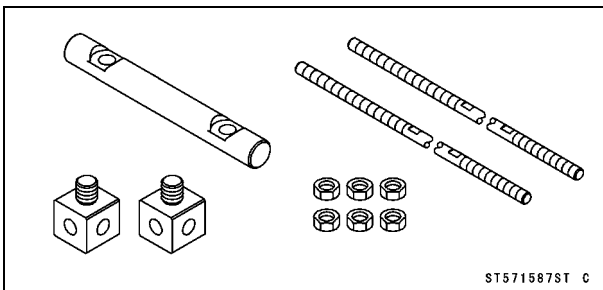

**Stem Bearing Driver,  $\phi 28$ :**  
57001-1610

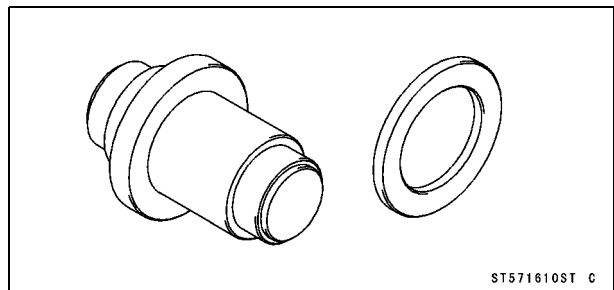

**Swingarm Pivot Nut Wrench:**  
57001-1597

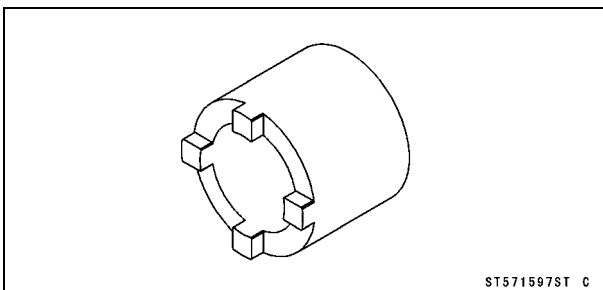



**Front Fork**

**Rebound Damping Force Adjustment**

- To adjust the rebound damping force, turn the rebound damping adjuster [A] until you feel a click.
- The standard adjuster setting for the average-build rider of 68 kg (150 lb) with no passenger and no accessories is the **9th click** from the 1st click of the fully clockwise position.

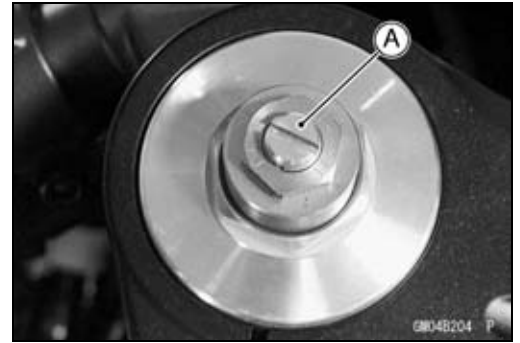

**⚠ WARNING**

**If both adjusters are not adjusted equally, handling may be impaired and a hazardous condition may result.**

- The damping force can be left soft for average riding. But it should be adjusted harder for high speed riding or riding with a passenger. If the damping feels too soft or too stiff, adjust it in accordance with the following table.

**Rebound Damping Force Adjustment**

Adjuster Position	Damping Force	Setting	Load	Road	Speed
11	Weak	Soft	Light	Good	Low
↑	↑	↑	↑	↑	↑
↓	↓	↓	↓	↓	↓
0	Strong	Hard	Heavy	Bad	High

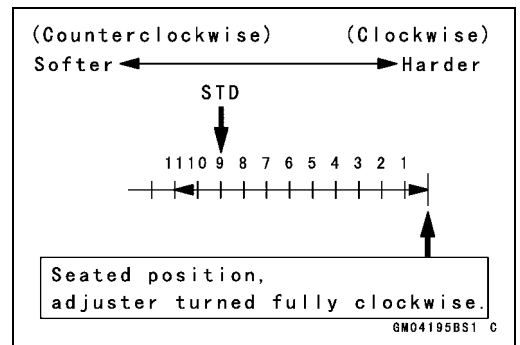

**Compression Damping Force Adjustment**

- To adjust the compression damping force, turn the compression damping adjuster [A] until you feel a click.
- The standard adjuster setting for the average-build rider of 68 kg (150 lb) with no passenger and no accessories is the **7th click** from the 1st click of the fully clockwise position.

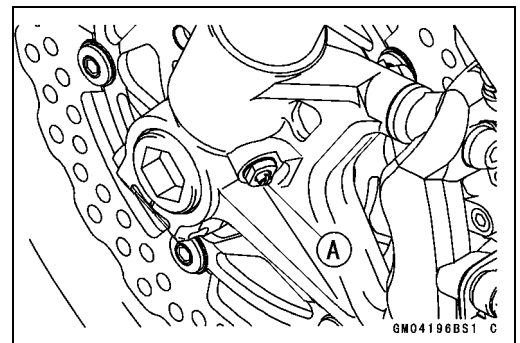

**⚠ WARNING**

**If both adjusters are not adjusted equally, handling may be impaired and a hazardous condition may result.**

- The damping force can be left soft for average riding. But it should be adjusted harder for high speed riding or riding with a passenger. If the damping feels too soft or too stiff, adjust it in accordance with the following table.

**Compression Damping Force Adjustment**

Adjuster Position	Damping Force	Setting	Load	Road	Speed
13	Weak	Soft	Light	Good	Low
↑	↑	↑	↑	↑	↑
↓	↓	↓	↓	↓	↓
0	Strong	Hard	Heavy	Bad	High

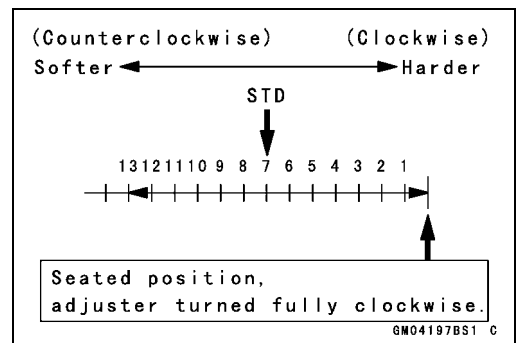

# 13-10 SUSPENSION

## Front Fork

### Spring Preload Adjustment

- Turn the spring preload adjuster [A] to change spring preload setting.
- The standard adjuster setting for the average-build rider of 68 kg (150 lb) with no passenger and no accessories is the 14 mm (0.55 in.) [B] from top as shown.

#### Adjuster Protrusion (from top)

- Standard: 14 mm (0.55 in.)
- Usable Range: 4 ~ 19 mm (0.16 ~ 0.75 in.)

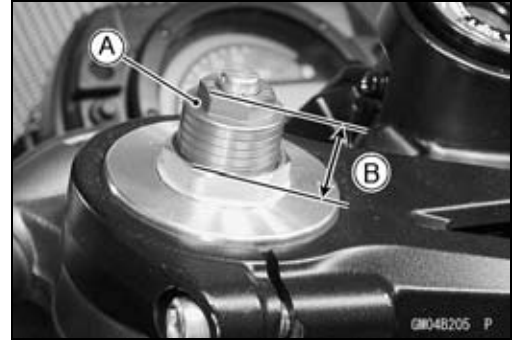

### **⚠ WARNING**

**If both adjusters are not adjusted equally, handling may be impaired and a hazardous condition may result.**

- The spring preload can be left soft for average riding. But it should be adjusted harder for high speed riding or riding with a passenger. If the spring action feels too soft or too stiff, adjust it in accordance with the following table.

### Spring Action

Adjuster Position	Damping Force	Setting	Load	Road	Speed
19 mm	Weak	Soft	Light	Good	Low
↑	↑	↑	↑	↑	↑
↓	↓	↓	↓	↓	↓
4 mm	Strong	Hard	Heavy	Bad	High

### Front Fork Removal (each fork leg)

- Remove:
  - Front Wheel (see Wheels/Tires chapter)
  - Front Fender (see Frame chapter)
- ★ Loosen the handlebar bolt [A], upper fork clamp bolt [B] and fork top plug [C] beforehand if the fork leg is to be disassembled.

#### **NOTE**

○ Loosen the top plug after loosening the handlebar holder bolt and upper fork clamp bolt.

- Loosen the handlebar bolt [A], upper fork clamp bolt [B] and lower fork clamp bolts [C].
- With a twisting motion, work the fork leg down and out.

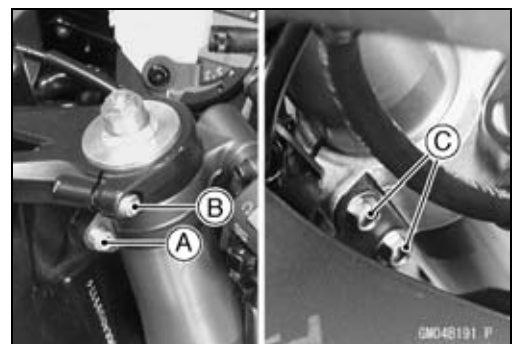
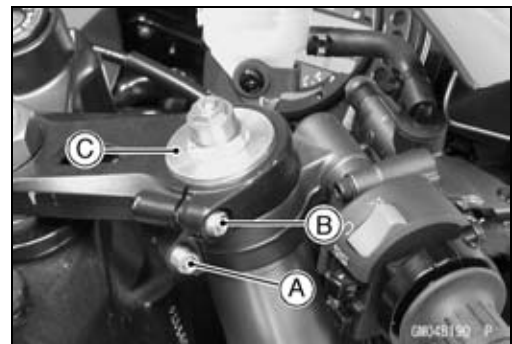

## Front Fork

### Front Fork Installation

- Install the fork so that the top end [A] of the outer tube is flush with the upper surface [B] of the steering stem head bracket.
- Tighten the lower fork clamp bolts and fork top plug.
  - Torque - Front Fork Clamp Bolts (Lower): 20 N·m (2.0 kgf·m, 14.5 ft·lb)**
  - Front Fork Top Plug: 23 N·m (2.3 kgf·m, 17 ft·lb)**
- Tighten the handlebar holder bolt upper fork clamp bolt.
  - Torque - Handlebar Holder Bolt: 25 N·m (2.5 kgf·m, 18 ft·lb)**
  - Front Fork Clamp Bolt (Upper): 30 N·m (3.0 kgf·m, 14.5 ft·lb)**

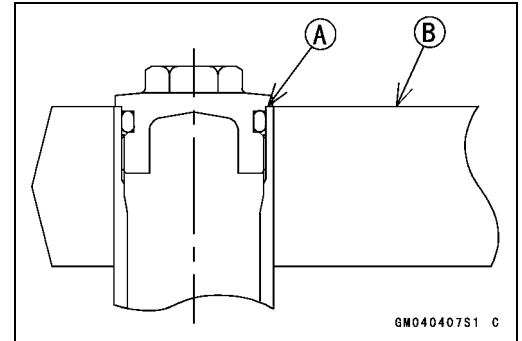

### NOTE

- Tighten the two clamp bolts alternately two times to ensure even tightening torque.
- Tighten the top plug before tightening the handlebar holder bolt upper fork clamp bolt.
- Install the removed parts (see appropriate chapters).
- Adjust the spring preload and the damping force.

### Front Fork Oil Change

- Remove the front fork (see Front Fork Removal).
- Hold the inner tube lower end in a vise.
- Unscrew the top plug [A] out of the outer tube.

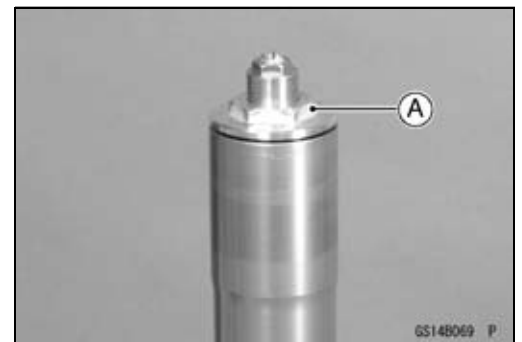

- Install the clamps [A] as shown.

### NOTE

- Set the clamps so that the cutout [B] of the upper side does not touch the tongue shape of stopper, pull up the outer tube [C] to hold it by the clamps, and then tighten the two bolts [D]. The outer tube is used as a guide.

**Special Tools - Fork Spring Compressor: 57001-1540**  
**Fork Spring Compressor: 57001-1587**

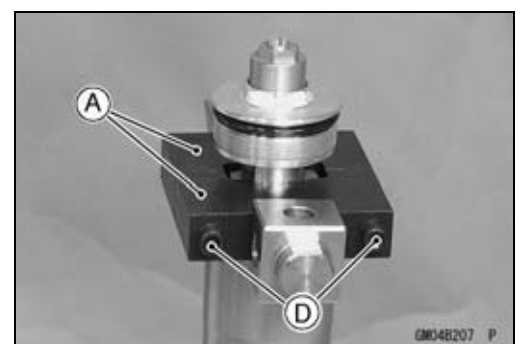
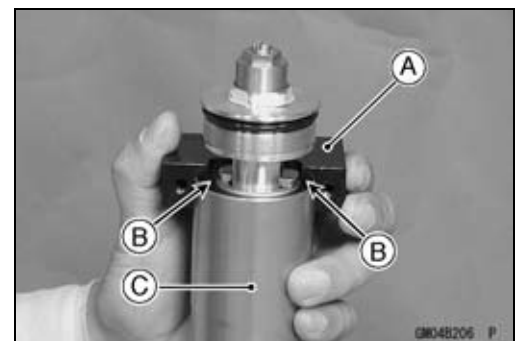

## 13-12 SUSPENSION

### Front Fork

- Insert the holder bar [A] into the axle hole of the front fork [B].

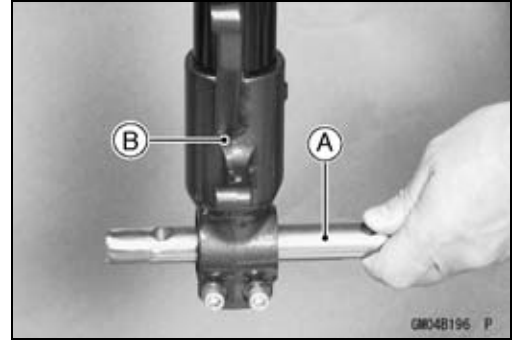

- Insert the compression shaft [A] and install the nut.

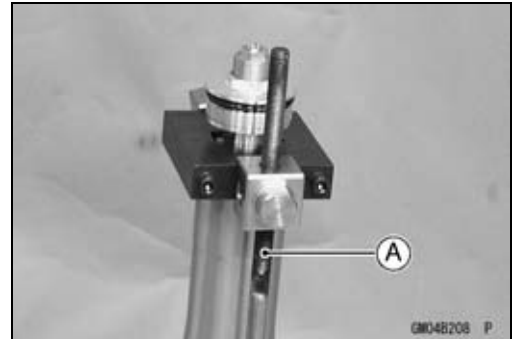

- Insert the lower end of the compression shaft [A] into the hole [B] of the holder bar.

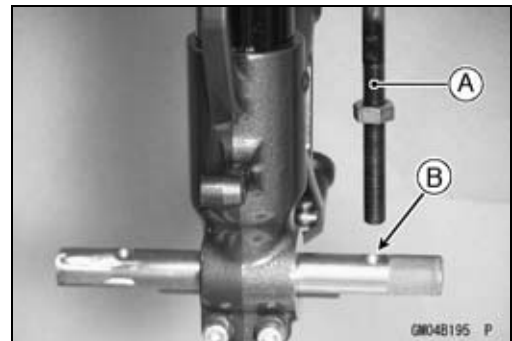

- Screw the adjust nut [A] onto the compression shaft as shown.
- Screw the locknut [B].
- Set the other side compression shaft same process.

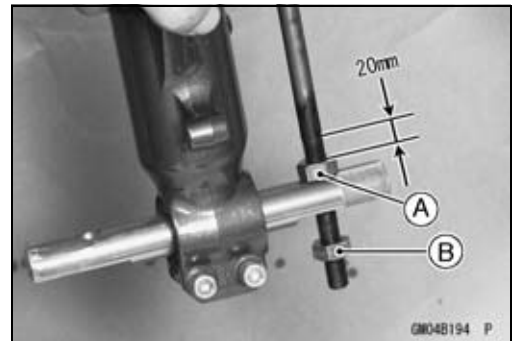

- Screw in one side nut [A] come out the piston rod nut.

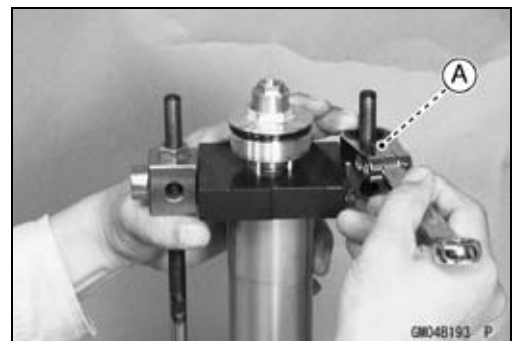

**Front Fork**

- Holding the piston rod nut with a wrench [A], remove the top plug [B] from the piston rod.

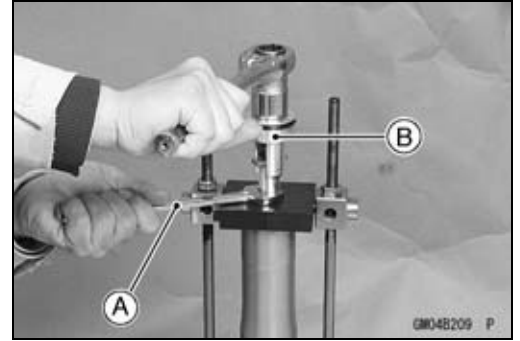

- Remove:
  - Washer [A]
  - Collar [B]
  - Rebound Damping Adjuster Rod [C]
  - Fork Spring [D]

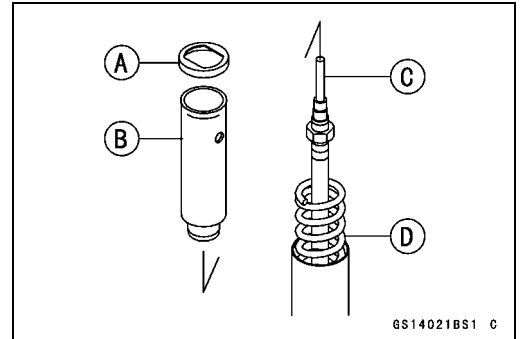

- Drain the fork oil into a suitable container.
- Pump the piston rod [B] up and down at least ten times to expel the oil from the fork.

**Special Tool - Fork Piston Rod Puller, M10 × 1.0: 57001-1298 [A]**

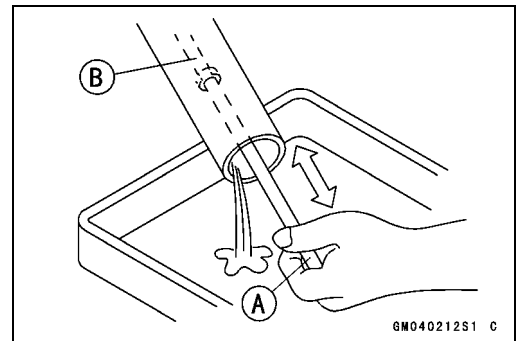

- Hold the fork tube upright, press the inner tube [A] and the piston rod all the way down.
- Pour in the type and amount of fork oil specified.

**Fork Oil**

**Viscosity:**

**KHL15-10 (KAYABA) or equivalent**

**Amount (per side):**

**When changing oil:**

**Approx. 490 mL (16.6 US oz.) (ZX1000-C1)**

**Approx. 480 mL (16.2 US oz.) (ZX1000-C2)**

**After disassembly and completely dry:**

**576 ±4 mL (19.5 ±0.14 US oz.) (ZX1000-C1)**

**565 ±4 mL (19.1 ±0.14 US oz.) (ZX1000-C2)**

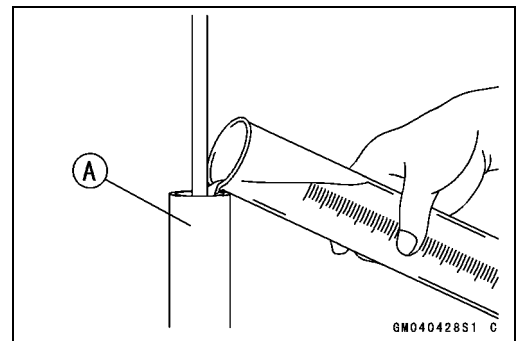

# 13-14 SUSPENSION

## Front Fork

- ★ If necessary, measure the oil level as follows.
- Hold the inner tube vertically in a vise.
- Pump the inner tube several times to expel air bubbles.
- Using the piston rod puller [A], move the piston rod [B] up and down more than ten times in order to expel all the air from the fork oil.

**Special Tool - Fork Piston Rod Puller, M10 × 1.0: 57001-1298**

- Remove the piston rod puller.
- Wait until the oil level settles.
- With the fork fully compressed and the piston rod fully pushed in, insert a tape measure or rod into the inner tube, and measure the distance from the top of the outer tube to the oil.

**Oil Level (fully compressed, without spring)**

**Standard: 91 ± 2 mm (3.58 ± 0.08 in.) (ZX1000-C1)**

**101 ± 2 mm (3.98 ± 0.08 in.) (ZX1000-C2)**  
(from the top of the outer tube)

### NOTE

- Fork oil level may also be measured using the fork oil level gauge.

**Special Tool - Fork Oil Level Gauge: 57001-1290 [A]**

- With the fork fully compressed and without fork spring, insert the gauge tube into the inner tube [B] and position the stopper across the top end [F] of the outer tube [C].
- Set the gauge stopper [D] so that its lower side shows the oil level distance specified [E].
- Pull the handle slowly to pump out the excess oil until the oil no longer comes out.
- ★ If no oil is pumped out, there is insufficient oil in the inner tube. Pour in enough oil, then pump out the excess oil as shown above.

- Screw the fork piston rod puller onto the end of the piston rod.

**Special Tool - Fork Piston Rod Puller, M10 × 1.0: 57001-1298**

- Pull the puller up above the outer tube top.
- Install the fork spring [A] with the smaller end facing [B] upward.
- Install:
  - Spring Seat
  - Collar

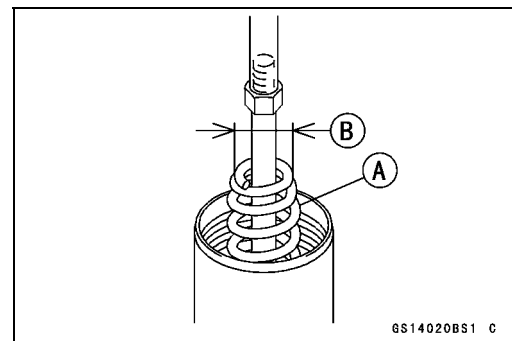
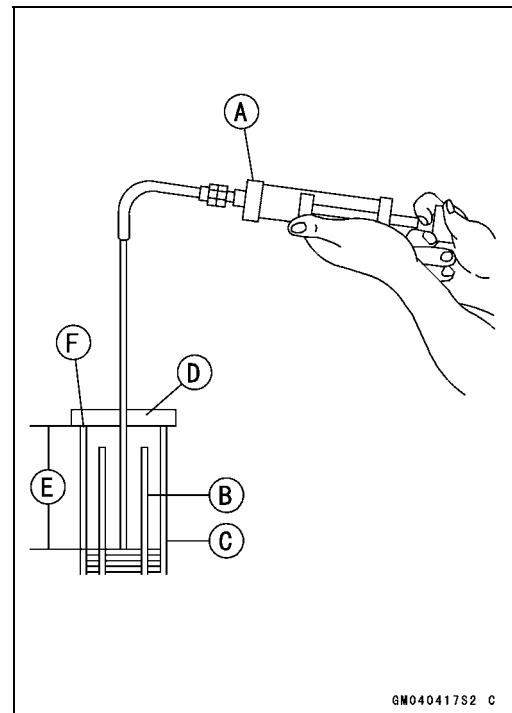
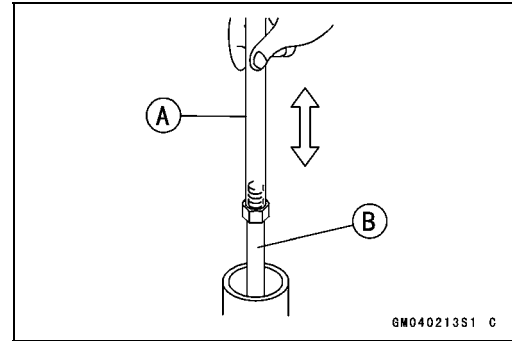

## Front Fork

- Screw the rod nut [B] onto the piston rod [A] as shown.

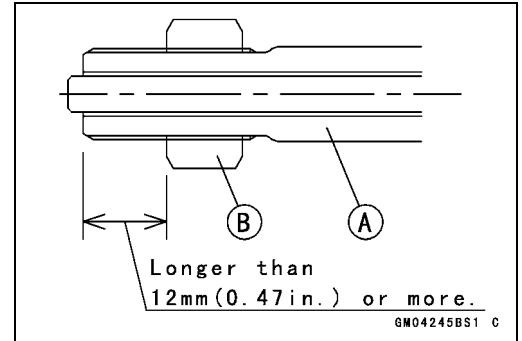

- Check the distance [C] between the bottom end [A] of the top plug and rebound damping adjuster [B] with a pair of vernier caliper.

[C]: 13 mm (0.51 in.)

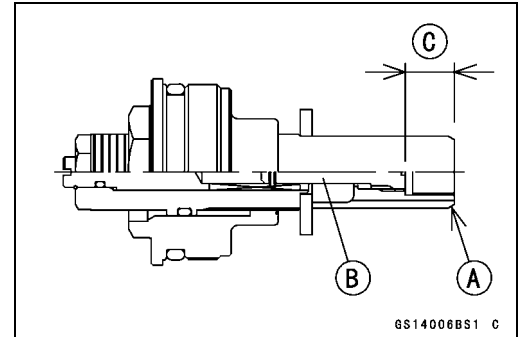

- Set the fork spring compressor on the washer using the outer tube as a guide.

**Special Tools - Fork Spring Compressor: 57001-1540**

**Fork Spring Compressor: 57001-1587**

### NOTE

- Set the clamps so that the cutout [A] of the upper side does not fit the hole [B] of washer [C], pull up the outer tube [D] to hold it by the clamps, and then tighten the two bolts [E]. The outer tube is used as a guide.

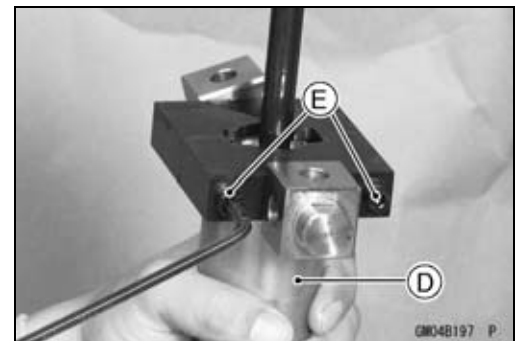
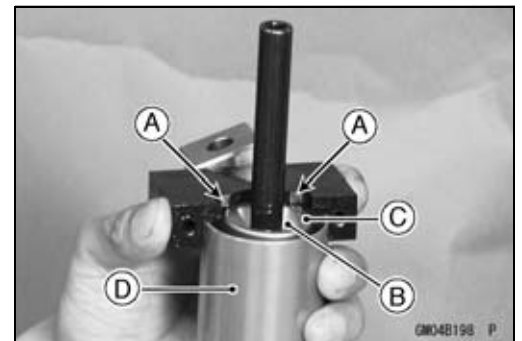

- Set the holder bar [A], and compression shafts [B].

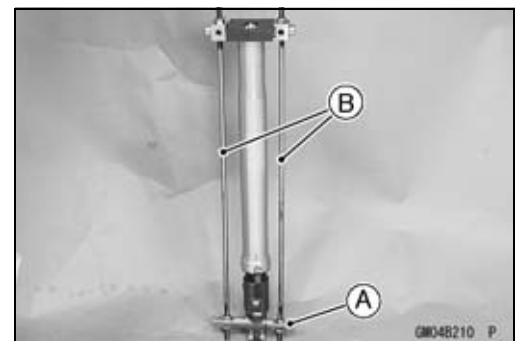

## 13-16 SUSPENSION

### Front Fork

- Hold the piston rod nut [A].
- Remove the piston rod puller [B].

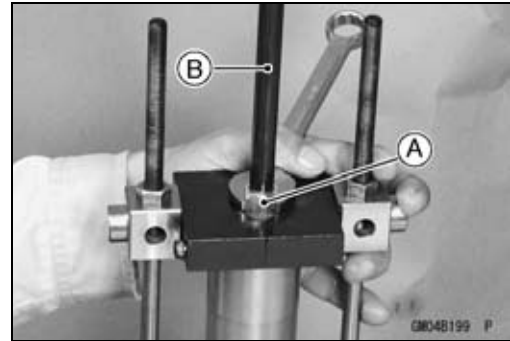

- Install the rebound damping adjuster rod [A].

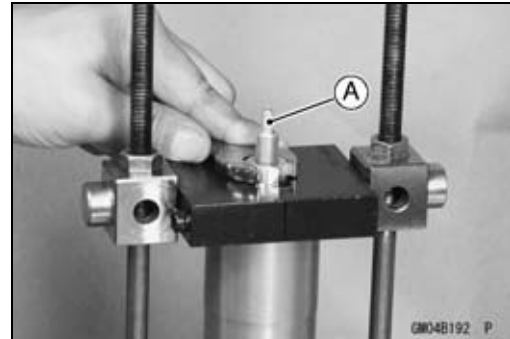

- Screw in the top plug [A] stopped onto the piston rod.
- Check the O-ring [B] on the top plug and replace it with a new one if damaged.
- Holding the top plug with a wrench, tighten the piston rod nut [C] against the top plug.

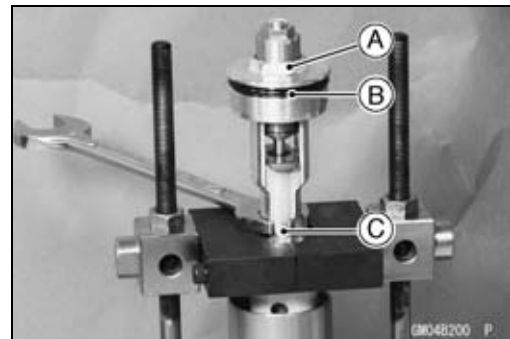

**Torque - Piston Rod Nut: 15 N·m (1.5 kgf·m, 11 ft·lb)**

- While holding up the fork spring compressor, pull out the fork spring stopper.
- Remove the fork spring compressor.

- Raise the outer tube and screw the top plug into it and install it to the steering stem.
- Screw in the spring preload adjuster [A] of the top plug so that the distance between the adjuster top and the top plug surface is 14 mm (0.55 in.) [B].
- Turn in the rebound damping adjuster [D] until the fully tightened position and turn backward the 8th click.
- Install the front fork (see Front Fork Installation).

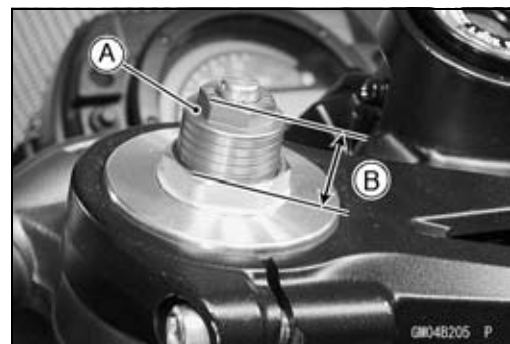

#### Front Fork Disassembly

- Remove the front fork (see Front Fork Removal).
- Drain the fork oil (see Front Fork Oil Change).
- Hold the front fork in a vise [A].
- Stop the cylinder [B] from turning by using the fork cylinder holder [C].

**Special Tool - Fork Cylinder Holder: 57001-1287**

- Unscrew the Allen bolt [D], then take the bolt and gasket out of the bottom of the inner tube.

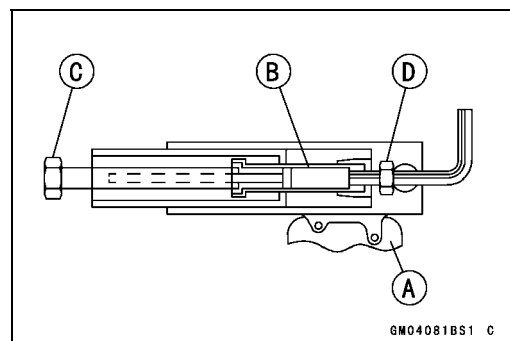



**Front Fork**

- Take the cylinder unit [A].
- Do not disassemble the cylinder unit.

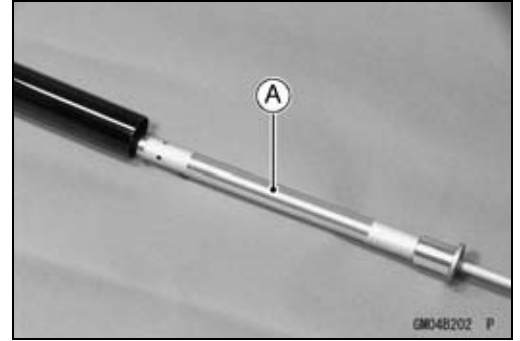

- Separate the outer tube from the inner tube.
- Pull out the dust seal.
- Remove the retaining ring [A] from the outer tube.
- Remove the oil seal [B] and washer [C].

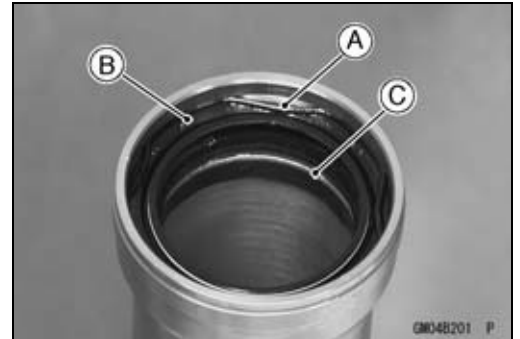

**Front Fork Assembly**

- Replace the following parts with a new one.
  - Oil Seal
  - Bottom Allen Bolt Gasket

- Insert the cylinder unit [A] into the inner tube [B].
- Stop the cylinder from turning by using the fork cylinder holder.

**Special Tool - Fork Cylinder Holder: 57001-1287**

- Apply a non-permanent locking agent to the Allen bolt and tighten it.

**Torque - Front Fork Bottom Allen Bolt: 23 N·m (2.3 kgf·m, 17 ft·lb)**

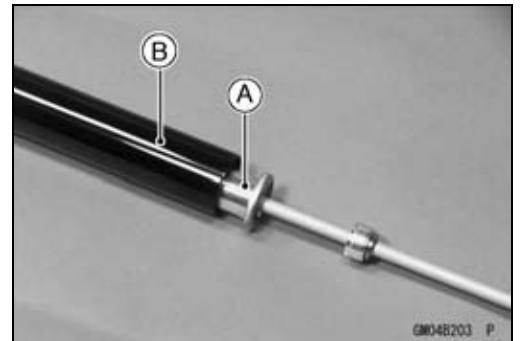

- Install the following parts into the inner tube [A].
  - Dust Seal [B]
  - Circlip [C]
  - Oil Seal [D]
  - Washer [E]

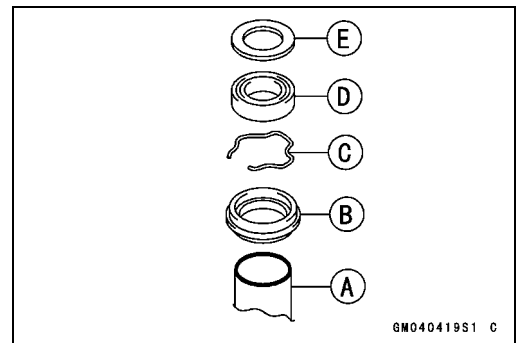

## 13-18 SUSPENSION

### Front Fork

- Insert the inner tube to the outer tube.
- After installing the washer, install the oil seal [A] by using the fork oil seal driver [B].

**Special Tool - Fork Oil Seal Driver,  $\phi$ 43: 57001-1530**

- Install the circlip and dust seal.
- Pour in the specified type of oil (see Front Fork Oil Change).

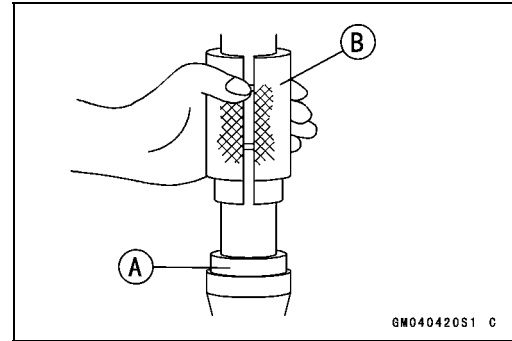

#### Inner Tube Inspection

- Visually inspect the inner tube [A], and repair any damage.
- Nicks or rust damage can sometimes be repaired by using a wet-stone to remove sharp edges or raised areas which cause seal damage.
- ★ If the damage is not repairable, replace the inner tube. Since damage to the inner tube damages the oil seal, replace the oil seal whenever the inner tube is repaired or replaced.

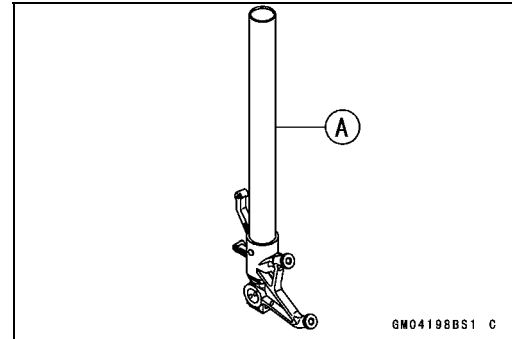

#### CAUTION

**If the inner tube is badly bent or creased, replace it. Excessive bending, followed by subsequent straightening, can weaken the inner tube.**

- Temporarily assemble the inner and outer tubes, and pump them back and forth manually to check for smooth operation.
- If you feel binding or catching, the inner and outer tubes must be replaced.

#### ⚠ WARNING

**A straightened inner or outer fork tube may fall in use, possibly causing an accident. Replace a badly bent or damaged inner or outer tube and inspect the other tube carefully before reusing it.**

#### Dust Seal Inspection

- Inspect the dust seals [A] for any signs of deterioration or damage.
- ★ Replace it if necessary.

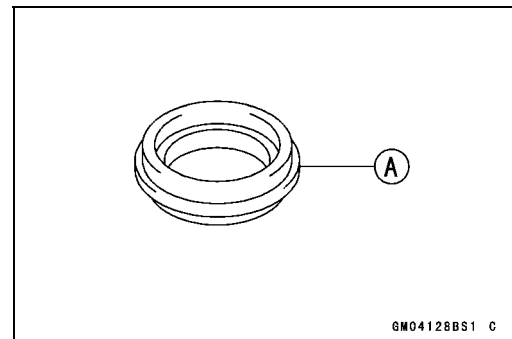

## Front Fork

### Spring Tension

- Since a spring becomes shorter as it weakens, check its free length [A] to determine its condition.
- ★ If the spring of either fork leg is shorter than the service limit, it must be replaced. If the length of a replacement spring and that of the remaining spring vary greatly, the remaining spring should also be replaced in order to keep the fork legs balanced for motorcycle stability.

### Spring Free Length

**Standard:** 245.3 mm (9.66 in.)

**Service Limit:** 243 mm (9.58 in.)

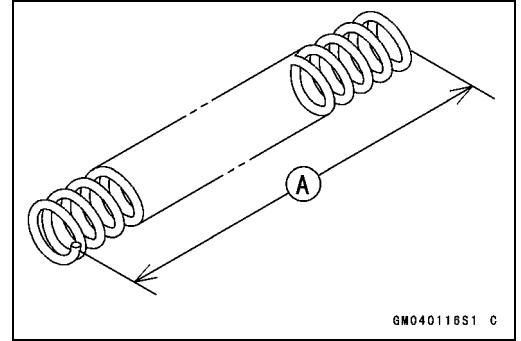

# 13-20 SUSPENSION

## Rear Shock Absorber

### Rebound Damping Force Adjustment

- To adjust the rebound damping force, turn the lower damping adjuster [A] to the desired position, until you feel a click.
- The standard adjuster setting for an average-build rider of 68 kg (150 lb) with no passenger and no accessories is the **1 3/4 turns out** from the fully clockwise position.

### Rebound Damping Force Adjustment

Adjuster Position	Damping Force	Setting	Load	Road	Speed
4 1/2 Turns Out	Weak	Soft	Light	Good	Low
↑	↑	↑	↑	↑	↑
↓	↓	↓	↓	↓	↓
0	Strong	Hard	Heavy	Bad	High

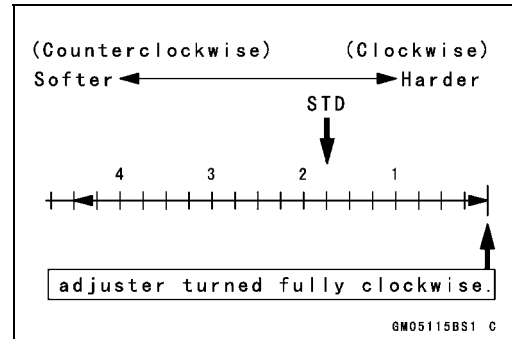

### Compression Damping Force Adjustment

- To adjust the compression damping force, turn the upper damping adjuster [A] to the desired position until you feel a click.
- The standard adjuster setting for the average-build rider of 68 kg (150 lb) with no passenger and no accessories is the **3 turns out** from the fully clockwise position.

### Rebound Damping Force Adjustment

Adjuster Position	Damping Force	Setting	Load	Road	Speed
4 Turns Out	Weak	Soft	Light	Good	Low
↑	↑	↑	↑	↑	↑
↓	↓	↓	↓	↓	↓
0	Strong	Hard	Heavy	Bad	High

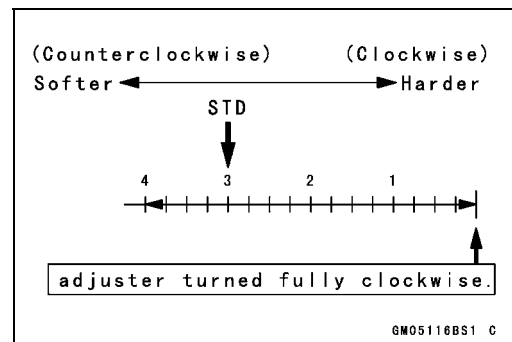

### Spring Preload Adjustment

- Remove the rear shock absorber from the frame (see Rear Shock Absorber Removal).
- Loosen the locknut and turn out the adjusting nut to free the spring.

**Special Tool - Hook Wrench: 57001-1101**

**Rear Shock Absorber**

- To adjust the spring preload, turn in the adjusting nut [A] to the desired position and tighten the locknut [B].  
[C] Spring Length

**Spring Preload Setting**

**Standard:** Spring length 178 mm (7.0 in.)

**Usable Range:** Spring length 173.5 ~ 191.5 mm (6.832 ~ 7.539 in.)

- The standard adjusting nut setting for an average-build rider of 68 kg (150 lb) with no passenger and no accessories is 180 mm (7.0 in.) spring length.

- Remove the bolts [A], chain cover [B] and left foot guard [C] for turning the hook wrench easily.

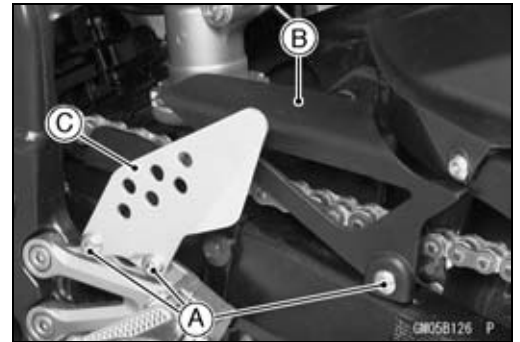
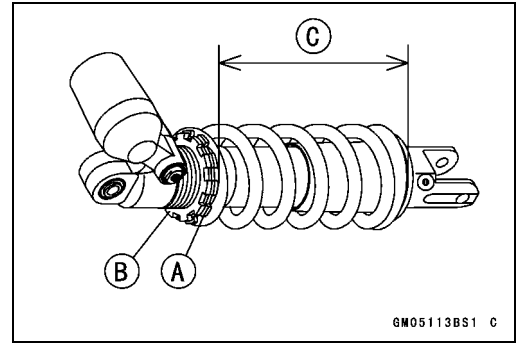

- To adjust the spring preload, turn in the adjusting nut to the desired position and tighten the locknut using by hook wrenches [A] with the rear shock absorber attached the frame.

★ If the spring action feels too soft or too stiff, adjust it.

**Spring Adjustment**

Adjuster Position	Damping Force	Setting	Load	Road	Speed
191.5 mm (7.539 in.)	Weak	Soft	Light	Good	Low
↑	↑	↑	↑	↑	↑
↓	↓	↓	↓	↓	↓
173.5 mm (6.832 in.)	Strong	Hard	Heavy	Bad	High



**Special Tool - Hook Wench: 57001-1101**

**Rear Shock Absorber Removal**

- Remove:  
Lower Fairings (see Frame chapter).  
Using the jack, raise the rear wheel off the ground.

**Special Tools - Jack: 57001-1238**

**Jack Attachment: 57001-1608**

- Squeeze the brake lever slowly and it with a band [A].

**⚠ WARNING**

**Be sure to hold the front brake when removing the shock absorber, or the motorcycle may fall over. It could cause an accident and injury.**

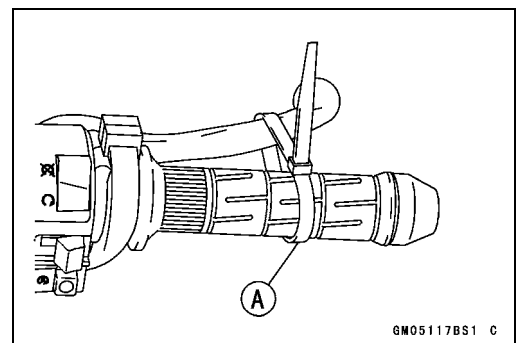

## 13-22 SUSPENSION

### Rear Shock Absorber

- Remove:
  - Lower Shock Absorber Nut and Bolt [A]
  - Upper Tie-rod Nut and Bolt [B]
  - Upper Shock Absorber Nut and Bolt [C]
- Remove the shock absorber downward.

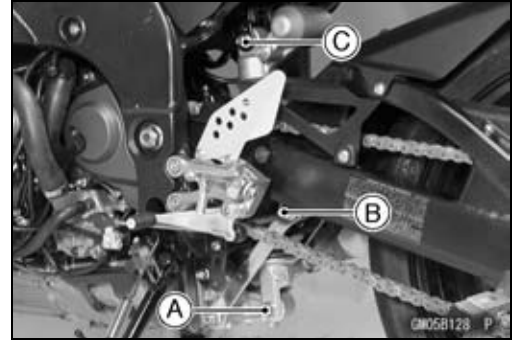

#### *Rear Shock Absorber Installation*

- Tighten:
  - Torque - Rear Shock Absorber Nuts: 34 N·m (3.5 kgf·m, 25 ft·lb)
  - Tie-rod Nuts: 59 N·m (6.0 kgf·m, 43 ft·lb)

#### *Rear Shock Absorber Inspection*

- Remove the rear shock absorber.
- Visually inspect the following items.
  - Smooth Stroke
  - Oil Leakage
  - Crack or Dent
- ★ If there is any damage to the rear shock absorber, replace it.
- Visually inspect the rubber bushing.
- ★ If it show any signs of damage, replace it.

#### *Rear Shock Absorber Scrapping*

#### **⚠ WARNING**

Since the reservoir tank of the rear shock absorber contains nitrogen gas, do not incinerate the reservoir tank without first releasing the gas or it may explode.

- Remove the valve cap and release the nitrogen gas completely from the gas reservoir.
- Remove the valve [A].

#### **⚠ WARNING**

Since the high pressure gas is dangerous, do not point the valve toward your face or body.

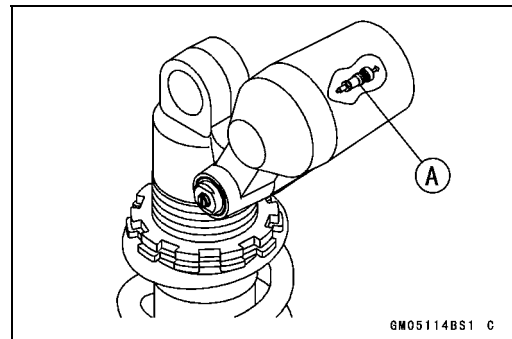

## Swingarm

### Swingarm Removal

- Remove:
  - Rear Wheel (see Wheels/Tires chapter)
  - Engine Sprocket (see Final Drive chapter)
  - Bolts [A]
  - Chain Cover

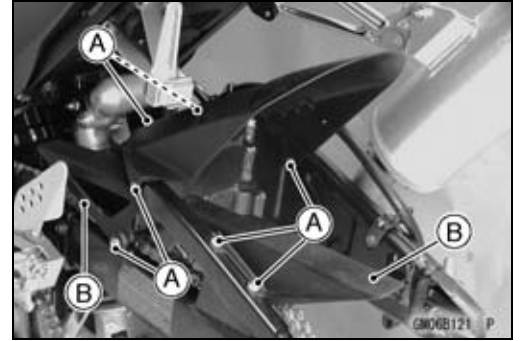

- Bolt [A]
- Brake Hose Clamps [B]
- Inner Fender [C]

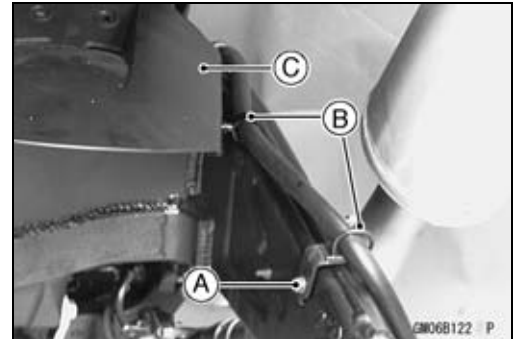

- Upper Tie-rod Nut and Bolt [A]
- Rear Shock Absorber [B] (see Rear Shock Absorber Removal)

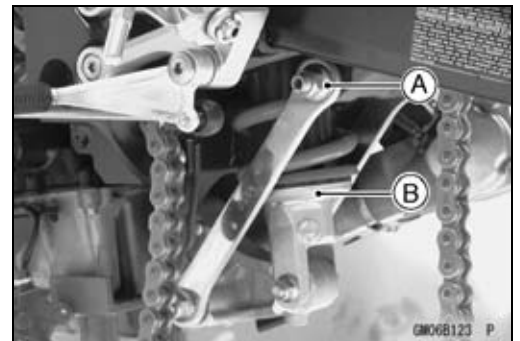

- Unscrew the swingarm pivot shaft locknut [A].

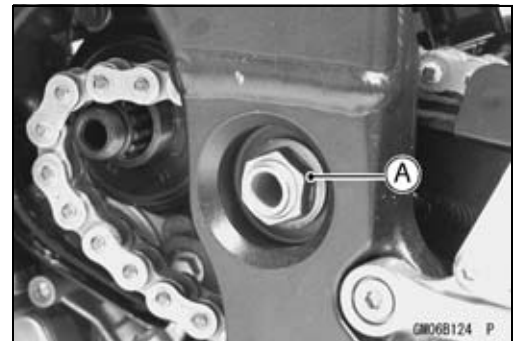

- Unscrew the swingarm pivot collar lock nut [A] using the nut wrench [B].

**Special Tool - Swingarm Pivot Nut Wrench: 57001-1597**

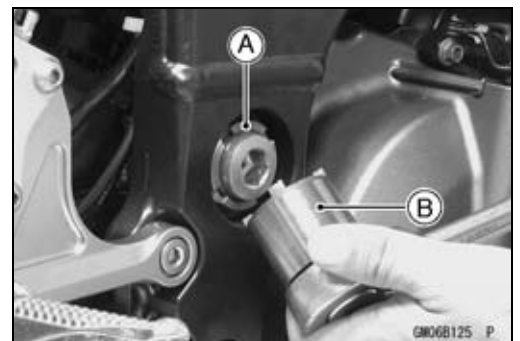

## 13-24 SUSPENSION

### Swingarm

- Unscrew the swingarm pivot shaft [A] few times.
- Turn out the swingarm pivot adjusting collar [B].
- Pull out the pivot shaft right side of the motorcycle and remove the swingarm.

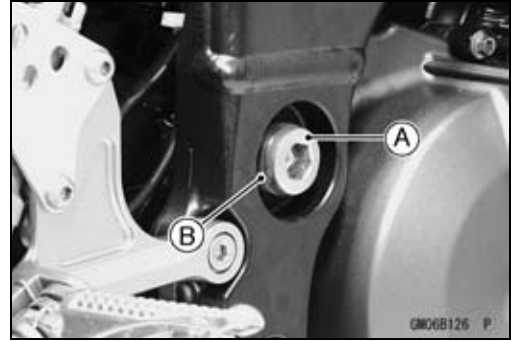

#### Swingarm Installation

- Apply plenty of grease to the lip [A] of the oil seals.
- Install the collar.

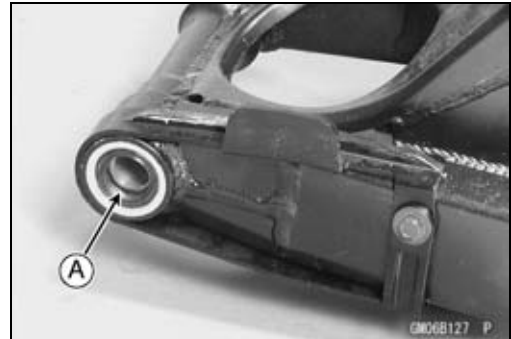

- Place the adjusting collar [A] the frame [B].

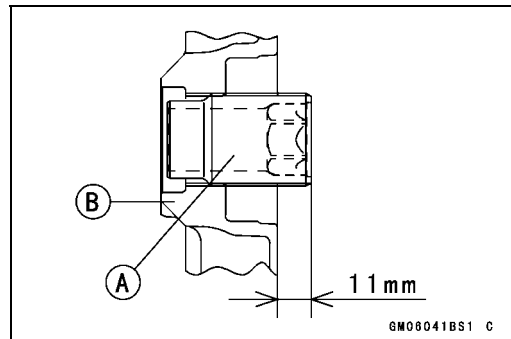

- Insert the pivot shaft [A] into the frame from the right side.
- Tighten the pivot shaft so that the clearance between the adjusting collar [B] and the ball bearing [C] come to zero mm (zero in.).

**Torque - Swingarm Pivot Adjusting Collar: 20 N·m (2.0 kgf·m, 14 ft·lb)**

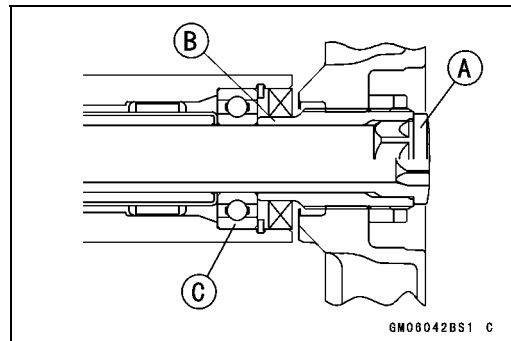

- Tighten the adjusting collar locknut [A] with the swingarm pivot nut wrench [B].

**Special Tool - Swingarm Pivot Nut Wrench: 57001-1597**

**Torque - Swingarm Pivot Adjusting Collar Locknut: 98 N·m (10 kgf·m, 72 ft·lb)**

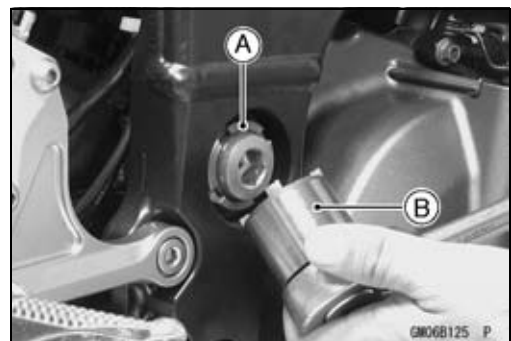



## Swingarm

- Tighten the pivot shaft nut [A].  
**Torque - Swingarm Pivot Shaft Nut: 108 N·m (11 kgf·m, 81 ft·lb)**
- Install the removed parts (see appropriate chapters).

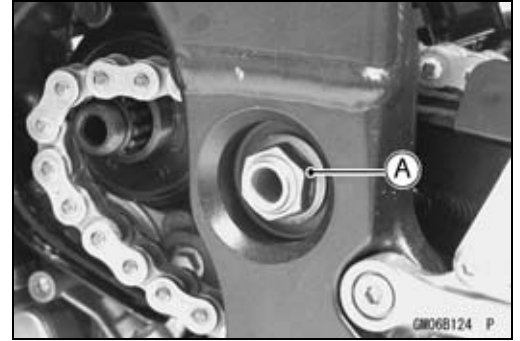

### Swingarm Bearing Removal

- Remove:
  - Swingarm
  - Collar [A]
  - Oil Seals [B]
  - Sleeve [C]
  - Circlip (right side) [D]

**Special Tool - Inside Circlip Pliers: 57001-143**

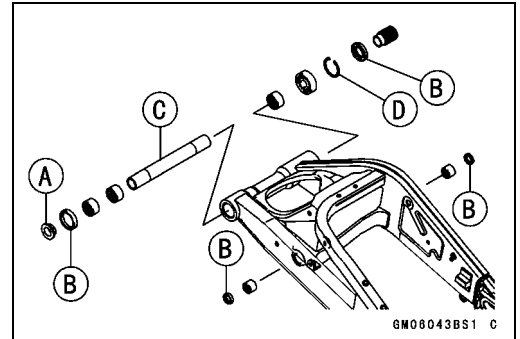

- Remove the ball bearing and needle bearings.

**Special Tools - Oil Seal & Bearing Remover: 57001-1058 [A]**  
**Bearing Remover Head: 57001-1293**  
**Bearing Remover Shaft: 57001-1377**

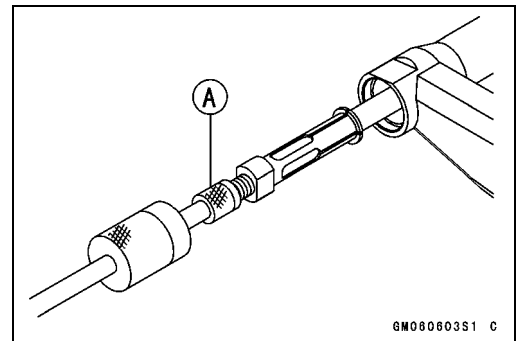

### Swingarm Bearing Installation

- Replace the ball and needle bearings with new ones.
- Install the ball and needle bearings so that the manufacturer's marks face out.

**Special Tool - Needle Bearing Driver,  $\phi 28$ : 57001-1610**

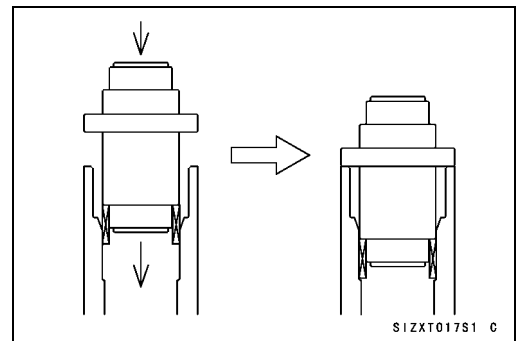

- Install the needle bearings [A], ball bearing and oil seals [C] position as shown.  
 Circlip [D]

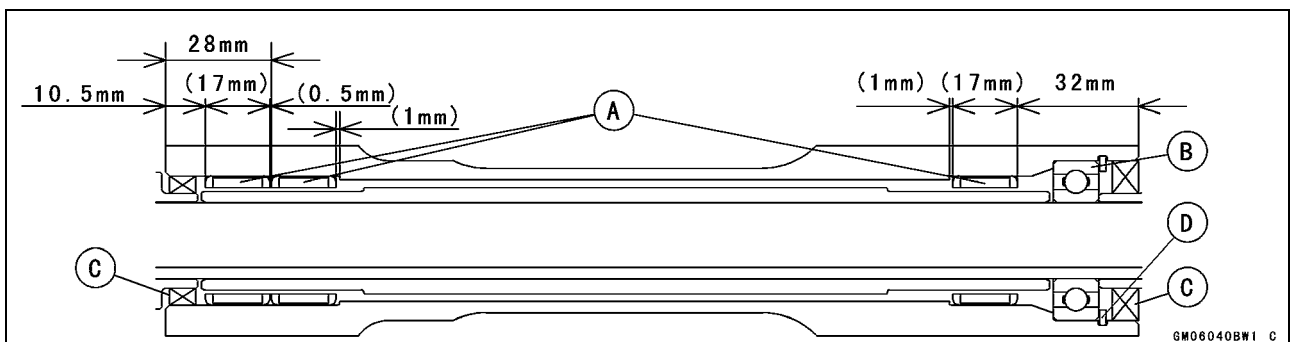

## 13-26 SUSPENSION

### Swingarm

#### Swingarm Bearing, Sleeve Inspection

<b>CAUTION</b>
----------------

<b>Do not remove the bearings for inspection. Removal may damage them.</b>
--

- Inspect the needle bearings [A] and ball bearing installed in the swingarm.
- The rollers and ball in a bearing normally wear very little, and wear is difficult to measure. Instead of measuring, visually inspect the bearing for abrasion, discoloration, or other damage.
- ★ If the needle bearing, and sleeve show any signs of abnormal wear, discoloration, or damage, replace them as a set.
  
- Turn the bearing in the coupling back and forth [A] while checking for plays, roughness, or binding.
- ★ If bearing play, roughness, or binding is found, replace the bearing.
- Examine the bearing seal [B] for tears or leakage.
- ★ If the seal is torn or is leaking, replace the bearing.

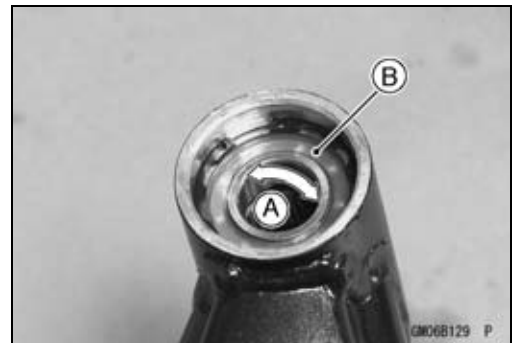
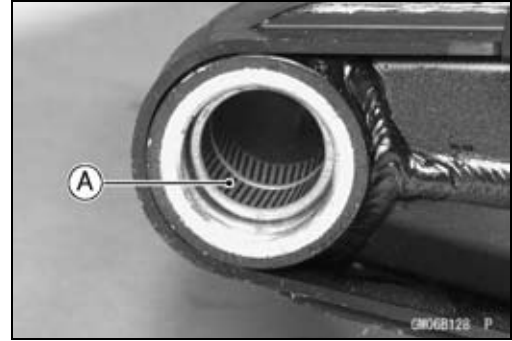

#### Swingarm Pivot Lubrication

- Refer to the Suspension in the Periodic Maintenance chapter.

#### Chain Guide Inspection

- Visually inspect the chain guide [A].
- ★ Replace the chain slider if it shows any signs of abnormal wear or damage.

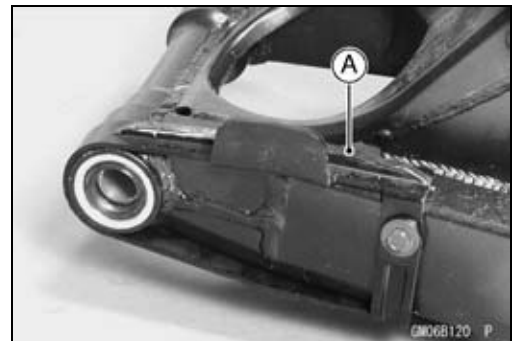

## Tie-rod, Rocker Arm

### Tie-rod Removal

- Remove the lower fairings (see Frame chapter).
- Squeeze the brake lever slowly and hold it with a band [A].

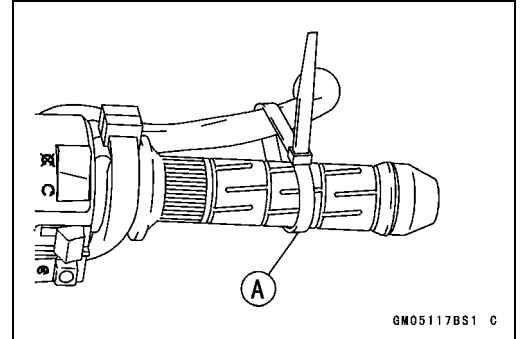

- Using the jack, raise the rear wheel off the ground.

**Special Tools - Jack: 57001-1238**

**Jack Attachment: 57001-1608**

- Remove:
  - Upper Tie-rod Bolt and Nut [A]
  - Lower Tie-rod Bolt and Nut [B]
  - Tie-rods [C]

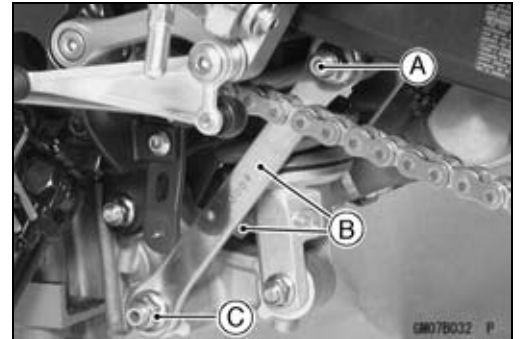

### Tie-rod Installation

- Apply grease to the inside of the grease seals.
- Install the tie-rods so that the marked side faces [A] the bolts and nuts.
- Tighten:
  - Torque - Tie-rod Nuts: 59 N·m (6.0 kgf·m, 43 ft·lb)**

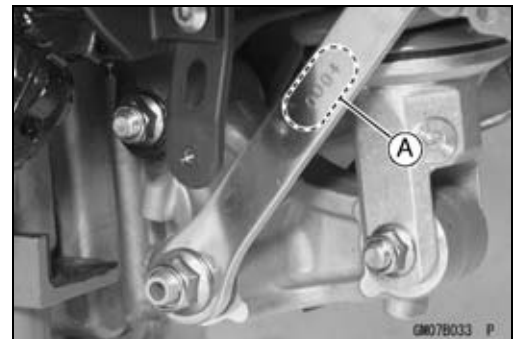

### Rocker Arm Removal

- Remove:
  - Lower Fairings (see Frame chapter)
  - Muffler (see Engine Top End chapter)
- Squeeze the brake lever slowly and hold it with a band.
- Using the jack, raise the rear wheel off the ground.

**Special Tools - Jack: 57001-1238**

**Jack Attachment: 57001-1608**

- Remove:
  - Lower Rear Shock Absorber Bolt and Nut [A]
  - Lower Tie-rod Bolt and Nut [B]
  - Rocker Arm Bolt and Nut [C]
  - Rocker Arm [D]

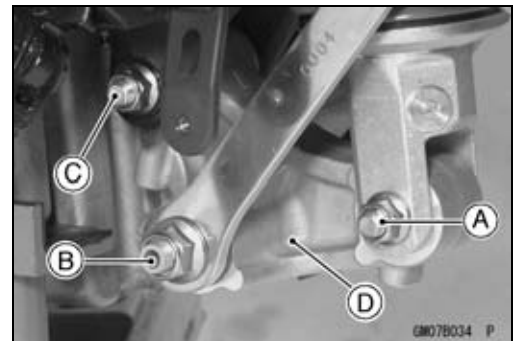

### Rocker Arm Installation

- Apply grease to the inside of the grease seals.
- Tighten:
  - Torque - Rocker Arm Nut: 34 N·m (3.5 kgf·m, 25 ft·lb)**
  - Tie-rod Nut: 59 N·m (6.0 kgf·m, 43 ft·lb)**
  - Rear Shock Absorber Nut: 34 N·m (3.5 kgf·m, 25 ft·lb)**

## 13-28 SUSPENSION

### Tie-rod, Rocker Arm

#### Tie-rod and Rocker Arm Bearing Removal

- Remove:
  - Tie-rods (see Tie-rod Removal)
  - Rocker Arm (see Rocker Arm Removal)
  - Sleeves [A]
  - Oil Seal [B]
  - Swingarm [C]
- Remove the needle bearings [D], using the bearing re-  
mover head and bearing remover shaft.

**Special Tools - Bearing Remover Head: 57001-1293**

**Bearing Remover Shaft: 57001-1377**

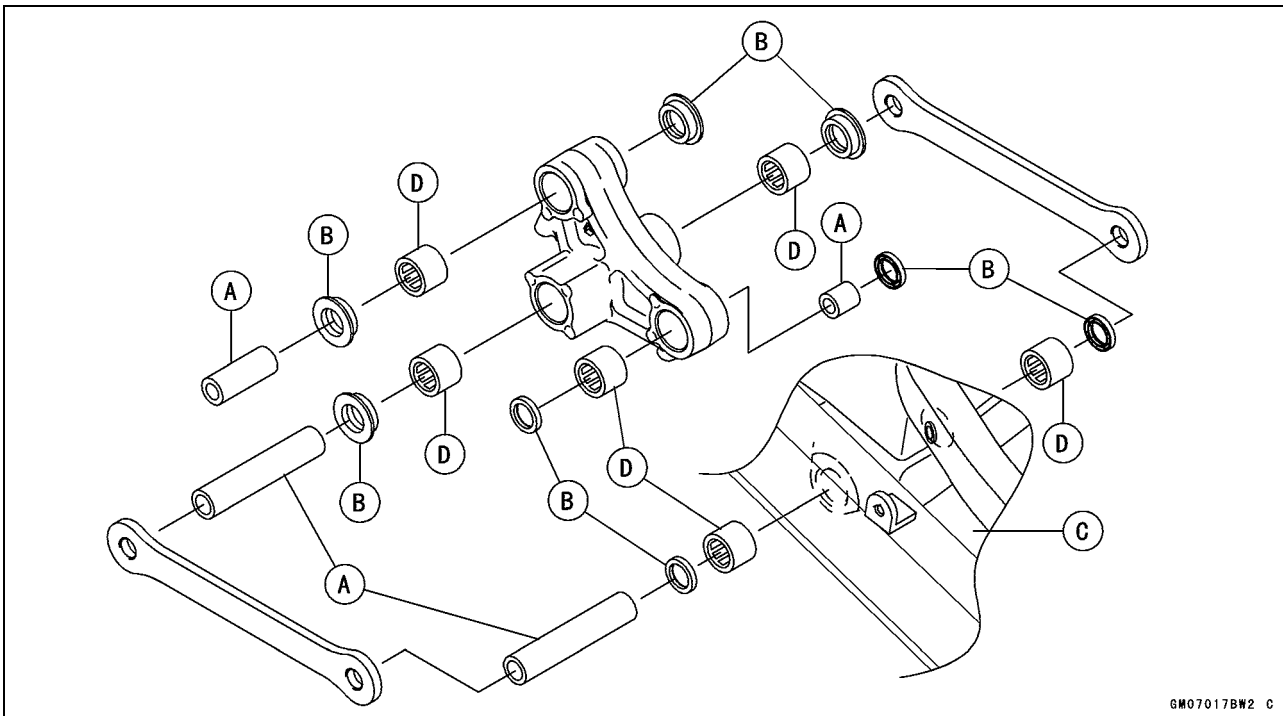

#### Tie-rod and Rocker Arm Bearing Installation

- Replace the needle bearing, and oil seals with new ones.
- Apply plenty of grease to the lips of the oil seals.
- Install the needle bearings, and oil seals position as shown.

○Screw the needle bearing driver [A] into the driver holder [B].

○Insert the needle bearing driver into the needle bearing [C] and press the needle bearing into the housing until the driver contacts the end surface of the housing.

Bearing's Pressing Depth [D]

#### NOTE

○For a bearing of inner diameter  $\phi 18$ , select the pressing side of the needle bearing driver according to its pressing depth.

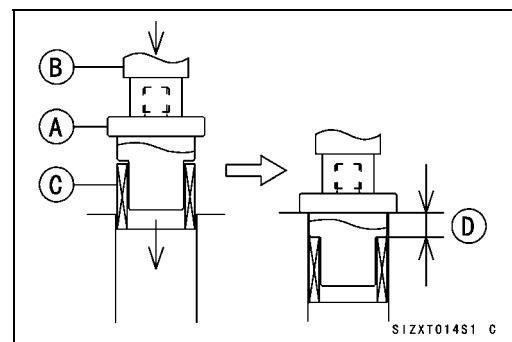

**Special Tools - Bearing Driver Set: 57001-1129**

**Needle Bearing Driver,  $\phi 17/\phi 18$ :**

**57001-1609**

**Tie-rod, Rocker Arm**

**NOTE**

○ Install the needle bearings so that the marked side faces out.

- Needle Bearing [A]
- Oil Seals [B]
- Front [C]
- Right Side [D]
- Left Side [E]
- Rear Shock Absorber [F]
- Tie-rod [H]
- Rocker Arm [I]

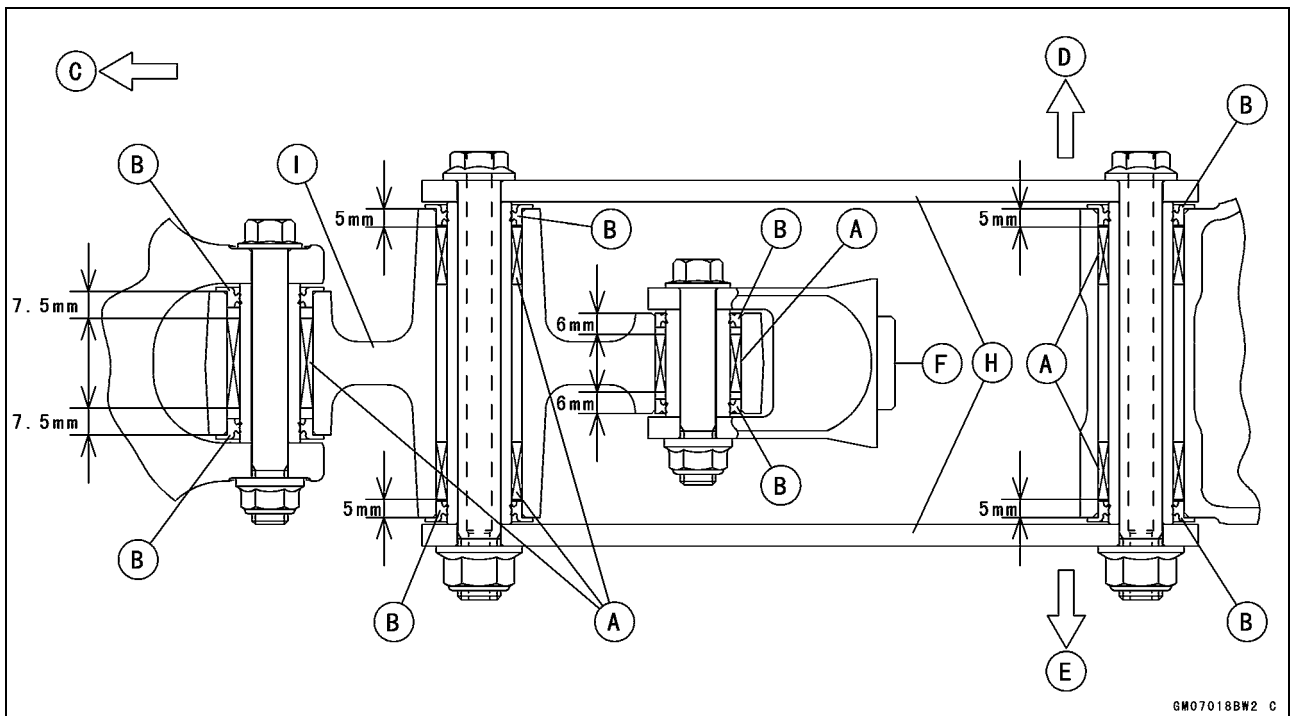

*Rocker Arm/Tie-rod Bearing, Sleeve Inspection*

**CAUTION**

**Do not remove the bearings for inspection. Removal may damage them.**

- Visually inspect the locker arm, or tie-rod sleeves [A] and needle bearings [B].
- The rollers in a needle bearing normally wear very little, and wear is difficult to measure. Instead of measuring, inspect the bearing for abrasion, color change, or other damage.
- ★ If there is any doubt as to the condition of any of the needle bearings or sleeve, replace the sleeve, and needle bearings as a set.

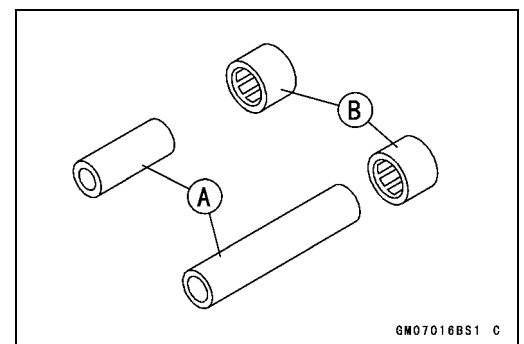

*Rocker Arm/Tie-rod Bearing Lubrication*

**NOTE**

○ Since the bearings are packed with grease, lubrication is not required.



# Steering

## Table of Contents

- Exploded View ..... 14-2
- Special Tools ..... 14-4
- Steering ..... 14-5
  - Steering Inspection ..... 14-5
  - Steering Adjustment..... 14-5
- Steering Stem..... 14-6
  - Stem, Stem Bearing Removal..... 14-6
  - Stem, Stem Bearing Installation..... 14-7
  - Steering Stem Bearing Lubrication ..... 14-9
  - Steering Stem Warp..... 14-10
  - Stem Cap Deterioration, Damage..... 14-10
- Handlebar ..... 14-11
  - Handlebar Removal ..... 14-11
  - Handlebar Installation ..... 14-11

# 14-2 STEERING

## Exploded View

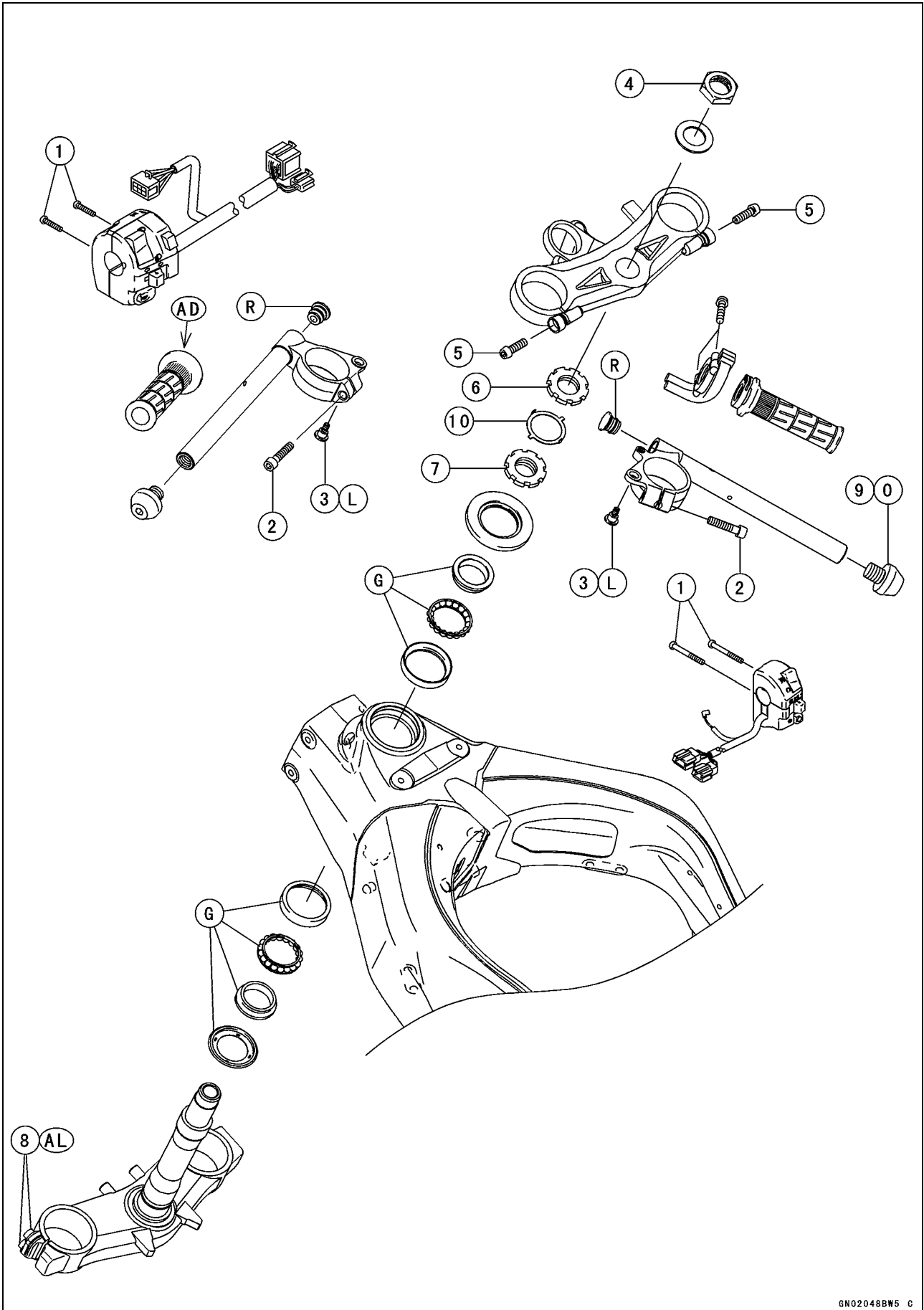



**Exploded View**

No.	Fastener	Torque			Remarks
		N·m	kgf·m	ft·lb	
1	Handlebar Switch Housing Screws	3.5	0.36	31 in·lb	
2	Handlebar Bolts	25	2.5	18	
3	Handlebar Position Bolts	9.8	1.0	87 in·lb	L
4	Steering Stem Head Nut	78	8.0	58	
5	Front Fork Clamp Bolts (Upper)	20	2.0	14.5	
6	Steering Stem Locknut	–	–	–	Hand Tighten
7	Steering Stem Nut	20	2.0	14.5	
8	Front Fork Clamp Bolts (Lower)	30	3.1	22	AL
9	Handlebar Weight Screws	29	3.0	22	O

10. Lock Washer

AD: Apply adhesive.

AL: Tighten the two clamp bolts alternately two times to ensure even tightening torque.

G: Apply grease.

L: Apply a non-permanent locking agent.

O: Apply oil.

R: Replacement Parts

# 14-4 STEERING

## Special Tools

**Bearing Puller Adapter:  
57001-136**

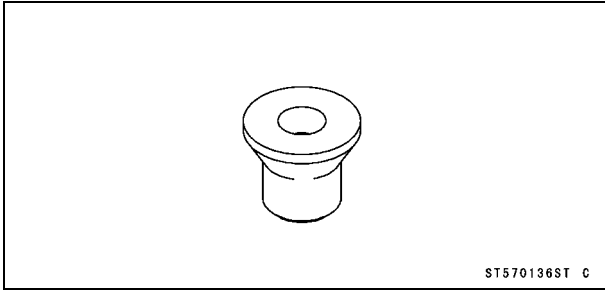

**Jack:  
57001-1238**

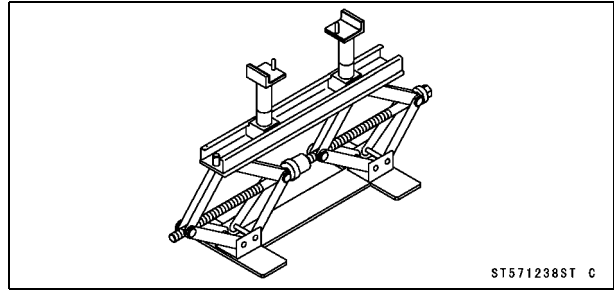

**Bearing Puller:  
57001-158**

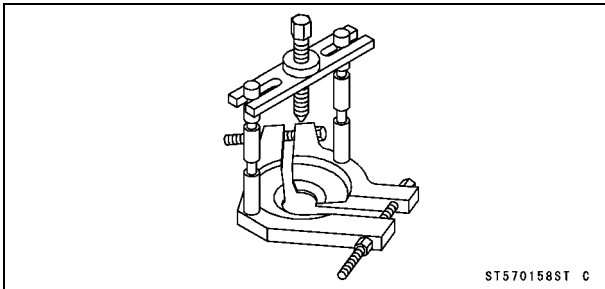

**Steering Stem Bearing Driver,  $\phi 42.5$ :  
57001-1344**

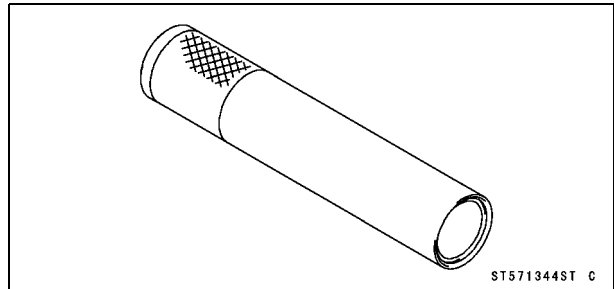

**Head Pipe Outer Race Press Shaft:  
57001-1075**

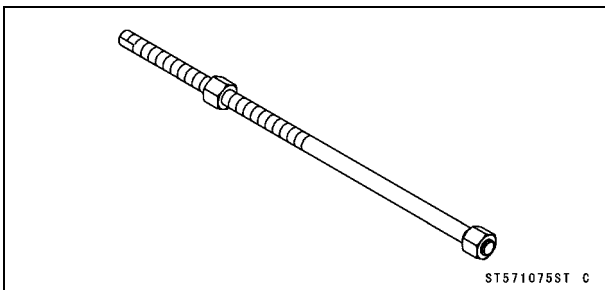

**Steering Stem Bearing Driver Adapter,  $\phi 41.5$ :  
57001-1345**

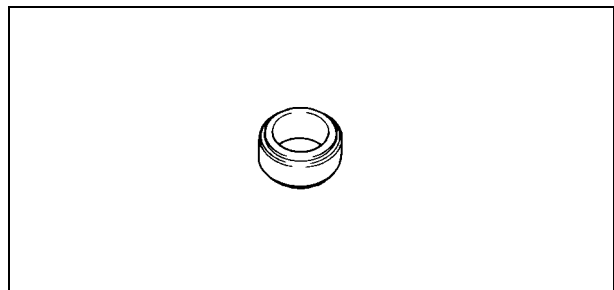

**Steering Stem Nut Wrench:  
57001-1100**

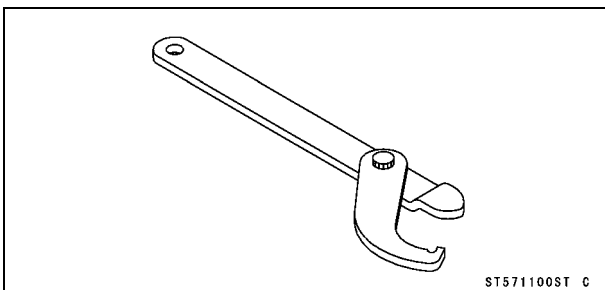

**Head Pipe Outer Race Driver,  $\phi 55$ :  
57001-1446**

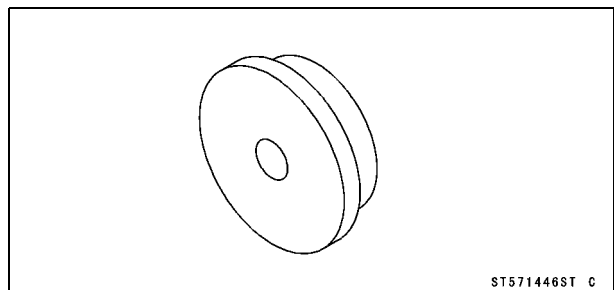

**Bearing Driver Set:  
57001-1129**

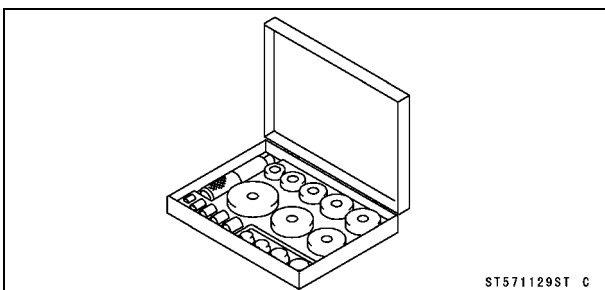

**Steering**

---

*Steering Inspection*

- Refer to the Steering Inspection in the Periodic Maintenance chapter.

*Steering Adjustment*

- Refer to the Steering Adjustment in the Periodic Maintenance chapter.

## 14-6 STEERING

### Steering Stem

#### Stem, Stem Bearing Removal

- Remove:
  - Front Wheel (see Wheels/Tires chapter)
  - Front Fork (see Suspension chapter)
  - Brake Hose Clamp Bolt [A]
  - Right Handlebar Switch Leads Clamp [B]
  - Clutch Cable Clamp [C]

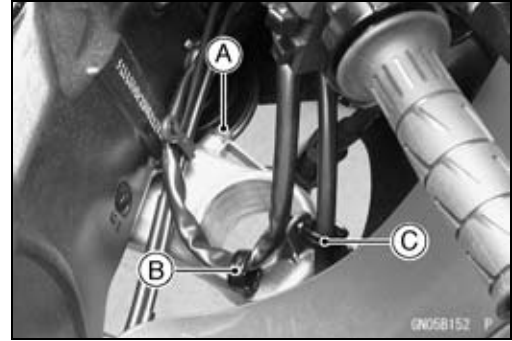

- Horn Bracket Bolt [A]
- Left Handlebar Switch Lead Clamp [B]

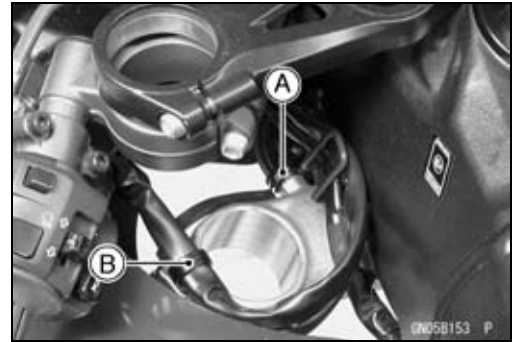

- Steering Stem Head Nut and Washer [A]
- Steering Stem Head with Handlebars [B]

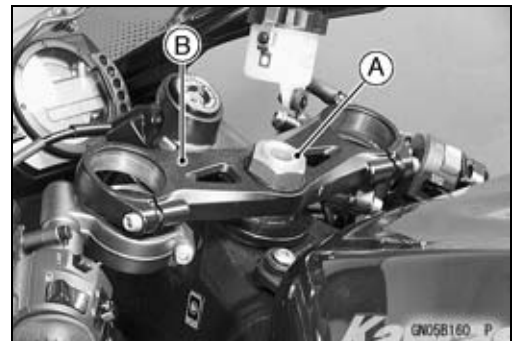

- Bend the claws [A] of lock washer straighten.
- Remove the steering stem lock nut [B].  
**Special Tool - Steering Stem Nut Wrench: 57001-1100**

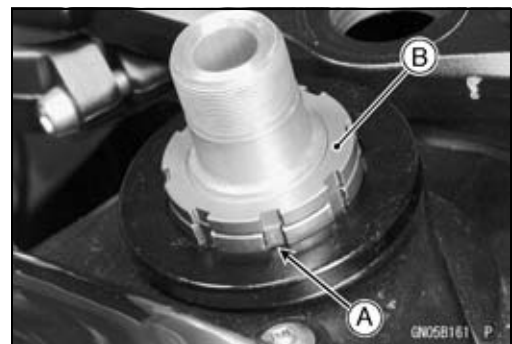

- Remove the lock washer [A].

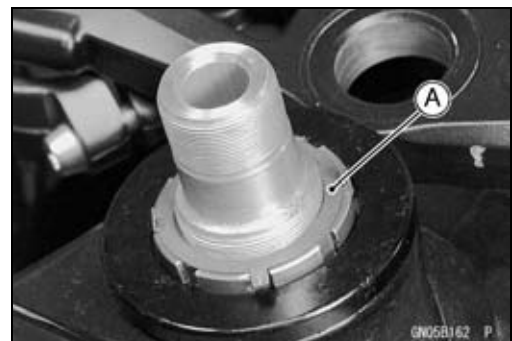

## Steering Stem

- Pushing up the stem base, and remove the steering stem nut with stem cap [A].
  - Remove:
    - Steering Stem [C]
    - Upper Ball Bearing Inner Race
- Special Tool - Steering Stem Nut Wrench [B]: 57001-1100**

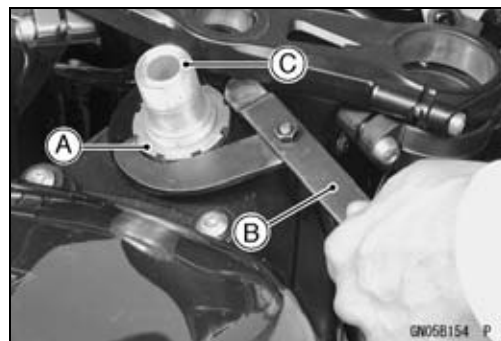

- To remove the bearing outer races [A] pressed into the head pipe [B], insert a bar [C] into the recesses [D] of head pipe, and applying it to both recess alternately hammer it to drive the race out.

### NOTE

○If either steering stem bearing is damaged, it is recommended that both the upper and lower bearings (including outer races) should be replaced with new ones.

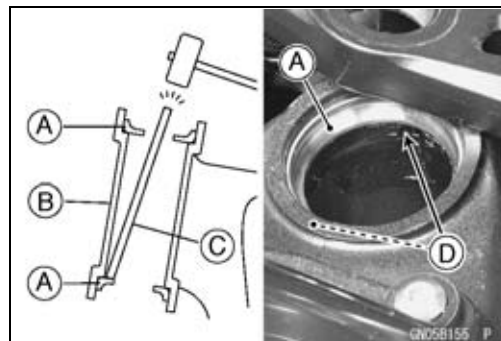

- Remove the lower bearing inner race (with its grease seal) [A] which is pressed onto the steering stem [B] with the bearing puller [C] and adapter [D].

**Special Tools - Bearing Puller Adapter: 57001-136**  
**Bearing Puller: 57001-158**

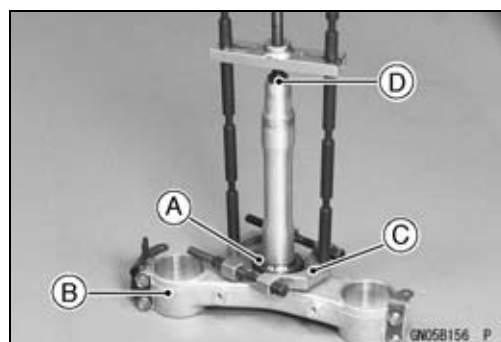

### Stem, Stem Bearing Installation

- Replace the bearing outer races with new ones.
- Drive them into the head pipe at the same time.

**Special Tools - Head Pipe Outer Race Press Shaft: 57001-1075 [A]**  
**Bearing Driver Set: 57001-1129**  
**Head Pipe Outer Race Drivers  $\phi$  55: 57001-1446 [B]**

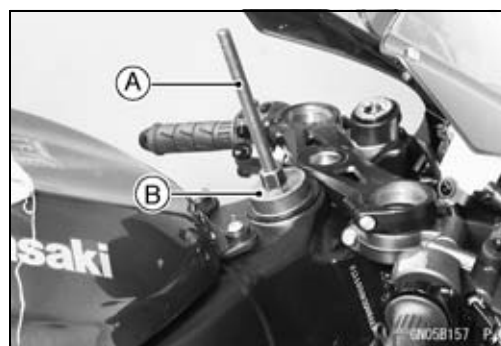

- Apply grease:
  - Outer Races

- Replace the bearing inner races with new ones.
- Install the oil seal [D] on the steering stem, and drive the lower ball bearing inner race [A] applied the grease onto the stem.

**Special Tools - Steering Stem Bearing Driver: 57001-1344 [B]**  
**Steering Stem Bearing Driver Adapter: 57001-1345 [C]**

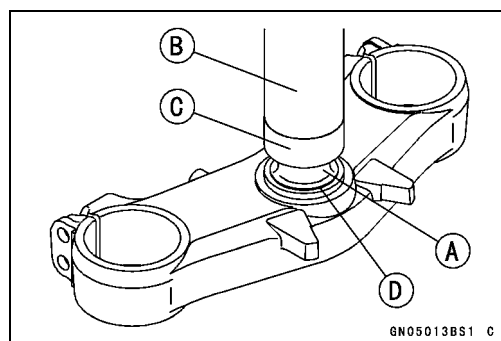

## 14-8 STEERING

### Steering Stem

- Install the lower ball bearing [A] onto the stem.
- Apply grease:
  - Inner and Outer Races
  - Lower and Upper Ball Bearings
- The lower and upper ball bearings are identical.

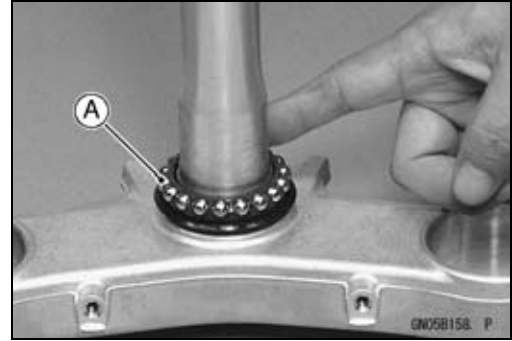

- Install the stem [A] through the head pipe and install the ball bearing [B] and inner race [C] on it.
- Install:
  - Stem Cap [D]
  - Steering Stem Nut [E]

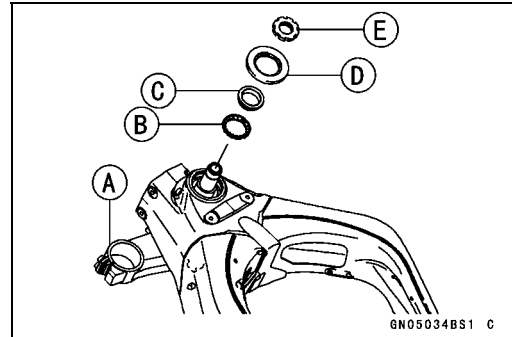

- Settle the bearings in place as follows:
  - Tighten the steering stem nut with **55 N·m (5.6 kgf·m, 41 ft·lb)** of torque first, and loosen it a fraction of a turn until it turns lightly. (To tighten the stem nut to the specified torque, hook the wrench on the stem nut, and pull the wrench at the hole by **305 N (31.0 kgf, 68.6 lb)** [B] force in the direction shown.) Afterward tighten it again with specified torque using a special tool [A].

**Special Tool - Steering Stem Nut Wrench: 57001-1100**

**Torque - Steering Stem Nut: 20 N·m (2.0 kgf·m, 14.5 ft·lb)**

- For the torque of 20 N·m (2.0 kgf·m, 14.5 ft·lb), pull the wrench at the hole by 101 N (11.1 kgf, 24.5 lb) force.
- Install the lock washer [A] so that claw [B] of washer fit the notch [C] of steering stem lock nut [D].

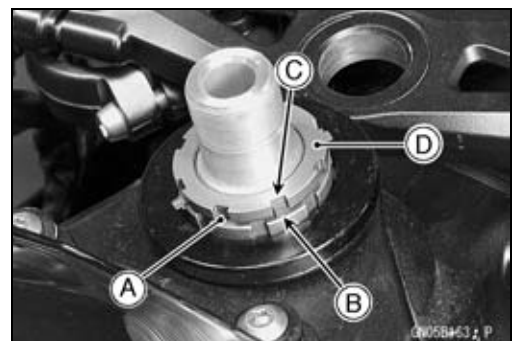
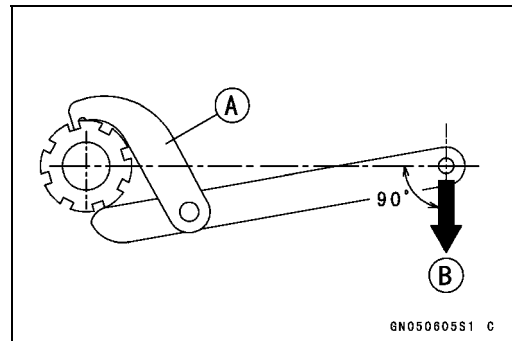

## Steering Stem

- First tighten the steering stem lock nut by hand until the resistance is felt fully, then tighten the steering stem lock nut so that align the claw [A] of stem lock nut to the notch [B] of stem nut by hand.
  - Check that there is no play and the steering stem turns smoothly without rattles. If not, the steering stem bearing may be damaged.
  - Bend the claw of lock washer [C] to steering stem nut notch.
- 
- Install the stem head [A] with handlebars to the steering stem [B].
  - Install the washer, and temporary tighten the stem head nut [C].
  - Install the front fork (see Suspension chapter).

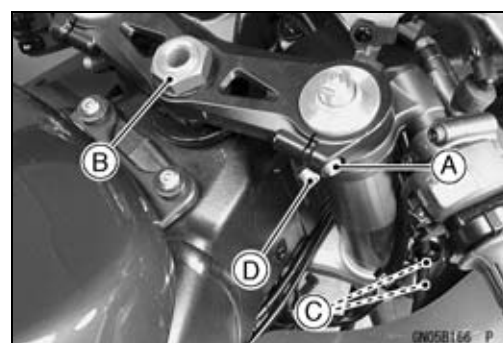
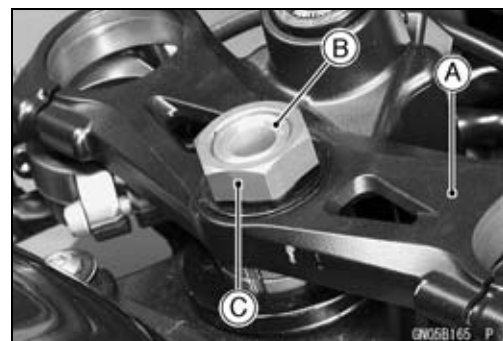
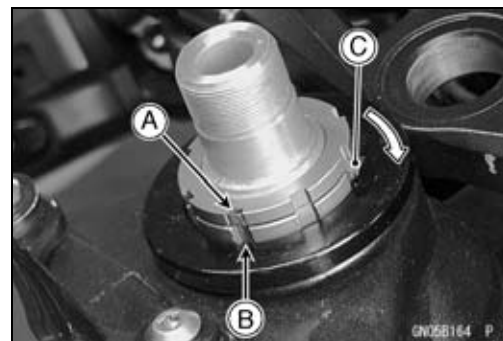

### NOTE

- Tighten the fork upper clamp bolts [A] first, next the stem head nut [B], last the fork lower clamp bolts [C] and the handlebar bolts [D].
- Tighten the two lower fork clamp bolts alternately two times to ensure even tightening torque.

**Torque - Front Fork Clamp Bolts (Upper): 20 N·m (2.0 kgf·m, 14.5 ft·lb)**

**Steering Stem Head Nut: 78 N·m (8.0 kgf·m, 58 ft·lb)**

**Front Fork Clamp Bolts (Lower): 30 N·m (3.0 kgf·m, 22 ft·lb)**

**Handlebar Bolts: 25 N·m (2.5 kgf·m, 18 ft·lb)**

### **⚠ WARNING**

**Do not impede the handlebar turning by routing the cables, harnesses and hoses improperly (see Appendix chapter).**

### *Steering Stem Bearing Lubrication*

- Refer to the Steering Stem Bearing Lubrication in the Periodic Maintenance chapter.

## 14-10 STEERING

### Steering Stem

#### *Steering Stem Warp*

- Whenever the steering stem is removed, or if the steering can not be adjusted for smooth action, check the steering stem for straightness.
- ★ If the steering stem [A] is bent, replace the steering stem.

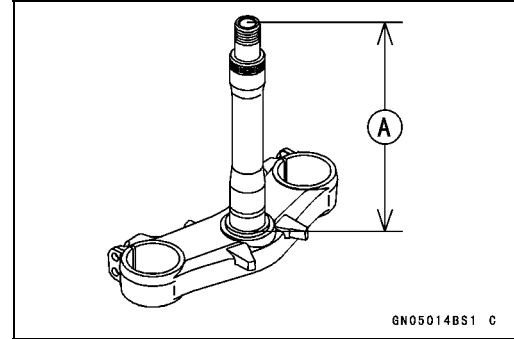

#### *Stem Cap Deterioration, Damage*

- ★ Replace the stem cap if its grease seal [A] shows damage.





## Handlebar

### Handlebar Removal

- Remove:
  - Clutch Lever Clamp Bolts [A]
  - Clutch Lever Assembly [B]
  - Left Handlebar Switch Housing [C]
  - Handlebar Weight [D]
  
- Remove:
  - Front Brake Reservoir Bracket Bolt [A]
  - Front Brake Master Cylinder [B]
  - Front Brake Light Switch Connector [C]
  - Right handlebar Switch Housing [D]
  - Throttle Case [E]
  - Handlebar Weight [F]
  - Throttle Grip [G]
  
- Loosen:
  - Front Fork Clamp Bolts [A]
  - Handlebar Bolts [B]
- Remove:
  - Steering Stem Head Nut [C]
  - Steering Stem Head [D] with Handlebars [E]
  
- Remove:
  - Handlebar Position Bolt [A]
- Remove the handlebars [B].
  - Left Handlebar Grip

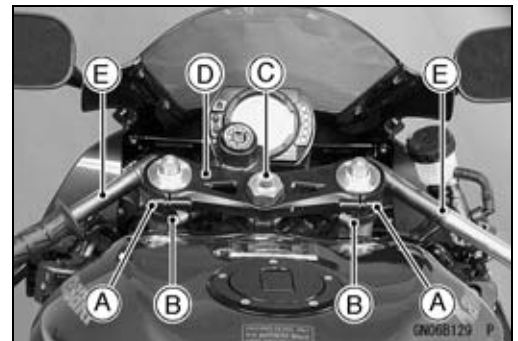
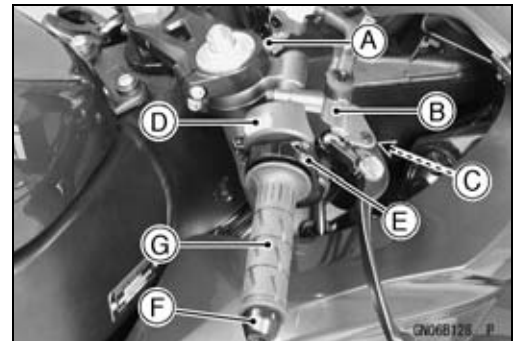
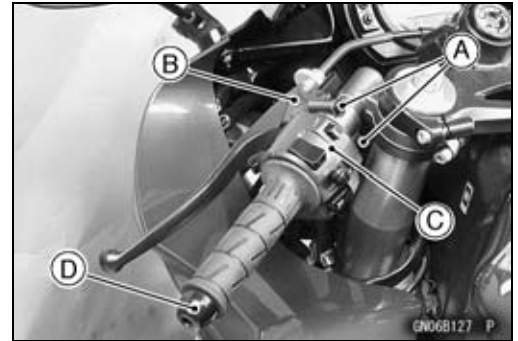

### Handlebar Installation

- Apply adhesive cement to the inside of the left handlebar grip.
- Apply a non-permanent locking agent:
  - Handlebar Position Bolts

**Torque - Handlebar Bolts: 25 N·m (2.5 kgf·m, 187 in·lb)**  
**Handlebar Position Bolts: 9.8 N·m (1.0 kgf·m, 87 in·lb)**
- Apply oil to the thread of handlebar weight screws.
  - Torque - Handlebar Weight Screws: 29 N·m (3.0 kgf·m, 22 ft·lb)**
- Install the front brake master cylinder (see Brakes chapter).

## 14-12 STEERING

### Handlebar

- Install the left and right handlebar switch housings.
- Fit the projection [A] into a small hole [B] in the handlebar.

**Torque - Handlebar Switch Housing Screws: 3.5 N·m (0.36 kgf·m, 31 in·lb)**

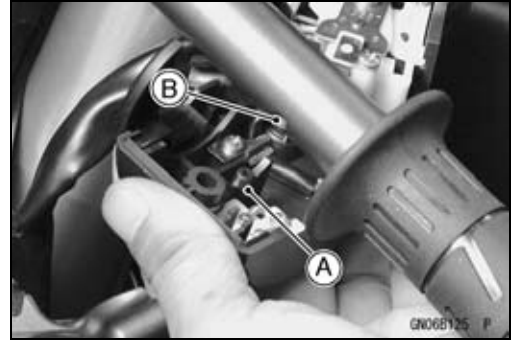

- Install the clutch lever [A] so that the mating surface [B] of the clutch lever clamps with punch mark [C] on the handlebar.

**Torque - Clutch Lever Clamp Bolts: 7.8 N·m (0.80 kgf·m, 69 in·lb)**

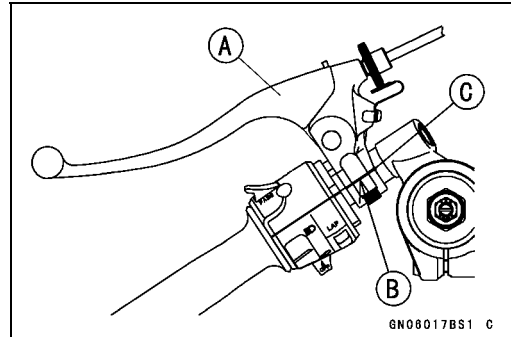

- Install:
  - Throttle Grip
  - Throttle Cable Tips [A]
  - Throttle Cases [B]
- Fit the projection [C] into a small hole [D] in the handlebar.

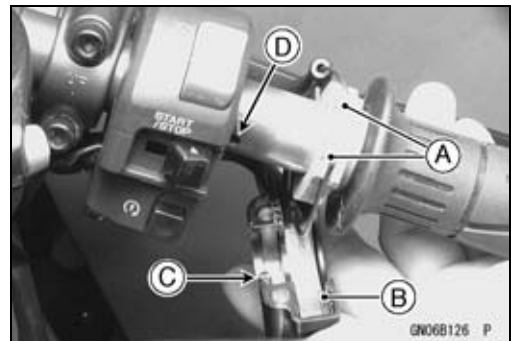

- Tighten:
  - Handlebar Weights
- Install the removed parts (see appropriate chapters).

# Frame

## Table of Contents

Exploded View .....	15-2
Seats .....	15-8
Rear Seat Removal.....	15-8
Rear Seat Installation.....	15-8
Front Seat Removal .....	15-8
Front Seat Installation .....	15-8
Fairings.....	15-10
Lower Fairing Removal .....	15-10
Lower Fairing Installation .....	15-10
Middle Fairing Removal .....	15-10
Middle Fairing Installation .....	15-11
Windshield Removal .....	15-11
Windshield Installation .....	15-11
Upper Fairing Removal .....	15-11
Upper Fairing Disassembly.....	15-12
Upper Fairing Assembly.....	15-13
Center Inner Fairing Removal.....	15-14
Center Inner Fairing Installation.....	15-14
Right and Left Inner Fairing Removal .....	15-14
Right and Left Inner Fairing Installation .....	15-15
Side Covers .....	15-16
Side Cover Removal .....	15-16
Side Cover Installation .....	15-16
Seat Cover.....	15-17
Seat Cover Removal.....	15-17
Seat Cover Installation.....	15-18
Fenders .....	15-19
Front Fender Removal .....	15-19
Front Fender Installation .....	15-19
Rear Fender Rear Removal.....	15-19
Rear Fender Rear Installation.....	15-20
Rear Fender Front Removal .....	15-20
Rear Fender Front Installation .....	15-21
Inner Fender Removal .....	15-21
Inner Fender Installation .....	15-21
Frame .....	15-22
Rear Frame Removal.....	15-22
Rear Frame Installation.....	15-22
Frame Inspection .....	15-22
Side Stand .....	15-23
Side Stand Removal .....	15-23
Side Stand Installation .....	15-23

# 15-2 FRAME

## Exploded View

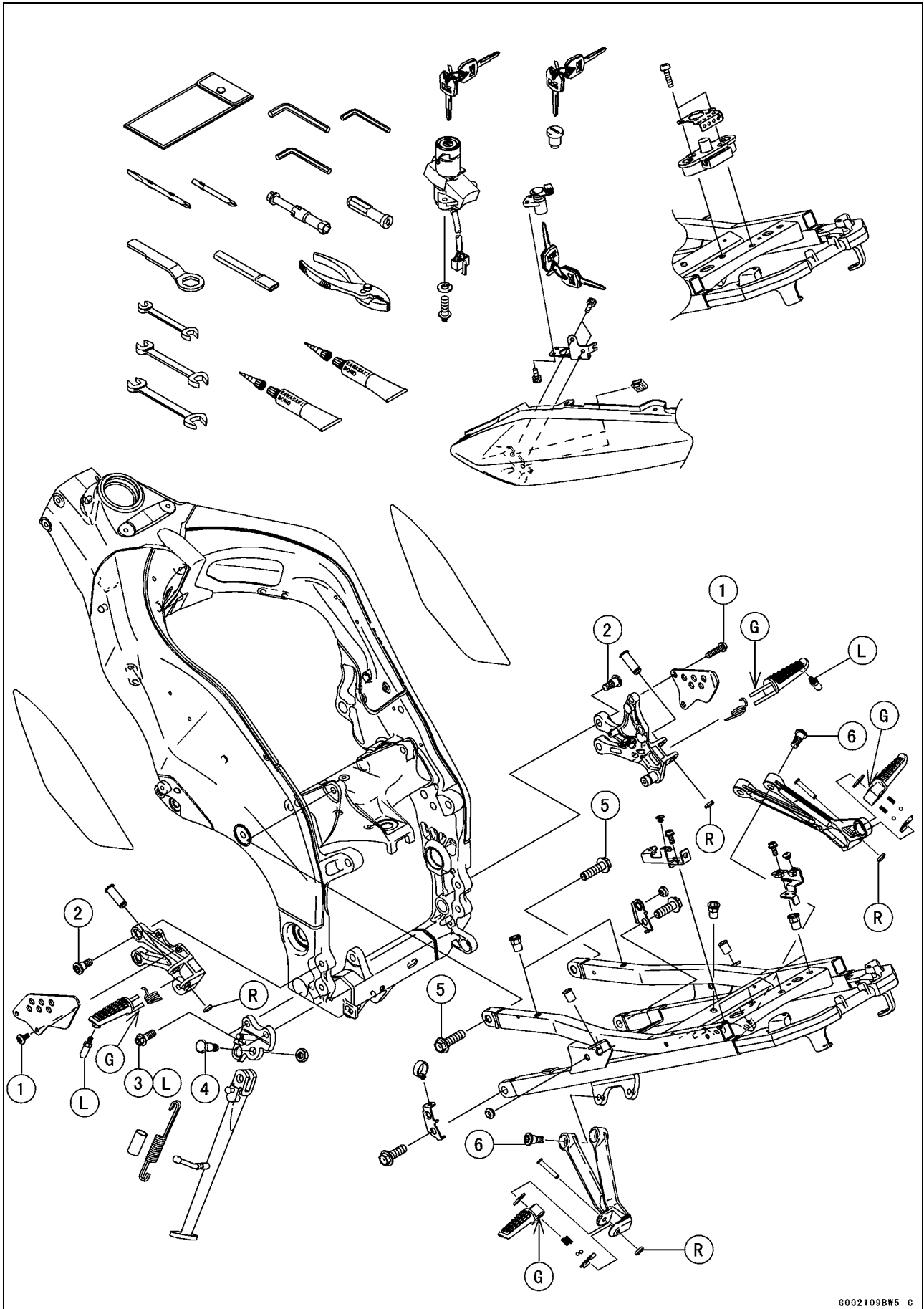

**Exploded View**

No.	Fastener	Torque			Remarks
		N·m	kgf·m	ft·lb	
1	Footguard Bolts	25	2.5	18	
2	Front Footpeg Stay Bolts	25	2.5	18	
3	Sidestand Bracket Bolts	49	5.0	36	L
4	Sidestand Bolt	44	4.5	32	G
5	Rear Frame Bolts	44	4.5	32	
6	Rear Footpeg Stay Bolts	25	2.5	18	

G: Apply grease.

L: Apply a non-permanent locking agent.

R: Replacement Parts

# 15-4 FRAME

## Exploded View

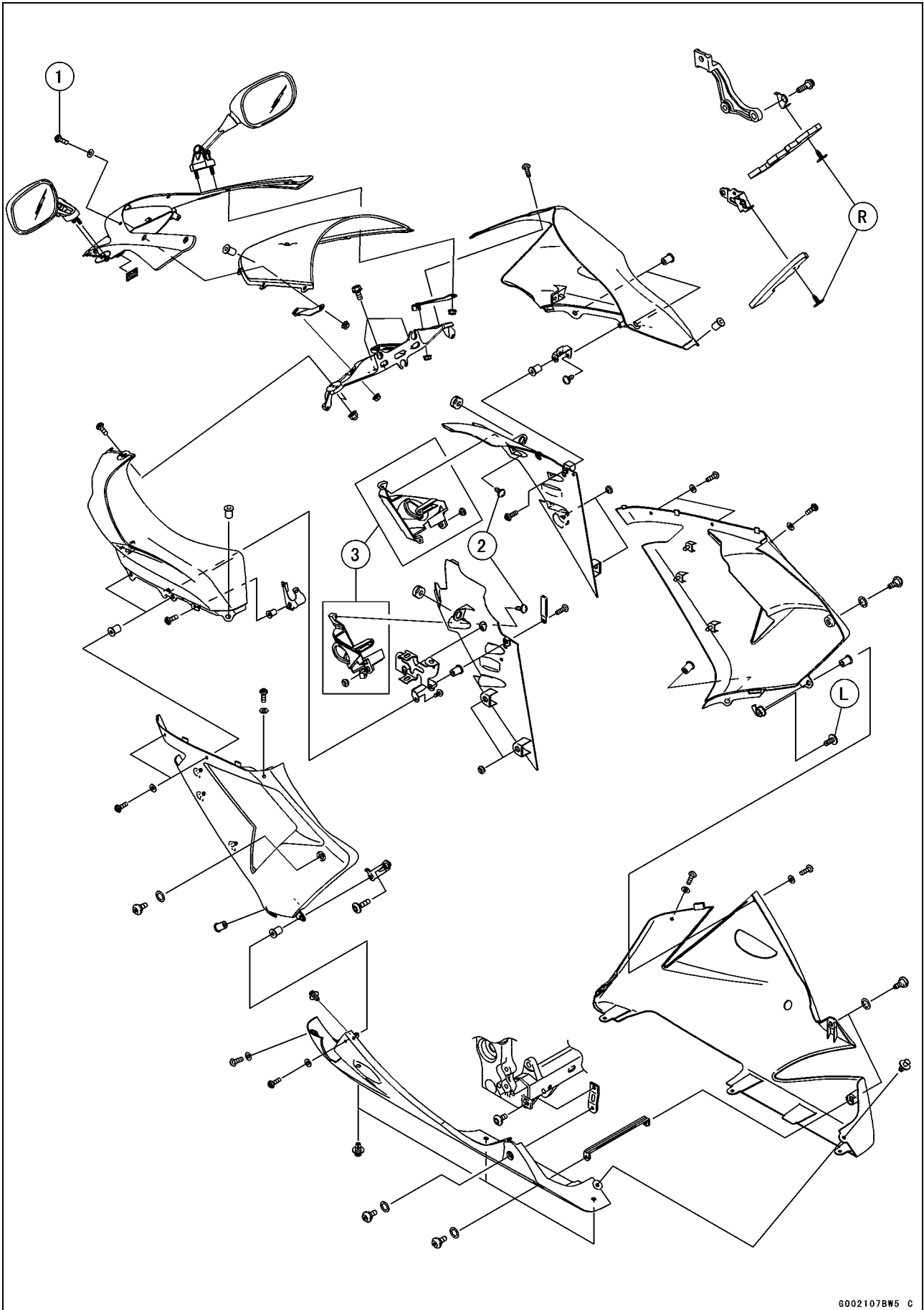

**Exploded View**

No.	Fastener	Torque			Remarks
		N·m	kgf·m	ft·lb	
1	Wind Shield Mounting Screws	0.4	0.04	3.5 in·lb	
2	Front Fender Mounting Bolts	3.9	0.40	35 in·lb	

- 3. United States and Canada Models
- L: Apply a non-permanent locking agent.
- R: Replacement Parts

# 15-6 FRAME

## Exploded View

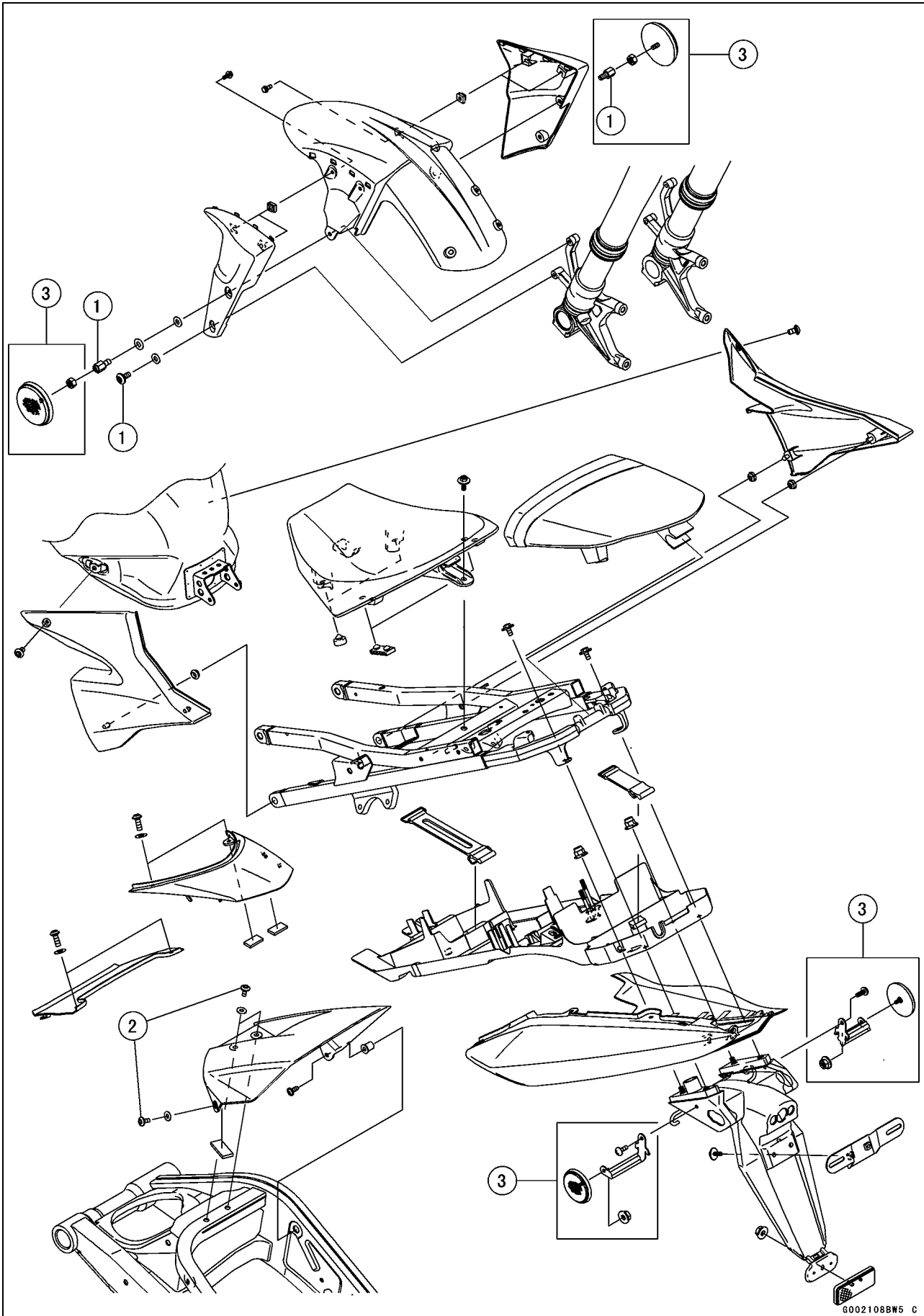



**Exploded View**

No.	Fastener	Torque			Remarks
		N·m	kgf·m	ft·lb	
1	Front Fender Mounting Bolts	3.9	0.40	35 in·lb	
2	Inner Fender Mounting Bolts	2.5	0.25	1.8 in·lb	

3. United States and Canada Models

## 15-8 FRAME

### Seats

#### Rear Seat Removal

- Insert the ignition switch key [A] into the seat lock, turning the key counterclockwise, pulling the front part of the seat [B] up, and pull the seat forward.

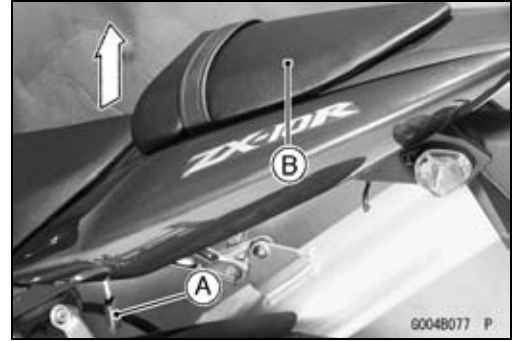

#### Rear Seat Installation

- Put the rear seat hook [A] on the rib [B].
- Insert the seat pins [C] into the latch holes [D].

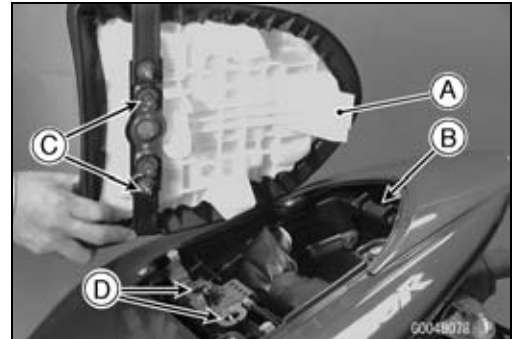

#### Front Seat Removal

- Remove:
  - Rear Seat (see Rear Seat Removal)
  - Bolts [A]
  - Upper Seat Cover [B]

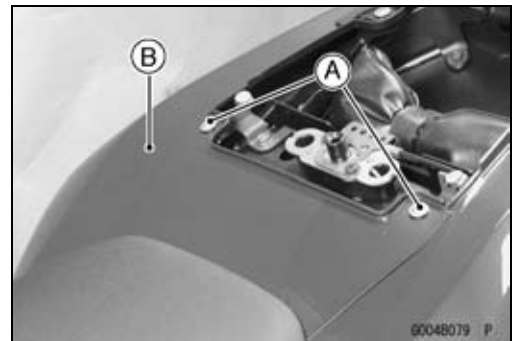

- Remove:
  - Mounting Bolt [A]
- Remove the front seat [B] by pulling the rear of it up and backward.

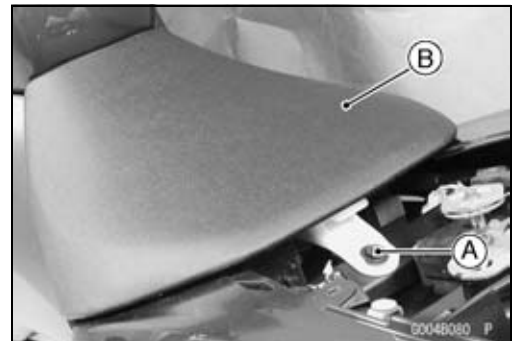

#### Front Seat Installation

- Slip the front seat hook [A] under the brace [B] of the fuel tank bracket.

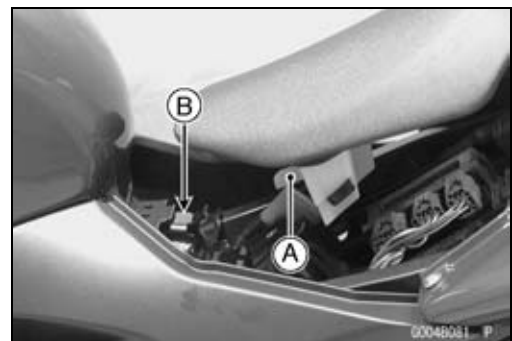

---

**Seats**

---

- Insert the tongues [A] of the upper seat cover into the holes [B] of the seat cover.

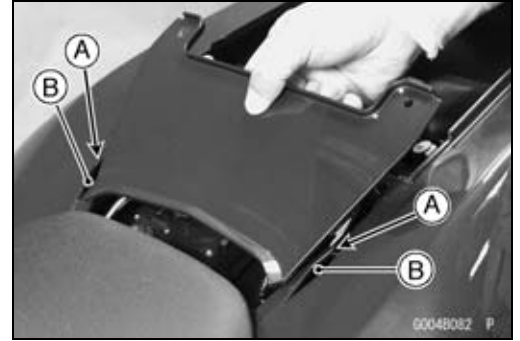

## 15-10 FRAME

### Fairings

#### Lower Fairing Removal

- Pull up the core [A] by the thin blade driver [B].

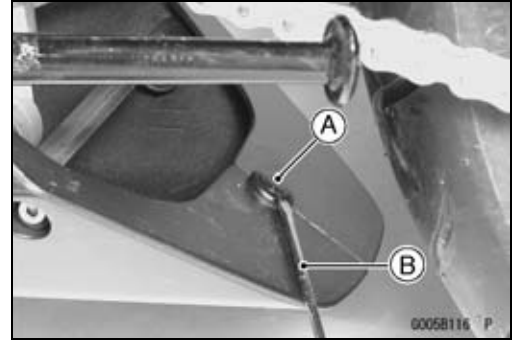

- Remove:
  - Quick Rivets [A]
  - Bolts [B] with Washers
- Clear the hook portion [C] from the slot.
- Separate the right lower fairing [D] from the left lower fairing.
- Remove the left lower fairing.

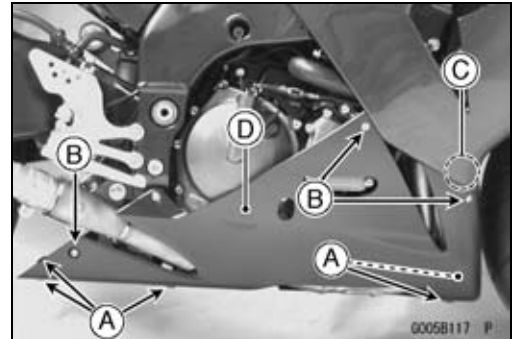

#### Lower Fairing Installation

- Insert the hook portion [A] into the slot [B].

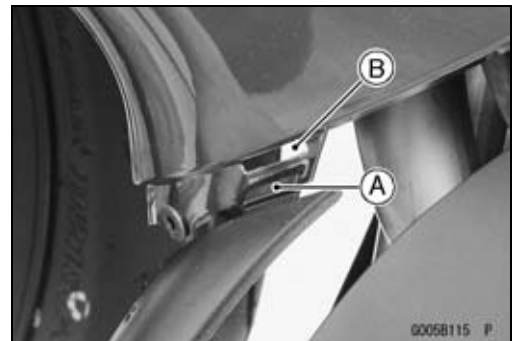

- Set the quick rivet [A] and push the core [B].

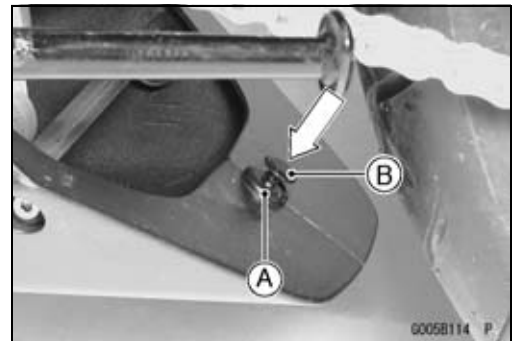

#### Middle Fairing Removal

- Remove:
  - Lower Fairings (see this chapter)
  - Bolts [A] with Washers
  - Right Middle Fairing [B]
- Pull out the middle fairing to clear its projections [C] from the grommets of the inner fairing.

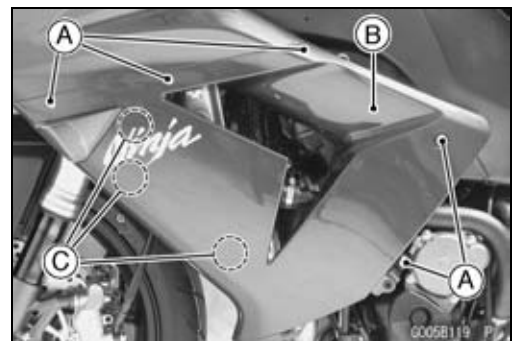

## Fairings

### Middle Fairing Installation

- Insert the hooks [A] into the slots [B] first.
- Next, fit the projections into the grommets.

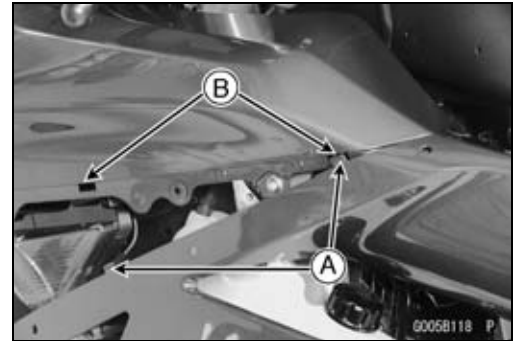

### Windshield Removal

- Remove:
  - Bolts [A]
  - Bolts and Nuts [B]
  - Windshield [C]

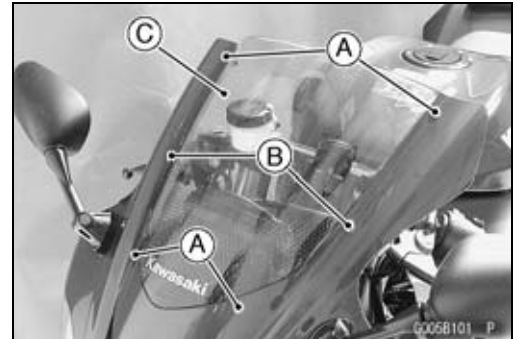

### Windshield Installation

- Put the front tongue [A] into the hollow [B] and insert both side tongues [C] between the upper fairing [D] and bracket [E].

**Torque - Windshield Bolts: 0.4 N·m (0.04 kgf·m, 4 in·lb)**

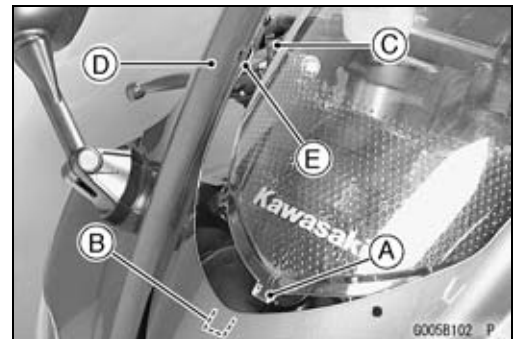

### Upper Fairing Removal

- Remove:
    - Lower Fairings (see this chapter)
    - Middle Fairings (see this chapter)
    - Windshield (see this chapter)
    - Bolts [A]
  - Disconnect the connectors [B].
  - Except the immobilizer models [C].
- Open the clamps [A] (Right and Left Side)

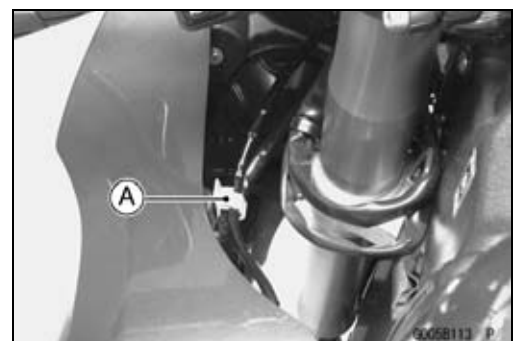
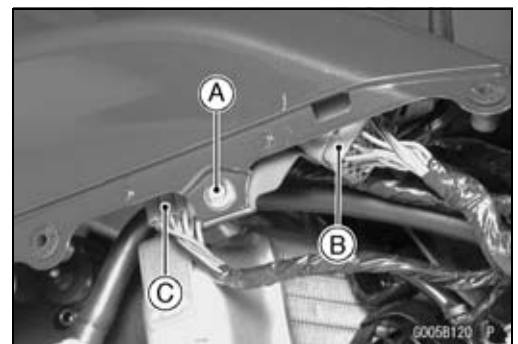

## 15-12 FRAME

### Fairings

- Remove:
  - Bolts [A]
- Pull out the upper fairing with inner fairings.



#### Upper Fairing Disassembly

- Remove:
  - Nuts [A] (Left and Right)
  - Rear View Mirrors [B] (Left and Right)
  - Upper Fairing Center [C]

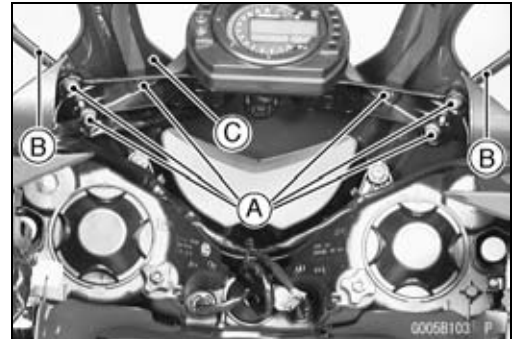

- Remove:
  - Screw [A]
  - Center Inner Fairing [B]
- Slide the center inner fairing towards [C].

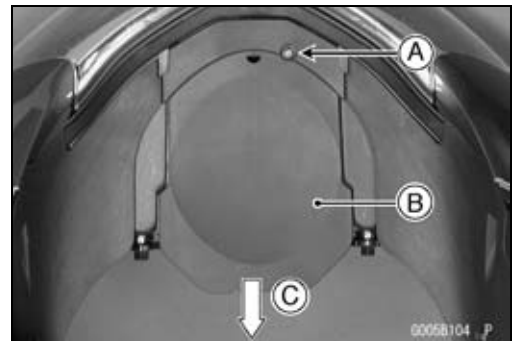

- Remove:
  - Screws [A]
  - Right and Left Inner Fairing [B]
- Pull out the grommet portion [C] from the collar [D].
- Disconnect the turn signal lead connectors [E].

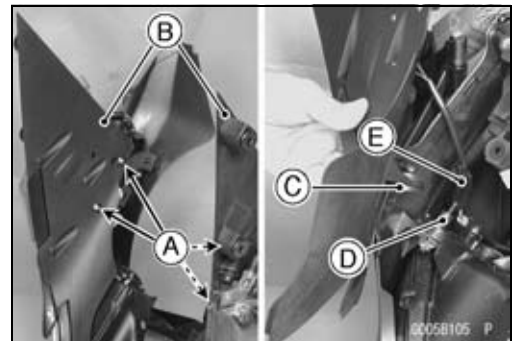

#### For the California Model

- Remove:
  - Hose (Green) [A]
  - Hose (Blue) [B]
  - Clamp (Open) [C]

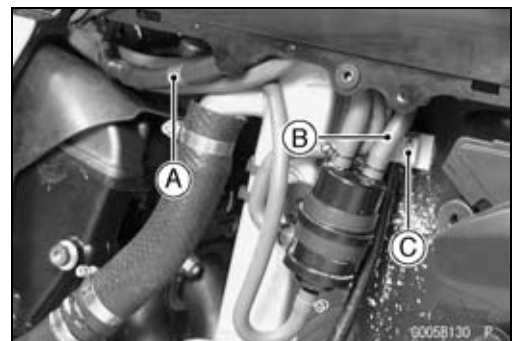

## Fairings

- Remove:  
Studs [A]

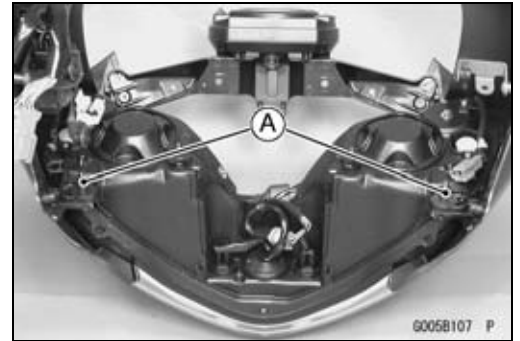

- Remove:  
Bolts [A]  
Right Upper Fairing [B]  
Left Upper Fairing [C]

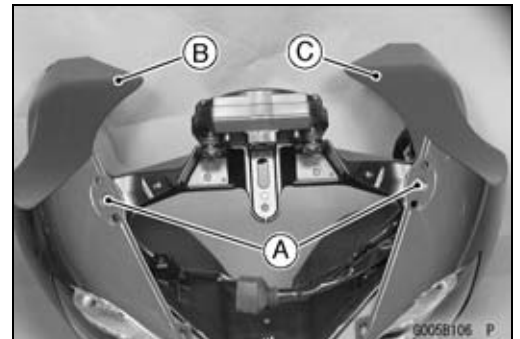

### For the Immobilizer Models

- Remove:  
Screw [A]  
Immobilizer Amplifier Bracket with Amplifier [B]

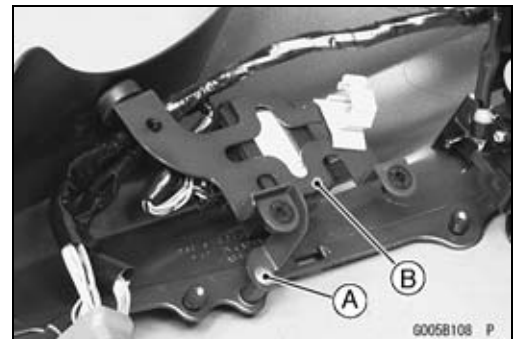

### For the California Model

- Remove:  
Screw [A]  
Canister [B] with Bracket [C]

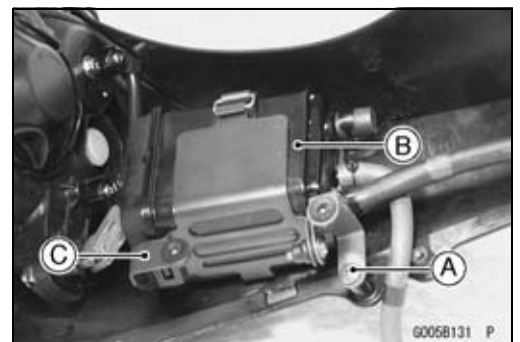

### Upper Fairing Assembly

- Fit the hole [A] of the upper fairing center onto the projection [B] of the headlight.
- Fit the connectors [C].

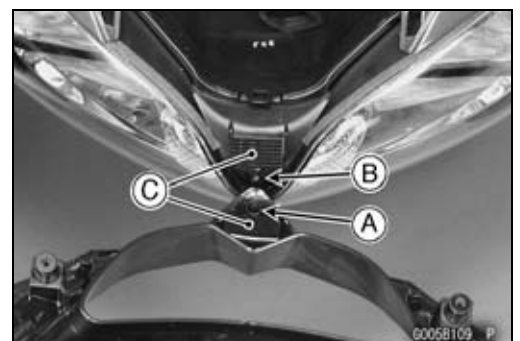

## 15-14 FRAME

### Fairings

- Fit the opening [A] of the upper fairing into the ram air duct [B].

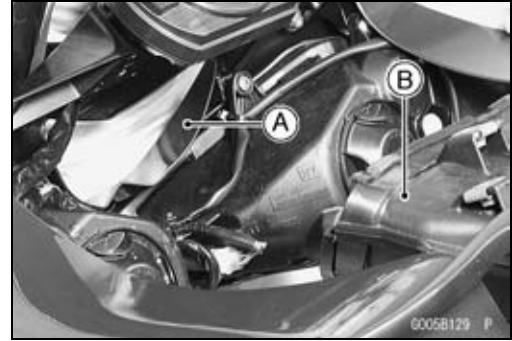

#### *Center Inner Fairing Removal*

- Remove:
  - Screw [A]
  - Center Inner Fairing [B]
- Slide out the inner fairing backward [C].

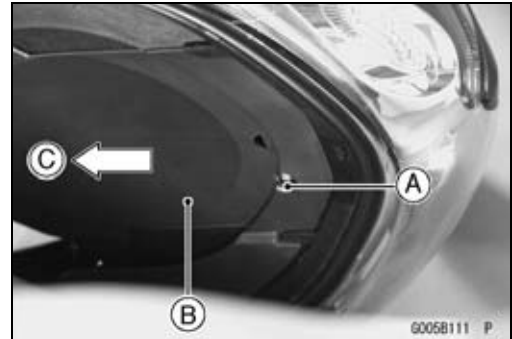

#### *Center Inner Fairing Installation*

- Insert the front portion [A], and tongues [B] of the center inner fairing into the grooves [C] of the headlight.

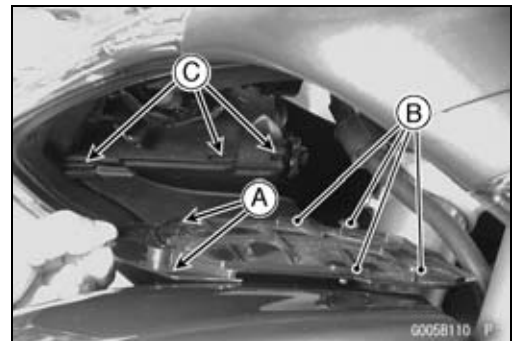

#### *Right and Left Inner Fairing Removal*

- Remove:
  - Right and Left Middle Fairings (see this chapter)
  - Bolts [A]
  - Inner Fairing [B]
- Slide out the inner fairing backward [C].

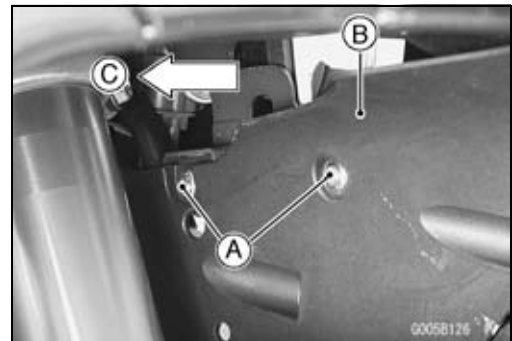

- Disconnect the turn signal lead connector [A].





## Fairings

### *Right and Left Inner Fairing Installation*

- Insert the grommet hole [A] into the stud [B] and insert the tongues [C] into the grooves [D].

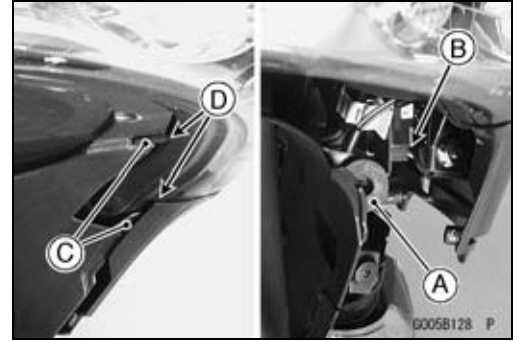

## 15-16 FRAME

### Side Covers

#### *Side Cover Removal*

- Remove:
  - Bolt [A]
- Pull out the side cover [B].

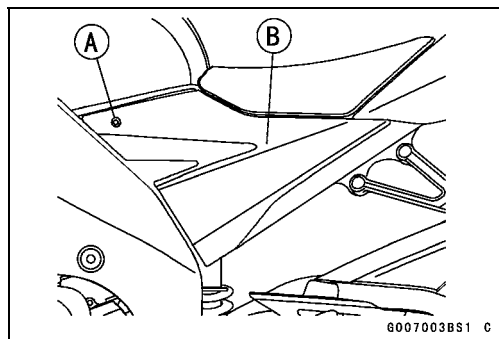

#### *Side Cover Installation*

- Insert the projections [A] into the holes [B].

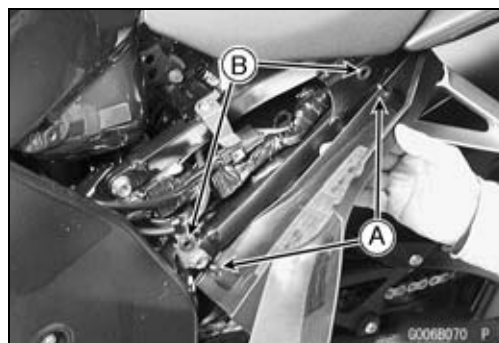

## Seat Cover

### Seat Cover Removal

- Remove:
  - Seats (see this chapter)
  - Bolts and Washers [A]
  - Tail/Brake Light Cover [B]
  
- Pull the dust cover [A].
- Disconnect:
  - Tail/Brake Light Connector [B]
  - Rear Turn Signal Lead Connectors [C]
  - Licence Plate Light Lead Connector [D]
  
- Remove:
  - Bolts [A]
  - Nuts [B]
  - Rear Fender Rear
  
- Remove:
  - Bolts [A]
  
- Remove:
  - Screws [A]
  - Seat Striker with Guard [B]
- Pull the seat cover backward.

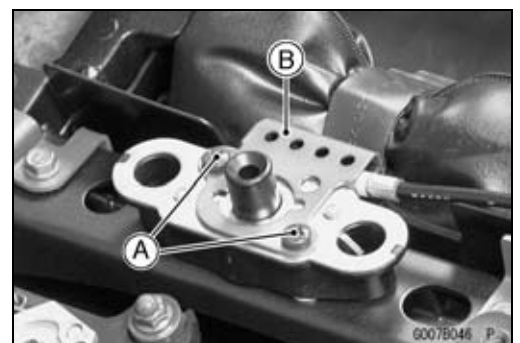
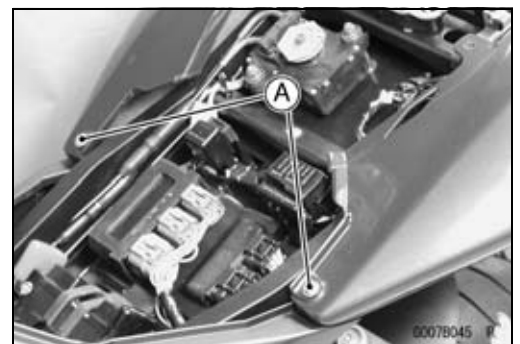
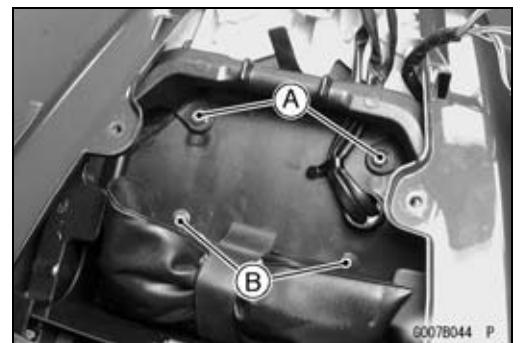
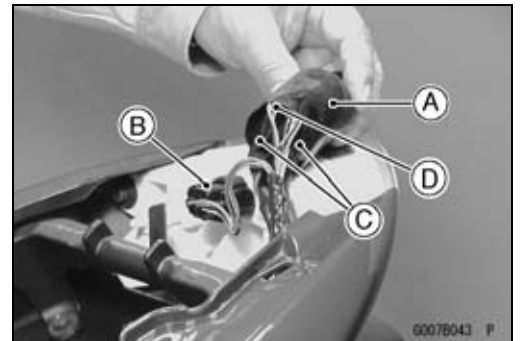
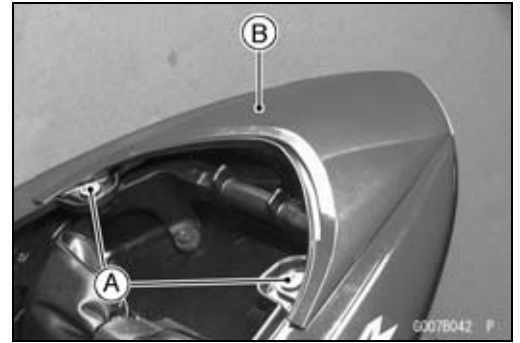

## 15-18 FRAME

### Seat Cover

- Remove:  
Bolts [A]  
Seat Lock Assy [B]

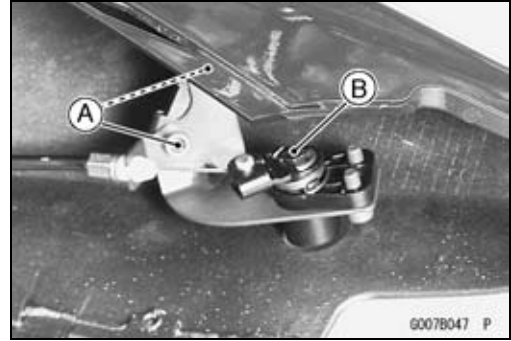

- Remove:  
Bolts [A]  
Tail/Brake Light [B]

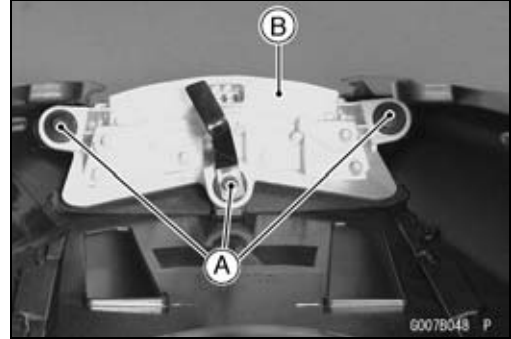

#### *Seat Cover Installation*

- Fit the projection [A] on the tail/brake light cover into the slot [B] of the seat cover.
- Fit the connectors [C].
- Install the seats (see this chapter).

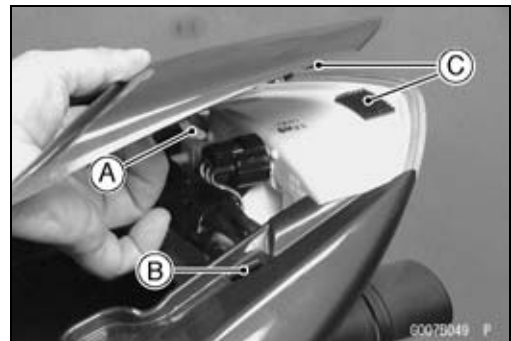

## Fenders

### Front Fender Removal

- Remove:
  - Brake Hose Clamps [A] (Left and Right)
  - Bolts [B] with Washer (Left and Right)
- Remove the front fender assy [C].

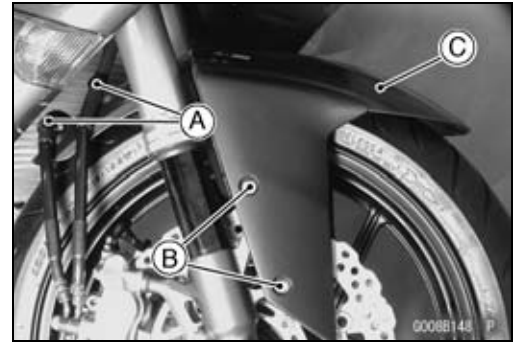

- Remove:
  - Bolts [A]
- Separate the front fender cover [B] and front fender [C].

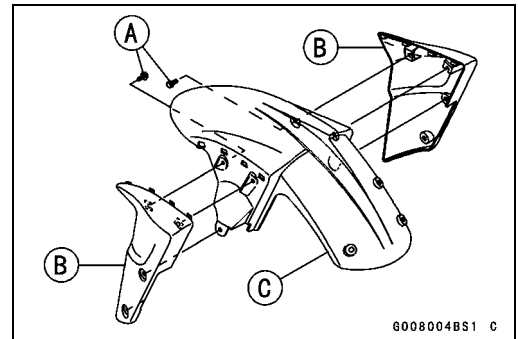

### Front Fender Installation

- Install the front fender to the front fork.
- Tighten:
  - Torque - Front Fender Mounting Bolts: 3.9 N·m (0.40 kgf·m, 35 in·lb)**
- Install the brake hose clamps to the front fender holes.

### Rear Fender Rear Removal

- Remove:
  - Seats (see Rear/Front Seat Removal)
  - Tail/Brake Light Cover (see Seat Cover Removal)
  - Dust Cover [A]
- Disconnect:
  - Rear Turn Signal Light Lead Connectors [B] (Left and Right)
  - License Light Lead Connector [C]

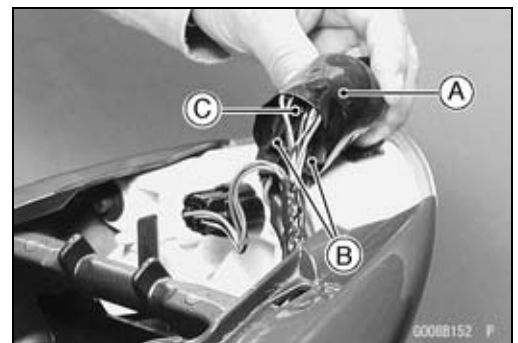

- Remove:
  - Clamp [A] (cut)
  - Bolts [B]
  - Nuts [C]

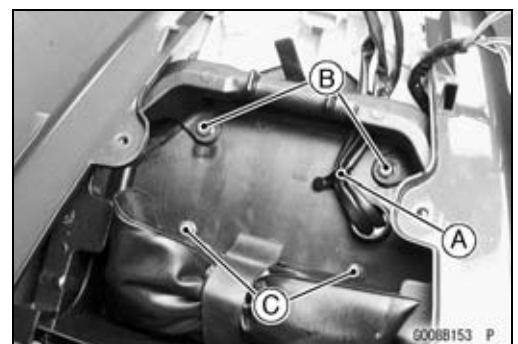

## 15-20 FRAME

### Fenders

- Pull out the rear fender rear [A] assembled turn signal lights and license plate light downward.

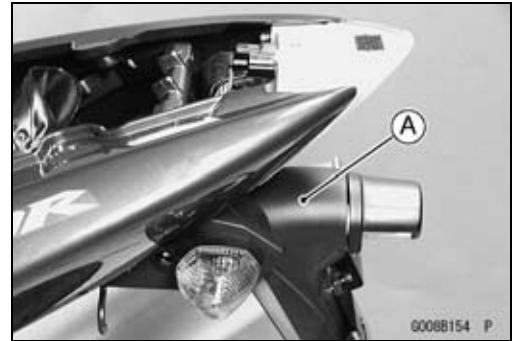

#### *Rear Fender Rear Installation*

- Install the harness clamp in accordance with Harness Routing section in Appendix chapter.

#### *Rear Fender Front Removal*

- Remove:
  - Seat Cover (see this chapter)
  - Battery [A] (see Electrical System chapter)
  - Fuse Box [B] (see Electrical System chapter)
  - Starter Relay Assy [C] (see Electrical System chapter)
  - ECU with Relay Box [D] (see Electrical System chapter)
  - Turn Signal Relay [E] (see Electrical System chapter)
  - Fuel Pump Relay [F] (see Fuel System (DFI) chapter)
  - Exhaust Butterfly Valve Actuator [G] with cables (see Engine Top End chapter)
  - Owner's Tool [H]
  - Atmospheric Pressure Sensor [I] (see Fuel System (DFI) chapter)
- Remove:
  - Rear Brake Fluid Reservoir Tank Bracket Bolt [A]

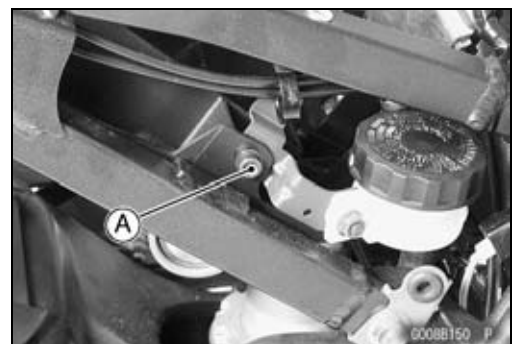
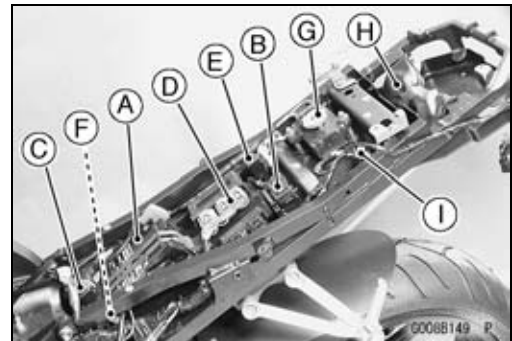

- Remove the bolt [A].
- Pull out the rear fender front backward.



## Fenders

### *Rear Fender Front Installation*

- Insert the hooks [A] of the rear fender front into the slots [B] of the rear frame.
- Install the removed parts.
- Run the harness correctly (see Appendix chapter).

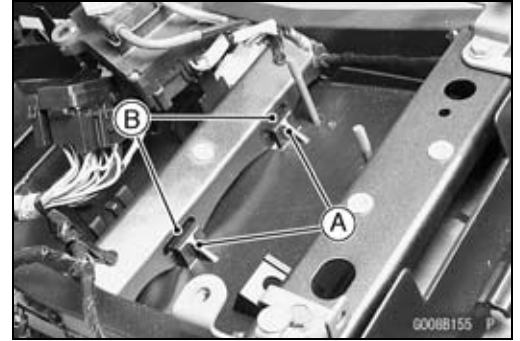

### *Inner Fender Removal*

- Remove:
  - Rear Wheel (see Tires/Wheels chapter)
  - Bolts [A]
  - Brake Hose Clamp [B]
  - Inner Rear Fender [C]

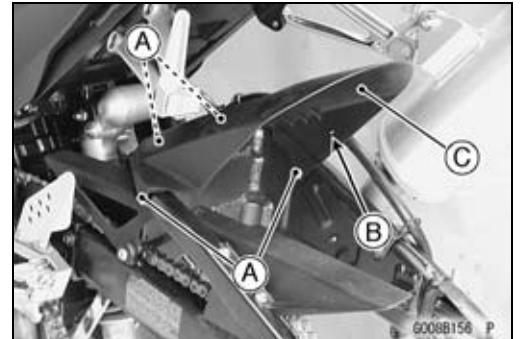

### *Inner Fender Installation*

- Tighten the bolts.
  - Torque - Inner Fender Bolts: 2.5 N·m (0.25 kgf·m, 1.8 in·lb)**
- Insert the brake hose clamp to the inner fender hole.

## 15-22 FRAME

### Frame

#### *Rear Frame Removal*

- Remove:
  - Fuel Tank (see Fuel System (DFI) chapter)
  - Seat Cover (see Seat Cover Removal)
  - Rear Fender Front (see Rear Fender Front Removal)
  - Clamps for Main Harness
  - Frame Bolts and Nuts [A]
  - Rear Step Bracket Bolts [B]

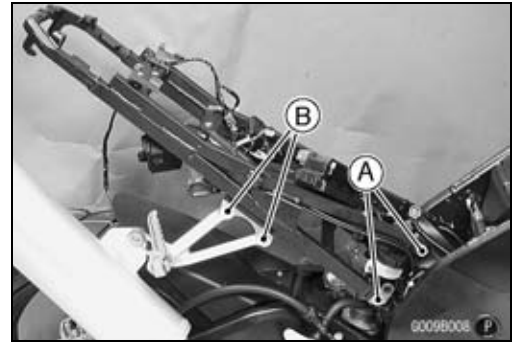

#### *Rear Frame Installation*

- Tighten:
  - Torque - Rear Frame Bolts and Nuts: 44 N·m (4.5 kgf·m, 43 ft·lb)
  - Rear Step Brackets Bolts: 25 N·m (2.5 kgf·m, 19 ft·lb)

#### *Frame Inspection*

- Visually inspect the frame for cracks, dents, bending, or warp.
- ★ If there is any damage to the frame, replace it.

### **⚠ WARNING**

**A repaired frame may fail in use, possibly causing an accident. If the frame is bent, dented, cracked, or warped, replace it.**

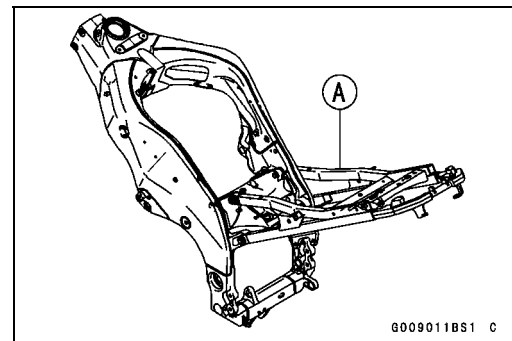



## Side Stand

### Side Stand Removal

- Raise the rear wheel off the ground with the stand.
- Remove:
  - Left Lower Fairing (see this chapter)
- Disconnect the side stand switch lead connector [A].

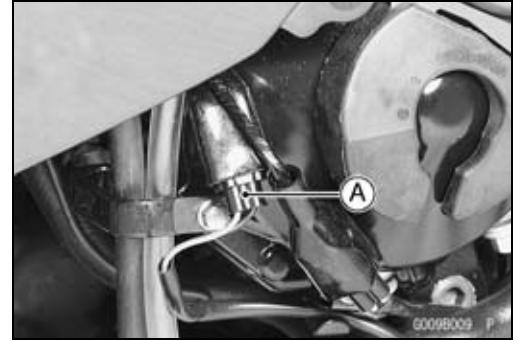

- Remove:
  - Side Stand Switch Bolt [A]
  - Spring [B]
  - Side Stand Bolt [C]
  - Side Stand [D]
  - Switch Bracket Bolts [E]
  - Side Stand Bracket Bolts [F]

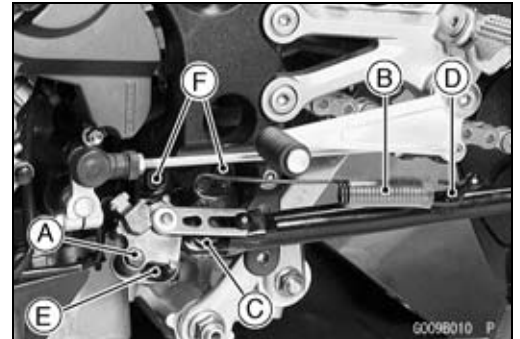

### Side Stand Installation

- Apply grease to the sliding area [A] of the side stand [B] and thread of the side stand bolt [C].
- Tighten the bolt and lock them with the nut.

**Torque - Side Stand Bracket Bolts [D]: 49 N·m (5.0 kgf·m, 36 ft·lb)**

**Side Stand Bolt: 44 N·m (4.5 kgf·m, 32 ft·lb)**

- Hook the spring [E] so that face the long spring end upward.
- Install the spring hook direction as shown.
- Install the switch bracket and side stand switch.
- Apply a non-permanent locking agent to the thread of the switch bolt.

**Torque - Side Stand Switch Bolt [F]: 8.8 N·m (0.90 kgf·m, 78 in·lb)**

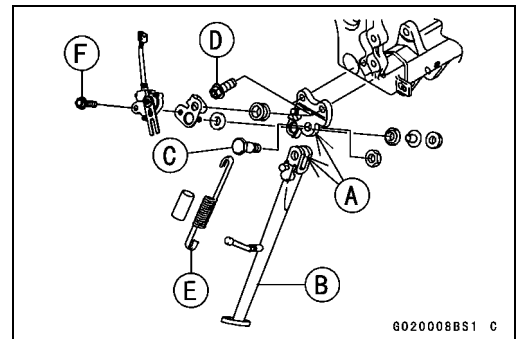



# Electrical System

## Table of Contents

Parts Location.....	16-3	Stick Coil Primary Peak Voltage ..	16-40
Exploded View.....	16-4	Spark Plug Removal .....	16-41
Wiring Diagram (United States, Canada and Kuwait).....	16-10	Spark Plug Installation .....	16-41
Wiring Diagram (Other than United States, Canada and Kuwait).....	16-12	Spark Plug Condition Inspection..	16-41
Specifications .....	16-14	Camshaft Position Sensor Removal.....	16-42
Special Tools .....	16-15	Camshaft Position Sensor Installation.....	16-42
Precautions.....	16-16	Camshaft Position Sensor Inspection.....	16-42
Electrical Wiring.....	16-18	Camshaft Position Sensor Peak Voltage Inspection.....	16-43
Wiring Inspection .....	16-18	Interlock Operation Inspection .....	16-44
Battery .....	16-19	IC Igniter Inspection .....	16-45
Battery Removal .....	16-19	Electric Starter System.....	16-46
Battery Installation .....	16-19	Starter Idle Gear Removal .....	16-46
Battery Activation.....	16-20	Starter Idle Gear Installation .....	16-46
Precautions.....	16-22	Starter Clutch Removal.....	16-46
Interchange.....	16-23	Starter Clutch Installation .....	16-47
Charging Condition Inspection.....	16-23	Starter Clutch Disassembly.....	16-47
Refreshing Charge.....	16-23	Starter Clutch Assembly .....	16-48
Charging System.....	16-25	Starter Clutch Inspection.....	16-48
Alternator Cover Removal.....	16-25	Starter Motor Removal.....	16-48
Alternator Cover Installation.....	16-25	Starter Motor Installation.....	16-49
Stator Coil Removal .....	16-26	Starter Motor Disassembly.....	16-50
Stator Coil Installation .....	16-26	Starter Motor Assembly .....	16-50
Alternator Rotor Removal .....	16-26	Brush Inspection .....	16-52
Alternator Rotor Installation .....	16-28	Commutator Cleaning and Inspection.....	16-52
Alternator Lever Removal .....	16-30	Armature Inspection.....	16-52
Alternator Lever Installation .....	16-31	Brush Lead Inspection .....	16-53
Alternator Inspection .....	16-31	Right-hand End Cover Assembly Inspection.....	16-53
Regulator/rectifier Inspection .....	16-32	Starter Relay Inspection.....	16-53
Regulator/rectifier Inspection .....	16-33	Lighting System.....	16-55
Charging Voltage Inspection .....	16-33	Headlight Beam Horizontal Vertical Adjustment .....	16-55
Ignition System.....	16-35	Headlight Beam Vertical Adjustment .....	16-55
Crankshaft Sensor Removal.....	16-36	Headlight Bulb Replacement .....	16-55
Crankshaft Sensor Installation .....	16-37	City Light Bulb Replacement.....	16-56
Crankshaft Sensor Inspection.....	16-37	Headlight Removal/Installation .....	16-56
Crankshaft Sensor Peak Voltage .....	16-37	Tail/Brake Light (LED) Removal...	16-57
Timing Rotor Removal .....	16-38	Tail/Brake Light (LED) Installation	16-57
Timing Rotor Installation .....	16-38	License Plate Light Bulb Replacement.....	16-57
Stick Coil (Ignition Coil together with Spark Plug Cap) Removal .....	16-38		
Stick Coil (Ignition Coil together with Spark Plug Cap) Installation.....	16-39		
Stick Coil (Ignition Coil together with Spark Plug Cap) Inspection	16-40		

## 16-2 ELECTRICAL SYSTEM

---

Turn Signal Light Bulb Replacement.....	16-59	Brake Light Timing Inspection.....	16-94
Turn Signal Relay Inspection .....	16-60	Brake Light Timing Adjustment ....	16-94
Air Switching Valve .....	16-62	Switch Inspection .....	16-94
Air Switching Valve Operation Test.....	16-62	Water Temperature Sensor Inspection.....	16-95
Air Switching Valve Unit Test .....	16-62	Speed Sensor Removal.....	16-95
Radiator Fan System.....	16-64	Speed Sensor Installation .....	16-95
Fan Motor Inspection .....	16-64	Speed Sensor Inspection.....	16-96
Meter, Gauge, Indicator Unit.....	16-65	Fuel Reserve Switch Inspection...	16-96
Meter Unit Removal .....	16-65	Gear Position Switch Removal ....	16-97
Meter Unit Disassembly .....	16-65	Gear Position Switch Installation .	16-97
Electronic Combination Meter Assembly Inspection .....	16-66	Gear Position Switch Inspection ..	16-98
Immobilizer System (Equipped Models) .....	16-74	Relay Box .....	16-99
Operational Cautions .....	16-74	Relay Box Removal .....	16-99
Key Registration.....	16-74	Relay Circuit Inspection .....	16-99
Immobilizer System Parts Replacement.....	16-90	Diode Circuit Inspection.....	16-100
Immobilizer System Inspection ....	16-92	Fuse.....	16-102
Switches and Sensors .....	16-94	30 A Main Fuse Removal.....	16-102
		Fuse Box Fuse Removal.....	16-102
		15 A ECU Fuse Removal.....	16-102
		Fuse Installation.....	16-103
		Fuse Inspection.....	16-103

Parts Location

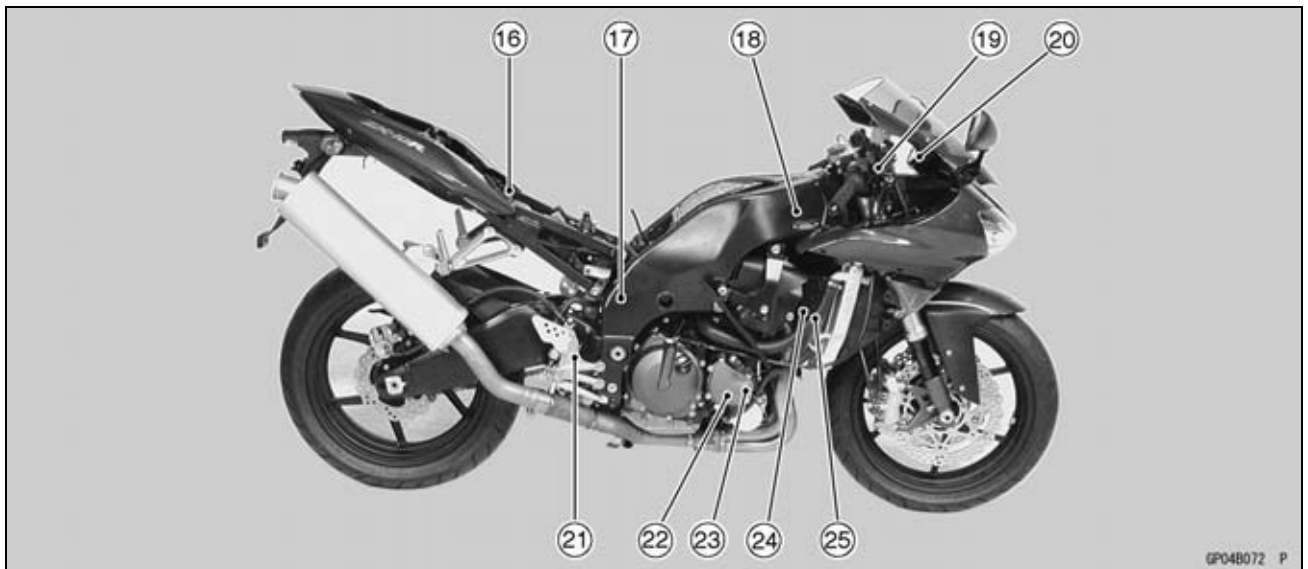
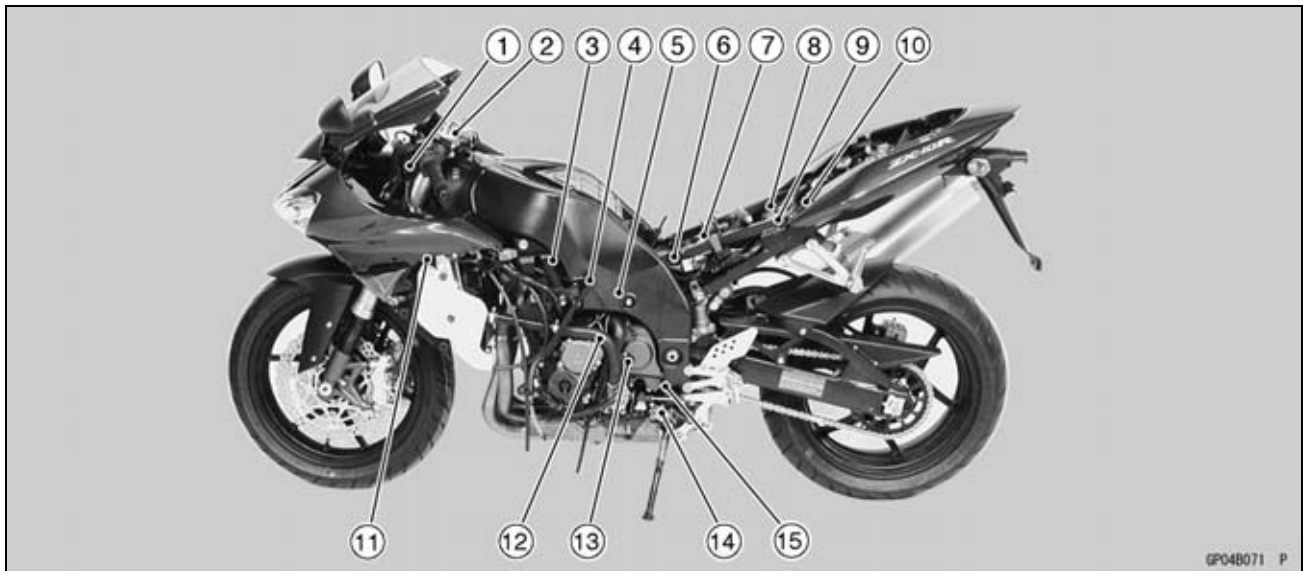

- |   |                              |
|---|------------------------------|
| 1. Starter Lockout Switch                   | 14. Sidestand Switch         |
| 2. Ignition Switch with Immobilizer Antenna | 15. Gear Position Switch     |
| 3. Stick Coils                              | 16. Turn Signal Relay        |
| 4. Water Temperature Sensor                 | 17. Regulator/rectifier      |
| 5. Alternator                               | 18. Air Switching Valve      |
| 6. Starter Relay with Main Fuse             | 19. Front Brake Light Switch |
| 7. Battery 12 V 10 Ah                       | 20. Meter                    |
| 8. Relay Box                                | 21. Rear Brake Light Switch  |
| 9. ECU (Electric Control Unit)              | 22. Timing Rotor             |
| 10. Fuse Box with ECU Main Fuse             | 23. Crankshaft Sensor        |
| 11. Immobilizer Amplifier                   | 24. Camshaft Position Sensor |
| 12. Starter Motor                           | 25. Fan Motor                |
| 13. Speed Sensor                            |                              |



## Exploded View

No.	Fastener	Torque			Remarks
		N·m	kgf·m	ft·lb	
1	Meter Mounting Screws	1.2	0.12	11 in·lb	
2	Headlight Mounting Screws	1.2	0.12	11 in·lb	
3	Front Brake Light Switch Screws	1.2	0.12	11 in·lb	
4	Switch Housing Screws	3.5	0.36	31 in·lb	
5	Front Turn Signal Light Mounting Screws	1.2	0.12	11 in·lb	
6	License Plate Light Mounting Screws	1.2	0.12	11 in·lb	

- 7. Other than U.S. and Canada Models
  - 8. Immobilizer Models
  - 9. Immobilizer Antenna
  - 10. Immobilizer Amplifier
- L: Apply a non-permanent locking agent.

# 16-6 ELECTRICAL SYSTEM

## Exploded View

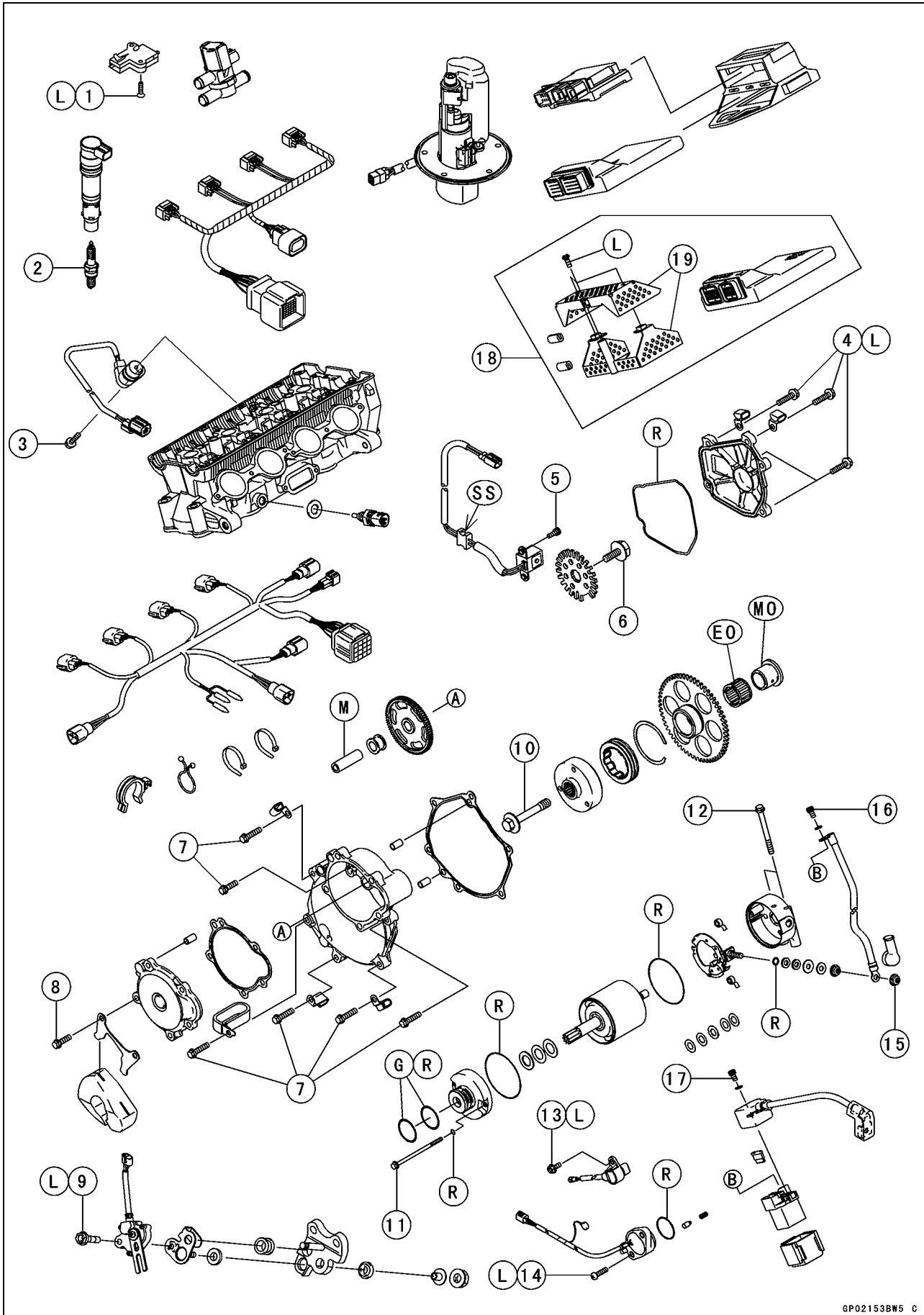



## Exploded View

No.	Fastener	Torque			Remarks
		N·m	kgf·m	ft·lb	
1	Starter Lockout Switch Screws	–	–	–	L
2	Spark Plugs	13	1.3	113 in·lb	
3	Camshaft Position Sensor Bolt	9.8	1.0	87 in·lb	
4	Crankshaft Sensor Cover Bolts	9.8	1.0	87 in·lb	L
5	Crankshaft Sensor Bolts	6.0	0.61	53 in·lb	
6	Timing Rotor Bolt	40	4.0	29	
7	Starter Clutch Cover Bolts	9.8	1.0	87 in·lb	
8	Idle Gear Cover Bolts	9.8	1.0	87 in·lb	
9	Side Stand Switch Bolt	8.8	0.80	78 in·lb	L
10	Starter Clutch Bolt	50	5.0	36	Lh
11	Starter Motor Though Bolts	3.5	0.36	31 in·lb	
12	Starter Motor Mounting Bolts	9.8	1.0	87 in·lb	
13	Speed Sensor Bolt	4.0	0.40	35 in·lb	L
14	Gear Position Switch Screws	4.9	0.50	43 in·lb	L
15	Starter Motor Lead Terminal Nut	6.0	0.61	53 in·lb	
16	Starter Motor Lead Mounting Bolt	4.0	0.41	35 in·lb	
17	Battery Lead Mounting Bolt	4.0	0.41	35 in·lb	

18. Immobilizer Models

19. Europe Model only

EO: Apply engine oil.

G: Apply grease.

L: Apply a non-permanent locking agent.

M: Apply molybdenum disulfide grease.

MO: Apply molybdenum disulfide oil (mixture of engine oil and molybdenum disulfide grease in a weight ratio is 10 : 1).

SS: Apply silicone sealant.

# 16-8 ELECTRICAL SYSTEM

## Exploded View

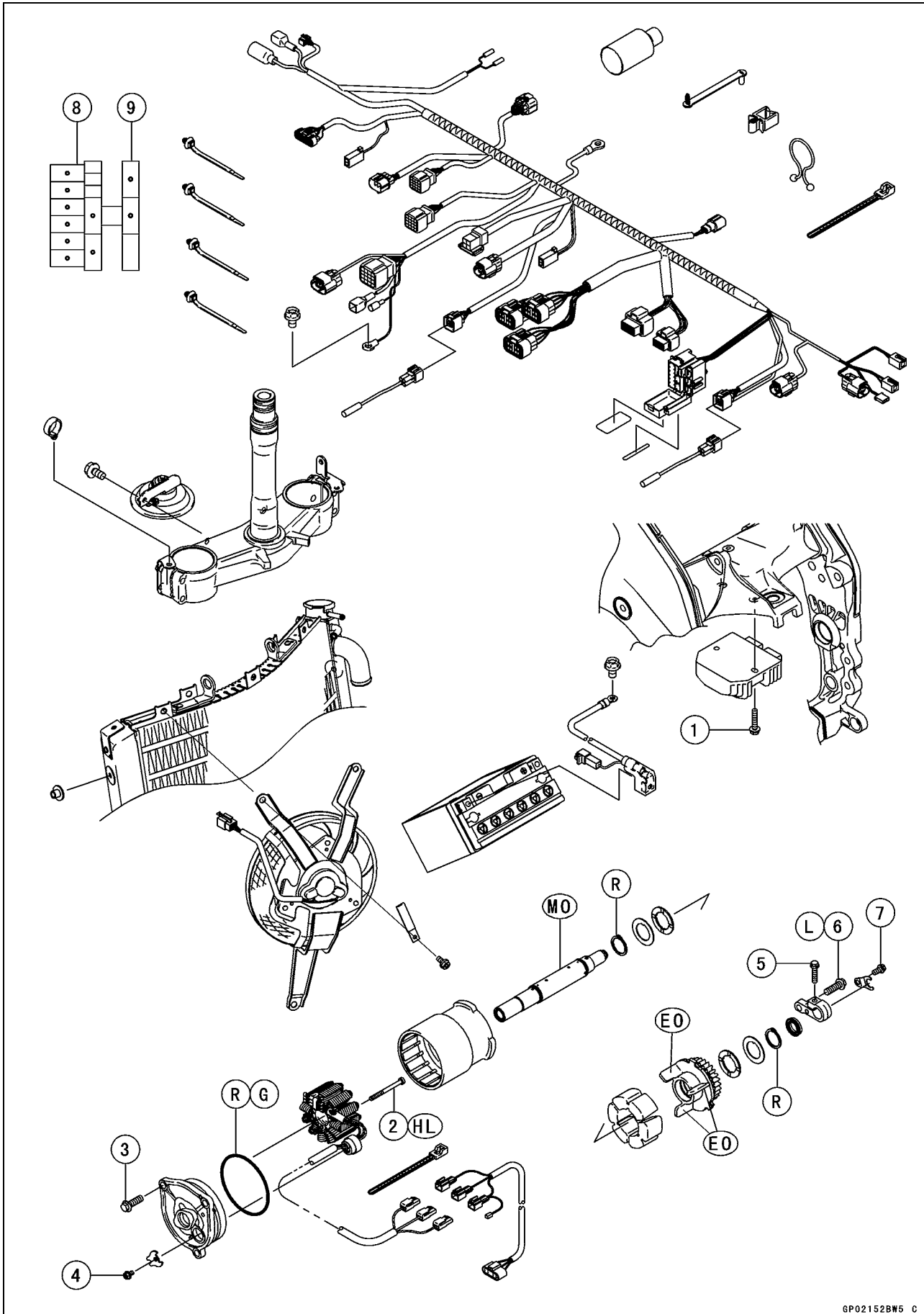

**Exploded View**

No.	Fastener	Torque			Remarks
		N·m	kgf·m	ft·lb	
1	Regulator/rectifier Bolts	9.8	1.0	87 in·lb	
2	Stator Coil Bolts	8.0	0.80	71 in·lb	HL
3	Alternator Cover Bolts	25	2.5	18	
4	Alternator Lead Holding Plate Bolt	6.0	0.61	53 in·lb	
5	Alternator Shaft Clamp Bolt	12	1.2	104 in·lb	
6	Alternator Shaft Lever Bolt	25	2.5	18	L
7	Alternator Shaft Spring Bolt	9.8	1.0	87 in·lb	

8. Fuse Box

9. ECU Main Fuse

EO: Apply engine oil.

G: Apply grease.

HL: Apply a heavy duty non-permanent locking agent (Three Bond 1360N).

L: Apply a non-permanent locking agent.

MO: Apply molybdenum disulfide oil (mixture of engine oil and molybdenum disulfide grease in a weight ratio is 10 : 1).

R: Replacement Parts

# 16-10 ELECTRICAL SYSTEM

## Wiring Diagram (United States, Canada and Kuwait)

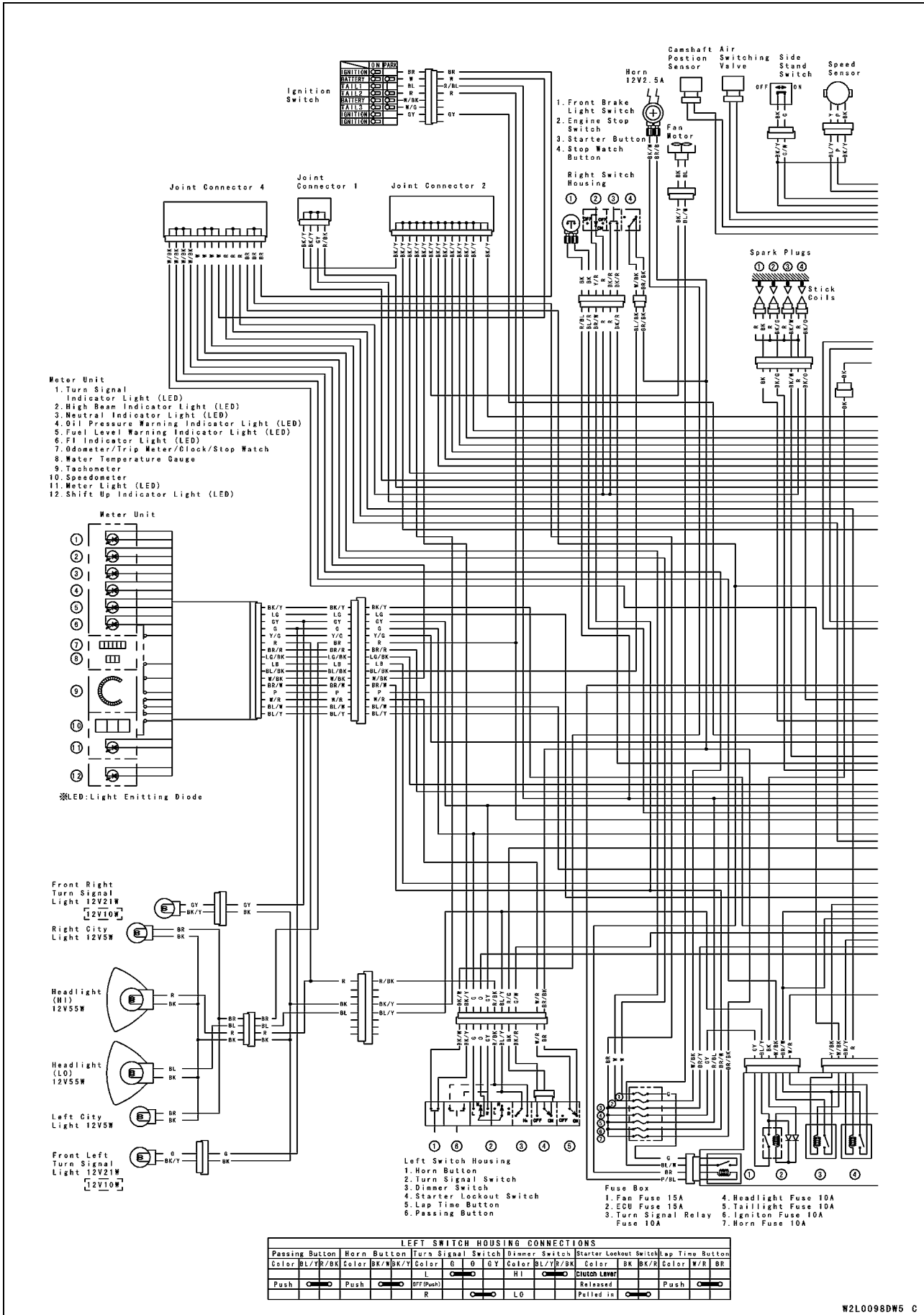

## Wiring Diagram (United States, Canada and Kuwait)

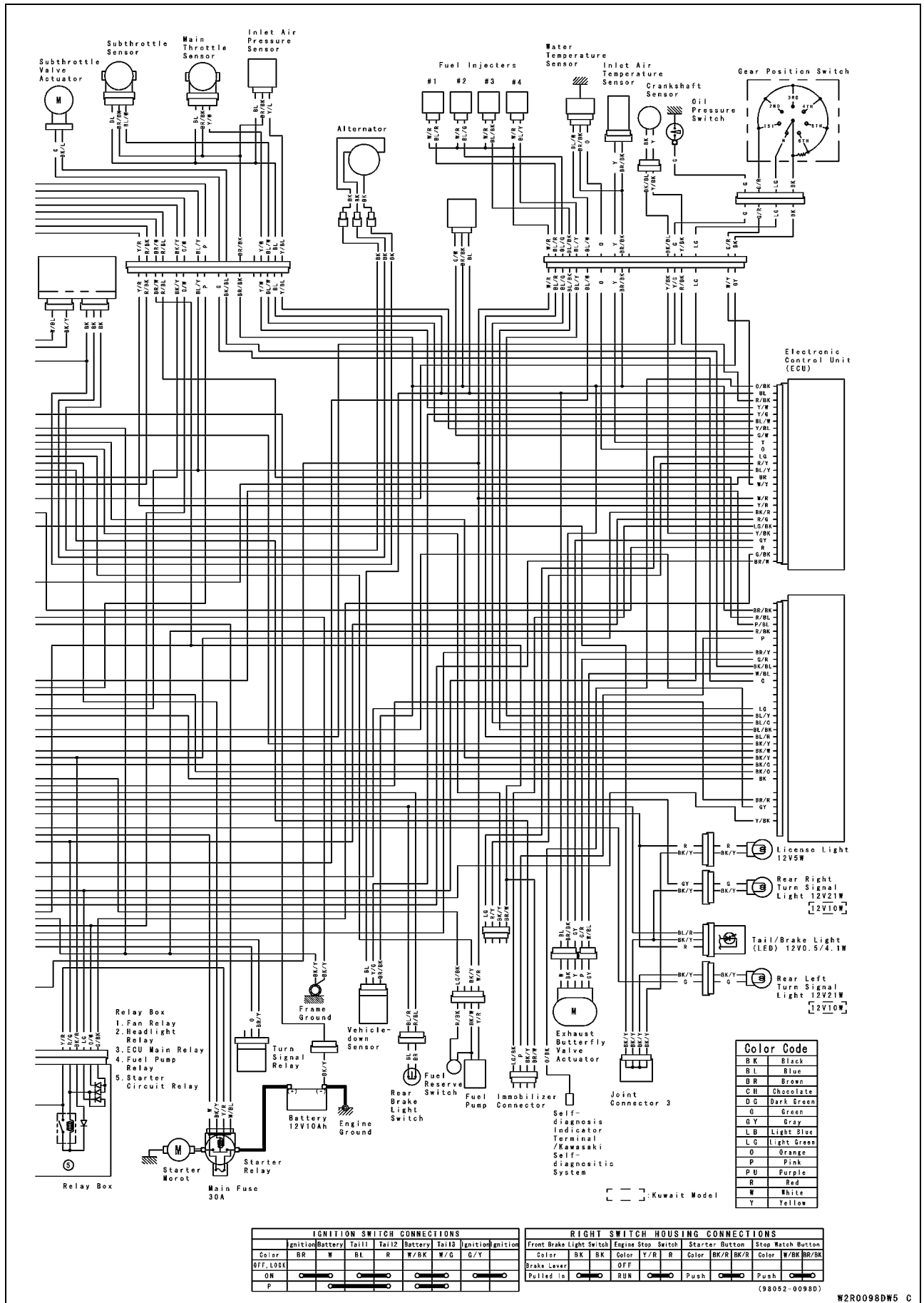



# ELECTRICAL SYSTEM 16-13

## Wiring Diagram (Other than United States, Canada and Kuwait)

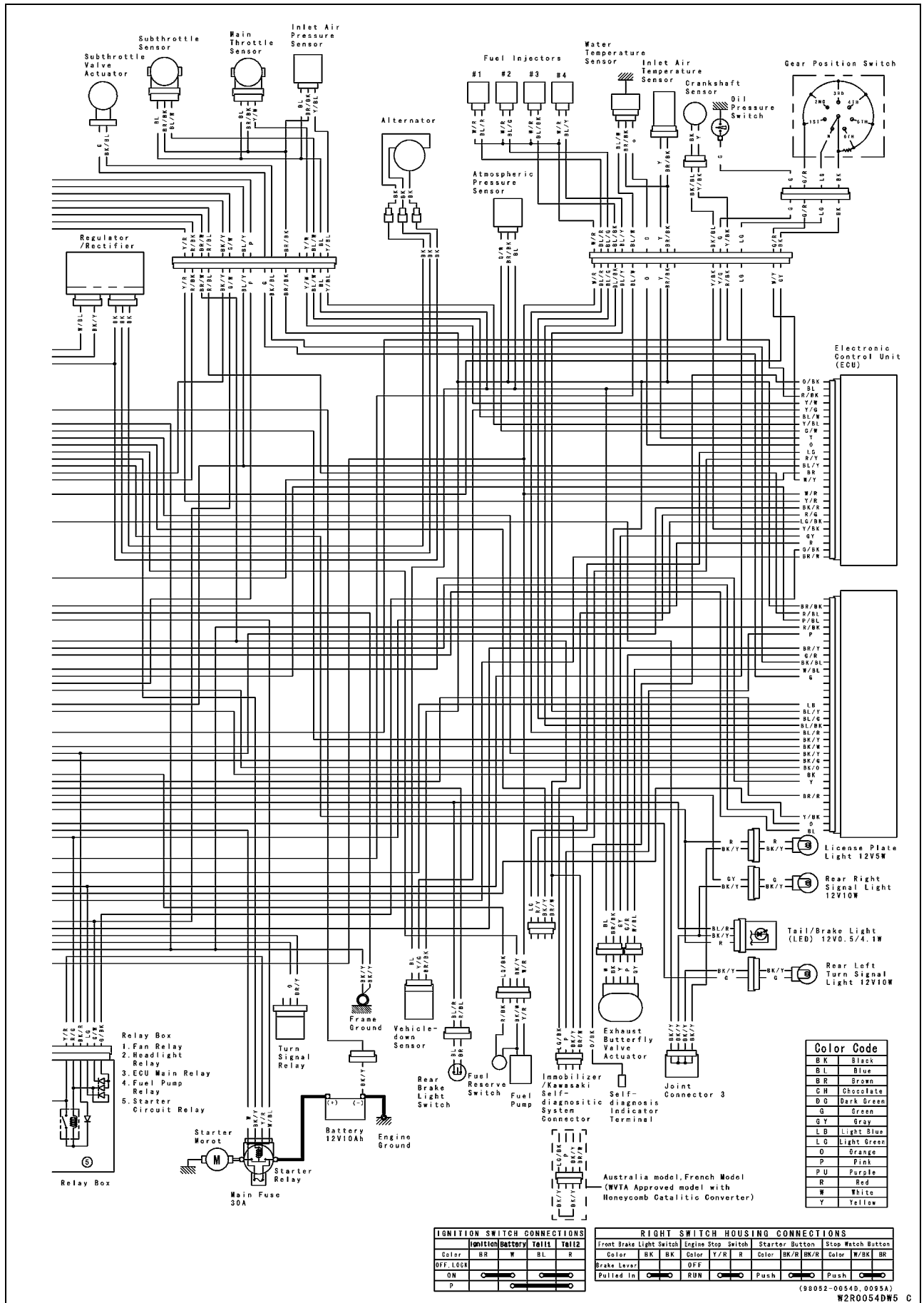

## 16-14 ELECTRICAL SYSTEM

### Specifications

Item	Standard
<b>Battery</b> Type Capacity Voltage	Sealed battery 12 V 10 Ah 12.6 V or more
<b>Charging System</b> Type Alternator Output Voltage Stator Coil Resistance Charging Voltage (Regulator/rectifier Output Voltage)	Three-phase AC 42 V or more @4 000 r/min (rpm) 0.05 ~ 0.5 $\Omega$ 14.2 ~ 15.2 V
<b>Ignition System</b> Crankshaft Sensor Resistance Crankshaft Sensor Peak Voltage Camshaft Position Sensor Resistance Camshaft Position Sensor Peak Voltage Spark Plug Gap Stick Coil: Primary Winding Resistance Secondary Winding Resistance Primary Peak Voltage	380 ~ 570 $\Omega$ 3.2 V or more 400 ~ 460 $\Omega$ 0.4 V or more 0.8 mm ~ 0.9 mm (0.032 ~ 0.035 in.) 1.2 ~ 1.6 $\Omega$ 8.5 ~ 11.5 k $\Omega$ 72 V or more
<b>Electric Starter System</b> Starter Motor: Brush Length Commutator Diameter	7 mm (0.28 in.), Service limit 3.5 mm (0.14 in.) 24 mm (0.94 in.), Service limit 23 mm (0.91 in.)
<b>Switch and Sensor</b> Rear Brake Light Switch Timing Engine Oil Pressure Switch Connections Fan Switch Resistance: Rising Temperature Falling Temperature Water Temperature Sensor Resistance	ON after about 10 mm (0.39 in.) pedal travel When engine is stopped: ON When engine is running: OFF From OFF to ON @93 ~ 103°C (199 ~ 217°F) Fan stops with the temperature 3 ~ 8°C (38 ~ 46°F) lower than the operation temperature range. ON: Less than 0.5 $\Omega$ OFF: More than 10 M $\Omega$ In the text



**Special Tools**

**Hand Tester:  
57001-1394**

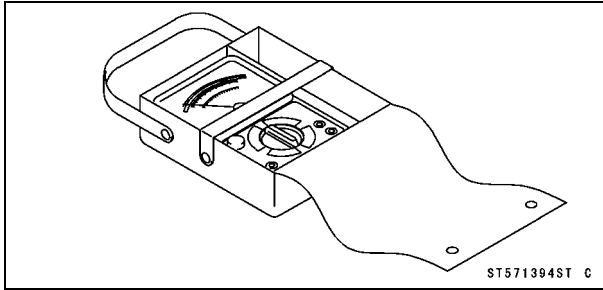

**Harness Adapter:  
57001-1542**

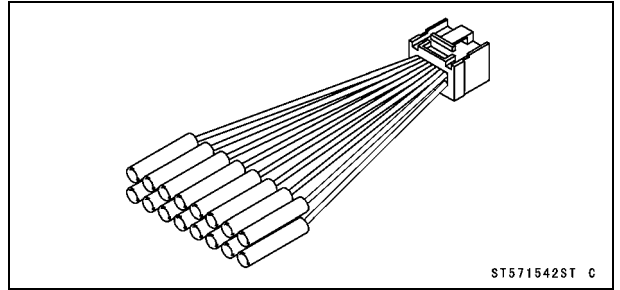

**Peak Voltage Adapter:  
57001-1415**

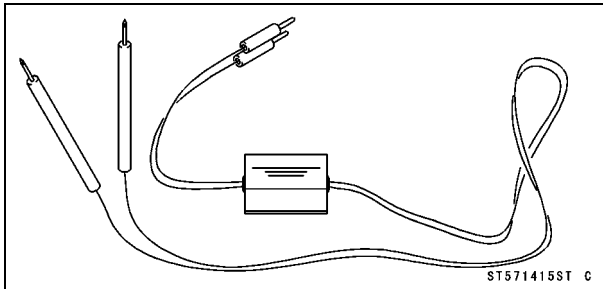

**Key Registration Unit:  
57001-1582**

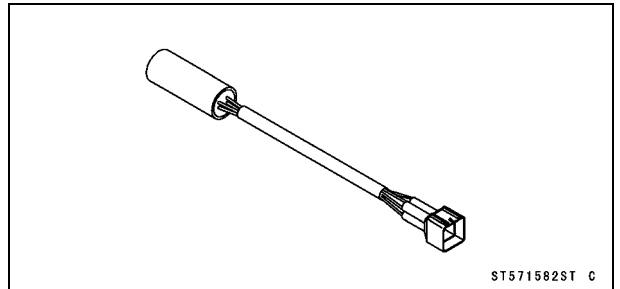

**Lead Wire - Peak Voltage Adapter:  
57001-1449**

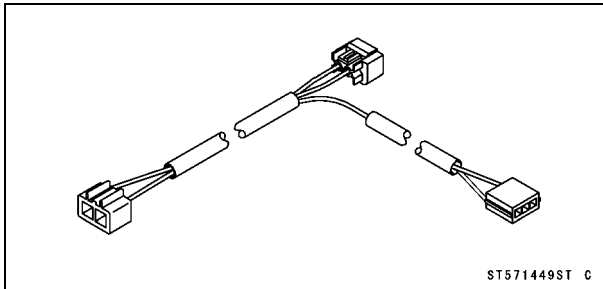

**Flywheel & Pulley Holder:  
57001-1605**

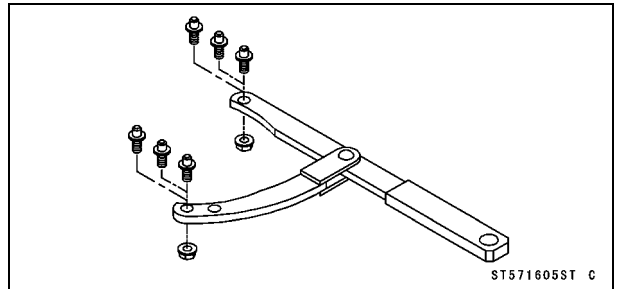

## 16-16 ELECTRICAL SYSTEM

---

### Precautions

---

There are a number of important precautions that are musts when servicing electrical systems. Learn and observe all the rules below.

- Do not reverse the battery lead connections. This will burn out the diodes on the electrical parts.
- Always check battery condition before condemning other parts of an electrical system. A fully charged battery is a must for conducting accurate electrical system tests.
- The electrical parts should never be struck sharply, as with a hammer, or allowed to fall on a hard surface. Such a shock to the parts can damage them.
- To prevent damage to electrical parts, do not disconnect the battery leads or any other electrical connections when the ignition switch is on, or while the engine is running.
- Because of the large amount of current, never keep the starter button pushed when the starter motor will not turn over, or the current may burn out the starter motor windings.
- Do not use a meter illumination bulb rated for other than voltage or wattage specified in the wiring diagram, as the meter or gauge panel could be warped by excessive heat radiated from the bulb.
- Take care not to short the leads that are directly connected to the battery positive (+) terminal to the chassis ground.
- Troubles may involve one or in some cases all items. Never replace a defective part without determining what CAUSED the failure. If the failure was caused by some other item or items, they must be repaired or replaced, or the new replacement will soon fail again.
- Make sure all connectors in the circuit are clean and tight, and examine wires for signs of burning, fraying, etc. Poor wires and bad connections will affect electrical system operation.
- Measure coil and winding resistance when the part is cold (at room temperature).
- Color Codes:

BK: Black	LG: Light Green
BL: Blue	O: Orange
BR: Brown	P: Pink
CH: Chocolate	PU: Purple
DG: Dark Green	R: Red
G: Green	W: White
GY: Gray	Y: Yellow
LB: Light Blue	

**Precautions**

○Electrical Connectors  
Female Connectors [A]

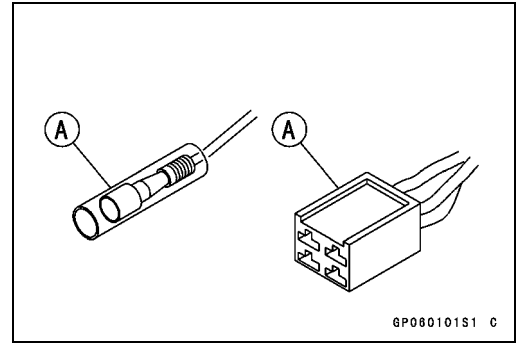

Male Connectors [B]

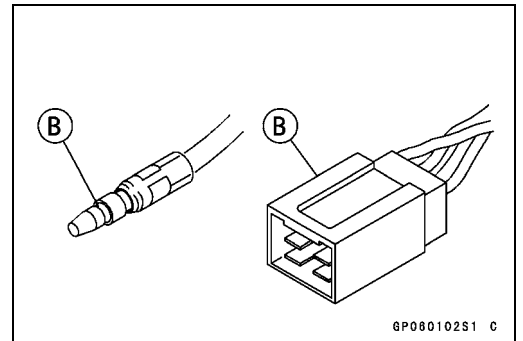

# 16-18 ELECTRICAL SYSTEM

## Electrical Wiring

### Wiring Inspection

- Visually inspect the wiring for signs of burning, fraying, etc.
- ★ If any wiring is poor, replace the damaged wiring.
- Pull each connector [A] apart and inspect it for corrosion, dirt, and damage.
- ★ If the connector is corroded or dirty, clean it carefully. If it is damaged, replace it.
- Check the wiring for continuity.
- Use the wiring diagram to find the ends of the lead which is suspected of being a problem.
- Connect the hand tester between the ends of the leads.

#### Special Tool - Hand Tester: 57001-1394

- Set the tester to the  $\times 1 \Omega$  range, and read the tester.
- ★ If the tester does not read  $0 \Omega$ , the lead is defective. Replace the lead or the wiring harness [B] [C] [D] [E] if necessary.

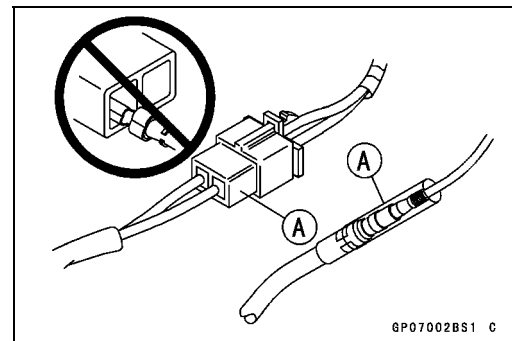
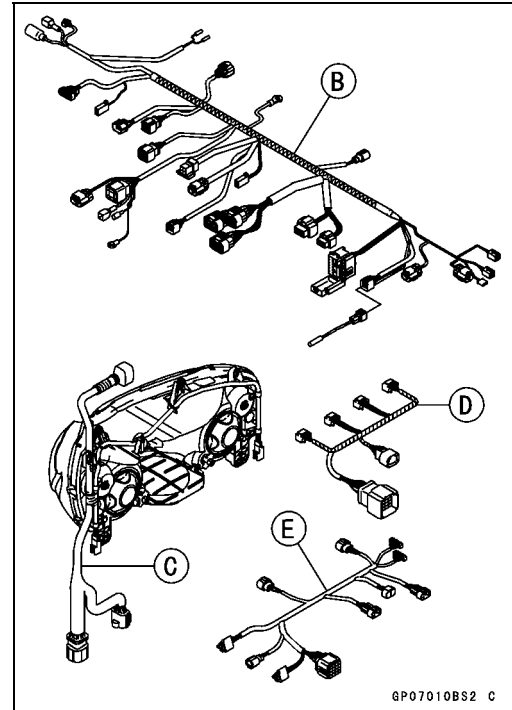

## Battery

### Battery Removal

- Remove the seats (see Frame chapter).
- Remove:
  - Bolts [A]



- Slide the caps [A].
- Disconnect the negative (-) cable [B] and then positive (+) cable [C].

### CAUTION

**Be sure to disconnect the negative (-) cable first.**

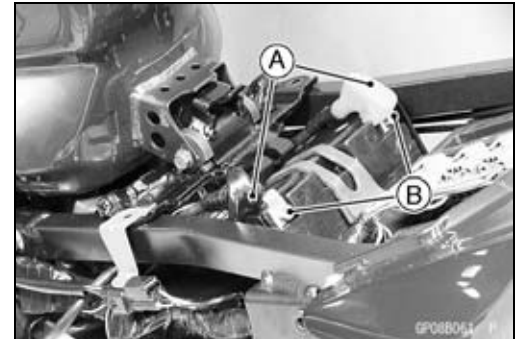

- Lift rear part the fuel tank [A] with tank bracket little.
- Disconnect the band [B].
- Remove the battery [C].



### Battery Installation

- Visually inspect the surface of the battery container.
- ★ If any signs of cracking or electrolyte leakage from the sides of the battery.
- Face the (+) terminal upward.
- Lift the rear part of the fuel tank little and put the battery into the battery case.
- Install the band [A].
- Connect the positive cable [B] (red cap) to the (+) terminal first, and then the negative cable [C] to the (-) terminal.
- Apply a light coat of grease on the terminals to prevent corrosion.
- Cover the terminals with the caps [D].
- Install the bracket bolt with the fuel pump bracket [E] as shown.

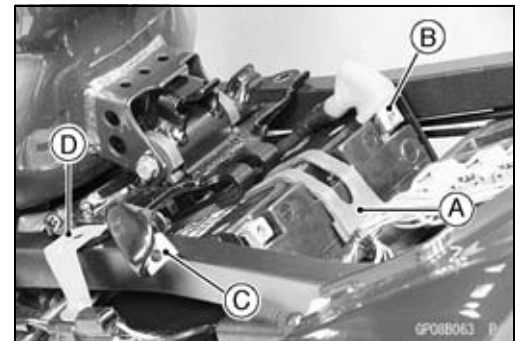

### CAUTION

**If each battery cable is not correctly disconnected or connected, sparks can arise at electrical connections, causing damage to electrical and DFI parts.**

# 16-20 ELECTRICAL SYSTEM

## Battery

### Battery Activation

#### Electrolyte Filling

- Make sure that the model name [A] of the electrolyte container matches the model name [B] of the battery. These names must be the same.

**Battery Model Name for ZX1000-C1: YT12B-BS**

#### CAUTION

Be sure to use the electrolyte container with the same model name as the battery since the electrolyte volume and specific gravity vary with the battery type. This is to prevent overfilling of the electrolyte, shorting the battery life, and deterioration of the battery performance.

#### CAUTION

Do not remove the aluminum sealing sheet [A] from the filler ports [B] until just prior to use. Be sure to use the dedicated electrolyte container for correct electrolyte volume.

- Place the battery on a level surface.
- Check to see that the sealing sheet has no peeling, tears, or holes in it.
- Remove the sealing sheet.

#### NOTE

○The battery is vacuum sealed. If the sealing sheet has leaked air into the battery, it may require a longer initial charge.

- Remove the electrolyte container from the vinyl bag.
- Detach the strip of caps [A] from the container and set aside, these will be used later to seal the battery.

#### NOTE

○Do not pierce or otherwise open the sealed cells [B] of the electrolyte container. Do not attempt to separate individual cells.

- Place the electrolyte container upside down with the six sealed cells into the filler ports of the battery. Hold the container level, push down to break the seals of all six cells. You will see air bubbles rising into each cell as the ports fill.

#### NOTE

○Do not tilt the electrolyte container

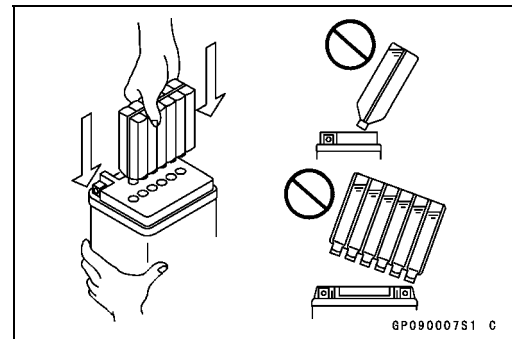
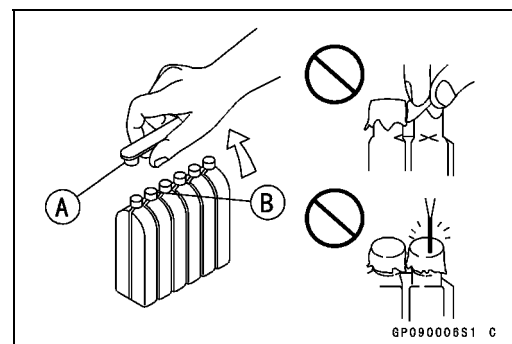
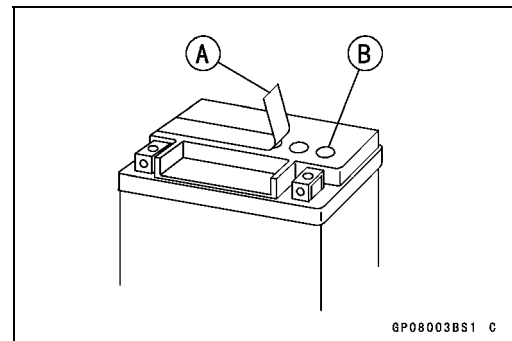
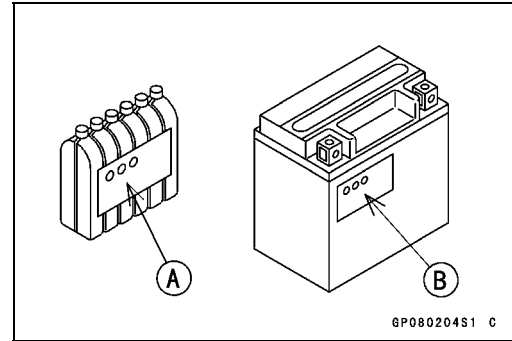

## Battery

- Check the electrolyte flow.
- ★ If no air bubbles [A] are coming up from the filler ports, or if the container cells have not emptied completely, tap the container [B] a few times.
- Keep the container in place for **20** minutes or more. Don't remove the container from the battery until it's empty, the battery requires all the electrolyte from the container for proper operation.

### CAUTION

**Removal of the container before it is completely empty can shorten the service life of the battery. Do not remove the electrolyte container until it is completely empty and 20 minutes have elapsed.**

- Gently remove the container from the battery.
- Let the battery sit for **60** minutes prior to charging to allow the electrolyte to permeate into the plates for optimum performance.

### NOTE

○ *Charging the battery immediately after filling can shorten service life. Let the battery sit for at least 60 minutes after filling.*

### Initial Charge

- Place the strip [A] of caps loosely over the filler ports.
- Newly activated sealed batteries require an initial charge.

**Standard Charge: 1.2 A × 5 ~ 10 hours**

- ★ If using a recommended battery charger, follow the charger's instructions for newly activated sealed battery.

**Kawasaki-recommended chargers:**

**Optimate III**

**Yuasa 1.5 Amp Automatic Charger**

**Battery Mate 150-9**

- ★ If the above chargers are not available, use equivalent one.

### NOTE

○ *Charging rates will vary depending on how long the battery has been stored, temperature, and the type of charger used. Let battery sit 30 minutes after initial charge, then check voltage using a voltmeter. If it is not at least 12.6 volts, repeat charging cycle.*

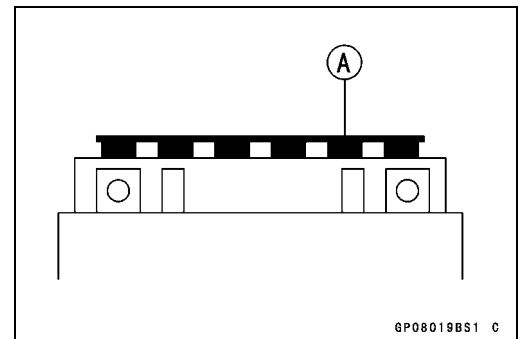
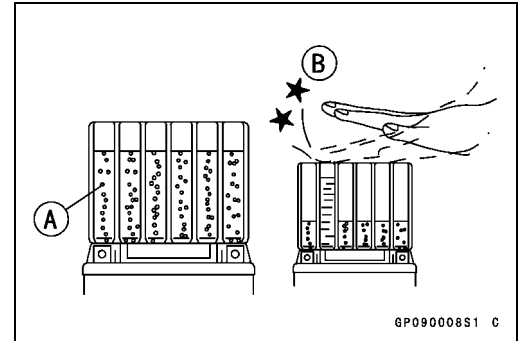

## 16-22 ELECTRICAL SYSTEM

### Battery

- After charging is completed, press down firmly with both hands to seat the strip of caps [A] into the battery (don't pound or hammer). When properly installed, the strip of the caps will be level with the top of the battery.

#### CAUTION

Once the strip of the caps [A] is installed onto the battery, never remove the caps, nor add water or electrolyte to the battery.

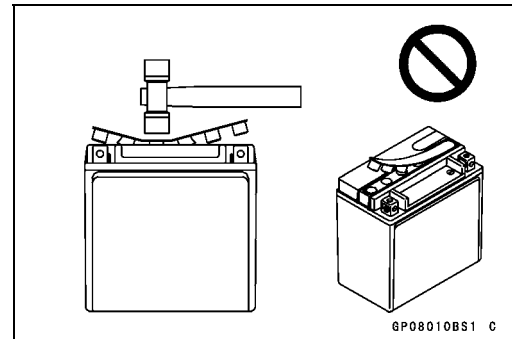
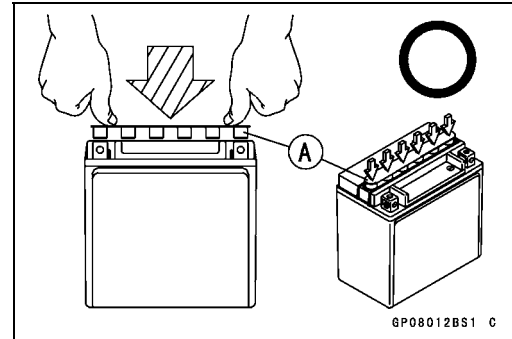

#### NOTE

- To ensure maximum battery life and customer satisfaction, it is recommended the battery be load tested at three times its amp-hour rating for 15 seconds. Re-check voltage and if less than 12.8 volts repeat the charging cycle and load test. If still below 12.8 volts the battery is defective.

#### Precautions

- 1) No need of topping-up

No topping-up is necessary in this battery until it ends its life under normal use. Forcibly prying off the seal cap to add water is very dangerous. Never do that.

- 2) Refreshing charge

If an engine will not start, a horn sounds weak, or lamps are dim, it indicates the battery has been discharged. Give refresh charge for 5 to 10 hours with charge current shown in the specification (see this chapter).

When a fast charge is inevitably required, do it following precisely the maximum charge current and time conditions indicated on the battery.

#### CAUTION

**This battery is designed to sustain no unusual deterioration if refresh-charged according to the method specified above. However, the battery's performance may be reduced noticeably if charged under conditions other than given above. Never remove the seal cap during refresh charge.**

**If by chance an excessive amount of gas is generated due to overcharging, the relief valve releases the gas to keep the battery normal.**

- 3) When you do not use the motorcycle for months:

Give a refresh charge before you store the motorcycle and store it with the negative cable removed. Give a refresh charge **once a month** during storage.

- 4) Battery life:

If the battery will not start the engine even after several refresh charges, the battery has exceeded its useful life. Replace it (Provided, however, the vehicle's starting system has no problem).



## Battery

### ⚠ WARNING

Keep the battery away from sparks and open flames during charging, since the battery gives off an explosive gas mixture of hydrogen and oxygen. When using a battery charger, connect the battery to the charger before turning on the charger.

This procedure prevents sparks at the battery terminals which could ignite any battery gases.

No fire should be drawn near the battery, or no terminals should have the tightening loosened.

The electrolyte contains sulfuric acid. Be careful not to have it touch your skin or eyes. If touched, wash it off with liberal amount of water. Get medical attention if severe.

### Interchange

A sealed battery can fully display its performance only when combined with a proper vehicle electric system. Therefore, replace a sealed battery only on a motorcycle which was originally equipped with a sealed battery.

Be careful, if a sealed battery is installed on a motorcycle which had an ordinary battery as original equipment, the sealed battery's life will be shortened.

### Charging Condition Inspection

○ Battery charging condition can be checked by measuring battery terminal voltage with a digital voltmeter [A].

- Remove:
  - Seats (see Frame chapter)
  - Battery Cable Caps (see this chapter)
- Disconnect the battery terminals.

### CAUTION

Be sure to disconnect the negative (–) cable first.

- Measure the battery terminal voltage.

### NOTE

○ Measure with a digital voltmeter which can be read one decimal place voltage.

- ★ If the reading is 12.8 V or more, no refresh charge is required, however, if the read is below the specified, refresh charge is required.

### Battery Terminal Voltage

Standard: 12.8 V or more

Terminal Voltage (V) [A]

Battery Charge Rate (%) [B]

Good [C]

Refresh charge is required [D]

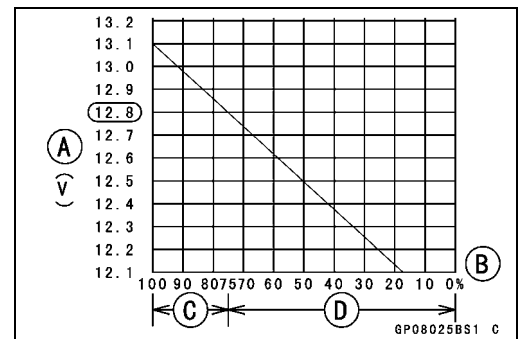
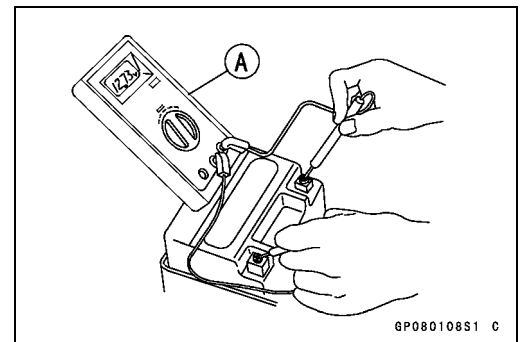

### Refreshing Charge

- Remove the battery [A] (see Battery Removal).
- Do refresh charge by following method according to the battery terminal voltage.

### ⚠ WARNING

This battery is sealed type. Never remove sealing cap [B] even at charging. Never add water. Charge with current and time as stated below.

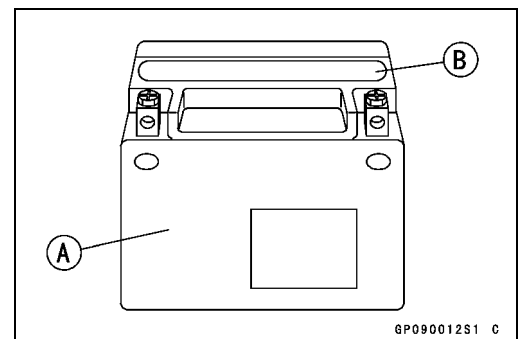

# 16-24 ELECTRICAL SYSTEM

## Battery

Terminal Voltage: 11.5 ~ less than 12.8 V  
 Standard Charge 1.2 A × 5 ~ 10 h (see following chart)  
 Quick Charge 5 A × 1 h

### CAUTION

If possible, do not quick charge. If quick charge is done unavoidably, do standard charge later on.

Terminal Voltage: less than 11.5 V  
 Charging Method: 1.2 A × 20 h

### NOTE

○ Increase the charging voltage to a maximum voltage of 25 V if the battery will not accept current initially. Charge for no more than 5 minutes at the increased voltage then check if the battery is drawing current. If the battery will accept current decrease the voltage and charge by the standard charging method described on the battery case. If the battery will not accept current after 5 minutes, replace the battery.

Battery [A]  
 Battery Charger [B]  
 Standard Value [C]  
 Current starts to flow [D]

- Determine the battery condition after refresh charge.
- Determine the condition of the battery left for 30 minutes after completion of the charge by measuring the terminal voltage according to the table below.

Criteria	Judgement
12.8 V or higher	Good
12.0 ~ lower than 12.8 V	Charge insufficient → Recharge
lower than 12.0 V	Unserviceable → Replace

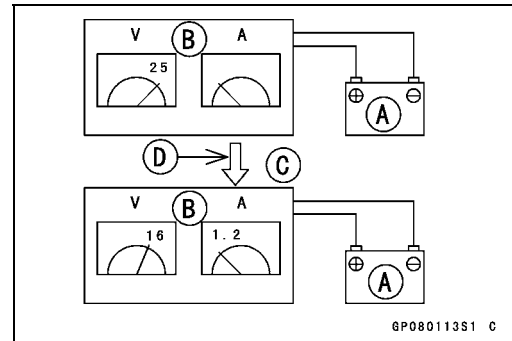
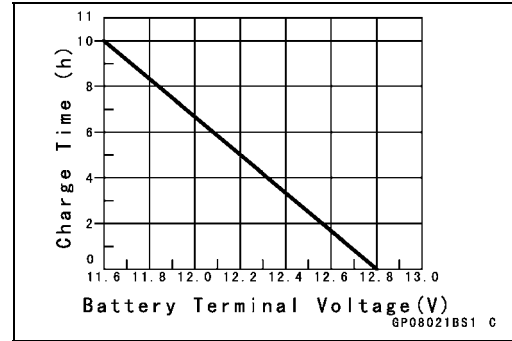

## Charging System

### Alternator Cover Removal

- Remove:
  - Seats (see Frame chapter)
  - Fuel Tank (see Fuel System (DFI) chapter)
  - Throttle Body Assy (see Fuel System (DFI) chapter)
  - Bolts [A]
  - Thermostat Housing [B]

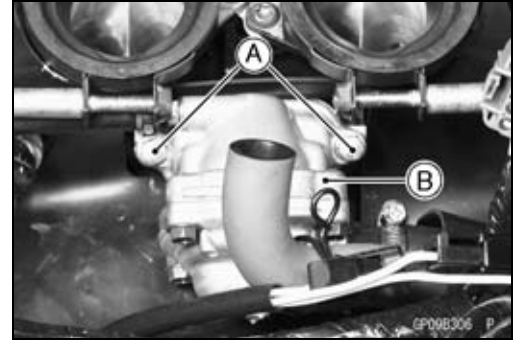

- Remove:
  - Bolts [A]
  - Water Hose Fitting [B]

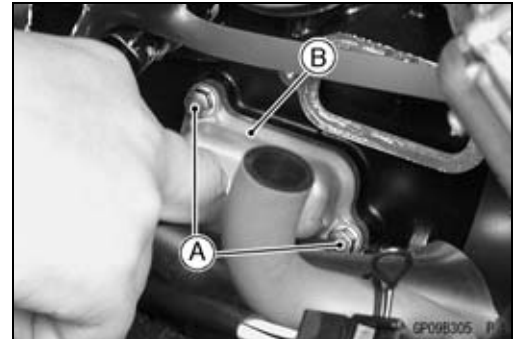

- Remove the clamp.
- Disconnect the alternator lead connectors [A].

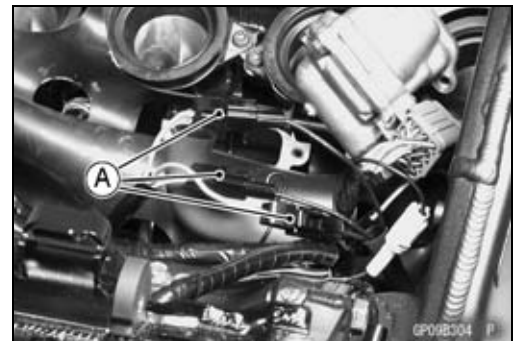

- Remove:
  - Left Lower Fairing (see Frame chapter)
  - Left Middle Fairing (see Frame chapter)
  - Starter Clutch Cover (see this chapter)
  - Water Hoses (see Cooling System chapter)
  - Starter Motor (see this chapter)
  - Bolts [A]
- Pull out the alternator cover [B] with stator coil.

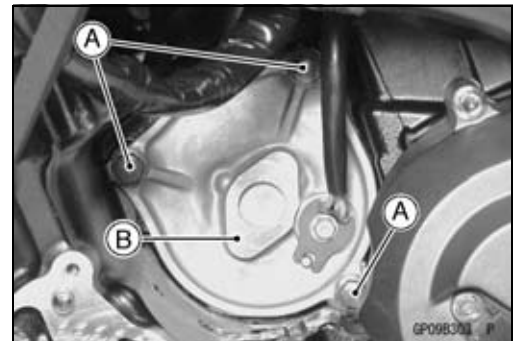

### Alternator Cover Installation

- Replace and apply grease to the O-ring.
- Tighten:
  - Torque - Alternator Cover Bolts: 25 N·m (2.5 kgf·m, 18 ft·lb)**
- Install other removed parts.

# 16-26 ELECTRICAL SYSTEM

## Charging System

### Stator Coil Removal

- Remove:
  - Alternator Cover (see Alternator Cover Removal)
  - Holding Plate Bolts [A] and Plate [B]



- Stator Coil Bolts [A]
- Remove the stator coil [B] from the alternator cover.

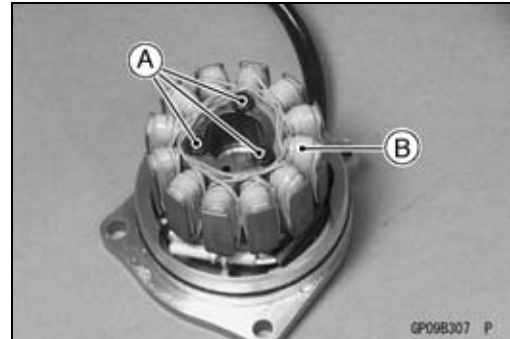

### Stator Coil Installation

- Apply a heavy duty non-permanent locking agent.
    - Specific Locking Agent -**  
**Three Bond 1360N**
  - Tighten:
    - Torque - Stator Coil Bolts: 8.0 N·m (0.80 kgf·m, 71 in·lb)**
  - Fit the grommet into the hole of the cover securely.
  - Secure the alternator lead [A] with a holding plate [B] as shown.
- Torque - Alternator Lead Holding Plate Bolts: 6.0 N·m (0.61 kgf·m, 53 in·lb)**
- Install the alternator cover (see Alternator Cover Installation).

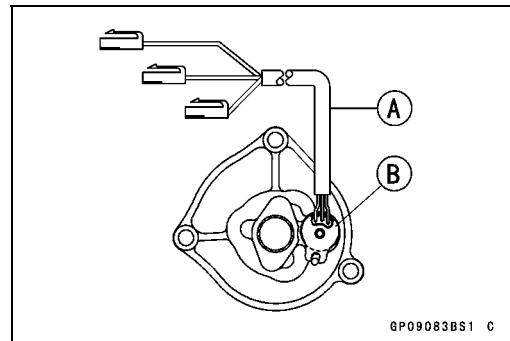

### Alternator Rotor Removal

- Remove:
  - Alternator Cover Bolts (see Alternator Cover Removal)
  - Clutch Cover Bolts [A]
  - Clutch Cable [B]
  - Clutch Cable Holder [C]

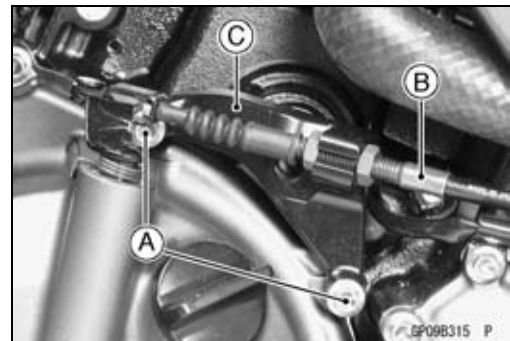

## Charging System

- Loosen:  
Alternator Shaft Clamp Bolt [A]  
Alternator Shaft Spring Bolt [B]

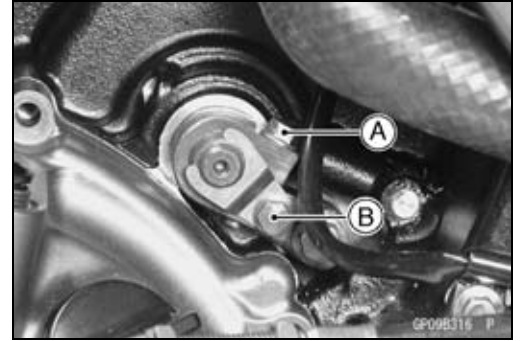

- Push the shaft end [A] by a suitable stick [B].
- Remove the alternator assembly from right side of the engine.

### CAUTION

**Do not tap the shaft end while removing the alternator.**



- Pull out the alternator cover [A] with the stator.

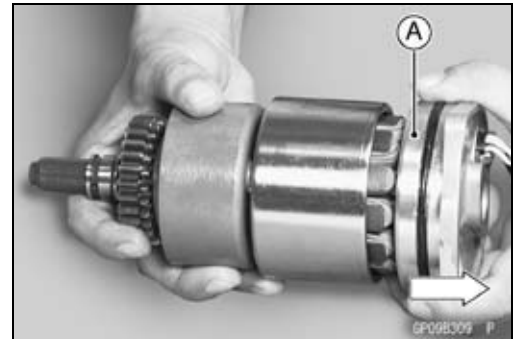

- Remove:  
Circlip [A]  
Toothed Washer [B]  
Spacer

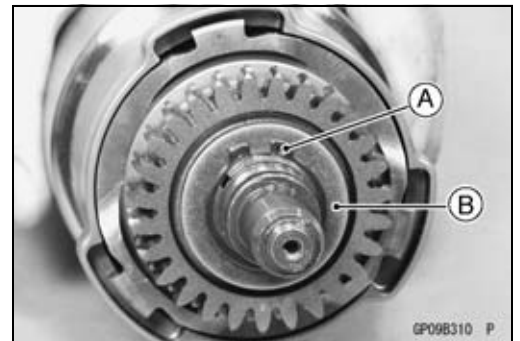

- Remove the shaft [A] from the coupling assembly [B].

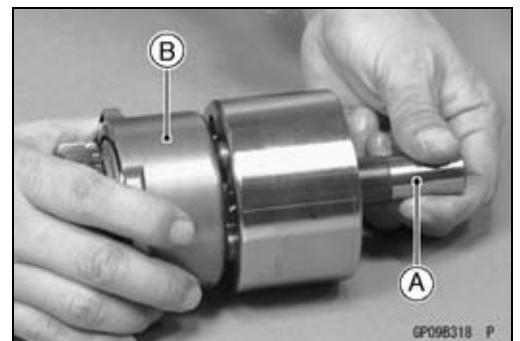

# 16-28 ELECTRICAL SYSTEM

## Charging System

- Separate the coupling [A] and gear [B].

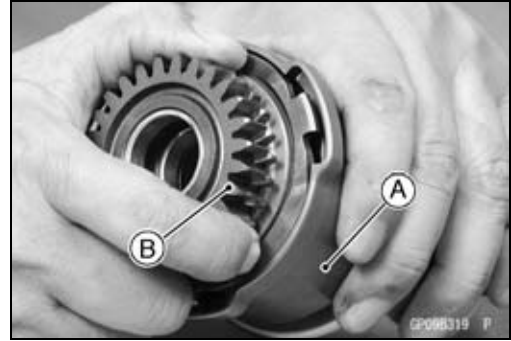

- Remove the rubber dampers [A].



### Alternator Rotor Installation

- Inspect the rubber dampers [A].

#### NOTE

○ If any dampers show signs of damage or deteriorated, replace the dampers as a set.

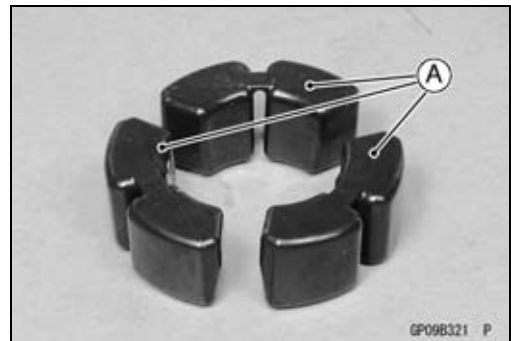

- Install the rubber dampers [A] as shown.  
Rib [B]

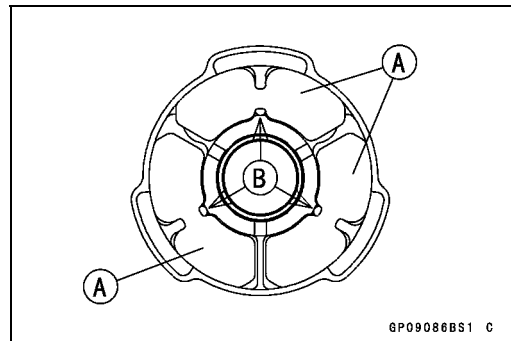

- Apply engine oil to the vanes [A] of the gear.
- Install the gear to the coupling.

#### CAUTION

A improper for assembling gear tooth contact could causes gear noise.

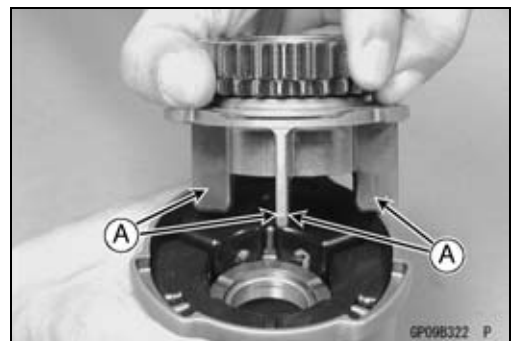

**Charging System**

- If the gear assembly [A] is replaced with new one, select the proper gear assembly in accordance with the combination of the gear assembly and clutch housing gear [B] markings.

Clutch Housing Gear Mark [C]  
 Gear Assembly Mark [D]

**Gear Assembly Selection when Replacing Gear Assembly**

Clutch Housing Gear Making	Gear Assembly (Alternator)	
	Marking	Part Number
A	A	16085-0041
B	B	16085-0042
C	C	16085-0044
D	D	16085-0045
None	None	16085-0043

**NOTE**

- If the selection mark is missing or not selection, refer to the selection section in the specifications of the crankshaft/Transmission chapter.
- Be sure to confirm the marking on the gear assembly.

- Apply molybdenum disulfide oil solution [A] to the alternator shaft [B].
- Install:
  - Spacer [C]
  - Toothed Washer [D]
  - New Circlip [E]
  - Alternator Rotor Assembly [F]
  - Spacer
  - Toothed Washer
  - New Circlip

- Install the toothed washers as shown.
  - Groove [A]
  - Tooth [B]

- Using a thickness gauge [A], measure the clearance between the spacer [B] and toothed washer [C].

**Alternator Assembly Play**

Standard: 0.6 ~ 0.9 mm (0.024 ~ 0.035 in.)

- ★ If the clearance is not within the specified range, adjust it.

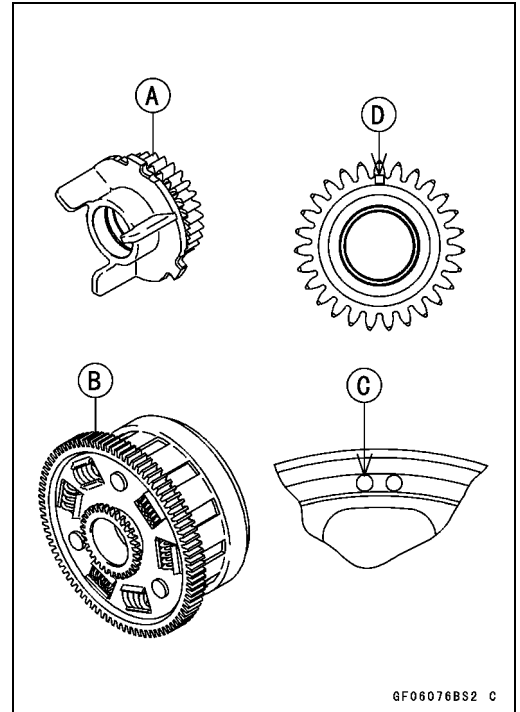

GF06076BS2 C

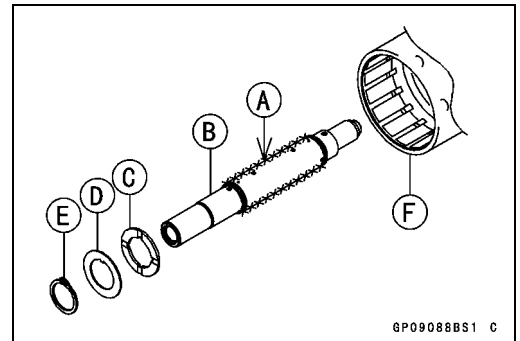

GP09088BS1 C

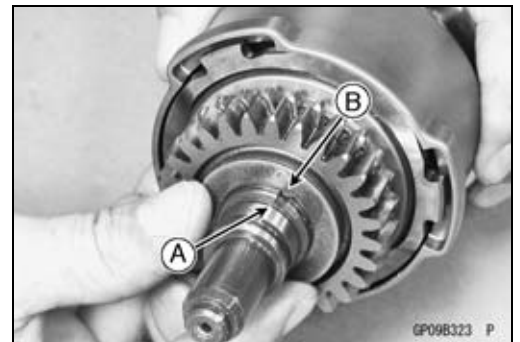

GP09B323 P

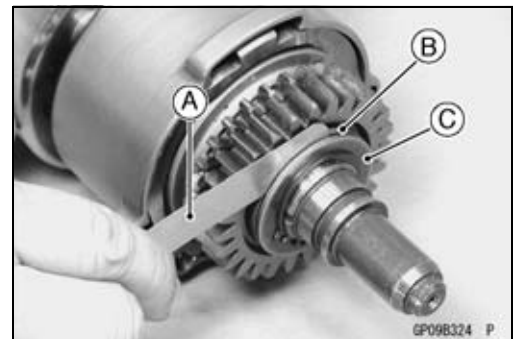

GP09B324 P

# 16-30 ELECTRICAL SYSTEM

## Charging System

- Replace the toothed washer which brings the clearance within the specified range.
- Remove:
  - Circlip
  - Toothed Washer
- Replace the following toothed washer(s).

Part Number	Thickness
92200-0123	1.0 mm (0.039 in.)
92200-0124	1.2 mm (0.047 in.)
92200-0125	1.4 mm (0.055 in.)
92200-0126	1.6 mm (0.063 in.) (standard)
92200-0127	1.8 mm (0.071 in.)
92200-0128	2.0 mm (0.008 in.)
92200-0129	2.3 mm (0.090 in.)

### NOTE

○ Do not use two or more toothed washer at same time.

- Remove:
  - Right Lower Fairing (see Frame chapter)
  - Clutch (see Clutch chapter)
- Install:
  - Alternator Rotor Assembly
  - Alternator Cover with Stator (see this chapter)
- Tighten:
  - Torque - Alternator Cover Bolts: 25 N·m (2.5 kgf·m, 18 ft·lb)**
- Tighten the spring bolt [A] first, then tighten the clamp bolt [B].
  - Torque - Alternator Shaft Spring Bolt: 9.8 N·m (1.0 kgf·m, 87 in·lb)**
  - Alternator Shaft Clamp Bolt: 12 N·m (1.2 kgf·m, 104 in·lb)**
- Install the clutch housing [C] (see Clutch chapter).

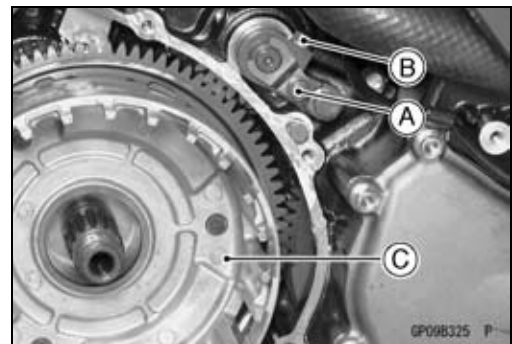

### Alternator Lever Removal

- Remove:
  - Alternator Shaft Spring [A]
  - Alternator Shaft Lever [B]
- Unscrew the spring bolt [C] first, next the clamp bolt [D], last the lever bolt [E].

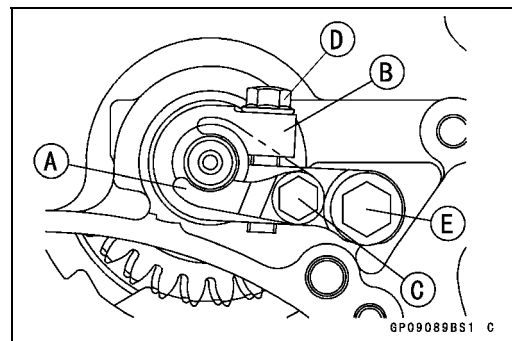



## Charging System

### Alternator Lever Installation

- Apply grease to the oil seal lip.
- Install the alternator shaft lever until its surface is in contact with the crankcase.
- Apply a non-permanent locking agent to the lever bolt.
- Tighten:

**Torque - Alternator Shaft Lever Bolt: 25 N·m (2.5 kgf·m, 18 ft·lb)**

**Alternator Shaft Spring Bolt: 9.8 N·m (1.0 kgf·m, 87 in·lb)**

**Alternator Shaft Clamp Bolt: 12 N·m (1.2 kgf·m, 104 in·lb)**

### Alternator Inspection

There are three types of alternator failures: short, open (wire burned out), or loss in rotor magnetism. A short or open in one of the coil wires will result in either a low output, or no output at all. A loss in rotor magnetism, which may be caused by dropping or hitting the alternator, by leaving it near an electromagnetic field, or just by aging, will result in low output.

- To check the alternator output voltage, do the following procedures.
  - Turn off the ignition switch.
  - Remove:
    - Fuel Tank (see Fuel System (DFI) chapter)
    - Air Cleaner Housing (see Fuel System (DFI) chapter)
    - Band [A]
  - Disconnect the alternator lead connectors [B].

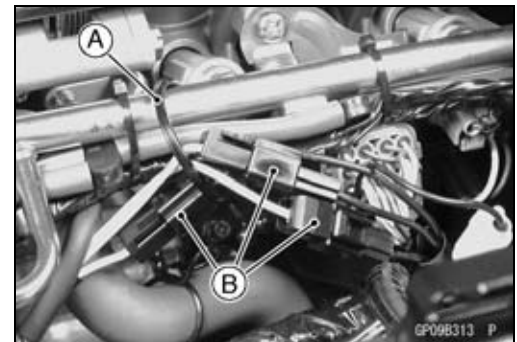

- Using the auxiliary leads [A] connect the alternator lead connector to the tester lead.
- Reinstall:
  - Fuel Tank (see Fuel System (DFI) chapter)
  - Air Cleaner Housing (see Fuel System (DFI) chapter)
- Connect the hand tester [B] as shown in the table 1.
- Start the engine, and run it 6 000 rpm 5 minutes.
- Run it at the rpm given in the table 1.
- Note the voltage readings (total 3 measurements).

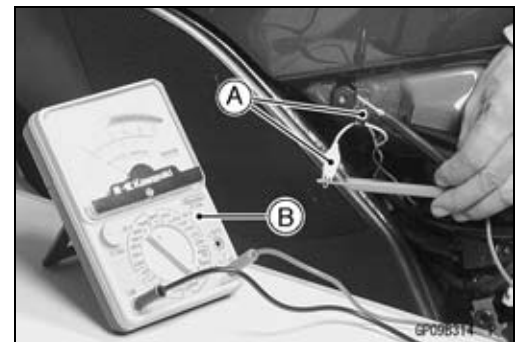

**Table 1: Alternator Output Voltage**

Tester Range	Connections		Reading @ 4 000 rpm
	Tester (+) to	Tester (-) to	
250 V AC	One Black Lead	Another Black Lead	42 V or more

- ★ If the output voltage shows the value in the table, the alternator operates properly.
- ★ If the output voltage shows a much higher than the value in the table, the regulator/rectifier is damaged. A much lower reading than that given in the table indicates that the alternator is defective.

# 16-32 ELECTRICAL SYSTEM

## Charging System

- Check the stator coil resistance as follows.
- Stop the engine.
- Connect the commercially available tester as shown in the table 2.
- Note the readings (total 3 measurement).

**Table 2: Stator Coil Resistance**

Tester Range	Connections		Reading
	Tester (+) to	Tester (-) to	
$\times 1 \Omega$	One Black Lead	Another Black Lead	0.05 ~ 0.5 $\Omega$

- ★ If there is more resistance than shown in the table, or no tester reading (infinity) for any two leads, the stator has an open lead and must be replaced. Much less than this resistance means the stator is shorted, and must be replaced.
- Using the highest resistance range of the hand tester, measure the resistance between each of the black leads and chassis ground.
- ★ Any hand tester reading less than infinity ( $\infty$ ) indicates a short, necessitating stator replacement.
- ★ If the stator coils have normal resistance, but the voltage check showed the alternator to be defective; then the rotor magnets have probably weakened, and the rotor must be replaced.

### Regulator/rectifier Inspection

- Remove:
  - Bolts [A]
  - Regulator/rectifier [B]

Connectors [A]

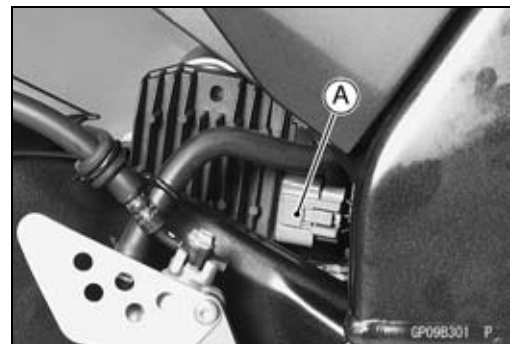
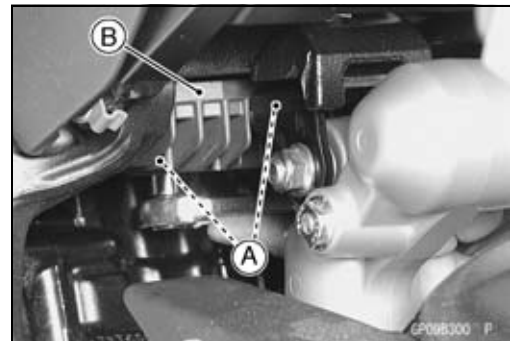

## Charging System

### Regulator/rectifier Inspection

- Set the hand tester to the  $\times 1$  k $\Omega$  range and make the measurements shown in the table.

**Special Tool - Hand Tester: 57001-1394**

- Connect the hand tester to the regulator rectifier.
- ★ If the tester readings are not as specified, replace the regulator/rectifier.

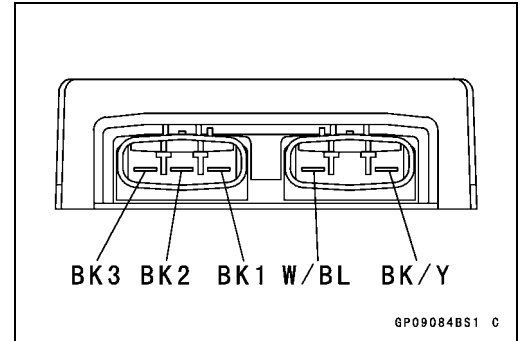

### CAUTION

**Use only Kawasaki Hand Tester 57001-1394 for this test. A tester other than the Kawasaki Hand Tester may show different readings.**  
**If a megger or a meter with a large capacity battery is used, the regulator/rectifier will be damaged.**

### Regulator/rectifier Resistance (Unit: k $\Omega$ )

		Tester (+) Lead Connection				
		Terminal	W/BL	BK1	BK2	BK3
(-)*	W/BL	—	20 ~ 300	20 ~ 300	20 ~ 200	20 ~ 750
	BK1	0 ~ 5	—	20 ~ 300	20 ~ 200	20 ~ 750
	BK2	0 ~ 5	20 ~ 300	—	20 ~ 200	20 ~ 750
	BK3	0 ~ 5	20 ~ 300	20 ~ 300	—	20 ~ 750
	BK/Y	5 ~ 20	5 ~ 20	5 ~ 20	5 ~ 20	—

(-)\*: Tester (-) Lead Connection

### Charging Voltage Inspection

- Check the battery condition (see Battery section).
- Warm up the engine to obtain actual alternator operating conditions.
- Remove:
  - Seats (see Frame chapter)
  - Caps
- Check that the ignition switch is turned off, and connect the hand tester [A] as shown in the table.

**Special Tool - Hand Tester: 57001-1394**

- Start the engine, and note the voltage readings at various engine speeds with the headlight turned on and then turned off. (Disconnect the headlight connector in the upper fairing.) The readings should show nearly battery voltage when the engine speed is low, and, as the engine speed rises, the readings should also rise. But they must be kept under the specified voltage.

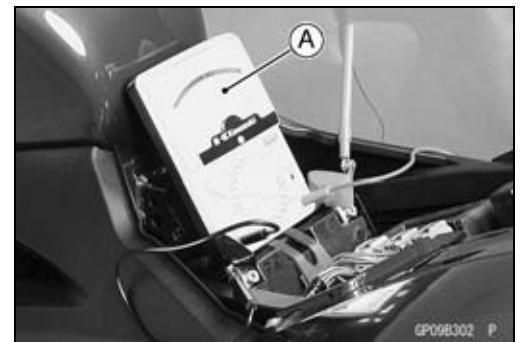

### Charging Voltage

Tester Range	Connections		Reading
	Tester (+) to	Tester (-) to	
25 V DC	Battery (+)	Battery (-)	14.2 ~ 15.2 V

# 16-34 ELECTRICAL SYSTEM

## Charging System

- Turn off the ignition switch to stop the engine, and disconnect the hand tester.
- ★ If the charging voltage is kept between the values given in the table, the charging system is considered to be working normally.
- ★ If the charging voltage is much higher than the values specified in the table, the regulator/rectifier is defective or the regulator/rectifier leads are loose or open.
- ★ If the charging voltage does not rise as the engine speed increases, then the regulator/rectifier is defective or the alternator output is insufficient for the loads. Check the alternator and regulator/rectifier to determine which part is defective.

### Charging System Circuit

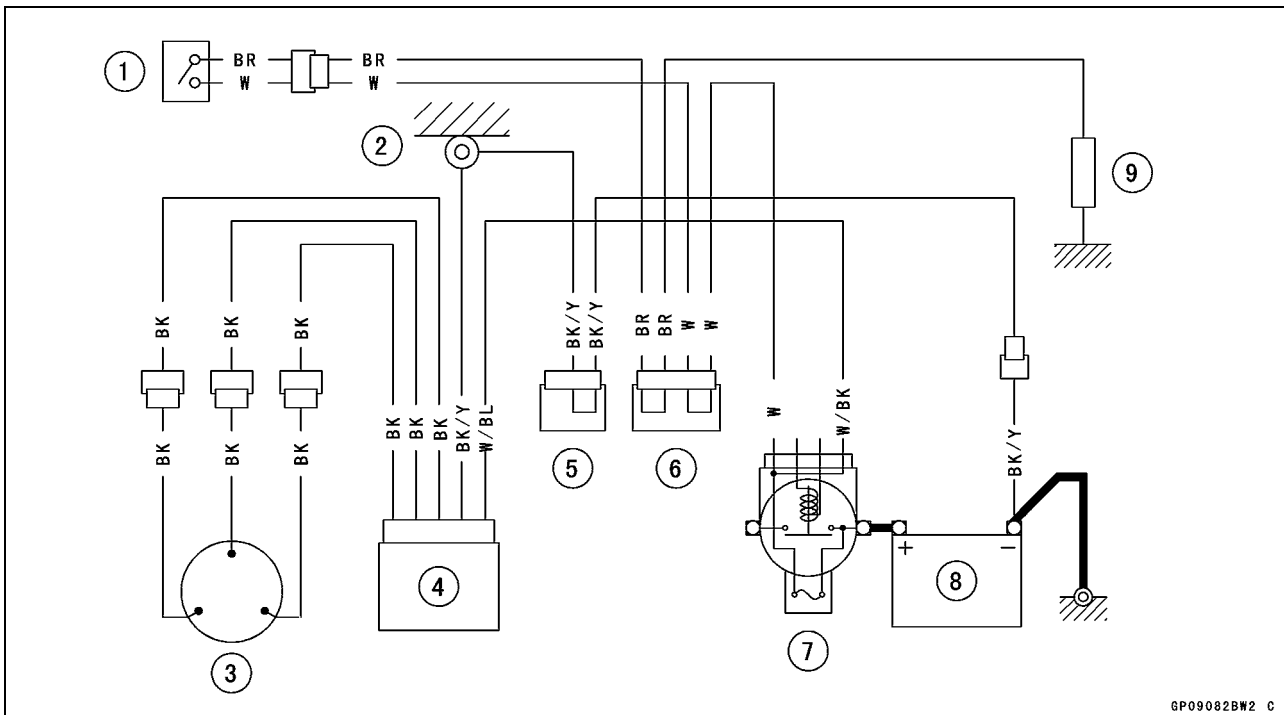

GP09082BW2 C

1. Ignition Switch
2. Frame Ground
3. Alternator
4. Regulator/rectifier
5. Joint Connector 2
6. Joint Connector 4
7. Main Fuse 30 A
8. Battery 12 V 10 Ah
9. Load

Ignition System

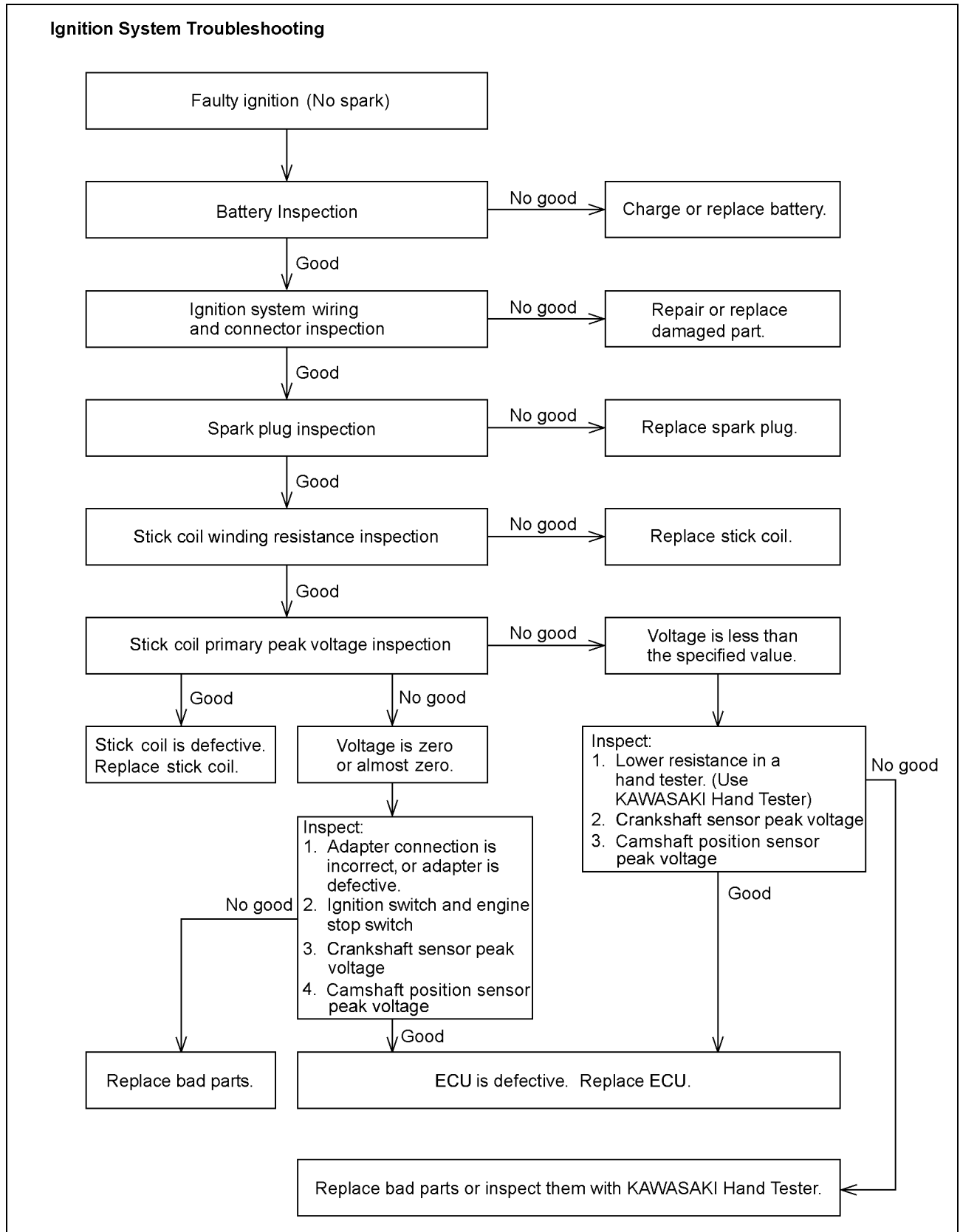

## 16-36 ELECTRICAL SYSTEM

### Ignition System

#### **⚠ WARNING**

The ignition system produces extremely high voltage. Do not touch the spark plugs or stick coils while the engine is running, or you could receive a severe electrical shock.

#### **CAUTION**

Do not disconnect the battery leads or any other electrical connections when the ignition switch is on, or while the engine is running. This is to prevent IC igniter damage.

Do not install the battery backwards. The negative side is grounded. This is to prevent damage to the diodes and IC igniter.

#### *Crankshaft Sensor Removal*

- Remove:
  - Fuel Tank (see Fuel System (DFI) chapter)
  - Air Cleaner Housing (see Fuel System (DFI) chapter)
  - Lower Fairing (see Frame chapter)
  - Screw [A]
  - Crankshaft Sensor Lead Connector [B]
  
- Remove:
  - Bolts [A]
  - Crankshaft Sensor Cover [B]
  
- Remove the crankshaft sensor [A] by taking off the crankshaft sensor bolts [B].
- Pull out the grommet [C].

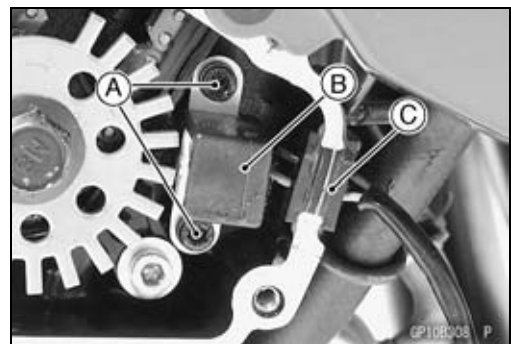
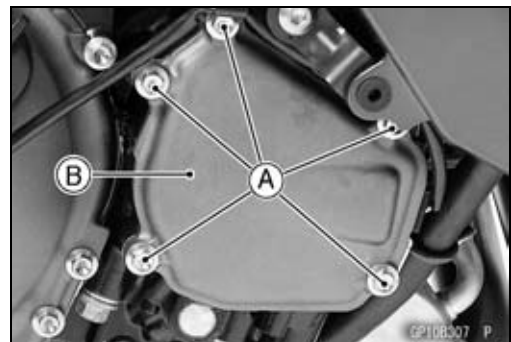

## Ignition System

### Crankshaft Sensor Installation

- Route the crankshaft sensor lead correctly (see Appendix chapter).
- Tighten:
  - Torque - Crankshaft Sensor Bolts: 6.0 N·m (0.61 kgf·m, 53 in·lb)**
- Apply silicone sealant.
  - Crankshaft Sensor Lead Grommet [A] (around)
  - Crankcase Halves Mating Surfaces [B]
- **Sealant - Three Bond (Silicone Sealant): TB1211F**
- Install the gasket [C].
- Apply a non-permanent locking agent.
  - Crankshaft Sensor Cover Bolts
- Install the bolts with clamps [A].
- Tighten:
  - Torque - Crankshaft Sensor Cover Bolts: 9.8 N·m (1.0 kgf·m, 87 in·lb)**
- Connect sensor lead connector.
- Install the other remove parts.

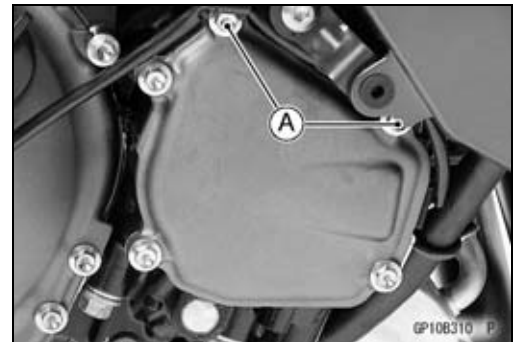
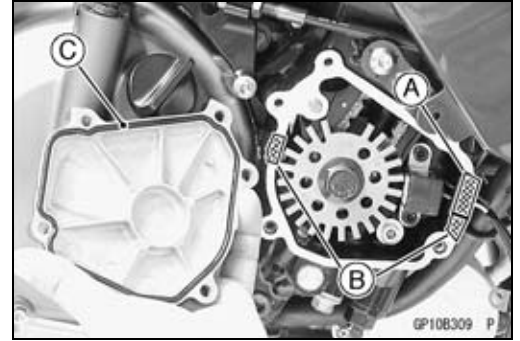

### Crankshaft Sensor Inspection

- Remove:
  - Crankshaft Sensor Lead Connector (see Crankshaft Sensor Removal)
- Set the hand tester [A] to the  $\times 100 \Omega$  range and connect the (+) lead to the black lead and (-) lead to the yellow lead in the connector [B].
- **Special Tool - Hand Tester: 57001-1394**
- ★ If there is more resistance than the specified value, the coil has an open lead and must be replaced. Much less than this resistance means the coil is shorted, and must be replaced.

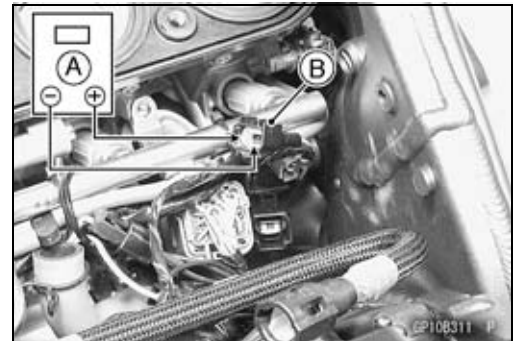

**Crankshaft Sensor Resistance: 380 ~ 570  $\Omega$**

- Using the highest resistance range of the tester, measure the resistance between the crankshaft sensor leads and chassis ground.
- ★ Any tester reading less than infinity ( $\infty$ ) indicates a short, necessitating replacement of the crankshaft sensor assembly.

### Crankshaft Sensor Peak Voltage

#### NOTE

- Be sure the battery is fully charged.
- Using the peak voltage adapter is a more reliable way to determine the condition of the crankshaft sensor than crankshaft sensor internal resistance measurements.
- Remove:
  - Crankshaft Sensor Lead Connector (see Crankshaft Sensor Removal)

## 16-38 ELECTRICAL SYSTEM

### Ignition System

- Set the hand tester [A] to the  $\times 10$  V DC range, and connect it a commercially available peak voltage adapter [B].
- Connect the black lead (-) [D] of the adapter to yellow lead and red lead (+) [C] to black lead in the crankshaft sensor connector [E].
- Turn the ignition switch on and engine stop switch on.

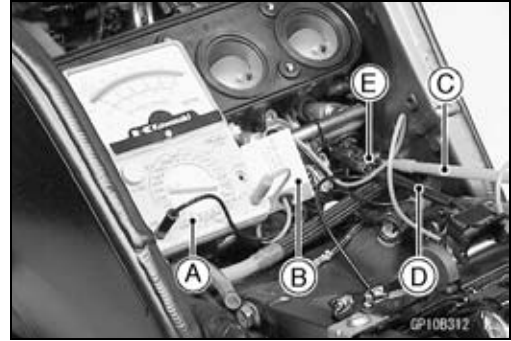

- Pushing the starter button, turn the engine 4 ~ 5 seconds with the transmission gear in neutral to measure the crankshaft sensor peak voltage.
- Repeat the measurement 5 or more times.

**Crankshaft Sensor Peak Voltage**  
**Standard: 3.2 V or more**

**Special Tools - Hand Tester: 57001-1394**  
**Peak Voltage Adapter: 57001-1415**  
**Type: KEK-54-9-B**

- ★ If the tester reading is not specified one, check the crankshaft sensor.

#### *Timing Rotor Removal*

- Remove the crankshaft sensor cover (see Crankshaft Sensor Removal).
- Remove the timing rotor [A].
- Holding the timing rotor with the flywheel and pulley holder [B] and unscrew the bolt [C].

**Special Tool - Flywheel and Pulley Holder: 57001-1605**

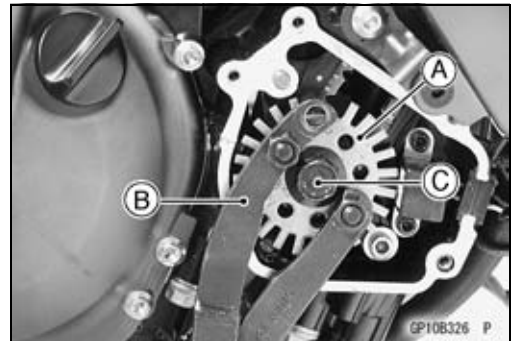

#### *Timing Rotor Installation*

- Fit the rotor to the crankshaft.
- Tighten the rotor bolt.

**Torque - Timing Rotor Bolt: 40 N·m (4.0 kgf·m, 29 ft·lb)**

**Special Tool - Flywheel and Pulley Holder: 57001-1605**

- Install the crankshaft sensor cover (see Crankshaft Sensor Cover Installation).

#### *Stick Coil (Ignition Coil together with Spark Plug Cap) Removal*

- Remove:
  - Air Cleaner Housing (see Fuel System (DFI) chapter)
  - Right and Left Air Ducts [A] (see Fuel System (DFI) chapter)

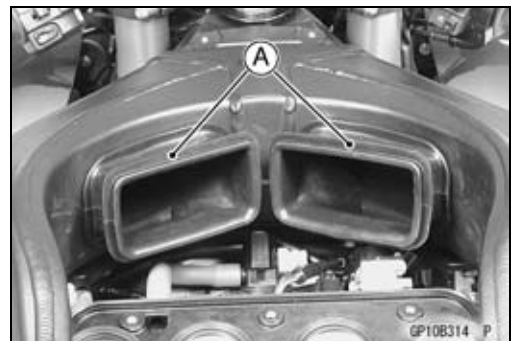



## Ignition System

- Disconnect the stick coil connectors [A].
- Pull the stick coils #2, #3 [B] off the spark plugs.

### CAUTION

**Do not pry the connector part of the coil while removing the coil.**

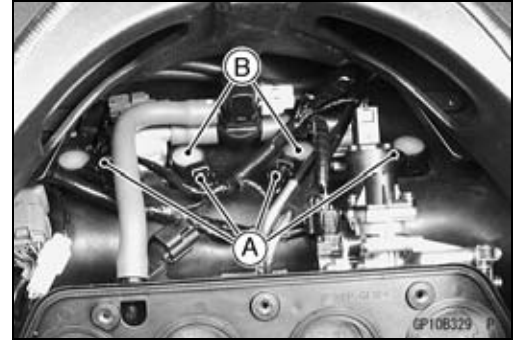

- For remove the stick coil #4 as follows.
  - Remove:
    - Right Lower Fairing (see Frame chapter)
    - Right Middle Fairing (see Frame chapter)
    - Right Lower Engine Bracket Bolts [A]
    - Right Upper Engine Bracket Bolts [B]
  - Pull out the stick coil #4.

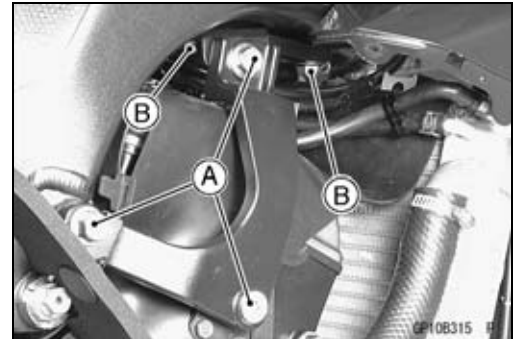

- For remove the stick coil #1 as follows.
  - Remove:
    - Left Lower Fairing (see Frame chapter)
    - Left Middle Fairing (see Frame chapter)
    - Headlight Harness Joint Connector [A]
    - Left Lower Engine Bracket Bolts [B]



- Remove:
  - Left Upper Engine Bracket Bolts [A]
  - Stick Coil Harness Joint Connector Bracket Bolt [B]
- Pull out the stick coil #1.

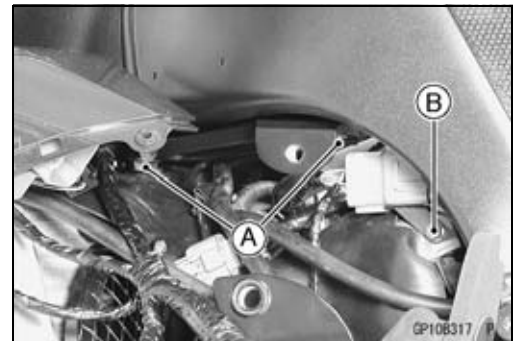

### Stick Coil (Ignition Coil together with Spark Plug Cap) Installation

- Install the coils using the following steps.
  - Insert the coils [A] as shown being careful of the coil installation directions.
  - Connect the connectors.

### CAUTION

**Do not tap the coil head while installing the coil.**

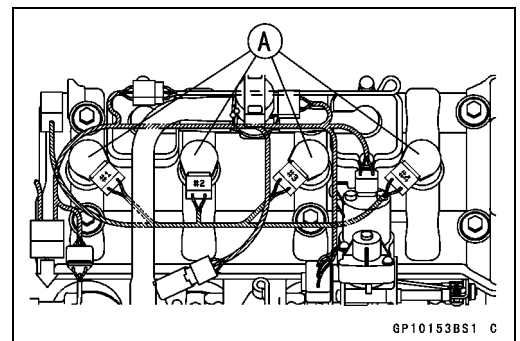

- Run the hoses and harness correctly (see Cable, Wire, and Hose Routing section in Appendix chapter).
- Install other removed parts.

# 16-40 ELECTRICAL SYSTEM

## Ignition System

### Stick Coil (Ignition Coil together with Spark Plug Cap) Inspection

- Remove the stick coils (see this chapter).
- Measure the primary winding resistance [A] as follows.
  - Connect the hand tester between the coil terminals.
  - Set the tester to the  $\times 1 \Omega$  range, and read the tester.
- Measure the secondary winding resistance [B] as follows.
  - Connect the tester between the plug terminal and (-) coil terminal.
  - Set the tester to the  $\times 1 \text{ k}\Omega$  range and read the tester.

#### Ignition Coil Winding Resistance

Primary Windings: 1.2 ~ 1.6  $\Omega$

Secondary Windings: 8.5 ~ 11.5 k $\Omega$

★ If the tester does not read as specified, replace the coil.

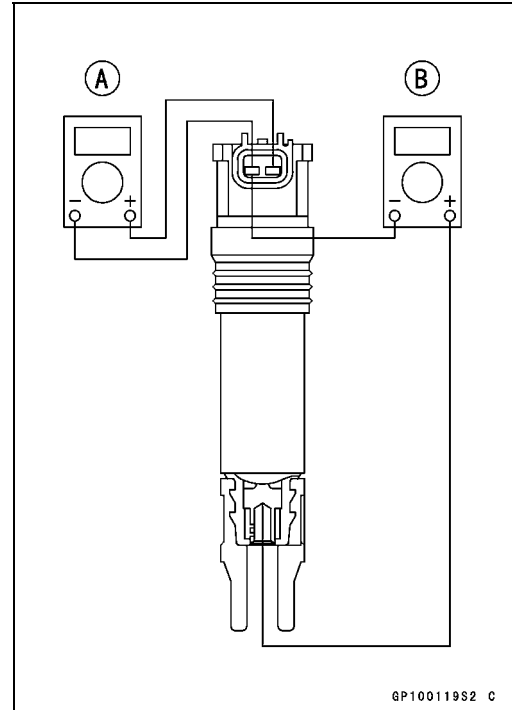

### Stick Coil Primary Peak Voltage

#### NOTE

○ Be sure the battery is fully charged.

- Remove the stick coils (see this chapter), but do not remove the spark plugs.
- Measure the primary peak voltage as follows.
  - Install the new spark plug [A] into each stick coil [B], and ground them onto the engine.
  - Connect a commercially available peak voltage adapter [C] into the hand tester [D] which is set to the  $\times 250 \text{ V DC}$  range.
  - Connect the adapter to the lead wire-peak voltage adapter [E] which is connected between the stick coil connector and stick coil.

[F] ECU

Special Tools - Hand Tester: 57001-1394

Peak Voltage Adapter: 57001-1415

Type: KEK-54-9-B

Lead Wire-Peak Voltage Adapter: 57001-1449

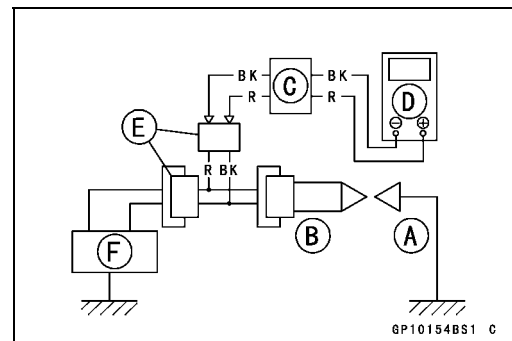
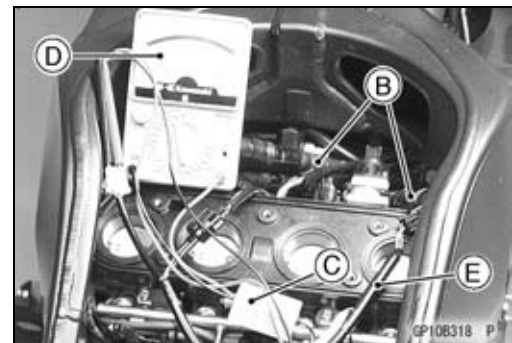

#### Primary Lead Connection

Adapter (R, +) to lead wire-peak voltage adapter:

Stick Coil #1 (BK)

Stick Coil #2 (BK/G)

Stick Coil #3 (BK/W)

Stick Coil #4 (BK/O)

Adapter (BK, -) to lead wire-peak voltage adapter (R)

## Ignition System

### **⚠ WARNING**

**To avoid extremely high voltage shocks, do not touch the spark plugs or tester connections.**

- Turn the ignition switch and the engine stop switch ON.
- Pushing the starter button, turn the engine 4 ~ 5 seconds with the transmission in neutral to measure the primary peak voltage.
- Repeat the measurements 5 times for one stick coil.

#### **Stick Coil Primary Peak Voltage**

**Standard: 72 V or more**

- Repeat the test for the other stick coil.
- ★ If the reading is less than the specified value, check the following.
  - Stick Coils (see Stick Coil Inspection)
  - Crankshaft Sensor (see Crankshaft Sensor Inspection)
  - ECU (see Fuel System (DFI) chapter)

#### **Spark Plug Removal**

- Remove:
  - Air Cleaner Housing (see Fuel System (DFI) chapter)
  - Stick Coils (see Stick Coil Removal)
- Remove the spark plugs using the 16 mm plug wrench [A].

**Owner's Tool - Spark Plug Wrench, 16 mm: 92110-1132**



#### **Spark Plug Installation**

- Insert the spark plug vertically into the plug hole with the plug [A] installed in the plug wrench [B].

**Owner's Tool - Spark Plug Wrench, 16 mm: 92110-1132**

- Tighten:
  - Torque - Spark Plugs: 13 N·m (1.3 kgf·m, 113 in·lb)**
- Fit the stick coils securely.

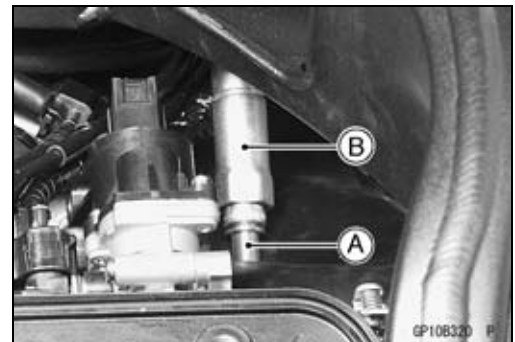

#### **Spark Plug Condition Inspection**

- Visually inspect the spark plugs.
- ★ If the spark plug center electrode [A] and/or side electrode [B] are corroded or damaged, or if the insulator [C] is cracked, replace the plug.
- ★ If the spark plug is dirtied or the carbon is accumulated, replace the spark plug.
- Measure the gap [D] with a wire-type thickness gauge.
- ★ If the gap is incorrect, replace the spark plug.

**Spark Plug Gap: 0.8 ~ 0.9 mm (0.032 ~ 0.035 in.)**

- Use the standard spark plug or its equivalent.

**Spark Plug: CR9EIA-9**

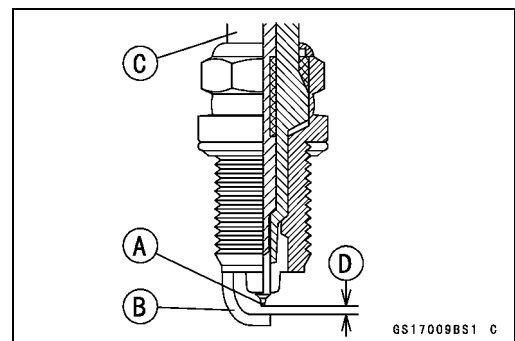

## 16-42 ELECTRICAL SYSTEM

### Ignition System

#### *Camshaft Position Sensor Removal*

- Remove:
  - Right Lower Fairing (see Frame chapter)
  - Right Middle Fairing (see Frame chapter)
  - Air Cleaner Housing (see Fuel System (DFI) chapter)
  - Left Air Duct [A] (see Fuel System (DFI) chapter)
  - Clamp [B]
  - Air Switching Valve Hose [C]
  
- Disconnect the connector [A] from the connector bracket.
- Insert the thin blade screw driver [B] into the connector stopper portion.
- Disconnect the camshaft position sensor lead connector.

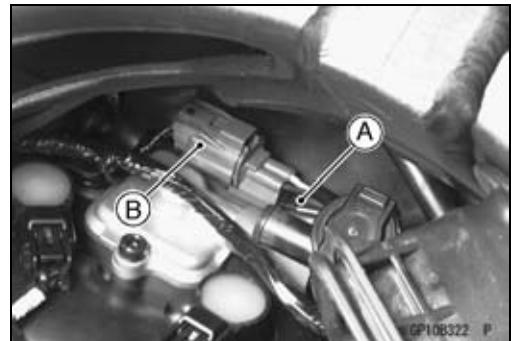
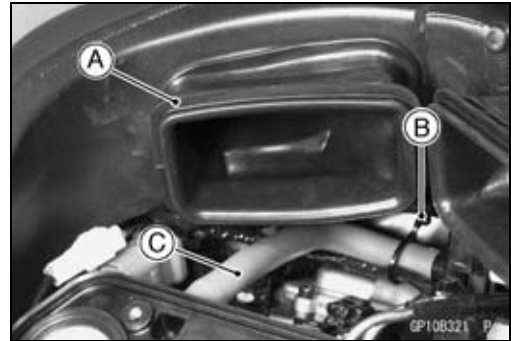

- Remove:
  - Camshaft Position Sensor Bolt [A]
  - Camshaft Position Sensor [B]

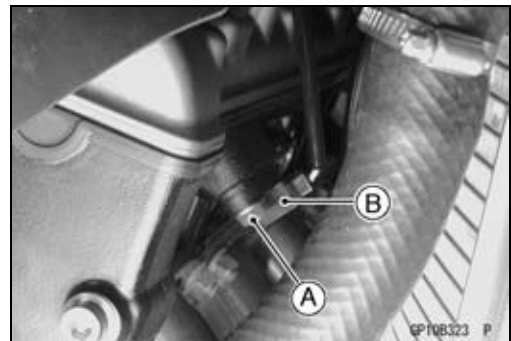

#### *Camshaft Position Sensor Installation*

- Apply grease or engine oil to the O-ring on the camshaft position sensor.
- Tighten:
  - Torque - Camshaft Position Sensor Bolt: 9.8 N·m (1.0 kgf·m, 87 in·lb)**

#### *Camshaft Position Sensor Inspection*

- Remove:
  - Camshaft Position Sensor Lead Connector [A] (see this chapter)



## Ignition System

- Set the hand tester to the  $\times 10 \Omega$  range and connect it to the terminals.

**Special Tool - Hand Tester: 57001-1394**

- ★ If there is more resistance than the specified value, the sensor coil has an open lead and must be replaced. Much less than this resistance means the sensor coil is shorted, and must be replaced.

**Camshaft Position Sensor Resistance: 400 ~ 460  $\Omega$**

- Using the highest resistance range of the tester, measure the resistance between the camshaft position sensor leads and chassis ground.
- ★ Any tester reading less than infinity ( $\infty$ ) indicates a short, necessitating replacement of the camshaft position sensor.

### Camshaft Position Sensor Peak Voltage Inspection

- Remove:  
Camshaft Position Sensor Lead Connector (see this chapter)
- Set the commercially available tester [A] to the 10 V DC range.
- Connect commercially available peak voltage adapter [B] to the hand tester and camshaft position sensor leads in the terminals.

**Special Tool - Peak Voltage Adapter: 57001-1415**  
**Type: KEK-54-9-B**

#### Connections:

Camshaft Position Sensor Terminal	Adapter	Hand Tester
Black [C]	← Red →	(+)
Yellow [D]	← Black →	(-)

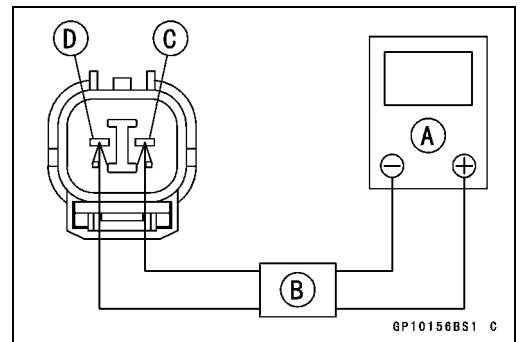
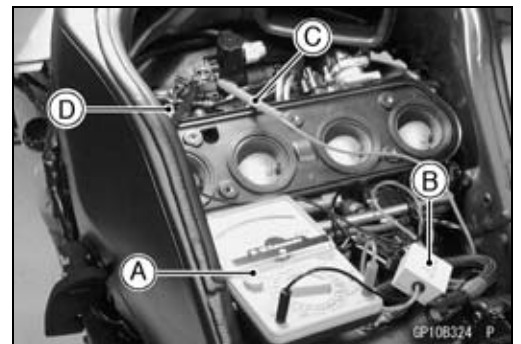
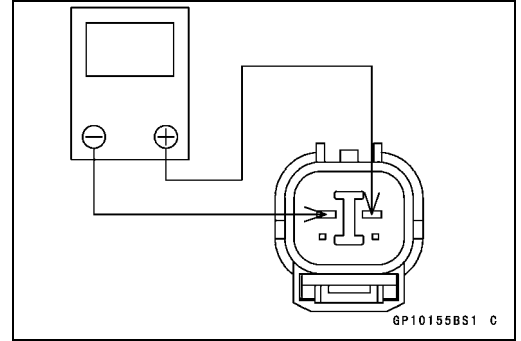

- Turn the ignition switch and engine stop switch on.
- Pushing the starter button, turn the engine 4 ~ 5 seconds with the transmission gear in neutral to measure the camshaft position sensor peak voltage.
- Repeat the measurement 5 or more times.

### Camshaft Position Sensor Peak Voltage

**Standard: 0.4 V or more**

- ★ If the peak voltage is lower than the standard, inspect the camshaft position sensor.

## 16-44 ELECTRICAL SYSTEM

### Ignition System

#### *Interlock Operation Inspection*

- Using the stand [A], raise the rear wheel off the ground.



#### **1st Check**

- Start the engine to the following conditions.

##### **Condition:**

**Transmission Gear → 1st Position**

**Clutch Lever → Release**

**Sidestand → Down or Up**

- Turn the ignition switch ON and push the starter button.
- Then the starter motor should not turn when the starter system circuit is normality.
- ★ If the engine is start, inspect the starter lockout switch, gear position switch, and relay box.
- ★ If their parts are normality replace the ECU.

#### **2nd Check**

- Start the engine to the following conditions.

##### **Condition:**

**Transmission Gear → 1st Position**

**Clutch Lever → Pulled in**

- Turn the ignition switch ON and push the starter button.
- Then the starter motor should turn when the starter system circuit is normality.
- ★ If the starter motor is not turn, inspect the starter lockout switch, gear position switch, and relay box.
- ★ If their parts are normality replace the ECU.

#### **3rd Check**

- Inspect the engine for its secure stop after the following operations are completed.
- Run the engine to the following conditions.

##### **Condition:**

**Transmission Gear → 1st Position**

**Clutch Lever → Release**

**Sidestand → Up**

- Set the side stand on the ground, then the engine will stop.
- ★ If whichever may not be stopped, inspect the gear position switch, starter lockout switch, sidestand switch and relay box.
- ★ If their parts are normality, replace the ECU.

Ignition System

IC Igniter Inspection

- The IC igniter is built in the ECU [A].
- Refer to the Interlock Operation Inspection, Ignition System Troubleshooting chart and Fuel System (DFI) chapter for ECU Inspection.

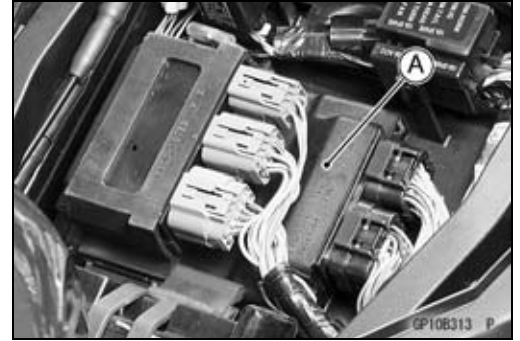

Ignition System Circuit

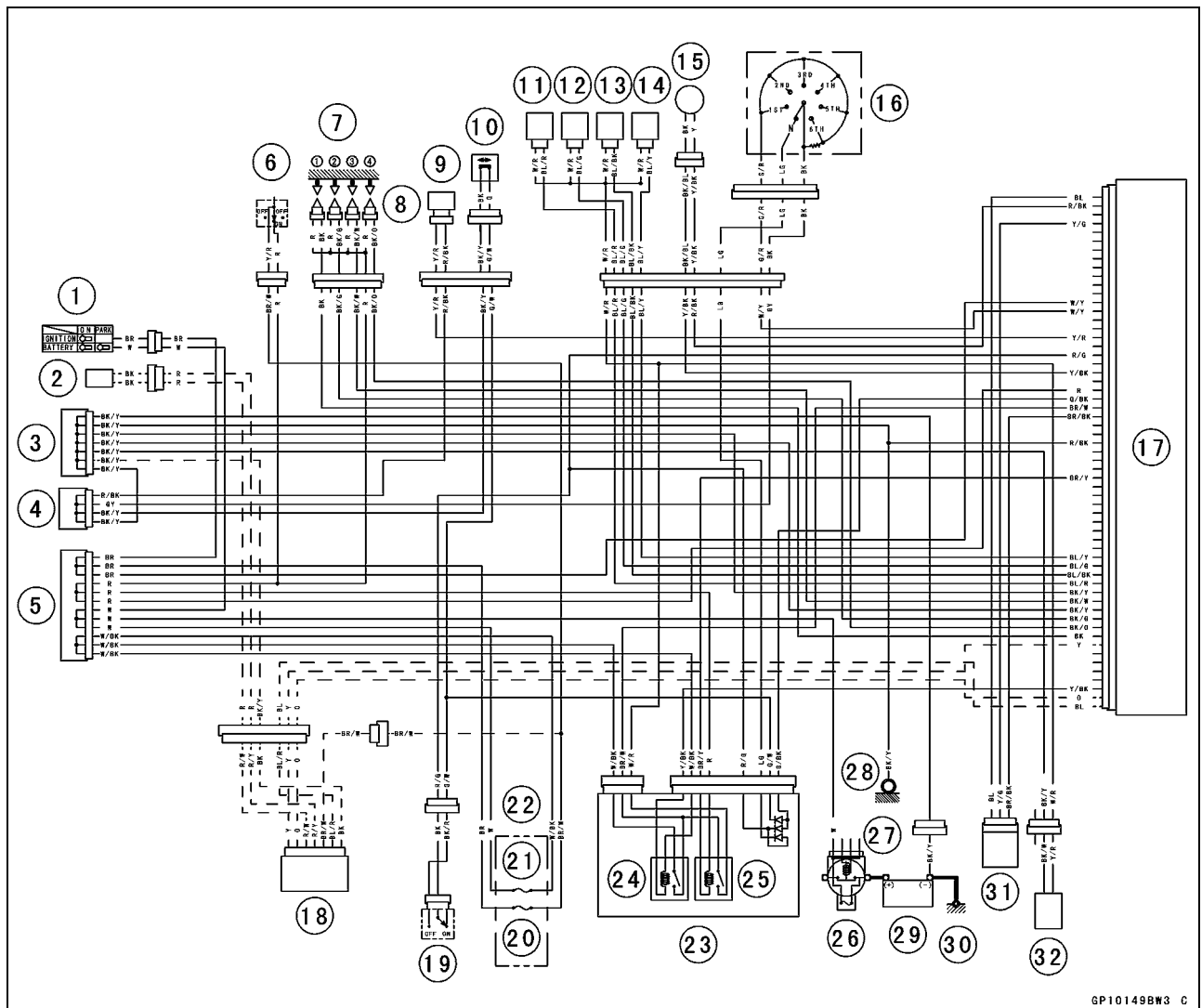

- |                             |                                 |                         |
|-----------------------------|---------------------------------|-------------------------|
| 1. Ignition Switch          | 12. Fuel Injector #2            | 23. Relay Box           |
| 2. Immobilizer Antenna      | 13. Fuel Injector #3            | 24. ECU Main Relay      |
| 3. Joint Connector 2        | 14. Fuel Injector #4            | 25. Fuel Pump Relay     |
| 4. Joint Connector 1        | 15. Crankshaft Sensor           | 26. Main Fuse 30 A      |
| 5. Joint Connector 4        | 16. Gear Position Switch        | 27. Starter Relay       |
| 6. Engine Stop Switch       | 17. ECU (Electric Control Unit) | 28. Frame Ground        |
| 7. Spark Plugs              | 18. Immobilizer Amplifier       | 29. Battery 12 V 10 Ah  |
| 8. Stick Coils              | 19. Starter Lockout Switch      | 30. Engine Ground       |
| 9. Camshaft Position Sensor | 20. Ignition Fuse 10 A          | 31. Vehicle-down-sensor |
| 10. Sidestand Switch        | 21. ECU Fuse 15 A               | 32. Fuel Pump           |
| 11. Fuel Injector #1        | 22. Fuse Box                    |                         |

## 16-46 ELECTRICAL SYSTEM

### Electric Starter System

#### Starter Idle Gear Removal

- Remove:
  - Lower Firing (see Frame chapter)
  - Idle Gear Cover Bolts [A]
  - Idle Gear Cover [B]
  - Rubber Damper [C]

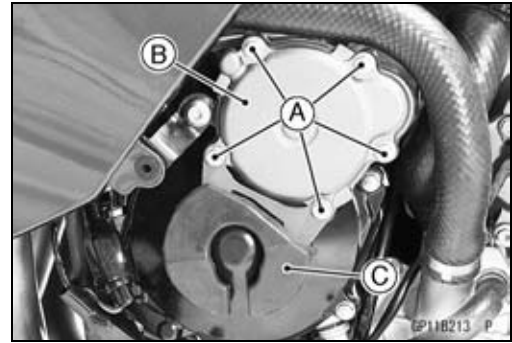

- Pull out the idle gear [A] with the spacer [B].

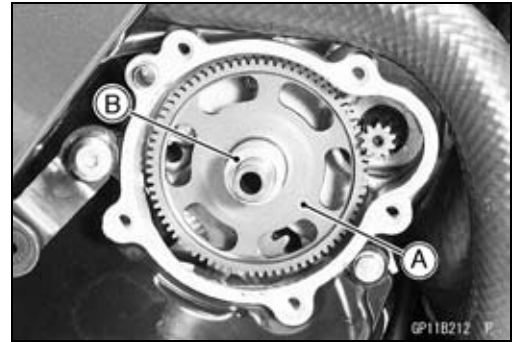

#### Starter Idle Gear Installation

- Apply molybdenum disulfide grease.
    - Idle Gear Shaft
  - Install:
    - Idle Gear [A]
    - Spacer [B]
    - Idle Gear Cover
- Torque - Idle Gear Cover Bolts: 9.8 N·m (1.0 kgf·m, 87 in·lb)**



#### Starter Clutch Removal

- Remove:
  - Idle Gear [A]
  - Right Middle Firing (see Frame chapter)
  - Starter Clutch Cover Bolts [A]
  - Starter Clutch Cover [B]
- Place a suitable container under the starter clutch cover.

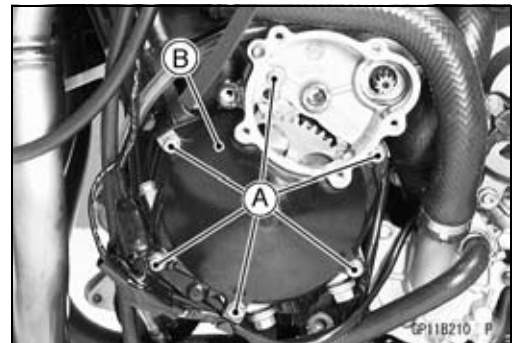

- Using the flywheel and pulley holder [A], unscrew the starter motor clutch bolt [B].

**Special Tool - Flywheel and Pulley Holder: 57001-1605**

- The starter clutch bolt has left-hand threads.
- Remove the starter clutch [C] with the starter clutch gear [D].
- Separate the clutch and gear.

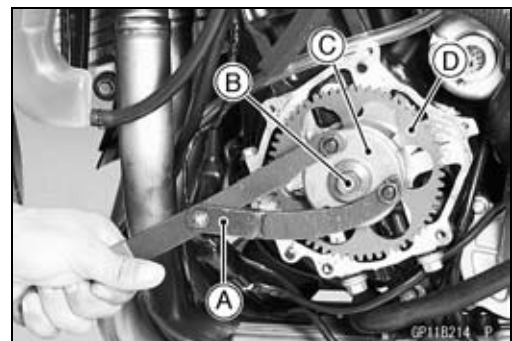



## Electric Starter System

### Starter Clutch Installation

- Install the starter gear [A] to the starter clutch [B].
- Turning the starter gear clockwise push in the starter gear as shown.

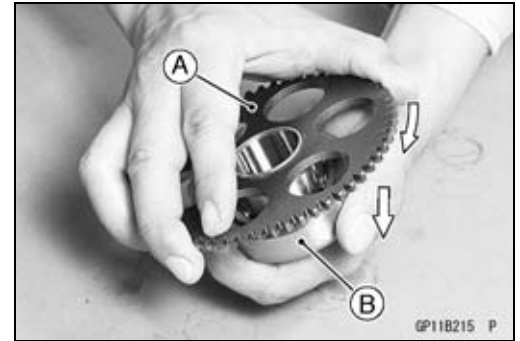

- Apply molybdenum disulfide oil.  
Outside of Bushing [A]
- Install the needle bearing [B] into the starter gear [C].

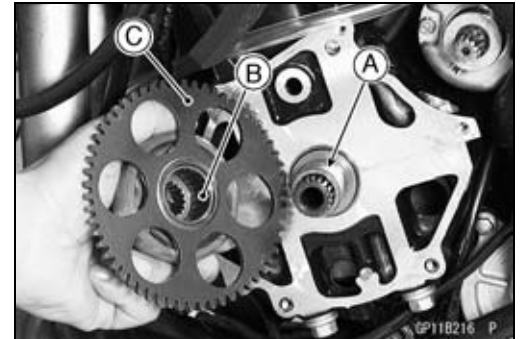

- Tighten the starter clutch bolt [A].
- The starter clutch bolt has left-hand threads.  
**Torque - Starter Clutch Bolt: 49 N·m (5.0 kgf·m, 36 ft·lb)**
- Apply silicone sealant.  
Crankcase Halves Mating Surface [B]
- Install the dowel pins [C].

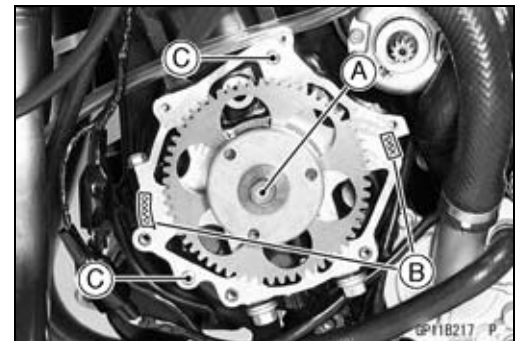

- Install:  
Starter Clutch Cover  
Starter Clutch Cover Bolts with Clamps [A]  
**Torque - Starter Clutch Cover Bolts: 9.8 N·m (1.0 kgf·m, 87 in·lb)**
- Install the other removed parts.

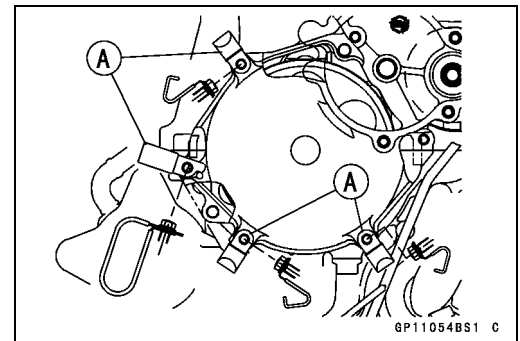

### Starter Clutch Disassembly

- Remove:  
Starter Clutch  
Snap Ring [A]
- Pull out the one-way clutch [B].

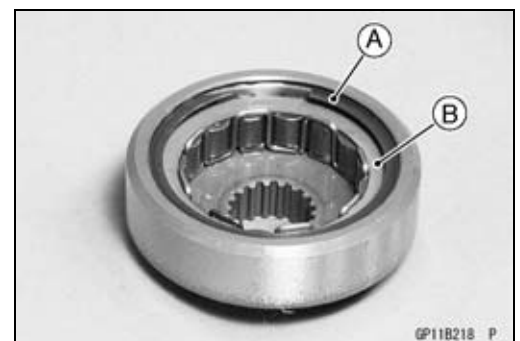

# 16-48 ELECTRICAL SYSTEM

## Electric Starter System

### Starter Clutch Assembly

- Install the one-way clutch [A] so that its circlip side faces [B] in.

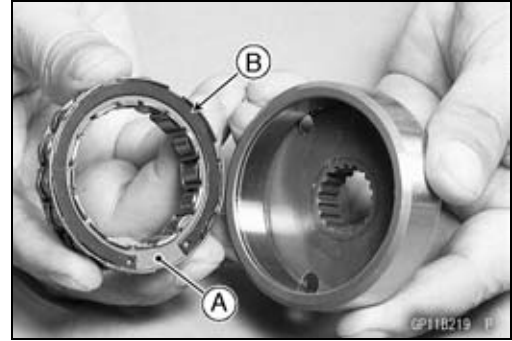

### Starter Clutch Inspection

- Remove the starter idle gear (see this chapter).
- Turn the starter idle gear [A] by hand. When viewed from the left side of the engine, the idle gear should turn counterclockwise freely [B], but should not turn clockwise (left side view).
- ★ If the starter clutch does not operate as it should or if it makes noise, go to the next step.



- Remove and disassemble the starter clutch (see this section), and visually inspect the clutch parts.  
One-way Clutch [A]  
Clutch Holder [B]
- If there is any worn or damaged part, replace it.

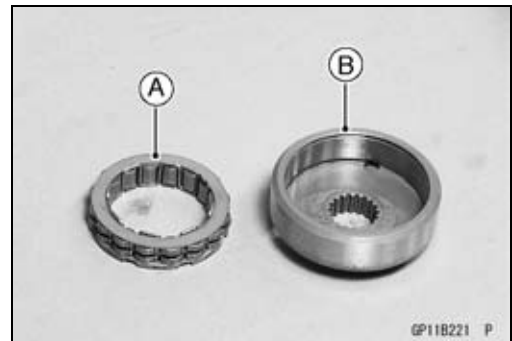

- Examine the starter clutch gear [C] as well. Replace the clutch gear if it is worn or damaged.



### Starter Motor Removal

- Remove:  
Right Lower Fairing (see Frame chapter)  
Right Middle Fairing (see Frame chapter)  
Starter Clutch Cover [A] (see Starter Clutch Cover Removal)  
Coolant Hoses [B] (see Cooling System chapter)



## Electric Starter System

- Remove:
  - Fuel Tank (see Fuel System (DFI) chapter)
  - Throttle Body Assy (see Fuel System (DFI) chapter)
  - Starter Motor Mounting Bolts [A]



- Slide back the rubber cap [A].
- Remove the starter motor cable terminal nut [B].
- Pull out the starter motor [C].

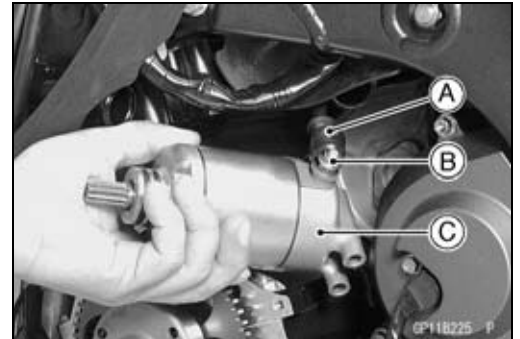

### Starter Motor Installation

#### CAUTION

**Do not tap the starter motor shaft or body. Tapping the shaft or body could damage the motor.**

- Clean the starter motor legs [A] and crankcase [B] where the starter motor is grounded.

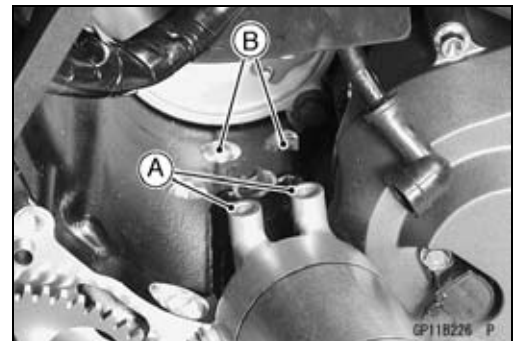

- Replace the O-rings [A] with new ones.
- Apply grease to the O-rings.
- Set the starter motor mounting bolts [C].
- Install the starter motor cable end and cap [B].

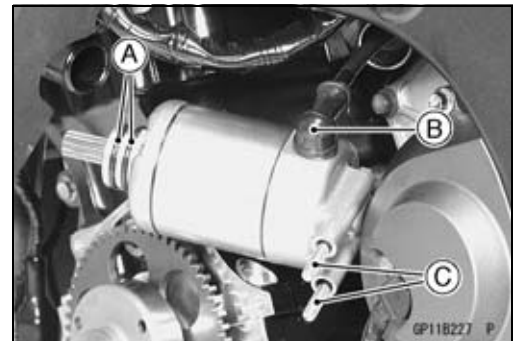

- Temporary tighten the mounting bolts.
- Install the starter clutch cover [A].
- Tighten:
  - Torque - Starter Motor Mounting Bolts: 9.8 N·m (1.0 kgf·m, 87 in·lb)

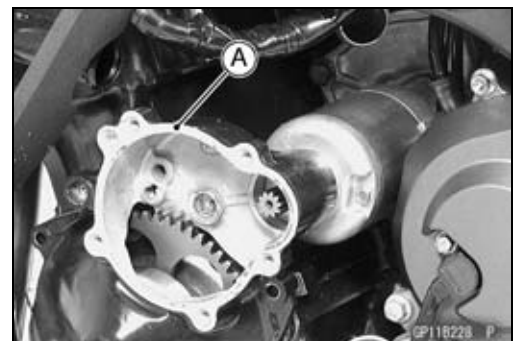

# 16-50 ELECTRICAL SYSTEM

## Electric Starter System

### Starter Motor Disassembly

- Take off the starter motor through bolts [A] and remove both end covers [B].

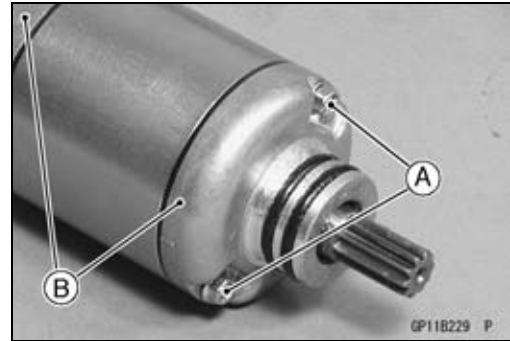

- Pull the armature [A] out of the yoke [B].

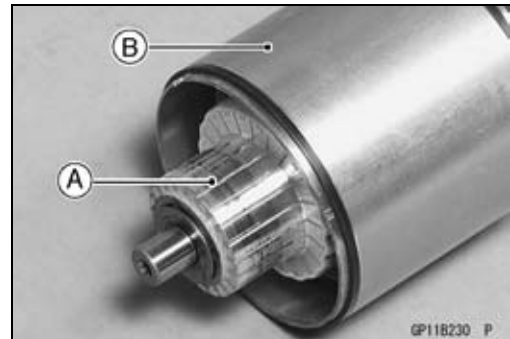

- Remove:
  - Brush Plate Terminal Nut [A]
  - Brush Plate Assembly [B]

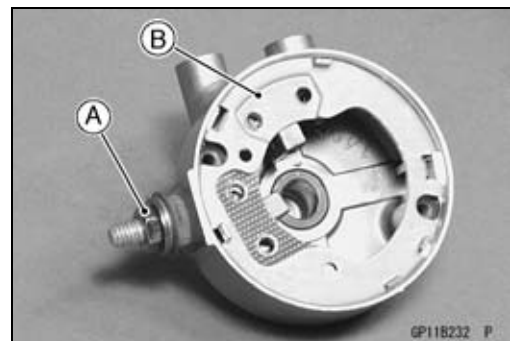

### Starter Motor Assembly

- Pry the spring end [A] and insert the brush [B].

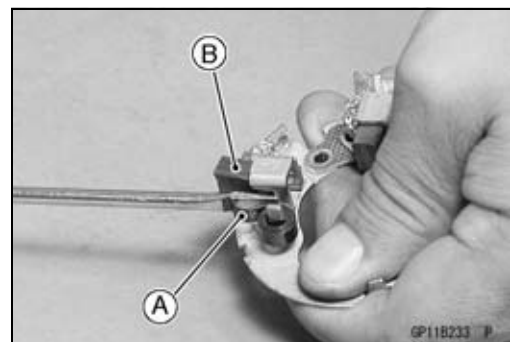

- Install the brush plate assembly [A] into the right-hand end cover [B].
- Replace the O-ring with a new one.
- Install:
  - O-ring [C]
  - Insulators [D]
  - Washer [E]
  - Terminal Nut [F]

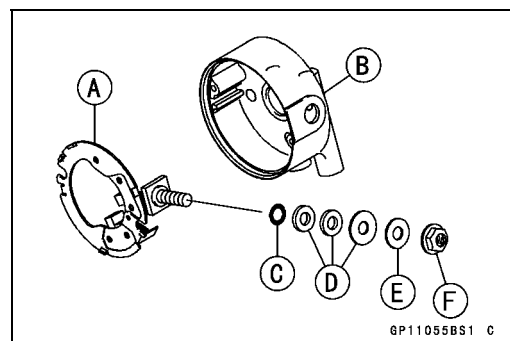

## Electric Starter System

- Install the armature [A] into the yoke [B].
- Install the slip [C] and thrust washers [D] onto each side of the shaft.

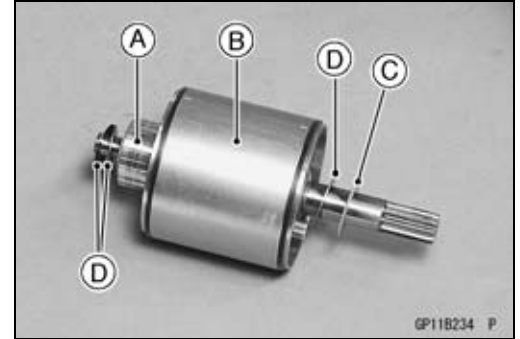

- Replace the O-ring with new ones.
- Install the O-rings [A].
- Put the armature among the brushes [B].

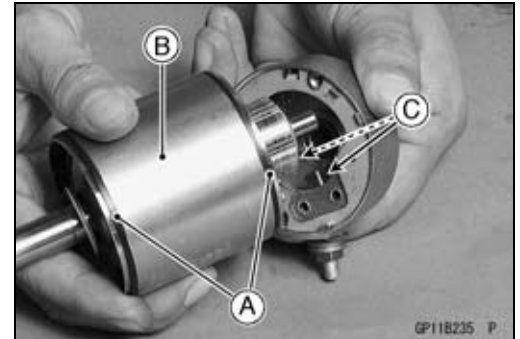

- Apply a thin coat of grease to the oil seal [A].
- Fit the toothed washer [B] into the left-hand end cover.

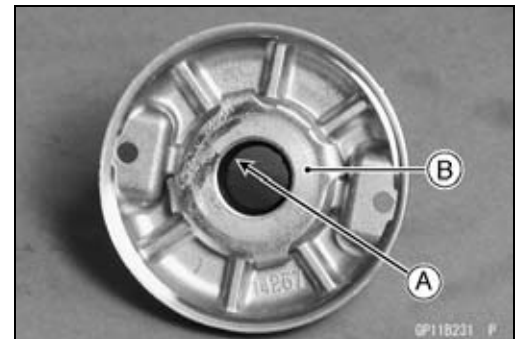

- Align the marks [A] to assembly the yoke and the end covers.

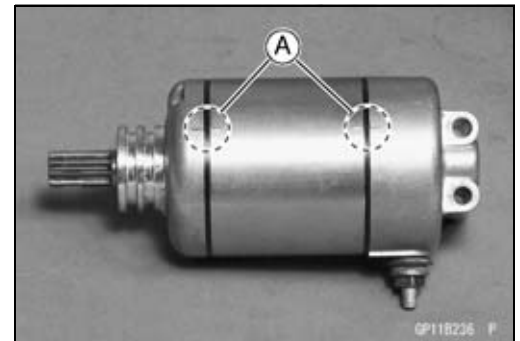

- Replace the O-rings [A] with new ones.
- Tighten:  
**Torque - Starter Motor Through Bolts [B]: 3.5 N·m (0.36 kgf·m, 31 in·lb)**

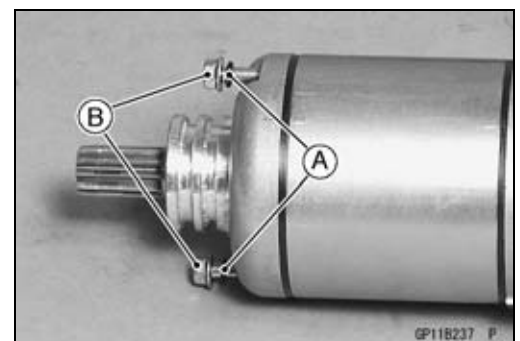

# 16-52 ELECTRICAL SYSTEM

## Electric Starter System

- Replace the O-rings with new ones.
- Apply grease to the O-rings.
- Install the O-rings [A].

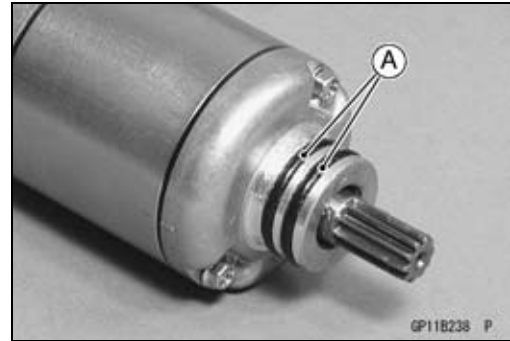

### Brush Inspection

- Measure the length [A] of each brush [B].
- ★ If any is worn down to the service limit, replace the brush holder assembly.

#### Starter Motor Brush Length

- Standard: 7 mm (0.28 in.)
- Service Limit: 3.5 mm (0.14 in.)

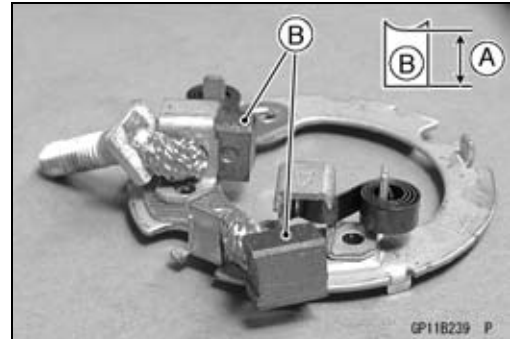

### Commutator Cleaning and Inspection

- Smooth the commutator surface [A] if necessary with fine emery cloth [B], and clean out the grooves.

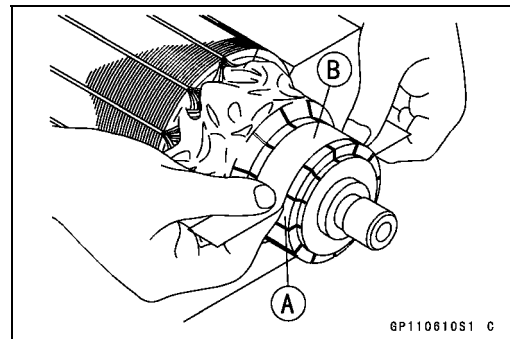

- Measure the diameter [A] of the commutator [B].
- ★ If the commutator diameter is less than the service limit, replace the starter motor with a new one .

#### Commutator Diameter

- Standard: 24 mm (0.94 in.)
- Service Limit: 23 mm (0.91 in.)

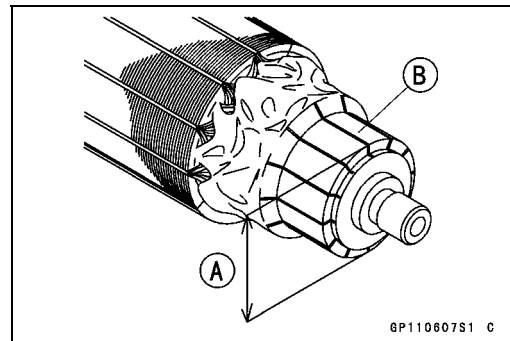

### Armature Inspection

- Using the  $\times 1 \Omega$  hand tester range, measure the resistance between any two commutator segments [A].

#### Special Tool - Hand Tester: 57001-1394

- ★ If there is a high resistance or no reading ( $\infty$ ) between any two segments, a winding is open and the starter motor must be replaced.
- Using the highest hand tester range, measure the resistance between the segments and the shaft [B].
- ★ If there is any reading at all, the armature has a short and the starter motor must be replaced.

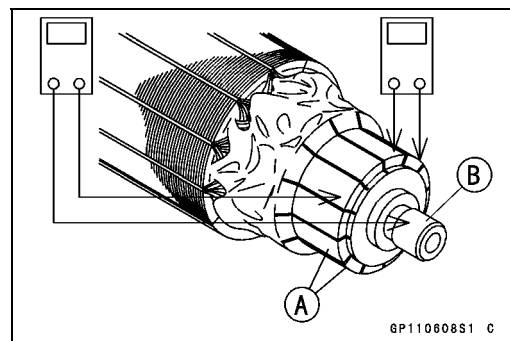

## Electric Starter System

### NOTE

○ Even if the foregoing checks show the armature to be good, it may be defective in some manner not readily detectable with the hand tester. If all other starter motor and starter motor circuit components check good, but the starter motor still does not turn over or only turns over weakly, replace the starter motor with a new one.

### Brush Lead Inspection

- Using the  $\times 1 \Omega$  hand tester range, measure the resistance as shown.

[A] Terminal Bolt and Positive Brush

[B] Right-hand End Cover and Negative Brush

**Special Tool - Hand Tester: 57001-1394**

- ★ If there is not close to zero ohms, the brush lead has an open. Replace the positive brush assembly and/or the negative brush subassembly.

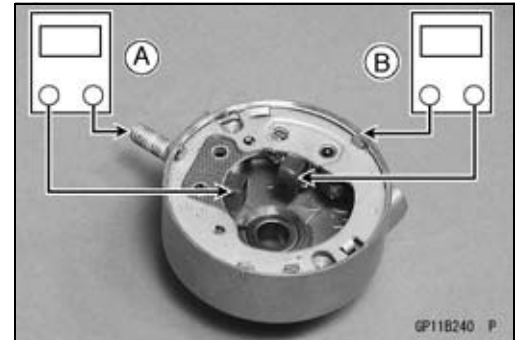

### Right-hand End Cover Assembly Inspection

- Using the highest hand tester range, measure the resistance as shown.

[A] Terminal and Right-hand End Cover

**Special Tool - Hand Tester: 57001-1394**

- ★ If there is any reading, the right-hand end cover assembly have a short. Replace the right-hand end cover assembly.

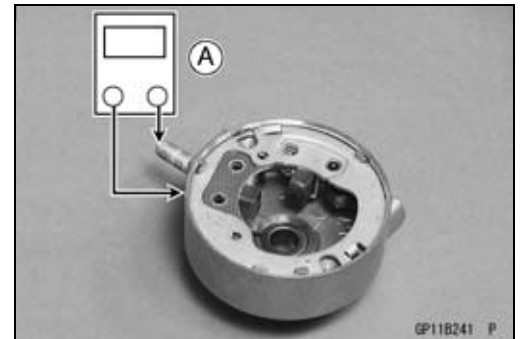

### Starter Relay Inspection

- Remove:
  - Seats (see Frame chapter)
  - Fuel Tank (see Fuel System (DFI) chapter)
  - Ground Cable (Battery Terminal)
  - Clamp
  - Starter Cable [A]
  - Battery Cable [B]
  - Connector [C]
  - Starter Relay [D]

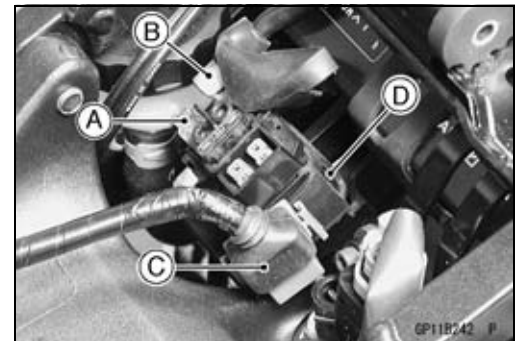

- Connect the hand tester [A] and 12 V battery [B] to the starter relay [C] as shown.

**Special Tool - Hand Tester: 57001-1394**

- ★ If the relay does not work as specified, the relay is defective. Replace the relay.

### Testing Relay

**Tester Range:**  $\times 1 \Omega$  range

**Criteria:** When battery is connected  $\rightarrow 0 \Omega$

When battery is disconnected  $\rightarrow \infty \Omega$

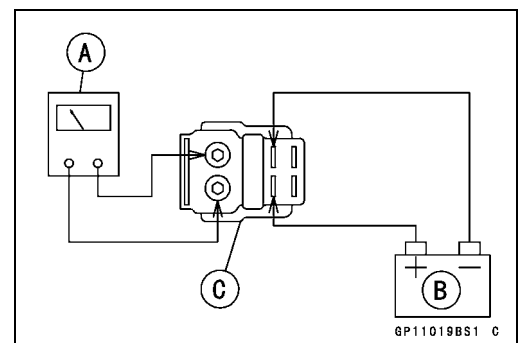

# 16-54 ELECTRICAL SYSTEM

## Electric Starter System

### Electric Starter Circuit

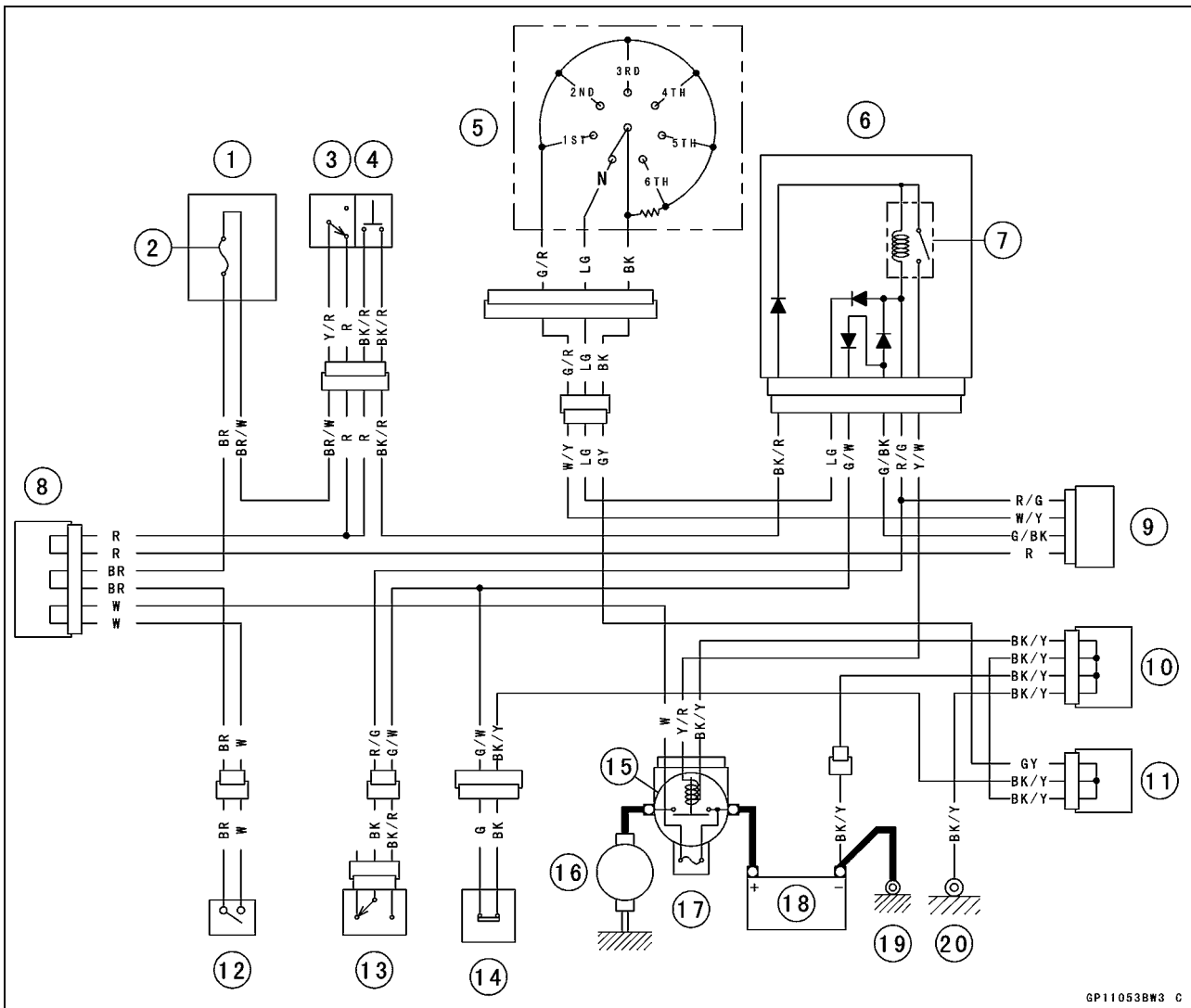

GP11053BW3 C

- |                          |                            |
|--------------------------|----------------------------|
| 1. Fuse Box              | 11. Joint Connector 1      |
| 2. Ignition Fuse 10 A    | 12. Ignition Switch        |
| 3. Engine Stop Switch    | 13. Starter Lockout Switch |
| 4. Starter Button        | 14. Side Stand Switch      |
| 5. Gear Position Switch  | 15. Starter Relay          |
| 6. Relay Box             | 16. Starter Motor          |
| 7. Starter Circuit Relay | 17. Main Fuse 30 A         |
| 8. Joint Connector 4     | 18. Battery 12 V 10 Ah     |
| 9. ECU                   | 19. Engine Ground          |
| 10. Joint Connector 2    | 20. Frame Ground           |



## Lighting System

This motorcycle adopt the daylight system and have a headlight relay in the relay box. The headlight does not go on when the ignition switch and the engine stop switch are first turned on. The headlight comes on after the starter button is released and stays on until the ignition switch is turned off. The headlight will go out momentarily whenever the starter button is pressed and come back on when the button is released.

### *Headlight Beam Horizontal Vertical Adjustment*

- Refer to the Headlight Aiming Inspection in the Periodic Maintenance chapter.

### *Headlight Beam Vertical Adjustment*

- Refer to the Headlight Aiming Inspection in the Periodic Maintenance chapter.

### *Headlight Bulb Replacement*

- Turn the dust cover [A] counterclockwise [B].

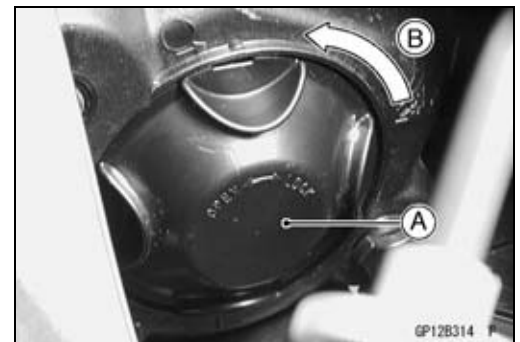

- Remove:
  - Headlight Connector [A]
  - Hook [B]
  - Headlight Bulb [C]

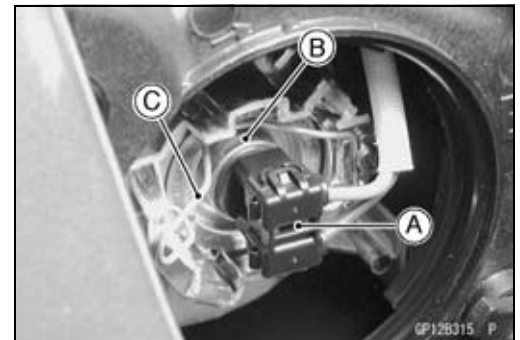

### CAUTION

**When handling the quartz-halogen bulb, never touch the glass portion with bare hands. Always use a clean cloth. Oil contamination from hands or dirty rags can reduce bulb life or cause the bulb to explode.**

### NOTE

○Clean off any contamination that inadvertently gets on the bulb with alcohol or soap and water solution.

- Replace the headlight bulb.
- Fit the projection [A] of the bulb in the hollow [B] of the headlight.

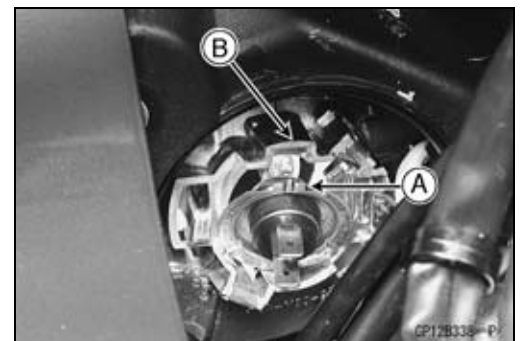

# 16-56 ELECTRICAL SYSTEM

## Lighting System

- Align the mark [A] on the headlight and mark [B] the dust cover, and turn the dust cover clockwise so that the mark of the dust cover is aligned with the mark [C] of the headlight.
- After installation, adjust the headlight aim (see Periodic Maintenance chapter).

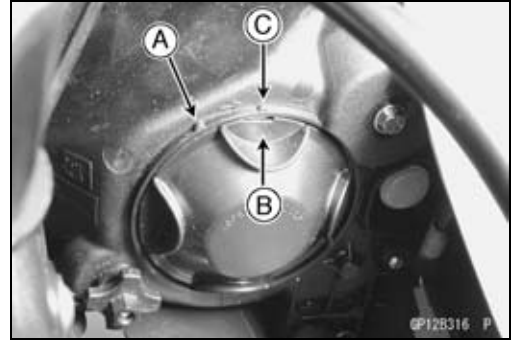

### City Light Bulb Replacement

- Remove:
  - Upper Inner Cover (see Frame chapter)
- Turn the socket [A] counterclockwise and pull out the socket together with the bulb.

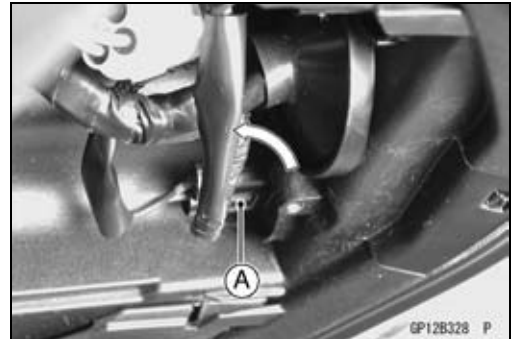

- Pull the bulb [A] out of the socket [B].

### CAUTION

Do not turn the bulb. Pull the bulb out to prevent damage to the bulb. Do not use bulb rated for greater wattage than the specified value.

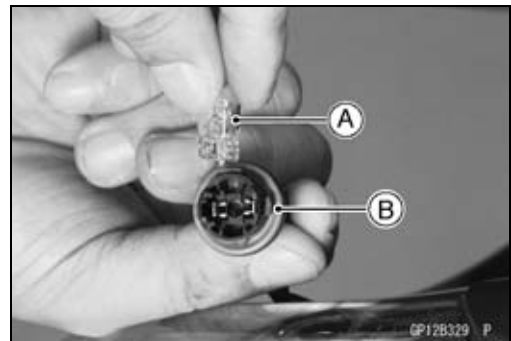

- Pushing the socket and turn it clockwise.
- Fit the projections [A] of the socket into the grooves [B] of the headlight.



### Headlight Removal/Installation

- Disassemble:
  - Upper Fairing (see Frame chapter)
- Remove:
  - Bolts [A]
- Refer to the Upper Fairing Assembly in the Frame chapter.

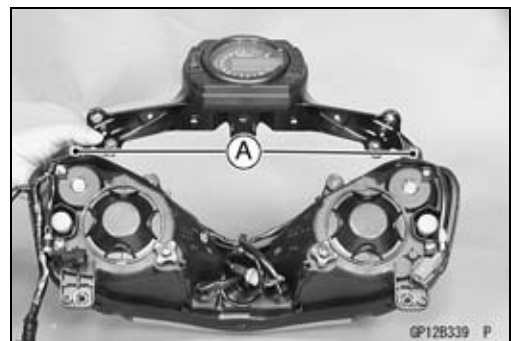

## Lighting System

### *Tail/Brake Light (LED) Removal*

- Remove:
  - Rear Seat (see Frame chapter)
  - Upper Seat Cover (see Frame chapter)
  - Seat Cover (see Frame chapter)
- Unscrew the mounting bolt [A].
- Remove the tail/brake light (LED) [B].

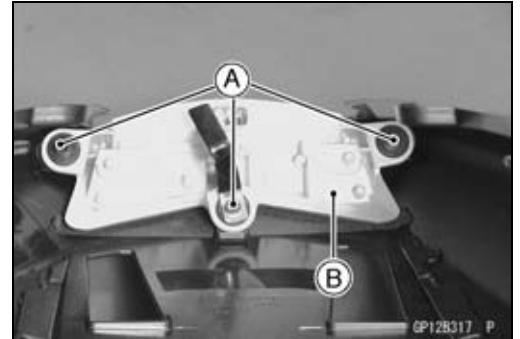

### *Tail/Brake Light (LED) Installation*

- Refer to the Seat Cover Installation in the Frame chapter.

### *License Plate Light Bulb Replacement*

- Remove:
  - Screws [A]
  - License Plate Light Cover [B]
  - Bulb
- Insert the new bulb [A] by aligning its upper and lower pins [B] with the upper and lower grooves [C] in the socket, and turn the bulb clockwise.
- Turn the bulb about 15° degrees.

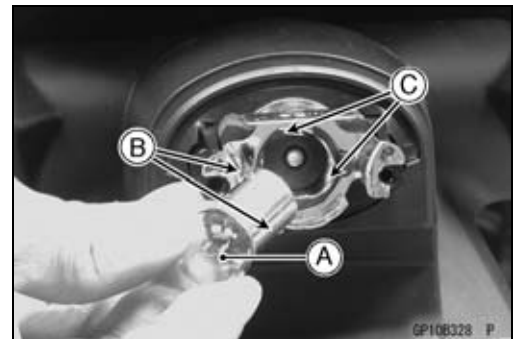
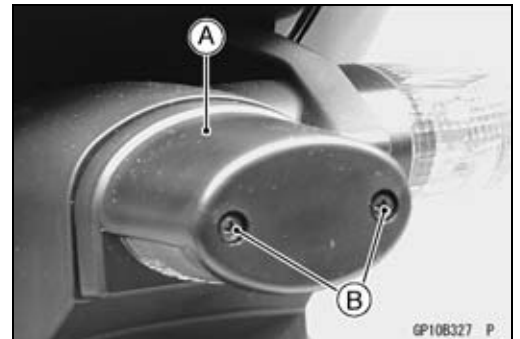

# 16-58 ELECTRICAL SYSTEM

## Lighting System

### Headlight/Tail Light Circuit

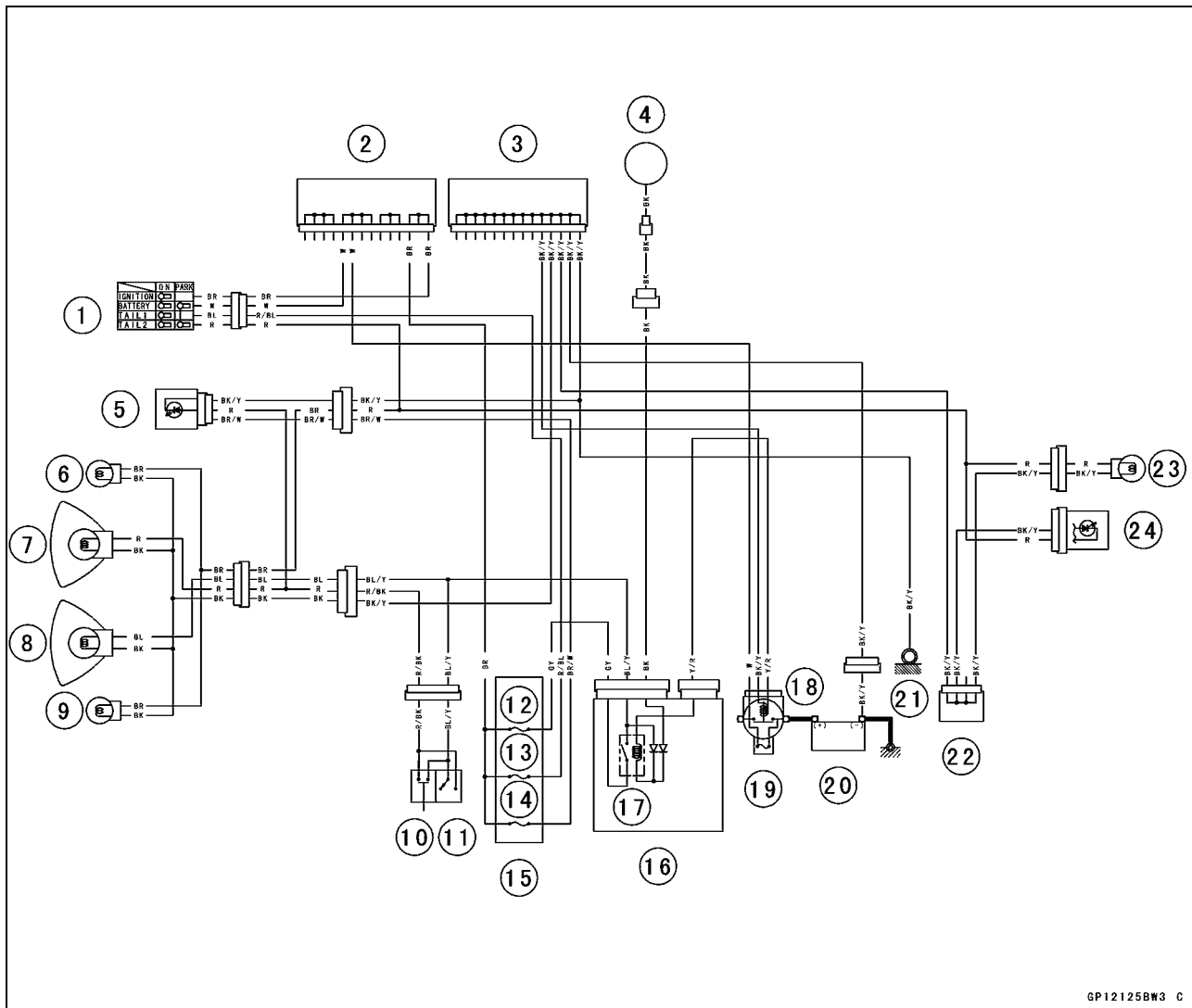

GP121258W3 C

- |                                    |                            |
|------------------------------------|----------------------------|
| 1. Ignition Switch                 | 13. Tail Light Fuse 10 A   |
| 2. Joint Connector 4               | 14. Ignition Fuse 10 A     |
| 3. Joint Connector 2               | 15. Fuse Box               |
| 4. Alternator                      | 16. Relay Box              |
| 5. High Beam Indicator Light (LED) | 17. Headlight Relay        |
| 6. Right City Light                | 18. Starter Relay          |
| 7. Headlight (High Beam)           | 19. Main Fuse 30 A         |
| 8. Headlight (Low Beam)            | 20. Battery 12 V 10 Ah     |
| 9. Left City Light                 | 21. Frame Ground           |
| 10. Passing Button                 | 22. Joint Connector 3      |
| 11. Dimmer Switch                  | 23. License Plate Light    |
| 12. Headlight Fuse 10 A            | 24. Tail/Brake Light (LED) |

## Lighting System

### Turn Signal Light Bulb Replacement Europe, Malaysia and Australia Models

- Remove:
  - Lower Fairing (see Frame chapter)
  - Middle Fairing (see Frame chapter)
- Unscrew the screws [A] and remove the front turn signal lens [B].
- Push and turn the bulb counterclockwise and remove it.

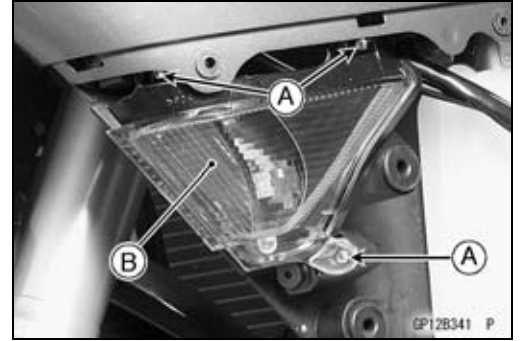

- Unscrew:
  - Screw [A]
- Remove:
  - Turn Signal Light [B]

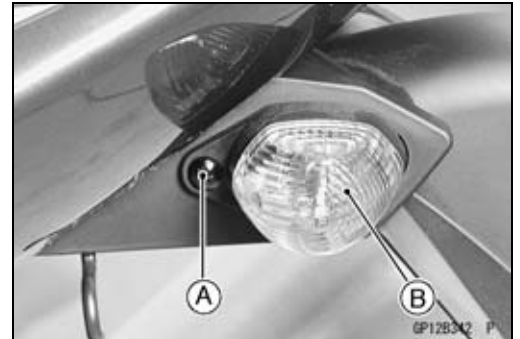

- Unscrew the screw [A] and removed the signal lens [B].
- Push and turn the bulb counterclockwise and remove it.

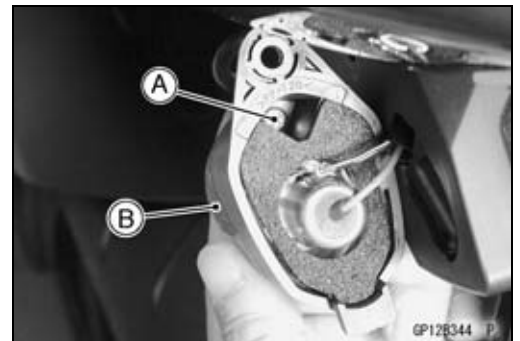

- Insert the new bulb [A] by aligning its upper and lower pins [B] with the upper and lower grooves [C] in the socket, and turn the bulb clockwise.
- Turn the bulb about 15° degrees.

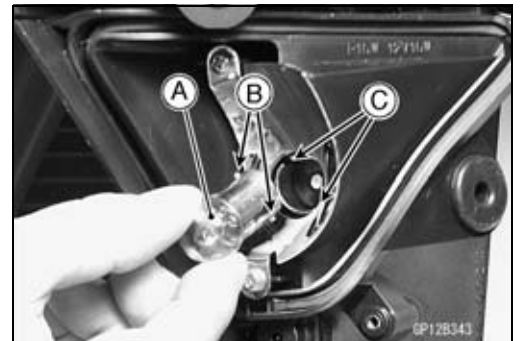

### United States and Canada Models

- Unscrew the screw [A].

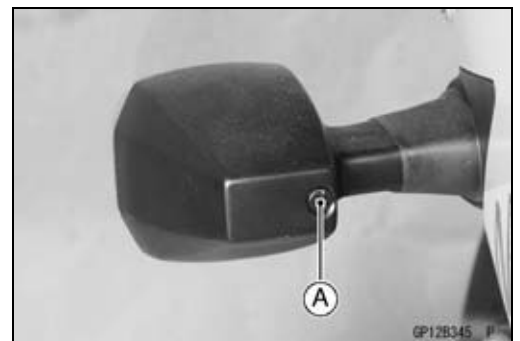

# 16-60 ELECTRICAL SYSTEM

## Lighting System

- Unscrew the screws [A] and remove the turn signal lens [B].
- Push and turn the bulb counterclockwise and remove it.

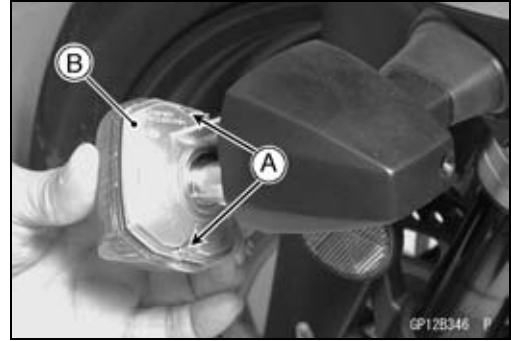

- Insert the new bulb [A] by aligning its upper and lower pins [B] with the upper and lower grooves [C] in the socket, and turn the bulb clockwise.

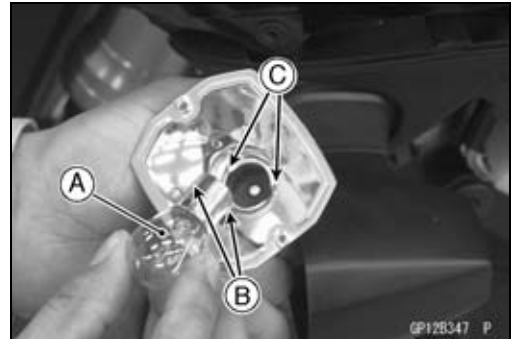

### Turn Signal Relay Inspection

- Remove:
    - Seats (see Frame chapter)
    - Turn Signal Relay [A]
  - Disconnect the connectors.
- Connect one 12 V battery and turn signal lights as indicated in the figure, and count how many times the lights flash for one minute.
- Turn Signal Relay [A]
  - Turn Signal Lights [B]
  - 12 V Battery [C]
- ★ If the lights do not flash as specified, replace the turn signal relay.

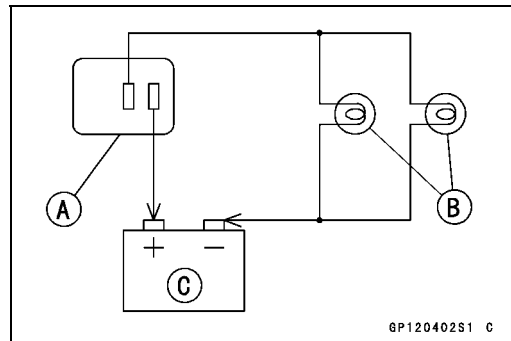
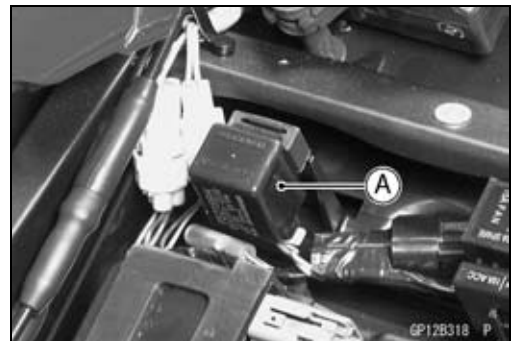

### Testing Turn Signal Relay

Load		Flashing Times (c/m*)
The Number of Turn Signal Lights	Wattage (W)	
1**	21	140-250
2	42	75-95

\*: Cycle(s) per minute

\*\* : Correspond to "one light burned out"

## Lighting System

## Turn Signal Light Circuit

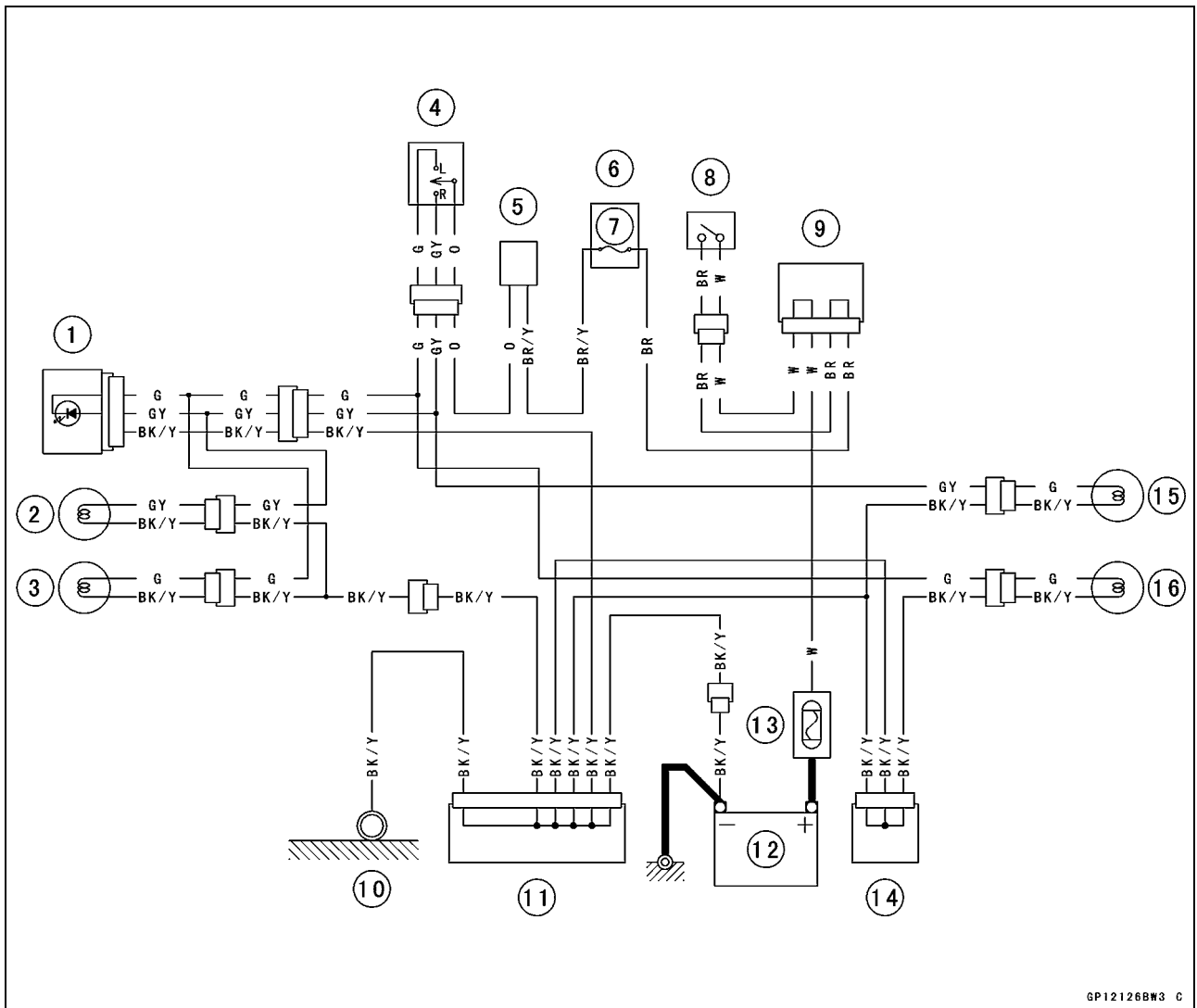

GP12126BW3 C

1. Turn Signal Indicator Lights (Right and Left)
2. Front Right Turn Signal Light
3. Front Left Turn Signal Light
4. Turn Signal Switch
5. Turn Signal Relay
6. Fuse Box
7. Turn Signal Relay Fuse 10 A
8. Ignition Switch
9. Joint Connector 4
10. Frame Ground
11. Joint Connector 2
12. Battery
13. Main Fuse 30 A
14. Joint Connector 3
15. Rear Right Turn Signal Light
16. Rear Left Turn Signal Light

# 16-62 ELECTRICAL SYSTEM

## Air Switching Valve

### Air Switching Valve Operation Test

- Remove:
  - Fuel Tank (see Fuel System (DFI) chapter)
  - Air Cleaner Housing (see Fuel System (DFI) chapter)
- Pull the air switching valve hose [A] out of the air cleaner base.

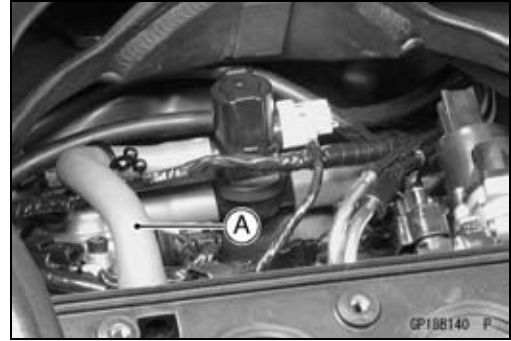

- Take the air switching valve hose end outside of the frame.
- Reinstall the fuel tank (see Fuel System (DFI) chapter).
- Start the engine and run it at idle speed.
- Plug [A] the air switching valve hose [B] end with your finger and feel vacuum pulsing in the hose.
- ★ If there is no vacuum pulsation, check the hose line for leak. If there is no leak, check the air switching valve (see Air Switching Valve Unit Test).
- Apply a soap and water solution or rubber lubricant to the end of the air switching hose and install the hose on the fitting.

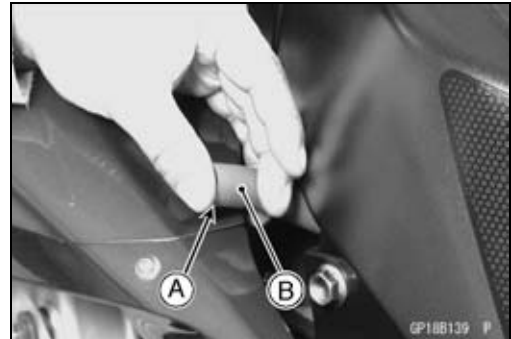

### Air Switching Valve Unit Test

- Remove the air switching valve (see Engine Top End chapter).
- Set the hand tester [A] to the  $\times \Omega$  range and connect it to the air switching valve terminals as shown.

**Special Tool - Hand Tester: 57001-1394**

#### Air Switching Valve Resistance

**Standard: 18 ~ 22  $\Omega$  at 20°C (68°F)**

- ★ If the resistance reading is except the specified value, replace it with a new one.
- Connect the 12 V battery [A] to the air switching valve terminals as shown.

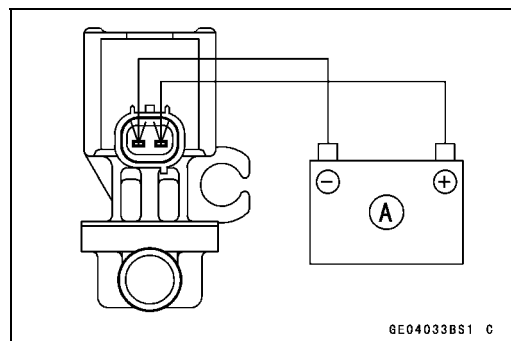
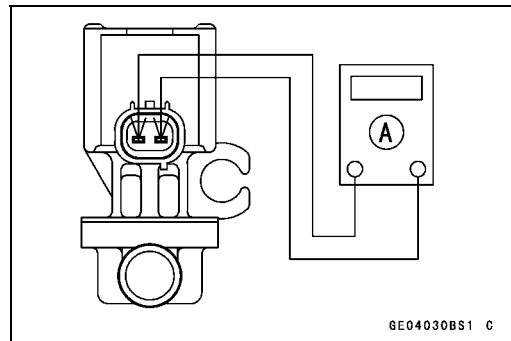



## Air Switching Valve

- Blow the air to the inlet air duct [A], and make sure does not flow the blown air from the outlet air ducts [B].

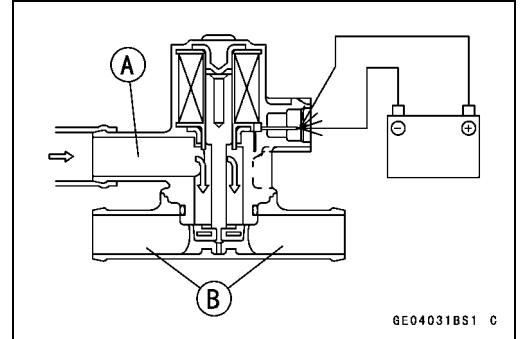

- Disconnect the 12 V battery.
  - Blow the air to the inlet air duct [A] again, and make sure flow the blown air from the outlet air ducts [B].
- ★ If the air switching valve does not operate as described, replace it with a new one.

### NOTE

- To check air flow through the air switching valve, just blow through the air cleaner hose [C].

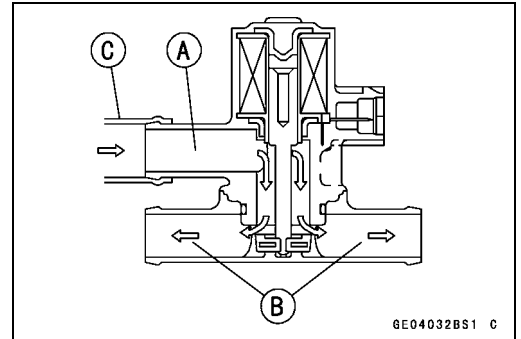

# 16-64 ELECTRICAL SYSTEM

## Radiator Fan System

### Fan Motor Inspection

- Open the clamp [A].
- Disconnect the connector [B].
- Using an auxiliary leads, supply battery power to the fan motor.
- ★ If the fan does not rotate, the fan motor is defective and must be replaced.

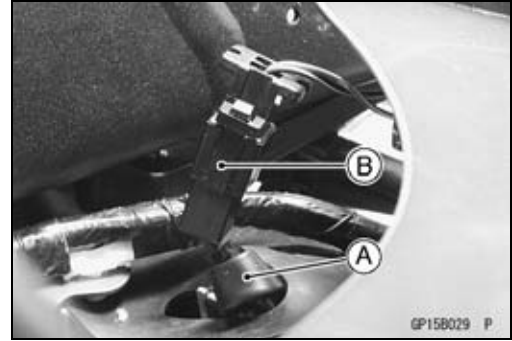

### Radiator Fan Circuit

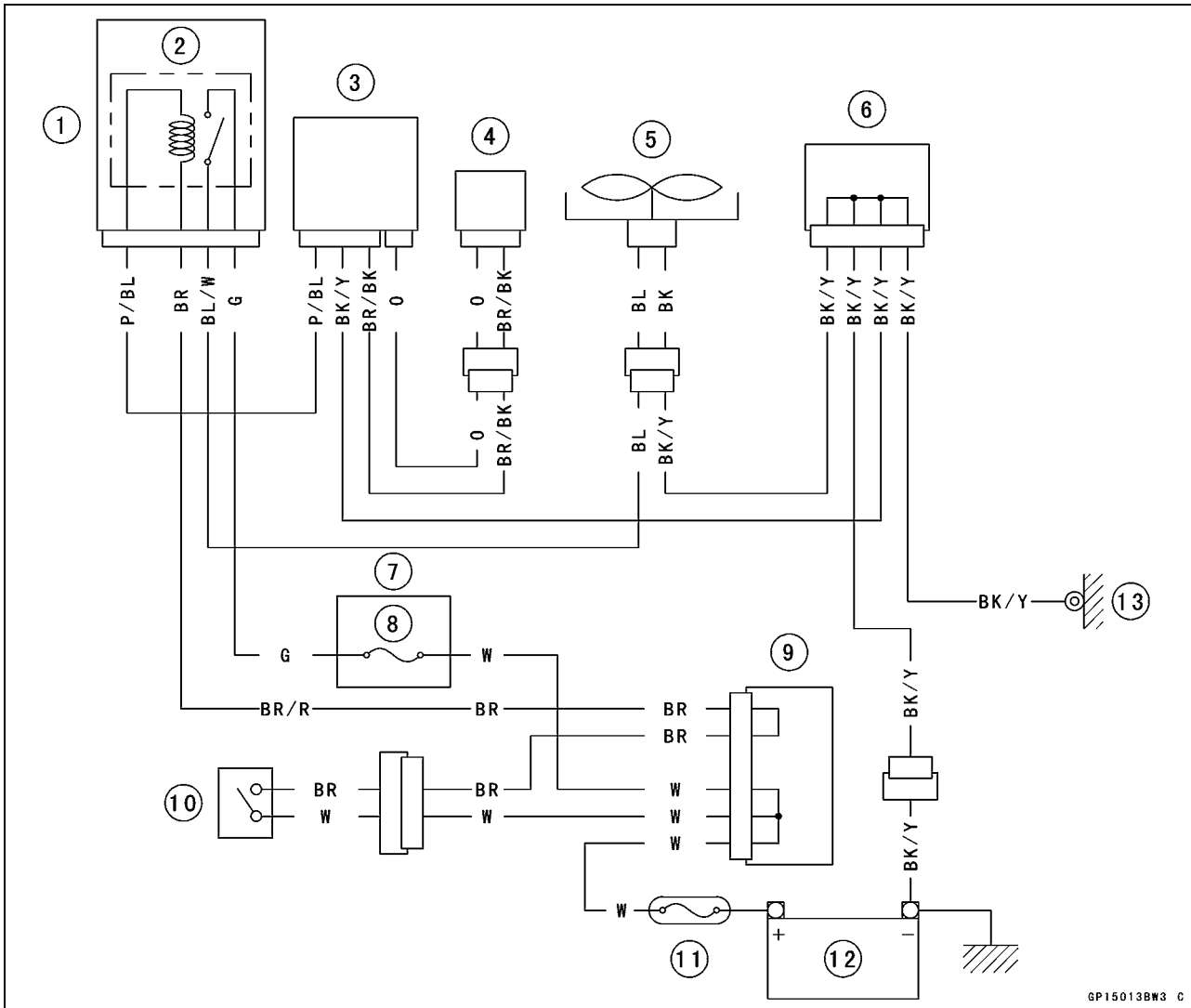

1. Relay Box
2. Radiator Fan Relay
3. Electronic Control Unit
4. Water Temperature Sensor
5. Radiator Fan
6. Joint Connector 4
7. Fuse Box

8. Fan Fuse 10 A
9. Joint Connector 2
10. Ignition Switch
11. Main Fuse 30 A
12. Battery 12 V 10 Ah
13. Frame Ground

## Meter, Gauge, Indicator Unit

### Meter Unit Removal

- Remove:
  - Upper Fairing (see Frame chapter)
- Slide the dust cover [A] and remove the wiring connector.

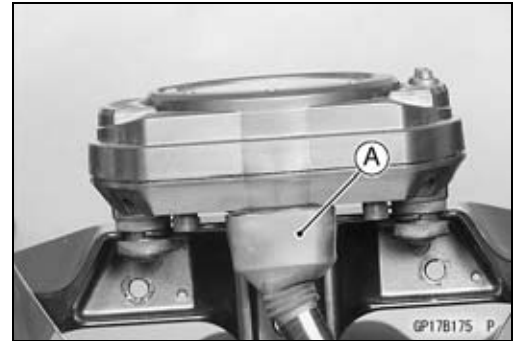

- Remove the meter unit by taking off the mounting screws [A] with the washers.

### CAUTION

Place the meter unit so that the face is up. If a meter unit is left upside down or sideways for any length of time, it will malfunction.

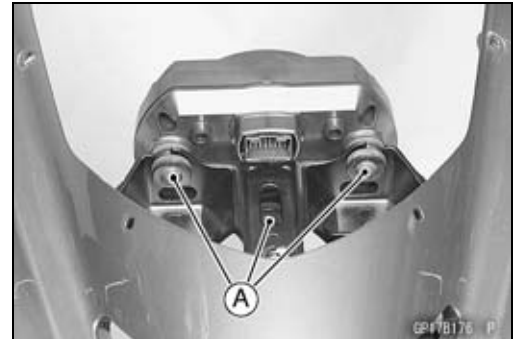

### Meter Unit Disassembly

- Remove:
  - Meter Unit (see Meter Unit Removal)
  - Screws [A]
  - Lower Meter Cover [B]

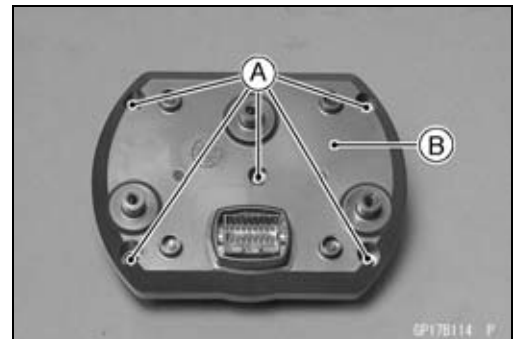

- Separate the meter liquid crystal display assembly [A] and upper meter cover [B].

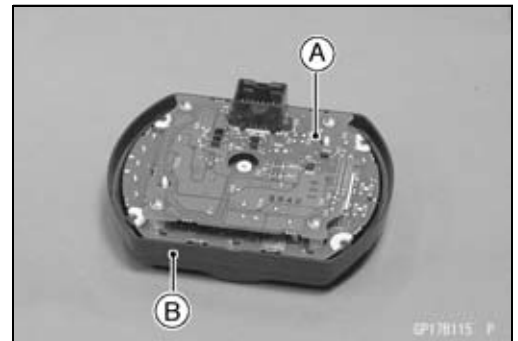

# 16-66 ELECTRICAL SYSTEM

## Meter, Gauge, Indicator Unit

### Electronic Combination Meter Assembly Inspection

- Remove the meter assembly [A].
  - [1] Ignition
  - [2] Fuel Reserve Switch
  - [3] Stop Watch (+)
  - [4] Lap Time (+)
  - [5] Neutral Indicator Light (LED) Ground (-)
  - [6] FI Indicator Light (LED) Ground (-)
  - [7] Tachometer Pulse
  - [8] Water Temperature Sensor
  - [9] Ground (-)
  - [10] Battery (+)
  - [11] Oil Pressure Warning Indicator Light (LED) Ground (-)
  - [12] Speed Sensor Supply Voltage
  - [13] Right Turn Signal Light (LED) (+)
  - [14] Left Turn Signal Indicator Light (LED) (+)
  - [15] High Beam Indicator Light (LED)
  - [16] Speed Sensor Pulse

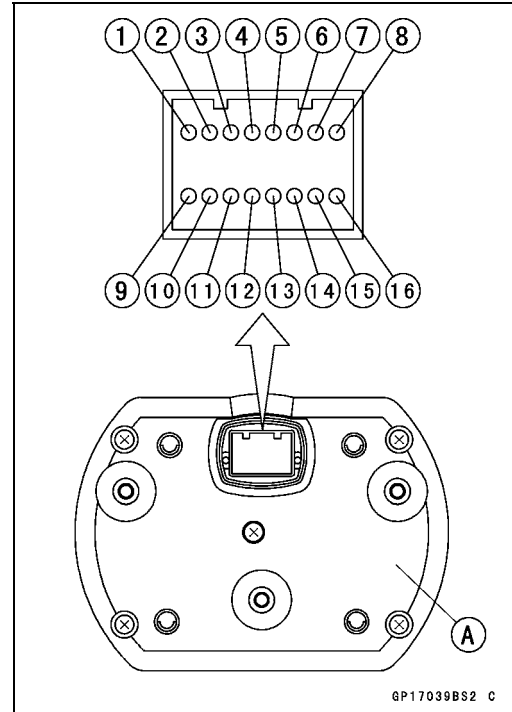

### CAUTION

Do not drop the meter unit. Place the meter unit so that it faces upward. If the meter assembly is left upside down or sideways for a long time or dropped, it will malfunction.

### CAUTION

Do not short each terminals.

### Liquid Crystal Display (LCD) Segments Check

- Connect the harness adapter to the meter assembly connector.

**Special Tool - Harness Adapter: 57001-1542**

- Using the auxiliary wires, connect the 12 V battery to the each connector of harness adapter as follows.
  - Connect the battery positive terminal to the terminal [10].
  - Connect the battery negative terminal to the terminal [9].

- Connect the terminal [1] to the terminal [10].

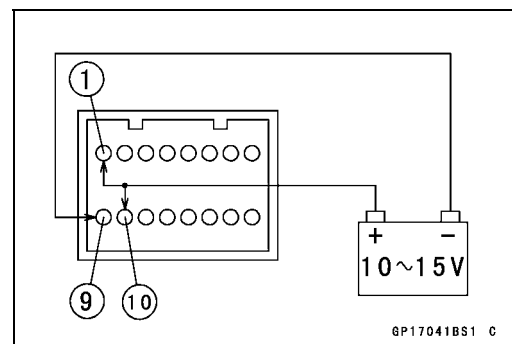
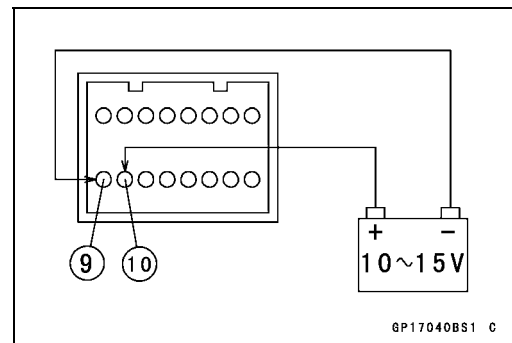

## Meter, Gauge, Indicator Unit

- The tachometer LCD segments momentarily to it last readings two times and segment movement is reversal.
- When the terminals are connected, all the LCD segments [A] and LED warning light [B] appear for three seconds.
- ★If the LCD segments and LED warning light will not appear, replace the meter assembly.
- Disconnect the terminal [1].
- All the LCD segments and LED warning light disappear.
- ★If the segments do not disappear, replace the meter assembly.

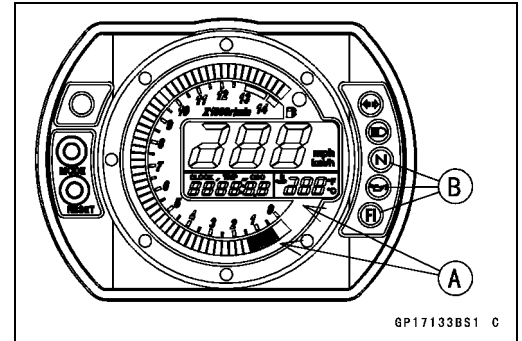

### MODE AND RESET BUTTON Operation Check

- Connect the 12 V battery and terminals in the same manner as specified in the "Liquid Crystal Display (LCD) Segments Check".
- Check that the display [B] change to the ODO, TRIP, and CLOCK and STOP WATCH displays each time the mode selector button [A] is pressed.
- If the fuel level warning indicator light (LED) blinked, display change to ODO, TRIP, CLOCK, STOP WATCH and FUEL.
- ★If the display function does not work, replace the meter assembly.

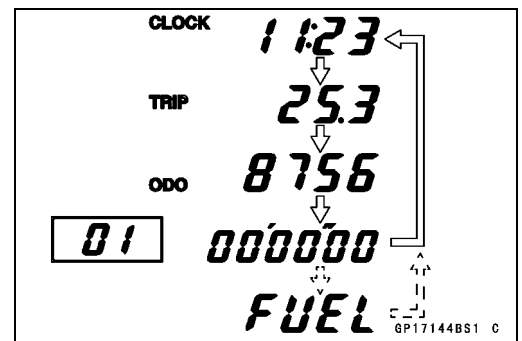
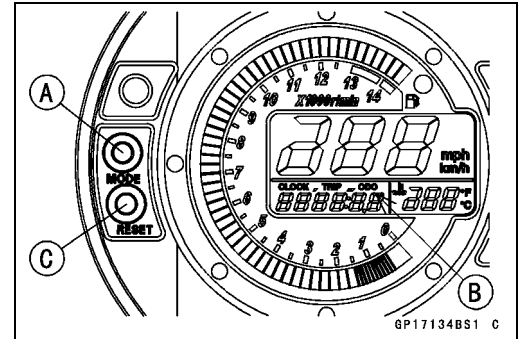

- Indicate the clock mode.
- Check that when the RESET button in CLOCK mode is pushed for more than two seconds, the meter display turns to the clock set mode.
- Both the hour and minute display start flashing.

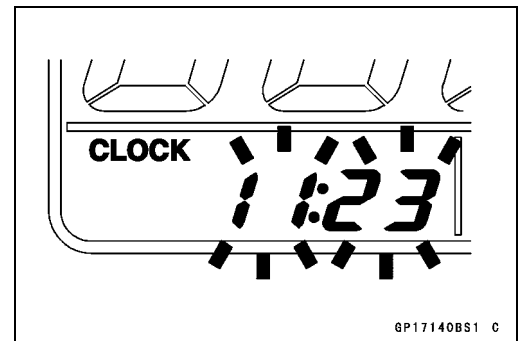

- In the HOUR/MINUTE setting mode, press the reset button [C] again to effect the HOUR setting mode.
- The hour display flashes on the display.
- Press the mode selector button [A] to set the hour.

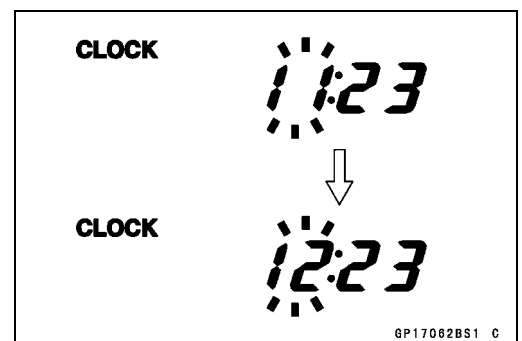

# 16-68 ELECTRICAL SYSTEM

## Meter, Gauge, Indicator Unit

- In the HOUR setting mode, press the reset button [C] to effect the MINUTE setting mode.
- The minute display flashes on the display.
- Press the mode selector button [A] to set the minute.

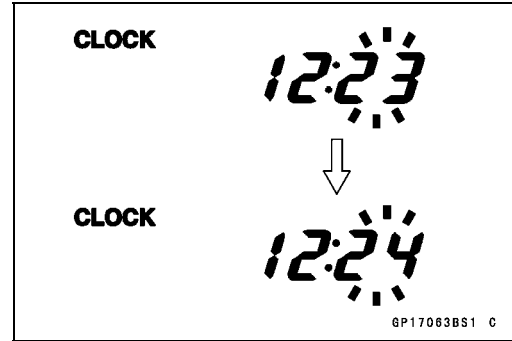

- In the MINUTE setting mode, press the reset button [C] to return to the HOUR/MINUTE setting mode.
- Press the mode selector button [A] to complete the time setting process.
- The clock starts counting the seconds as soon as the mode selector button is pressed.

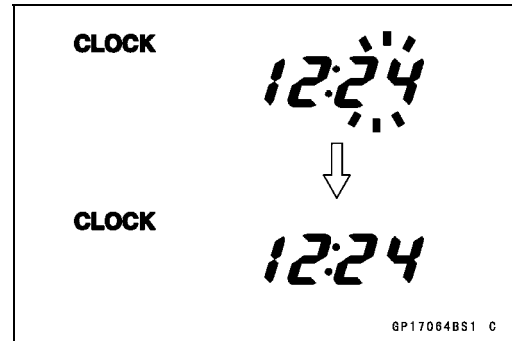

- Indicate the ODO mode.
- ★ If the display function does not work and adjust, replace the meter assembly.
- ★ Check that the display [A] [B] change to the mile and °F, Mile and °C, km and °F, km and °C display each time by pushing the RESET bottom while MODE bottom pushed in.

### NOTE

○ Mile/Km Display can alternate between English and metric modes (mile and km) in the digital meter. Make sure that km or mile according to local regulations is correctly displayed before riding.

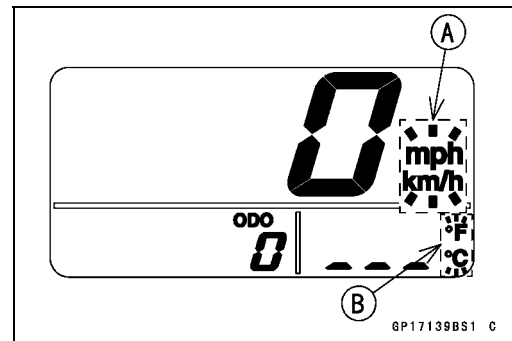

### Speedometer Check

- Connect the 12 V battery and terminals in the same manner as specified in the "Liquid Crystal Display (LCD) Segments Check".
- The speed equivalent to the input frequency is indicated in the oscillator [A], if the square wave (illustrated as shown) would be input into the terminal [16].
- Indicates approximately 60 mph in case the input frequency would be approximately 124 Hz.
- Indicates approximately 60 km/h in case the input frequency would be approximately 77 Hz.

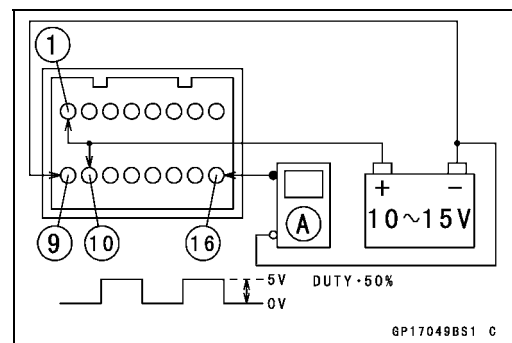

- If the oscillator is not available, the speedometer can be checked as follows.
- Install the meter unit.
- Raise the rear wheel off the ground, using the jack.
- Turn on the ignition switch.
- Rotate the rear wheel by hand.
- Check that the speedometer shows the speed.
- ★ If the speedometer does not work, check the speed sensor electric source voltage and speed sensor.
- ★ The electric source voltage and speed sensor are normal, replace the meter assembly.

## Meter, Gauge, Indicator Unit

### Speed Sensor Electric Source Check

- Connect the 12 V battery and terminals in the same manner as specified in the "Liquid Crystal Display (LCD) Segments Check".
- Set the hand tester to the DC 25 V range and connect it to the terminals [12] and [9].
- ★ If the voltage is less than 8 V, replace the meter assembly.

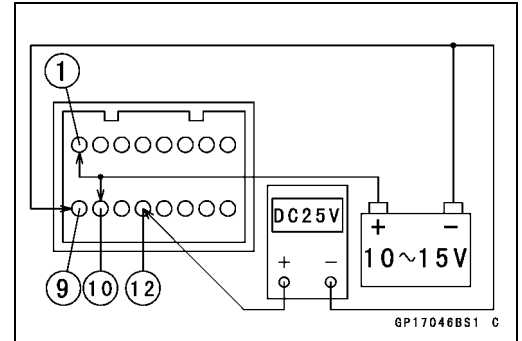

### Odometer Check

- Check the odometer with the speedometer check in the same way.
- ★ If value indicated in the odometer is not added, replace the meter assembly.

#### NOTE

- The data is maintained even if the battery is disconnected.
- When the figures come to 999999, they are stopped and locked.

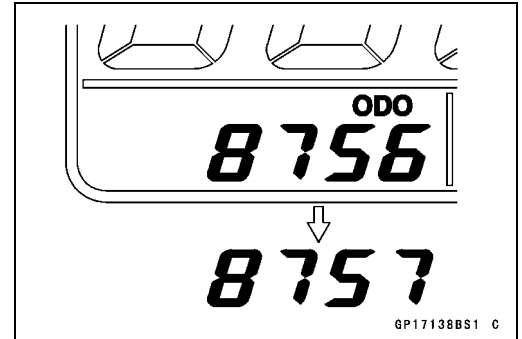

### Trip Meter Check

- Check the trip meter with the speedometer in the same way.
- ★ If value indicated in the trip meter is not added, replace the meter assembly.
- Check that when the RESET button is pushed for more than two seconds, the figure display turns to 0.0.
- ★ If the figure display does not indicate 0.0, replace the meter assembly.

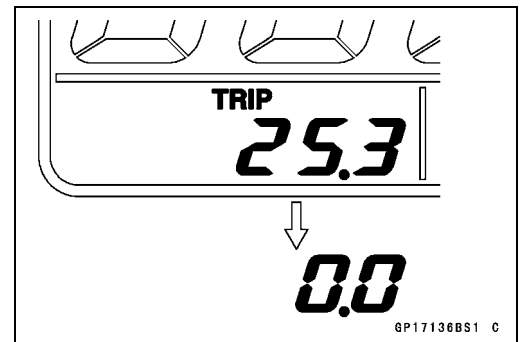

### Water Temperature Meter Check

- Connect the 12 V battery and terminals in the same manner as specified in the "Liquid Crystal Display (LCD) Segments Check".
- Connect the variable rheostat [A] to the terminal [8] as shown.
- Check that the number of segments matches the resistance value of the variable rheostat.

Resistance Value (Ω)	Temperature Meter	Warning Indicate
	-	[A] -
209.8	50°C (122°F)	[B] -
69.1	80°C (176°F)	[B] -
21.2	120°C (248°F)	[C] Flash
17	HI	[D] Flash

- If any display function does not work, replace the meter assembly.

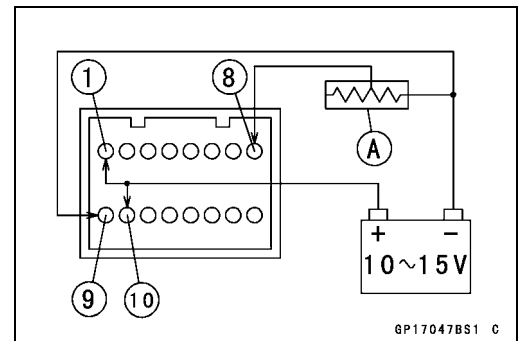

# 16-70 ELECTRICAL SYSTEM

## Meter, Gauge, Indicator Unit

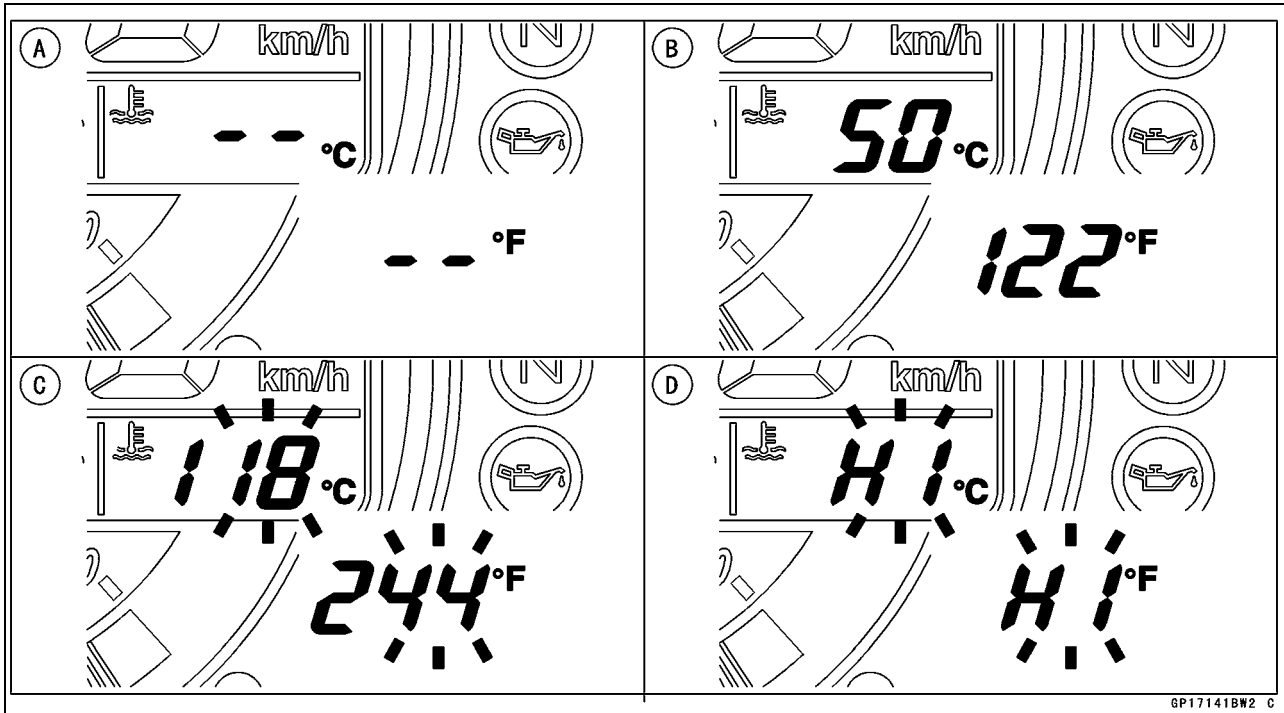

### Tachometer Check

- Connect the 12 V battery and terminals in the same manner as specified in the "Liquid Crystal Display (LCD) Segments Check".
- The revolutions per minute (rpm) equivalent to the input frequency is indicated in the oscillator [A] if the square wave (illustrated as shown) would be input into the terminal [7].
- Indicates approximately 6 000 rpm in case the input frequency would be approximately 200 Hz.
- If the oscillator is not available, the tachometer can be checked as follows.
  - Connect the 12 V battery and terminals in the same manner as specified in the "Liquid Crystal Display (LCD) Segments Check".
  - Using an auxiliary wire, quickly open and connect the terminal [1] to the terminal [7] repeatedly.
  - Then the tachometer segment [A] should flick [B].
- ★ If the hand does not flick, replace the meter assembly.

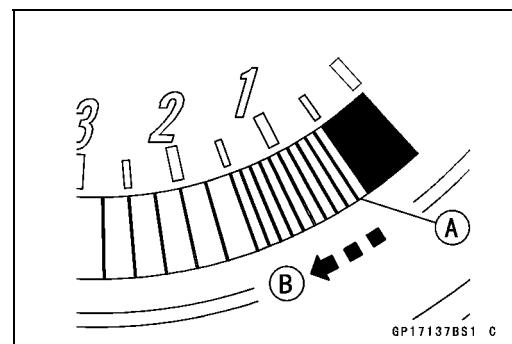
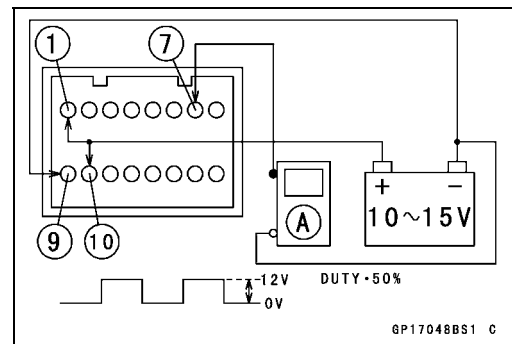



**Meter, Gauge, Indicator Unit**

**Stop Watch Check**

- Connect the 12 V battery and terminal in the same manner as specified in the “Liquid Crystal Display (LCD) Segments Check”.
- Press the mode selector button each time to set the stop watch mode.
- Connect the auxiliary wire to the terminal [3] as shown, then stop watch start to count.
- While count the stop watch, connect the auxiliary wire to the terminal [4] as shown, then indicate the counted time during ten seconds.
- Connect the variable rheostat [A] to the terminal [8] as shown.
- When Set the resistance to less than  $21.1\Omega$ , lap display segment indicate the water temperature.
- ★ If the display function does not work, replace the meter assembly.

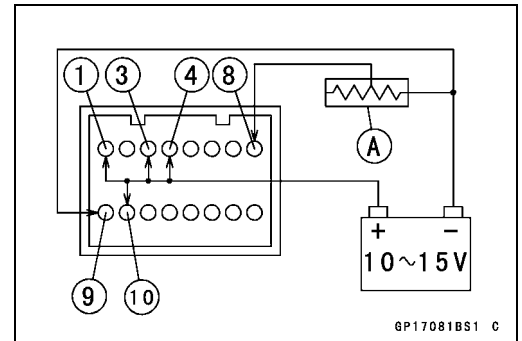
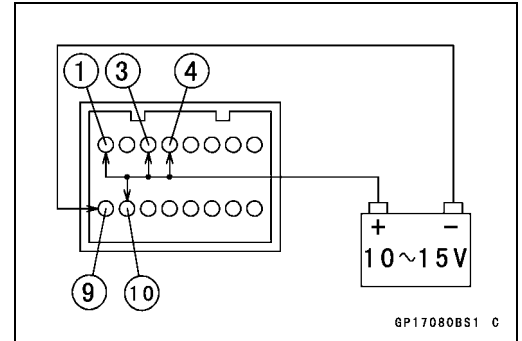

**LED Lights Inspection**

- Connect the 12 V battery and terminals in the same manner as specified in the “Liquid Crystal Display (LCD) Segments check.”
- Neutral Indicator Light (LED) [A]
- FI Indicator Light (LED) [B]
- Oil Pressure Warning Indicator Light (LED) [C]
- Turn Signal Indicator Light (LED) [D]
- High Beam Indicator Light (LED) [E]
- Fuel Level Warning Indicator Light (LED) [F]
- Shift Up Indicator Light (LED) [G]

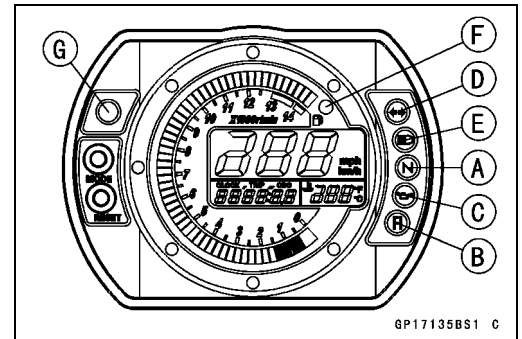

- Using the auxiliary leads and harness adapter, connect a 12 V battery to the meter unit connector as follows.

**Special Tool - Harness Adapter: 57001-1542**

**Neutral Indicator Light (LED)**

Battery Negative (-) Terminal To Terminal [5]

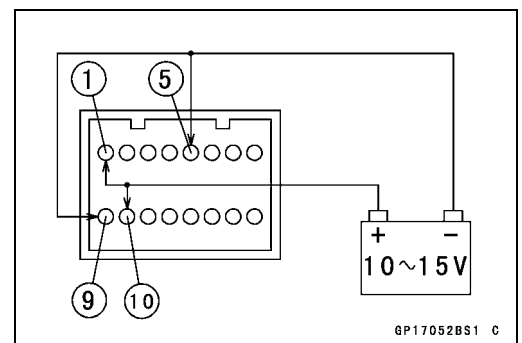

# 16-72 ELECTRICAL SYSTEM

## Meter, Gauge, Indicator Unit

### FI Indicator Light (LED)

Battery Negative (-) Terminal To Terminal [6]

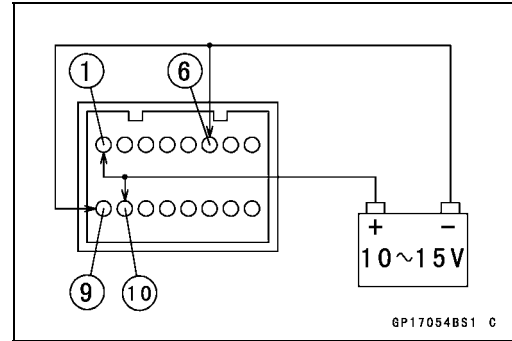

### Oil Pressure Warning Indicator Light (LED)

Battery Negative (-) Terminal To Terminal [11]

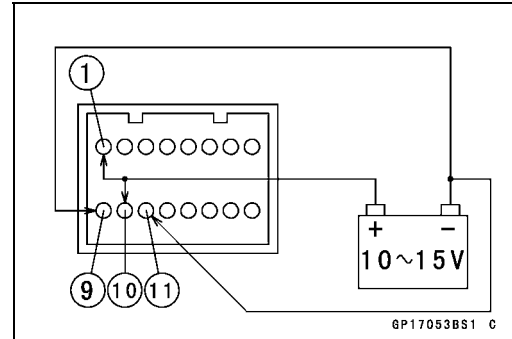

### Right and Left Turn Signal Indicator Light (LED)

Battery Positive (+) Terminal to Terminal [13]

Battery Positive (+) Terminal to Terminal [14]

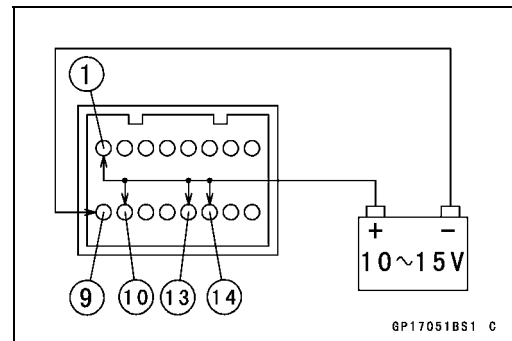

### High Beam Indicator Light (LED)

Battery Positive (+) Terminal to Terminal [15]

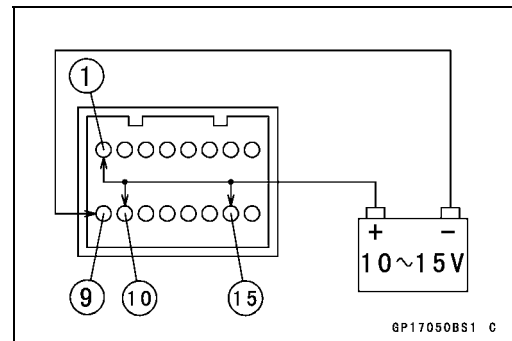

### Fuel Level Warning Indicator Light (LED)

- Connect a variable rheostat [C] to terminal [2] and [9] as shown.
- Adjust the resistance value to the approximately 22 Ω.
- The FUEL segments flashes on the display.

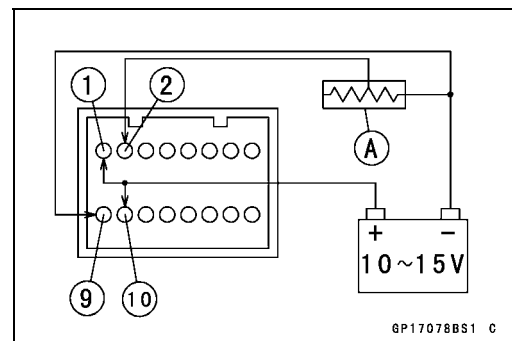

★ If each lights (LED) does not go on, replace the meter assembly.

**Meter, Gauge, Indicator Unit**

**Shift Up Indicator Light (LED)**

- Connect the 12 V battery and terminal in the same manner as specified in the “Liquid Crystal Display (LCD) Segments Check”.
- The revolutions per minute (rpm) equivalent to the input frequency is indicated in the oscillator [A] if the square wave (illustrated as shown) would be input into the terminal [7].
- When set the oscillator more than 440 Hz, shift up indicator light (LED) go on.

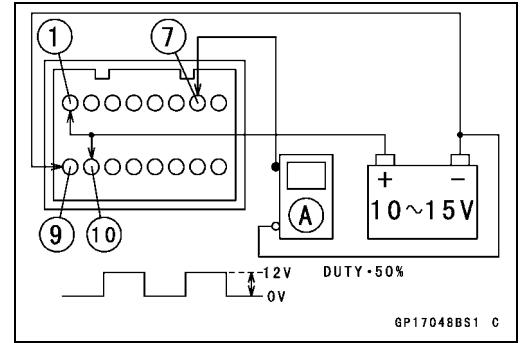

★ If each LED lights does not go on, replace the meter assembly.

**Meter Circuit**

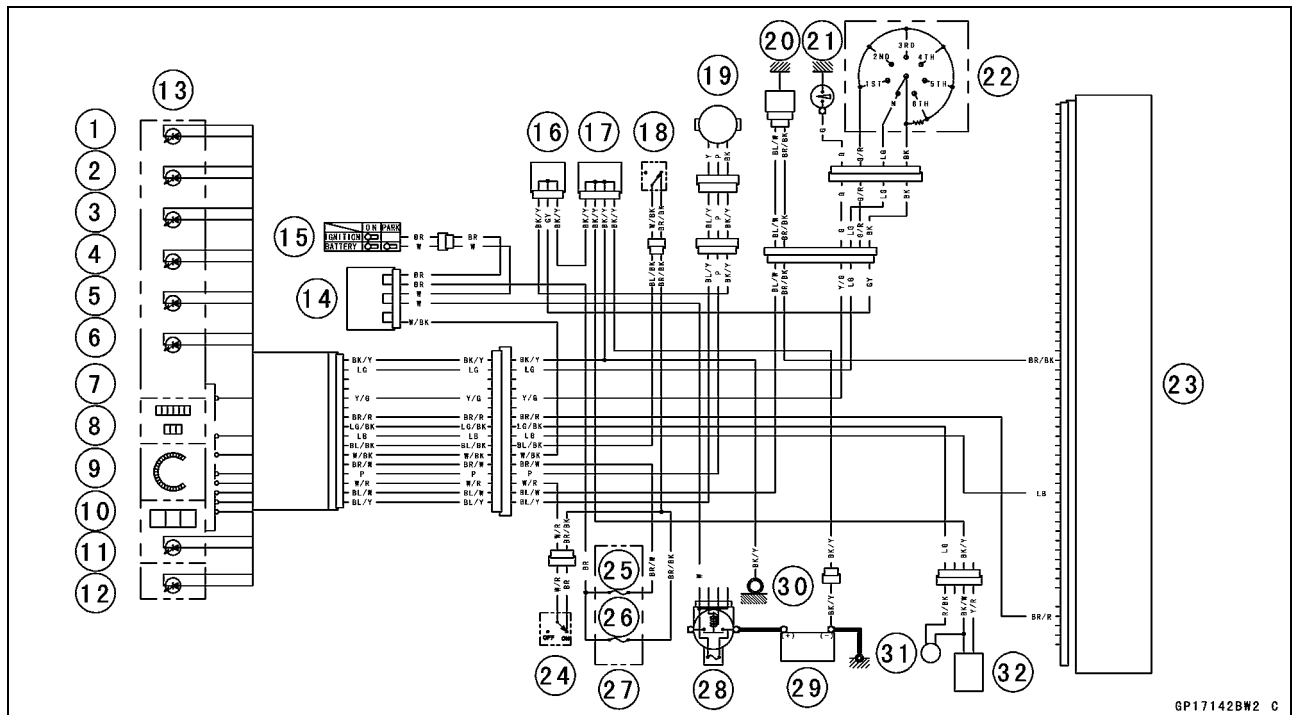

- |   |                              |
|---|------------------------------|
| 1. Turn Signal Indicator Light (LED)              | 17. Joint Connector 2        |
| 2. High Beam Indicator Light (LED)                | 18. Stop Watch Switch        |
| 3. Neutral Indicator Light (LED)                  | 19. Speed Sensor             |
| 4. Oil Pressure Warning Indicator Light (LED)     | 20. Water Temperature Sensor |
| 5. Fuel Level Warning Indicator Light (LED)       | 21. Oil Pressure Switch      |
| 6. FI Indicator Light (LED)                       | 22. Gear Position Switch     |
| 7. Odometer/Trip Meter/Clock/Stop Watch Indicator | 23. Electric Control Unit    |
| 8. Water Temperature Gauge                        | 24. Lap Switch               |
| 9. Tachometer                                     | 25. Ignition Fuse 10 A       |
| 10. Speedometer                                   | 26. Horn Fuse 10 A           |
| 11. Meter Light (LED)                             | 27. Fuse Box                 |
| 12. Shift Up Indicator Light (LED)                | 28. Main Fuse 30 A           |
| 13. Meter Assembly                                | 29. Battery 12 V 10 Ah       |
| 14. Joint Connector 4                             | 30. Frame Ground             |
| 15. Ignition Switch                               | 31. Fuel Reserve Switch      |
| 16. Joint Connector 1                             | 32. Fuel Pump                |

## 16-74 ELECTRICAL SYSTEM

### Immobilizer System (Equipped Models)

This motorcycle is equipped with an immobilizer system to protect the motorcycle from theft. This system provides a theft proof device by means of matching a code between the inbuilt key transponder and ECU (Electronic Control Unit). If the code does not match, ignition system, injectors, sub-throttle valve actuator and exhaust butterfly valve actuator will not operate and the engine will not start.

#### Abstract

- Do not keep more than one immobilizer key of any system on a key ring. Jamming of the key code signal may occur and the operation of the system may be affected.
- The FI indicator light illuminates for two seconds and then extinguishes when the ignition is first switched on. This shows the system is operating correctly.
- If the FI indicator light illuminates when the ignition switch is turned to the ON position and stays illuminated this shows a fault in the DFI system.
- If the FI indicator light flashes when the ignition switch is turned to the ON position this shows the immobilizer system has a fault. Refer to service code to identify the faulty component.
- The FI indicator light will flash for a period of 24 hours once the ignition switch has been switched off and the key removed. This flashing can be set to on or off as desired by holding the Mode and Reset buttons down for two seconds within twenty seconds of switching the ignition off.
- If all coded keys (master key and user keys) are lost the ECU and ignition switch will have to be replaced.
- The immobilizer system can not function until the master key code is registered in the ECU.
- A total of six keys can be registered in the ECU at any one time (one master key and five user keys).
- If the master key is lost it is not possible to register new user keys.

#### Operational Cautions

1. Do not put two keys of any immobilizer system on the same key ring.
2. Do not submerge any key in water.
3. Do not expose any key to excessively high temperature.
4. Do not place any key close to magnet.
5. Do not place a heavy item on any key.
6. Do not grind any key or alter its shape.
7. Do not disassemble the plastic part of any key.
8. Do not drop the key and/or apply any shocks to the key.
9. When a user key is lost, the user should go to his dealer to invalidate the lost key registration in the electronic control unit (ECU).
10. When the master key is lost, the user should go to his dealer and have a new ECU installed and register a new master key and user keys.

#### NOTE

○ No.9 and 10 are strongly recommended to the customer to ensure security of the motorcycle.

#### Key Registration

##### Case 1: When the user key has been lost or additional spare user key is required.

- Prepare a new spare user key.
- Cut the key in accordance with the shape of the current user key.
- Remove:
  - Seats (see Frame chapter)
- Disconnect the immobilizer/Kawasaki self-diagnosis system connector [A].



## Immobilizer System (Equipped Models)

- Connect the key registration unit [A].  
Special Tool - Key Registration Unit: 57001-1582



- Insert the master key to the ignition switch and turn it ON.  
**Verified**

- The FI indicator light [A] blinks to display the registration mode (go to the next step).

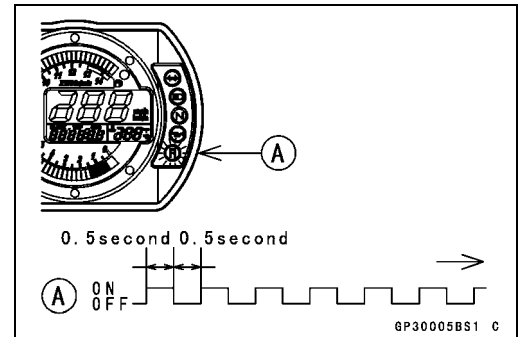

### Not Verified

- The FI indicator light [A] blinks to display the collation error (refer to the following failure illustrations).  
Immobilizer Amplifier Failure

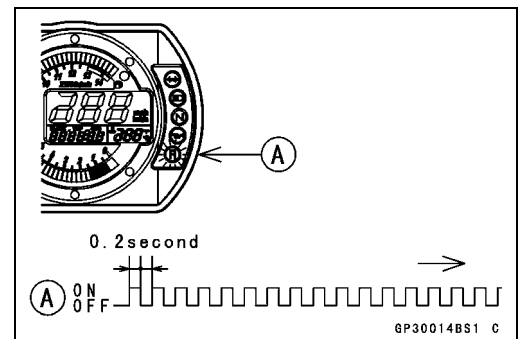

### Master Key Collation Error

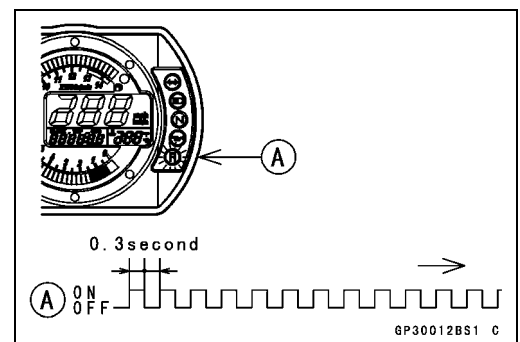

- Turn the master key OFF and remove the master key.  
○The FI indicator light [A] blinks continuously to display that the ECU is in the registration mode for 15 seconds.

### NOTE

- Insert next key and turn ON within 15 seconds after previous key is turned off and removed otherwise registration mode will be ended and the FI indicator light stops flashing.
- To return to the registration mode start the master key verification procedure. This applies to all user key registration.

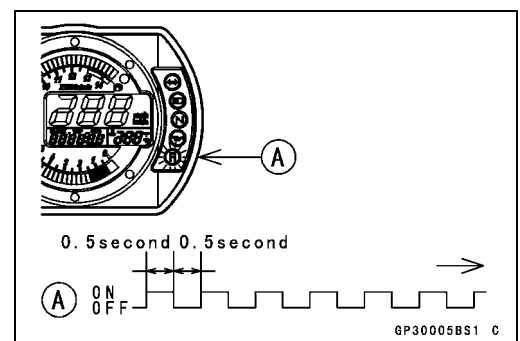

# 16-76 ELECTRICAL SYSTEM

## Immobilizer System (Equipped Models)

- Insert the user key 1 to the ignition switch and turn it ON.

### NOTE

○Keep the other user key away from the immobilizer antenna.

- If there is any problem in the registration, the FI indicator light [A] blinks to display the collation error.  
Immobilizer Amplifier Failure

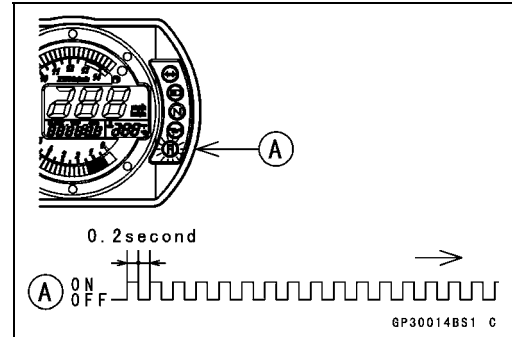

When Registered User Key is Inserted.

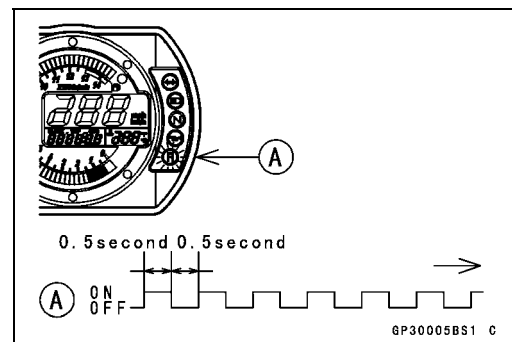

User Key Collation Error

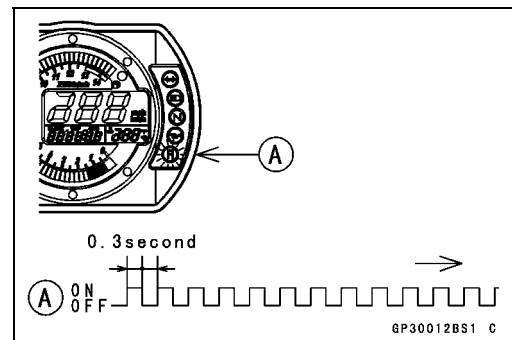

- The user key 1 is successfully registered in the ECU.
- The FI indicator light [A] blinks 2 times and stops for 1 second and then repeats this cycle.

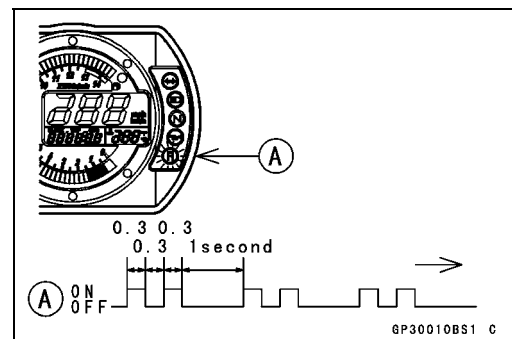

**Immobilizer System (Equipped Models)**

- Turn the user key 1 OFF and remove off the user key 1.
- The FI indicator light [A] blinks to display the registration mode.

**NOTE**

- Turn off the ignition switch and wait for the period of 15 seconds or more. The registration mode automatically finishes and the FI indicator light will switch off.
  - This procedure registered the master key and one user key.
  - Continue with the procedure to register the second and later keys before the 15 seconds period has elapsed.
- Insert the user key 2 to the ignition switch and turn it ON.

- If there is any problem in the registration, the FI indicator light [A] blinks to display the collation error.  
Immobilizer Amplifier Failure

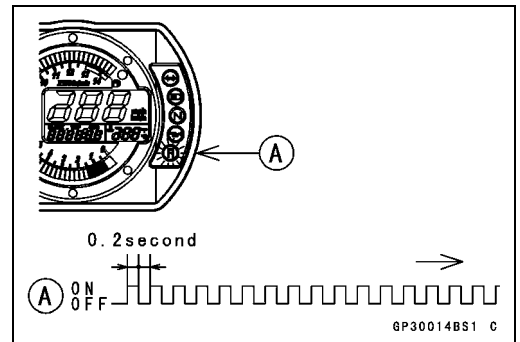
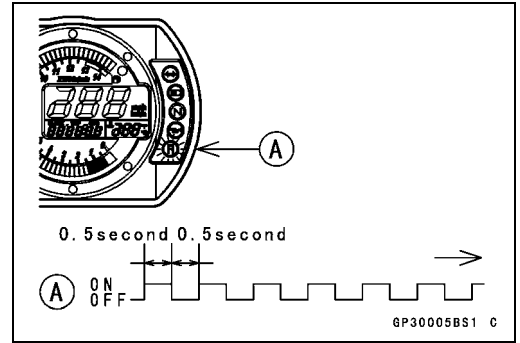

When Registered User Key is Inserted.

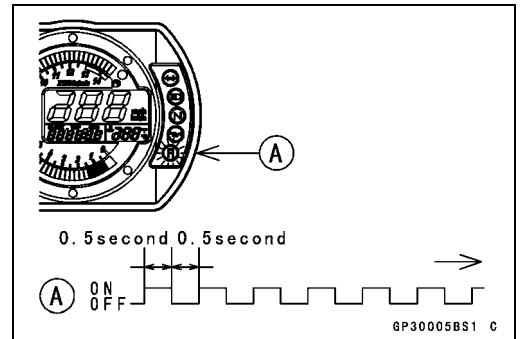

User Key Collation Error

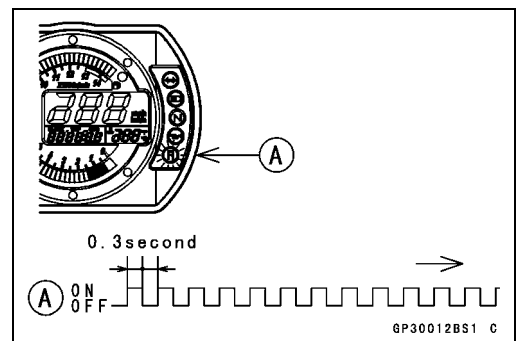

# 16-78 ELECTRICAL SYSTEM

## Immobilizer System (Equipped Models)

- The user key 2 is registered in the ECU.
- The FI indicator light [A] blinks 3 times and stops for 1 second and then repeats this cycle.
- This procedure has registered the master key and 2 user keys.
- Continue with the procedure to register an additional 3 user keys.

**NOTE**

○ The ECU can store up the six key codes (master key × 1 and user key × 5).

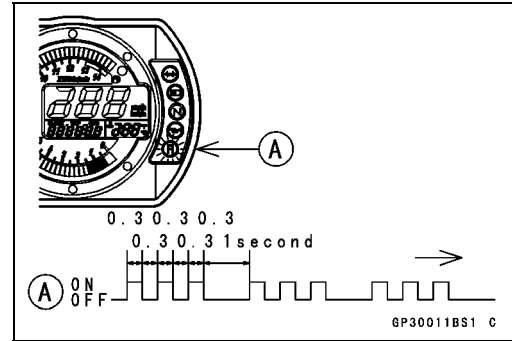

### User Key Indicator Flashes

	FI Indicator Light Blinks	FI Indicator Light Stop	Remarks
User Key 3	4 times	1 seconds	Repeat
User Key 4	5 times	1 seconds	Repeat
User Key 5	6 times	1 seconds	Repeat

- Turn OFF the ignition switch and wait for period of more than 15 seconds.
- The registration mode automatically ends.
- FI indicator light goes off [A].

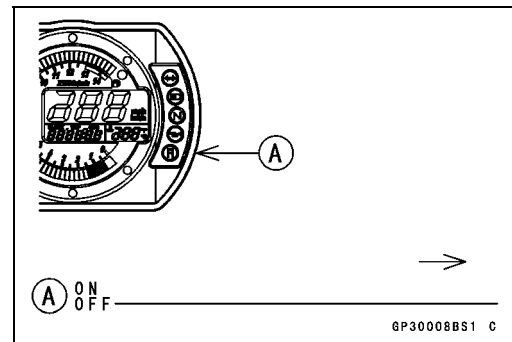

- Remove the key registration unit and connect the immobilizer Kawasaki self-diagnostic system connector.

**NOTE**

○ Turn the ignition switch ON with the registered user key.  
 ○ Check that the engine can be started using all registered user keys.



Immobilizer System (Equipped Models)

Spare User Key Registration Flow Chart

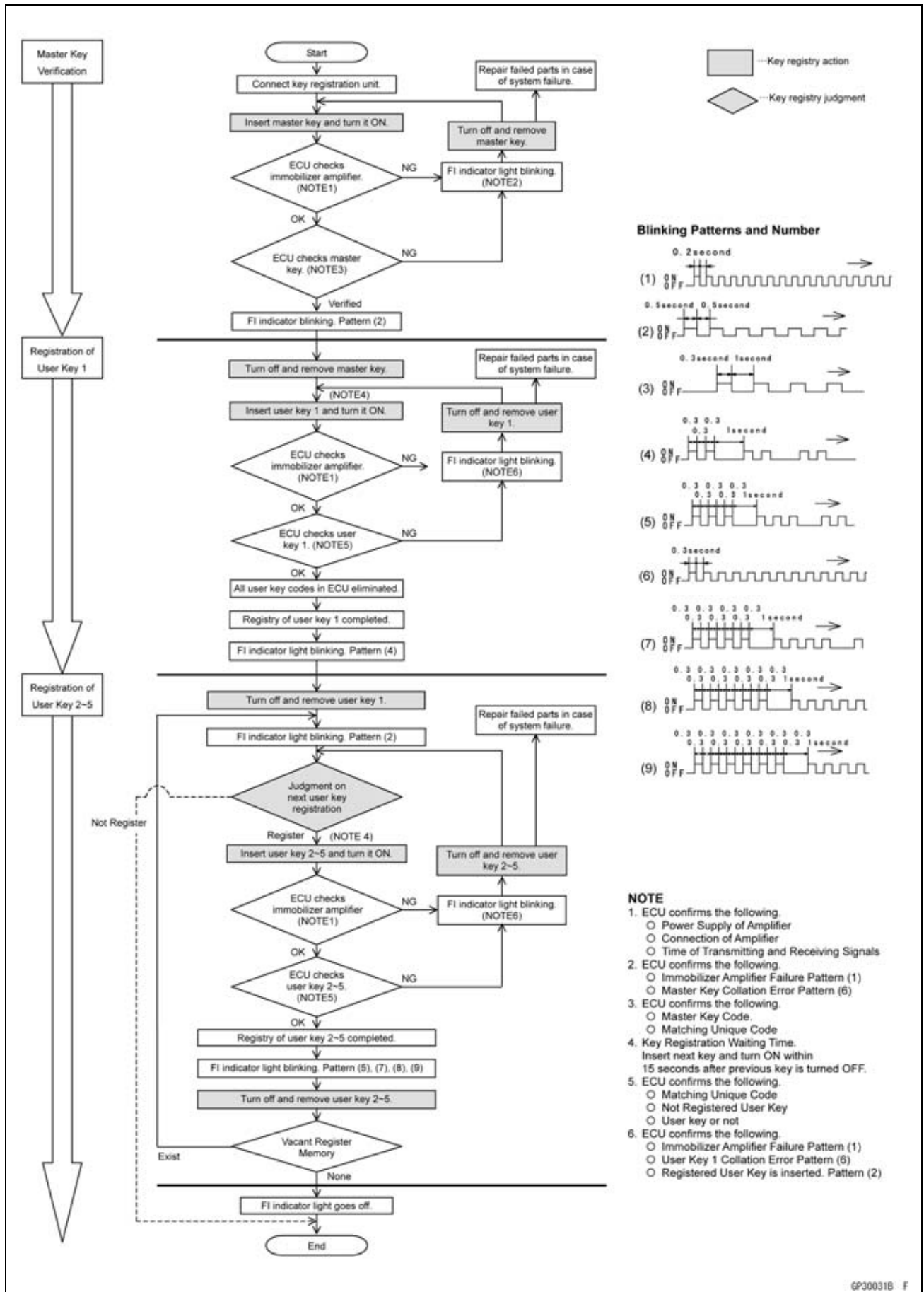

# 16-80 ELECTRICAL SYSTEM

## Immobilizer System (Equipped Models)

**Case 2: When the ignition switch is faulty and to be replaced.**

- Prepare a new ignition switch [A] and two new user keys [B].
- These parts are available as a set. Prepare the current master key [C].

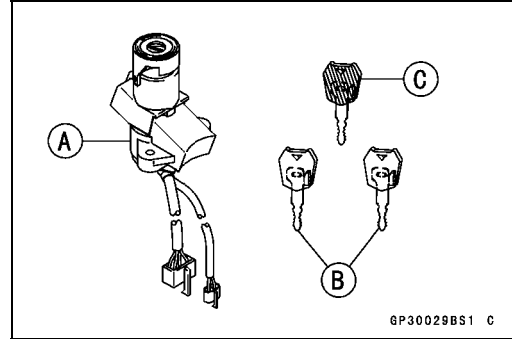

- Remove:
    - Ignition Switch and Immobilizer Antenna (see Immobilizer System Parts Replacement)
    - Seats (see Frame chapter)
  - Disconnect the immobilizer/Kawasaki self-diagnostic system connector.
  - Connect the key registration unit [A].
- Special Tool - Key Registration Unit: 57001-1582**



- Connect:
  - New Ignition Switch Lead Connector [A]
  - Immobilizer Antenna Lead Connector [B]

### NOTE

○ Keep the antenna more than 15 cm from the ignition switch.

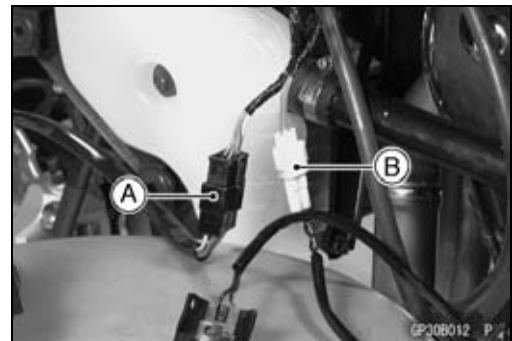

- Put the current master key [A] at the antenna [B]. Insert the new user key 1 [C] to the new ignition switch [D] and turn it ON.

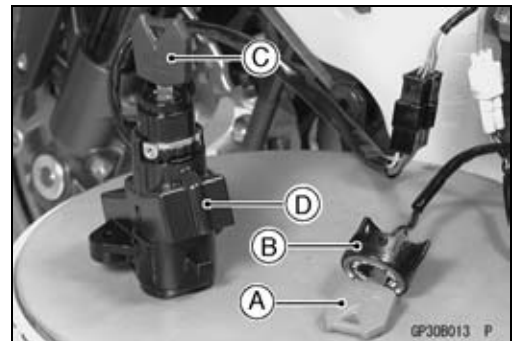

### Verified

- The FI indicator light [A] blinks to display the ECU is in the registration mode (go to the next step).

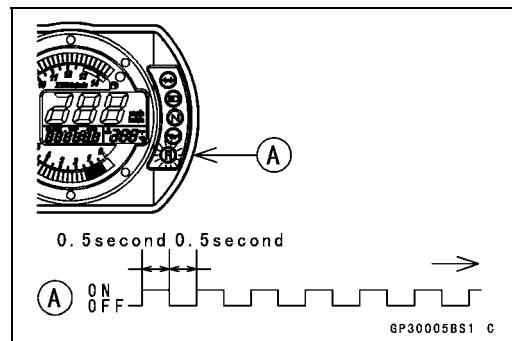

## Immobilizer System (Equipped Models)

### Not Verified

- The FI indicator light [A] blinks to display the collation error.

Immobilizer Amplifier Failure

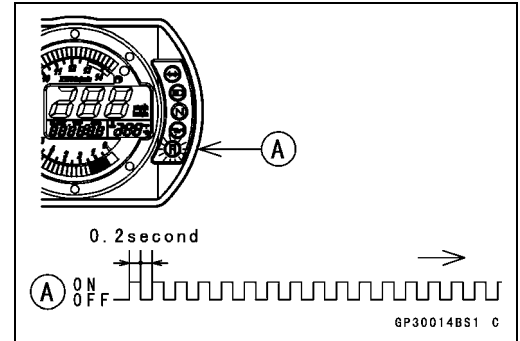

Master Key Collation Error

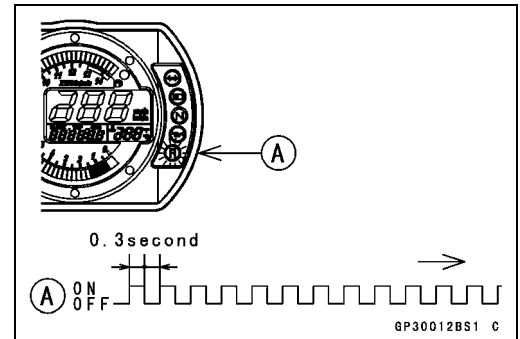

- Turn off and remove the new user key 1.
- Temporarily place the antenna [A] on the new ignition switch [B].
- Insert the user key 1 [C] again into the new ignition switch and turn it ON.

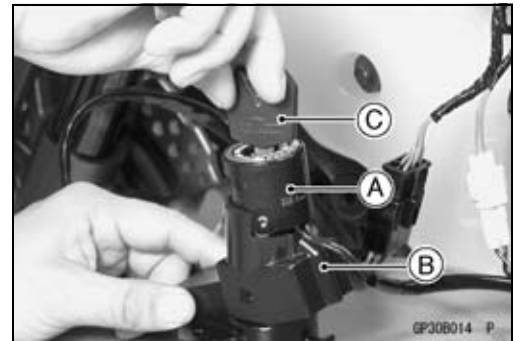

### NOTE

- Place the antenna on the ignition switch, insert the next key and turn ON within 15 seconds after previous key is turned off and removed otherwise registration mode will be ended and the FI indicator light stops flashing.
  - To return to the registration mode start the master key verification procedure. This applies to all user key registration.
  - Keep other user keys away from the immobilizer antenna.
- If there is any problem in the registration, the FI indicator light [A] blinks to display the collation error.
- Immobilizer Amplifier Failure

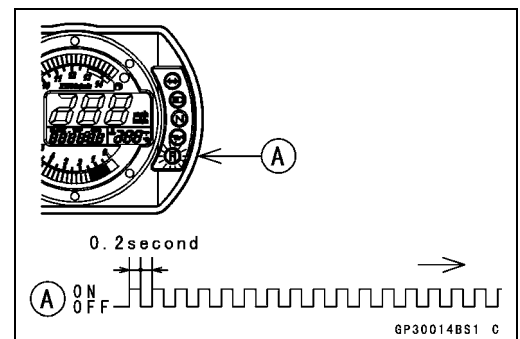

# 16-82 ELECTRICAL SYSTEM

## Immobilizer System (Equipped Models)

When Registered User Key is Inserted.

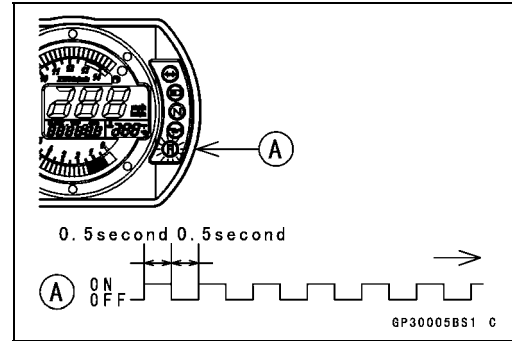

User Key Collation Error

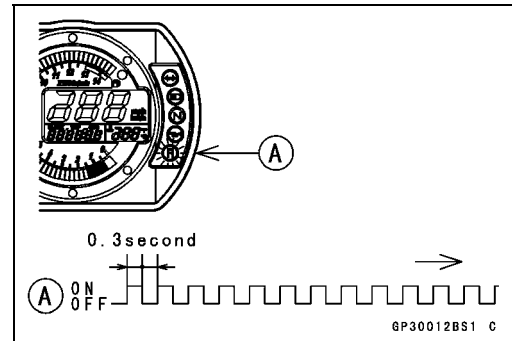

- The user key 1 is successfully registered in the ECU.
- The FI indicator light [A] blinks 2 times and stops for 1 second and then repeats this cycle to indicate successful registering of user key 1.

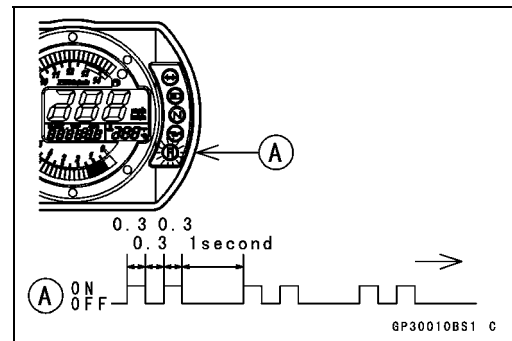

- Turn off and remove user key 1.
- The FI indicator light [A] blinks to display the registration mode.

### NOTE

- Turn off the ignition switch and wait for the period more than 15 seconds. The registration mode automatically ends and FI indicator light goes off.
  - This procedure has , registered the master key and one user key.
  - Continue the procedure to program the second and later keys.
- Insert the user key 2 to the ignition switch and turn it ON.

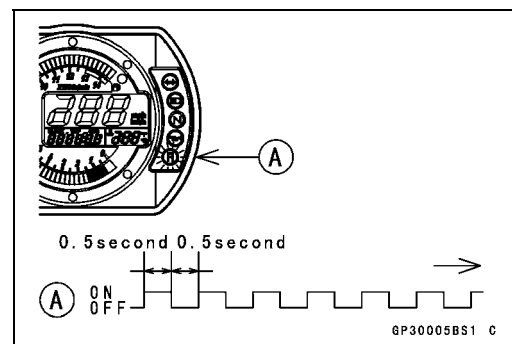

**Immobilizer System (Equipped Models)**

○If there is any problem in the registration, the FI indicator light [A] blinks to display the collation error.  
Immobilizer Amplifier Failure

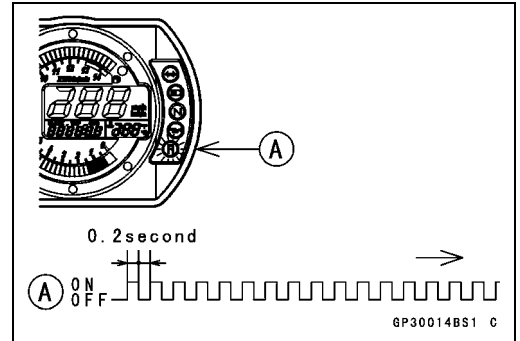

When Registered User Key is Inserted.

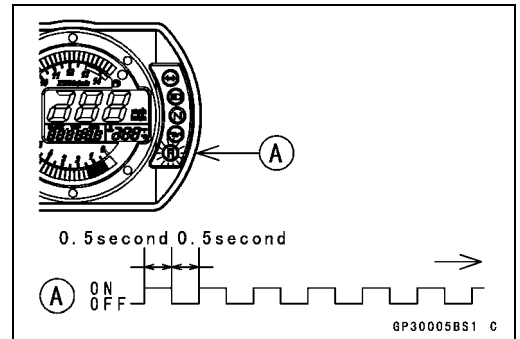

User Key Collation Error

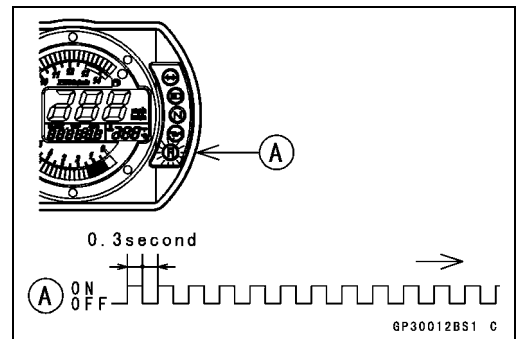

- The user key 2 is successfully registered in the ECU.
- The FI indicator light [A] blinks 3 times and stops for 1 second and then repeat this cycle to indicate successful programming of user key 2.
- Turn OFF the ignition switch and wait for period more than 15 seconds.
- The registration mode automatically ends.

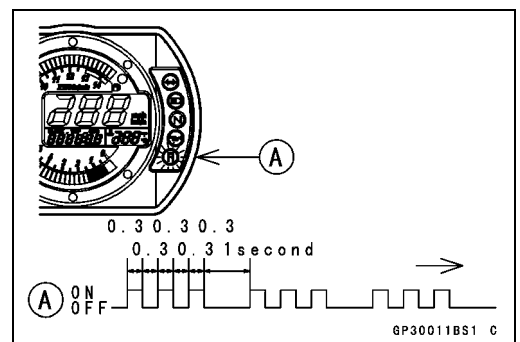

- FI indicator light goes off [A].

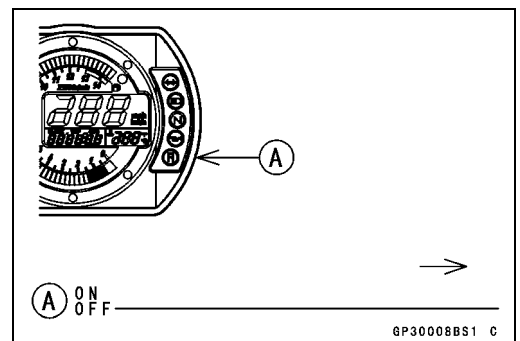

# 16-84 ELECTRICAL SYSTEM

## Immobilizer System (Equipped Models)

- Remove the key registration unit and connect the immobilizer/Kawasaki self-diagnostic system connector.

### NOTE

- Turn the ignition switch ON with the registered user key.
- Check that the engine can be started using all registered user keys.

- Install the new ignition switch and antenna.

### Case 3: When the electric control unit (ECU) is faulty and has to be replaced.

- Prepare a new ECU [A], current master key [B] and current user keys [C].

### NOTE

- The key registration unit is not required.

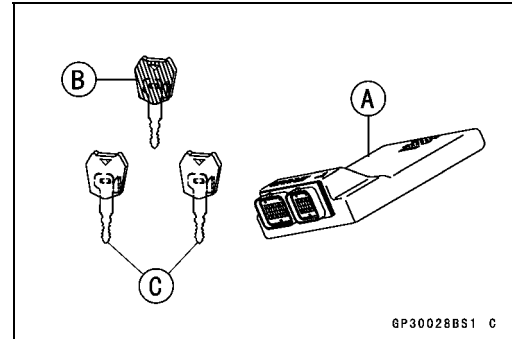

- Replace:  
Electric Control Unit (see Immobilizer System Parts Replacement)



- Insert the current master key into the ignition switch and turn it ON.

- If there is any problem in the registration, the FI indicator light [A] blinks to display the collation error.  
Immobilizer Amplifier Failure

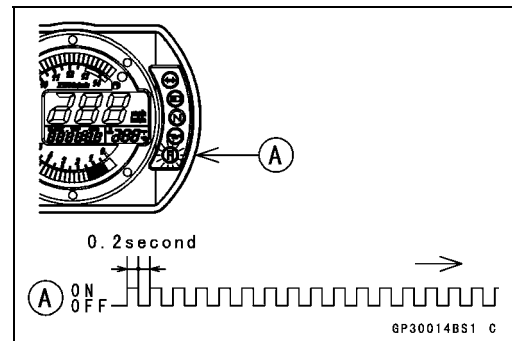

### Master Key Collation Error

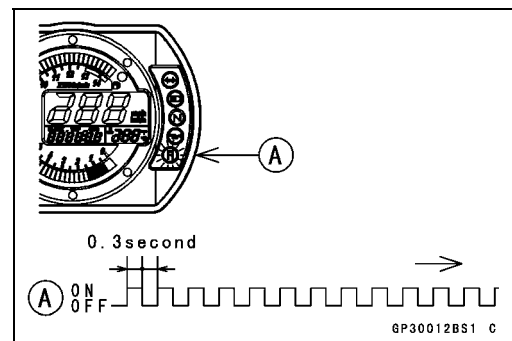

## Immobilizer System (Equipped Models)

- The master key is registered in the ECU.
- The FI indicator light [A] blinks 1 time and stops for 1 second and the repeats this cycle to indicate successful registration of the master key.

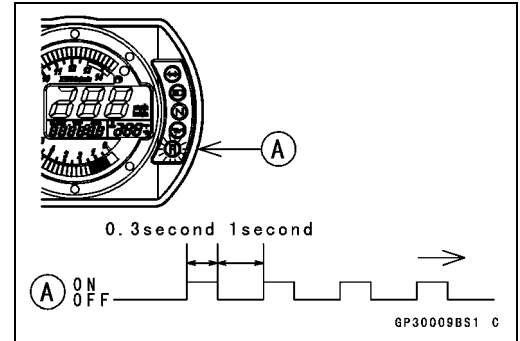

- Turn of the master key and remove it.
- The FI indicator light [A] blinks to display the registration mode.

### NOTE

- Insert next key and turn ON within 15 seconds after previous key is turned off and removed otherwise registration mode will be ended and the FI indicator light goes off.
- To return to the registration mode start the master key verification procedure. This applies to all user key registration.

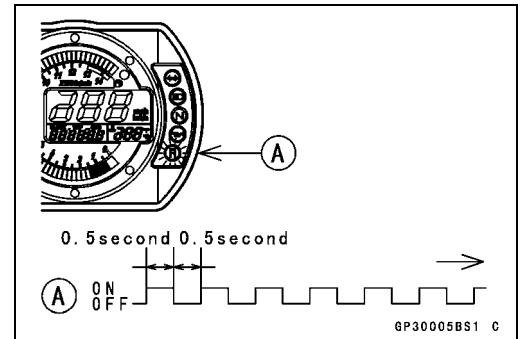

- Insert the user key 1 to the ignition switch and turn it ON.

### NOTE

- Keep the other user keys away from the immobilizer antenna.
- If there is any problem in the registration, the FI indicator light [A] blinks to display the collation error. Immobilizer Amplifier Failure

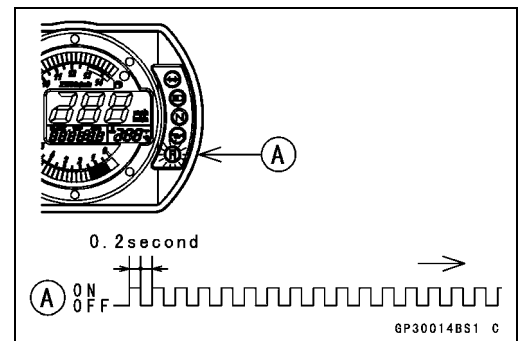

When Registered User Key is Inserted.

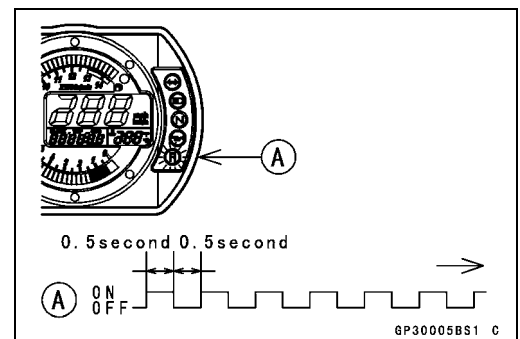

# 16-86 ELECTRICAL SYSTEM

## Immobilizer System (Equipped Models)

### User Key Collation Error

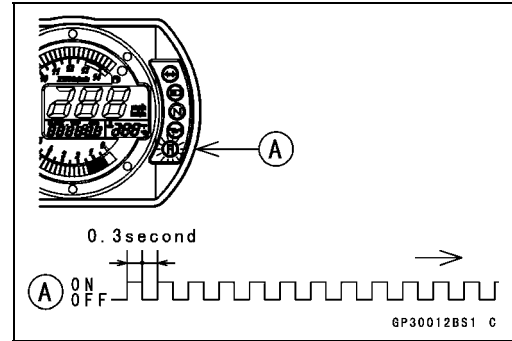

- The user key 1 is registered in the ECU.
- The FI indicator light [A] blinks 2 times and stops for 1 second and then repeats this cycle to indicate successful registration of user key.

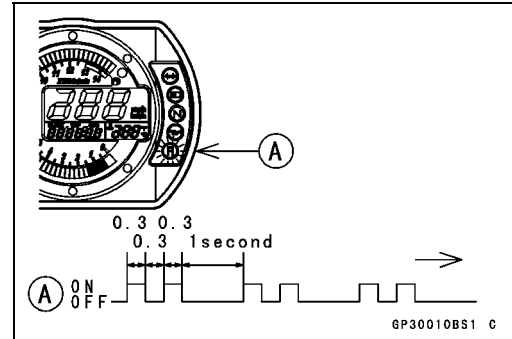

- Turn off and remove the user key 1.
- The FI indicator light [A] blinks to display the registration mode codes.

### NOTE

- Insert next key and turn ON within 15 seconds after previous key is turned off and removed otherwise registration mode will be ended and the FI indicator light goes off.
  - To return to the registration mode start the master key verification procedure. This applies to all user key registration.
- Insert the user key 2 to the ignition switch and turn it ON.
  - If there is any problem in the registration, the FI indicator light [A] blinks to display the collation error code.  
Immobilizer Amplifier Failure

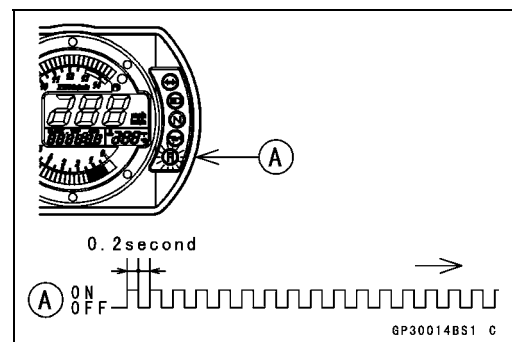
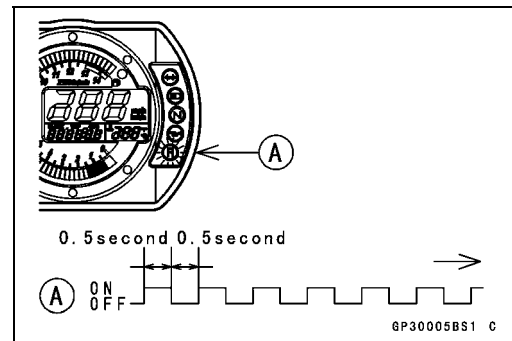



## Immobilizer System (Equipped Models)

When Registered User Key is Inserted.

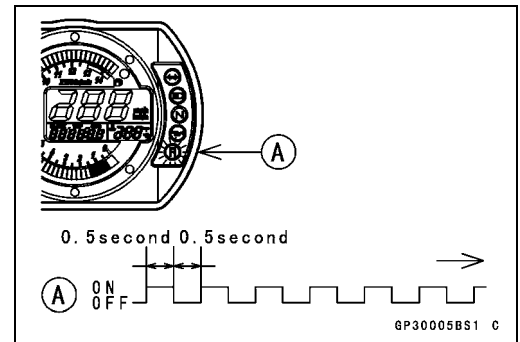

User Key Collation Error

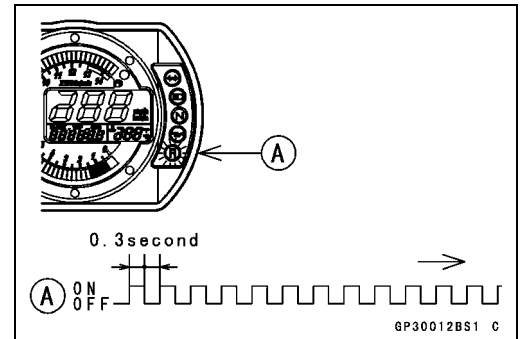

- The user key 2 is registered in the ECU.
- The FI indicator light [A] blinks 3 times and stops for 1 second and then repeats this cycle to indicate successful registration of user key 2.
- Turn OFF the ignition switch and wait for period more than 15 seconds.
- The registration mode automatically ends.

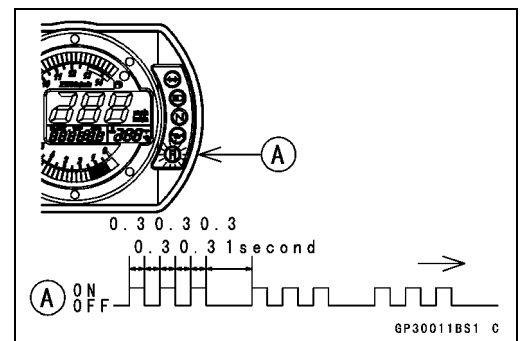

- FI indicator light goes off [A].

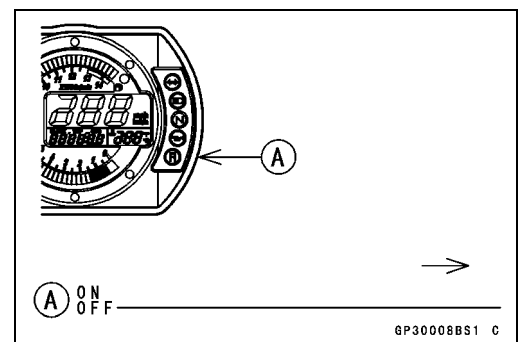

### NOTE

- Turn the ignition switch ON with the registered user key.
- Check that the engine can be started using all registered user keys.

### Case 4: When master key is faulty or lost.

The master key replacement is considered very rare case. However if it is required, the following is necessary.

### NOTE

- The ECU must be replaced with a new one because the master key code that is registered in the current ECU can not be rewritten.

## 16-88 ELECTRICAL SYSTEM

### Immobilizer System (Equipped Models)

- Prepare a new ECU [A], new master key [B] and current user keys [C].

#### NOTE

- *The key registration unit is not required.*
- *The key registration process is same as the electric control unit replacement.*

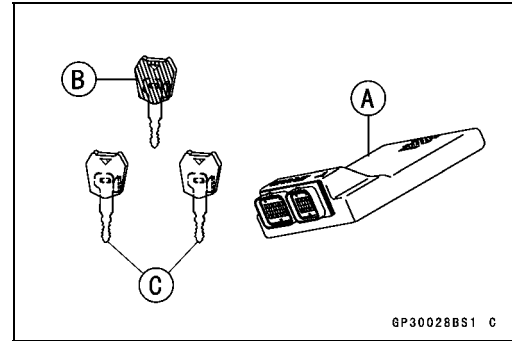

#### Case 5: When replacing the antenna.

- Prepare a new antenna.
- Refer to the Immobilizer System Parts Replacement.

#### NOTE

- *No key registration is required.*

Immobilizer System (Equipped Models)

All Keys Initial Registration Flow Chart

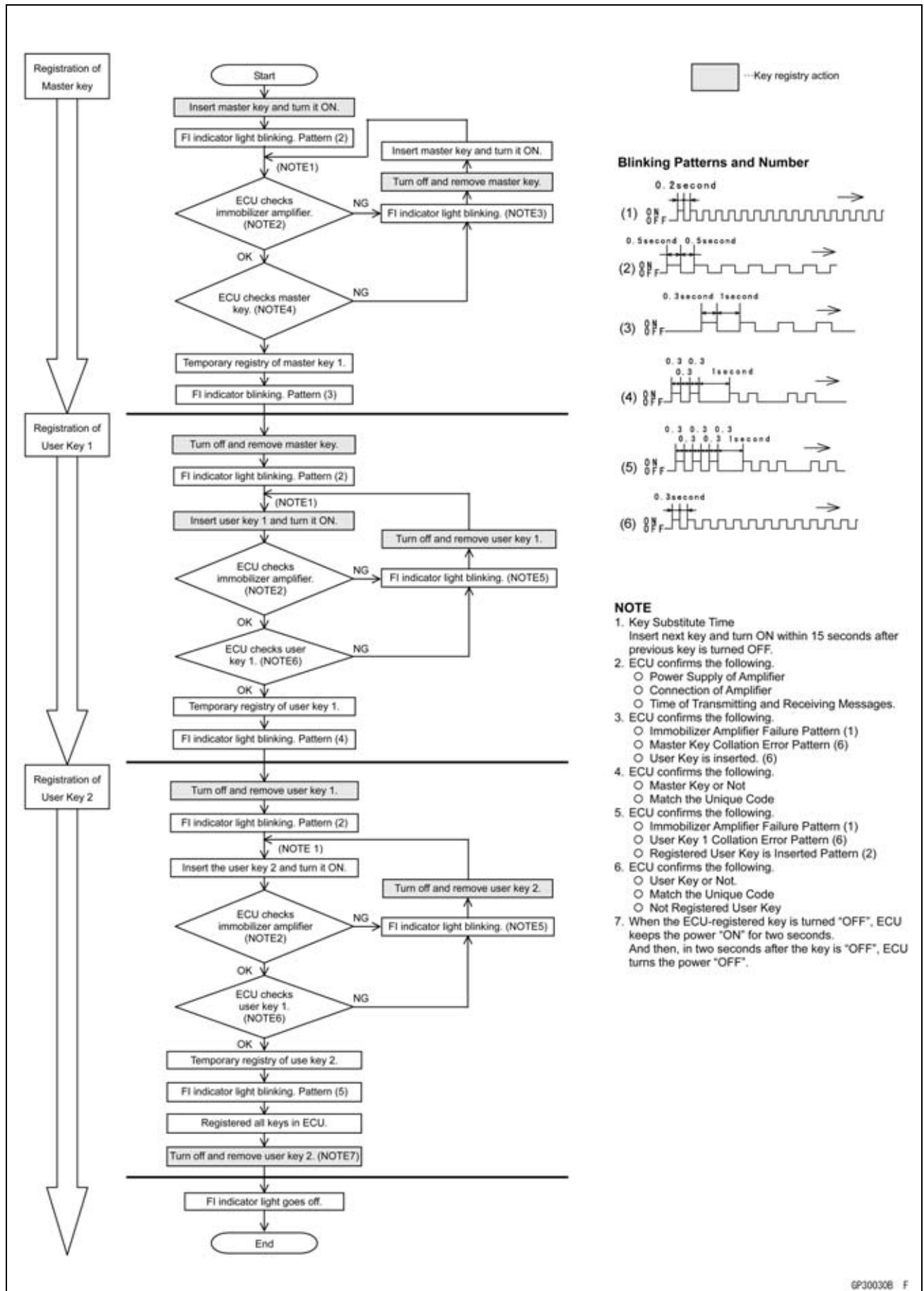

## 16-90 ELECTRICAL SYSTEM

### Immobilizer System (Equipped Models)

#### Immobilizer System Parts Replacement

##### Immobilizer Antenna

- Remove:
  - Left Lower Fairing (see Frame chapter)
  - Left Middle Fairing (see Frame chapter)
- Open the clamp (see Immobilizer Amplifier Replacement).
- Disconnect the lead connectors [A].

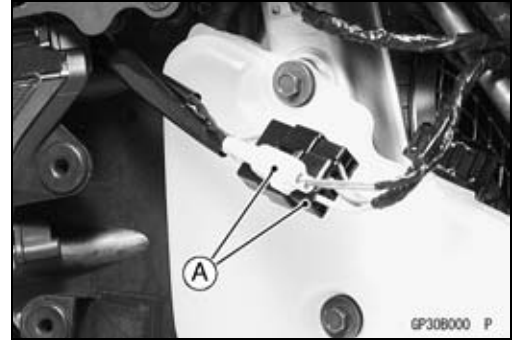

- Remove:
  - Steering Stem Head (see Steering chapter)
  - Handlebar (see Steering chapter)
- Using a small chisel [A] or punch, turn out the Torx bolts.

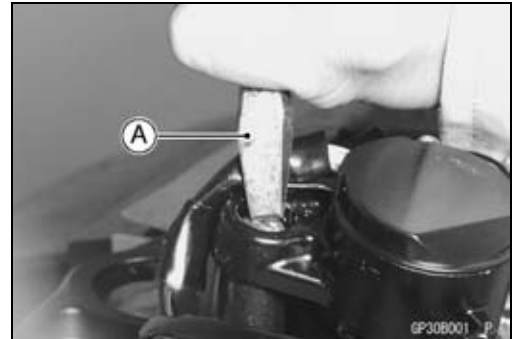

- Cut the band [A].
- Remove the screw [B].
- Remove the antenna [C] with the cover [D].
- Pull the lower parts [E] of the cover outside to clear the projection [F] of the ignition switch.

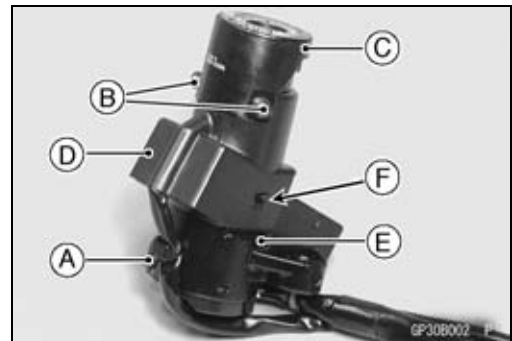

- Tighten a new Torx bolt [A] until the bolt head [B] is broken [C].
- Run the leads correctly (see Appendix chapter).

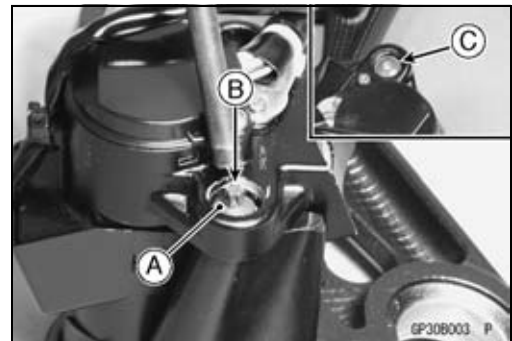

##### Immobilizer Amplifier Replacement

- Remove:
  - Left Lower Fairing (see Frame chapter)
  - Left Middle Fairing (see Frame chapter)
  - Left Inner Fairing (see Frame chapter)
- Open the clamp [A].
- Remove the screws [B].

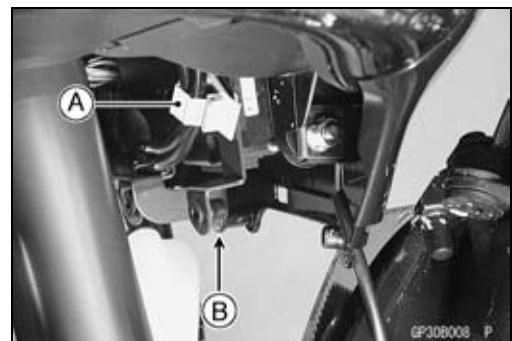

## Immobilizer System (Equipped Models)

- Disconnect the connector [A].
- Remove the amplifier [B] from the bracket [C].

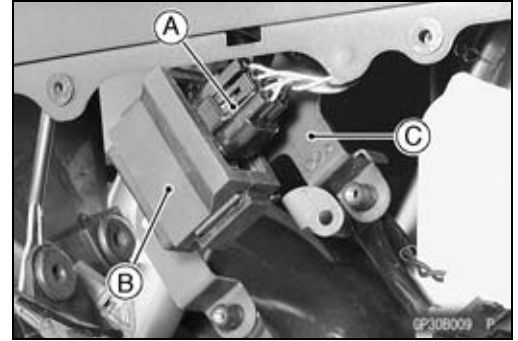

## ECU (Electric Control Unit) Replacement (for European Model)

- Remove:
  - Seats (see Frame chapter)
  - Relay Box Connectors [A]
- Using a small chisel [B] or other suitable tool, cut off the screws [C].
- Remove the upper guard bracket [D].

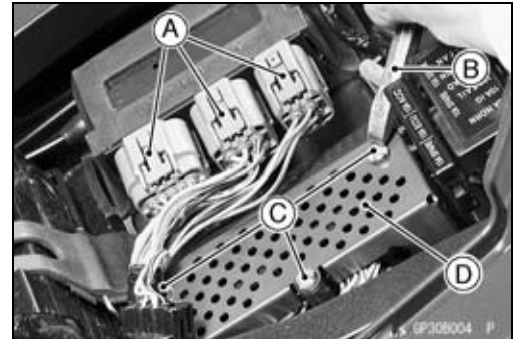

- Remove:
  - ECU with Relay Box [A]
- Disconnect the connectors [B] and remove the under guard bracket [C].

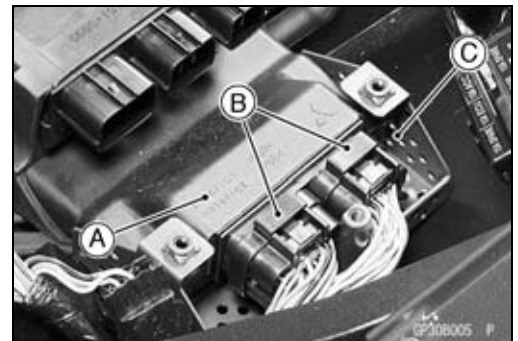

- Set the connectors [A] to the under guard bracket [B].
- Install the under guard bracket to the ECU.
- Connect the connectors.

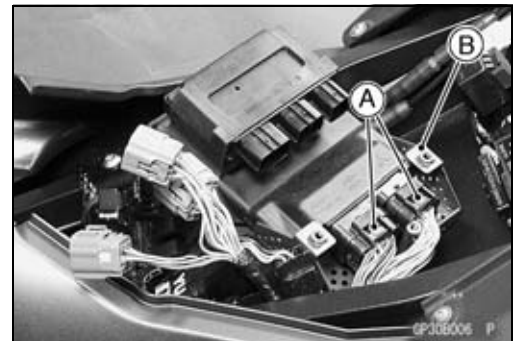

- Install:
  - Upper Guard Bracket [A]

<b>CAUTION</b>
----------------

<b>Do not pinch the leads.</b>
--------------------------------

- Tighten new screws [B] use Kawasaki genuine screws of which threads are coated with locking agent.

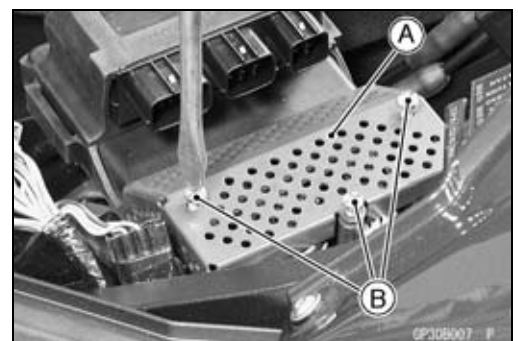

## 16-92 ELECTRICAL SYSTEM

### Immobilizer System (Equipped Models)

#### Immobilizer Relational Parts Replacement Chart

		Failed or Lost Part					
		Master Key (Red)	User Key (Black)	Ignition Switch	Antenna	Amplifier	ECU
*	Master Key (Red)	●					
	User Key (Black)		●	○			
	Ignition Switch			●			
	Antenna				●		
	Amplifier					●	
	ECU	○					●
*	Replacement Part						
●	Main Replacement Part						
○	Additional Replacement Part						

#### *Immobilizer System Inspection*

- Refer to the Immobilizer Amplifier and Blank Key Detection section in Fuel System (DFI) chapter.



# 16-94 ELECTRICAL SYSTEM

## Switches and Sensors

### Brake Light Timing Inspection

- Refer to the Brake Light Switch Operation Inspection in the Periodic Maintenance chapter.

### Brake Light Timing Adjustment

- Refer to the Brake Light Switch Operation Inspection in the Periodic Maintenance chapter.

### Switch Inspection

- Using a hand tester, check to see that only the connections shown in the table have continuity (about zero ohms).
- For the handlebar switches and the ignition switch, refer to the tables in the Wiring Diagram.
- ★ If the switch has an open or short, repair it or replace it with a new one.

**Special Tool - Hand Tester: 57001-1394**



### Rear Brake Light Switch Connections

	BR	BL
When brake pedal is pushed down		
When brake pedal is released		

### Side Stand Switch Connections

	G	BK
When side stand is up		
When side stand is down		

### Oil Pressure Switch Connections\*

	SW. Terminal	
When engine is stopped		
When engine is running		

\*: Engine lubrication system is in good condition



## Switches and Sensors

### Water Temperature Sensor Inspection

- Remove the water temperature sensor (see Fuel System (DFI) chapter).
- Suspend the sensor [A] in a container of coolant so that the temperature-sensing projection [E] and threaded portion [E] are submerged.
- Suspend an accurate thermometer [B] in the coolant.

#### NOTE

- The sensor and thermometer must not touch the container side or bottom.
- Place the container over a source of heat and gradually raise the temperature of the coolant while stirring the coolant gently.
- Using the hand tester, measure the internal resistance of the sensor.
- The sensor sends electric signals to the ECU (Electronic Control Unit) and coolant temperature gauge in the meter unit.
- Measure the resistance across the terminals and the body (for the gauge) at the temperatures shown in the table.
- ★ If the hand tester does not show the specified values, replace the sensor.

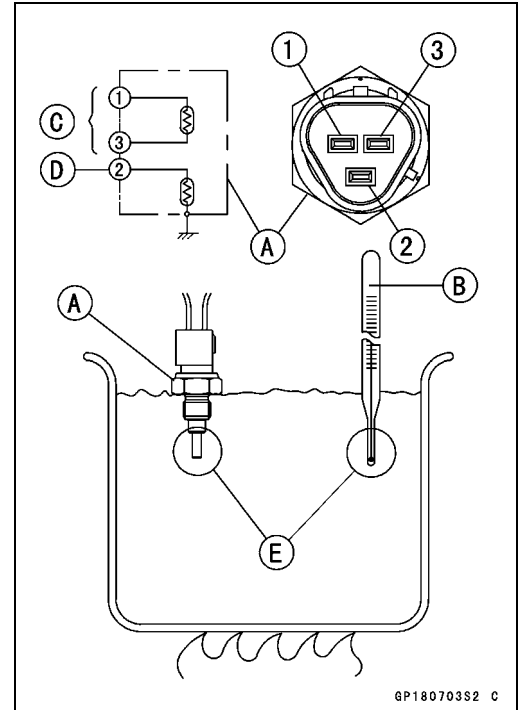

### Water Temperature Sensor

Resistance for ECU [C]	
Temperature	Resistance (kΩ) (Terminal [1]-[3])
20°C (68°F)	2.46 +0.115 -0.143
80°C (176°F)	0.32 ±0.011
110°C (230°F)	0.1426 ±0.0041

Resistance for Water Temperature Gauge [D]	
Temperature	Resistance (Ω) (Terminal [2]-Body)
50°C (122°F)	210 ±40
120°C (248°F)	21.2 ±1.5

### Speed Sensor Removal

- Remove:
  - Lower Fairing (see Frame chapter)
- Disconnect the speed sensor lead connector [A].
- Remove the speed sensor bolt [B].
- Remove the speed sensor [C].

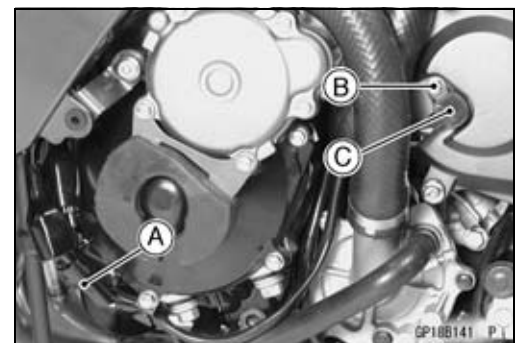

### Speed Sensor Installation

- Apply a non-permanent locking agent to the sensor bolt.
- Install the speed sensor.

**Torque - Speed Sensor Bolt: 4.0 N·m (0.40 kgf·m, 35 in·lb)**

# 16-96 ELECTRICAL SYSTEM

## Switches and Sensors

### Speed Sensor Inspection

- Remove:
  - Speed Sensor (see this chapter)
- Connect the speed sensor connector [A] with the battery [B], 10 kΩ resistor [C] and hand tester [D] as shown.
- Set the tester to the DC 25 V range.

**Special Tool - Hand Tester: 57001-1394**

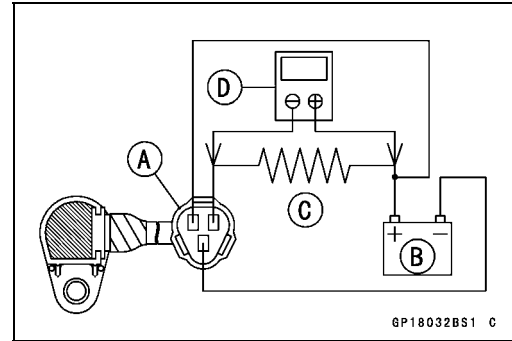

- Trace [A] each side of the speed sensor surface with the screw driver.
- Then the tester indicator should flick [B].
- ★ If the tester indicator does not flick, replace the speed sensor.

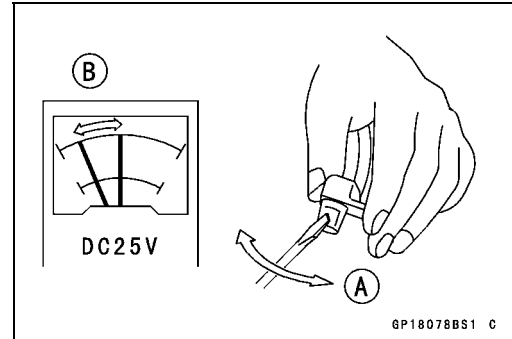

### Fuel Reserve Switch Inspection

- Fill the fuel tank with fuel.
- Close the fuel tank cap surely.
- Remove the fuel tank (see Fuel System (DFI) chapter).
- Connect the test light [A] (12 V 3.4 W bulb in a socket with leads) and the 12 V battery [B] to the fuel pump connector [C].

#### Connections

**Battery (+) → 12 V 3.4 W Bulb (one side)**

**12 V 3.4 W Bulb (other side) → R/BK Lead Terminal**

**Battery (-) → BK/W Lead Terminal**

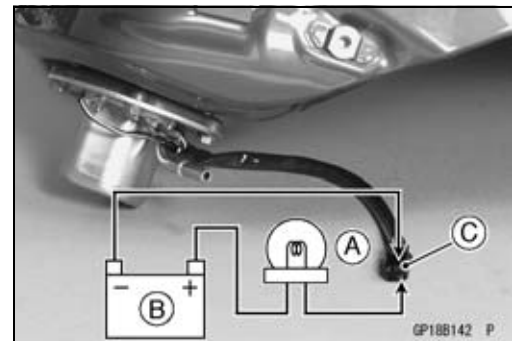

**Special Tool - Needle Adapter Set: 57001-1457**

- ★ If the test light turn on, the reverse switch is defective. Replace the fuel pump.

- Remove:
  - Fuel Pump (see Fuel System (DFI) chapter)
- Connect the test light (12 V 3.4 W bulb in a socket with leads) and the 12 V battery to the fuel pump connector as shown.

12 V Battery [A]

Test Light [B]

Fuel Pump Connector [C]

Fuel Reserve Switch [D]

- ★ If the test light doesn't light, replace the fuel pump.

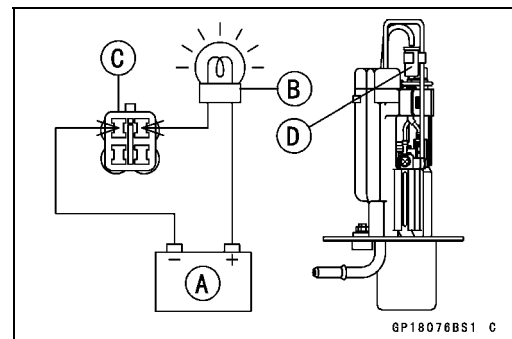

### NOTE

○ It may take a long time to turn on the test light in case that the fuel reserve switch is inspected just after the fuel pump is removed. Leave the fuel reserve switch with leads for inspection connected for few minutes.

**Switches and Sensors**

*Gear Position Switch Removal*

- Remove:
  - Middle Fairings (see Frame chapter)
  - Muffler (see Engine Top End chapter)
  - Dust Cover (Slide out) [A]
  - Oil Pressure Lead [B]
  
- Remove:
  - Seats (see Frame chapter)
  - Fuel Tank (see Fuel System (DFI) chapter)
  - Fuse Hose [A]
  - Screw [B]
  - Gear Position Switch Connector [C]

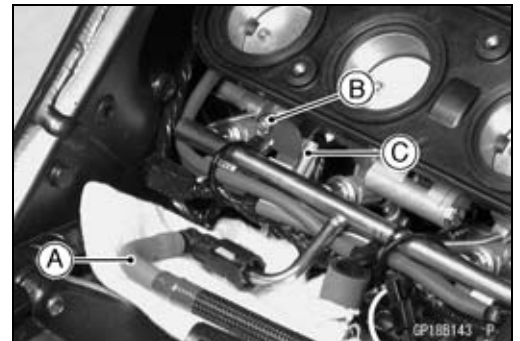
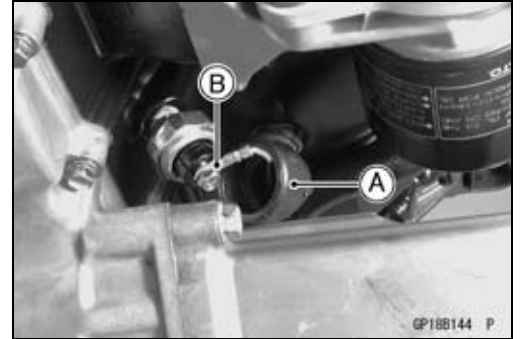

- Remove:
  - Engine Sprocket Cover (see Final Drive chapter)
  - Clamp (open) [A]
  - Screws [B]
  - Gear Position Switch [C]
  - Pin
  - Spring

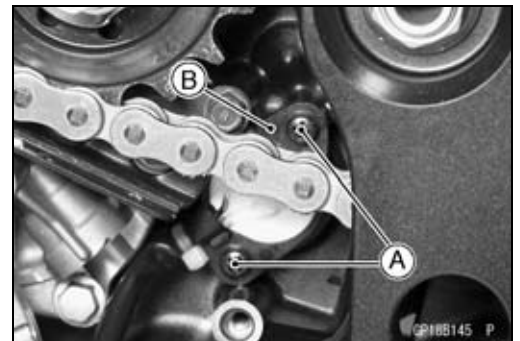

*Gear Position Switch Installation*

- Securely place the spring [A] and pin [B] into the hole [C] of the shift drum.
- Apply grease to the O-ring [D] and install the gear position switch.
- Apply a non-permanent locking agent to the gear position switch screws.

**Torque - Gear Position Switch Screws: 4.9 N·m (0.50 kgf·m, 43 in·lb)**

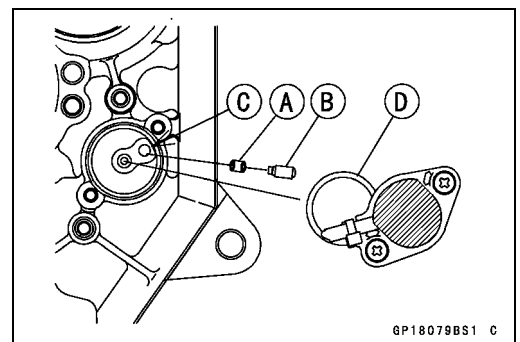

- Run the gear position switch lead [A] to the hole [B] of the heat insulation rubber plate [C].
- Connect:
  - Gear Position Switch Lead Connector
  - Oil Pressure Switch Lead (see Engine Lubrication System chapter)
- Install other removed parts.

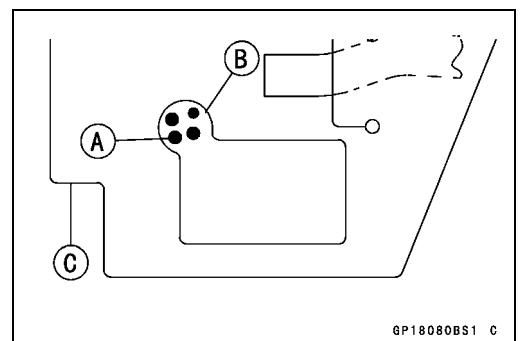

# 16-98 ELECTRICAL SYSTEM

## Switches and Sensors

### Gear Position Switch Inspection

**NOTE**

○Be sure the transmission mechanism is good condition.

- Remove:
  - Seats (see Frame chapter)
  - Fuel Tank (see Fuel System chapter)
  - Fuel Hose [A]
  - Screw [B]
- Disconnect the gear position switch lead connector [C].
- Set the hand tester [A] to the 1 kΩ or × 100 Ω range and connect it to the terminals in the gear position switch lead connector [B] and ground.
  - [C] Internal Circuit
  - [1] Green Lead
  - [2] Blue Lead
  - [3] Black Lead

**Special Tool - Hand Tester: 57001-1394**

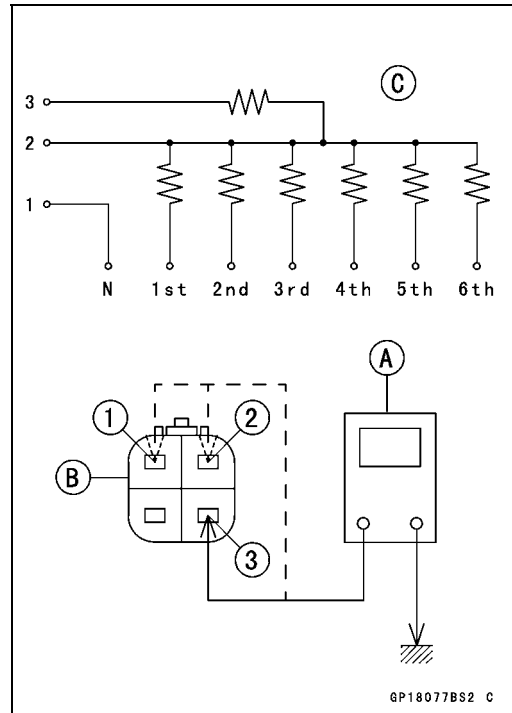
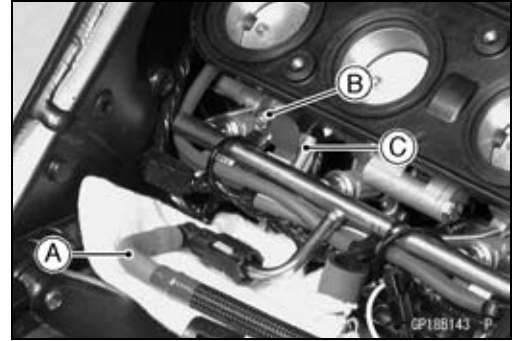

### Gear Position Switch Resistance

kΩ

Gear Position	Connections		
	1-Ground	2-Ground	3-Ground
Neutral	about 0	—	—
1st	—	3.00 ~ 3.32	11.63 ~ 12.87
2nd	—	1.70 ~ 1.89	10.33 ~ 11.44
3rd	—	1.07 ~ 1.19	9.70 ~ 10.74
4th	—	0.695 ~ 0.769	9.32 ~ 10.32
5th	—	0.430 ~ 0.476	9.06 ~ 10.03
6th	—	0.248 ~ 0.274	8.89 ~ 9.81

★ If the tester reading is not as specified, replace the gear position switch with a new one.

## Relay Box

The relay box [A] has relays and diodes. The relays and diodes can not be removed.

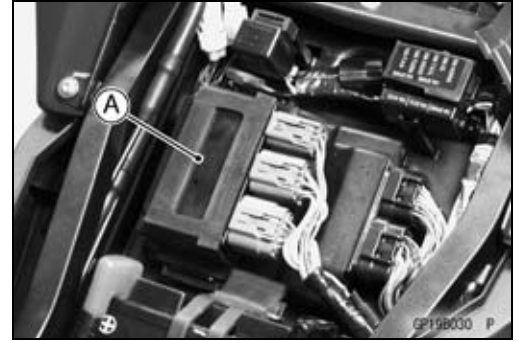

### Relay Box Removal

- Remove:
  - Seats (see Frame chapter)
- Take out the relay box [A] and disconnect the connectors [B].

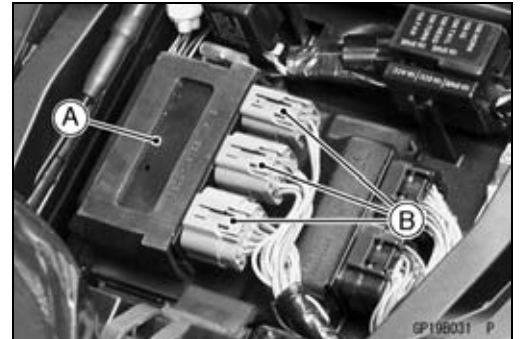

### Relay Circuit Inspection

- Remove the relay box.
- Check conductivity of the following numbered terminals by connecting the hand tester and one 12 V battery to the relay box as shown (see Relay Box Internal Circuit).
- ★ If the tester does not read as specified, replace the relay box.

#### Relay Circuit Inspection (with the battery disconnected)

	Tester Connection	Tester Reading ( $\Omega$ )
Headlight Relay	11-16	$\infty$
ECU Main Relay	12-13	$\infty$
	5-10	Not $\infty^*$
Fuel Pump Relay	12-14	$\infty$
	1-7	Not $\infty^*$
Starter Circuit Relay	6-9	$\infty$
	3-9	$\infty$
Fan Relay	17-19	$\infty$
	18-20	Not $\infty^*$

\*: The actual reading varies with the hand tester used.

# 16-100 ELECTRICAL SYSTEM

## Relay Box

### Relay Circuit Inspection (with the battery connected)

	Battery Connection		Tester Connection	Tester Reading ( $\Omega$ )
	(+)	(-)		
ECU Main Relay	15-9		11-16	0
	5-10		12-13	0
Fuel Pump Relay	7-1		12-14	0
Fan Relay	18-20		17-19	0

	Battery Connection		Tester Connection DC 25 V Range	Tester Reading (V)
	(+)	(-)		
Starter Circuit Relay	6-3		9-3	Battery Voltage

(+): Apply positive lead.

(-): Apply negative lead.

### Diode Circuit Inspection

- Remove the relay box.
- Check conductivity of the following pairs of terminals (see Relay Box Internal Circuit).

### Diode Circuit Inspection

Tester Connection	2-3, 2-4, 3-4, 3-6, 4-8, 9-15, 9-16
-------------------	-------------------------------------

- ★ The resistance should be low in one direction and more than ten times as much in the other direction. If any diode shows low or high in both directions, the diode is defective and the relay box must be replaced.

### NOTE

○ The actual meter reading varies with the meter or tester used and the individual diodes, but generally speaking, the lower reading should be from zero to one half the scale.

Relay Box

Relay Box Internal Circuit

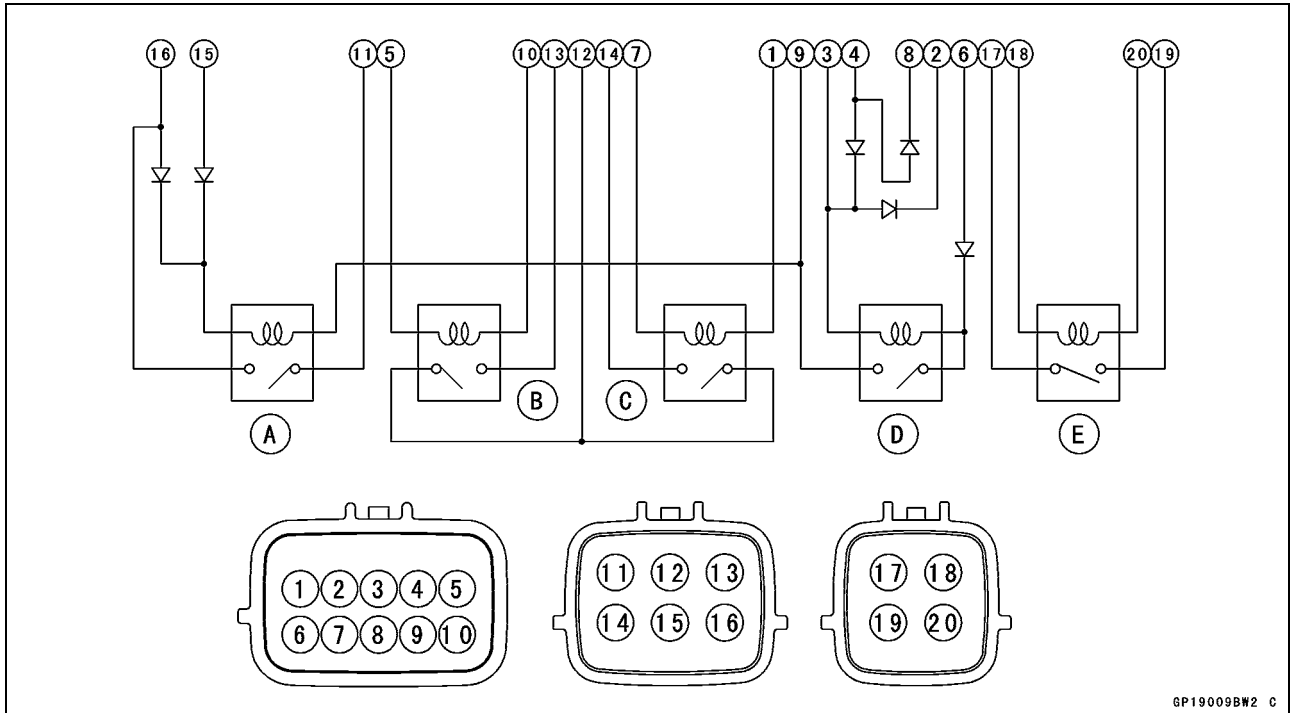

GP19009BW2 C

- A. Headlight Relay
- B. ECU Main Relay
- C. Fuel Pump Relay
- D. Starter Circuit Relay
- E. Fan Relay

# 16-102 ELECTRICAL SYSTEM

## Fuse

### 30 A Main Fuse Removal

- Remove:
  - Seats (see Frame chapter)
  - Fuel Tank (see Fuel System (DFI) chapter)
  - Starter Relay and 30 A Main Fuse Connector [A] (Push [B])

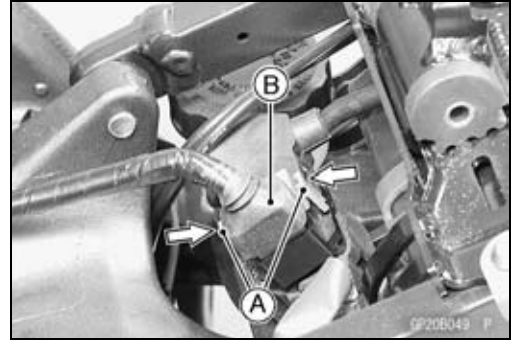

- Pull out the main fuse [A] from the starter relay with needle nose pliers.

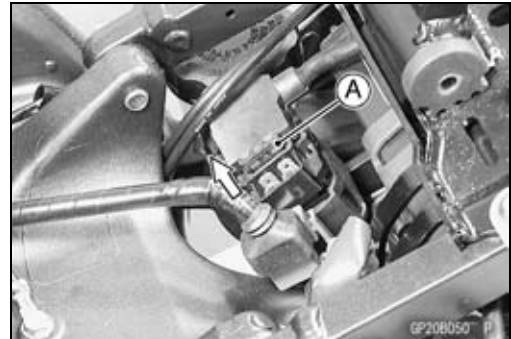

### Fuse Box Fuse Removal

- Remove the seats (see Frame chapter).
- Push the hook [A] to lift up the lid [B].

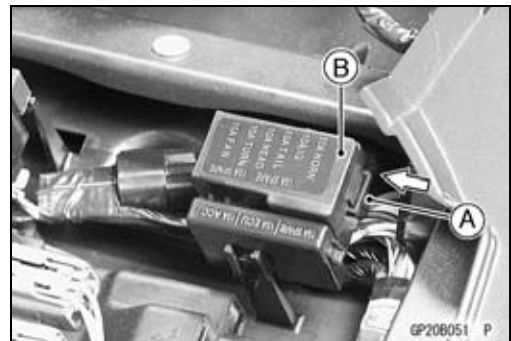

- Pull the fuses [A] straight out of the fuse box with needle nose pliers.

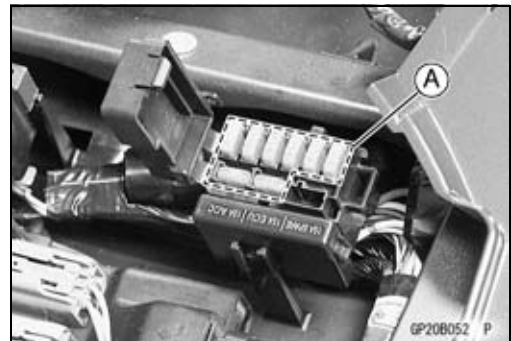

### 15 A ECU Fuse Removal

- Remove:
  - Seats (see Frame chapter)
- Pull the hook [A] to lift up the lid [B]

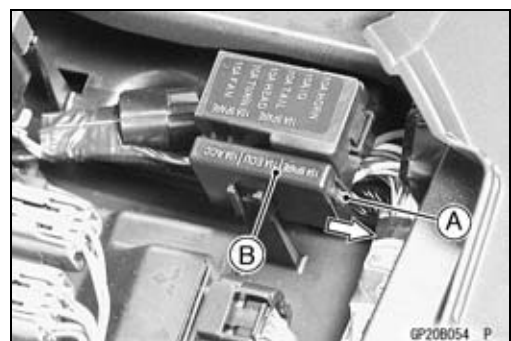



## Fuse

- Pull the ECU fuse [A] straight out of the fuse box with needle nose pliers.



### Fuse Installation

- If a fuse fails during operation, inspect the electrical system to determine the cause, and then replace it with a new fuse of proper amperage.
- Install the junction box fuses on the original position as specified on the lid.

### Fuse Inspection

- Remove the fuse (see Fuse Removal).
- Inspect the fuse element.
- ★ If it is blown out, replace the fuse. Before replacing a blown fuse, always check the amperage in the affected circuit. If the amperage is equal to or greater than the fuse rating, check the wiring and related components for a short circuit.

Housing [A]

Fuse Element [B]

Terminals [C]

Blown Element [D]

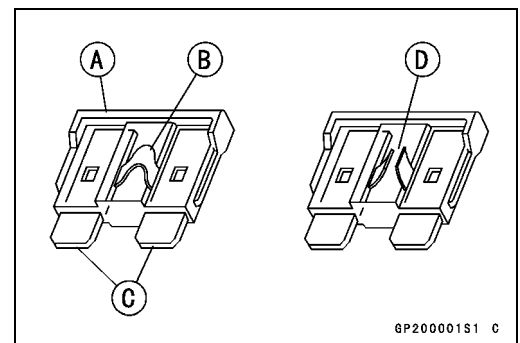

### NOTE

- If a mass current flows to the battery which needs re-freshing charge when the engine is turned, the main fuse may be blown out.

### CAUTION

When replacing a fuse, be sure the new fuse matches the specified fuse rating for that circuit. Installation of a fuse with a higher rating may cause damage to wiring and components.



# Appendix

## Table of Contents

Cable, Wire, and Hose Routing ..... 17-2  
Troubleshooting Guide ..... 17-28

# 17-2 APPENDIX

## Cable, Wire, and Hose Routing

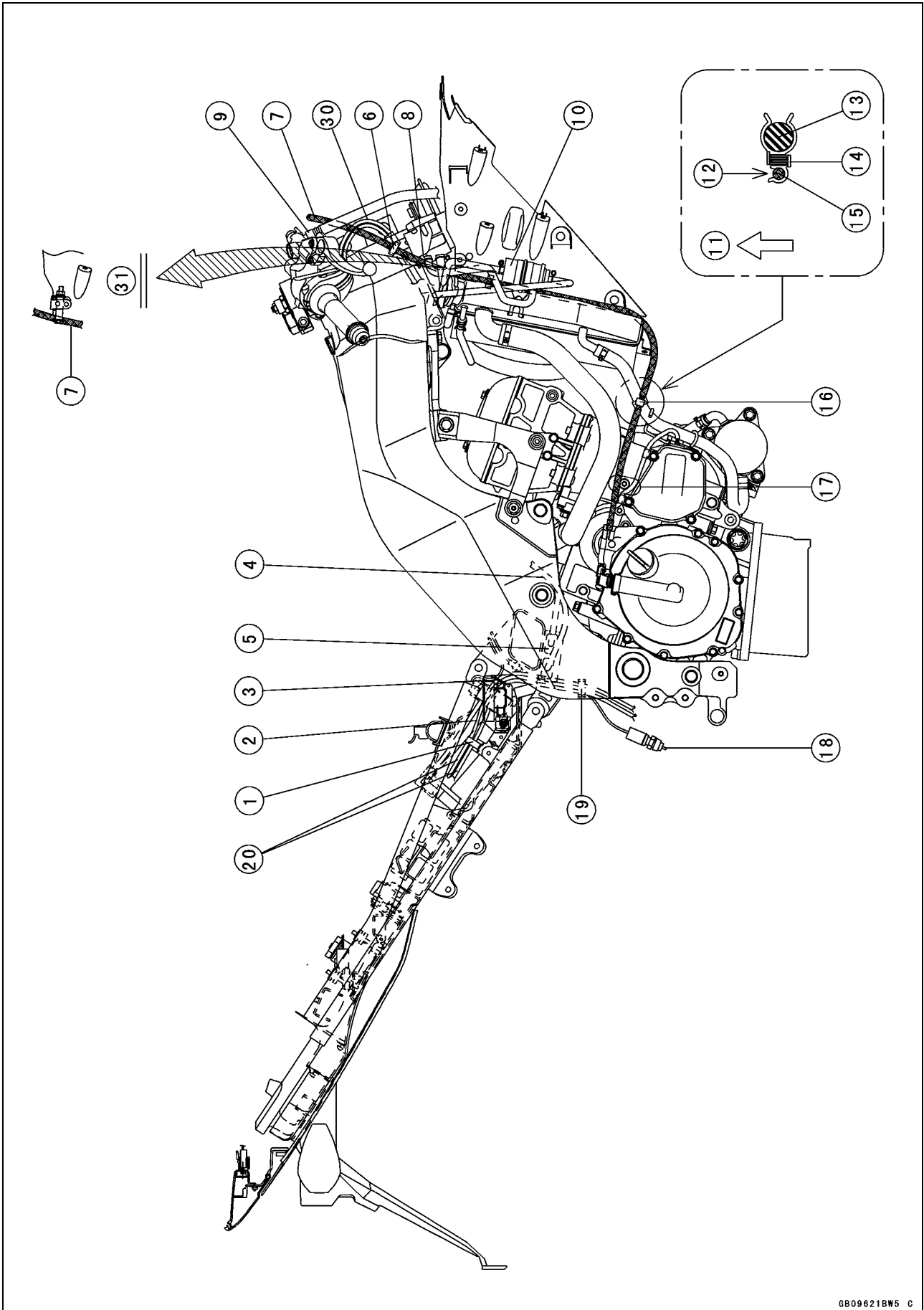

## Cable, Wire, and Hose Routing

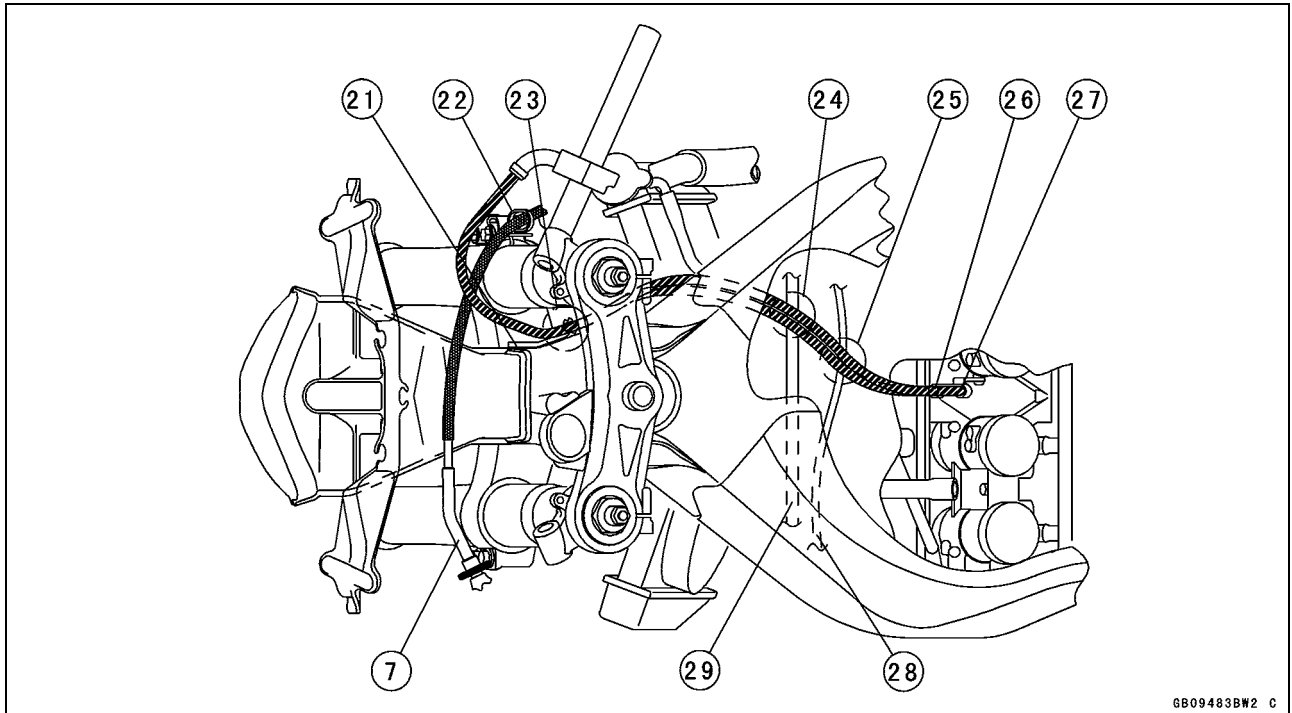

1. Clamp (Clamp the exhaust butterfly valve cables.)
2. Exhaust Butterfly Valve Cables
3. Clamp (Clamp the exhaust butterfly valve cables and starter relay lead.)
4. Run the regulator/rectifier leads under the engine mounting bolt.
5. Regulator/rectifier
6. Clamp (Install the clamp to the under bracket.)
7. Clutch Cable
8. Run the clutch cable between the separator (with its hoses) and inner fairing.
9. Brake Hose
10. Separator
11. Upward
12. Position the opening of the clamp upper side.
13. Radiator Hose
14. Clamp
15. Clutch Cable
16. Clamp
17. Run the crankshaft sensor lead under the boss of the fairing bracket.
18. Rear Brake Light Switch
19. Clamp (Clamp the exhaust butterfly valve cables first, next clamp the rear brake light switch lead.)
20. Exhaust Butterfly Valve Cables
21. Clamp
22. Clamp
23. Clamp the throttle cables under the right switch housing lead.
24. Run the throttle cables over the evaporative hose (California Model only).
25. Run the throttle cables over the stick coil harness.
26. Throttle Cable (Accelerator)
27. Throttle Cable (Decelerator)
28. Stick Coil Harness (Engine Subharness)
29. Evaporative Hose (California Model only)
30. Throttle Cables
31. Clutch Cable routing due to the bolt added to fix the clutch cable guide (Other than California model).

# 17-4 APPENDIX

## Cable, Wire, and Hose Routing

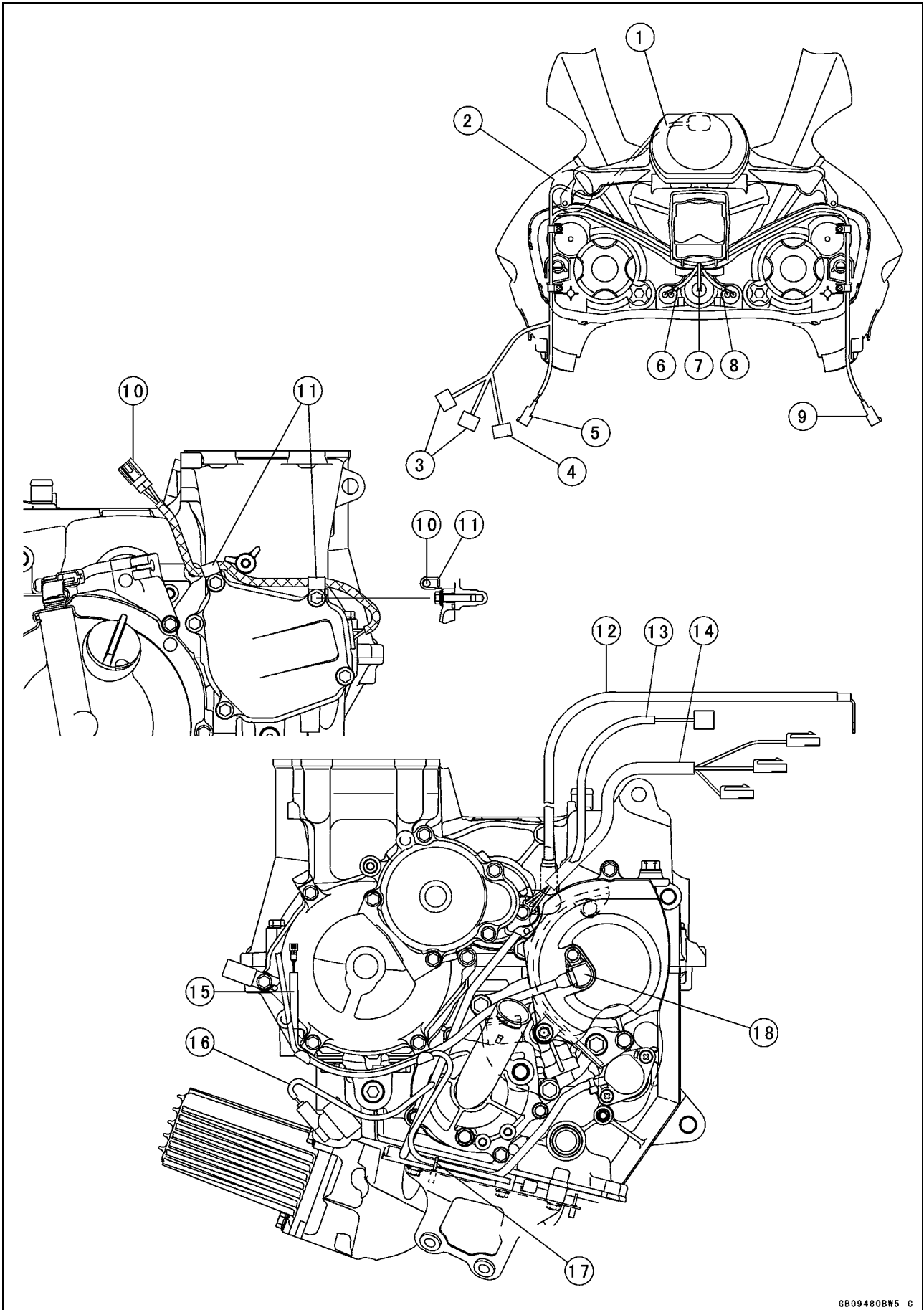

---

**Cable, Wire, and Hose Routing**

---

1. Meter Lead
2. Run the meter lead under the bracket.
3. Connect the connectors to the connector of the main harness (connected the connectors, insert the bracket.)
4. Connect the connector to the immobilizer amplifier.
5. To Front Left Turn Signal Light Connector
6. Left City Light Lead
7. Head Light Lead
8. Right City Light Lead
9. To Front Right Turn Signal Light Connector
10. Crankshaft Sensor Lead
11. Clamps
12. Starter Cable
13. Gear Position Switch and Oil Pressure Switch Lead
14. Alternator Lead
15. Speed Sensor Lead
16. Run the oil pressure sensor lead upward.
17. Clamp (Clamp the speed sensor and side stand switch leads.)
18. Speed Sensor

# 17-6 APPENDIX

## Cable, Wire, and Hose Routing

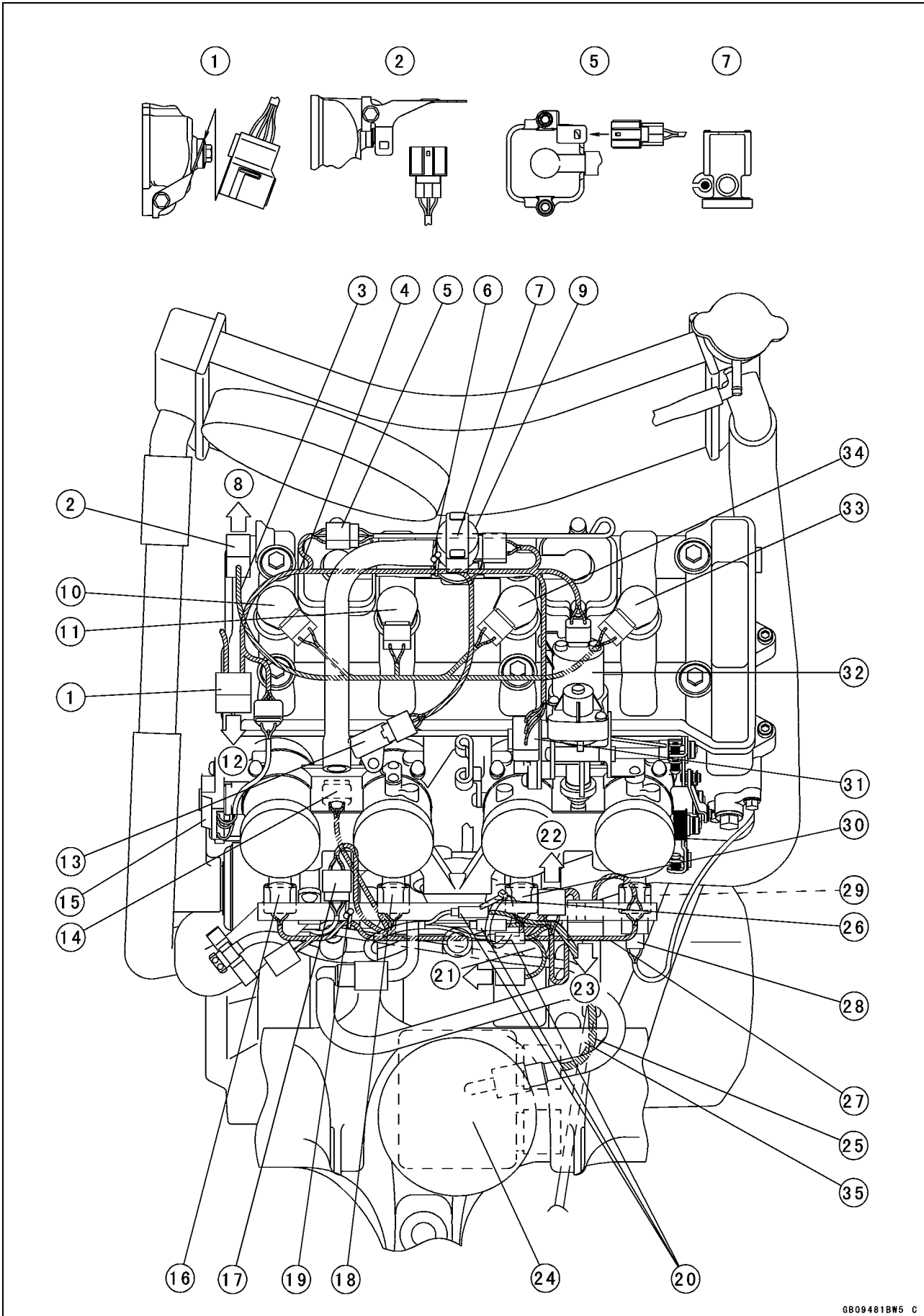



---

**Cable, Wire, and Hose Routing**

---

1. Put the joint connector onto the bracket.
2. Put the joint connector onto the bracket.
3. Stick Coil Harness
4. Engine Subharness
5. Put the camshaft position sensor lead connector onto the bracket.
6. Clamp (Clamp the vent hose and engine subharness.)
7. Run the engine subharness to the clamp portion of the air switching valve.
8. To the Main Harness Connector
9. Air Switching Valve
10. Stick Coil #1
11. Stick Coil #2
12. To the Main Harness Connector
13. Inlet Air Pressure Sensor
14. Water Temperature Sensor Lead Connector
15. Main Throttle Sensor
16. Fuel Injector #1
17. Gear Position Sensor and Oil Pressure Switch Lead Connector
18. Fuel Injector #2
19. Clamp
20. Alternator Lead Connector
21. To the Main Harness Connector
22. Install the inlet air temperature sensor onto the air cleaner housing.
23. To the Main Harness Connector
24. Regulator/rectifier
25. Regulator/rectifier Lead
26. Band (Clamp the alternator leads, throttle body harness and delivery pipe within the 5 notch of the band.)
27. Throttle Body Harness
28. Crankshaft Sensor Lead Connector
29. Fuel Injector #4
30. Fuel Injector #3
31. Subthrottle Sensor
32. Subthrottle Valve Actuator
33. Stick Coil #4
34. Stick Coil #3
35. Run the starter motor cable under the engine mounting bolt.

# 17-8 APPENDIX

## Cable, Wire, and Hose Routing

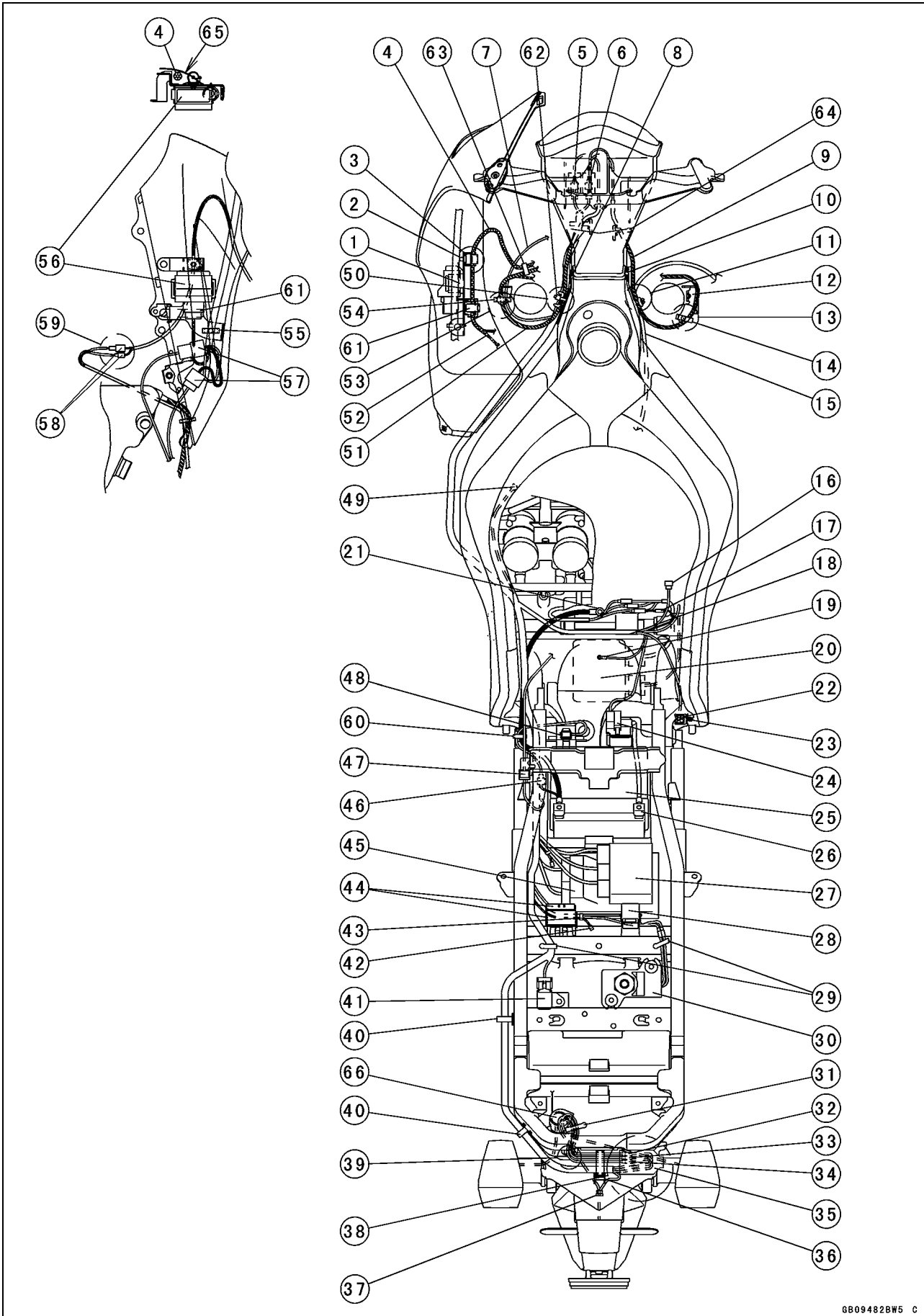

---

**Cable, Wire, and Hose Routing**

---

1. Bracket (Install the bracket into the upper fairing.)
2. Clamp the immobilizer antenna (Immobilizer System Model only) and ignition switch leads.
3. Clamp (Put the clamp onto the bracket.)
4. Ignition Switch Lead
5. Left Switch Housing Lead Connector
6. Right Switch Housing Lead Connector
7. Horn Lead
8. Clamp (Install the clamp with air duct.)
9. Right Switch Housing Lead
10. Clamp
11. Install the throttle cables under the right switch housing lead.
12. Clamp (Tighten it together with the steering stem.)
13. Clamp the right switch housing lead.
14. Clamp
15. Throttle Cables
16. To the Throttle Body Harness Joint Connector
17. Regulator/rectifier Harness
18. Draw up the lead to the cross bracket.
19. Frame Ground
20. Regulator/rectifier
21. Engine Ground
22. Run the rear brake switch lead inside the exhaust butterfly valve cables.
23. Clamp (Clamp the exhaust butterfly valve cables and rear brake light switch leads.)
24. Starter Relay
25. Battery 12 V 10 Ah
26. Battery Positive (+) Terminal
27. Relay Box
28. Turn Signal Relay
29. Clamps
30. Exhaust Butterfly Valve Actuator
31. Clamp
32. Rear Right Turn Signal Light Connector
33. License Plate Light Connector
34. Rear Left Turn Signal Light Connector
35. Rubber Boot
36. Clamp
37. Tail and Brake Light Connector
38. Cover the boot to the connectors after connecting the connector.
39. Run the leads to the cutted space of the rear fender rear.
40. Clamps (The clamp attached on the main harness.)
41. Atmospheric Pressure Sensor
42. Self-diagnosis Indicator Terminal
43. Immobilizer/Kawasaki Diagnostic System Connector
44. Fuse Box and Main ECU Fuse Box
45. ECU (Electric Control Unit)
46. Battery Negative (-) Terminal
47. Fuel Pump Lead Connector
48. Vehicle-down Sensor
49. To engine subharness connector
50. Run the main harness under the left switch housing lead.
51. Left Switch Housing Lead
52. To the Main Harness.
53. Clamp the left switch housing and horn leads.
54. Clamp (Install the clamp bracket onto the steering stem.)
55. Clamp
56. Immobilizer Amplifier
57. Headlight Harness Connectors
58. Immobilizer (Immobilizer System Model only) and Ignition Switch Lead Connectors
59. Install the connectors at this area.
60. Clamp (Clamp the battery cable and vehicle-down sensor lead.)
61. Clamp (Install the clamp with upper fairing.)
62. Band (Hold the left switch housing lead and main harness.)
63. Band (Hold the ignition switch lead and left switch housing lead.)
64. Clamp (Insert the clamp into the air duct.)
65. Install the clamp direction up light and bend it under side.
66. Fold the boot.

# 17-10 APPENDIX

## Cable, Wire, and Hose Routing

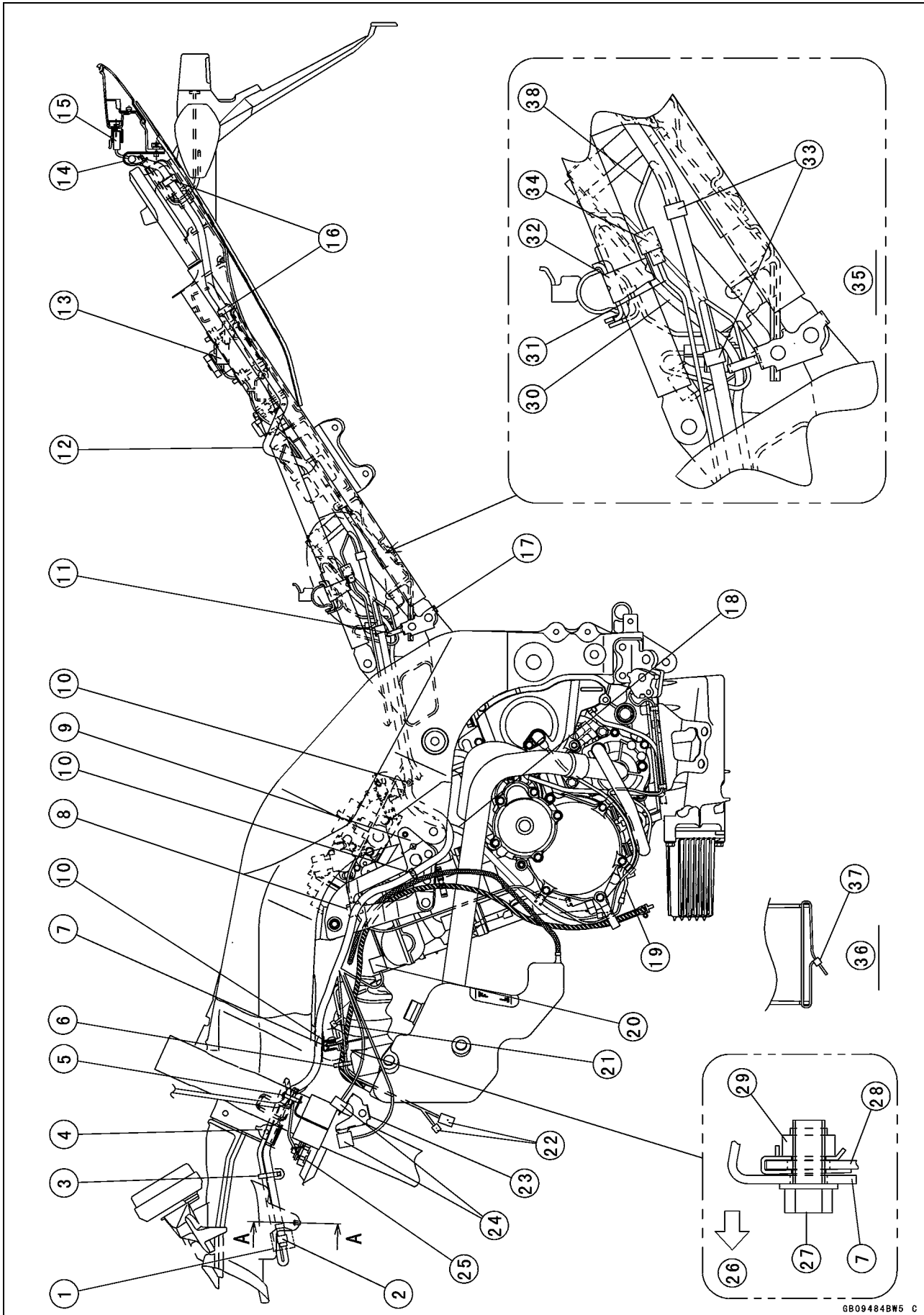

---

**Cable, Wire, and Hose Routing**

---

1. Install the rubber boot so that the wide opening faces front.
2. Left and Right Switch Housing Connectors
3. Clamp the gray color portion of the main harness (both sides).
4. Clamp (both sides)
5. Clamp (both sides)
6. Clamp (Clamp the immobilizer antenna/ignition switch lead and coolant reserve tank overflow hose.)
7. Bracket
8. Engine Subharness Joint Connector
9. Engine Bracket
10. Clamps (The clamps attached on the main harness.)
11. Clamp (Run the battery negative (–) cable and vehicle-down-sensor lead through the clamp.)
12. Run the main harness over the rear frame.
13. Atmospheric Pressure Sensor
14. Clamp (Install the clamp with the tail/brake light mounting screw.)
15. Tail/brake Light
16. Clamps (The clamps attached on the main harness.)
17. Bracket
18. Air Cleaner Drain Hose
19. Speed Sensor Lead
20. Stick Coil Harness Joint Connector
21. Fan Motor Connector
22. To the Immobilizer Antenna/ignition Switch Lead Connectors
23. Bracket (Install the bracket into the upper fairing.)
24. To the Headlight Harness Connectors
25. Horn
26. Front
27. Bolt
28. Radiator
29. Nut
30. Battery Negative (–) Cable
31. Fuel Pump Lead
32. Bracket
33. Install the joint connectors so that the connectors are outside of the frame.
34. Install the battery negative (–) lead connector inside of the fuel pump lead connector.
35. Detail
36. Section A-A
37. Band
38. Run the fuel pump harness divided from the main harness to rightside of main harness.

# 17-12 APPENDIX

## Cable, Wire, and Hose Routing

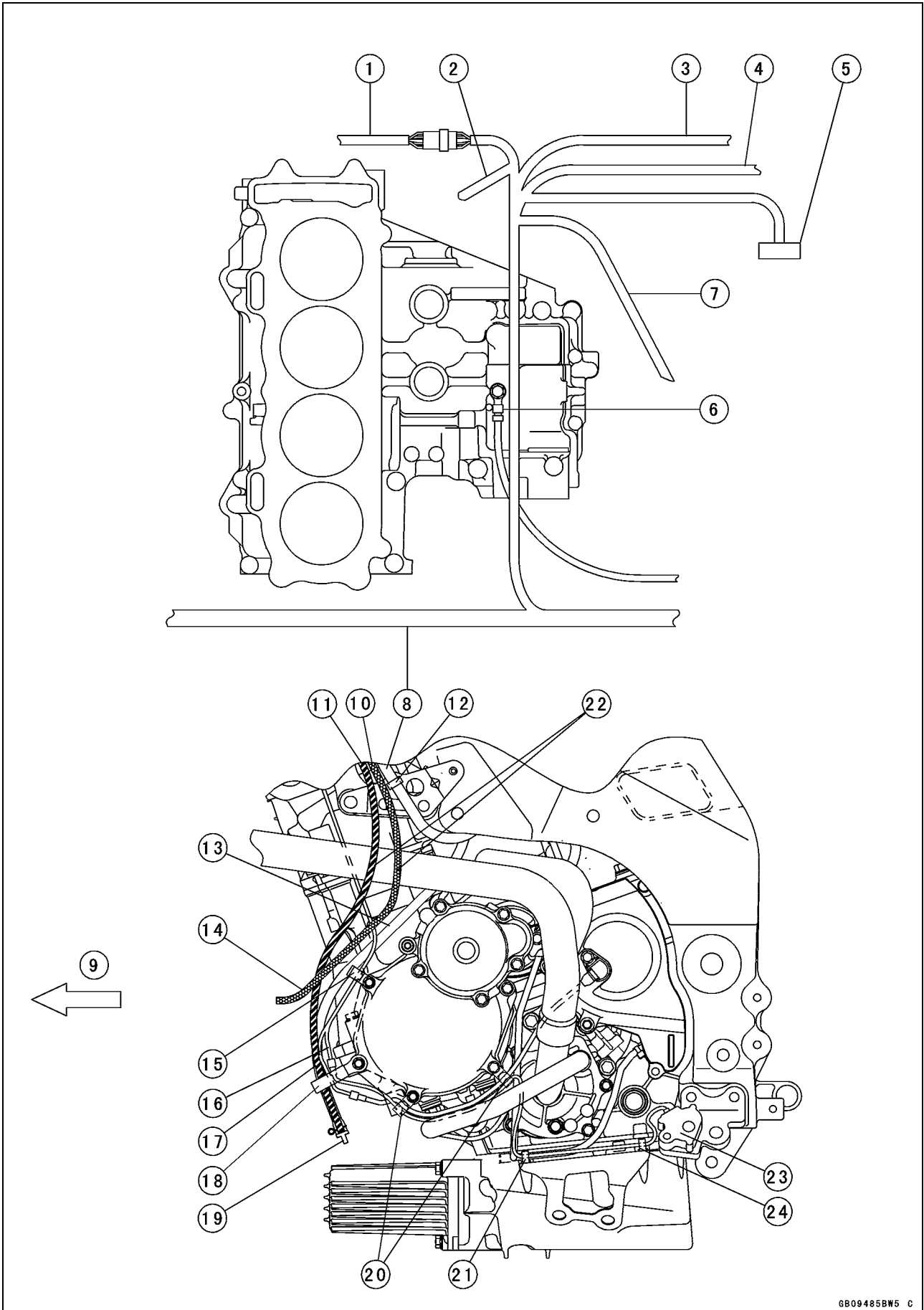

---

**Cable, Wire, and Hose Routing**

---

1. Throttle Body Harness
2. To the Alternator Lead
3. To the Rear Brake Switch Lead
4. To the Starter Relay
5. To the Regulator/rectifier
6. Engine Ground
7. To the Frame Ground
8. Main Harness
9. Front
10. Radiator Over Flow Hose
11. Reserve Tank Over Flow Hose
12. Inserted Clamp (Attached main harness.)
13. Air Cleaner Drain Hose
14. Reserve Tank Return Hose
15. Clamp
16. Side Stand Switch Lead Connector
17. Speed Sensor Lead Connector
18. Clamp
19. Plug
20. Clamps
21. Clamp (Hold the side stand switch lead and gear position switch lead.)
22. Run the hoses outside of the speed sensor and side stand switch leads.
23. Side Stand Switch
24. Clamp (Hold the side stand switch lead.)

## 17-14 APPENDIX

### Cable, Wire, and Hose Routing

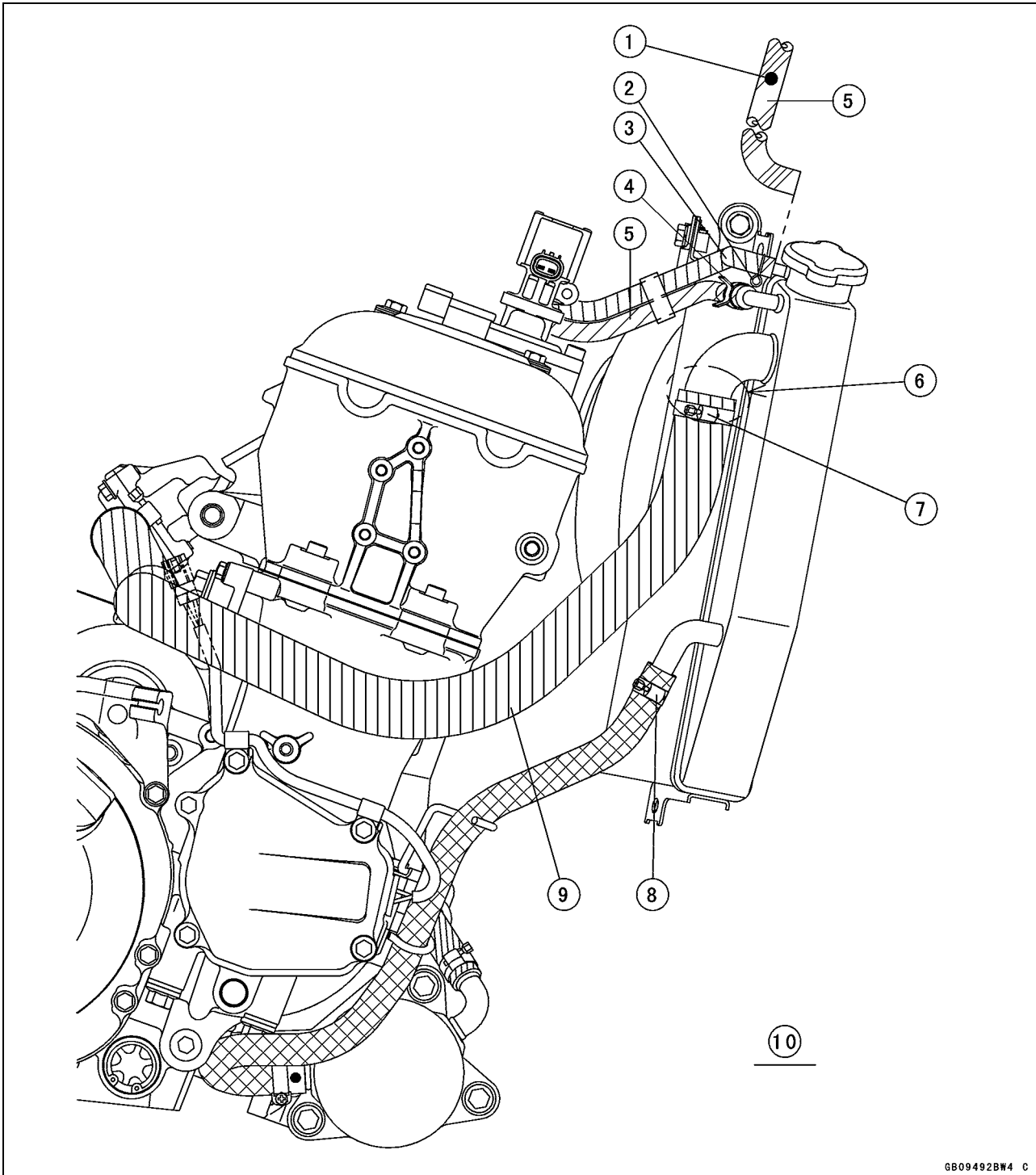

GB09492BW4 C

1. Paint Mark (White)
2. Clamp
3. Radiator Over Flow Hose
4. Clamp
5. Radiator Coolant Return Hose
6. Insert the radiator hose to the corner portion of the radiator pipe.
7. Clamp
8. Clamp
9. Radiator Hose
10. Install the clamps as shown illustration noting to the direction of clip.



Cable, Wire, and Hose Routing

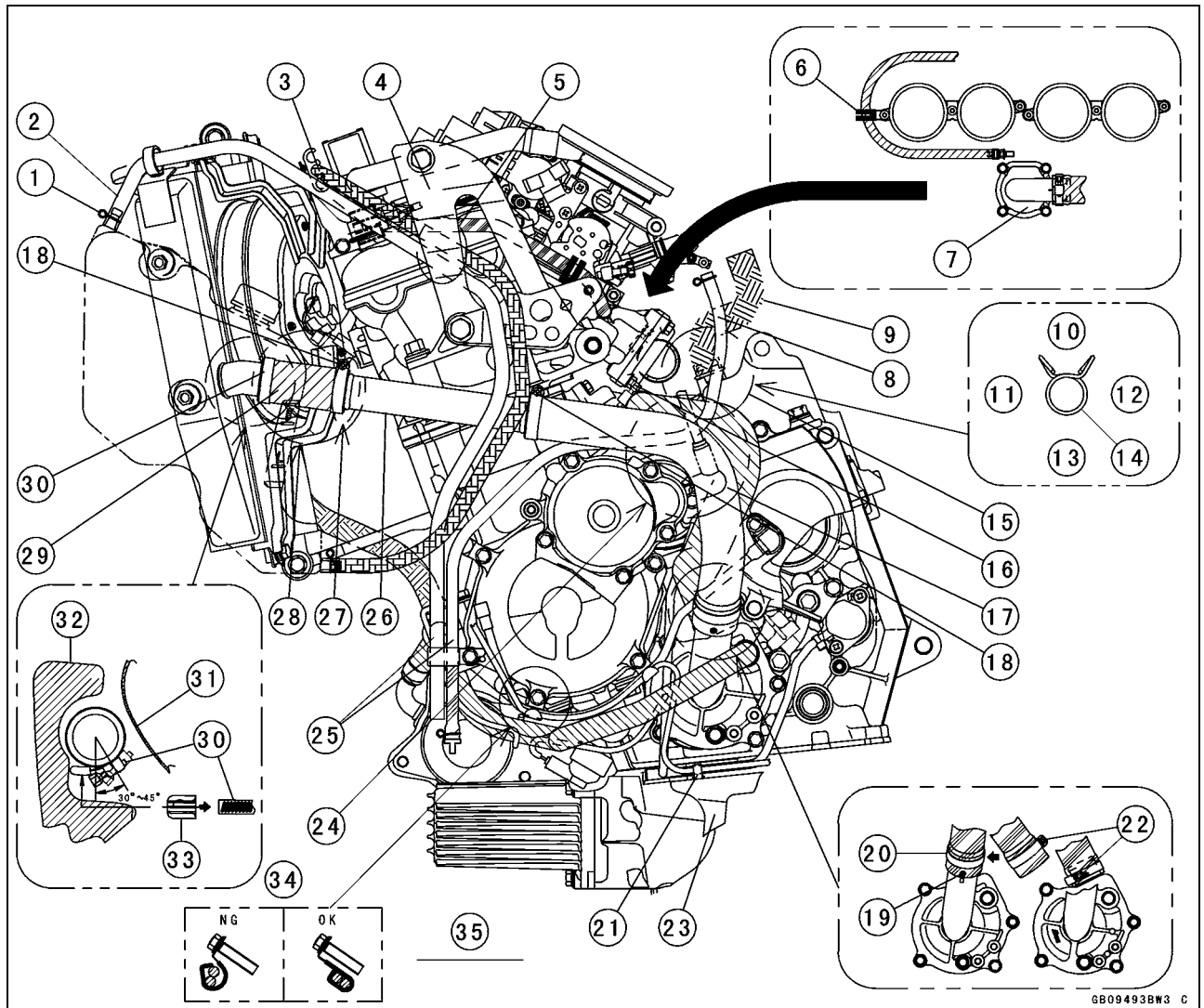

- |   |  |
|---|--|
| <ol style="list-style-type: none"> <li>1. Clamp</li> <li>2. Coolant Reserve Tank Over Flow Hose</li> <li>3. Radiator Coolant Return Hose</li> <li>4. Left Upper Engine Mounting Bracket</li> <li>5. Run the hoses inside the mounting bracket.</li> <li>6. Clamp</li> <li>7. Thermostat Housing</li> <li>8. Air Cleaner Housing Drain Hose</li> <li>9. Breather Hose</li> <li>10. Right</li> <li>11. Front</li> <li>12. Rear</li> <li>13. Left</li> <li>14. Clamp</li> <li>15. Install the breather hose so that the marked side of the hose faces to the right.</li> <li>16. Clamp</li> <li>17. Water Hose</li> <li>18. Clamp</li> </ol> | <ol style="list-style-type: none"> <li>19. Align the paint mark with the projection.</li> <li>20. Clamp</li> <li>21. Clamp</li> <li>22. Install the screw from backward.</li> <li>23. Guard Bracket</li> <li>24. Connect the water hose so that it does not touch to the starter idle gear cover.</li> <li>25. Run the hoses to the clamp.</li> <li>26. Water Pipe</li> <li>27. Insert the radiator hose to the swell portion of the radiator pipe.</li> <li>28. Connect the radiator hose so that it does not touch to the radiator.</li> <li>29. Radiator Hose</li> <li>30. Clamp</li> <li>31. Radiator Fan Net</li> <li>32. Coolant Reserve Tank</li> <li>33. Grommet</li> <li>34. Bend the clamp as shown.</li> <li>35. Install the clamps as shown illustration noting to the direction of clip.</li> </ol> |
|---|--|

## 17-16 APPENDIX

### Cable, Wire, and Hose Routing

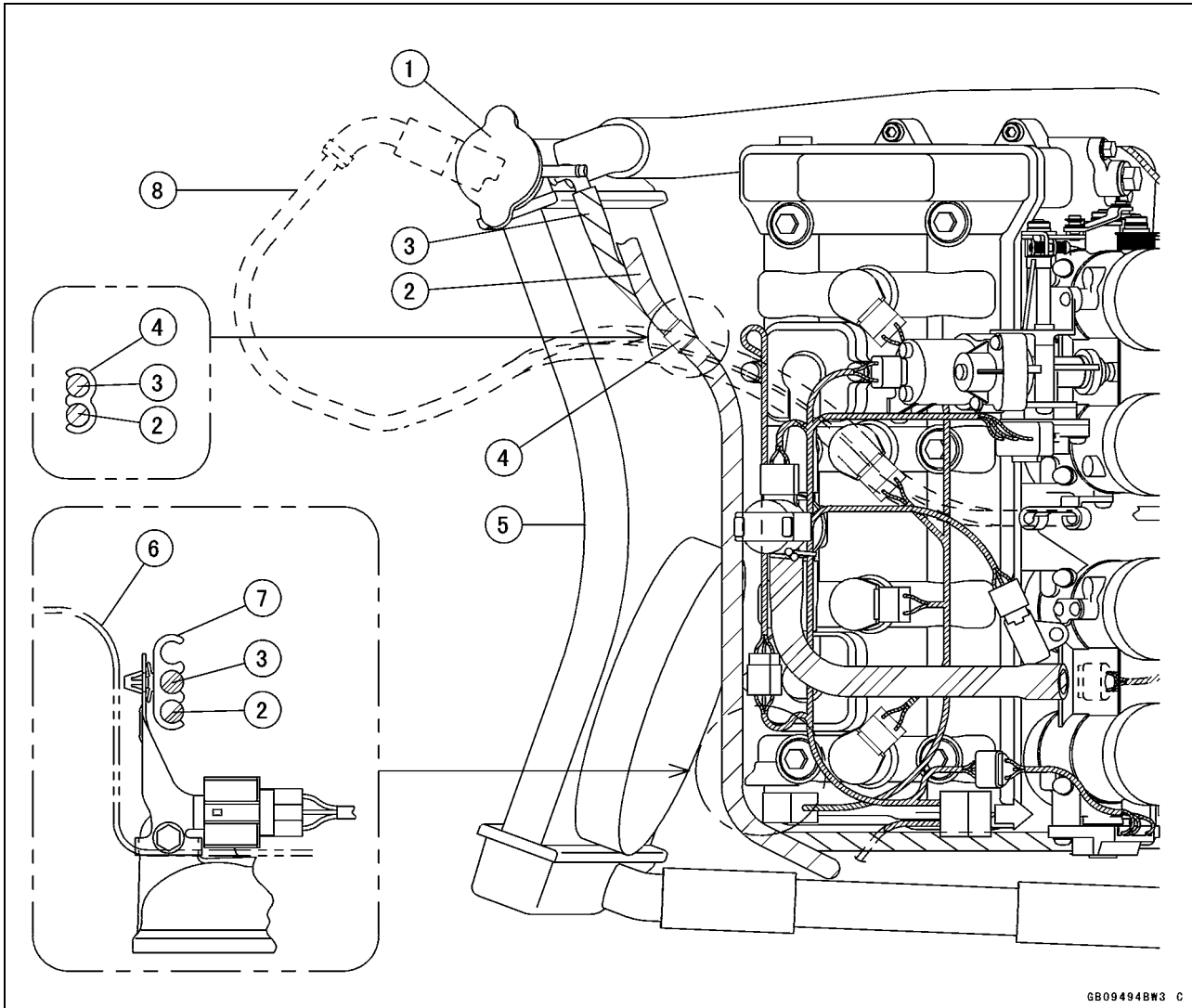

1. Radiator Cap
2. Coolant Return Hose
3. Thermostat Vent Hose
4. Clamp
5. Radiator
6. Run the hoses back the heat insulation rubber plate.
7. Clamp
8. Run the throttle cable above the harness and cooling hoses.

Cable, Wire, and Hose Routing

California Model

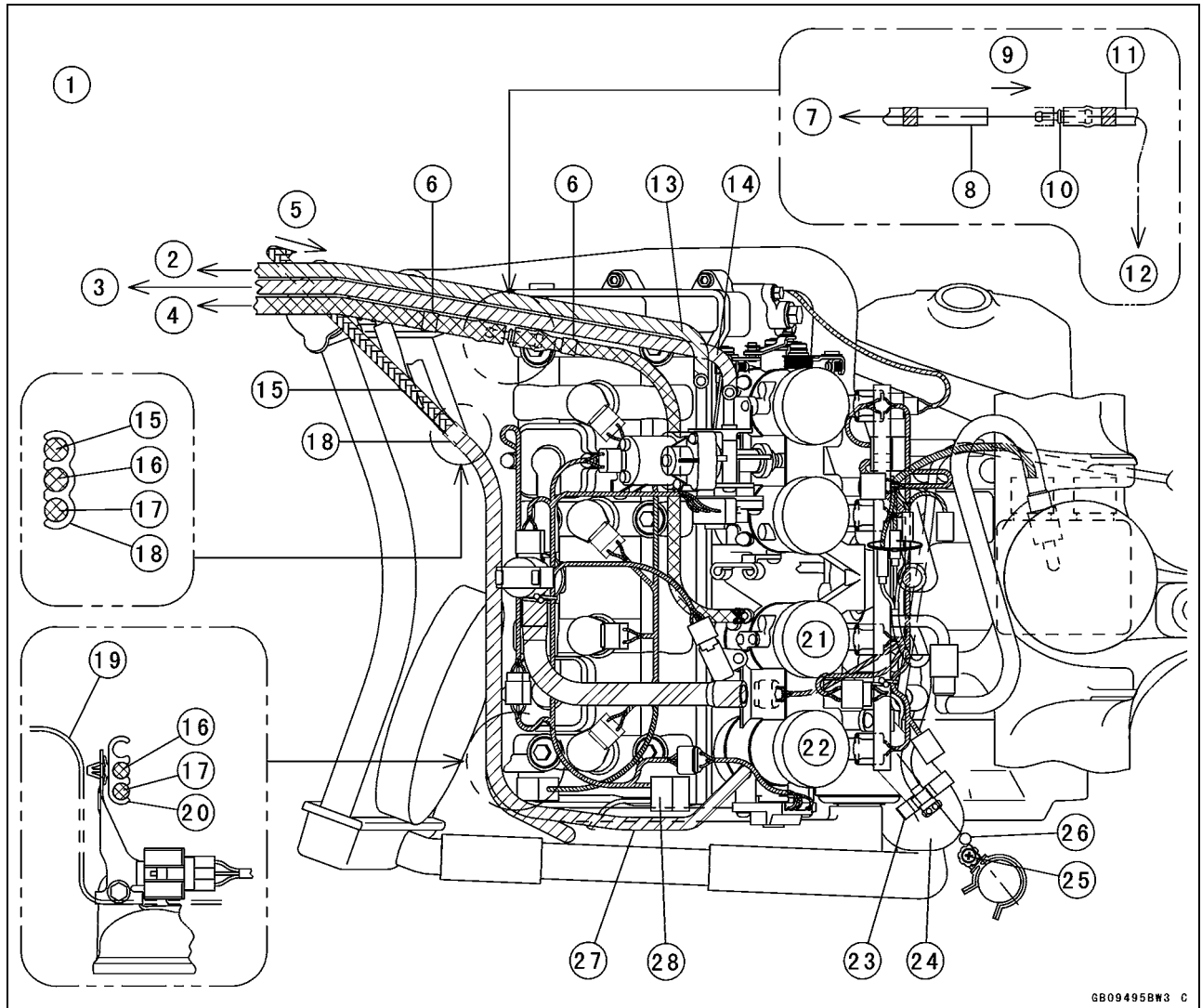

GB09495BW3 C

- |   |  |
|---|--|
| <ol style="list-style-type: none"> <li>1. California Model</li> <li>2. To the Separator</li> <li>3. To the Separator</li> <li>4. To the Canister</li> <li>5. To the Separator</li> <li>6. Marking Tape (Green)</li> <li>7. Install the hose to the canister before inserting it to the fitting.</li> <li>8. Hose (Green)</li> <li>9. Install the hose to the fitting after installing other ends of both hoses.</li> <li>10. Fitting</li> <li>11. Hose (Green)</li> <li>12. Install the hose to the #2 fitting of the throttle body before connecting it to other hoses.</li> <li>13. Hose (Red)</li> </ol> | <ol style="list-style-type: none"> <li>14. Hose (Blue)</li> <li>15. Hose (White)</li> <li>16. Coolant Return Hose</li> <li>17. Thermostat Vent Hose</li> <li>18. Clamp</li> <li>19. Run the hoses back the heat insulation rubber plate.</li> <li>20. Clamp</li> <li>21. Throttle Body #2</li> <li>22. Throttle Body #1</li> <li>23. Clamp</li> <li>24. Water Hose</li> <li>25. Install the idle adjuster direction as shown.</li> <li>26. Just Above</li> <li>27. Run the white hose outside the connector.</li> <li>28. Connector</li> </ol> |
|---|--|

# 17-18 APPENDIX

## Cable, Wire, and Hose Routing

### California Model

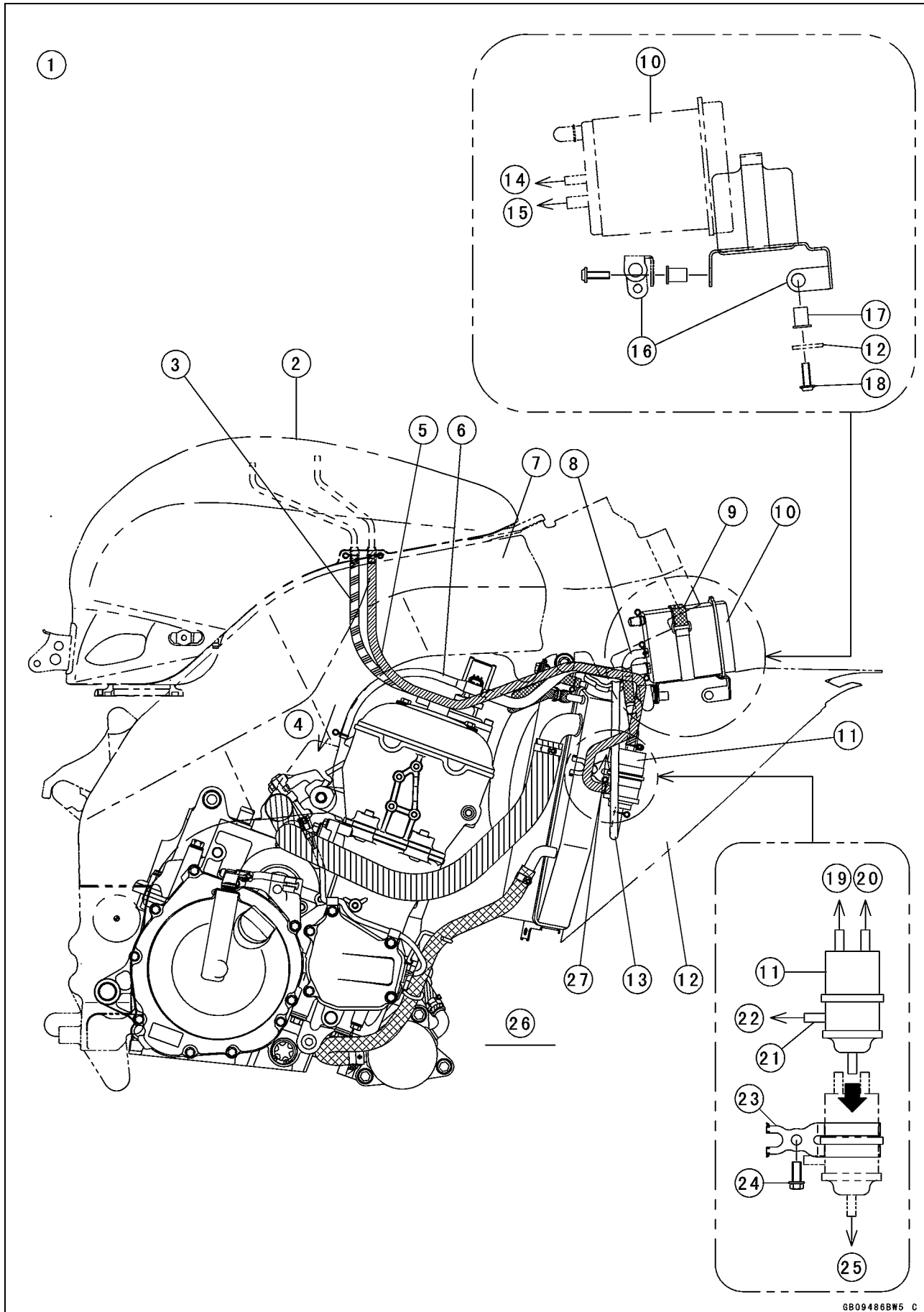

---

**Cable, Wire, and Hose Routing**

---

1. California Model
2. Fuel Tank
3. Hose (Blue)
4. To the Fitting of the Throttle Body #2
5. Hose (Red)
6. Hose (Green)
7. Frame
8. Hose (Blue)
9. Band
10. Canister
11. Separator
12. Left Inner Fairing
13. Hose (White)
14. To the 8
15. To the 6
16. Bracket
17. Nut
18. Bolt
19. To the 8
20. To the 3
21. Align the fitting direction with the mark of the hose.
22. To the 5
23. Bracket
24. Bolt
25. To the 13
26. Install the clamps direction as shown illustration.
27. Run the white hose inside of the red hose so that it should be not caught in the fairing.

# 17-20 APPENDIX

## Cable, Wire, and Hose Routing

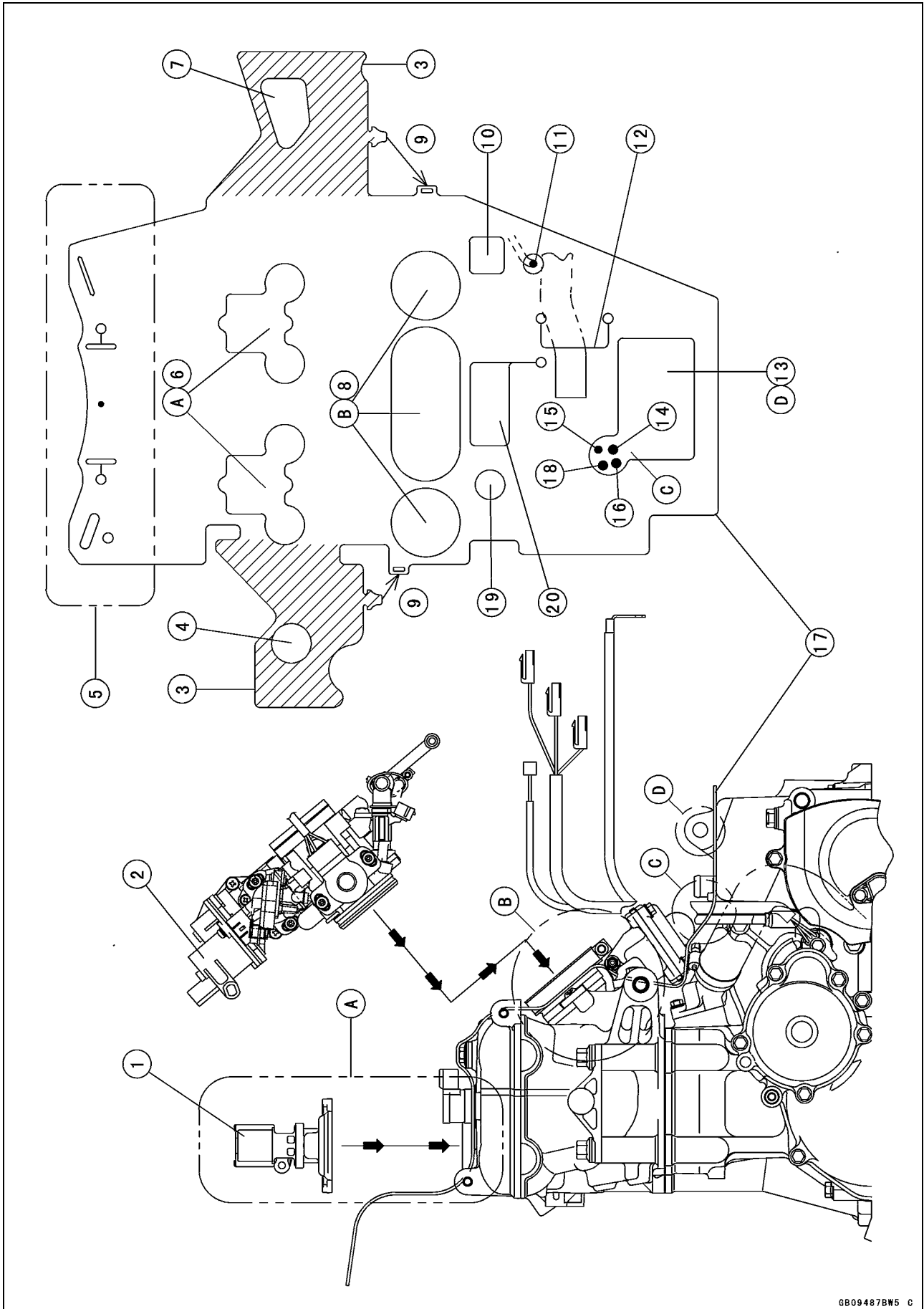

---

**Cable, Wire, and Hose Routing**

---

1. Air Switching Valve
2. Throttle Body Assy
3. Hang down the shaded portions of the heat insulation rubber plate.
4. For the Down Engine Mounting Bolt
5. For the Upper Portion of the Radiator.
6. For the Air Suction Valve Covers
7. For the Engine Mounting Bolt
8. For the Throttle Bodies
9. Install the hooks after installing the heat insulation rubber plate.
10. For the Engine Mounting Bolt
11. Crankshaft Sensor Lead
12. Install the radiator hose under the heat insulation rubber plate.
13. For the Engine Mounting Bolt, Breather Tube and Engine Ground
14. Alternator Lead
15. Starter Motor Lead
16. Gear Position Switch and Oil Pressure Switch Lead
17. Heat Insulation Rubber Plate
18. Idle Adjusting Cable
19. For the Water Temperature Sensor
20. For the Thermostat Housing

## 17-22 APPENDIX

### Cable, Wire, and Hose Routing

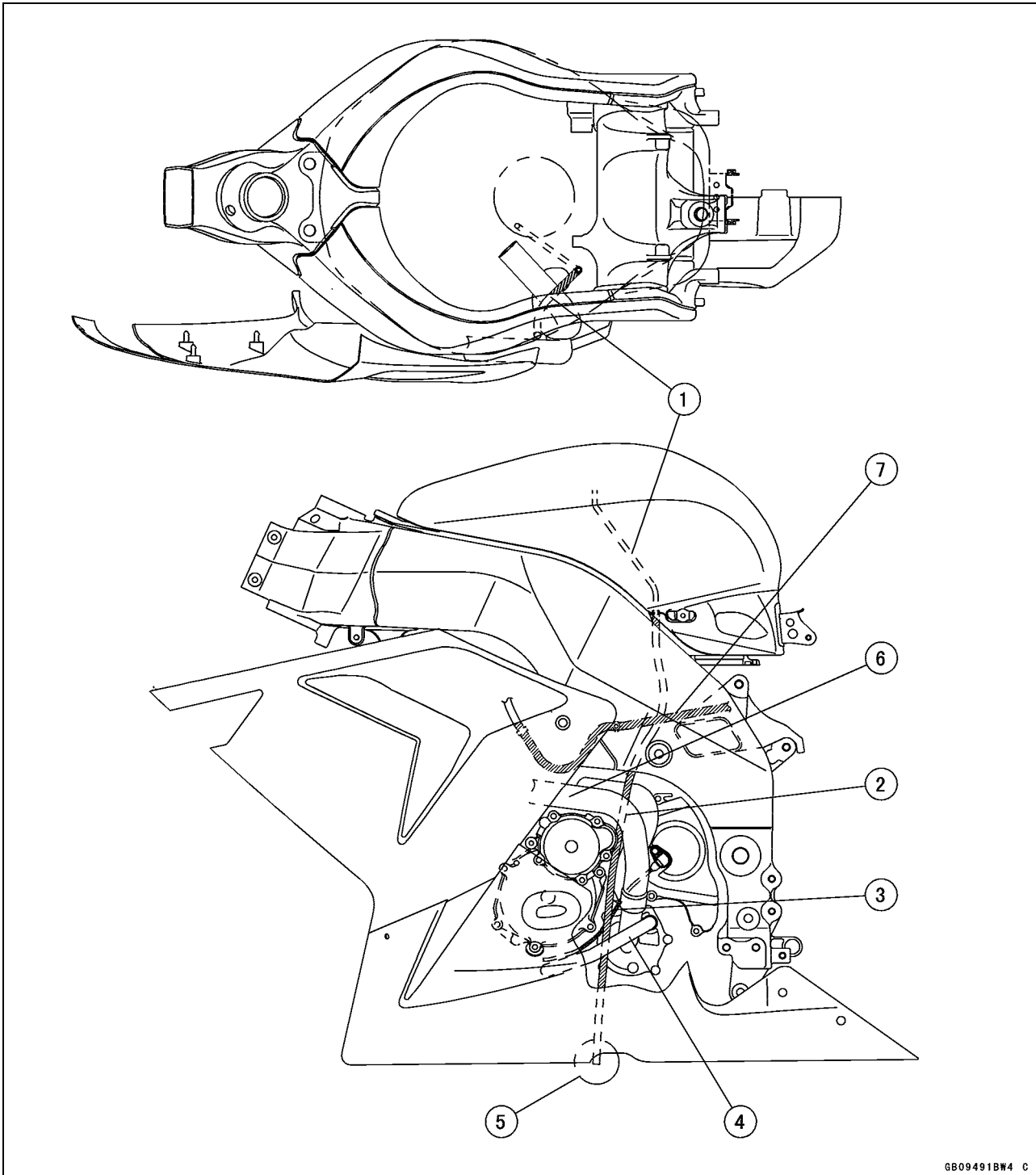

1. Fuel Tank Drain Hose
2. Run the drain hose inside the radiator hose.
3. Speed Sensor Lead
4. Run the drain hose inside the water hose.
5. Put the hose through the cut hole of the under fairing.
6. Radiator Hose
7. Main Harness



Cable, Wire, and Hose Routing

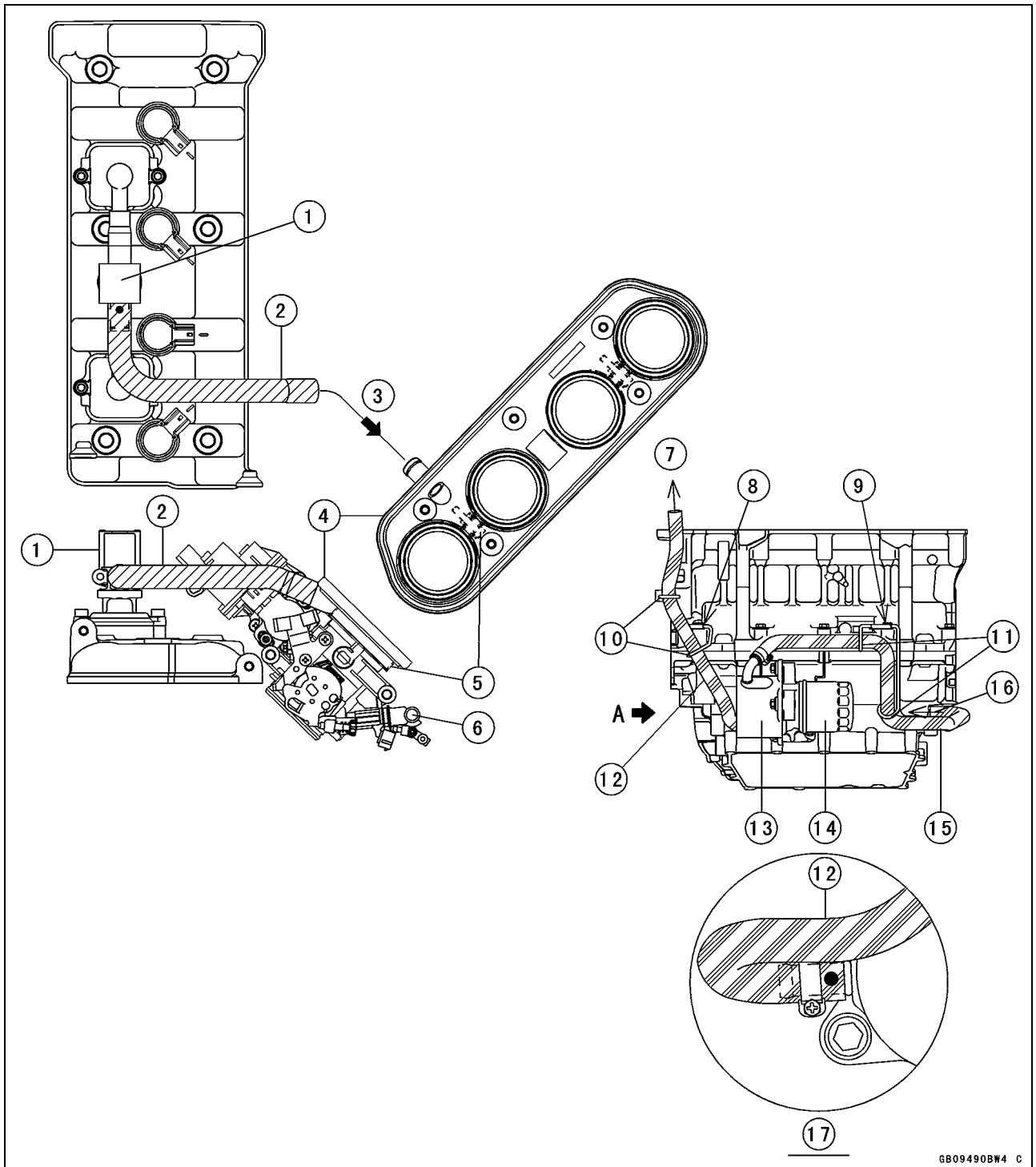

GB09490BW4 C

- |   |  |
|---|--|
| <ul style="list-style-type: none"> <li>1. Air Switching Valve</li> <li>2. Air Switching Valve Hose</li> <li>3. To the fitting of the holder assy.</li> <li>4. Holder Assy</li> <li>5. Clamp</li> <li>6. Throttle Body Assies</li> <li>7. To the Radiator</li> <li>8. Install the upper crankcase bolt with the clamp.</li> <li>9. Install the upper crankcase bolt with the clamp.</li> </ul> | <ul style="list-style-type: none"> <li>10. Run the water hose through the clamp.</li> <li>11. Run the water hose through the clamp.</li> <li>12. Water Hose</li> <li>13. Oil Cooler</li> <li>14. Oil Filter</li> <li>15. Water Hose</li> <li>16. To the Water Pump</li> <li>17. View from A</li> </ul> |
|---|--|

# 17-24 APPENDIX

## Cable, Wire, and Hose Routing

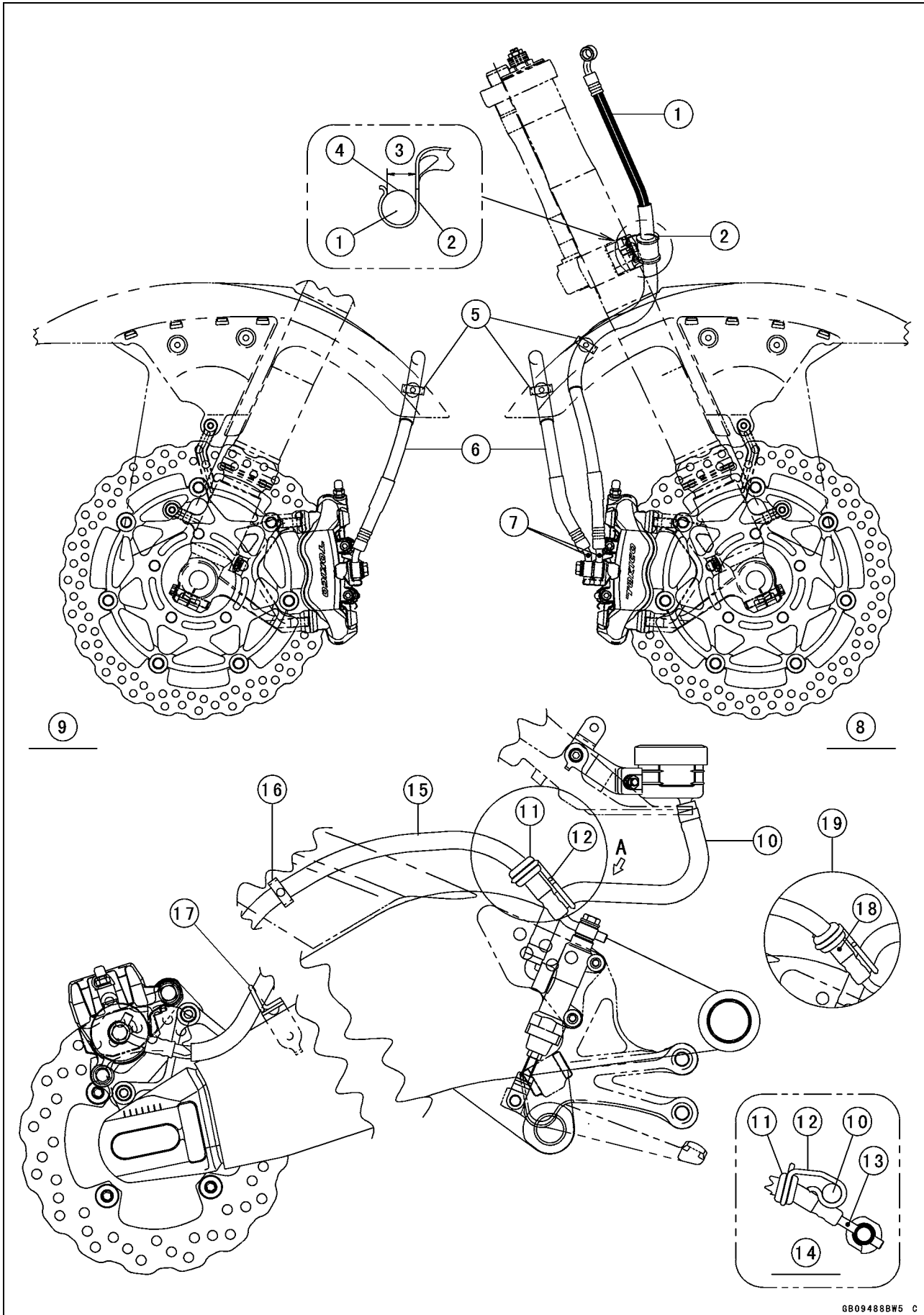

---

**Cable, Wire, and Hose Routing**

---

1. Brake Hose
2. Clamp
3. Install the brake hose so that the mark on it align with the center of opening of the clamp.
4. Mark
5. Clamps
6. Brake Hose
7. Face the paint mark outside.
8. Viewed Right Side
9. Viewed Left Side
10. Brake Hose
11. Rubber Dumper
12. Clamp
13. Face the paint mark outside.
14. Viewed A
15. Brake Hose
16. Clamp
17. Clamp

# 17-26 APPENDIX

## Cable, Wire, and Hose Routing

### California Model

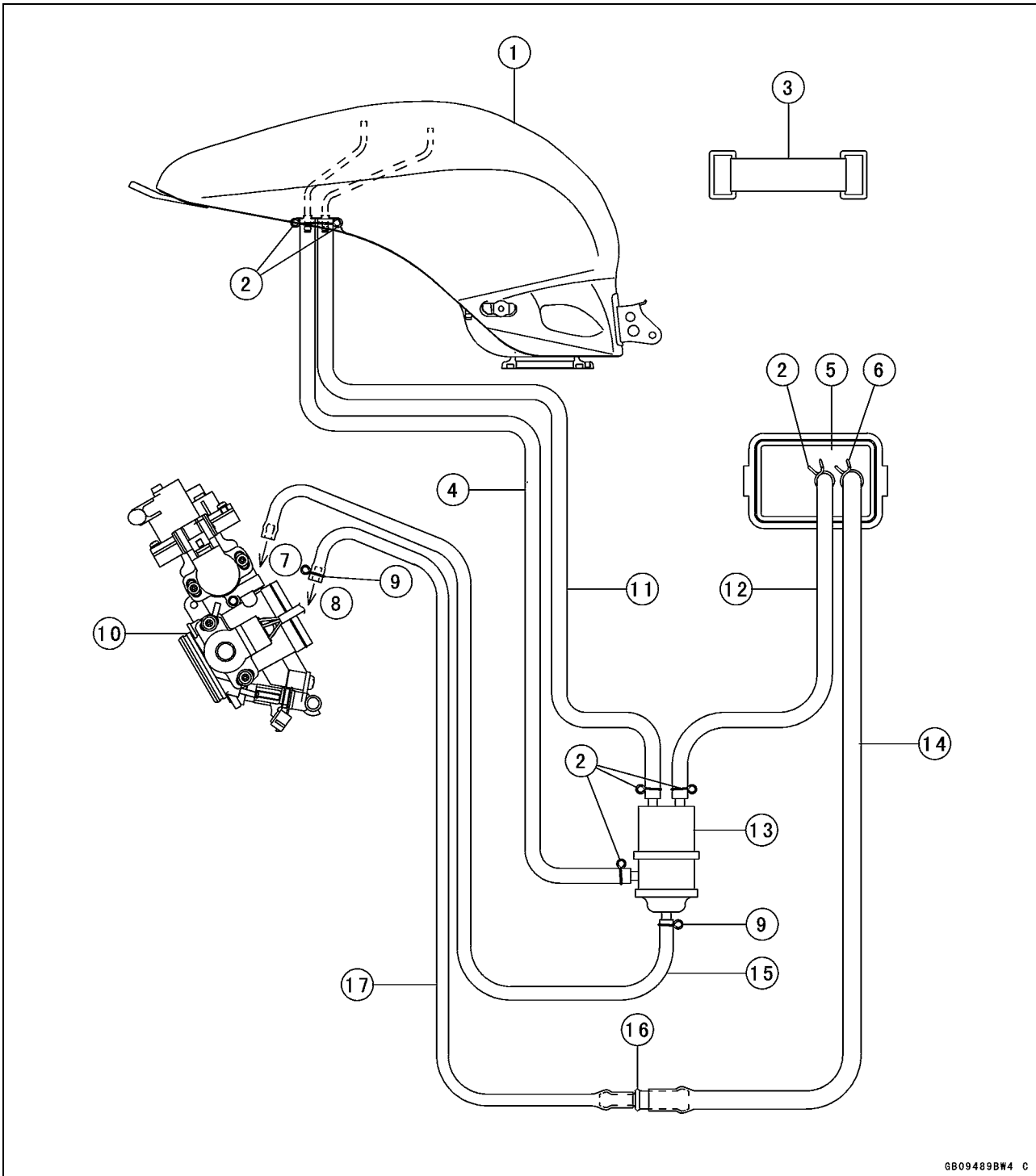

- |   |                     |
|---|---------------------|
| 1. Fuel Tank                              | 10. Throttle Bodies |
| 2. Clamps                                 | 11. Hose (Blue)     |
| 3. Band                                   | 12. Hose (Blue)     |
| 4. Hose (Red)                             | 13. Separator       |
| 5. Canister                               | 14. Hose (Green)    |
| 6. Clamp                                  | 15. Hose (White)    |
| 7. To the Fitting of the Throttle Body #1 | 16. Fitting         |
| 8. To the Fitting of the Throttle Body #2 | 17. Hose (Green)    |
| 9. Clamps                                 |                     |

Cable, Wire, and Hose Routing

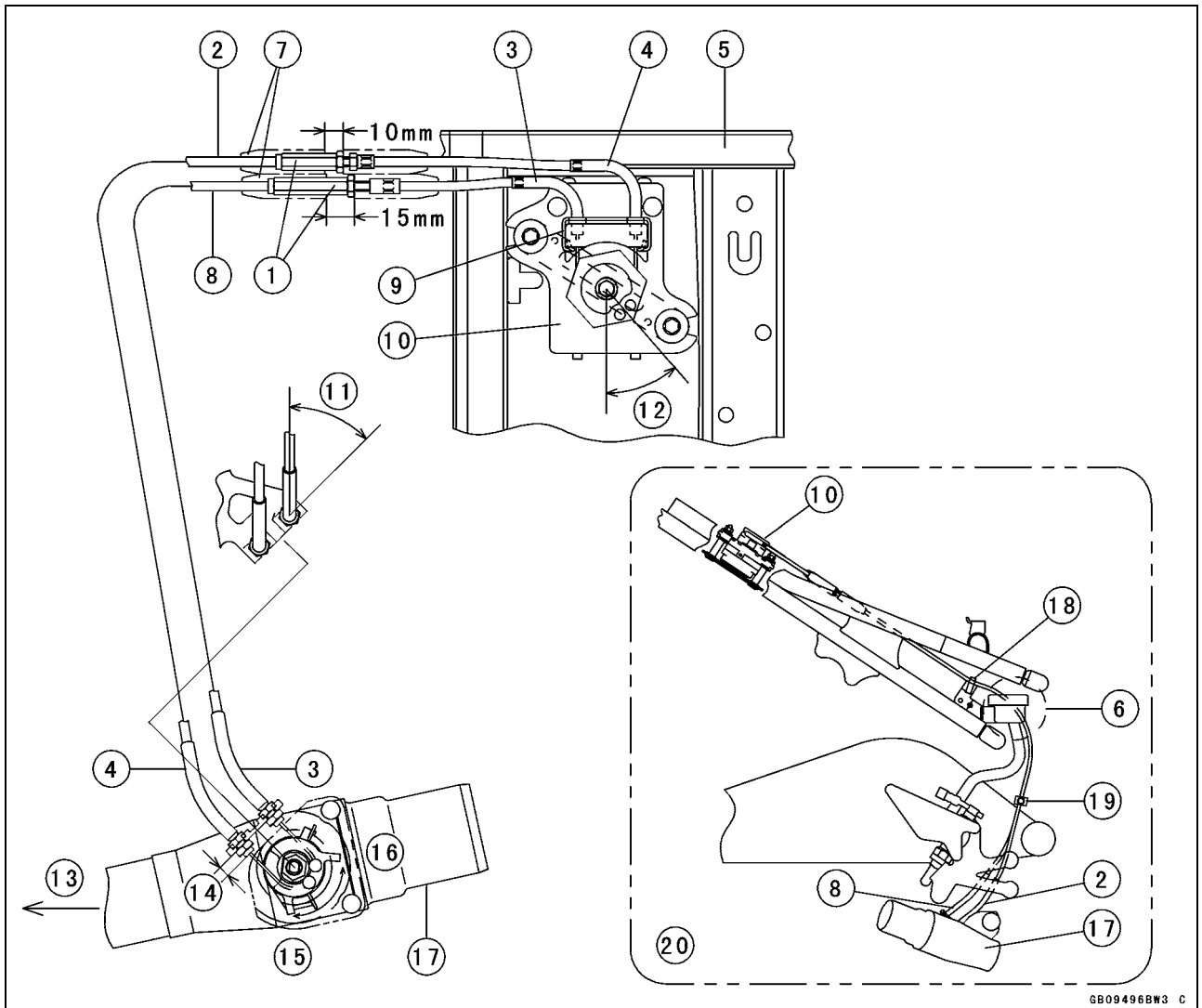

GB09496BW3 C

1. Adjusters
2. Closing Cable
3. Yellow
4. Dark Green
5. Rear Frame
6. Run the cables inside and upper position of the reservoir.
7. Dust Cover
8. Opening Cable
9. Clamp
10. Exhaust Butterfly Valve Actuator
11. About 45°
12. 41.7° ±7° (Original Position of Pulley)
13. Front
14. 6 mm (0.24 in.)
15. Close
16. Open
17. Exhaust Manifold
18. Clamp
19. Clamp
20. Viewed Right Side

## 17-28 APPENDIX

### Troubleshooting Guide

---

#### NOTE

- Refer to the *Fuel System* chapter for most of DFI trouble shooting guide.
- This is not an exhaustive list, giving every possible cause for each problem listed. It is meant simply as a rough guide to assist the troubleshooting for some of the more common difficulties.

#### Engine Doesn't Start, Starting Difficulty:

##### Starter motor not rotating:

- Starter lockout switch or neutral switch trouble
- Starter motor trouble
- Battery voltage low
- Starter relay not contacting or operating
- Starter button not contacting
- Wiring open or shorted
- Ignition switch trouble
- Engine stop switch trouble
- Fuse blown

##### Starter motor rotating but engine doesn't turn over:

- Immobilizer system trouble
- Starter clutch trouble
- Vehicle-down-sensor (DFI) coming off

##### Engine won't turn over:

- Valve seizure
- Valve lifter seizure
- Cylinder, piston seizure
- Crankshaft seizure
- Connecting rod small end seizure
- Connecting rod big end seizure
- Transmission gear or bearing seizure
- Camshaft seizure
- Starter idle gear seizure

##### No fuel flow:

- No fuel in tank
- Fuel pump trouble
- Fuel tank air vent obstructed
- Fuel filter clogged
- Fuel line clogged

##### Engine flooded:

- Clean spark plug and adjust plug gap
- Starting technique faulty  
(When flooded, do not crank the engine with the throttle fully opened. This promotes engine flood because more fuel is supplied automatically by DFI.)

##### No spark; spark weak:

- Vehicle-down-sensor (DFI) coming off
- Ignition switch not ON
- Engine stop switch turned OFF
- Clutch lever not pulled in or gear not in neutral
- Battery voltage low

- Immobilizer system trouble
- Spark plug dirty, broken, or gap maladjusted
- Stick coil shorted or not in good contact
- Stick coil trouble
- Spark plug incorrect
- IC igniter in ECU trouble
- Camshaft position sensor trouble
- Neutral, starter lockout, or side stand switch trouble
- Crankshaft sensor trouble
- Ignition switch or engine stop switch shorted
- Wiring shorted or open
- Fuse blown

##### Fuel/air mixture incorrect:

- Bypass screw and/or idle adjusting screw maladjusted
- Air passage clogged
- Air cleaner clogged, poorly sealed, or missing

##### Compression Low:

- Spark plug loose
- Cylinder head not sufficiently tightened down
- No valve clearance
- Cylinder, piston worn
- Piston ring bad (worn, weak, broken, or sticking)
- Piston ring/groove clearance excessive
- Cylinder head gasket damaged
- Cylinder head warped
- Valve spring broken or weak
- Valve not seating properly (valve bent, worn, or carbon accumulation on the seating surface)

#### Poor Running at Low Speed:

##### Spark weak:

- Battery voltage low
- Spark plug dirty, broken, or maladjusted
- Stick coil wiring trouble
- Stick coil not in good contact
- Spark plug incorrect
- IC igniter in ECU trouble
- Camshaft position sensor trouble
- Crankshaft sensor trouble
- Stick coil trouble
- Immobilizer system trouble

##### Fuel/air mixture incorrect:

- Bypass screw maladjusted
- Air passage clogged
- Air bleed pipe bleed holes clogged
- Pilot passage clogged
- Air cleaner clogged, poorly sealed, or missing
- Fuel tank air vent obstructed

## Troubleshooting Guide

Fuel pump trouble  
Throttle body assy holder loose  
Air cleaner duct loose

### **Compression low:**

Spark plug loose  
Cylinder head not sufficiently tightened down  
No valve clearance  
Cylinder, piston worn  
Piston ring bad (worn, weak, broken, or sticking)  
Piston ring/groove clearance excessive  
Cylinder head warped  
Cylinder head gasket damaged  
Valve spring broken or weak  
Valve not seating properly (valve bent, worn, or carbon accumulation on the seating surface)

### **Other:**

IC igniter in ECU trouble  
Throttle body assy not synchronizing  
Engine oil viscosity too high  
Drive train trouble  
Brake dragging  
Air suction valve trouble  
Air switching valve trouble  
Engine overheating  
Clutch slipping

## **Poor Running or No Power at High Speed:**

### **Firing incorrect:**

Spark plug dirty, broken, or maladjusted  
Stick coil wiring trouble  
Stick coil not in good contact  
Spark plug incorrect  
Camshaft position sensor trouble  
IC igniter in ECU trouble  
Crankshaft sensor trouble  
Stick coil trouble

### **Fuel/air mixture incorrect:**

Air cleaner clogged, poorly sealed, or missing  
Air cleaner O-ring damaged  
Air cleaner duct loose  
Water or foreign matter in fuel  
Throttle body assy holder loose  
Fuel to injector insufficient (DFI)  
Fuel tank air vent obstructed  
Fuel line clogged  
Fuel pump trouble (DFI)

### **Compression low:**

Spark plug loose  
Cylinder head not sufficiently tightened down  
No valve clearance  
Cylinder, piston worn

Piston ring bad (worn, weak, broken, or sticking)  
Piston ring/groove clearance excessive  
Cylinder head gasket damaged  
Cylinder head warped  
Valve spring broken or weak  
Valve not seating properly (valve bent, worn, or carbon accumulation on the seating surface.)

### **Knocking:**

Carbon built up in combustion chamber  
Fuel poor quality or incorrect  
Spark plug incorrect  
IC igniter in ECU trouble  
Camshaft position sensor trouble  
Crankshaft sensor trouble

### **Miscellaneous:**

Throttle valve won't fully open  
Brake dragging  
Clutch slipping  
Engine overheating  
Engine oil level too high  
Engine oil viscosity too high  
Drive train trouble  
Air suction valve trouble  
Air switching valve trouble  
Catalytic converter melt down due to muffler overheating (KLEEN)

## **Overheating:**

### **Firing incorrect:**

Spark plug dirty, broken, or maladjusted  
Spark plug incorrect  
IC igniter in ECU trouble

### **Muffler overheating:**

For KLEEN, do not run the engine even if with only one cylinder misfiring or poor running (Request the nearest service facility to correct it)

For KLEEN, do not push-start with a dead battery (Connect another full-charged battery with jumper cables, and start the engine using the electric starter)

For KLEEN, do not start the engine under misfire due to spark plug fouling or poor connection of the stick coil

For KLEEN, do not coast the motorcycle with the ignition switch off (Turn the ignition switch ON and run the engine)

IC igniter in ECU trouble

### **Fuel/air mixture incorrect:**

Throttle body assy holder loose  
Air cleaner duct loose  
Air cleaner poorly sealed, or missing  
Air cleaner O-ring damaged  
Air cleaner clogged

## 17-30 APPENDIX

### Troubleshooting Guide

---

#### **Compression high:**

Carbon built up in combustion chamber

#### **Engine load faulty:**

Clutch slipping  
Engine oil level too high  
Engine oil viscosity too high  
Drive train trouble  
Brake dragging

#### **Lubrication inadequate:**

Engine oil level too low  
Engine oil poor quality or incorrect

#### **Oil cooler incorrect:**

Oil cooler clogged

#### **Gauge incorrect:**

Water temperature gauge broken  
Water temperature sensor broken

#### **Coolant incorrect:**

Coolant level too low  
Coolant deteriorated  
Wrong coolant mixed ratio

#### **Cooling system component incorrect:**

Radiator fin damaged  
Radiator clogged  
Thermostat trouble  
Radiator cap trouble  
Radiator fan switch trouble  
Radiator fan relay trouble  
Fan motor broken  
Fan blade damaged  
Water pump not turning  
Water pump impeller damaged

#### **Over Cooling:**

##### **Gauge incorrect:**

Water temperature gauge broken  
Water temperature sensor broken

##### **Cooling system component incorrect:**

Radiator fan switch trouble  
Thermostat trouble

#### **Clutch Operation Faulty:**

##### **Clutch slipping:**

Friction plate worn or warped  
Steel plate worn or warped  
Clutch spring broken or weak  
Clutch hub or housing unevenly worn  
No clutch lever play  
Clutch inner cable trouble  
Clutch release mechanism trouble

##### **Clutch not disengaging properly:**

Clutch plate warped or too rough  
Clutch spring compression uneven  
Engine oil deteriorated  
Engine oil viscosity too high  
Engine oil level too high  
Clutch housing frozen on drive shaft  
Clutch hub nut loose

Clutch hub spline damaged  
Clutch friction plate installed wrong  
Clutch lever play excessive  
Clutch release mechanism trouble

#### **Gear Shifting Faulty:**

##### **Doesn't go into gear; shift pedal doesn't return:**

Clutch not disengaging  
Shift fork bent or seized  
Gear stuck on the shaft  
Gear positioning lever binding  
Shift return spring weak or broken  
Shift return spring pin loose  
Shift mechanism arm spring broken  
Shift mechanism arm broken  
Shift pawl broken

##### **Jumps out of gear:**

Shift fork ear worn, bent  
Gear groove worn  
Gear dogs and/or dog holes worn  
Shift drum groove worn  
Gear positioning lever spring weak or broken  
Shift fork guide pin worn  
Drive shaft, output shaft, and/or gear splines worn

##### **Overshifts:**

Gear positioning lever spring weak or broken  
Shift mechanism arm spring broken

#### **Abnormal Engine Noise:**

##### **Knocking:**

IC igniter in ECU trouble  
Carbon built up in combustion chamber  
Fuel poor quality or incorrect  
Spark plug incorrect  
Overheating

##### **Piston slap:**

Cylinder/piston clearance excessive  
Cylinder, piston worn  
Connecting rod bent  
Piston pin, piston pin hole worn

##### **Valve noise:**

Valve clearance incorrect  
Valve spring broken or weak  
Camshaft bearing worn  
Valve lifter worn

##### **Other noise:**

Connecting rod small end clearance excessive  
Connecting rod big end clearance excessive  
Piston ring/groove clearance excessive  
Piston ring worn, broken, or stuck  
Piston ring groove worn



## Troubleshooting Guide

Piston seizure, damage  
 Cylinder head gasket leaking  
 Exhaust pipe leaking at cylinder head connection  
 Crankshaft runout excessive  
 Engine mount loose  
 Crankshaft bearing worn  
 Primary gear worn or chipped  
 Camshaft chain tensioner trouble  
 Camshaft chain, sprocket, guide worn  
 Air suction valve damaged  
 Air switching valve damaged  
 Alternator rotor loose  
 Catalytic converter melt down due to muffler overheating (KLEEN)

### Abnormal Drive Train Noise:

#### Clutch noise:

Clutch damper weak or damaged  
 Clutch housing/friction plate clearance excessive  
 Clutch housing gear worn  
 Wrong installation of outside friction plate

#### Transmission noise:

Bearings worn  
 Transmission gear worn or chipped  
 Metal chips jammed in gear teeth  
 Engine oil insufficient

#### Drive line noise:

Drive chain adjusted improperly  
 Drive chain worn  
 Rear and/or engine sprocket worn  
 Chain lubrication insufficient  
 Rear wheel misaligned

### Abnormal Frame Noise:

#### Front fork noise:

Oil insufficient or too thin  
 Spring weak or broken

#### Rear shock absorber noise:

Shock absorber damaged

#### Disc brake noise:

Pad installed incorrectly  
 Pad surface glazed  
 Disc warped  
 Caliper trouble

#### Other noise:

Bracket, nut, bolt, etc. not properly mounted or tightened

### Oil Pressure Warning Light Goes On:

Engine oil pump damaged  
 Engine oil screen clogged  
 Engine oil filter clogged  
 Engine oil level too low  
 Engine oil viscosity too low

Camshaft bearing worn  
 Crankshaft bearing worn  
 Oil pressure switch damaged  
 Wiring faulty  
 Relief valve stuck open  
 O-ring at the oil passage in the crankcase damaged

### Exhaust Smokes Excessively:

#### White smoke:

Piston oil ring worn  
 Cylinder worn  
 Valve oil seal damaged  
 Valve guide worn  
 Engine oil level too high

#### Black smoke:

Air cleaner clogged

#### Brown smoke:

Air cleaner duct loose  
 Air cleaner O-ring damaged  
 Air cleaner poorly sealed or missing

### Handling and/or Stability

#### Unsatisfactory:

##### Handlebar hard to turn:

Cable routing incorrect  
 Hose routing incorrect  
 Wiring routing incorrect  
 Steering stem nut too tight  
 Steering stem bearing damaged  
 Steering stem bearing lubrication inadequate  
 Steering stem bent  
 Tire air pressure too low

##### Handlebar shakes or excessively vibrates:

Tire worn  
 Swingarm pivot bearing worn  
 Rim warped, or not balanced  
 Wheel bearing worn  
 Handlebar clamp bolt loose  
 Steering stem nut loose  
 Front, rear axle runout excessive  
 Engine mounting bolt loose

##### Handlebar pulls to one side:

Frame bent  
 Wheel misalignment  
 Swingarm bent or twisted  
 Swingarm pivot shaft runout excessive  
 Steering maladjusted  
 Front fork bent  
 Right and left front fork oil level uneven

##### Shock absorption unsatisfactory:

(Too hard)  
 Front fork oil excessive  
 Front fork oil viscosity too high  
 Rear shock absorber adjustment too hard  
 Tire air pressure too high

## 17-32 APPENDIX

### Troubleshooting Guide

---

- Front fork bent  
(Too soft)
- Tire air pressure too low
- Front fork oil insufficient and/or leaking
- Front fork oil viscosity too low
- Rear shock adjustment too soft
- Front fork, rear shock absorber spring weak
- Rear shock absorber oil leaking

#### **Brake Doesn't Hold:**

- Air in the brake line
- Pad or disc worn
- Brake fluid leakage
- Disc warped
- Contaminated pad
- Brake fluid deteriorated
- Primary or secondary cup damaged in master cylinder
- Master cylinder scratched inside

#### **Battery Trouble:**

##### **Battery discharged:**

- Charge insufficient
- Battery faulty (too low terminal voltage)
- Battery lead making poor contact
- Load excessive (e.g., bulb of excessive wattage)
- Ignition switch trouble
- Alternator trouble
- Wiring faulty
- Regulator/rectifier trouble

##### **Battery overcharged:**

- Alternator trouble
- Regulator/rectifier trouble
- Battery faulty

## MODEL APPLICATION

Year	Model	Beginning Frame No.
2004	ZX1000-C1	JKAZXCC1□4A000001 or JKAZXT00CCA000001 or ZXT00C-000001
2005	ZX1000-C2	JKAZXCC1□5A020001 or JKAZXT00CCA020001 or ZXT00C-020001

□:This digit in the frame number changes from one machine to another.



KAWASAKI HEAVY INDUSTRIES, LTD.  
Consumer Products & Machinery Company

Part No.99924-1322-02

Printed in Japan