



RIPMO

VERSION 3

RIPLY

VERSION 5

IBIS CYCLES
SANTA CRUZ, CA

RIPMO

BUILT TO RIP

The Ripmo isn't just a bike; it's a legend.

With multiple "Best in Test" awards and years of high level competition at the notoriously brutal Enduro World Series, it's the ultimate trail-slaying machine. How do you improve on that?

The Ripmo is loaded with new features: internal downtube storage, a flip chip for mixed wheels, a slacker head angle, and increased coil compatibility. We've also expanded our sizing options and added size-specific details—right down to the bottom bracket height.



160_{MM}
FRONT TRAVEL

150_{MM}
REAR TRAVEL





ADVENTURE AWAITS

Meet the Ripley, your new best friend for every trail adventure. The award-winning bike has been updated with more travel and slacker geometry, making it even more capable and fun. It rivals the efficiency of an e-bike uphill, while offering snappy, playful performance with 130mm of ultra-efficient dw-link travel. Need to stash your snacks? The Ripley now features internal frame storage for all your stuff. Plus, with expanded size ranges, everyone gets the perfect fit. Whether you're popping wheelies or conquering climbs, the Ripley is game.



140_{MM}
FRONT TRAVEL

130_{MM}
REAR TRAVEL





KEY FACTS

FOR BOTH BIKES





KEY FACTS

SIZE SPECIFIC EVERYTHING

Every rider deserves the same great ride feel, no matter their height or proportions. We use size specific seat tube angles and suspension kinematics to bring incredible balance and speed to all size riders. Even chainstay length and bottom bracket height are tailored to each frame size.

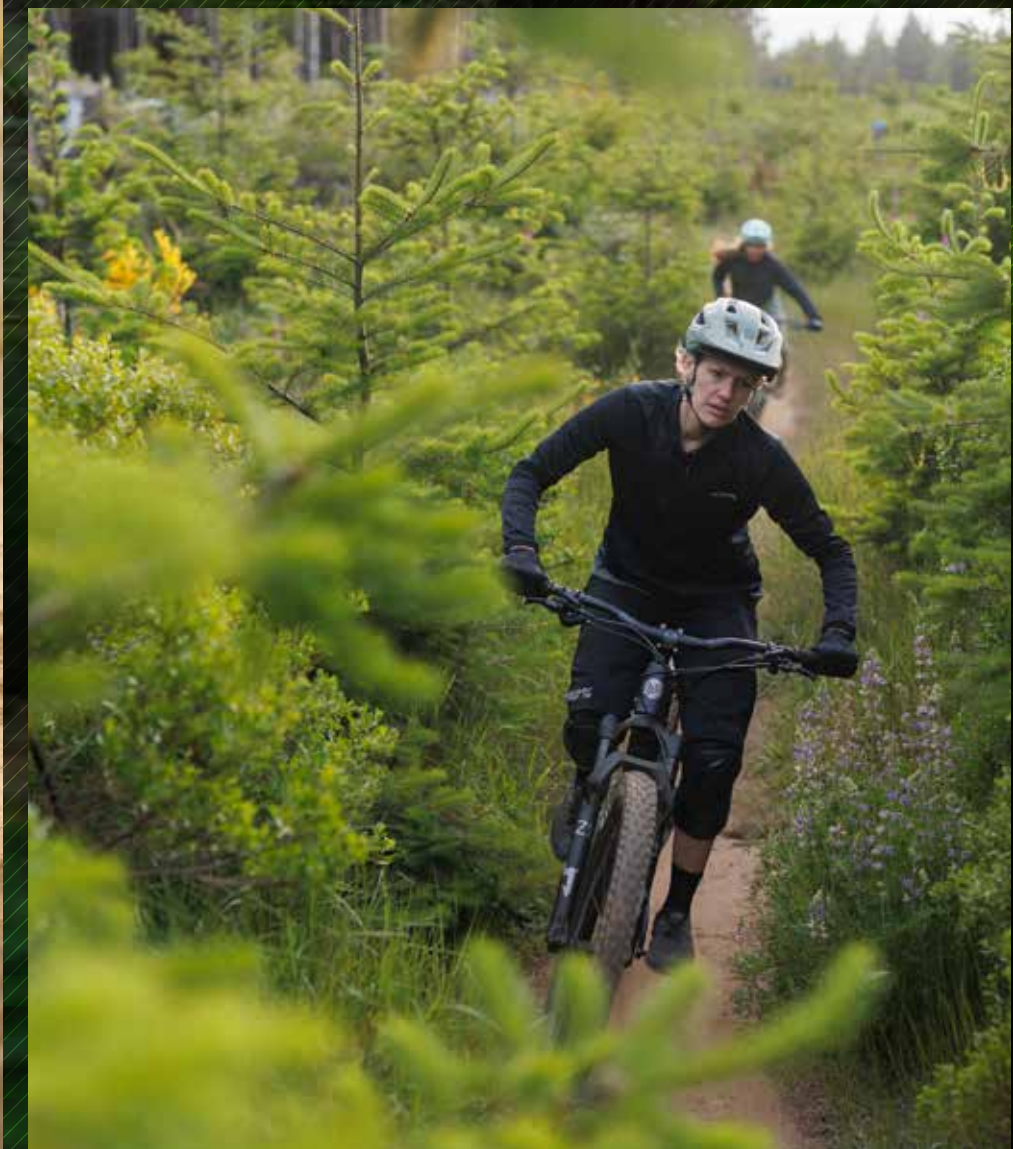

KEY FACTS

5 SIZES

We've added a third size in the middle of the bell curve to provide a fit that's just right. With 80% of our riders falling between 5'5" and 6'0," we introduced a new "Extra-Medium" size. The extra-medium (size 3) now sits in the middle of our size range, while our size five remains the traditional XL.

RIPLEY/RIPMO DEVELOPMENT
SKETCHES BY ROXY LO

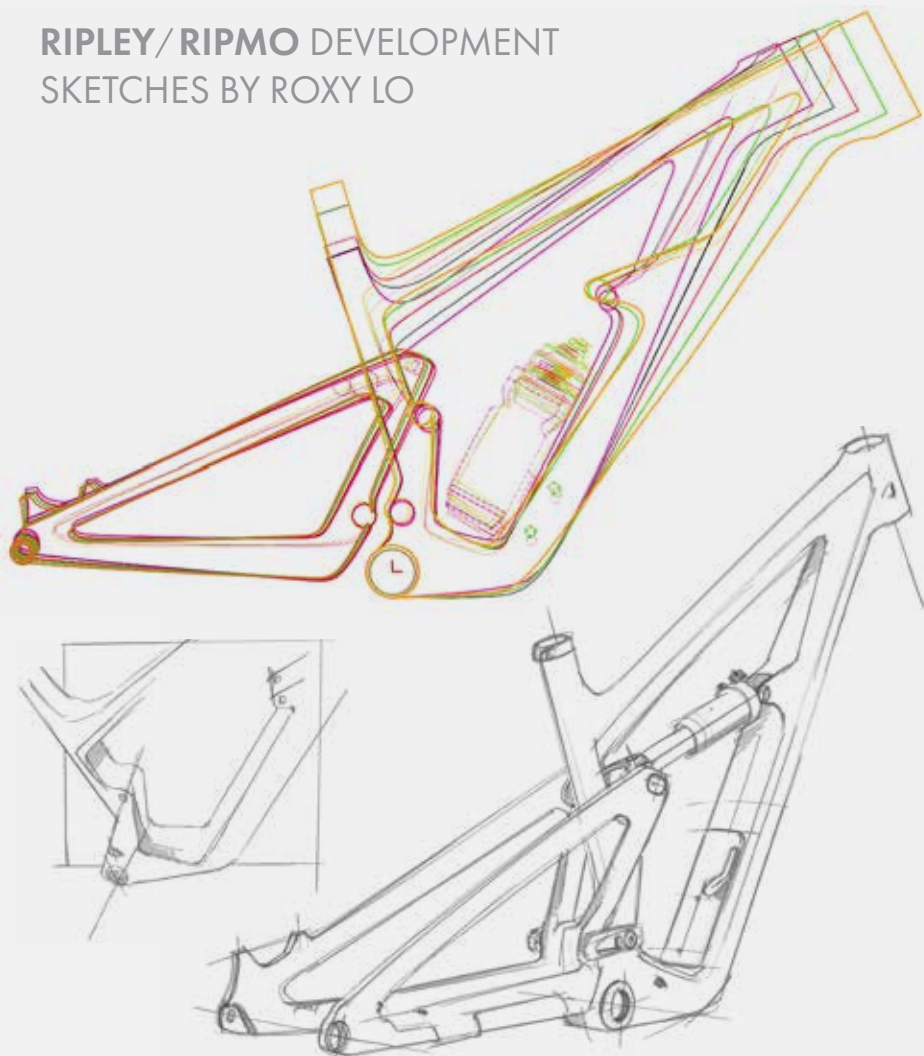

5 SIZES

SM, MD, XM, LG, XL





29"

RIPLEY: ALL SIZES
RIPMO: SIZES XM - XL

MX

RIPLEY: VIA FLIP-CHIP
RIPMO: SIZES SM-MD

 **KEY FACTS**

FLIP IT

We've added more adjustability with a new flip chip - now you can run 29" or 27.5"/29" mixed (MX) wheels on all sizes without compromising the geometry.

On the Ripmo, the Extra Medium and larger sizes ship with 29" wheels, while the Small and Medium sizes come with MX wheels.





KEY FACTS



dw-link

SUSPENSION



DW-LINK

We continue to use the critically acclaimed dw-link suspension platform known for its efficient climbing and superlative downhill performance; it sets the standard for modern mountain bikes.

Our size-specific kinematics make sure every size bike pedals amazing while still keeping things quiet and calm on challenging trails.



COIL

COMPATIBLE ON
ALL FRAME SIZES

Drawing on the race-proven HD6 design, the Ripmo now has a coil spring friendly progressive shock rate and shorter clevis which makes it compatible with pretty much any coil shock. Our size-specific kinematics make sure every size bike pedals amazing while still keeping things quiet and calm on challenging trails.



 **KEY FACTS**

INTERNAL FRAME STORAGE
Get that gear off your back and into your bike with our frame storage system. The latch operates effortlessly, even in cold, muddy conditions while wearing gloves. The door is water-resistant, rattle-free, and robust.

We've partnered with Cotopaxi to craft a set of two internal bags for your snacks, tools or whatever. Cotopaxi is known for high-quality construction and sustainable practices; each bag is crafted from remnants and dead stock, making them colorful and unique.

The result of our obsession - every detail on the Ripmo has been thought through, refined and refined again.



 **DETAILS**

34.9MM
SEATPOST

FULLY TUBED INTERNAL
CABLE ROUTING

CHAINSTAY
PROTECTION

27.5 / 29
ADJUSTABLE FLIP CHIP

180MM POST MOUNT
DISC BRAKE TABS

INTERNAL FRAME STORAGE
w/IBIS x COTOPAXI COLLAB BAGS

SRAM UDH
148x12MM REAR AXLE

THREADED
BOTTOM BRACKET



RIPMO GEOMETRY

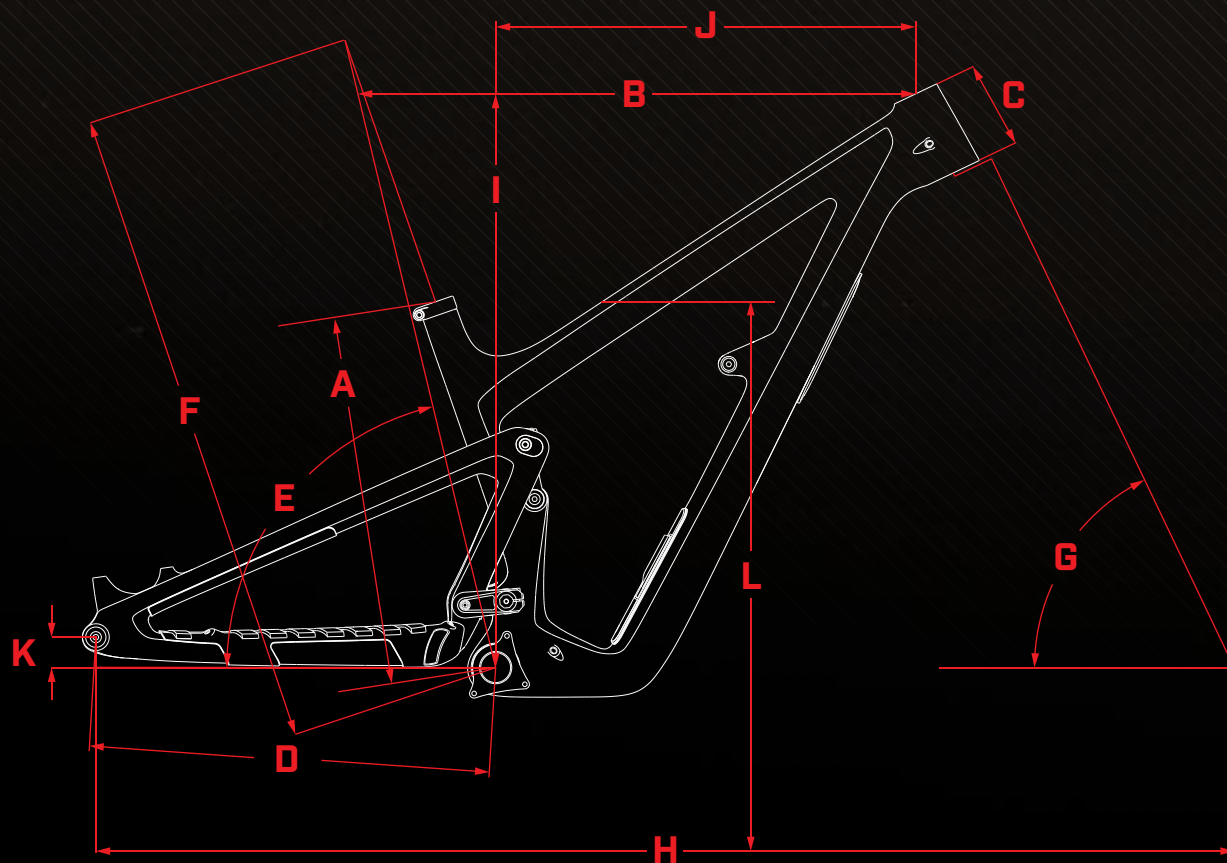

160MM FORK (575MM AXLE TO CROWN)

SIZE		SMALL	MEDIUM	EXTRA MEDIUM	LARGE	X-LARGE
SEAT TUBE MM	A	395	400	415	457	477
TOP TUBE MM	B	578	605	630	655	685
HEAD TUBE MM	C	85	95	110	125	140
CHAINSTAY MM	D	435		436	438	440
SEAT TUBE ANGLE	E	77°	76.5°		77°	77.5°
SADDLE HEIGHT FOR SEAT TUBE ANGLE MM	F	650	700	745	790	830
HEAD TUBE ANGLE	G	64.5°				
WHEELBASE MM	H	1195	1219	1249	1286	1329
STACK MM	I	616	622	633	643	654
REACH MM	J	436	456	478	506	540
BB DROP MM	K	36	33	30	27	24
BB HEIGHT* MM		338	341	344	349	350
STANDOVER MM	L	693	734	757	772	784
RECOMMENDED SEATPOST DROP MM		140	170	185	213	
CRANK LENGTH MM		165		170		
TIRE SIZE IN		2.35-2.5				
WATER BOTTLE SIZE		1 x 22oz		1 x 26oz		

*With Maxxis 29x2.4 WT tires = 748mm diameter, 27.5x2.5 WT rear tires = 708mm diameter.



RIPMO BUILD KITS

FRAME ONLY \$3,699					
FORK	Marzocchi Bomber Z1, 160mm, 29", 110mm x 15mm	Marzocchi Bomber Z1, 160mm, 29", 110mm x 15mm	Fox Float 36, Factory Series, GripX, 160mm, 29", 110mm x 15mm	Fox Float 36, Factory Series, GripX, 160mm, 29", 110mm x 15mm	Fox Float 36, Factory Series, GripX, 160mm, 29", 10mm x 15mm
SHOCK	Fox Float X, Factory Series, 2-Pos Adj. w/EVOL, 230mm x 60mm	Fox Float X, Factory Series, 2-Pos Adj. w/EVOL, 230mm x 60mm	Fox Float X, Factory Series, 2-Pos Adj. w/EVOL, 230mm x 60mm	Fox Float X, Factory Series, 2-Pos Adj. w/EVOL, 230mm x 60mm	Fox Float X, Factory Series, 2-Pos Adj. w/EVOL, 230mm x 60mm
RIMS (F/R)	Blackbird Send Alloy, 32 Hole, S-M, F: Send I 29" R: Send II 27.5" XM-XL, F: Send I 29" R: Send II 29"	Blackbird Send Alloy, 32 Hole, S-M, F: Send I 29" R: Send II 27.5" XM-XL, F: Send I 29" R: Send II 29"	Blackbird Send Alloy, 32 Hole, S-M, F: Send I 29" R: Send II 27.5" XM-XL, F: Send I 29" R: Send II 29"	Blackbird Send Alloy, 32 Hole, S-M, F: Send I 29" R: Send II 27.5" XM-XL, F: Send I 29" R: Send II 29"	Blackbird Send Alloy, 32 Hole, S-M, F: Send I 29" R: Send II 27.5" XM-XL, F: Send I 29" R: Send II 29"
HUBS (F/R)	Ibis Logo, 32H, 6-Bolt, F/R: Boost	Ibis Logo, 32H, 6-Bolt, F/R: Boost	Ibis Logo, 32H, 6-Bolt, F/R: Boost	Ibis Logo, 32H, 6-Bolt, F/R: Boost	Ibis Logo, 32H, 6-Bolt, F/R: Boost
SPOKES/NIPPLES	Sapim, Dlight Double Butted, 14g Alloy	Sapim, Dlight Double Butted, 14g Alloy	Sapim, Dlight Double Butted, 14g Alloy	Sapim, Dlight Double Butted, 14g Alloy	Sapim, Dlight Double Butted, 14g Alloy
FRONT TIRE	Maxxis DHF, 29" x 2.5", Exo+	Maxxis DHF, 29" x 2.5", Exo+	Maxxis DHF, 29" x 2.5", Exo+	Maxxis DHF, 29" x 2.5", Exo+	Maxxis DHF, 29" x 2.5", Exo+
REAR TIRE	S-M: Maxxis DHR2, 27.5" x 2.5", Exo+ XM-XL: Maxxis DHR2, 29" x 2.5", Exo+	S-M: Maxxis DHR2, 27.5" x 2.5", Exo+ XM-XL: Maxxis DHR2, 29" x 2.5", Exo+	S-M: Maxxis DHR2, 27.5" x 2.5", Exo+ XM-XL: Maxxis DHR2, 29" x 2.5", Exo+	S-M: Maxxis DHR2, 27.5" x 2.5", Exo+ XM-XL: Maxxis DHR2, 29" x 2.5", Exo+	S-M: Maxxis DHR2, 27.5" x 2.5", Exo+ XM-XL: Maxxis DHR2, 29" x 2.5", Exo+
BRAKES	Shimano Deore, M6120, 4-Piston	Shimano XT, M8120, 4-Piston	Shimano XT, M8120, 4-Piston	SRAM Code RSC, 4-Piston	SRAM Code RSC, 4-Piston
ROTOR (F/R)	Shimano SM-RT66, F: 203mm, R: 180mm	Shimano SM-RT66, F: 203mm, R: 180mm	Shimano SM-RT86, F: 203mm, R: 180mm	SRAM Centerline, F: 200mm, R: 180mm	SRAM Centerline, F: 200mm, R: 180mm
CRANKSET	Shimano Deore, M6120, 24mm Spindle, S-M: 165mm, XM-XL: 170mm	Shimano SLX, M7120, 24mm Spindle, S-M: 165mm, XM-XL: 170mm	Shimano XT, M8120, 24mm Spindle, 30T Alloy Ring, S-M: 165mm, XM-XL: 170mm	SRAM GX, Eagle Transmission, DUB, SM-MD: 165mm, XM-XL: 170mm	SRAM XO, Eagle Transmission, DUB, SM-MD: 165mm, XM-XL: 170mm
BOTTOM BRACKET	Shimano, SM-BB52	Shimano, SM-BB52	Shimano XT MT800	SRAM DUB BSA	SRAM DUB BSA
REAR DERAILLEUR	Shimano Deore, M6100, Shadow Plus	Shimano SLX, M7100, Shadow Plus	Shimano XT, M8100, Shadow Plus	SRAM GX, Eagle Transmission	SRAM XO, Eagle Transmission
SHIFTER	Shimano Deore, M6100	Shimano SLX, M7100	Shimano XT, M8100	SRAM GX, Eagle Transmission	SRAM XO, Eagle Transmission
CASSETTE	Shimano Deore, M6100, 10-51T	Shimano SLX, M7100, 10-51T	Shimano XT, M8100, 10-51T	SRAM GX, Eagle Transmission, 10-52T	SRAM XO, Eagle Transmission, 10-52T
CHAIN	Shimano Deore, M6100	Shimano SLX, M7100	Shimano XT M8100	SRAM GX, Eagle Transmission	SRAM XO, Eagle Transmission
HEADSET	Cane Creek 40: ZS44/ZS56	Cane Creek 40: ZS44/ZS56	Cane Creek 40: ZS44/ZS56	Cane Creek 40: ZS44/ZS56	Cane Creek 40: ZS44/ZS56
GRIPS	Lizard Skin Charger Evo	Lizard Skin Charger Evo	Lizard Skin Charger Evo	Lizard Skin Charger Evo	Lizard Skin Charger Evo
HANDLEBAR	Ibis HiFi, 31.8mm, 800mm	Ibis HiFi, 31.8mm, 800mm	Blackbird HiFi, 35mm, 800mm	Blackbird HiFi, 35mm, 800mm	Blackbird HiFi, 35mm, 800mm
STEM	Ibis, 31.8mm, S-M: 40mm, XM-XL: 50mm	Ibis, 31.8mm, S-M: 40mm, XM-XL: 50mm	Blackbird, 35mm, S-M: 35mm, XM-XL: 50mm	Blackbird, 35mm, S-M: 35mm, XM-XL: 50mm	Blackbird, 35mm, S-M: 35mm, XM-XL: 50mm
SEATPOST	KS i-Rage Dropper, 34.9mm, S: 125mm, M: 150mm, XM: 170mm, L-XL: 190	Bike Yoke Revive Dropper, 34.9mm, S: 125mm, M: 160mm, XM: 185mm, L-XL: 213mm	Bike Yoke Revive Dropper, 34.9mm, S: 125mm, M: 160mm, XM: 185mm, L-XL: 213mm	Bike Yoke Revive Dropper, 34.9mm, S: 125mm, M: 160mm, XM: 185mm, L-XL: 213mm	Bike Yoke Revive Dropper, 34.9mm, S: 125mm, M: 160mm, XM: 185mm, L-XL: 213mm
SADDLE	WTB Silverado, Fusion, 142mm	WTB Silverado, Fusion, 142mm	WTB Silverado, Fusion, 142mm	WTB Silverado, Fusion, 142mm	WTB Silverado, Ti, 142mm
POWER	—	—	—	SRAM AXS Battery & Power Pack Charger	SRAM AXS Battery & Power Pack Charger
PRICING	\$4,999	\$5,699	\$6,499	\$7,199	\$8,499
OPTIONAL UPGRADE	—	—	i9 Carbon Wheelset: +\$1,400	i9 Carbon Wheelset: +\$1,400	i9 Carbon Wheelset: +\$1,400

SPECIFICATIONS SUBJECT TO CHANGE WITHOUT NOTICE

RIPLY GEOMETRY

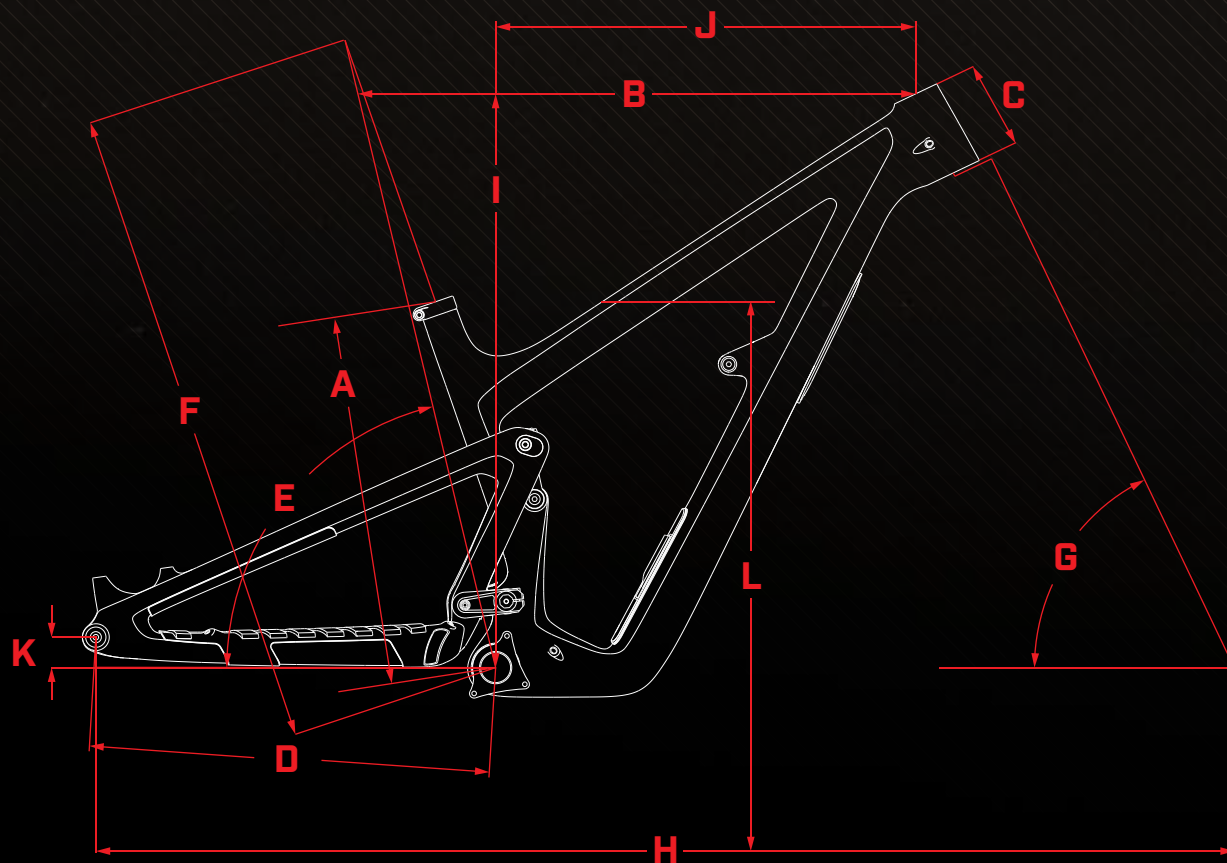

140MM FORK (555MM AXLE TO CROWN)

SIZE		SMALL	MEDIUM	EXTRA MEDIUM	LARGE	X-LARGE
SEAT TUBE MM	A	395	400	416	457	477
TOP TUBE MM	B	577	604	629	654	684
HEAD TUBE MM	C	85	95	110	125	140
CHAINSTAY MM (29" standard on Ripley)	D	29": 436		29": 437	29": 440	29": 442
		MX: 433		MX: 434	MX: 436	MX: 438
SEAT TUBE ANGLE	E	77.4°	76.9°		77.4°	77.9°
SADDLE HEIGHT FOR SEAT TUBE ANGLE MM	F	650	700	745	790	830
HEAD TUBE ANGLE	G	64.9°				
WHEELBASE MM	H	1187	1211	1241	1279	1321
STACK MM	I	613	619	629	640	650
REACH MM	J	440	460	483	511	545
BB DROP MM (Based on 29" wheels)	K	48	45	42	39	36
BB HEIGHT* MM		326	329	332	335	338
STANDOVER MM	L	680	721	744	759	772
RECOMMENDED SEATPOST DROP MM		140	170	185	213	
CRANK LENGTH MM		165		170		
TIRE SIZE IN		2.35-2.5				
WATER BOTTLE SIZE		1 x 22oz	1 x 26oz			

*With Maxxis 29x2.4 WT tires = 748mm diameter, 27.5x2.5 WT rear tires = 708mm diameter.



RIPLEY BUILD KITS

FRAME ONLY					
FRAME ONLY	\$3,699				
FORK	Fox Float 34, Performance Series, Grip, 140mm, 29", 110mm x 15mm	Fox Float 34, Performance Series, Grip, 140mm, 29", 110mm x 15mm	Fox Float 34, Factory Series, Grip X, 140mm, 29", 110mm x 15mm	Fox Float 34, Factory Series, Grip X, 140mm, 29", 110mm x 15mm	Fox Float 34, Factory Series, Grip X, 140mm, 29", 110mm x 15mm
SHOCK	Fox Float, Factory Series, DPS w/EVOL, 210mm x 52.5mm	Fox Float, Factory Series, DPS w/EVOL, 210mm x 52.5mm	Fox Float, Factory Series, DPS w/EVOL, 210mm x 52.5mm	Fox Float, Factory Series, DPS w/EVOL, 210mm x 52.5mm	Fox Float, Factory Series, DPS w/EVOL, 210mm x 52.5mm
RIMS (F/R)	Blackbird Send Alloy, 32 Hole, 29"	Blackbird Send Alloy, 32 Hole, 29"	Blackbird Send Alloy, 32 Hole, 29"	Blackbird Send Alloy, 32 Hole, 29"	Blackbird Send Alloy, 32 Hole, 29"
HUBS (F/R)	Ibis Logo, 32H, 6-Bolt, F/R: Boost	Ibis Logo, 32H, 6-Bolt, F/R: Boost	Ibis Logo, 32H, 6-Bolt, F/R: Boost	Ibis Logo, 32H, 6-Bolt, F/R: Boost	Ibis Logo, 32H, 6-Bolt, F/R: Boost
SPOKES/NIPPLES	Sapim, Dlight Double Butted, 14g Alloy	Sapim, Dlight Double Butted, 14g Alloy	Sapim, Dlight Double Butted, 14g Alloy	Sapim, Dlight Double Butted, 14g Alloy	Sapim, Dlight Double Butted, 14g Alloy
FRONT TIRE	Maxxis DHR2, 29"x 2.4", Exo, TR	Maxxis DHR2, 29"x 2.4", Exo, TR	Maxxis DHR2, 29"x 2.4", Exo, TR	Maxxis DHR2, 29"x 2.4", Exo, TR	Maxxis DHR2, 29"x 2.4", Exo, TR
REAR TIRE	Maxxis Rekon, 29"x 2.4", Exo, TR	Maxxis Rekon, 29"x 2.4", Exo, TR	Maxxis Rekon, 29"x 2.4", Exo, TR	Maxxis Rekon, 29"x 2.4", Exo, TR	Maxxis Rekon, 29"x 2.4", Exo, TR
BRAKES	Shimano Deore, M6120, 4-Piston	Shimano XT, M8120, 4-Piston	Shimano XT, M8120, 4-Piston	SRAM G2, 4-Piston	SRAM Code RSC, 4-Piston
ROTOR (F/R)	Shimano SM-RT66, F/R: 180mm	Shimano SM-RT66, F/R: 180mm	Shimano SM-RT66, F/R: 180mm	SRAM, Centerline F/R: 180mm	SRAM, Centerline F/R: 180mm
CRANKSET	Shimano Deore, M6120, 24mm Spindle, S-M: 165mm, XM-XL: 170mm	Shimano SLX, M7120, 24mm Spindle, S-M: 165mm, XM-XL: 170mm	Shimano XT, M8120, 24mm Spindle, 30T Alloy Ring, S-M: 165mm, XM-XL: 170mm	SRAM GX, Eagle Transmission, DUB, SM-MD: 165mm, XM-XL: 170mm	SRAM X0, Eagle Transmission, DUB, SM-MD: 165mm, XM-XL: 170mm
BOTTOM BRACKET	Shimano, SM-BB52	Shimano, SM-BB52	Shimano XT MT800	SRAM DUB BSA	SRAM DUB BSA
REAR DERAILLEUR	Shimano Deore, M6100, Shadow Plus	Shimano SLX, M7100, Shadow Plus	Shimano XT, M8100, Shadow Plus	SRAM GX, Eagle Transmission	SRAM X0, Eagle Transmission
SHIFTER	Shimano Deore, M6100	Shimano SLX, M7100	Shimano XT, M8100	SRAM GX, Eagle Transmission	SRAM X0, Eagle Transmission
CASSETTE	Shimano Deore, M6100, 10-51T	Shimano SLX, M7100, 10-51T	Shimano XT, M8100, 10-51T	SRAM GX, Eagle Transmission, 10-52T	SRAM X0, Eagle Transmission, 10-52T
CHAIN	Shimano Deore, M6100	Shimano SLX, M7100	Shimano XT M8100	SRAM GX, Eagle Transmission	SRAM X0, Eagle Transmission
HEADSET	Cane Creek 40: ZS44/ZS56	Cane Creek 40: ZS44/ZS56	Cane Creek 40: ZS44/ZS56	Cane Creek 40: ZS44/ZS56	Cane Creek 40: ZS44/ZS56
GRIPS	Lizard Skin Charger Evo	Lizard Skin Charger Evo	Lizard Skin Charger Evo	Lizard Skin Charger Evo	Lizard Skin Charger Evo
HANDLEBAR	Ibis HiFi, 31.8mm, 800mm	Ibis HiFi, 31.8mm, 800mm	Blackbird HiFi, 35mm, 800mm	Blackbird HiFi, 35mm, 800mm	Blackbird HiFi, 35mm, 800mm
STEM	Ibis, 31.8mm, S-M: 40mm, XM-XL: 50mm	Ibis, 31.8mm, S-M: 40mm, XM-XL: 50mm	Blackbird, 35mm, S-M: 35mm, XM-XL: 50mm	Blackbird, 35mm, S-M: 35mm, XM-XL: 50mm	Blackbird, 35mm, S-M: 35mm, XM-XL: 50mm
SEATPOST	KS i-Rage Dropper, 34.9mm, S: 125mm, M: 150mm, XM: 170mm, L-XL: 190	Bike Yoke Revive Dropper, 34.9mm, S: 125mm, M: 160mm, XM: 185mm, L-XL: 213mm	Bike Yoke Revive Dropper, 34.9mm, S: 125mm, M: 160mm, XM: 185mm, L-XL: 213mm	Bike Yoke Revive Dropper, 34.9mm, S: 125mm, M: 160mm, XM: 185mm, L-XL: 213mm	Bike Yoke Revive Dropper, 34.9mm, S: 125mm, M: 160mm, XM: 185mm, L-XL: 213mm
SADDLE	WTB Silverado, Fusion, 142mm	WTB Silverado, Fusion, 142mm	WTB Silverado, Fusion, 142mm	WTB Silverado, Fusion, 142mm	WTB Silverado, Ti, 142mm
POWER	—	—	—	SRAM AXS Battery & Power Pack Charger	SRAM AXS Battery & Power Pack Charger
PRICING	\$4,999	\$5,599	\$6,699	\$7,699	\$8,199
OPTIONAL UPGRADE	—	—	i9 Carbon Wheelset: +\$1,400	i9 Carbon Wheelset: +\$1,400	i9 Carbon Wheelset: +\$1,400

SPECIFICATIONS SUBJECT TO CHANGE WITHOUT NOTICE



IBISCYCLES.COM