

Oil in Water Analysers
Solids in Water Analysers
Particle Size Analysers



Process Imaging π **g**



Process Imaging MEx1A



Process Imaging MEx1A Zone 1 Certified Combined Analyser and Computer

This mobile all in one unit combines the analyser and control computer into a single air purged enclosure with ATEX or IECEx Zone 1 certification. The unit weighs 34.4 kgs and its compact nature and small footprint makes it easy to transport with minimal set-up time out of the box for generating data quickly. This analyser comes with a detachable keyboard and mouse trackpad.

Its stainless steel construction and flow cell rated for continuous use at 120 Bar (1740 PSI/12000 kPa) with the capability to operate with process liquid temperatures of up to 120°C (248°F) make the analyser ideal for use in harsh environments. Options for higher rated temperatures and pressures are available on request.

The portable nature of the analyser enclosure allows installation very close to the sample point to ensure the best possible sampling is achieved and the ability to work with flow velocities of up to 5ms⁻¹ ensure great response to process changes and minimal flow control requirements. There is no upstream sample conditioning required.

It is supplied with fully featured control software capable of complex particle analysis and has an easily accessible USB port for transferring data from the analyser when required with the use of a Ex rated USB memory stick.

Available for either 110V or 230V 50H/60Hz power supplies, the MEx1A uses instrument air to achieve the hazardous area rating. The MEx1A is supplied with a thermostatically controlled vortex cooler that uses the same instrument air supply to maintain a constant temperature within the enclosure despite the external hot working environment. This allows for operation in tropical and desert locations.

The analyser is supplied with a range of accessories including high pressure sampling hoses (0-120 bar rated) and flight cases for easy transportation of this robust investigative tool. Hazardous area transformers can also be supplied to enable operation with alternative voltages.

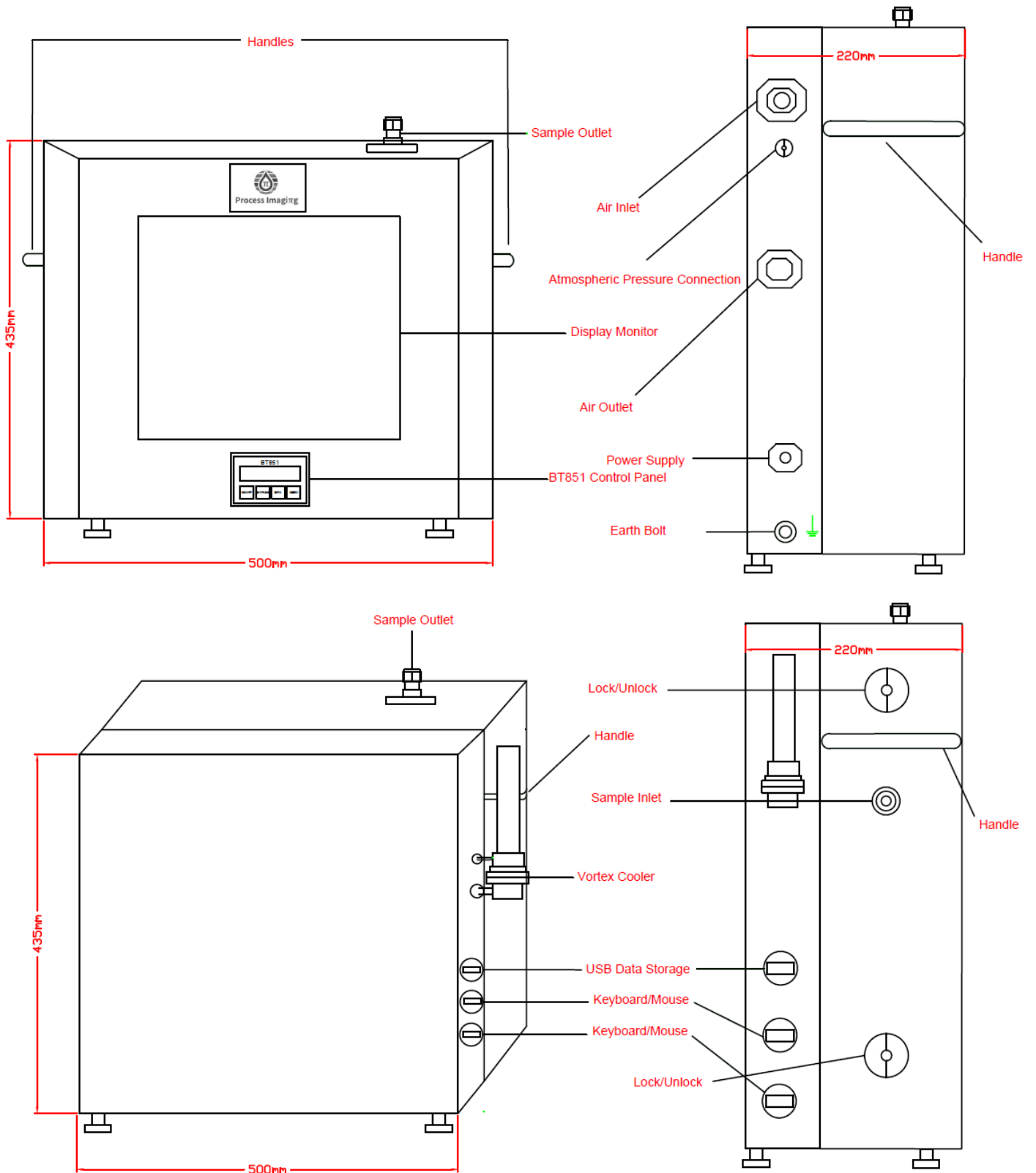

Process Imaging MEx1A General Arrangement Drawing

Top—Front and Left view

Bottom—Back and Right view



Process Imaging MEx1A Data Sheet

General			
1.01	Type	Droplet & Particle Analyser	
1.02	Manufacturer	Process Imaging Limited	
1.03	Model	MEx1A	
1.04	Sample Temp Limits	0 – 120°C (32 – 248 °F)	
1.05	Max Operating Pressure	120 Bar (1740 PSI)	
1.06	System Description	Portable ATEX or IECEx certified analyser unit	1
1.07	Tag Number	TBC	
1.08	Instrument Fittings	Swagelok SS316 1/4 and 1/2"	
Instrument Characteristics			
2.01	Accuracy	±2% Full Scale	
2.02	Repeatability	±1.5%	
2.03	Linearity	±7.5% in range 0 – 400PPM	
2.04	Drop Size Range	1.2 – 150 microns	
2.05	Particle Size Range	1.2 – 150 microns	
2.06	Concentration	0 – 2500 ppmV	
2.07	Data Outputs	Data displayed on control computer screen and can be transferred to the provided Zone 1 rated USB Memory Stick	3
2.08	Flow Rates	Flow through analyser	Up to 4 litres/min
Physical Characteristics			
3.01	Sample Feed	Typically ½" sample tubing/flexible hose	
3.02	Analyser Drain	Typically ½" sample tubing/flexible hose	
3.03	Wash Connection	N/A	
3.04	Purge Air Connection	½" sample tubing/flexible hose with use of provided air filter regulator	
3.05	Mounting	Analyser	Analyser Field Enclosure
		Control Computer	Within analyser enclosure
3.06	Weights (dry)	Analyser Enclosure	34.4.Kgs
		Keyboard Enclosure	3.9 Kgs
3.07	Materials	Analyser Wetted	316SS, Viton, Industrial Sapphire
		Analyser & Keyboard Enclosure	316 SS
3.08	Enclosure Rating	Analyser	IP55
3.09	Hazardous Area	Zone 1	
3.10	Classifications	Ex II 2 G Ex px II T4	
3.11	Cable Gland	Hawke M20	
3.12	Environment	Analyser Enclosure	-20 – 55°C Ambient
Electrical Data			
4.01	Supply Voltage	Analyser Field Cabinet	110V or 230V 50/60 Hz
4.02	Consumption	Analyser Field Cabinet	150 Watts (Peak)
Supply Requirements			
5.01	Purge	Clean dry air, minimum 1.3 litres/second @ 4 – 6 bar	
Notes			
1	Certification by MDoC from Gönheimer Elektronik GmbH in accordance with ATEX or IECEx for Zone 1		
2	Alternate wetted materials can be supplied to meet fluid specifications		
3	Data can be provided as Serial data by Modbus TCP/IP for all data and alarms if necessary		
4	Power supply is single voltage (either 110 or 230V only) and must be specified at the time of order		



Process Imagiπg