



Pablo Ortega López

*Illustration / 3D Art /
Visual Development*

2021

Index



Illustration

Pablo Ortega López

www.polanimation.com



[Please click here to learn more about this illustration](#)

Arutam

The Greatest Spirit of the Jungle
(Procreate for iPad - Arutam)

The Greatest Spirit of the Jungle (2017)

[Please click here to watch the time lapse](#)



Alma

When her galleon sinks, 'Alma' fell to the bottom of the sea (2017 / Sketches for iPad, Photoshop)

[Please click here to watch the time lapse](#)



Portrait of Hilary Hahn

(2020 / Procreate)

[Please click here to watch the time lapse](#)



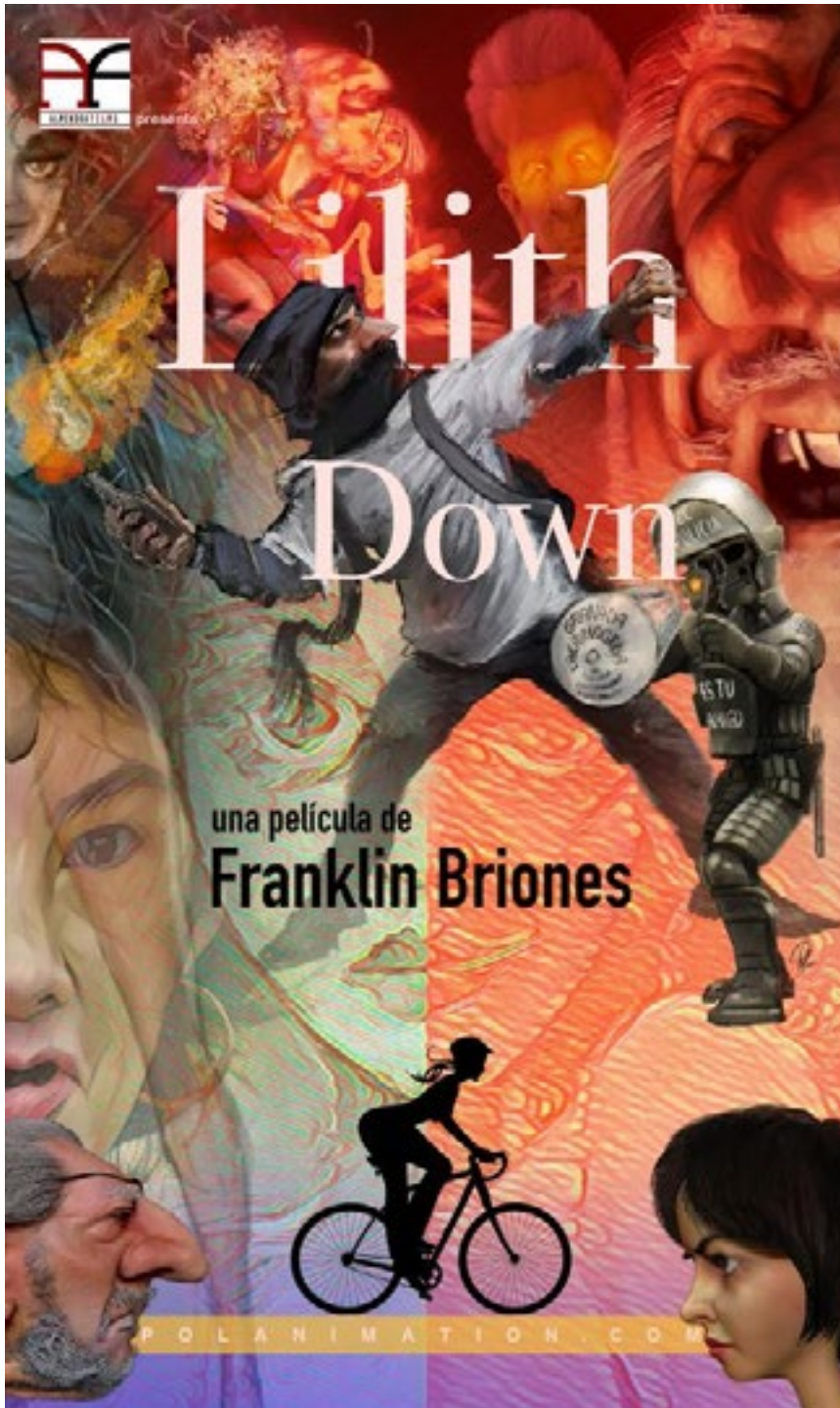

Poster of “Lilith Down”

I made this poster mixing 2D and 3D illustration, for the movie “Lilith Down”, written and directed by Franklin Briones (Procreate, Maya, Blender and Photoshop -2020)

[Please click here to learn more about my work on “Lilith Down”](#)



AI

I made this illustration decades ago for “El Comercio”, Ecuadorian newspaper (Watercolor-1993)

[Please click here to learn more about my illustration work.](#)

Scientific illustration
(2010 / Photoshop)

[Please click here to learn more about my scientific illustration work.](#)





Taquea

Inspired in an Amazon legend, my story crosses the centuries to put face to face great civilizations from different ages (Procreate, Maya, Modo and Photoshop -2020)

[Please click here to learn more about this project.](#)



Tom Brady

Digital portrait of one of the best football players ever (Procreate -2021)

[Please click here to learn more about my illustration work.](#)



Joe Montana
Digital portrait of one of
the best football players
ever (Procreate -2021)

[Please click here to
learn more about my
illustration work.](#)

Mazda 5 - Seat
Technical illustration
(Autodesk Maya and
Blender - 2021)

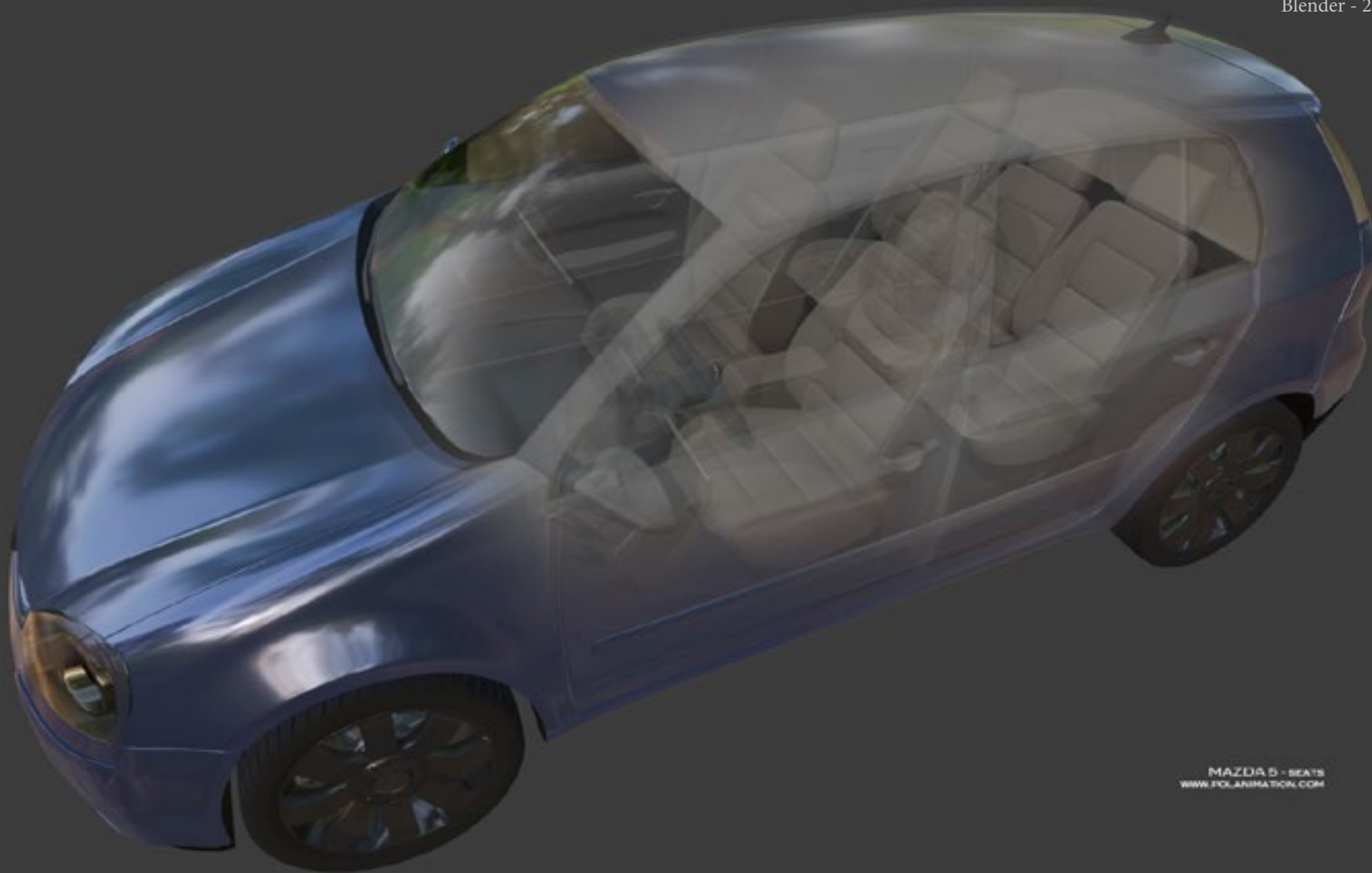

MAZDA 5 - SEATS
WWW.POLANIMATION.COM

[Please click here to learn more about my technical illustration work.](https://polanimation.com)

Ferrari 812 - Seat
Technical illustration
(MODO - 2020)



[Please click here to learn more about my technical illustration work.](#)

Instructions to built an easel
Technical ilustration
(Blender - 2021)

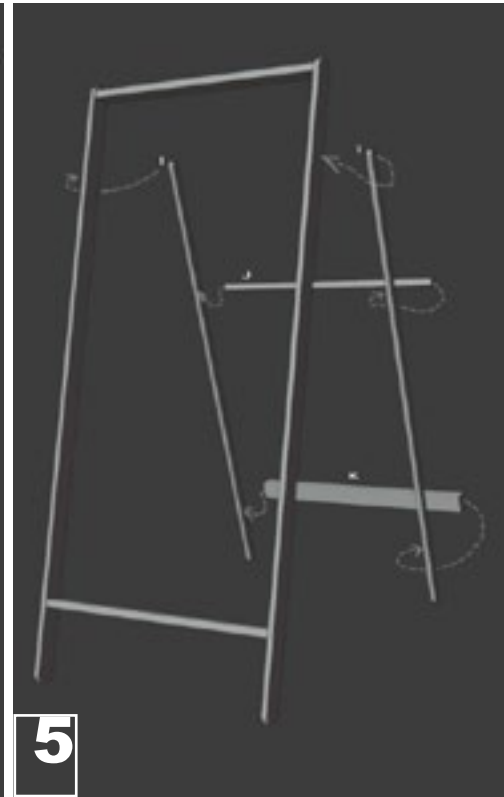
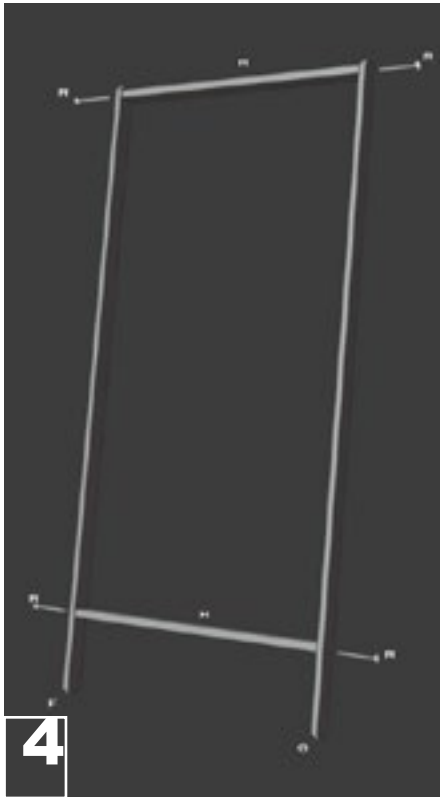
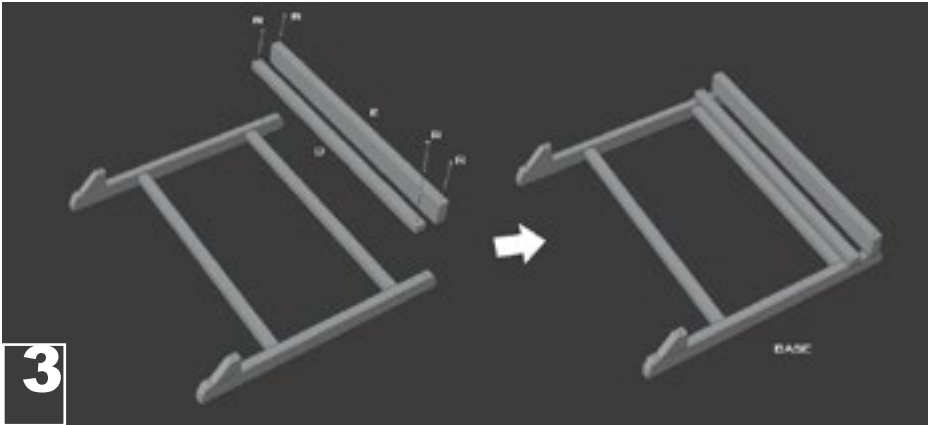
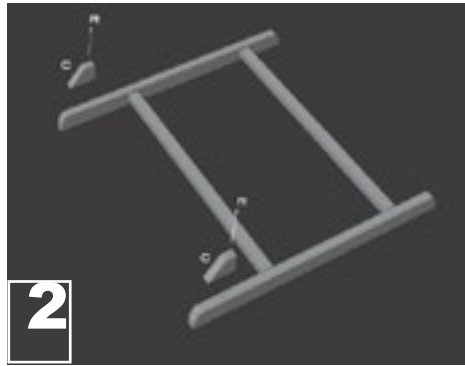
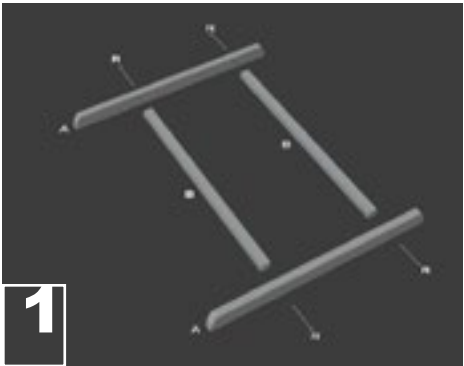
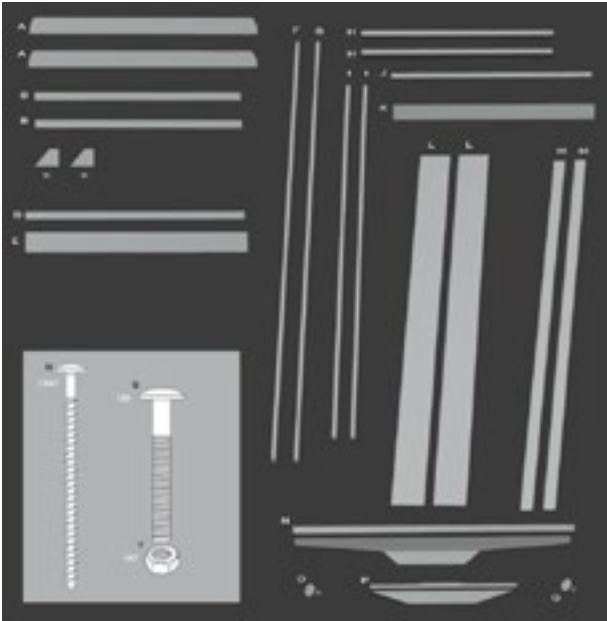

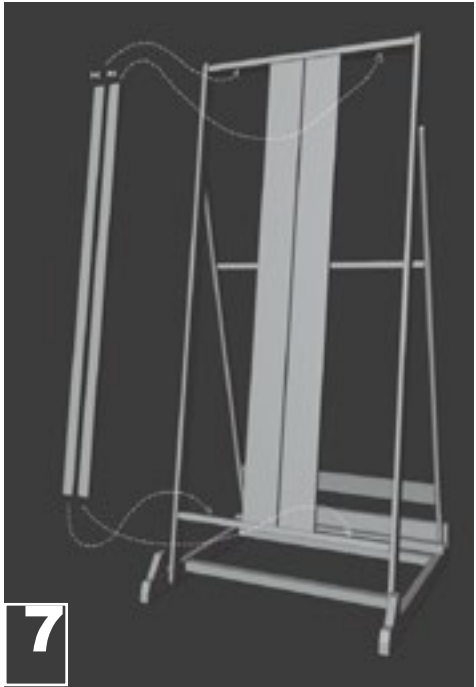
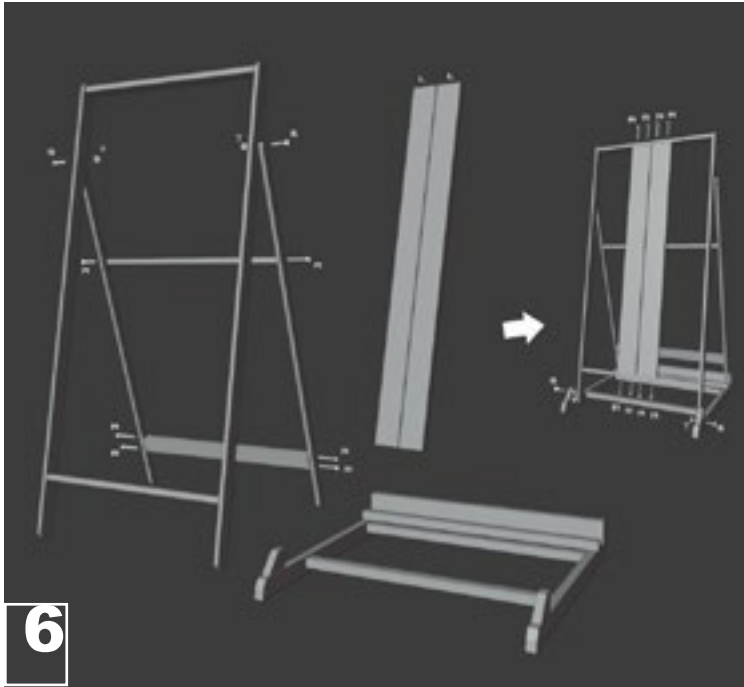

Instructions to built an easel
Technical ilustration
MODO - 2020)

[Please click here to learn more about my technical illustration work.](#)



Characters

Pablo Ortega López

www.polanimation.com

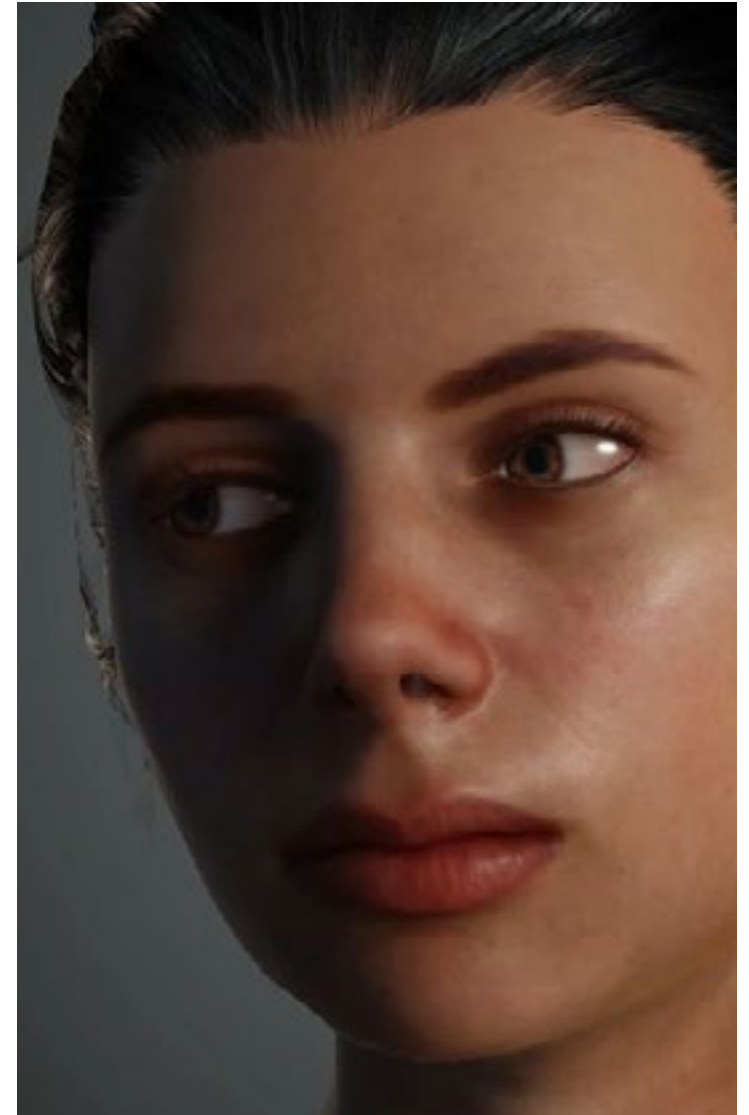
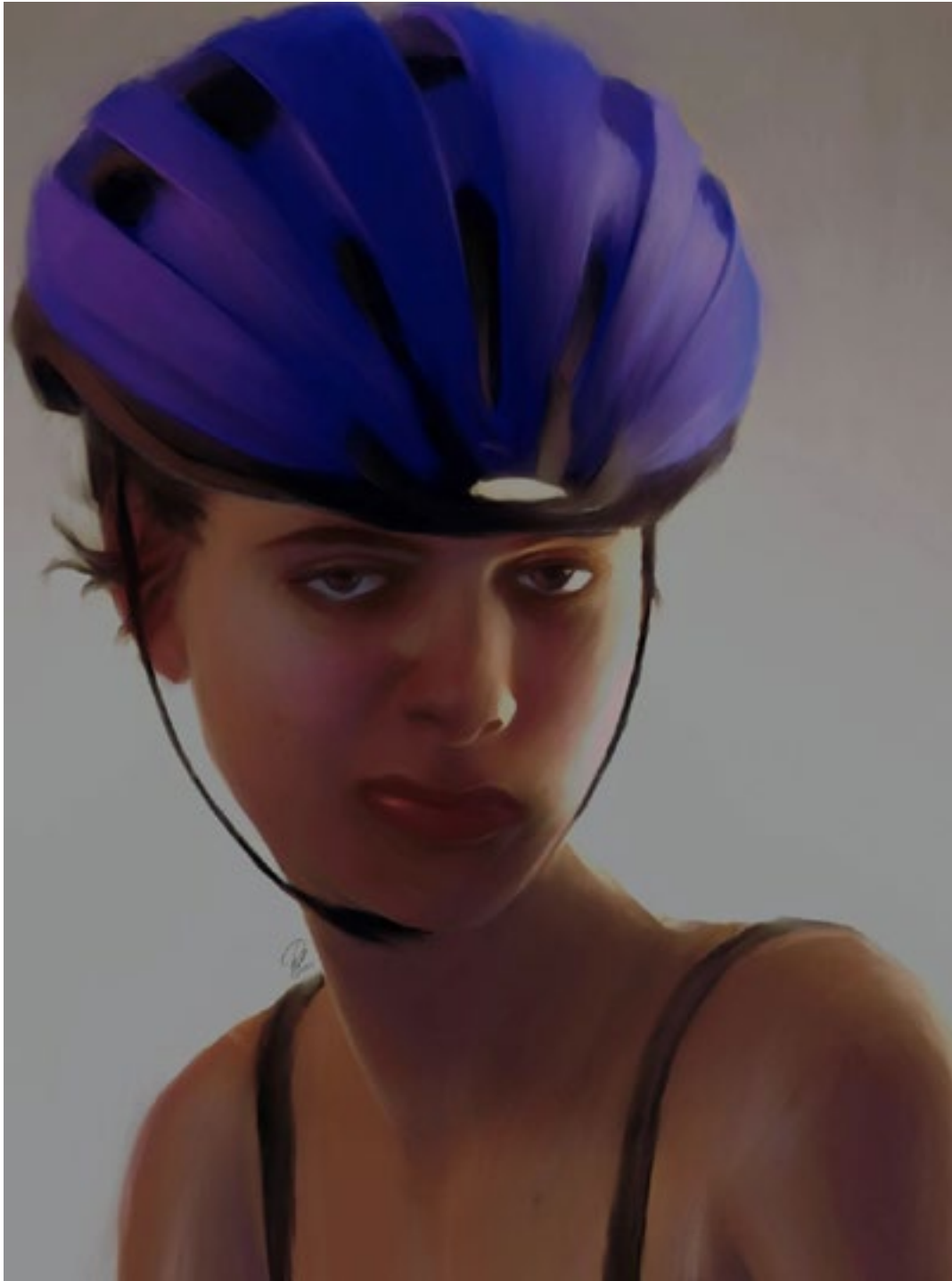

Lilith is a young, brave and smart latin business woman owner of a Foundation dedicated to people with Down Syndrome. In search of funding for her foundation, Lilith comes across the corruption network of the highest echelons of her country. This is my version of Lilith, the main character of “Lilith Down”, the new movie written and directed by Franklin Briones.

- ZBrush and Character Creator



Beatriz, a young woman with Down syndrome, a tragic character in the movie “Lilith Down”.
- ZBrush and Character Creator

Mefisto, the Machiavellian strategist
behind the power in “Ciegiebia”.
- ZBrush, Character Creator and Maya

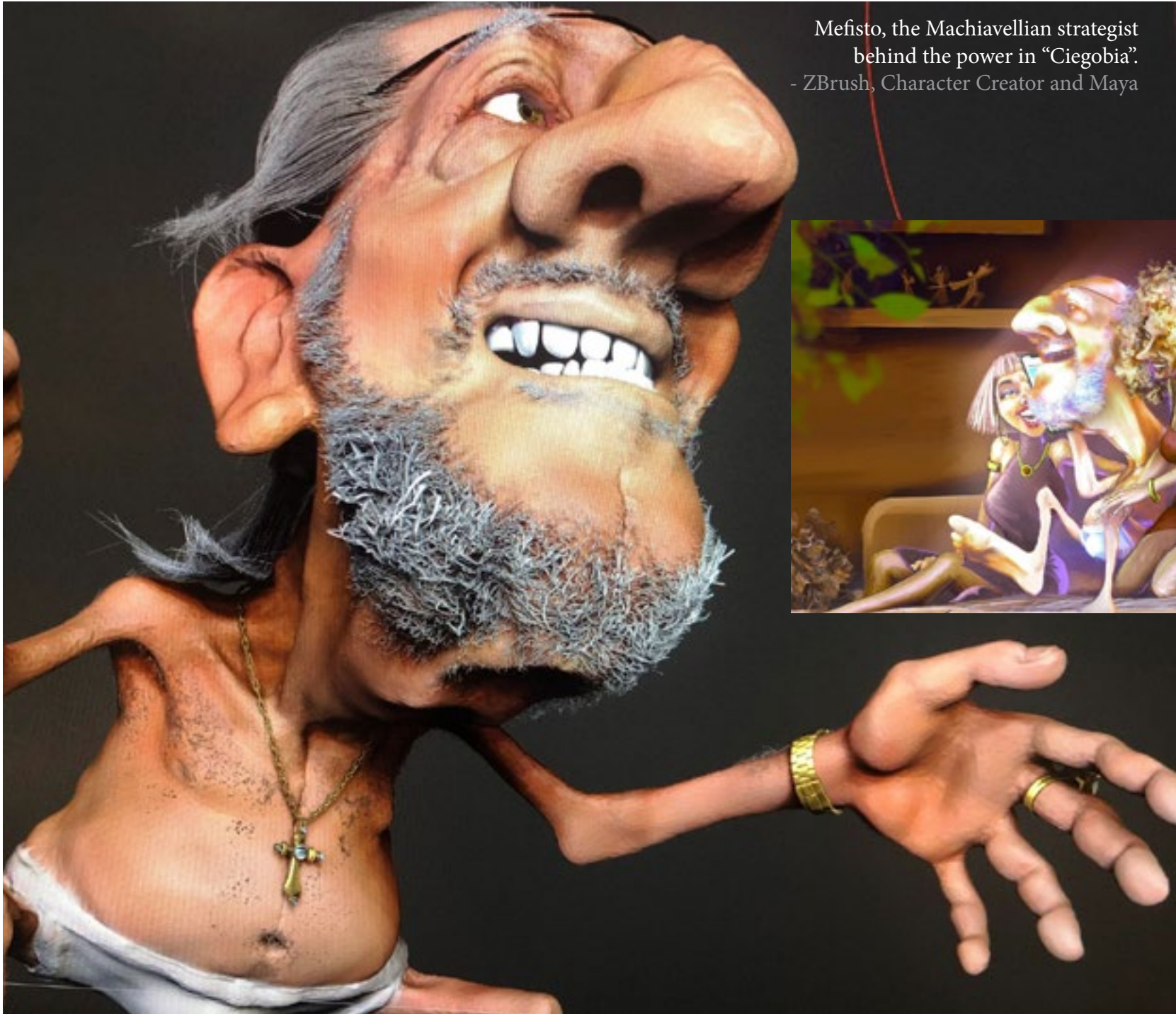

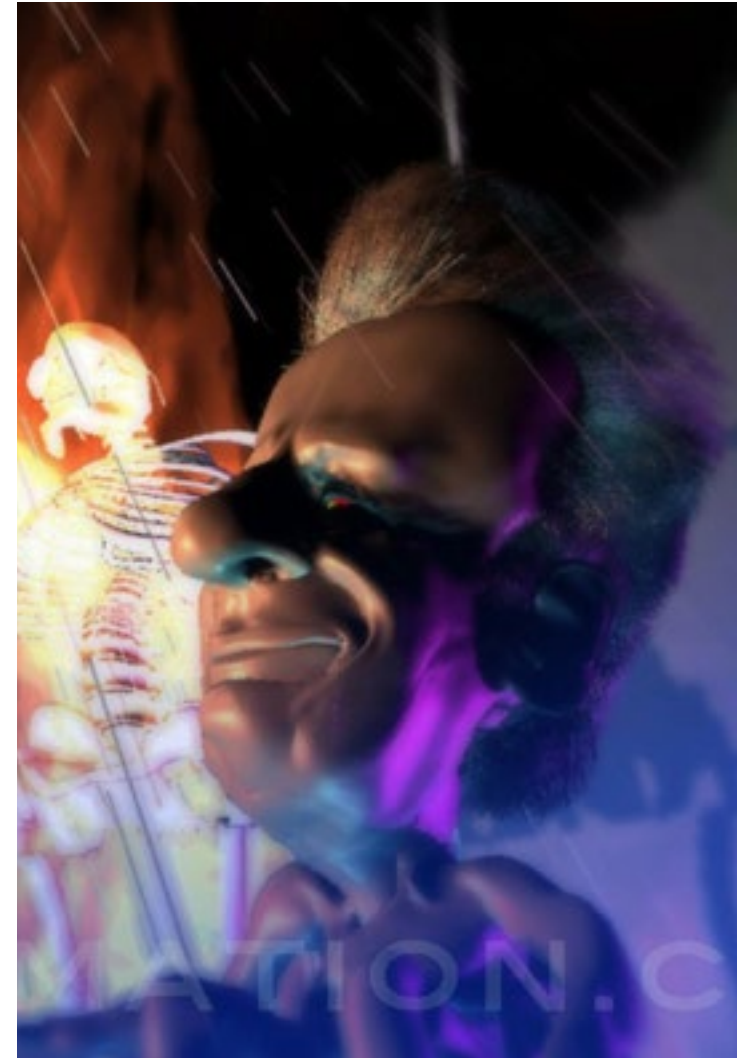
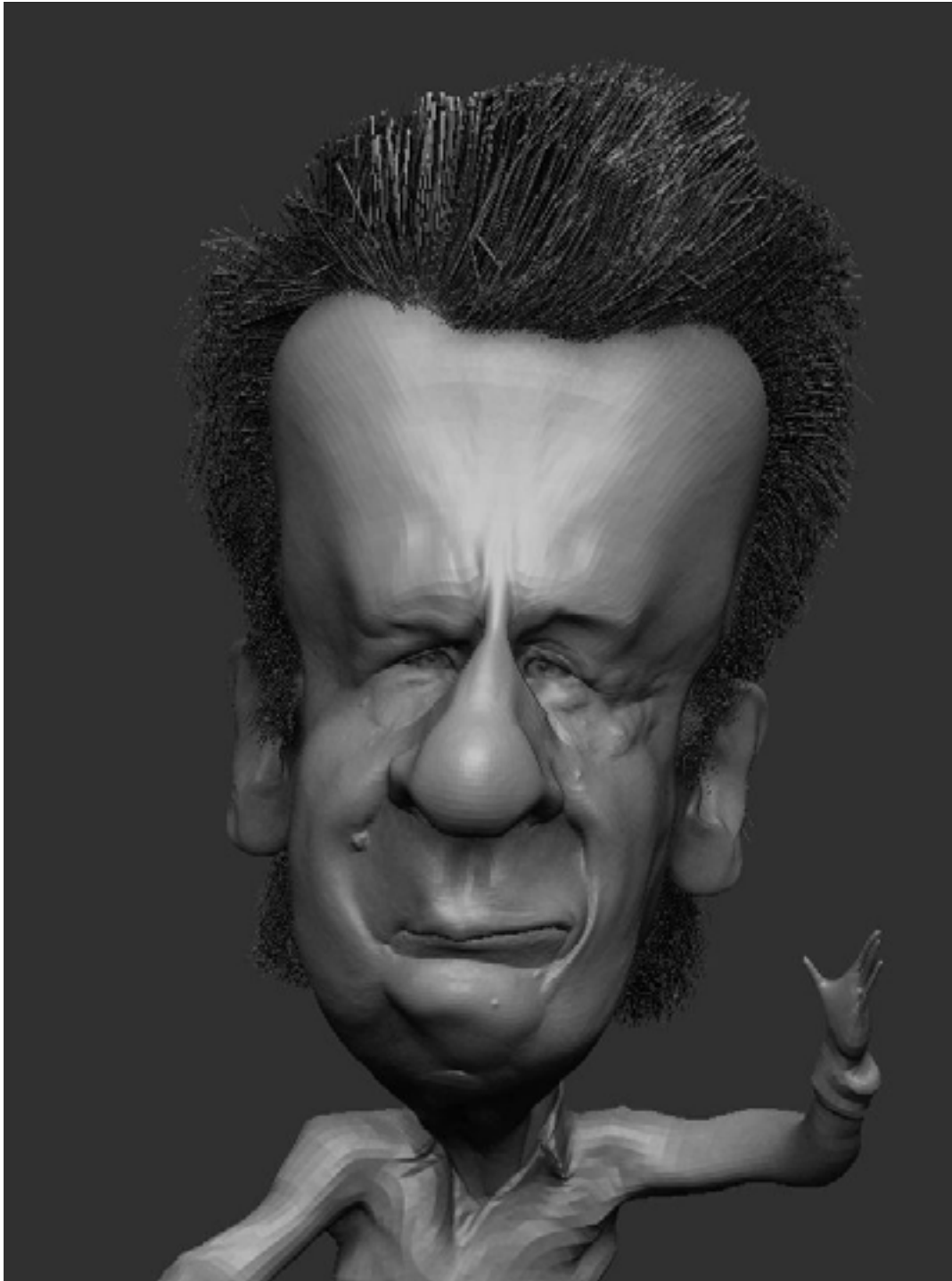

Izcariote, President of Ciegobia (Caricature portrait of the former president of Ecuador Lenin Moreno).
- ZBrush and Maya

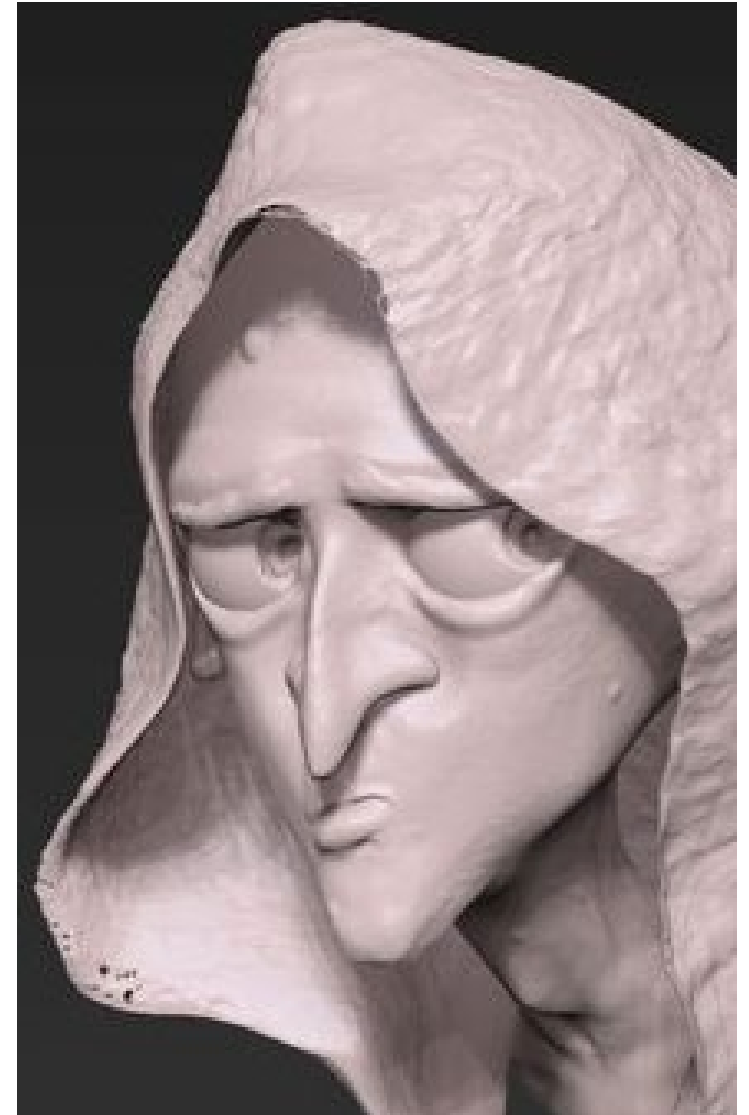

“Daniel, The Altar boy”, locked for life in a monastery in Cadiz-Spain, while reviewing an old book, he discovers the treasure map of Atahualpa. (One of my characters of Posorja, a personal project)
- ZBrush

“Don Quijote”, the naive gentleman in love who goes crazy
- ZBrush, Maya and Photoshop



“El violinista”, the musician who travels to Africa without imagining all the vicissitudes that lie ahead (personal project)
- ZBrush

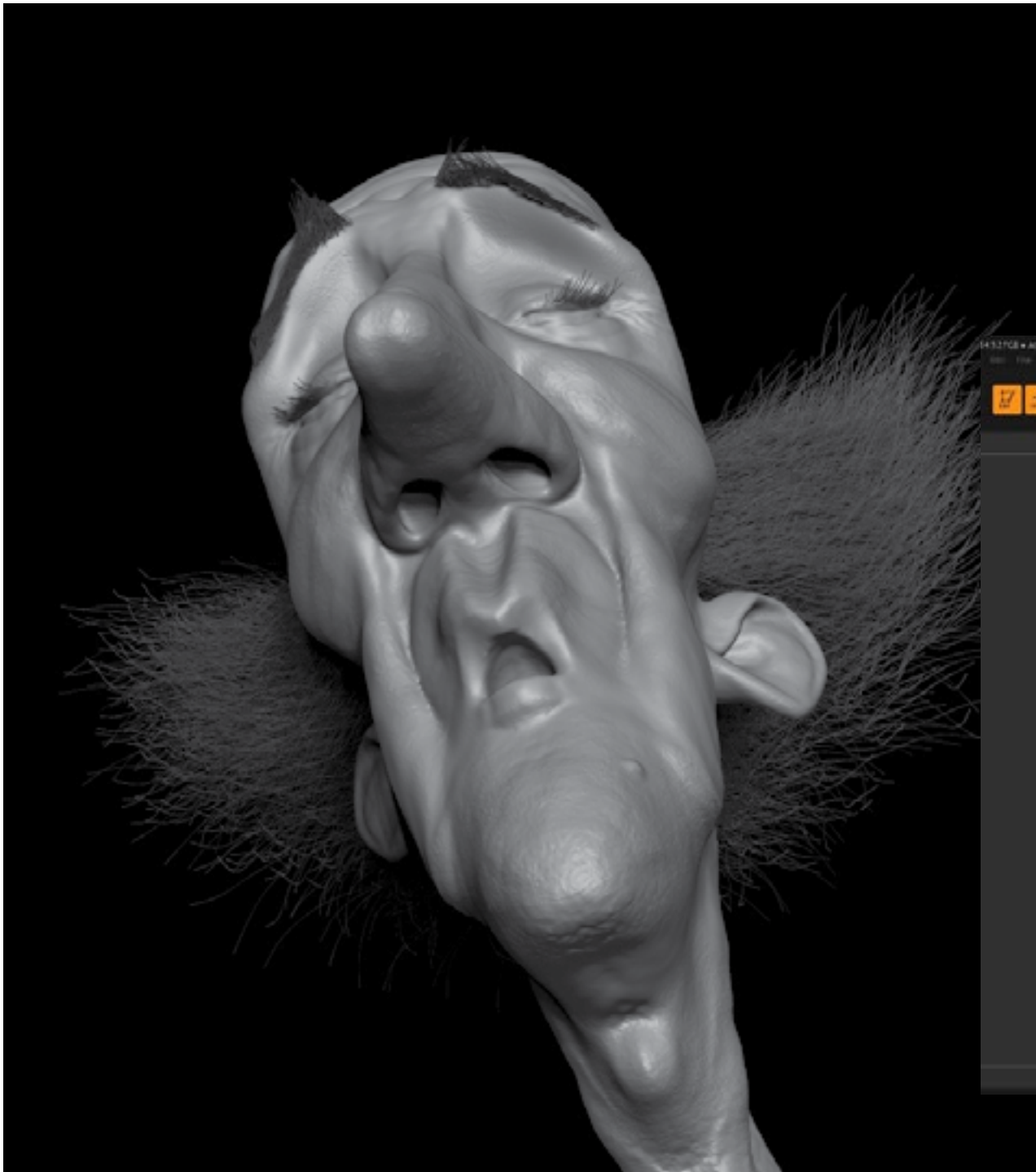

“Dulcinea”, the girl from Don Quixote’s dreams,
one of my characters of “Don Quijote, el último
caballero”, short version of the great book by Cer-
vantes, adapted by Karen Rowan
- ZBrush and Photoshop



“Taquea”, Diabolical spirit of the Amazon rain-forest that devours the warriors who dare to face it.- personal project
- ZBrush, Maya and Photoshop



[Please click here to learn more about my characters.](#)

Environments

Pablo Ortega López

www.polanimation.com





QUILLA ALTAR, COCHASQUÍ

This was a very advanced culture at the last region of the Inca's empire, at the north extreme of Tahuantinsuyo.

No one could approach the kingdom of the Quitucas without being seen from a great distance.

- "POSORJA", personal project

- Maya, ZBrush, Vue, Procreate

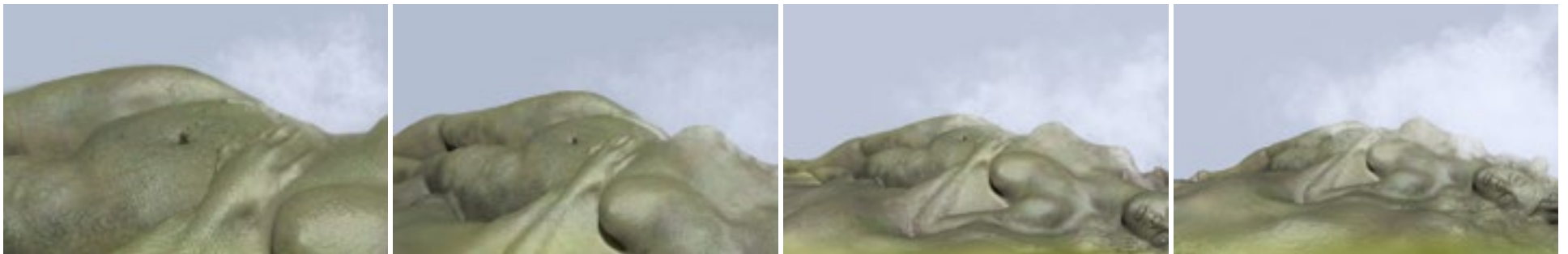

QUILLA ALTAR,
COCHASQUÍ
From the sacred altar in honor of
Quilla, in the goddess's navel, to a
general plan of the monumental
sculpture.
- "POSORJA", personal project
- Maya, ZBrush, Vue, Procreate

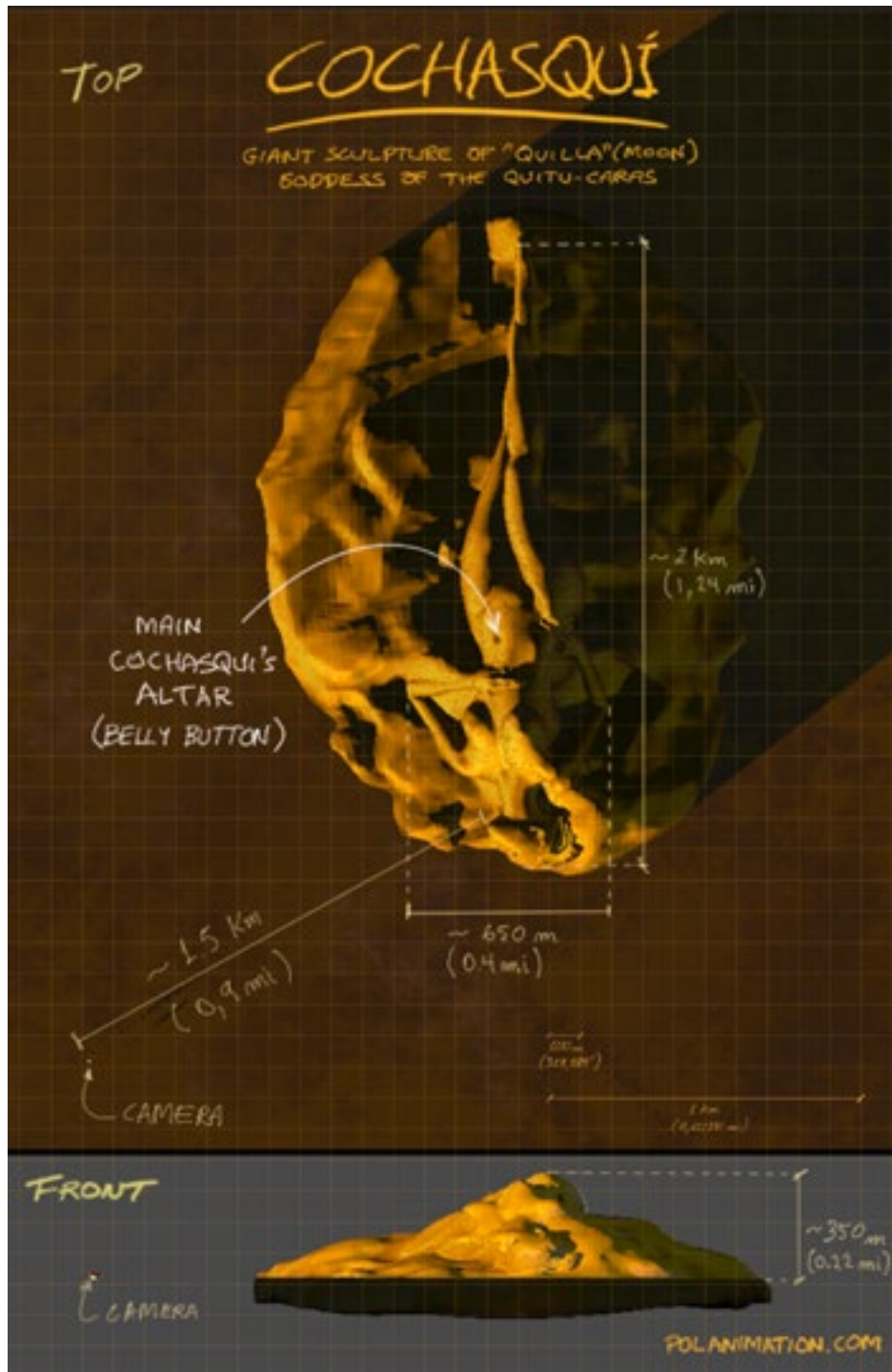

QUILLA ALTAR, COCHASQUÍ
Some measurements
- Maya, ZBrush, Vue, Procreate



“Llanganates”, entrance to the fearsome mountainous region where Rumiñahui is believed to have hidden Atahualpa’s treasure so that the Spanish can never find it - “Posorja”, personal project
- Maya, ZBrush, Vue, Procreate

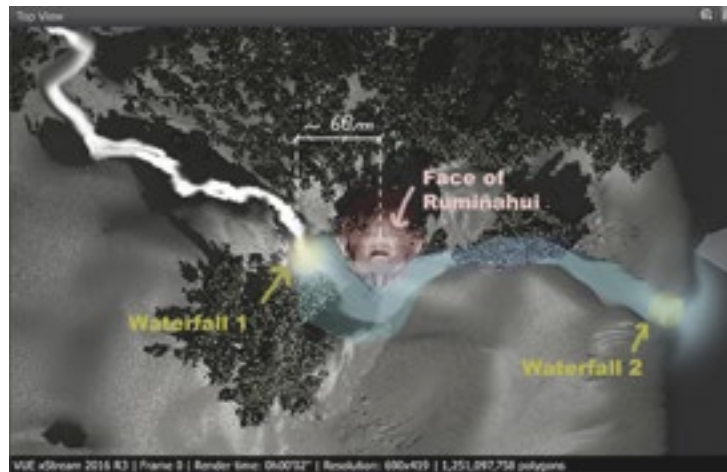
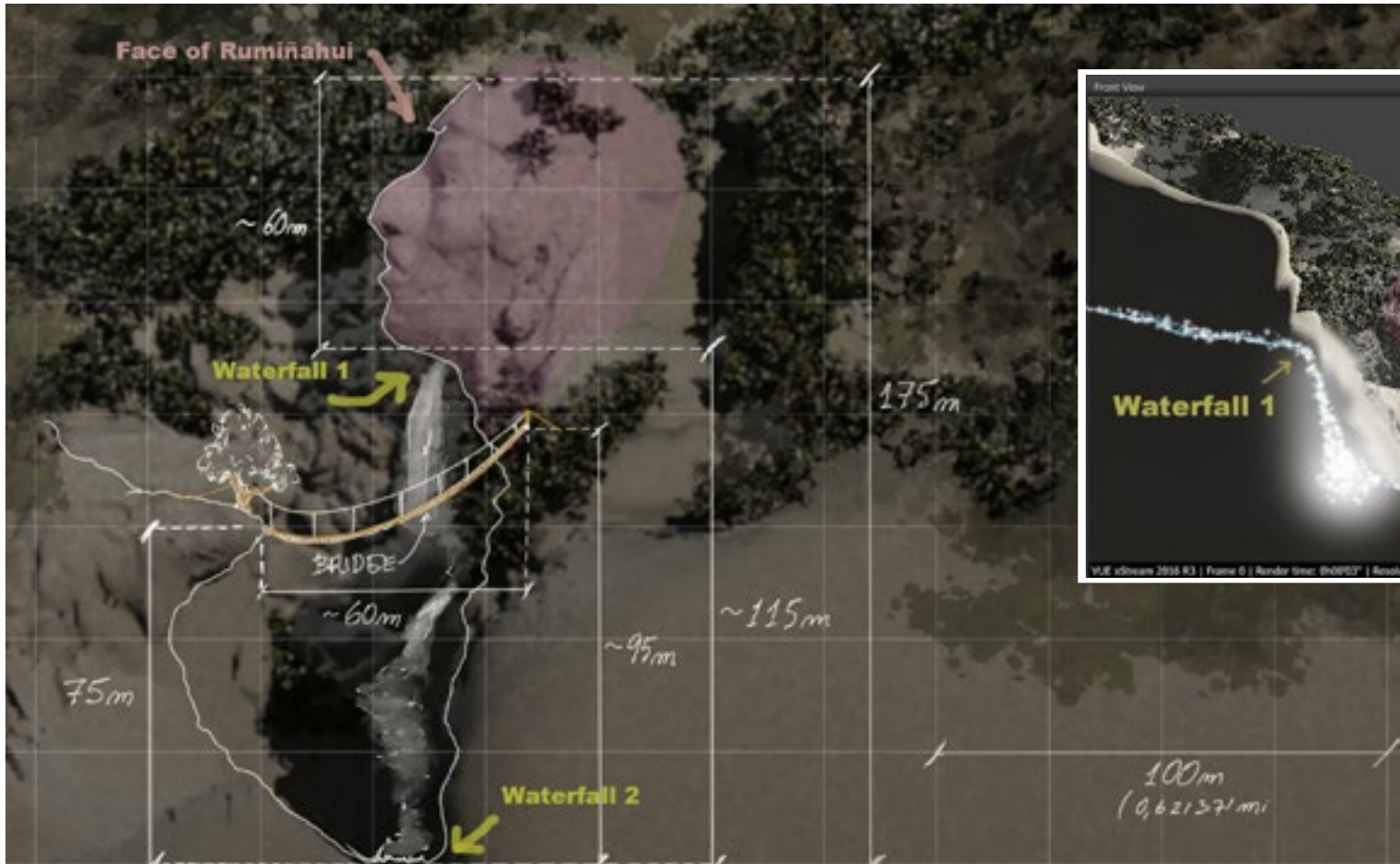

“Llanganates”, some measurements
 - Maya, ZBrush, Vue, Procreate



Napo River
- “El proyecto de aquel Febrero”
written by Carlos Ortega
- Maya, ZBrush, Vue, Procreate

Lita's family coming back home after their stressful beanologist appointment
- "Lita" written by Antonio Luis Gómez Molero
- Maya, ZBrush, Vue, Photoshop



Lita's neighborhood at night
- "Lita" written by Antonio Luis Gómez Molero
- Maya, ZBrush, Vue, Photoshop

[Please click here to learn more about my Environment work](#)

Storyboard

Pablo Ortega López

www.polanimation.com



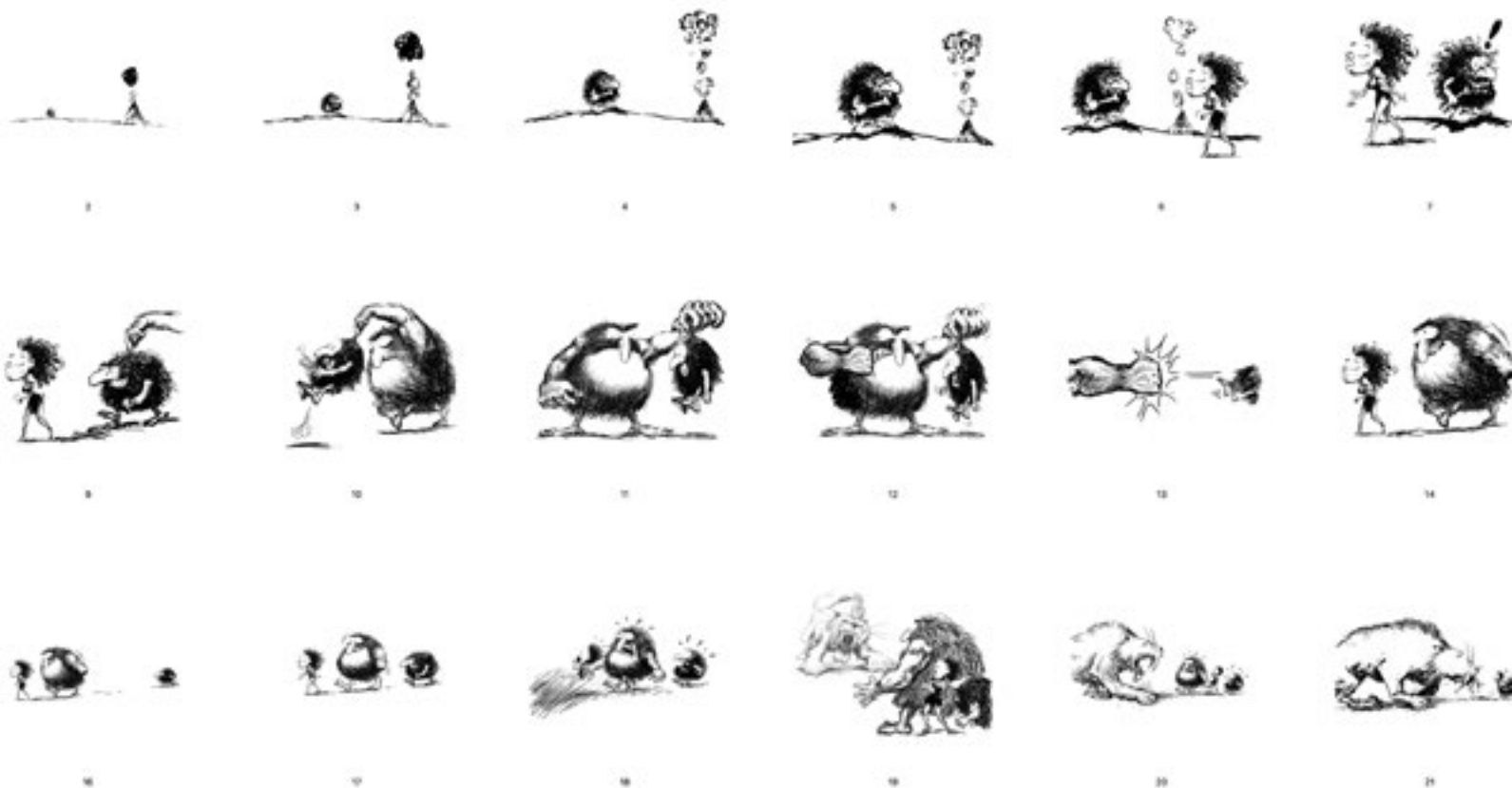

The Caveman

- The harsh story of a primitive man who blindly follows his instincts
(Script and storyboard by Pablo Ortega Lopez -Photoshop - 2007)



Jempe - Arutam

- My fictional story inspired on the Amazon legend of Shuar people.
(Script and storyboard by Pablo Ortega Lopez -Pencils - 2005)

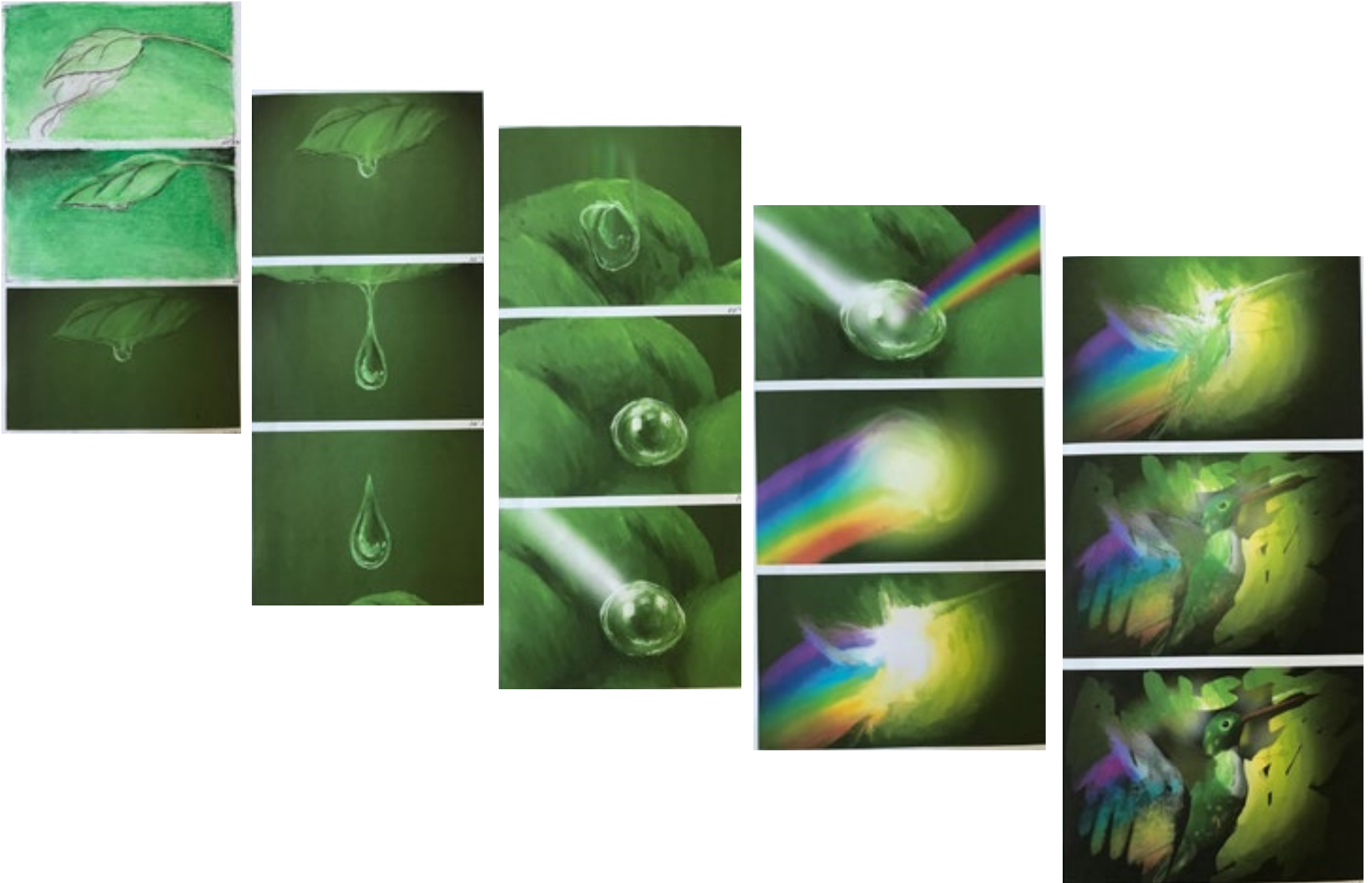

Jempe - The Birth

- My fictional story inspired on the Amazon legend of Shuar people.
(Script and storyboard by Pablo Ortega Lopez -Pencils and Photoshop- 2005)



Posorja

- My fictional story about the Spanish pioneers coming to South America
 (Script and storyboard by Pablo Ortega Lopez -Photoshop - 2011)

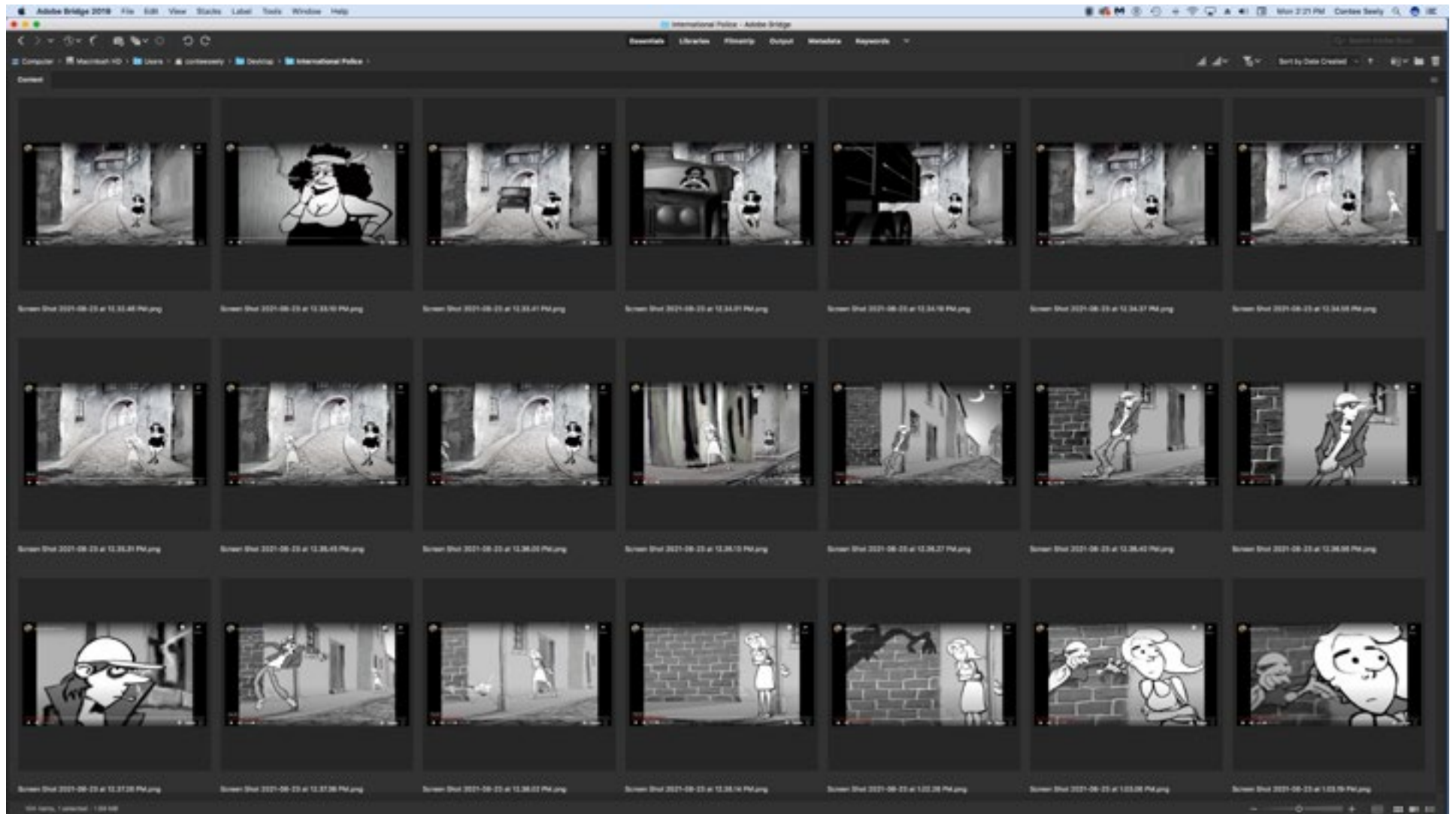

[Please click here to learn more about my Storyboard work.](#)

International Police
- My fictional story about Wonder Woman almost retired, living in Quito-Ecuador-SouthAmerica
(Script and storyboard by Pablo Ortega Lopez -Photoshop - 2009)

VFX

Pablo Ortega López

www.polanimation.com



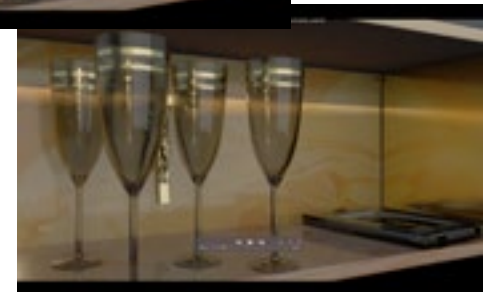
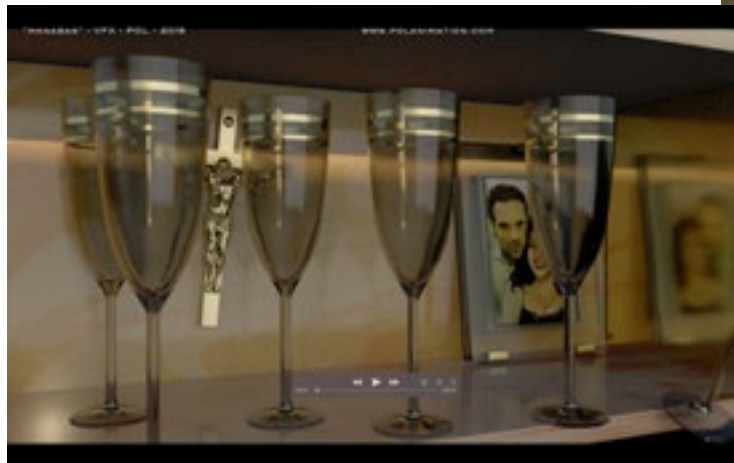
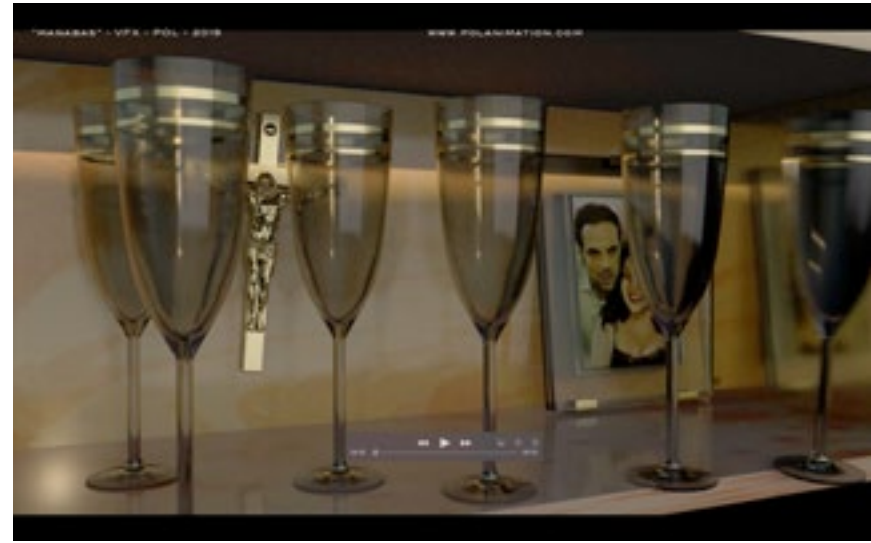
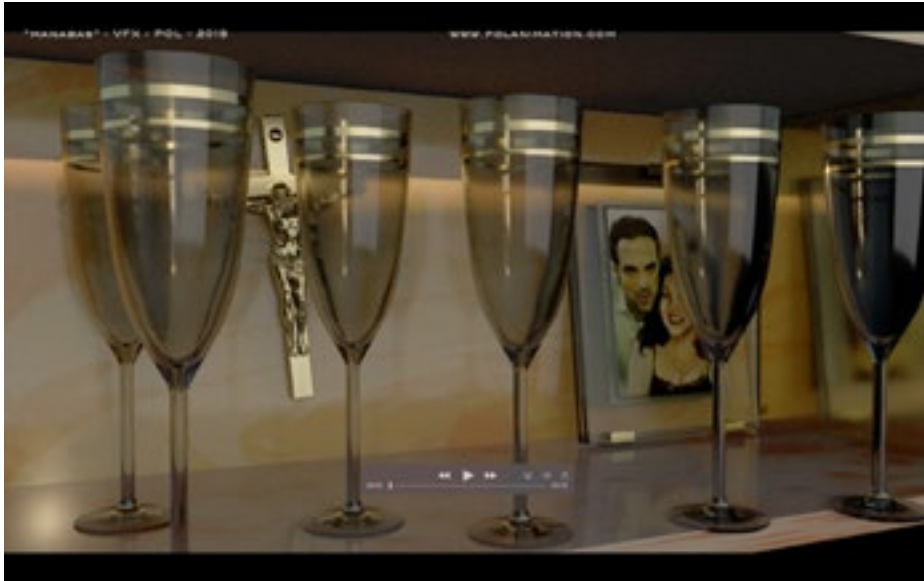

VFX for “Manabas, la vida sigue”
- My visual effects of an earthquake for the movie “Manabas. La vida sigue” written and directed by Franklin Briones
(Script and storyboard by Pablo Ortega Lopez - Maya - 2019)

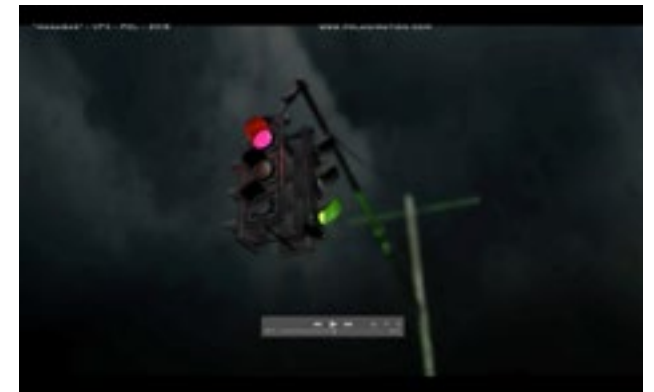
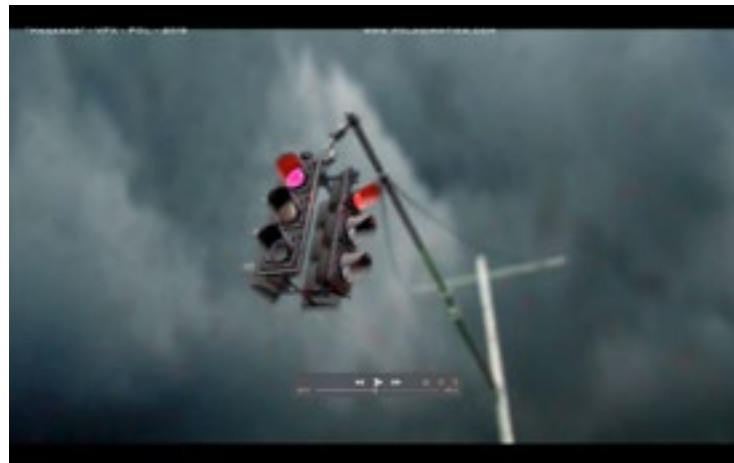

VFX for “Manabas, la vida sigue”
- My visual effects of an earthquake for the movie “Manabas. La vida sigue” written and directed by Franklin Briones
(Script and storyboard by Pablo Ortega Lopez - Maya - 2019)



[Please click here to learn more about my VFX work.](#)

- My visual effects of an earthquake for the movie “Manabas. La vida sigue” written and directed by Franklin Briones (Script and storyboard by Pablo Ortega Lopez -Maya - 2019)

VFX for “Manabas, la vida sigue”



Comic

Pablo Ortega López

www.polanimation.com



...PERO, EN REALIDAD,

NUNCA LE TUVE MIEDO AL MAR...



YO ERA MUY CALLADA DESDE ANTES. LO QUE SÍ ME PASÓ ESE DÍA FUE QUE ME ENAMORÉ PARA SIEMPRE...



¡VÁMONOS PRONTO ESMERALDA, ANTES QUE VUELVA EL TIBURÓN!



DESDE ESE DÍA, YO SOLO QUERTAPABAR EN EL MAR...

¡MAE ALGO, PE SILENCIOSO ¡TÚ NUNCA PASA TODO EL DÍA EN EL MAR!

¿QUÉ HACES DIVORS HORAS EN EL AGUA?
¿JUEGO CON CAJEZA DURA?

¿CAJEZA DURA? ¿QUÉN ES CAJEZA DURA?

ES MI MEJOR AMIGO, EL DELFÍN

¿Y QUÉ HACES CON EL DELFÍN?
LO AYUDO A PESCAR

¡JA, JA! EL DELFÍN NO NECESITA TU AYUDA. EL SABE CÓMO PESCAR.
¿COMIGO PESCA MAR.

AL DÍA SIGUIENTE, MUY TEMPRANO, MI PADRE ME LLEVO AL ACANTILADO, A LA ESCUELA DEL ARTE DE LA DEFENSA...

¡BUENOS DÍAS, MAESTRA CAJIMARI! MI HISA ESMERALDA TIENE 5 AÑOS ¿EN PUEDE ENTRENAR?

ES LA MEJOR EDAD PARA EMPEZAR...
¡HOLA ESMERALDA! ¿PASA?

Posorja

- A graphic novel I am doing, inspired on several legends of The Andes (Procreate and Photoshop - (2011-...))



La Comedia Inmortal
(The immortal comedy)

- My comic version of "The immortal comedy" written by Pablo Palacio (Photoshop - 2002)

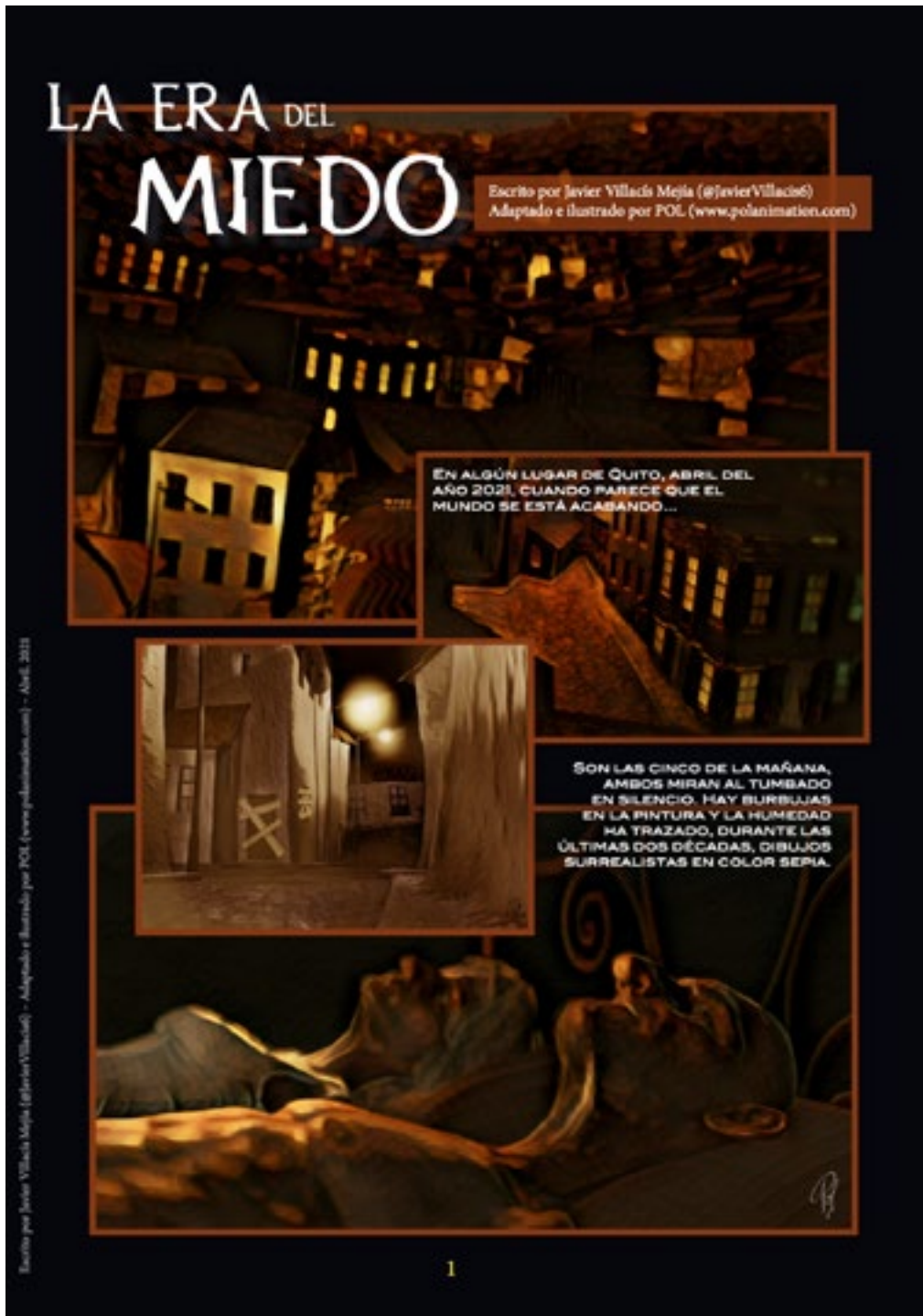

La edad del miedo (The age of Fear)

- My comic version of a short story written by Javier Villacís Mejía (Character Creator, Procreate, Photoshop, Indesign - 2021)

[Please click here to learn more about my comics.](#)