

The image features a solid blue background. A large, irregular shape is formed by a dense pattern of white dots. The dots are arranged in a way that they appear to be receding or creating a 3D effect, with the dots in the foreground being larger and more distinct than those in the background. The shape is roughly circular but has jagged, organic edges. In the center of this shape, the word "aquamate" is written in a white, lowercase, serif font. A registered trademark symbol (®) is located at the top right of the word.

aquamate[®]

customer care number

As part of Rexair's Customer Care program, each AquaMate receives a Customer Care serial number only after passing Quality Control assurance testing. This serial number provides:

- ✓ Ownership identification for you
- ✓ Warranty identification for your Distributor
- ✓ Assurance of passing Quality Control testing
- ✓ Assurance of "factory-fresh" condition

For future reference, record the serial number in the space provided below. No authentic, new AquaMate should be sold without this number. If the serial number is missing, Rexair makes no claim as to the origin, age, or condition of the unit. If you are unable to locate a serial number on your AquaMate, please contact Rexair's customer service department.



50 W. Big Beaver Road, Suite 350 | Troy, Michigan 48084 | USA
(248) 643-7222 | custserv@rexairllc.com
rainbowsystem.com

Rainbow®, RainbowMate®, RainMate®, AquaMate®, Rexair®, The Power of Water®, Wet Dust Can't Fly® and the configuration of the Rainbow® Cleaning System are registered trademarks of Rexair LLC, Troy, Michigan, United States.

AQUAMATE SERIAL NUMBER



YOUR AUTHORIZED RAINBOW DISTRIBUTOR

NAME	
ADDRESS	
CITY/STATE/POSTAL	
PHONE	
E-MAIL	

Contact your local authorized Rainbow Distributor for advice on caring for your AquaMate, warranty coverage, replacement parts and service information.

important safety instructions



PLEASE READ ALL INSTRUCTIONS BEFORE USING THIS UNIT

When using an electrical appliance, basic precautions should always be followed, including the following:

⚠ WARNING: TO REDUCE RISK OF FIRE, ELECTRICAL SHOCK OR INJURY

1. Do not leave appliance when plugged in. Unplug from outlet when not in use and before servicing.
2. To reduce the risk of electrical shock, use indoors only.
3. To avoid risk of electrical shock and to reduce risk of fire, use only Rainbow cleaning products intended for use with this machine.
4. To avoid risk of electrical shock, use only the hose supplied with the Rainbow for wet pickup operations. See Rainbow owner's manual. Do not modify the electrified plug in any way.
5. The AquaMate contains an electric motor and power cord. To avoid risk of electrical shock, DO NOT immerse the electric cord in water while filling or cleaning the tank.

⚠ IMPORTANT

6. The AquaMate tank is designed to use only clean, cold tap water. To avoid damage to the AquaMate, do not place any of the following into the water tank:
 - Hot water or liquids.
 - Detergents of any kind, including Rainbow products.
 - Commercially available cleaning liquids or compounds.
7. Use only *AquaMate Concentrate Solution* or *Clean Floor Concentrate Solution* in the small side soap tank.
8. Do not use on hardwood, laminate or marble flooring.
9. Ensure the carpet has thoroughly dried before using the Rainbow Power Nozzle to vacuum.
10. Do not use the AquaMate when the clean water tank is empty. This could result in damage to the pump.
11. For further safety instructions, refer to Rainbow Owner's Manual.

SERVICING OF DOUBLE-INSULATED APPLIANCE

In a double-insulated appliance, two systems of insulation are provided instead of grounding. No grounding means is provided on a double-insulated appliance, nor should a means for grounding be added to the appliance. Servicing a double-insulated appliance requires extreme care and knowledge of the system and should be done only by qualified Rainbow service personnel. Replacement parts for a double-insulated appliance must be identical to the parts they replace. A double-insulated appliance is marked with the words "DOUBLE-INSULATION" or "DOUBLE-INSULATED." The Symbol (square within a square) may also be marked on the appliance. Any servicing other than cleaning should be performed by an Authorized Rainbow Distributor or Service Center.



**SAVE THESE
INSTRUCTIONS**

THIS APPLIANCE IS INTENDED FOR HOUSEHOLD USE ONLY
USE THE AQUAMATE ONLY AS DIRECTED IN THIS OWNER'S MANUAL
USE THE AQUAMATE WITH MODEL E2 RAINBOW ONLY

get acquainted with your aquamate®

1. AquaMate
2. AquaMate Tank
3. Stainless Steel Wands*
4. Rainbow Hose*
5. Rainbow*
6. Rainbow Dolly & Water Basin*
7. AquaMate Carpet Cleaner

* Not included

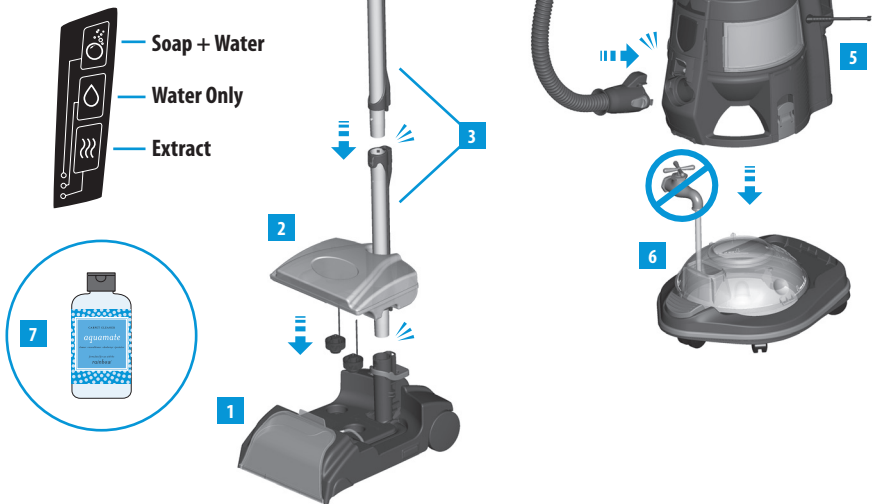

⚠ CAUTION: Do not use the AquaMate on hardwood floors, laminates, marble, Persian and Oriental rugs or other surfaces that may be susceptible to water damage or can be easily scratched.

STORAGE & MAINTENANCE

- The clear plastic lens located on the front of the AquaMate can be easily removed for cleaning between uses.
- The brush roll can be pulled down to allow cleaning between uses.
- To clean water from wands, remove front lens and run Rainbow for 20 seconds.
- A little soap goes a long way! Use no more than one capful of soap in the soap tank, and always fill the remainder of the soap reservoir with clean water.
- Do not store the AquaMate with water or soap in the tank.
- Prior to storing the AquaMate, empty the tank and suck any residual water from the receptacles.
- Always turn the valve "off" and remove the water tank. This eliminates a potential for leakage.
- If the AquaMate is unattended for a short period of time, move the valve to the "off" position.

quick-start guide

1. Prepare the carpet...

- Use the Rainbow and Power Nozzle to vacuum the entire area to be cleaned, making sure there is no remaining debris on the surface.
- Empty and rinse the water basin. Do not refill.

2. Prepare the AquaMate...

- Begin with an empty water basin. Attach the Rainbow and dolly. Attach the hose and wands.
- Insert the bottom wand with male end into the opening located on top of the AquaMate. Press downward until button lock clicks.
- Add one capful of Rainbow AquaMate Concentrate Solution to the AquaMate soap reservoir.
- Fill the remainder of the AquaMate soap reservoir with cool, clean tap water and secure the cap tightly.
- Fill the AquaMate water reservoir with cool, clean tap water and secure the cap tightly.
- Place the AquaMate tank onto the AquaMate until you feel it lock into place.

3. Shampoo...

- Set the AquaMate switch to the SOAP + WATER position. Turn on the Rainbow to HIGH mode.
- Squeeze the pistol trigger grip and apply solution to the carpet using slow forward and backward movements across the floor. Use the handle's trigger lock switch to keep the brush roll fully engaged.



4. Rinse...

- Set the AquaMate switch to the WATER ONLY position.
- Squeeze the pistol trigger grip and rinse the carpet using slow forward and backward movements across the floor. Use the handle's trigger lock switch to keep the brush roll fully engaged.



5. Extract...

- Set the AquaMate switch to the EXTRACT position.
- Extract the remaining water from the carpet using very slow backward movements.
- For extra dry carpet, go over the entire area a second time.
- When finished cleaning, empty and rinse the water basin. Allow to dry.



PRIMING THE AQUAMATE

The AquaMate may require priming, which may take approximately 20 seconds. To reduce priming time, several things can be done:

- Make sure the water tank is fully seated
- Turn the valve to the SOAP + WATER position
- Squeeze and release the handle trigger several times

If the soap reservoir becomes empty while you are operating the AquaMate, and the valve is in the SOAP + WATER position, no water will be dispensed because air is being sucked through the soap reservoir. When operating the AquaMate without soap, always fill the soap reservoir with water to prevent loss of prime.

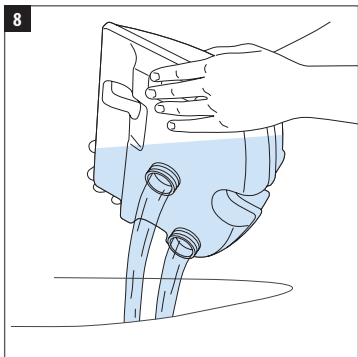
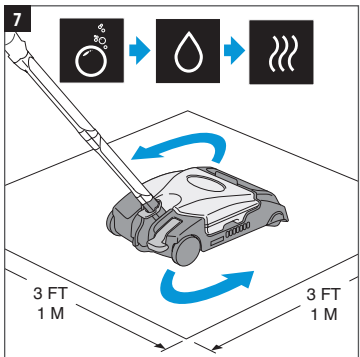
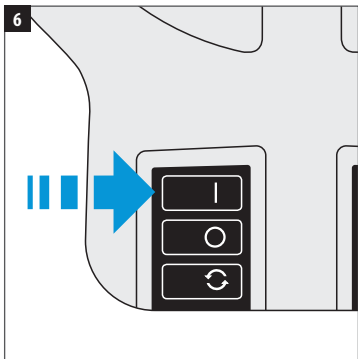
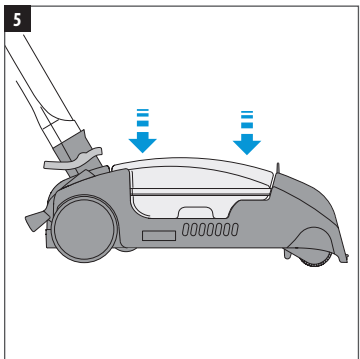
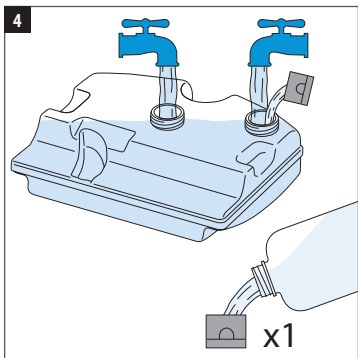
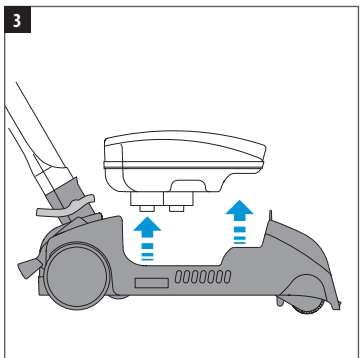
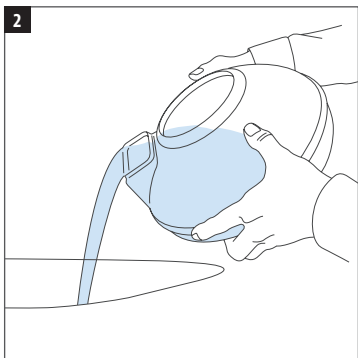
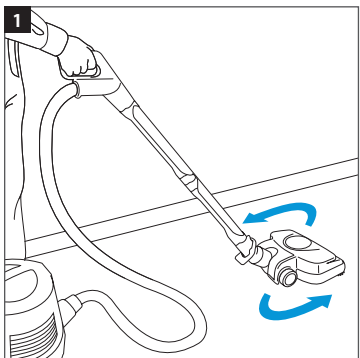

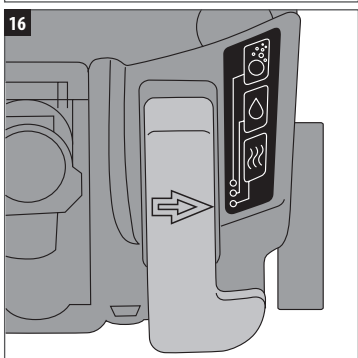
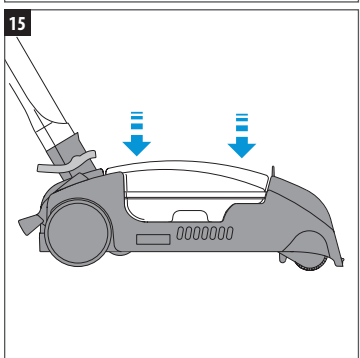
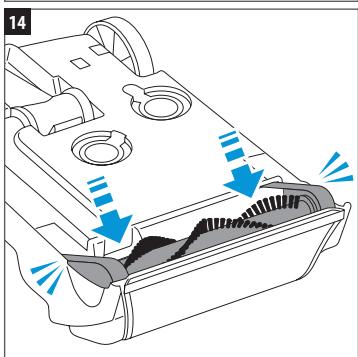
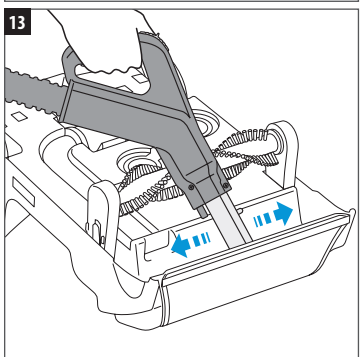
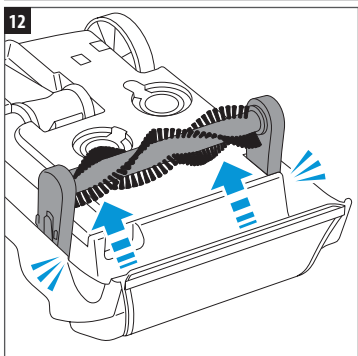
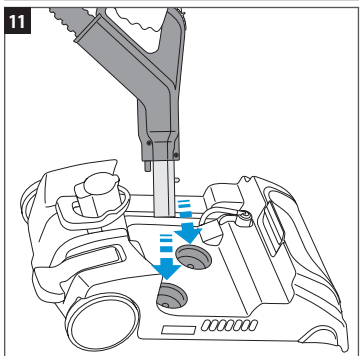
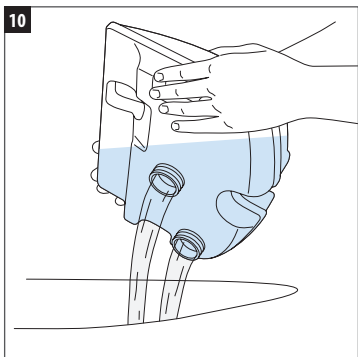
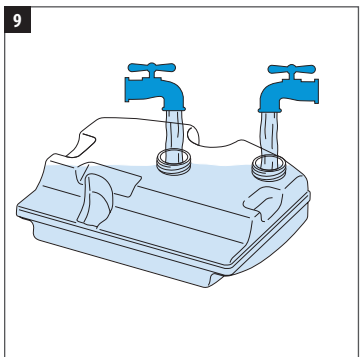

A decorative graphic consisting of numerous white circles of varying sizes, arranged in a pattern that tapers from the right edge towards the center of the page. The circles are scattered across the right half of the blue background.

rainbowsystem.com

REXAIR LLC | TROY, MICHIGAN

© 2011 REXAIR LLC | R14388A-0 | PRINTED IN U.S.A.