

Marley Plumbing & Drainage Solutions Technical Manual GCC



صنع في الإمارات بفخر
Made in UAE *with* Pride

**we
make
life
flow**



01

Marley Brand introduction

Vivasvaan Factory	02
Manufacturing standards & certifications	03
Certification & Recognitions	04



08

Soil & Waste System

ABS Waste Pipes & Fittings Solvent Weld	10
PVC-U Soil Pipes & Fittings Push Fit	12
PVC-U Soil Fittings Solvent Weld	15

18

Underground Drainage Systems

PVC-U Gravity Sewer Drainage Pipes & Fittings	19
Fabricated Solutions	22



25

Soil & Waste Installation Guide

Design Considerations	26
Handling, storage and safety	30
Stack design considerations	32
Joining Guide	40
Pipe Support	43
WC Connectors, Manifold & Traps Guide	46

63

Regional Registrations Approvals & Certifications	63
Project References	64

52

Underground Installation Guide

Design Considerations	53
Pipe Laying	55
Underground Gully Combinations	58
Underground Installation	60
Health and Safety	62

Marley Brand Introduction

Marley, a renowned UK-manufactured brand, is globally recognized for its innovative solutions in plumbing and drainage systems. Now in its 65th year, Marley continues to uphold its legacy of excellence by providing exceptional technical support, alongside extensive product and installation expertise.

Marley Plumbing & Drainage offers a comprehensive range of Unplasticized Polyvinyl Chloride (uPVC) Above-Ground, Soil & Waste, and Underground Drainage Systems. These systems are designed to meet the diverse requirements of commercial, residential, and large-scale developments, as well as smaller construction projects.

As part of the Aliaxis Group of Companies, Marley Plumbing & Drainage benefits from being aligned with one of the world's leading suppliers of construction and building solutions.

Marley's products are designed with sustainability in mind, not only in their manufacturing process but also in their long-term use and performance.

Importantly, the entire Marley range is 100% lead-free, underscoring its commitment to safety and environmental responsibility.





Vivasvaan Industrial Co., in Khalifa Economic Zone Abu Dhabi (KEZAD), has entered into a Strategic Manufacturing License Agreement with Marley Plumbing & Drainage UK, a trusted and well-established brand with a strong presence in the region for over four decades. Marley's uPVC Soil and Waste Piping systems have been installed in numerous landmark projects across the UAE.

Under this agreement, Vivasvaan Industrial Co. will manufacture Marley's uPVC Push-Fit Soil solvent and ABS Waste piping systems in compliance with BS Kitemark standards. These products are intended for residential, commercial, industrial, and public utility applications.

This collaboration strengthens Marley's footprint across the GCC and adds another esteemed partner under the Aliaxis umbrella, further diversifying its regional manufacturing network.

Vivasvaan Industrial Co. is a wholly owned subsidiary of Aquaplex Holding Ltd., a company with over two decades of experience serving the MEP and Construction Supplies industry across the GCC.

Vivasvaan Industrial Co. also signed a Manufacturing License Agreement with Marshall-Tufflex, an 80+ year-old UK-based producer of uPVC Conduit and Cable Management Systems manufactured to BS EN standards, further solidifying its commitment to representing world-class brands in the region.



Manufacturing standards & certifications



British Standard kitemark:
Your guarantee of quality



Cert.No : KM 794709,
KM 794710, KM 794713
KM 836148 & KM 836152

British Standards

A wide range of components featured in this list conform to British Standard Specifications, many items bear the British Standards Institution's Kite Mark symbol, , as indicated throughout this list. The presence of this mark on, or in relation to, a product is an assurance that the goods have been produced under a system of supervision, control and testing, operated during manufacture and including periodical inspection of the manufacturer's works in accordance with the Certification Mark Scheme.

British and European Standards

BS EN 1329-1

Plastics piping systems for soil and waste discharge (low and high temperature) within the building structure – PVCu.

BS EN 1451-1

Plastics piping systems for soil and waste discharge (low and high temperature) within the building structure – polypropylene.

BS EN 1519-1

Plastics piping systems for soil and waste discharge (low and high temperature) within the building structure – polyethylene.

BS 4514

Specification for PVCu soil and ventilating pipes, fittings and accessories.

BS EN 1566-1

Specification for thermoplastics waste pipe and fittings.

BS 5255

Specification for thermoplastics waste pipe and fittings.

BS EN 1455-1

Plastics piping systems for soil and waste (low and high temperature) within the building structure – ABS.

BS 5627

Specification for plastics connectors for use with horizontal outlet vitreous china WC pans.

BS EN 14680

Specification for adhesives for non-pressure thermoplastics pipe systems.

BS EN 681-1

Elastomeric seals. Material requirements for pipe joint seals used in water and drainage applications. Part 1 vulcanised rubber.

BS EN ISO 9001

Quality systems. Model for Quality Assurance in Design, Development, Production, Installation and Servicing.

BS EN ISO 14001

Environmental management systems. Requirements with guidance for use.

Underground Standards

British and European Standards

BS 4660 & BS EN 1401

Thermoplastics ancillary fittings of nominal sizes 110 and 160 for below ground gravity drainage and sewerage.

BS 4962

Specification for plastic pipes and fittings for use as subsoil field drains.

BS EN 14680

Adhesives for non-pressure thermoplastic pipe systems.

BS EN 681-1

Elastomeric seals. Material requirements for pipe joint seals used in water and drainage applications.

BS EN 752

Drain & Sewer Systems outside buildings.

BS EN 1295-1

Structural design of buried pipelines under various conditions of loading. General requirements.

BS EN 13598-2

Plastic piping systems for non-pressure underground drainage and sewerage – Unplasticized poly(vinyl chloride) (PVCU), polypropylene (PP) and polyethylene (PE) Part 2: Specifications for manholes and inspection chambers

BS EN 295

Vitrified clay pipes & fittings and pipe joints for drains and sewers.

BS EN 124

Gully tops and manhole tops for vehicular and pedestrian areas. Design requirements, type testing, marking, quality control.

BS EN 1610

Construction & Testing of Drains & Sewers.

BS EN 13476-3

Plastics piping systems for non-pressure drainage and sewerage, structured wall piping systems with smooth bore and profiled external surface.

Certification & Recognitions



Certificate of Registration

QUALITY MANAGEMENT SYSTEM - ISO 9001:2015

This is to certify that:

Vivasvaan Industrial Co. (SP) LLC
A5, Building No.11, KEZAD
P.O Box 93180
Abu Dhabi
United Arab Emirates

Holds Certificate No:

FM 795178

and operates a Quality Management System which complies with the requirements of ISO 9001:2015 for the following scope:

The Manufacture, Storage and Supply of PVC-U Pipes & Fittings, ABS Pipes & Fittings, PP-R Pipes, PP-R Fibreglass Pipes, PE-RT Pipes and Accessories including its Design

For and on behalf of BSI:

Theuns Kotze, Managing Director Assurance - IMETA

Original Registration Date: 2025-05-12

Effective Date: 2025-05-12

Latest Revision Date: 2025-05-12

Expiry Date: 2028-05-11



Page: 1 of 1

...making excellence a habit.™

This certificate was issued electronically and remains the property of BSI and is bound by the conditions of contract.
An electronic certificate can be authenticated [online](#).
Printed copies can be validated at www.bsigroup.com/ClientDirectory

Information and Contact: BSI, Kitemark Court, Davy Avenue, Knowlhill, Milton Keynes MK5 8PP. Tel: + 44 345 080 9000
BSI Assurance UK Limited, registered in England under number 7805321 at 389 Chiswick High Road, London W4 4AL, UK.
A Member of the BSI Group of Companies.

Certification & Recognitions

bsi.  

Kitemark™ Certificate

This is to certify that: **Vivasvaan Industrial Co. (SP) LLC**
A5, Building No.11, KEZAD
P.O Box 93180
Abu Dhabi
United Arab Emirates

Holds Certificate Number: **KM 794709**

In respect of:
BS EN 1329-1
Plastic piping systems for soil and waste discharge (low and high temperature) within the building structure - unplasticized poly(vinyl chloride) (PVC-U)

This issues the right and licence to use the Kitemark in accordance with the Kitemark Terms and Conditions governing the use of the Kitemark, as may be updated from time to time by BSI Assurance UK Ltd (the "Conditions"). All defined terms in this Certificate shall have the same meaning as in the Conditions.



The use of the Kitemark is authorized in respect of the Product(s) detailed on this Certificate provided at or from the above address.

For and on behalf of BSI: 
Shahn Barhom, Group Product Certification Director

First Issued: 2024-03-01 Effective Date: 2024-03-01
Latest Issue: 2024-03-01 Expiry Date: 2027-02-28

Page: 1 of 3

This certificate has been issued by and remains the property of BSI Assurance UK Ltd, Kitemark Court, Davy Avenue, Knowlhill, Milton Keynes MK5 8PP, United Kingdom and should be returned immediately upon request. To check its validity telephone +44 (0) 345 080 9000. An electronic certificate can be authenticated [online](#).
BSI Assurance UK Limited, registered in England under number 7805321 at 389 Chiswick High Road, London W4 4AL, UK. A member of BSI Group of Companies.

bsi.  

Kitemark™ Certificate

This is to certify that: **Vivasvaan Industrial Co. (SP) LLC**
A5, Building No.11, KEZAD
P.O Box 93180
Abu Dhabi
United Arab Emirates

Holds Certificate Number: **KM 794713**

In respect of:
BS EN 1455-1
Plastic piping systems for soil and waste (low and high temperature) within the building structure - Acrylonitrile-butadiene-styrene (ABS)

This issues the right and licence to use the Kitemark in accordance with the Kitemark Terms and Conditions governing the use of the Kitemark, as may be updated from time to time by BSI Assurance UK Ltd (the "Conditions"). All defined terms in this Certificate shall have the same meaning as in the Conditions.



The use of the Kitemark is authorized in respect of the Product(s) detailed on this Certificate provided at or from the above address.

For and on behalf of BSI: 
Shahn Barhom, Group Product Certification Director

First Issued: 2024-06-28 Effective Date: 2024-06-28
Latest Issue: 2024-06-28 Expiry Date: 2027-02-28

Page: 1 of 2

This certificate has been issued by and remains the property of BSI Assurance UK Ltd, Kitemark Court, Davy Avenue, Knowlhill, Milton Keynes MK5 8PP, United Kingdom and should be returned immediately upon request. To check its validity telephone +44 (0) 345 080 9000. An electronic certificate can be authenticated [online](#).
BSI Assurance UK Limited, registered in England under number 7805321 at 389 Chiswick High Road, London W4 4AL, UK. A member of BSI Group of Companies.

bsi.  

Kitemark™ Certificate

This is to certify that: **Vivasvaan Industrial Co. (SP) LLC**
A5, Building No.11, KEZAD
P.O Box 93180
Abu Dhabi
United Arab Emirates

Holds Certificate Number: **KM 794710**

In respect of:
BS EN 1401-1
Plastics piping systems for non-pressure underground drainage and sewerage - Unplasticized poly(vinyl chloride)(PVC-U)

This issues the right and licence to use the Kitemark in accordance with the Kitemark Terms and Conditions governing the use of the Kitemark, as may be updated from time to time by BSI Assurance UK Ltd (the "Conditions"). All defined terms in this Certificate shall have the same meaning as in the Conditions.

The use of the Kitemark is authorized in respect of the Product(s) detailed on this Certificate provided at or from the above address.

For and on behalf of BSI: 
Shahn Barhom, Group Product Certification Director

First Issued: 2024-12-18 Effective Date: 2024-12-18
Latest Issue: 2024-12-18 Expiry Date: 2027-02-28

Page: 1 of 3

This certificate has been issued by and remains the property of BSI Assurance UK Ltd, Kitemark Court, Davy Avenue, Knowlhill, Milton Keynes MK5 8PP, United Kingdom and should be returned immediately upon request. To check its validity telephone +44 (0) 345 080 9000. An electronic certificate can be authenticated [online](#).
BSI Assurance UK Limited, registered in England under number 7805321 at 389 Chiswick High Road, London W4 4AL, UK. A member of BSI Group of Companies.

Certification & Recognitions

bsi. 

Kitemark™ Certificate

This is to certify that: **Vivasvaan Industrial Co. (SP) LLC**
A5, Building No.11, KEZAD
P.O Box 93180
Abu Dhabi
United Arab Emirates

Holds Certificate Number: **KM 836148**

In respect of:
BS EN 1401-1
Plastics piping systems for non-pressure underground drainage and sewerage - Unplasticized poly(vinyl chloride)(PVC-U)

This issues the right and licence to use the Kitemark in accordance with the Kitemark Terms and Conditions governing the use of the Kitemark, as may be updated from time to time by BSI Assurance UK Ltd (the "Conditions"). All defined terms in this Certificate shall have the same meaning as in the Conditions.

The use of the Kitemark is authorized in respect of the Product(s) detailed on this Certificate provided at or from the above address.

For and on behalf of BSI: **Shahm Barhom, Group Product Certification Director**

First Issued: 2025-11-10 Effective Date: 2025-11-10
Latest Issue: 2025-11-10 Expiry Date: 2027-02-28

Page: 1 of 2

This certificate has been issued by and remains the property of BSI Assurance UK Ltd, Kitemark Court, Davy Avenue, Knowlhill, Milton Keynes MK5 8PP, United Kingdom and should be returned immediately upon request.
To check its validity telephone +44 (0) 345 080 9000. An electronic certificate can be authenticated [online](#).
BSI Assurance UK Limited, registered in England under number 7805321 at Seventh and Eighth Floors, The Acre, 90 Long Acre, London, WC2E 9RA, UK. A member of BSI Group of Companies.

bsi. 

Kitemark™ Certificate

This is to certify that: **Vivasvaan Industrial Co. (SP) LLC**
A5, Building No.11, KEZAD
P.O Box 93180
Abu Dhabi
United Arab Emirates

Holds Certificate Number: **KM 836152**

In respect of:
BS EN 1329-1
Plastic piping systems for soil and waste discharge (low and high temperature) within the building structure - unplasticized poly(vinyl chloride) (PVC-U)

This issues the right and licence to use the Kitemark in accordance with the Kitemark Terms and Conditions governing the use of the Kitemark, as may be updated from time to time by BSI Assurance UK Ltd (the "Conditions"). All defined terms in this Certificate shall have the same meaning as in the Conditions.

The use of the Kitemark is authorized in respect of the Product(s) detailed on this Certificate provided at or from the above address.

For and on behalf of BSI: **Shahm Barhom, Group Product Certification Director**

First Issued: 2025-11-10 Effective Date: 2025-11-10
Latest Issue: 2025-11-10 Expiry Date: 2027-02-28

Page: 1 of 2

This certificate has been issued by and remains the property of BSI Assurance UK Ltd, Kitemark Court, Davy Avenue, Knowlhill, Milton Keynes MK5 8PP, United Kingdom and should be returned immediately upon request.
To check its validity telephone +44 (0) 345 080 9000. An electronic certificate can be authenticated [online](#).
BSI Assurance UK Limited, registered in England under number 7805321 at Seventh and Eighth Floors, The Acre, 90 Long Acre, London, WC2E 9RA, UK. A member of BSI Group of Companies.

bsi. 

Kitemark™ Certificate

No. **KM 841326**

This is to certify that: **Vivasvaan Industrial Co. (SP) LLC**
A5, Building No.11, KEZAD
P.O Box 93180
Abu Dhabi
United Arab Emirates

Holds Certificate Number: **KM 841326**

In respect of:
BS EN 1401-1
Plastics piping systems for non-pressure underground drainage and sewerage - Unplasticized poly(vinyl chloride)(PVC-U)

This issues the right and licence to use the Kitemark in accordance with the Kitemark Terms and Conditions governing the use of the Kitemark, as may be updated from time to time by BSI Assurance UK Ltd (the "Conditions"). All defined terms in this Certificate shall have the same meaning as in the Conditions.

The use of the Kitemark is authorized in respect of the Product(s) detailed on this Certificate provided at or from the above address.

For and on behalf of BSI: **Shahm Barhom, Group Product Certification Director**

First Issued: 2026-02-25 Effective Date: 2026-02-25
Latest Issue: 2026-02-25 Expiry Date: 2027-02-28

Page: 1 of 3

First Issued: 2026-02-25 Effective Date: 2026-02-25
Latest Issue: 2026-02-25 Expiry Date: 2027-02-28

Page: 1 of 3

This certificate has been issued by and remains the property of BSI Assurance UK Ltd, Kitemark Court, Davy Avenue, Knowlhill, Milton Keynes MK5 8PP, United Kingdom and should be returned immediately upon request.
To check its validity telephone +44 (0) 345 080 9000. An electronic certificate can be authenticated [online](#).
BSI Assurance UK Limited, registered in England under number 7805321 at Seventh and Eighth Floors, The Acre, 90 Long Acre, London, WC2E 9RA, UK. A member of BSI Group of Companies.





Soil & Waste Systems

Marley Plumbing & Drainage offers a comprehensive range of soil and waste systems for a complete solution for our customers' needs.

Manufactured to British and European standards, our range of uPVC pipes and fittings covers a wide range of sizes and is designed for use on low-rise, midrise and high-rise projects.

Marley Soil & Waste systems are manufactured with both solvent welding sockets and Push Fit socket to satisfy the various requirements of projects, designers and installers.

Key Product Information

36mm, 43mm and 55/56mm Waste sizes
82mm, 110mm, 160mm and 200mm Soil sizes

Typical Application

36mm, 43mm and 55/56mm Waste sizes
82mm, 110mm, 160mm and 200mm Soil sizes

Features & Benefits

- Push-fit or solvent weld jointing
- Light weight
- Easy to handle on site
- Quick and easy to install, saving time and money
- Provides quick and hygienic removal of sanitary waste water
- All collar bosses are individually pressure tested to ensure joint integrity
- Hole saw locator on all bosses for ease of installation

Soil & Waste Systems

The Waste System is available in solvent weld options in ABS (white & grey) suitable for internal and external applications, lightweight and cost effective for installation, easy to cut, joint and install.

The uPVC Soil System is available with push-fit and solvent weld options incorporating socketed and plain ended pipe. 82, 110 and 160mm pipe support components have been designed specifically to support horizontal or vertical suspended uPVC pipework.



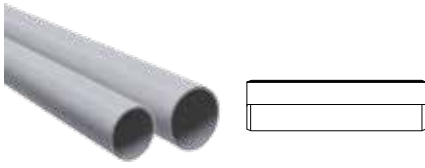

ABS WASTE PIPES- 4Mtr

Code	Length Mtr	Size mm	Size inch	Colour	Qty
EMWAP34	4	36	1 ¼"	Grey/White	♥
EMWAP44	4	43	1 ½"	Grey/White	♥
EMWAP54	4	55	2"	Grey/White	♥

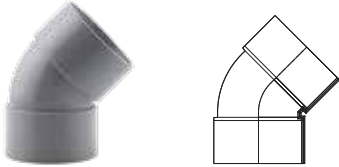

ABS WASTE BEND 45° SS/SS

Code	Size mm	Size inch	Colour	Qty
EMWAB31	36	1 ¼"	Grey/White	
EMWAB41	43	1 ½"	Grey/White	♥
EMWAB51	55	2"	Grey/White	♥

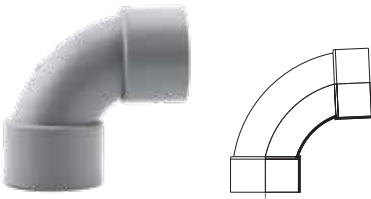

ABS WASTE BEND 87 ½° SS/SS

Code	Size mm	Size inch	Colour	Qty
EMWAB3	36	1 ¼"	Grey/White	♥
EMWAB4	43	1 ½"	Grey/White	♥
EMWAB5	55	2"	Grey/White	♥

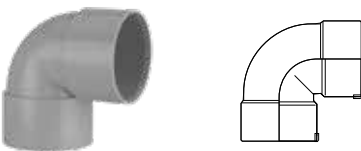

ABS WASTE KNUCKLE BEND 90° SS/SS

Code	Size mm	Size inch	Colour	Qty
EMWAB33	36	1 ¼"	Grey/White	♥
EMWAB43	43	1 ½"	Grey/White	♥

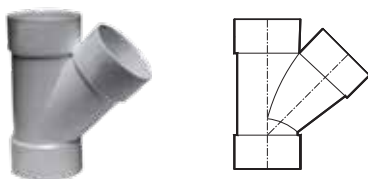

ABS WASTE EQUAL BRANCH 45° SS/SS/SS

Code	Size mm	Size inch	Colour	Qty
EMWAT31	36	1 ¼"	Grey/White	♥
EMWAT41	43	1 ½"	Grey/White	♥
EMWAT51	55	2"	Grey/White	♥

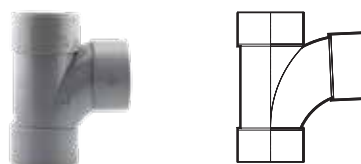

ABS WASTE EQUAL BRANCH 87 ½° SS/SS/SS

Code	Size mm	Size inch	Colour	Qty
EMWAT3	36	1 ¼"	Grey/White	♥
EMWAT4	43	1 ½"	Grey/White	♥
EMWAT5	55	2"	Grey/White	♥

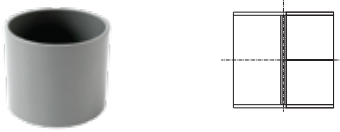

ABS WASTE STRAIGHT SOCKET SS/SS

Code	Size mm	Size inch	Colour	Qty
EMWAC3	36	1 1/4"	Grey/White	♥
EMWAC4	43	1 1/2"	Grey/White	♥
EMWAC5	55	2"	Grey/White	♥



ABS WASTE REDUCER SS/SS

Code	Size mm	Size inch	Colour	Qty
EMWAR43	43x36	1 1/2"x1 1/4"	Grey/White	♥
EMWAR53	55x36	2"x1 1/4"	Grey/White	♥
EMWAR54	55x43	2"x1 1/2"	Grey/White	♥

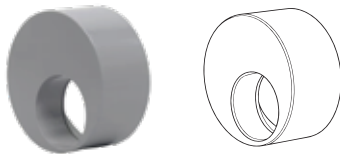

ABS CONDENSATE DRAIN WASTE TO WASTE REDUCER SS/SS

Code	Size mm	Size inch	Colour	Qty
EMRB4048	43x33	1 1/2"x1"	Grey	
EMRB4049	55x33	2"x1"	Grey	



ABS WASTE ACCESS PLUG

Code	Size mm	Size inch	Colour	Qty
EMWAA3	36	1 1/4"	Grey/White	
EMWAA4	43	1 1/2"	Grey/White	
EMWAA5	55	2"	Grey/White	

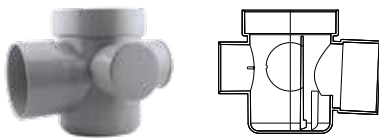

ABS WASTE FLOOR GULLEY TRAP-50mm WATER SEAL

Code	Size mm	Size inch	Colour
EMAB43AS	110X82X55	4"X3"X2"	Grey/White

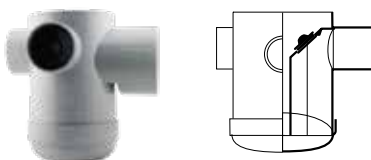

ABS WASTE FLOOR GULLEY TRAP-75mm WATER SEAL

Code	Size mm	Size inch	Colour
EMAFTG43	110X82X55	4"X3"X2"	Grey/White

Standard Colours	
W	G
W: White G: Grey	

Colour code suffix: to indicate the colour you require, add the required colour code to the end of the product code.

Certain SKU's are produced by associated Aliaxis factories, worldwide.

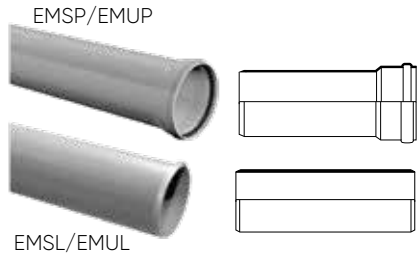

PVC-U SOIL PIPES - 4/6 Mtr

Code	Length Mtr	Size mm	Size inch	Colour	
EMSL304	4	82	3"	Grey	Plain Ended
EMUL306	6	82	3"	Terracotta	Plain Ended
EMUP306	6	82	3"	Terracotta	Socketed End
EMSL404	4	110	4"	Grey	Plain Ended
EMSL604	4	160	6"	Grey	Plain Ended
EMSL806	6	200	8"	Grey	Plain Ended
EMSP806	6	200	8"	Grey	Socketed End
EMSP1006	6	250	10"	Grey	Socketed End
EMSP1206	6	315	12"	Grey	Socketed End

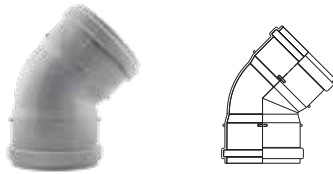

PVC-U SOIL BEND F/F 45°

Code	Size mm	Size inch	Colour	Qty
EMSB355	82	3"	Grey	
EMUB355	82	3"	Terracotta	
EMSB455	110	4"	Grey	
EMSFB655	160	6"	Grey	
EUSFB855	200	8"	Grey	

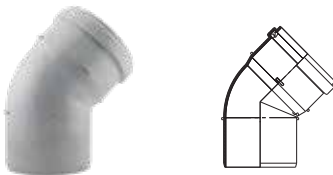

PVC-U SOIL BEND F/M 45°

Code	Size mm	Size inch	Colour	Qty
EMSB35	82	3"	Grey	
EMUB35	82	3"	Terracotta	
EMSB45	110	4"	Grey	
EMSFB65	160	6"	Grey	

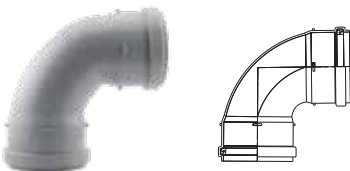

PVC-U SOIL BEND F/F 87 1/2°

Code	Size mm	Size inch	Colour	Qty
EMSB311	82	3"	Grey	
EMUB311	82	3"	Terracotta	
EMSB411	110	4"	Grey	
EMSFB62	160	6"	Grey	
EUSFB82	200	8"	Grey	

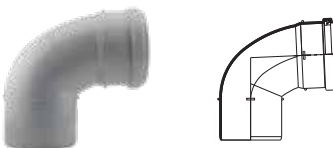

PVC-U SOIL BEND F/M 87 1/2°

Code	Size mm	Size inch	Colour	Qty
EMSB31	82	3"	Grey	
EMUB31	82	3"	Terracotta	
EMSB41	110	4"	Grey	
EMSFB61	160	6"	Grey	



PVC-U SOIL ACCESS BEND F/M 87 1/2°

Code	Size mm	Size inch	Colour	Qty
EMSB32	82	3"	Grey	
EMUB32	82	3"	Terracotta	
EMSB42	110	4"	Grey	

Certain SKU's are produced by associated Aliaxis factories, worldwide.

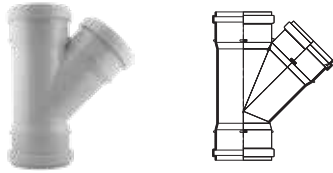

PVC-U SOIL EQUAL BRANCH F/F/F 45°

Code	Size mm	Size inch	Colour	Qty
EMSY367	82	3"	Grey	♥
EMUY366	82	3"	Terracotta	♥
EMSY467	110	4"	Grey	♥
EMSY637	160	6"	Grey	♥
EUSY837	200	8"	Grey	♥

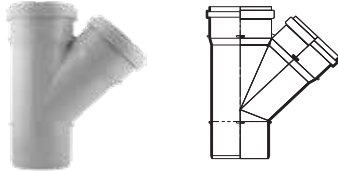

PVC-U SOIL EQUAL BRANCH F/F/M 45°

Code	Size mm	Size inch	Colour	Qty
EMSY36	82	3"	Grey	♥
EMUY36	82	3"	Terracotta	♥
EMSY460	110	4"	Grey	♥
EMSY63	160	6"	Grey	♥

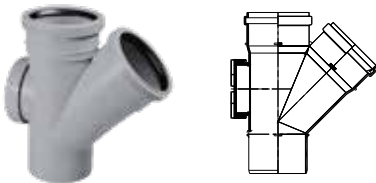

PVC-U SOIL EQUAL ACCESS BRANCH F/F/M 45°

Code	Size mm	Size inch	Colour	Qty
EMSY37	82	3"	Grey	♥
EMUY37	82	3"	Terracotta	♥
EMSY461	110	4"	Grey	♥

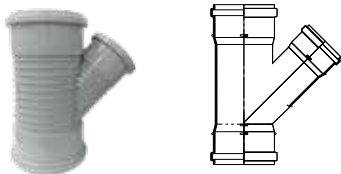

PVC-U SOIL UNEQUAL BRANCH F/F/F 45°

Code	Size mm	Size inch	Colour	Qty
EMSY667	160 X 110	6" X 4"	Grey	♥
EUSY864	200 X 110	8" X 4"	Grey	♥
EUSY867	200 X 160	8" X 6"	Grey	♥

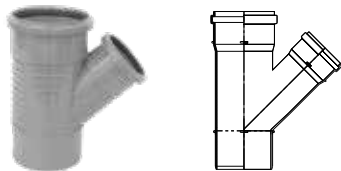

PVC-U SOIL UNEQUAL BRANCH F/F/M 45°

Code	Size mm	Size inch	Colour	Qty
EMSY66	160 X 110	6" X 4"	Grey	♥

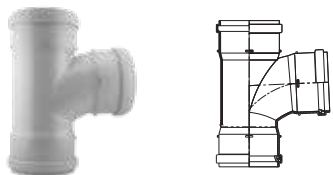

PVC-U SOIL EQUAL BRANCH F/F/F 87 1/2°

Code	Size mm	Size inch	Colour	Qty
EMSY400	110	4"	Grey	♥
EUSMY13C	160	6"	Grey	♥
EUSY800	200	8"	Grey	♥

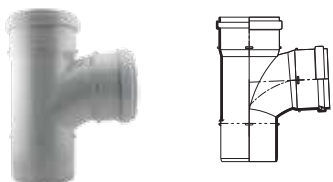

PVC-U SOIL EQUAL BRANCH F/F/M 87 1/2°

Code	Size mm	Size inch	Colour	Qty
EMSY33F	82	3"	Grey	♥
EMUY33F	82	3"	Terracotta	♥
EMSY401	110	4"	Grey	♥
EUSY601	160	6"	Grey	♥

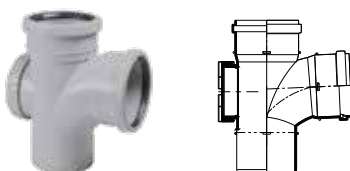



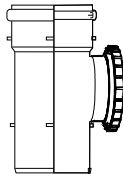

PVC-U SOIL EQUAL ACCESS BRANCH F/F/M 87 1/2°

Code	Size mm	Size inch	Colour	Qty
EMSY402	110	4"	Grey	♥

Certain SKU's are produced by associated Aliaxis factories, worldwide.



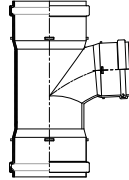

PVC-U SOIL ACCESS PIPE F/M

Code	Size mm	Size inch	Colour	Qty
EMSF31	82	3"	Grey	
EMUF31	82	3"	Terracotta	
EMSF41	110	4"	Grey	
EUSF611	160	6"	Grey	





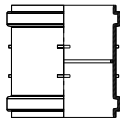

PVC-U SOIL UNEQUAL BRANCH F/F/F 87 1/2°

Code	Size mm	Size inch	Colour	Qty
EUSY647	160X110	6" X 4"	Grey	
EUSY847	200X110	8" X 4"	Grey	
EUSY866	200X160	8" X 6"	Grey	





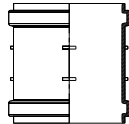

PVC-U SOIL DOUBLE RING SOCKET WITH CENTRAL REGISTER F/F

Code	Size mm	Size inch	Colour	Qty
EMSE306	82	3"	Grey	
EMUE306	82	3"	Terracotta	
EMSE406	110	4"	Grey	
EMSE606	160	6"	Grey	
EUSE806	200	8"	Grey	





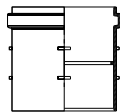

PVC-U SOIL DOUBLE RING REPAIR / SLIP SOCKET F/F

Code	Size mm	Size inch	Colour	Qty
EMSE305	82	3"	Grey	
EMUE305	82	3"	Terracotta	
EMSE405	110	4"	Grey	
EMSE605	160	6"	Grey	
EUSE805	200	8"	Grey	



PVC-U SOIL SINGLE RING SOCKET WITH CENTRAL REGISTER F/SS

Code	Size mm	Size inch	Colour	Qty
EMSE300	82	3"	Grey	
EMUE300	82	3"	Terracotta	
EMSE400	110	4"	Grey	
EMSE600	160	6"	Grey	
0632082	200	8"	Grey	

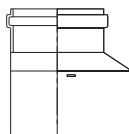

PVC-U SOIL LEVEL INVERT REDUCER F/M

Code	Size mm	Size inch	Colour	Qty
EMSRM304	110x82	4" X 3"	Grey	
EMURM304	110x82	4" X 3"	Terracotta	
EMSRM604	160x110	6" X 4"	Grey	
EUSRM804	200X110	8" X 4"	Grey	
EUSRM806	200x160	8" X 6"	Grey	

Certain SKU's are produced by associated Aliaxis factories, worldwide.

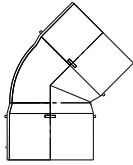

PVC-U SOIL DOUBLE SOCKETED BEND SS/SS 45°

Code	Size mm	Size inch	Colour	Qty
EMSBS35	82	3"	Grey	♥
EMSBS45	110	4"	Grey	♥
EMSBS65	160	6"	Grey	
EM0702002	200	8"	Grey	

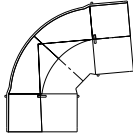

PVC-U SOIL DOUBLE SOCKETED BEND SS/SS 87 1/2°

Code	Size mm	Size inch	Colour	Qty
EMSBS31	82	3"	Grey	♥
EMSBS42	110	4"	Grey	♥
EUSBS62	160	6"	Grey	
EUSBS82	200	8"	Grey	

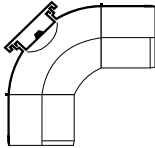

PVC-U SOIL DOUBLE SOCKETED ACCESS BEND SS/SS 87 1/2°

Code	Size mm	Size inch	Colour	Qty
EMSBS310	82	3"	Grey	♥
EMSBS420	110	4"	Grey	♥

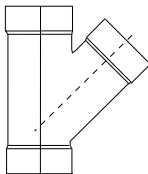

PVC-U SOIL EQUAL BRANCH SS/SS/SS 45°

Code	Size mm	Size inch	Colour	Qty
EMSYS366	82	3"	Grey	
EMSYS466	110	4"	Grey	
EMSYS666	160	6"	Grey	
1442002	200	8"	Grey	

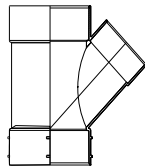

PVC-U SOIL UNEQUAL BRANCH SS/SS/SS 45°

Code	Size mm	Size inch	Colour	Qty
EMSYS644	160X110	6" X 4"	Grey	♥
0312002	200X160	8" X 6"	Grey	

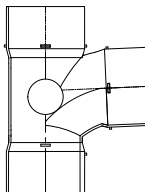

PVC-U SOIL EQUAL BRANCH SS/SS/SS 87 1/2°

Code	Size mm	Size inch	Colour	Qty
EMSYS301	82	3"	Grey	♥
EMSYS401	110	4"	Grey	♥
EUSYS601	160	6"	Grey	

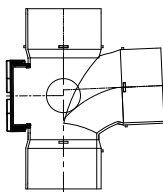

PVC-U SOIL EQUAL ACCESS BRANCH SS/SS/SS 87 1/2°

Code	Size mm	Size inch	Colour	Qty
EMSYS310	82	3"	Grey	♥
EMSYS420	110	4"	Grey	♥

Certain SKU's are produced by associated Aliaxis factories, worldwide.

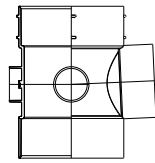

PVC-U SOIL UNEQUAL BRANCH SS/SS/SS 87 1/2°

Code	Size mm	Size inch	Colour	Qty
EUSYS664	160X110	6" X 4"	Grey	

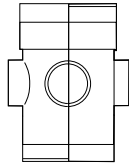

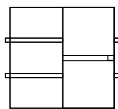

PVC-U SOIL 4-WAY BOSS PIPE RAISER SOCKET SS/M

Code	Size mm	Size inch	Colour	Qty
EMSW405	110	4"	Grey	



PVC-U SOIL DOUBLE SOLVENT SOCKET SS/SS

Code	Size mm	Size inch	Colour	Qty
EMSES301	82	3"	Grey	
EMSES401	110	4"	Grey	
EUSES601	160	6"	Grey	
EUSES805	200	8"	Grey	

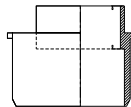

PVC-U SOIL ECCENTRIC REDUCER SS/M

Code	Size mm	Size inch	Colour	Qty
EMSRM30	82X56	3" X 2"	Grey	
EMSR304	110X82	4" X 3"	Grey	
EMSR604	160X110	6" X 4"	Grey	
EUSR806	200X160	8" X 6"	Grey	

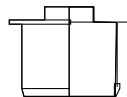

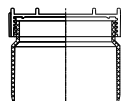

PVC-U SOIL CONCENTRIC REDUCER SS/M

Code	Size mm	Size inch	Colour	Qty
EMSE41	110X56	4" X 2"	Grey	



PVC-U SOIL SCREWED ACCESS CAP SS

Code	Size mm	Size inch	Colour	Qty
EMSE30	82	3"	Grey	
EMUE30	82	3"	Terracotta	
EMSE40	110	4"	Grey	
EMSE62	160	6"	Grey	
EUSE82	200	8"	Grey	

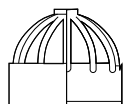

PVC-U SOIL VENT COWL

Code	Size mm	Size inch	Colour	Qty
EMSV321	82	3"	Grey	
EMSV42	110	4"	Grey	
EMSV62	160	6"	Grey	

Certain SKU's are produced by associated Aliaxis factories, worldwide.

Underground Drainage Systems

- Solid Wall Drainage Systems
- 82,110,160 & 200mm sizes
- Larger sizes available from related Aliaxis Brands

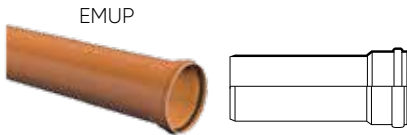

PVC-U U/G DRAINAGE & SEWERAGE PIPES -6Mtr

Code	Length Mtr	Size mm	Size inch	Colour	Qty
EMUP406	6	110	4"	Terracotta	♥
EMUP606SN2	6	160	6"	Terracotta	♥
EMUP606SN4	6	160	6"	Terracotta	♥
EMUP806	6	200	8"	Terracotta	♥
EMUP1006	6	250	10"	Terracotta	♥
EMUP1206	6	315	12"	Terracotta	♥

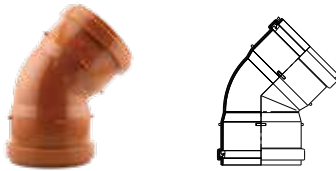

PVC-U U/G DRAINAGE BEND F/F 45°

Code	Size mm	Size inch	Colour	Qty
EMUB455	110	4"	Terracotta	♥
EMUMB14C	160	6"	Terracotta	
EUUB855	200	8"	Terracotta	

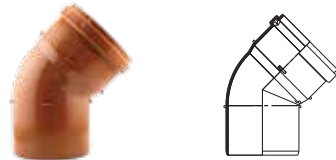

PVC-U U/G DRAINAGE BEND F/M 45°

Code	Size mm	Size inch	Colour	Qty
EMUB45	110	4"	Terracotta	♥
EMUFB65	160	6"	Terracotta	♥

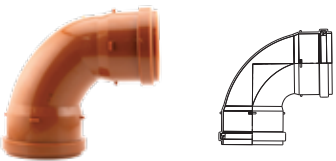

PVC-U U/G DRAINAGE BEND F/F 87 1/2°

Code	Size mm	Size inch	Colour	Qty
EMUB411	110	4"	Terracotta	♥
EMUMB19C	160	6"	Terracotta	
EUUB811	200	8"	Terracotta	

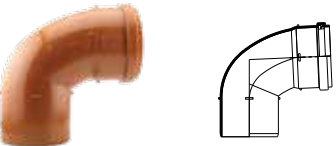

PVC-U U/G DRAINAGE BEND F/M 87 1/2°

Code	Size mm	Size inch	Colour	Qty
EMUB41	110	4"	Terracotta	♥
EMUFB61	160	6"	Terracotta	♥

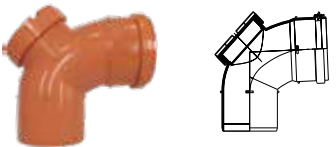

PVC-U U/G DRAINAGE ACCESS BEND F/M 87 1/2°

Code	Size mm	Size inch	Colour	Qty
EMUB42	110	4"	Terracotta	♥

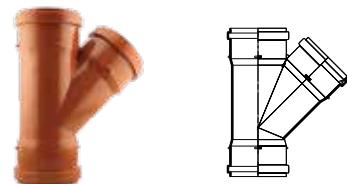

PVC-U U/G DRAINAGE EQUAL BRANCH F/F/F 45°

Code	Size mm	Size inch	Colour	Qty
EMUY466	110	4"	Terracotta	♥
EMUMY11C	160	6"	Terracotta	
EUUY866	200	8"	Terracotta	

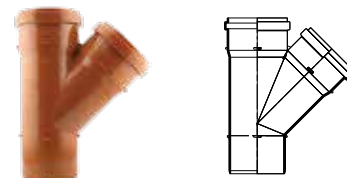

PVC-U U/G DRAINAGE EQUAL BRANCH F/F/M 45°

Code	Size mm	Size inch	Colour	Qty
EMUY46	110	4"	Terracotta	♥
EMUY63	160	6"	Terracotta	♥

Certain SKU's are produced by associated Aliaxis factories, worldwide.

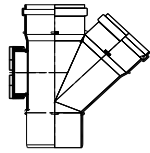

**PVC-U U/G DRAINAGE EQUAL ACCESS
BRANCH F/F/M 45°**

Code	Size mm	Size inch	Colour	Qty
EMUY461	110	4"	Terracotta	♥

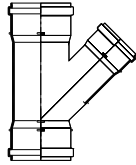

PVC-U U/G DRAINAGE UNEQUAL BRANCH F/F/F 45°

Code	Size mm	Size inch	Colour	Qty
EMUY666	160X110	6" X 4"	Terracotta	♥
EUJY867	200X160	8" X 6"	Terracotta	

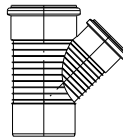

PVC-U U/G DRAINAGE UNEQUAL BRANCH F/F/M 45°

Code	Size mm	Size inch	Colour	Qty
EMUY66	160X110	6" X 4"	Terracotta	♥

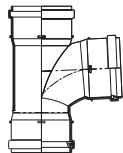

PVC-U U/G DRAINAGE EQUAL BRANCH F/F/F 87 1/2°

Code	Size mm	Size inch	Colour	Qty
EMUY400	110	4"	Terracotta	♥
EUJMY13C	160	6"	Terracotta	
EUJY800	200	8"	Terracotta	

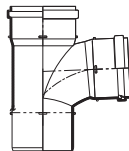

PVC-U U/G DRAINAGE EQUAL BRANCH F/F/M 87 1/2°

Code	Size mm	Size inch	Colour	Qty
EMUY401	110	4"	Terracotta	♥
EUJY601	160	6"	Terracotta	

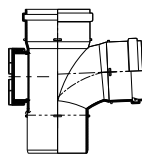

**PVC-U U/G DRAINAGE EQUAL ACCESS
BRANCH F/F/M 87 1/2°**

Code	Size mm	Size inch	Colour	Qty
EMUY402	110	4"	Terracotta	♥

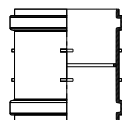

**PVC-U U/G DRAINAGE DOUBLE RING
SOCKET WITH CENTRAL REGISTER F/F**

Code	Size mm	Size inch	Colour	Qty
EMUE406	110	4"	Terracotta	♥
EMUME15C	160	6"	Terracotta	♥
EUJUE806	200	8"	Terracotta	

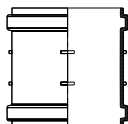

**PVC-U U/G DRAINAGE DOUBLE RING
REPAIR SOCKET F/F**

Code	Size mm	Size inch	Colour	Qty
EMUE405	110	4"	Terracotta	♥
EMUME16C	160	6"	Terracotta	♥
EUJUE805	200	8"	Terracotta	

Certain SKU's are produced by associated Aliaxis factories, worldwide.

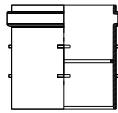

PVC-U U/G DRAINAGE SINGLE RING SOCKET F/SS

Code	Size mm	Size inch	Colour	Qty
EMUE400	110	4"	Terracotta	♥
EMUE600	160	6"	Terracotta	♥

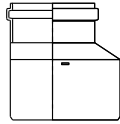

PVC-U U/G DRAINAGE LEVEL INVERT REDUCER F/M

Code	Size mm	Size inch	Colour	Qty
EMURM304	110X82	4" X 3"	Terracotta	♥
EMURM604	160X110	6" X 4"	Terracotta	♥
EUURM806	200X160	8" X 6"	Terracotta	

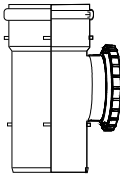

PVC-U U/G DRAINAGE ACCESS PIPE F/M

Code	Size mm	Size inch	Colour	Qty
EUUF41	110	4"	Terracotta	
EUUF61	160	6"	Terracotta	
EUUF811	200	8"	Terracotta	

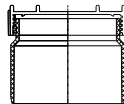

PVC-U U/G DRAINAGE SCREWED ACCESS CAP

Code	Size mm	Size inch	Colour	Qty
EMUE40	110	4"	Terracotta	
EUUE62	160	6"	Terracotta	

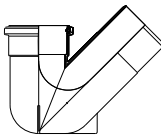

PVC-U U/G DRAINAGE GULLY P-TRAP BASE 45°

Code	Size mm	Size inch	Colour	Qty
EMUG44	110	4"	Terracotta	♥

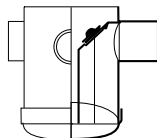

PVC-U U/G DRAINAGE GULLY TRAP-75mm WATER SEAL

Code	Size mm	Size inch	Colour	Qty
EMUG43AS	110X82X56	4"X3"X2"	Terracotta	



PVC-U U/G DRAINAGE BOTTLE GULLY TRAP SEALED ACCESS

Code	Size mm	Size inch	Colour	Qty
EUDS41	110	4"	Terracotta	

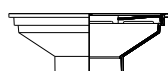

PVC-U U/G DRAINAGE RECTANGULAR HOPPER WITH GRID

Code	Size mm	Size inch	Colour	Qty
EMUG47	110	4"	Terracotta	

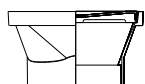

PVC-U U/G DRAINAGE GRATING ASSEMBLY WITH GRID

Code	Size mm	Size inch	Colour	Qty
EMUG45	110	4"	Terracotta	

Certain SKU's are produced by associated Aliaxis factories, worldwide.



PVC-U CATCH BASIN WITH GRP PERFORATED BASKET

DIA. 250- 315mm



Scan to view more Technical information.



PVC-U DRAINAGE DRY MANHOLE

DIA. 110- 160mm



Scan to view more Technical information.



PVC-U DRY GULLY TRAP

DIA. 110- 315mm



Scan to view more Technical information.



PVC-U GULLY TRAP (GRATING) WITH ACCESS

DIA. 110- 315mm



Scan to view more Technical information.



PVC-U SAND TRAP BASKET



Scan to view more Technical information.



PVC-U GREASE TRAP TYPE A/B



Scan to view more Technical information.





PVC-U GREASE TRAP TYPE C/D



Scan to view more
Technical information.



PVC-U PUDDLE FLANGE

DIA. 43- 315mm



Scan to view more
Technical information.



PVC-U P TRAP

DIA. 110- 160mm



Scan to view more
Technical information.



PVC-U PERFORATED PIPE

DIA. 110- 315mm



Scan to view more
Technical information.



**PVC-U DRAIN SLOTTED
PIPE-HALF ROUND**

DIA. 110- 315mm



Scan to view more
Technical information.



PVC-U END CAP

DIA. 56 - 315mm



Scan to view more
Technical information.





PVC-U CORNER TEE

DIA. 82- 160mm



Scan to view more
Technical information.



PVC-U DOUBLE TEE BRANCH

DIA. 82 - 200mm



Scan to view more
Technical information.



PVC-U DOUBLE Y BRANCH

DIA. 82 - 200 mm



Scan to view more
Technical information.



PVC-U LONG RADIUS BEND

DIA. 82 - 110mm



Scan to view more
Technical information.



PVC-U BELL MOUTH SOCKET

DIA. 110- 160mm



Scan to view more
Technical information.



PVC-U INTERCEPTORS

DIA. 110- 160mm



Scan to view more
Technical information.



Soil & Waste Installation Guide

- Design considerations
- Stack design considerations
- Jointing guide
- Pipe Support
- Connection systems guide
- Handling, storage & safety

Soil & Waste – Design Considerations

All sanitary pipework systems should be designed to satisfy the following regulations and standards where applicable.

The Building Regulations 2010: Approved Document H, Section 1.

The Building Standards Technical Handbook (Scotland) 2010: Part M.

The Building Regulations (Northern Ireland) 2000, Technical Handbook N.

BS EN 12056: 2000, Parts 1 to 5.

Regular consultation is essential between Architects and Plumbing Engineers throughout the building design stage as the careful arrangement of kitchen and bathroom appliances will simplify the final sanitary pipework layout. This will help to ensure that an efficient sanitary pipework system is

installed at minimum cost.

The design information provided in this catalogue is endorsed in the above publications and while every effort has been made to ensure accuracy, no responsibility can be accepted for errors or omissions. For detailed guidance please consult the relevant documents referred to above.

Building Information Modelling (BIM)

Marley PVCu soil systems are now available to download in Autodesk Revit digital format from the BIM library at Bimstore:

<https://www.bimstore.co/manufacturers/marley-plumbing-and-drainage>

AutoCAD format are also available.

Material and manufacture

Marley Plumbing & Drainage pipes and fittings for sanitary pipework systems are manufactured from different plastics materials including uPVC, and ABS.

The table below details the important dimensions and weights of each of the systems together with the relevant British and European Standards we manufacture to. All pipes are manufactured using a continuous extrusion process and fittings are produced by high-pressure injection moulding.

Table 1: Pipe dimensions and weights

Pipe Material Standard	BS Nominal Size (mm/inch)	Mean Outside Diameter (mm)		Wall Thickness (mm) Min	Weight kg/metre
		Min	Max		
Soil PVCu					
Pipe: BS 4514	82	82.4	82.0	3.0	1.30
Pipe: BS EN 1329	110	110.0	110.3	3.20	1.70
	160	160.0	160.4	3.20	2.50
Waste PVC-c					
Fittings: BS 5255	36/1¼	36.15	36.5	1.80	0.33
Pipe: BS EN 1566	40/1½	42.75	43.1	1.90	0.41
	50/2	55.75	56.1	2.00	0.57
Waste ABS					
Pipe and fittings:	32/1¼	36.15	36.5	1.80	0.20
	43/1½	42.75	43.1	1.90	0.26
BS EN 1455	50/2	55.75	56.1	2.00	0.35
Waste Polypropylene					
Pipe: BS EN 1451	32/1¼	34.45	34.8	1.80	0.21
	40/1½	40.85	41.2	1.90	0.26
Overflow PVCu					
	21.5/¾	21.55	21.70	1.10	0.11

Chemical and temperature resistance

Most plastics used for sanitary pipework are highly resistant to those chemicals normally found in domestic waste water and sewerage systems. For applications where chemical discharges are likely to occur, Vulcathene product range is more ideal.

Generally the maximum working temperature of Marley PVCu when subjected to continuous flow is 70°C and 75°C respectively. Higher intermittent discharges of up to 95°C may be accommodated by PVCu provided the period of discharge does not exceed one minute duration.

Alternatively, reference can be made to ISO publications TR10358 & TR7620 which provide comprehensive information on chemical and temperature resistance of plastics and rubber materials.

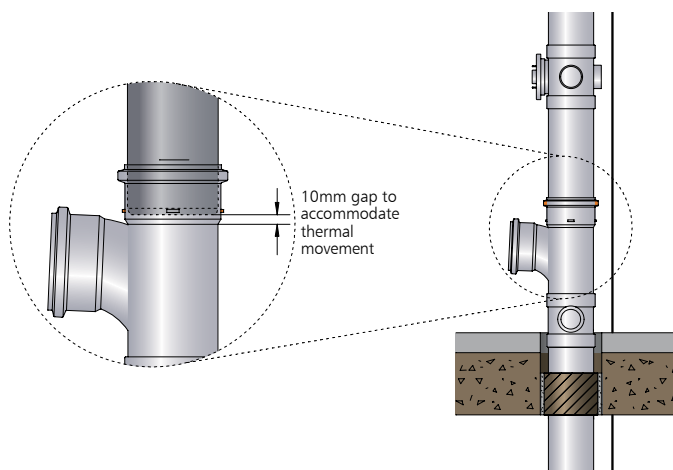

Fig 1.

Typical Ø110mm **soil pipe** branch with push-fit seal joint on each floor to allow for thermal expansion

Thermal Movement

The coefficient of linear expansion for PVCu is 0.06mm/m/°C. As a result a 3m length of pipe will increase in length by approximately 3.6mm when subjected to a 20°C temperature variation.

Therefore, it is important to ensure that any movement is controlled and push-fit joints are installed to accommodate any expansion that may occur due to increases in ambient temperature or hot water discharges.

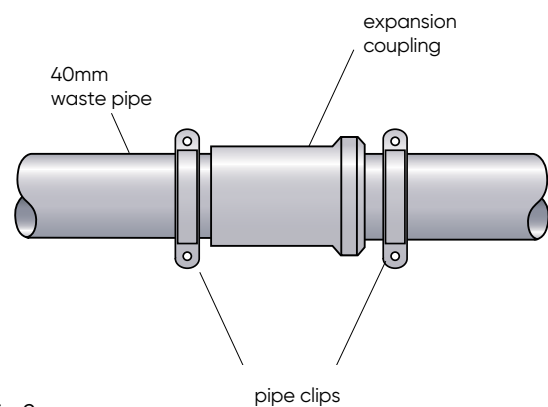

Fig 2.

Ø40mm **waste pipe** expansion coupler. Needed where pipe length exceeds 1.8m between fixed points.

Soil & Waste Design Considerations

Calculation of Flowrate

Waste water flowrate Q_{ww} is the expected flowrate of waste water in a part or in the whole drainage system where only domestic sanitary appliances are connected to the system.

$$Q_{ww} = K \sqrt{\Sigma DU}$$

Where: Q_{ww} = waste water flowrate (l/s)

K = Frequency factor (table 2)

ΣDU = Sum of discharge units (table 1)

Table 1

Appliance	Discharge Units (DU), l/s
WC, 6L cistern (1.2 - 1.7L/s)	1.7
Wash basin	0.3
Bath	1.3
Shower tray (no plug)	0.4
Kitchen sink	1.3
Urinal (cistern flush) per person	0.2
Bidet	0.3
Dishwasher, domestic	0.2
Washing machine, up to 6 kg	0.6
Washing machine, up to 12 kg	1.2

Table 2

Frequency of Use Factors

Intermittent use, e.g. House, flat, offices	0.5
Frequent use, e.g. Hotel, school, hospital	0.7
Congested use, e.g. Public use	1.0
Special use, e.g. Laboratory	1.2

Vertical Soil Stack Capacity

Primary Ventilated Stack Option	DU
82mm Discharge Stack (no WC's)	2.6
110mm Discharge Stack	5.2
160mm Discharge Stack	12.4

Secondary Ventilated Stack Option	DU
82mm Stack & 50mm 2nd Vent (no WC's)	3.4
110mm Stack & 50mm 2nd Vent	7.3
160mm Stack & 82mm 2nd Vent	18.3



Fire Protection

The Building Regulations 1991 (as amended) require that a building shall be sub-divided into compartments where necessary to inhibit the spread of fire. Plastics pipework is permitted to penetrate separating walls, compartment walls and floors provided the appropriate measures are taken to prevent the spread of fire in accordance with Part B of the Approved Document (2010).

To comply with this, pipes must be enclosed within a fire resistant enclosure which extends from floor to ceiling within each storey. The enclosure must have a class 'O' internal surface and have each side formed by a separating wall, external wall or by casing. Any casing must have a minimum 1/2 hour fire resistance and penetrations of the duct must be limited to 160mm vertical and 110mm horizontal.

Where longer periods of fire resistance are required, fire collars or pipe wraps can be fitted.

Tests carried out at FIRTO on a variety of typical sanitary pipework arrangements proved that it was possible to achieve up to 1 1/2 hour fire rating through a compartment floor without a fire collar or pipe wrap where the stack was terminated by an air admittance valve.

Various other arrangements were also tested and achieved a minimum of 2 hours integrity.

The construction illustrated below achieved a 1 1/2 hour fire resistance rating without the need for a fire resistance enclosure. The enclosure is necessary to achieve a 2 hour rating.

Please contact a fire protection specialist to ensure stack protection against any possible fire.

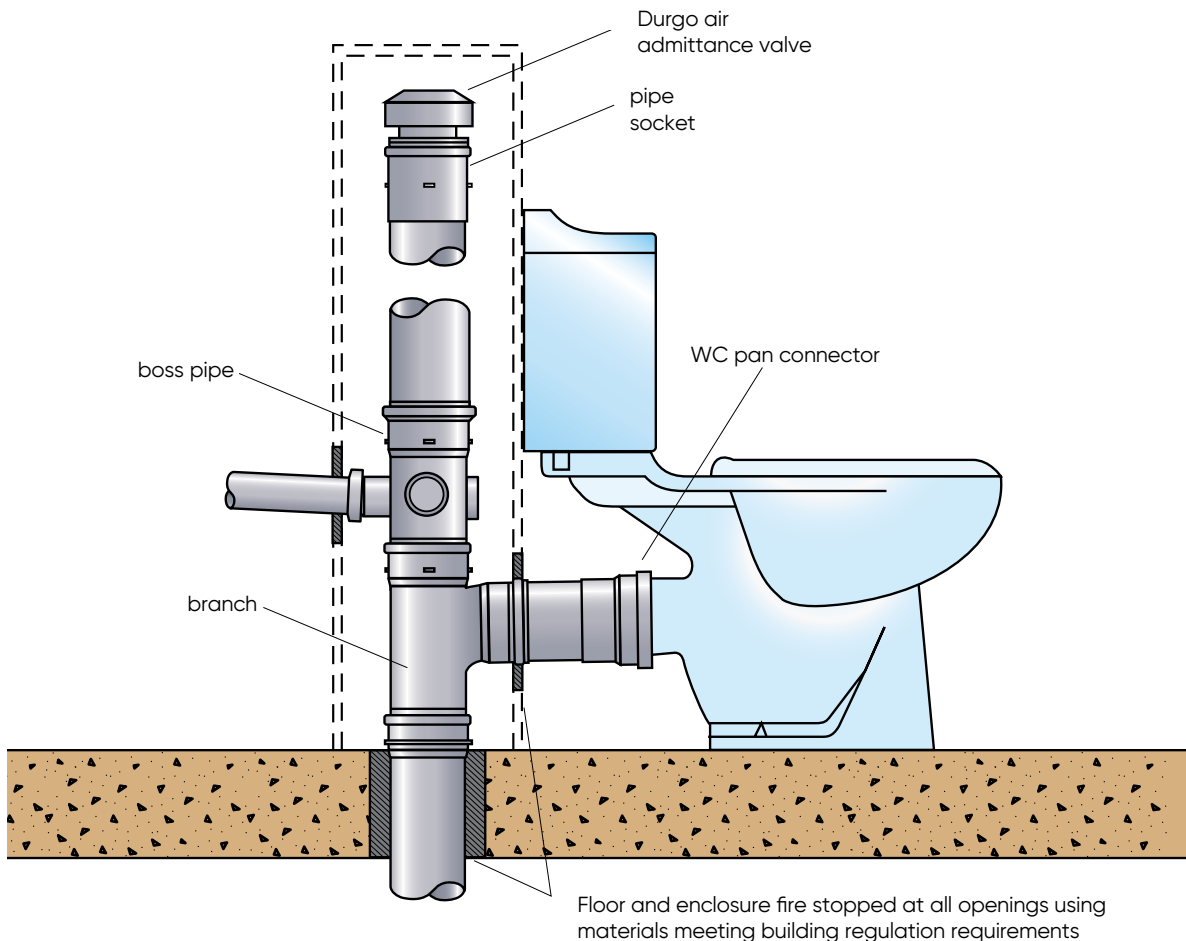

Soil & Waste – Handling, storage and safety

Handling

PVCu pipes are strong, though lightweight and therefore very easily handled. However, reasonable care should be exercised while handling, particularly in extremely cold conditions. Pipes should preferably be loaded and unloaded by hand but if mechanical handling is used, protected slings are recommended.

Inspection and testing

Inspection and testing should be carried out in accordance with BS EN 12056: 2000 and Building Regulations noting especially the details given in respect of air testing and the fact that smoke testing of plastics pipework should be avoided as the materials can be adversely affected.

Maintenance

Provided that the system is designed and installed correctly, no maintenance will be required. If blockage does occur, use only flexible or roller

type rods. Pointed or bearing type metal fittings are not recommended. Tests have been carried out on PVCu pipes and fittings using equipment from specialist drain cleaning contractors and their standard equipment is suitable.

Air test

The installation should be capable of withstanding an air test of positive pressure of at least 38mm water gauge for at least 3 minutes. During this time every trap should maintain a water seal of at least 25mm.

Safety

The relevant regulations are outlined in the Health and Safety At Work Act 1974 and The Construction (Design and Management) Regulations 1994 and should be followed. Hazard sheets, dealing with the correct storage, use, and any hazards of working with solvent cement, silicone lubricant and fire protection products are available from Marley Plumbing & Drainage.



Storage

Pipes should be stacked on a reasonably flat, level surface on timber battens not less than 75mm wide spaced at a maximum of 1m centers. Side support should also be provided at intervals of not more than 1.5m.

Different size pipes should be stacked separately. However, where this is not possible, larger diameter pipes should be placed at the bottom.

Spigot and socket pipes should be stacked separately. However, where this is not possible, larger diameter pipes should be stacked with sockets at alternate ends protruding to ensure pipes are evenly supported along their length.

Pipes should not be stacked more than 7 high and when stored in the open for long periods, or exposed to strong sunlight, they should be covered with an opaque sheet.

Fittings supplied in cardboard boxes should be stored under cover and kept packed until required. Solvent cement should be stored in a cool place out of direct sunlight and away from any heat source.

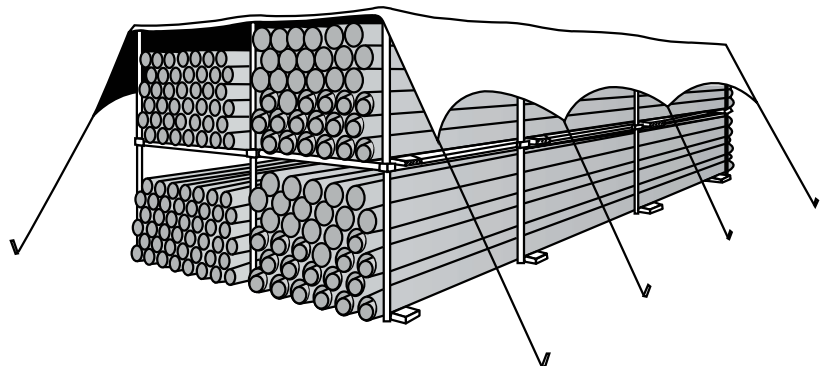
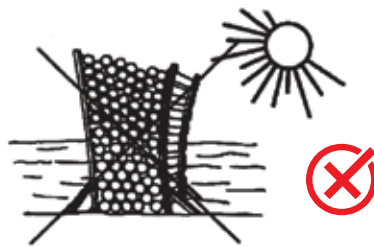

Soil & Waste – Stack Design Considerations

Typical UK design - single soil & vent pipe (SVP)

- Ø110mm vertical soil stack with direct connections for:
 - Ø110mm soil pipe branch for WC
 - Ø32 waste pipe for washbasin
 - Ø40mm waste pipe bath and ground floor
 - Ø40mm waste pipe for kitchen sink
- Vented to atmosphere through roof
- Ø110mm connection to underground drainage system
- Design to British Standard BS 12056

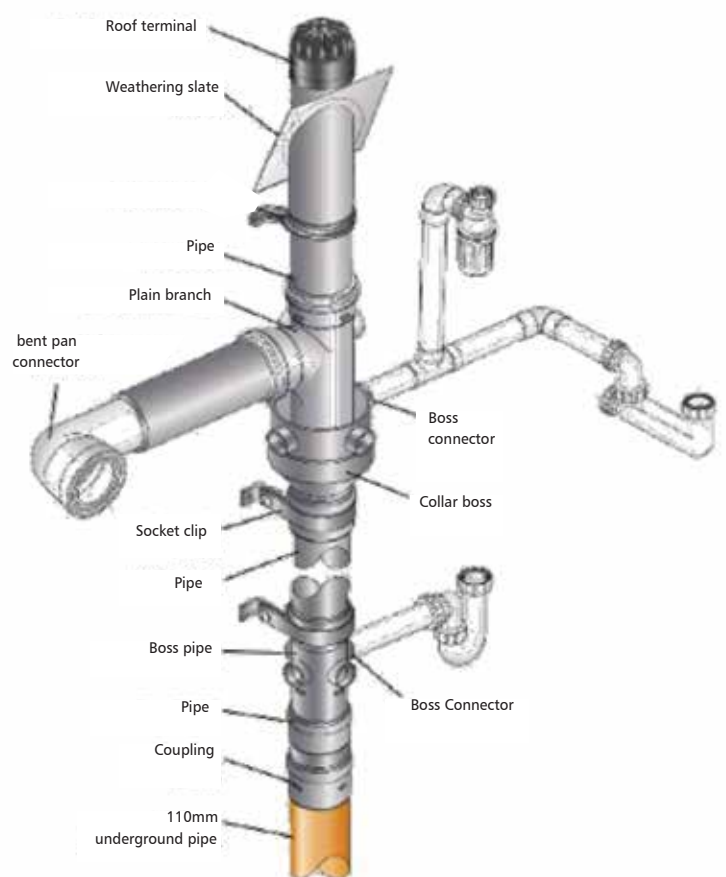

Two pipe soil and vent system

- Separate Ø110mm vertical soil pipe for WC pan branch connection
- Separate Ø110mm vertical soil pipe for Ø82mm branch connection waste pipe to bathroom and kitchen via trapped floor gully
- Vented to atmosphere through roof
- Clean-outs used on horizontal pipe runs and each floor level
- Design common to Asian markets

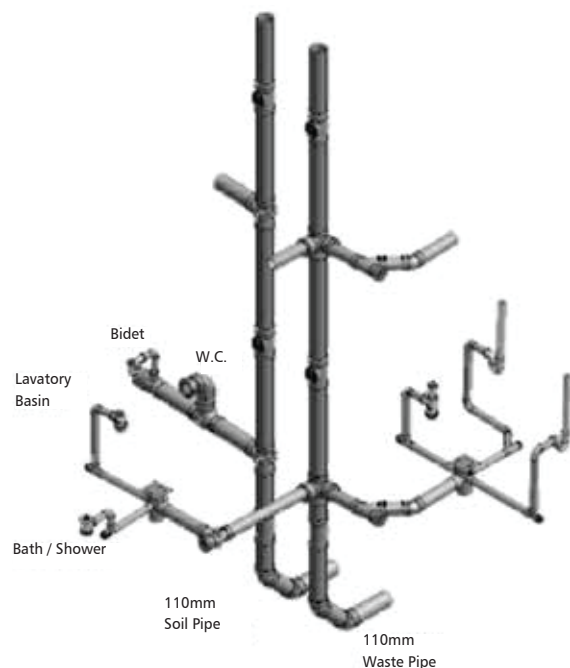

Typical Middle East soil & waste layout

Shown below is a typical bathroom installation using Marley Plumbing & Drainage products. The installation consists of a separate soil and waste stack, which may not be required in all applications where one stack will suffice.

This diagram shows a range of ways of connecting waste to a soil stack and the typical connections to appliances.

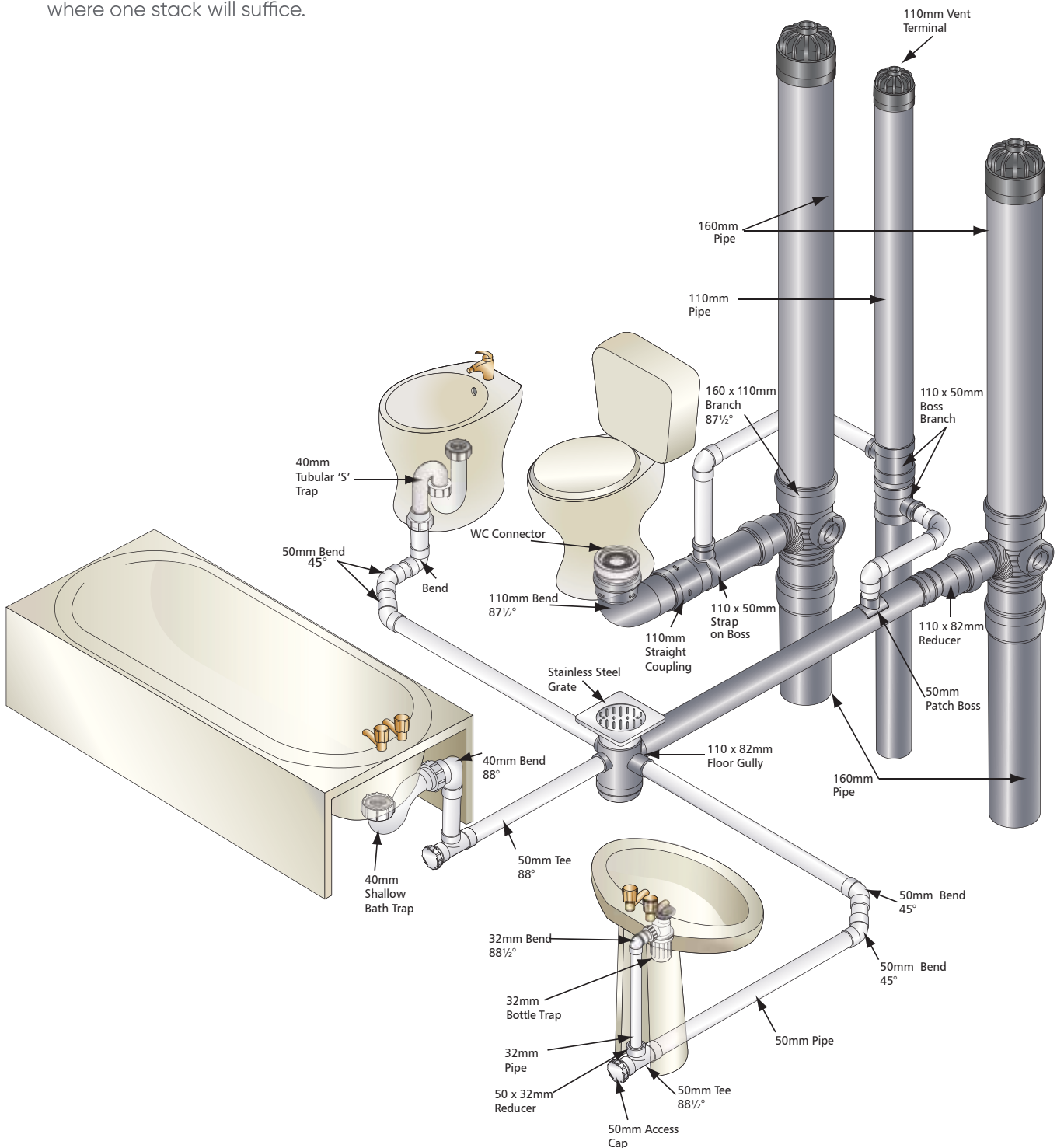

Branches at the base of soil stacks

For single dwellings up to three storeys high, the distance between the centre line of the lowest branch connection and the invert of the drain should be at least 450mm. For multi-storey systems up to five storeys high, the minimum distance should be 740mm, up to twenty storeys; a separate drain connection is required to level one. Over twenty storeys, levels one and two require a separate drain connection.

Over twenty storeys level one and two to separate drain connection

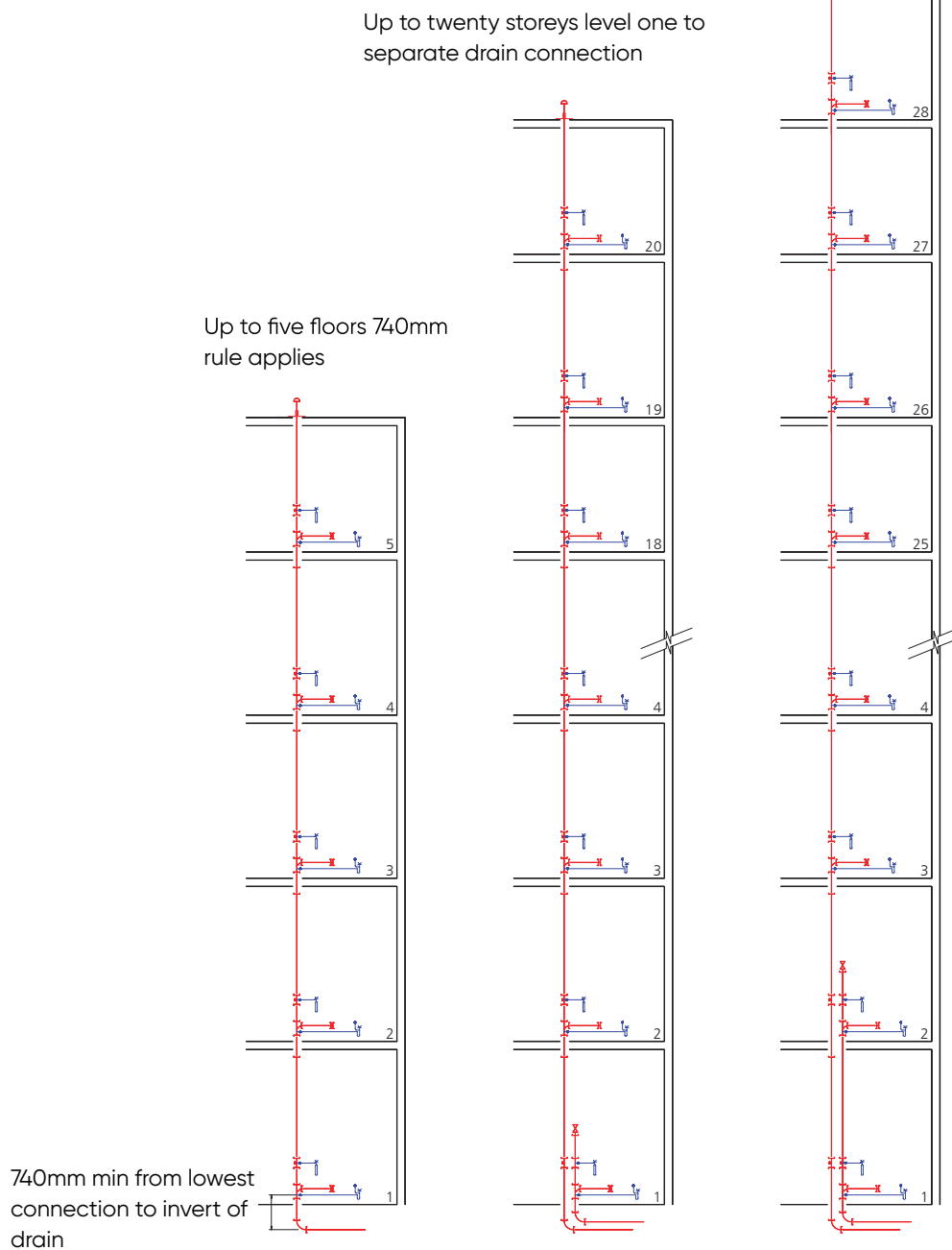

Offsets in stacks

Offsets in the wet portion of a discharge stack should be avoided wherever possible but where they have to be fitted a large radius or two 45° bends should be used to create each change of direction.

Offsets in lightly loaded stacks up to three storeys high do not require offset venting but on multi-storey buildings this may be necessary depending on the loading of the stack and the numbers of floors above the offset. The principles previously described for bends and branches at the base of a stack should also be applied.

This diagram shows a range of ways of connecting waste to a soil stack and the typical connections to appliances.

Stub waste

This technique is often used to connect isolated ground floor waste appliances such as basins, baths, shower trays and sinks to eliminate exposed pipework or low level ducting. The 110mm unventilated PVCu drain is terminated at finished floor level with a reducer and boss adaptor to suit the size of waste from the appliance.

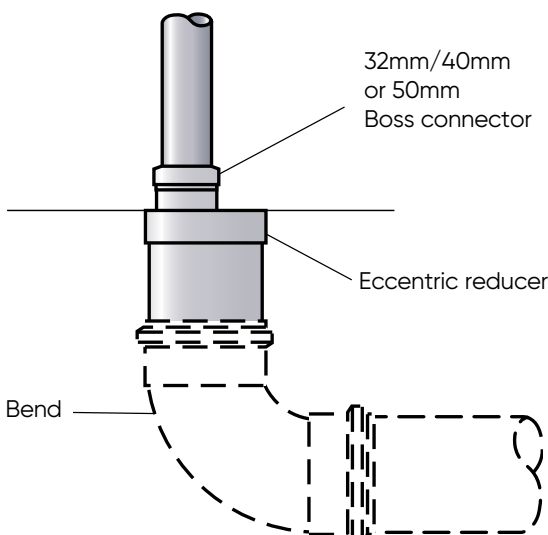

Base of a vertical soil & vent pipe

Min. Height	Application: Building Height
450mm	Up to 3 floors (single dwelling)
740mm	Up to 5 floors
One Floor	More than 5 floors
Two Floors	More than 20 floors

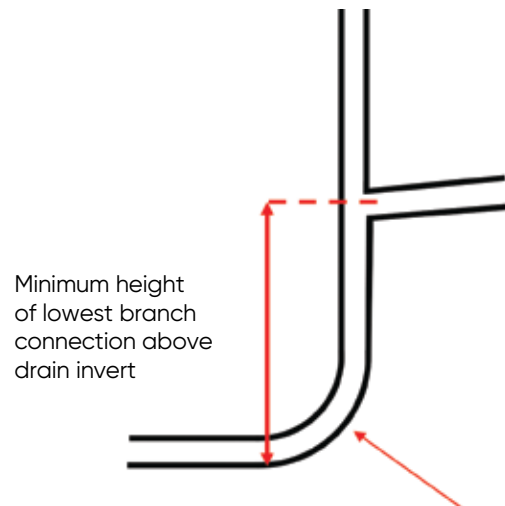

- Use a long radius bend with min radius $R = 200\text{mm}$
- Or use two 45° bends with a short piece of pipe

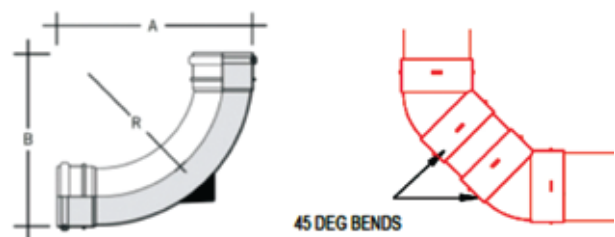

Stub stacks

An unventilated stub stack terminated with an access fitting may be used to connect a group of ground floor appliances to the building drain provided the vertical drop to the invert level of the drain does not exceed 1.5m from a WC and 2.5m from a waste appliance.

Where one or more stub stacks are connected to the same drain, the head of the run should be ventilated to atmosphere or air admittance valves fitted to each stub stack arrangement.

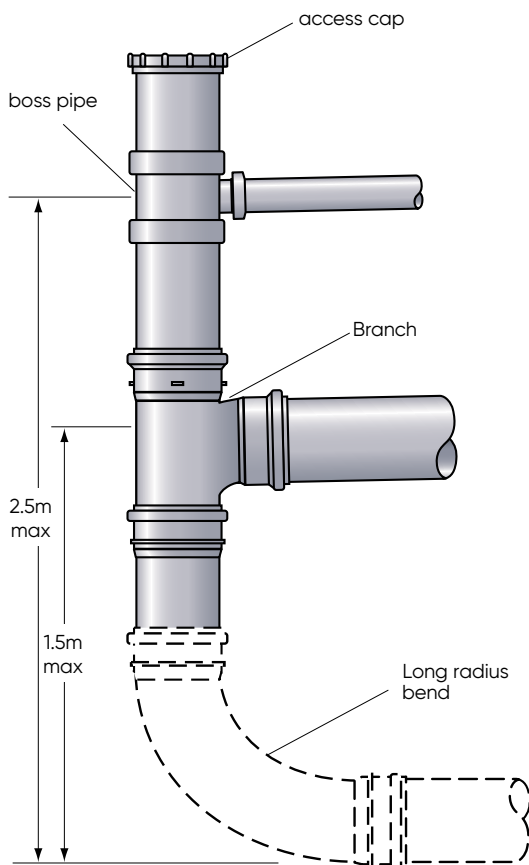

8-way collar boss

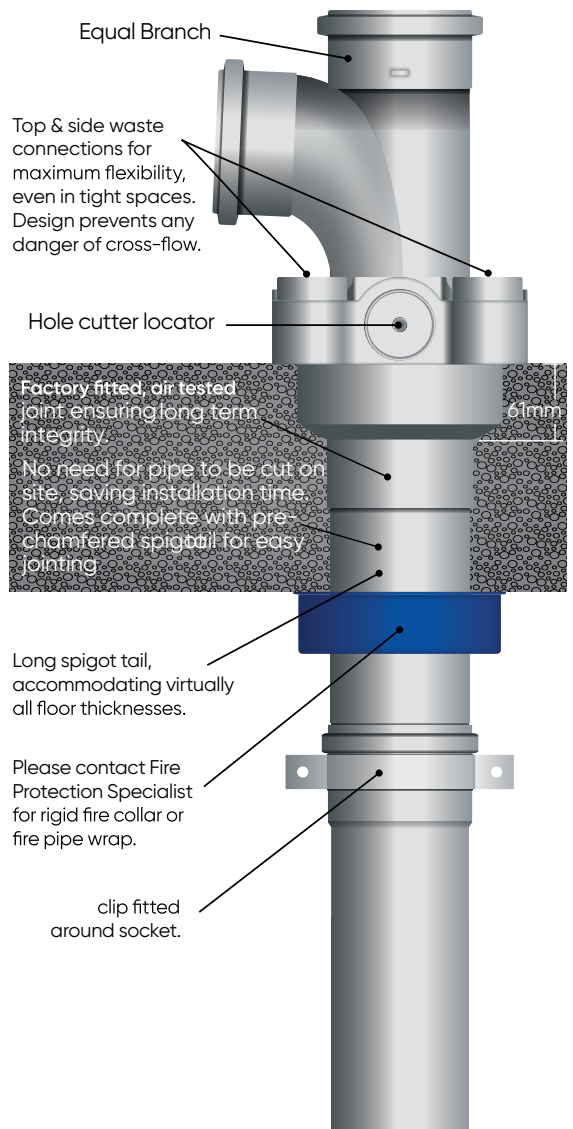

Prevention of Cross-flow

Where small diameter branch waste pipes connect to a discharge stack they must be arranged to eliminate the risk of cross-flow from one branch to the other. A branch creates a no entry zone for opposing waste connections, which varies depending on the stack diameter. No connections should be made within the restricted zone although entry is permissible on the centre line of the boundary directly opposite or at right angles.

To prevent cross-flow from a large diameter branch to a smaller waste connection, the latter should be made to the stack at or above the centre line of the larger branch, at right angles or at least 200mm below the restricted zone. Entry is permissible on the boundary centre line directly opposite or at right angles.

Stack size (mm)	Height of zone 'H' (mm)
82	90
110	110
160	250

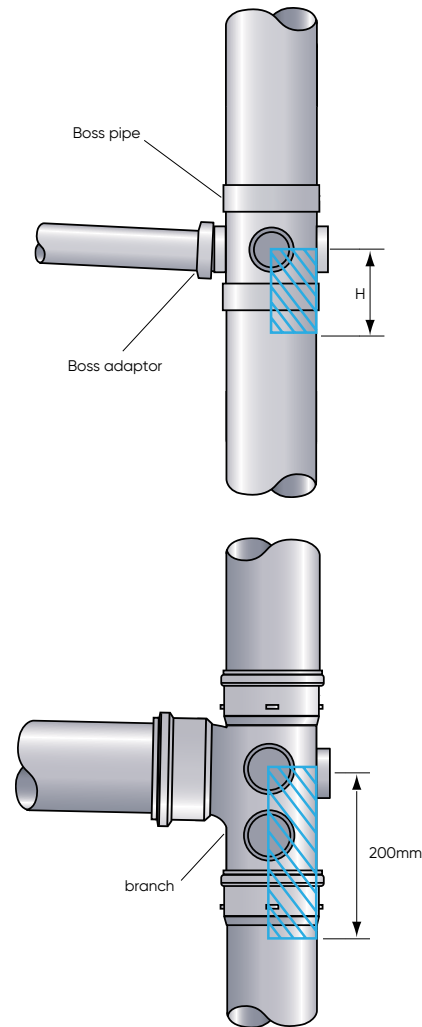

Branch pipe gradients

The gradient of a branch pipe should be uniform and adequate to drain the pipe and appliance efficiently. A minimum gradient of 18mm/metre should be adopted for 32, 40 and 50mm nominal size pipes but larger diameter 82, 110 and 160mm branch runs may be laid flatter at 9mm/metre fall where the discharge flow rate exceeds 2.5 litres/second.

Branch pipe lengths

The following information is taken from Table 6 of BS EN 12056: 2: 2000 and provides general guidance on the recommended lengths of unventilated branch pipes for a variety of sanitary appliances.

Appliances	Dia (mm)	Min.trap seal depth (mm)	Max. length of pipe (m)	Pipe gradient (%)	Max. bends (No.)	Max. drop H (m)
Washbasin or bidet	32	75	1.7	2.2	0	0
Washbasin or bidet	40	75	3.0	1.8 to 4.4	2	0
Bath or shower	40	50	No limit	1.8 to 9.0	No limit	1.5
Bowl urinal	40	75	3.0	1.8 to 9.0	No limit	1.5
Trough urinal	50	75	3.0	1.8 to 9.0	No limit	1.5
Kitchen sink	40	75	No limit	1.8 to 9.0	No limit	1.5
Dishwasher or washing machine	40	75	3.0	1.8 to 4.4	No limit	1.5
WC	110	50	No limit	1.8 min	No limit	1.5

The maximum lengths given above may be increased where the branch pipe is ventilated or an air admittance valve is used. For further details refer to the above standard.

Ventilation of Soil stacks

Fundamentally, an efficient drainage system design is about managing the mix of air and water. More precisely, it is about managing the air pressure regime within the boundaries that maintain a water seal in the trap. Marley offer 3 different product solutions to manage this.

1. Secondary Ventilation

Traditional drainage design incorporates the installation of a secondary ventilation stack and branch pipework system alongside the main soil and waste stacks to ensure this air pressure is maintained.

	Stack size (mm)	Secondary vent (mm)	Maximum capacity (l/s) Swept entries
Primary ventilated stack	82	–	2.6
	110	–	5.2
	160	–	12.4
Secondary ventilated stack	82	50	3.4
	110	50	7.3
	160	80	18.3

Soil stack capacity

The capacity of a soil stack can be increased by the installation of a secondary ventilated stack. The following information is taken from tables 11 & 12 of BS EN 12056-2: 2000 which illustrates this increase.

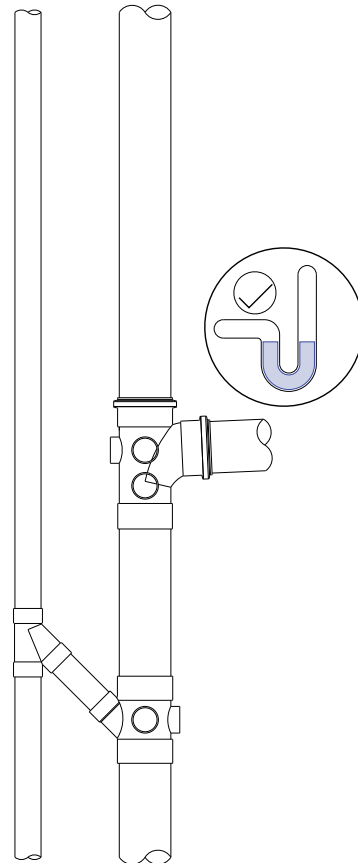

2. Active Drainage Ventilation

An active ventilated system provides relief at the Point Of Need (PON) by removing or attenuating an incoming pressure transient that, if left, could lead to trap seal depletion.

The single stack solution with the Studor P.A.P.A. and AAVs is ideal for high-rise applications, eliminating the need for roof penetrations.

The combination of the P.A.P.A., Maxi-Vent and Mini-Vent air admittance valves support a complete system to limit pressure fluctuations, guaranteeing the integrity of the traps.

Stack size (mm)	Maximum capacity (l/s)
110	7.3
160	18.3

Benefits of single stack with P.A.P.A system:

- Provides effective protection against positive/negative pressures in the drainage system
- Scientifically proven and tested for total peace of mind
- Reduces installed service space, slab & roof penetrations and passive fire protection measures

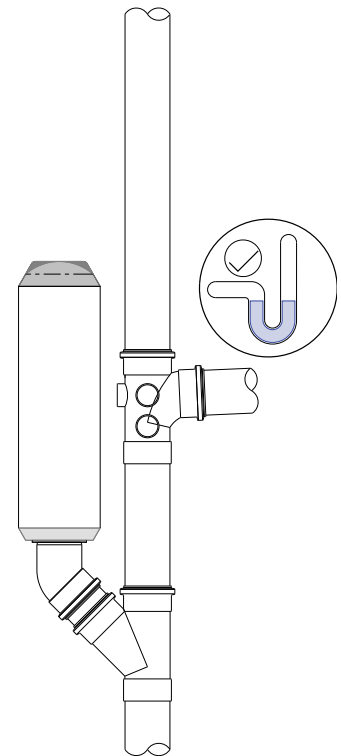

Maximum drainage flow for P.A.P.A. is illustrated alongside.

Air Admittance Valve

Installation guide for a row of 3 storey houses

First 4 houses: Can use AAV inside all homes

5 to 10 houses: One open vent required at head of drain - all others use AAV's

11 to 20 houses: Open vent head of drain and mid-point - all others use AAV's

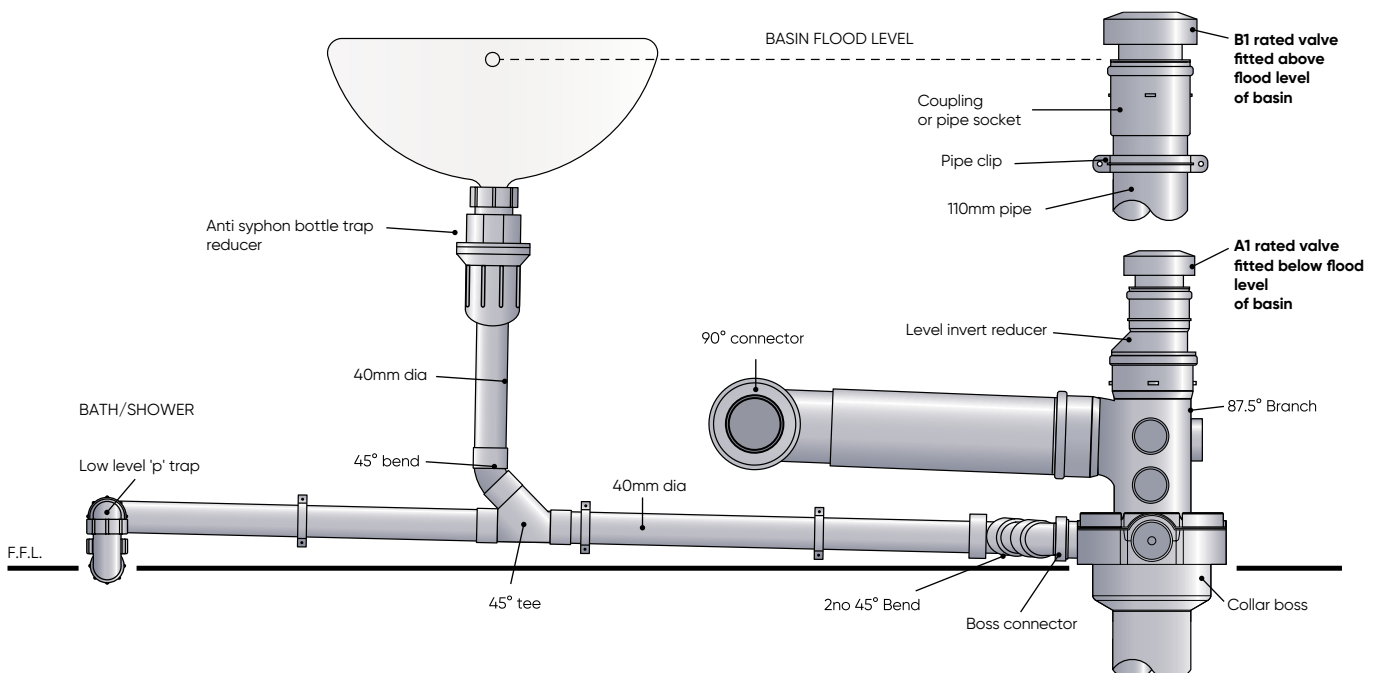

Soil & Waste – Joining Guide

Typical Pipe cutting and jointing

Pipe Cutting Guide (See Figure 1)

- Cut pipe cleanly with square edge with a fine tooth hand saw
- Chamfer 45 degrees for 2/3 wall thickness of pipe, using a medium file or rasp
- This is essential to ensure that the sealing ring is not displaced during insertion.

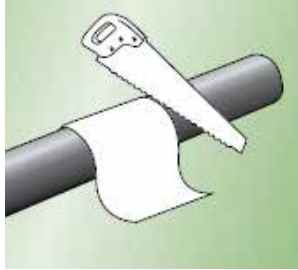

Figure 1.

Steps:

- Push-fit ring seal joints requires a 45° chamfer angle on the pipe edge
- Ensure the sealing ring is properly placed in the socket of the fitting
- Lubricate evenly around the pipe using only Silicone based lubricant to lubricate the joint
- Align correctly the components to be joined, push pipe or fitting into the socket
- Ensure that the expansion gap is maintained: 10mm expansion gap required every 6 meters
- Ring seal joints can be leak tested immediately

Push-fit Jointing Guide (See Figure 2)

The ring seal has been successfully employed as the principal method of jointing large diameter PVCu pipes and fittings since their introduction over thirty years ago. This particular technique has proved extremely reliable as the joint can accommodate thermal movement that will occur as a result of temperature variations. An expansion gap of between 5-10mm should be allowed within each ring seal socket as each full length of pipe is installed and fixed using socket and barrel pipe clips.

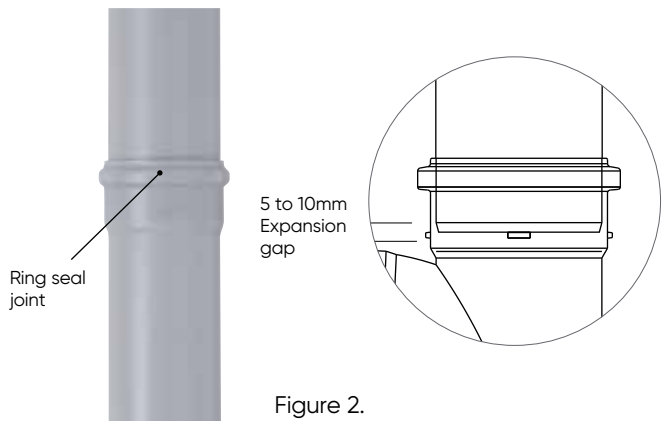

Figure 2.

Solvent Jointing Guide

Solvent weld jointing is also widely used and many components in the range are available with this facility to provide an effective alternative.

Steps:

- Insert straight cut pipe into socket (Solvent weld sockets do not need a chamfer angle)
- Mark the insertion depth on the pipe
- Remove the pipe add a liberal help of Marley Cement solvent weld in the socket and on the pipe
- Insert the pipe with a twisting action

Solvent cement fuses the two contact surfaces to make one homogenous joint and sets in 90 seconds.

Solvent weld joints are fixed and do not allow thermal expansion and cannot be tested for 24 hours. Ring seal joints must be incorporated to control thermal movement.

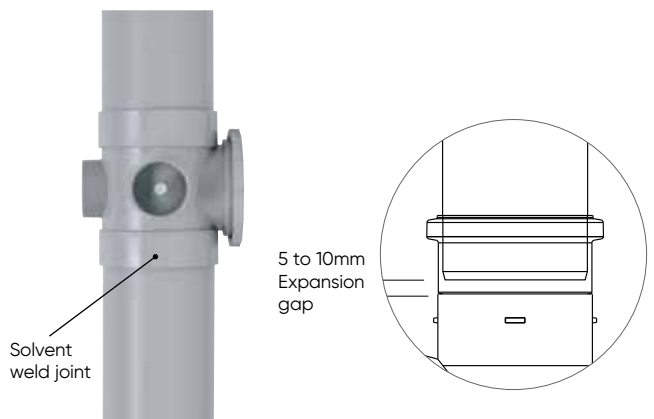

Floor gully

Trapped floor gullies are suitable for use as a shower outlet in bathrooms, wet rooms or as floor gullies for washdown areas in domestic, public and commercial buildings. The floor gully either has a 50mm or 82.4mm outlet, with three waste pipe inlets. The

The floor gullies provide a minimum 75mm water seal. The fitting is supplied with a loose base so that the body height can be reduced for casting in a shallow slab. A stainless steel grating, or PVCu grating, are available.

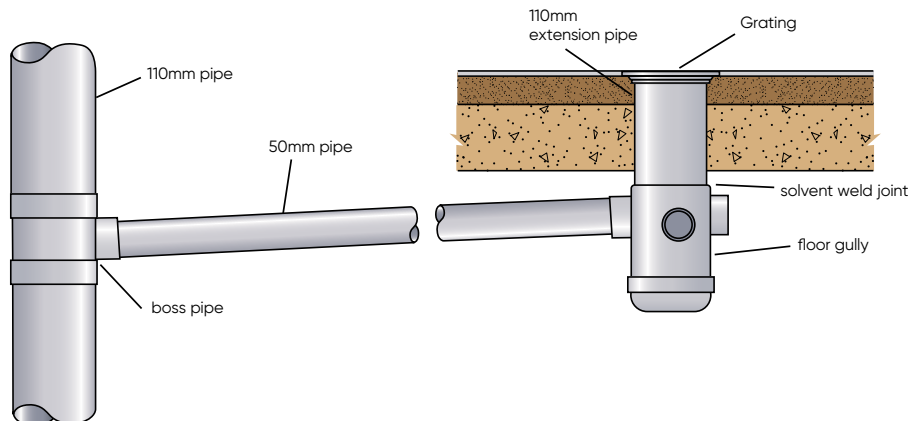

System connections

Boss branches

The Marley range of boss branches are designed to allow multiple waste pipe connections to be made to the discharge stack from different directions. Four different side entry combinations are possible together with a rear if required. Staggered waste pipe connections, directly opposite are not permitted as cross-flow could occur.

Compatibility

Boss pipes, boss connectors and strap-on bosses fitted with multi-fit 'T' ring seals are suitable for use with PVCc or ABS waste systems to BS EN 1566 or BS EN 1455-1, polypropylene to BS EN 1451-1 and metric size copper to BS EN 16090.

Un-perforated boss upstands on boss pipes, branches and reducers may be drilled to accept 32, 40 and 50mm boss connectors using hole saw. Knuckle bends may also be used as 90°

boss connectors for 40 and 50mm PVCc or ABS waste pipework.

Horizontal connections

The boss pipe is recommended for use in horizontal situations where connections to 110mm diameter pipe is made at 45°. This fitting has a 50mm solvent weld socket to accept PVCc or ABS waste pipes.

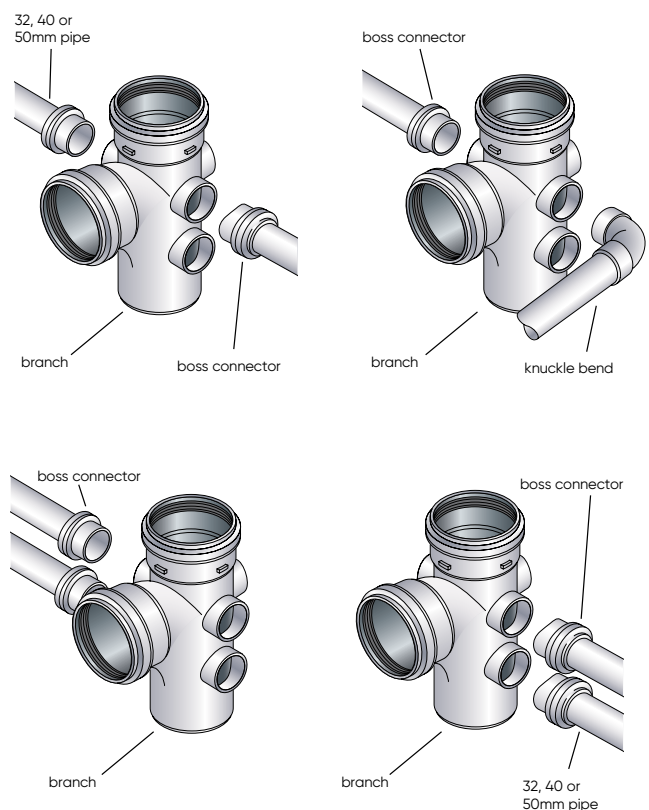

Boss pipe connections

Four different types of fitting are available to provide alternative methods of connecting small diameter waste pipes to 82, 110 and 160mm vertical discharge stacks.

Single boss pipes

Available with ring seal or solvent weld sockets for push-fit or solvent weld jointing, single boss pipes allow 32, 40 and 50mm waste pipe connections to be made at 87½° direct to the vertical stack.

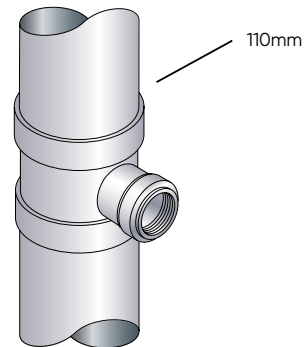

Multiple entry boss pipes

Supplied in ring seal or solvent weld options, all have 90° boss upstands moulded on each fitting with one inlet port open. Connection is made using the appropriate size Marley boss connector to suit 32, 40 or 50mm waste pipes.

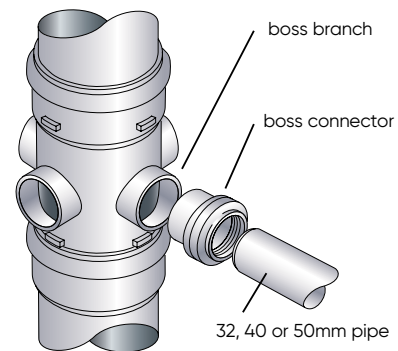

Patch bosses

Suitable for solvent weld jointing to new and existing 82mm diameter PVCu discharge stacks to accept 32, 40 and 50mm size PVCc or ABS waste pipework.

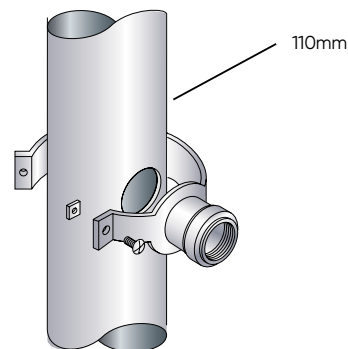

Strap-on-bosses

Primarily designed to permit 32, 40 and 50mm waste pipe connections to be made to existing 110mm PVCu discharge stacks, strap-on-bosses can also be used on new systems to provide flexibility of installation during different stages of construction.

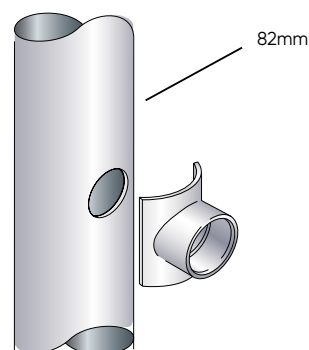

Soil & Waste – Pipe Support

Pipe Support

The Marley pipe support range was developed to meet the specific requirements of uPVC suspended sanitary pipework and drainage systems. Manufactured in zinc electro plated mild steel for internal use, the versatile range of components can be assembled to provide a robust, lightweight system suitable for most applications. The system also provides suitable control of expansion and contraction.

Experience has proved that an efficient and reliable uPVC sanitary pipework system depends considerably on the attention that is placed on the correct provision of **pipe support brackets**. This is particularly important in multi-storey buildings where care must be taken to ensure clips are positioned to control thermal movement at each floor level.

The arrangements of brackets and channel supports have been extensively tested and the assembly techniques used have been successfully employed on many domestic and commercial installations.

Single support

Recommended for waste or larger diameter pipework fixed within 500mm of the floor soffit.

Double support

Developed for use with larger diameter pipework fixed within 1.0m of the floor soffit.

Pipe brackets

The 110mm two piece pipe brackets are designed to fit round the ring seal socket of a pipe or fitting. Where intermediate support brackets are located, the PVC barrel clip collar is used as a spacer sleeve between the pipe and bracket.

Angle and side bracing

Angle braces should be provided at 6m centres to prevent lineal and thermal movement. Side bracing may also be necessary on long runs where there are no side connections to eliminate lateral movement.

Vertical pipes

The transition between vertical and horizontal pipework should be achieved using two 45° bends or a single 87½° long radius bend with a support bracket positioned as close as possible.

Branch connections

All branch connections into horizontal pipework should be made at 45° to ensure the discharge is swept in the direction of flow.

Structural fixings

It is recommended that 6mm rawlbolt or similar proprietary fixings are used to secure base plate and angle cleats to the structure.

Support brackets for vertical soil pipes

Plastic coated metal socket clips are designed to fit ring seal sockets and act as anchor brackets. These used in conjunction with uPVC intermediate pipe clips, control expansion and contraction and maintain the vertical alignment of the stack.

Material	BS Pipe Ø	Vertical Support Max
PVC-U	Ø82mm	Every 2.00m
PVC-U	Ø110mm	Every 2.00m
PVC-U	Ø160mm	Every 2.00m

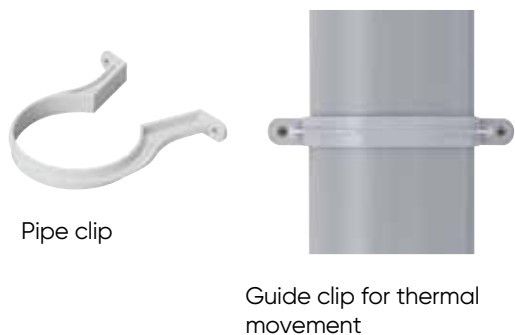
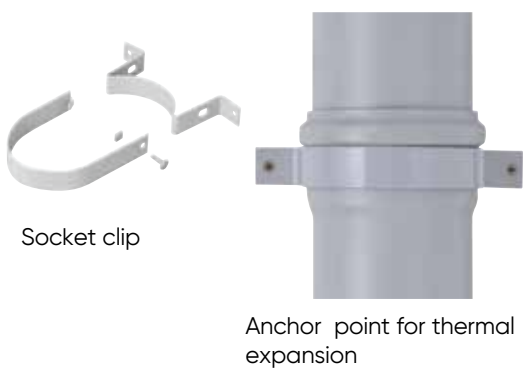
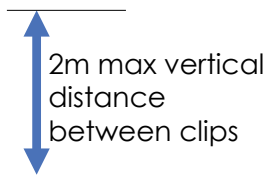

Support Brackets for Suspended Pipework

When suspending drainage with threaded rods (usually M10) drops should not exceed 300mm. Side bracing will be required on the expansion joints.

Important: Setting out the gradient fall line

Pipe Ø	Min Gradient	Pipe Support
Ø82mm	18mm / m	Every 1.0m
Ø110mm	18mm / m	Every 1.0m
Ø160mm	18mm / m	Every 1.2m

Single support

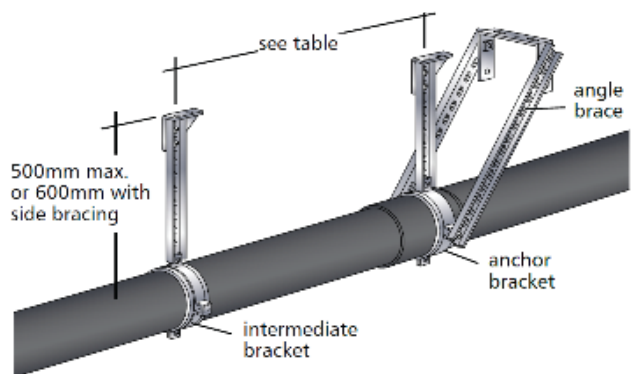

Double support

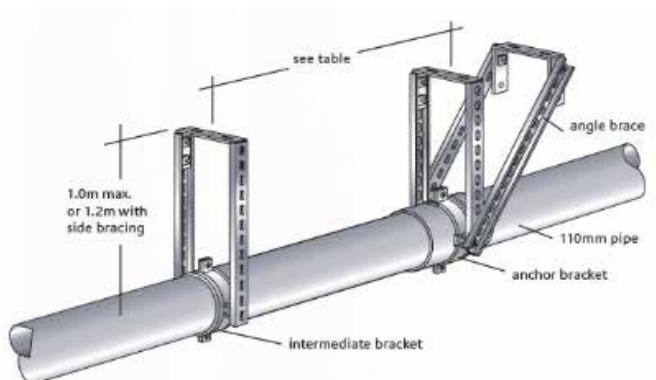

The above images show best practice with suspended pipework. When installing suspended pipework with non-Marley clamps and fixings, please ensure that while fittings are clamped (bracket tight), pipes should only be supported (bracket should allow for pipe to move within the bracket) to allow for thermal movement / expansion.

Waste Pipe: Support brackets and pipe gradient

Saddle pipe clip for waste pipes

Ø32, Ø40, Ø50



Material	Pipe Size	Horizontal Pipe Clips	Minimum Gradient	Vertical Pipe Clip Distance
PVC - U	Ø32, 40, 50	500mm	20mm / m	1.0m

Soil & Waste – WC Connectors, manifold & traps Guide

WC connections

Two different types of connectors are available to allow connection to vitreous china or stainless steel WC pans, slop hoppers and other similar sanitary equipment. Manufactured in PVC and eva (ethylene vinyl acetate) to accommodate a range of outlet sizes between 84 and 110mm sanitary pipework or underground drainage.

Connectors are supplied complete with flexible seal and retaining cap. Where the pan connectors are used, the WC socket must be trimmed to suit the length of pan spigot.

Ground floor toilets often have their own connection to the building drain to eliminate pipework and ducting. Where this occurs both types of connector are suitable for push-fit or solvent weld jointing to the 110mm PVC drain.

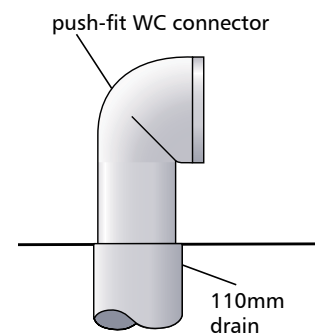
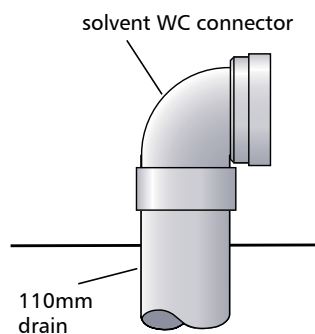
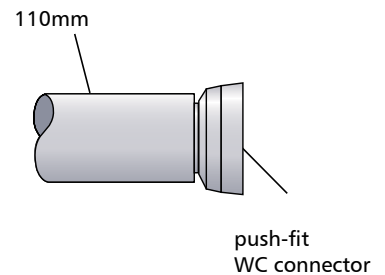
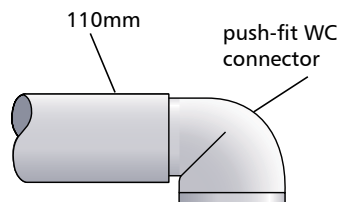
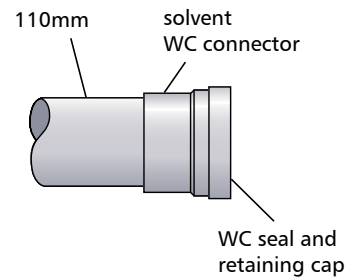
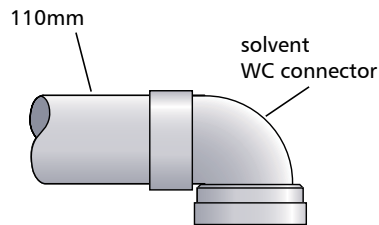

Combined Branch Waste

A combined branch waste is often used to connect a bath and/or shower and basin to the discharge stack as this allows waste pipework to be neatly concealed in a low level duct. Where this technique is adopted a 45° entry tee must be used to ensure the basin discharge is swept in the direction of flow towards the stack. The minimum distance between the bath or shower and basin connection should not be less than 500mm and it is recommended

that an anti-syphon bottle trap is fitted to the basin or a vent provided to protect the appliance from self-syphonage.

It is recommended that the distance of the combined waste does not exceed 3 metres, however, experience has shown that longer runs using 40 or 50mm pipework has proved successful provided adequate fall can be obtained to ensure self-cleansing velocity is maintained.

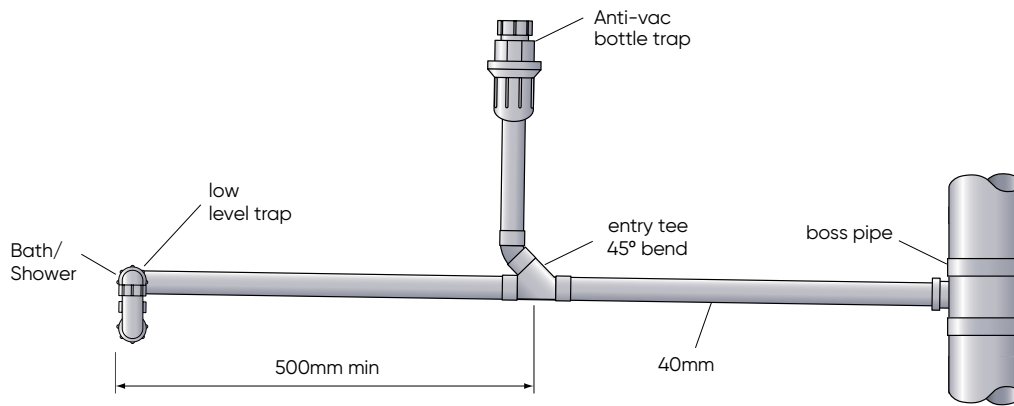

WC Manifold System

Developed for use in sanitary pipework systems in schools, hospitals, public and commercial buildings, the manifold system allows ranges of toilets to be connected to a horizontal float above floor level and eliminate the need for specially fabricated fittings.

The components are suitable for installation in a duct, or for fitting on the surface of the wall directly behind the pan. Where the manifold is fitted directly behind the range of toilets, the minimum distance between the end of the WC spigot and the face of the wall is 150mm. To facilitate varying angles and gradients the 110 x 90mm manifold branch has a radial socket to match both options of adjustable WC bend. When the selected bend is cut to the appropriate line and solvent welded into

the socket on the manifold branch a uniform fall is obtained between each toilet on the horizontal float.

To accommodate different dimensions between the WC spigot and horizontal float, the adjustable spigot bends may be trimmed by up to 35mm or the extension pipe can be used with the pan connector and cap & seal.

The WC socket must be trimmed to suit the length of pan spigot before it is fitted.

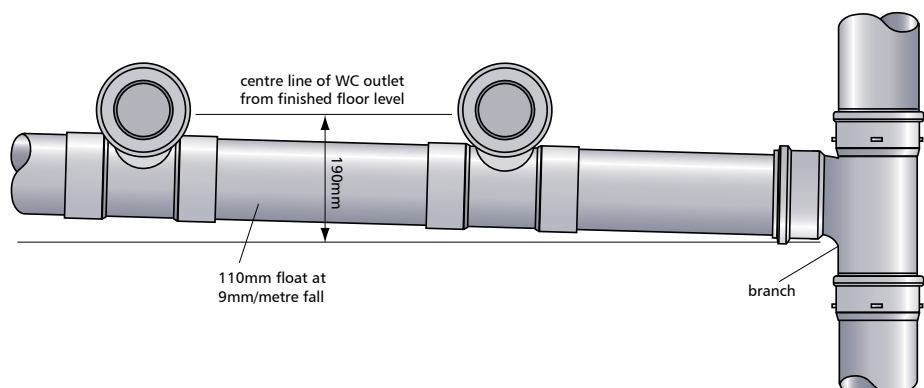

WC Manifold System

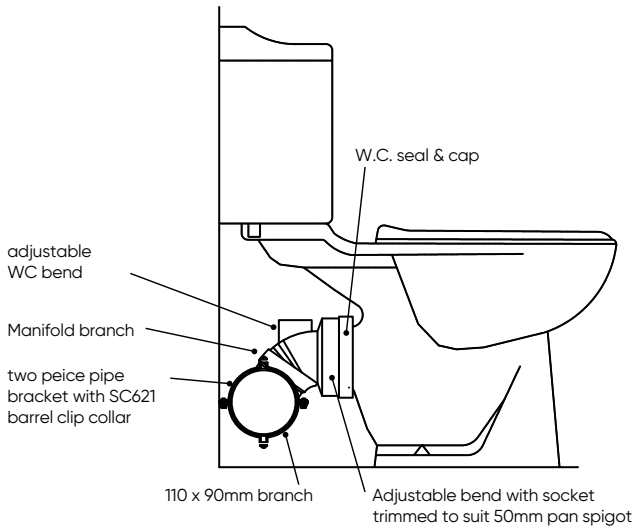

Manifold branch

Cut line	50°	55°	60°	65°	70°	75°	80°	85°	90°
A – projection (mm)	93	93	92	91	90	87	84	80	75
B – drop (mm)	69	77	85	93	101	109	116	123	130

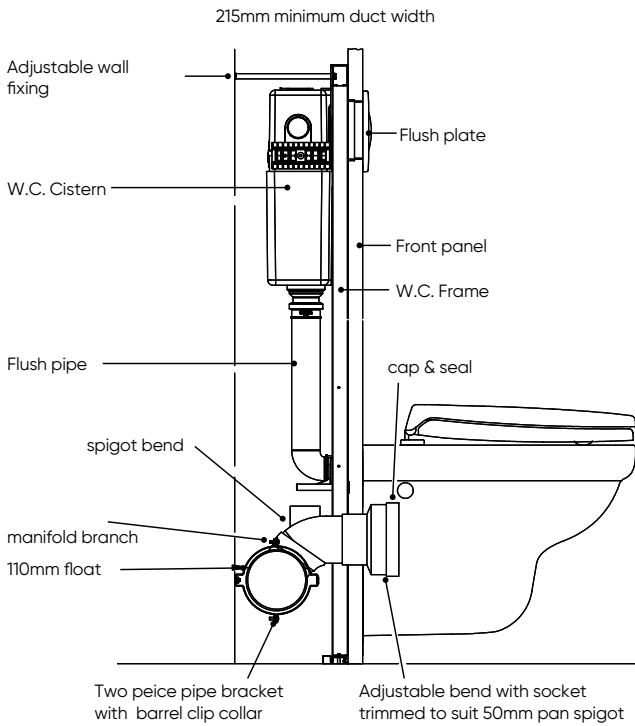
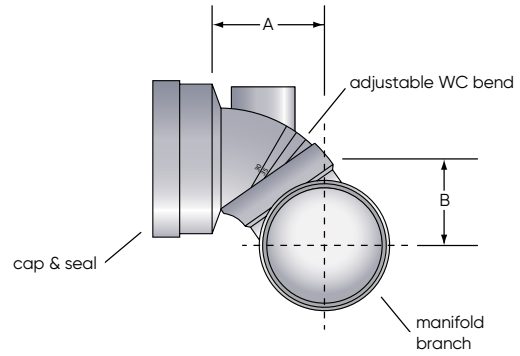

Manifold branch

Cut line	50°	55°	60°	65°	70°	75°	80°	85°	90°
A – projection (mm)	180	180	179	178	177	174	171	167	162
B – drop (mm)	69	77	85	93	101	109	116	123	130

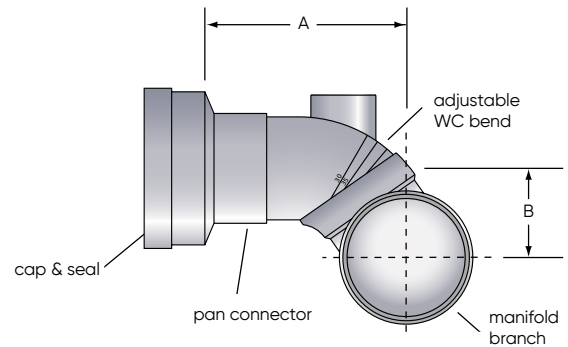

WC Manifold System

Up to six WCs can be connected to a soil stack using the WC manifold system and a single branch connection. By using a double branch connection, an additional six WCs can be connected. The table, right, details the angles of the manifolds for this installation.

NUMBER OF WCs	Angle of Manifold Branch					
	WC 1	WC 2	WC 3	WC 4	WC 5	WC 6
6	80°	75°	70°	65°	60°	55°
5	75°	70°	65°	60°	55°	
4	70°	65°	60°	55°		
3	65°	60°	55°			
2	60°	55°				

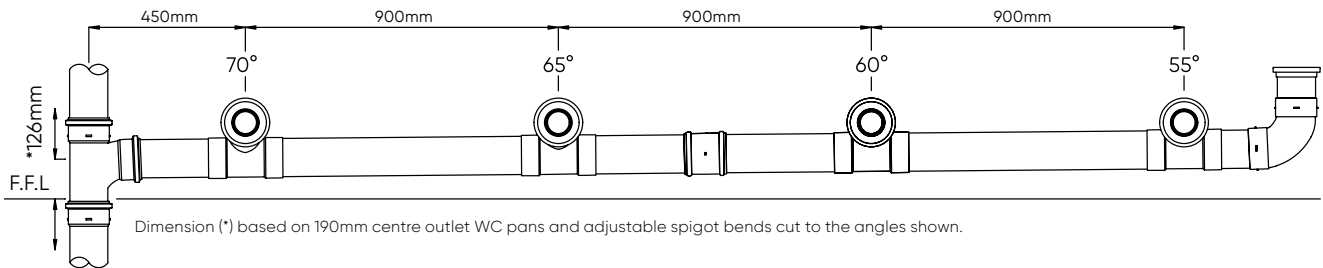

1. Select the adjustable bend angle required from the above diagram according to the WC position. Cut the bend with a hacksaw, removing the unwanted portion.

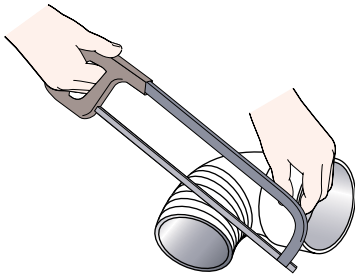

2. File away any rough edges from the face of the fitting and wipe clean the bend and branch, with a dry cloth. Before joining, the bend and branch should be checked for position and alignment, both parts being marked to ensure accurate assembly.

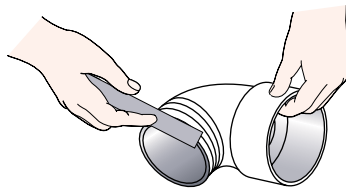

3. Apply a uniform coat of Marley solvent cement, to the short branch radial socket and to the external surface of the bend body.

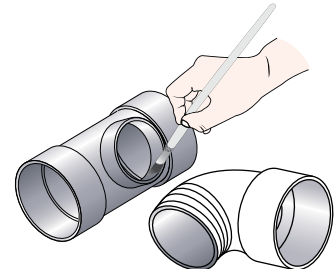

4. Assemble the branch immediately, insuring that the marked lines on the fitting coincide. Do not twist the two parts of the branch during this operation, but maintain steady pressure until the spigot of the bend comes to rest against the internal surface of the branch socket. Quickly wipe off any surplus solvent cement from the inside and outside of the completed joint and hold in position for approximately 15 seconds.

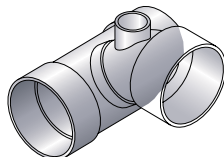

5. Trim the WC socket to suit the toilet pan spigot length and remove any swarf with a file. Place the seal in the socket, apply a uniform coat of solvent cement about 15mm wide to the outside of the socket and inside the retaining cap. Push onto the socket and wipe off any surplus solvent cement.

To accommodate varying dimensions between the WC spigot and the centre line of the horizontal pipe run, the adjustable spigot bend or extension pipe can be used with WC connector.

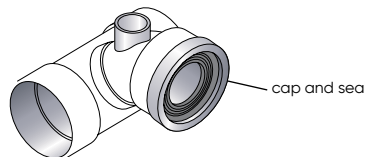

WC Connectors Installation Guidelines

Our comprehensive range is one of the largest on the market, and covers spigots of 74mm – 114mm, ensuring an accurate fit, regardless of the make and model of sanitary chinaware.

Selecting the right WC connector

Measure the OUTER diameter of your spigot.



Measure the INNER diameter of your pipe.



Then take a look at the dimensions provided for the individual connectors to find the best matches.

Know your WC pan spigot

Key	Size	Pipe Suitability	British Standard
PAGE: 24 – 28	97-108 mm	Modern & New Pans	BS 5503 & BS 5504
PAGE: 29	108-114 mm	Old & Syphonic Pans	BS 1213
PAGE: 30 – 31	76-95 mm	Stainless Steel Pans	–

Know your pipe

Key	Size	Pipe Suitability	British Standard
STANDARD ①	99-105 mm	uPVC / Clay / Cast Iron	BS 4514/BS 4660/BS 65/BS 416
CAST IRON ②	88-92 mm	Traditional Cast Iron	–
OLD ③	74-77 mm	–	–
COPPER ④	105-108 mm	Copper	–

All WC connectors are made to fit pans conforming to BS 5503 and BS 5504, including ones with bosses.

Sealing flanges

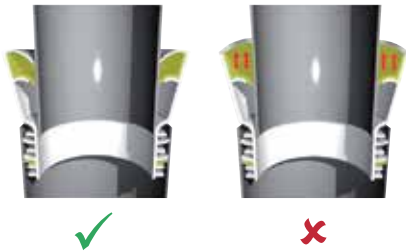

When connecting a WC connector to the pan spigot, the sealing flanges must be pushed inside with the pipe.

Don't pull the other sealing flange out over the top of the pan spigot – it may lead to leaks.



It's easy to get it right!

When you install a new toilet, in a new build development, you should use a WC connector. When you refurbish an old toilet, you need to use a connector (see page 69).

Make sure you know your pans and spigots

Pan dimensions

- 97 – 108mm Modern Pans
- 108 – 114mm Old Pans
- 76 – 96mm Stainless Steel

Spigot sizes

- ❶ 99 – 105mm Standard
- ❷ 88 – 92mm Cast Iron
- ❸ 74 – 77mm Old
- ❹ 105 – 108mm Copper

Multilink

Multilink is a unique fitting which sleeves the fins of all 99 – 105mm outlet Multikwik pan connectors.

Enabling direct connection to be made to the inlet of another pan connector.



Space Saver Bend

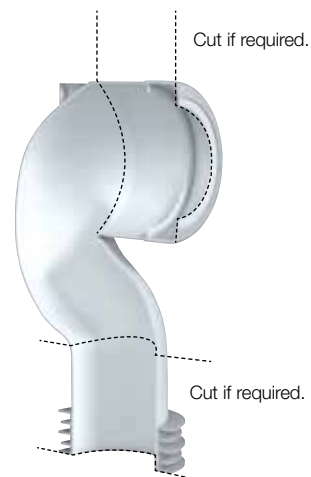

Soil Pipe Extensions

Available for 4", 3½" and 3" a Multikwik Soil Pipe Extension can be cut to required length, removing the unsightly existing pipe within the bathroom.

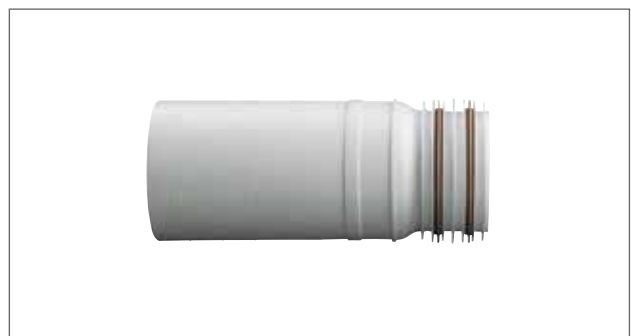



Underground Installation Guide

- Design considerations
- Pipe laying
- Gully combinations
- Underground installation
- Storage & safety

Underground Design Considerations

Design Considerations

The following standards deal with drainage design:

- BS EN 752: Drain and sewer systems outside buildings.
- BS EN 2015: Construction and testing of drains and sewers.

The design and layout of drainage and sewerage systems should comply with The Building Regulations and Water Authority Specification. Reference should also be made to the Sewers for Adoption manual.

The following information is provided only as a general guide to good practice for the design of underground drainage systems. For full details please consult the relevant documents referred to left.

Means of access

Access is required to drainage installations for testing, inspection and removal of debris. Access to drainage allowing rodding in both directions can be provided by inspection chambers, manholes and other access fittings. Rodding eyes provide access for clearance of debris in the direction of flow only and should thus be used in conjunction with an access chamber or manhole at a point downstream.

No part of the drain or sewer should be more than 50m away from a manhole. The distance between points should therefore not exceed 100m.

For full guidance as to provision of access, reference should be made to BS EN 752. The table right details the maximum spacing of the access points as detailed in the above standard.

	To junction/ branch	To access fitting	To inspection chamber	To manhole
From start of external drain		12	22	45
From rodding point	12	12	22	45
From access fitting	12	12	22	45
From inspection chamber	12	22	45	45
From manhole			45	90

Gradients

Foul water drainage systems are generally designed to run at a maximum of three quarters full bore. Pipe gradients should be established such that the velocity does not fall below 0.70 m/s to ensure adequate self-cleansing.

A 110mm foul drain taking the discharge of less than 1 l/s should be laid at a 1:40 (25mm per metre) fall. A foul drain taking the discharge from a minimum of one WC can be laid at 1:80 (12.5mm per metre).

Gullies incorporating in foul water or combined drainage systems must have a 50mm minimum water seal.

The table right is taken from BS EN 752 and provides guidance on minimum gradients for different size drains.

Peak flow (a) litres/second	PVCu pipe size (mm)	Minimum gradient
<1	110	1:40
>1	110	1:80 (b)
	160	1:150 (c)

(a) Peak flow based on probability flow calculation method

(b) Minimum 1 WC

(c) Minimum 5 WCs

Surface water drainage systems may be designed to run full bore.

Physical characteristics

Dimensions and weights

	Material	BS nominal size (mm)	Min	Max	Wall thickness (mm)	Weight kg/metre
Solid Wall	PVCu	110	110.0	110.3	3.2	1.7
		160	160.0	160.4	4.0	3.0
		200	200.0			

Dimensions and weights

	Material	Nominal size DN/1D (mm)	Mean Internal Diameter (mm)	Nominal External Diameter (mm)	Weight Minimum kg/m
	PVCu	150	145	160	1.85
		225	226	250	4.20
		300	297	315	7.00
	PVCu	150	148	160	1.25
		225	230	250	2.75
		300	302	315	4.65

Pipe strength

	Pipe type	Pipe size	SN N/m ² @ 20°C
	Marley solid wall	110mm	8000
	Marley solid wall	160mm	4000
	Marley solid wall	200mm	

Underground Design Pipe Laying

The following information is based on the recommendations in BS 5955: Part 6 'Installation of PVCu pipework for gravity drains and sewers' and BS EN 1610 'Construction and testing of drains

and sewers' and is intended as a general guide to good practice in the selection of bedding and backfill materials for Marley solid wall and Quantum underground drainage systems.



Excavation

Trenches should not be open for extended periods in advance of pipe laying and should be backfilled as soon as possible. It is essential that the sides of the trench are adequately supported during pipe laying.

Trench widths should be as narrow as is practicable but not less than the pipe diameter plus 300mm to allow adequate side fill to be placed. Deeper excavations should ideally incorporate a sub-trench in accordance with the diagram opposite.

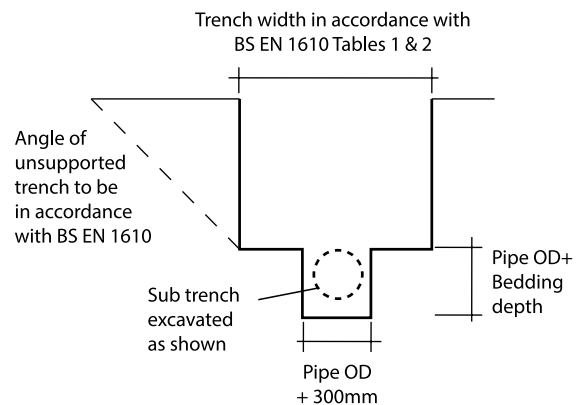

Granular material for bed & surround of PVCu drains and sewers

Suitable imported granular material for bedding and surrounding PVCu solid wall and Quantum pipes for private and adoptable sewer applications is detailed in the table opposite:

Grading complying with the requirements of BS EN 1610.

Nominal pipe size	Granular material size
100/110mm	10mm nominal single-size
	14 to 5mm course graded
150/160mm	10 or 14mm nominal single-size
	14 to 5mm course graded
150/225mm and over	10,14 or 20mm nominal single-size
	14 or 20 to 5mm course graded

Bedding & backfill

Where the as-dug material is suitable*, the bottom of the trench may be trimmed to form the pipe bed and the as-dug soil used as sidefill and backfill in accordance with BS EN 1610 bedding construction type B (see drawing below).

Where the as-dug material is unsuitable as bed and surround, installation should be carried out in accordance with BS EN 1610 bedding construction type 1, as shown below.

Trenches should be excavated to allow for the depth of bedding material. Before any pipework is installed the bedding material should be laid evenly along the bottom of the trench.

The sidefill material must be the same as the bedding material and extended to the crown of the pipe and be thoroughly compacted.

Where the backfill above the pipe contains stones larger than 40mm or where the pipework is deeper than 2m in poor ground, the granular material must extend at least 100mm above the pipe crown. Alternatively, backfill material can be graded to eliminate stones exceeding 40mm and this selected material used for the first 300mm above the pipe.

When the pipes are to be laid in rock, compacted sand or gravel, or in very soft or wet ground requiring mechanical means of trimming, the bedding should be a minimum of 100mm.

*Suitable material is defined as material in accordance with the recommendations of BS 5955: Part 6: Appendix A, having a maximum particle size not exceeding 20mm.

It is important to ensure that the ground is prepared correctly and that suitable bedding and backfill material is used, depending on the soil type and the loading required.

Shallow domestic drains

Pipes laid at depths less than 600mm and which are not under a road should, where necessary, be protected against damage by placing over them a layer of concrete, paving slabs or similar. A minimum 75mm cushioning layer of granular material must be laid between pipes and the slabs or concrete.

Where drains are laid in fields, additional protection may be required from heavy vehicles and equipment. It is recommended that the installation is carried out with a concrete slab spanning the trench as shown for drains under private roads (on opposite page below).

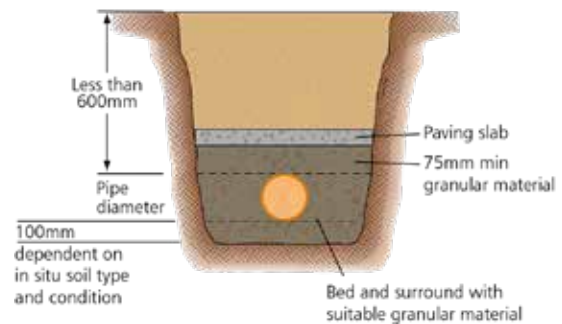

Drains under solid ground floors

Drains often have to be laid under buildings in order to connect sanitary pipework which has been positioned some distance from the outer walls. Where this occurs, deep hardcore within the foundation boundaries should be compacted first. The trench for the pipe should then be excavated and suitable material employed for the bedding and backfilling operation. If trenches are dug from original ground, pipes may be laid and surrounded as necessary before the top layer of hardcore is formed. Where a pipe passes through a wall or foundation of a building, a lintel or sleeve should be built -in to provide clearance around the pipe.

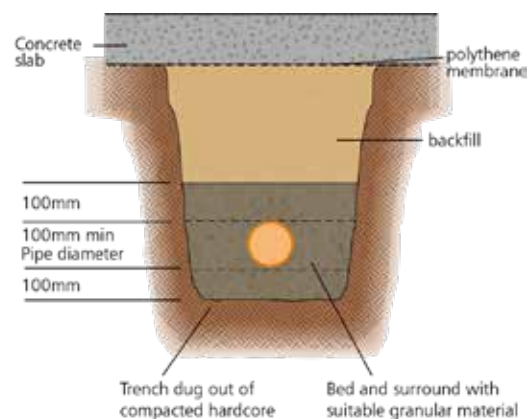

Concrete bed & surround

The flexible nature of PVCu pipes enables them to accommodate ground movement and other differential settlement that may occur under normal conditions. Therefore, the use of concrete bed and surround is not recommended and only under special circumstances, at very shallow cover depths or where it is necessary to safeguard foundations, should it be used. Where the use of concrete bed and surround is unavoidable, it is recommended that pipes are laid in 3 metre lengths and a compressible board is shaped to fit around each joint. Pipes should also be wrapped with polythene to prevent the ingress of cement slurry into ring seal joints.

Drains under private roads

If the depth of cover under a road or driveway is less than 0.9m, a concrete slab spanning the trench width is required.

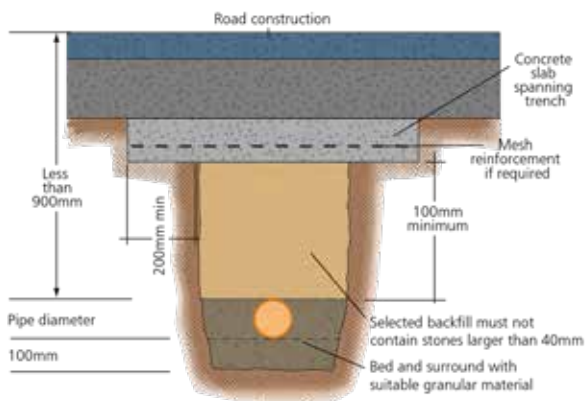

Adoptable sewers under roads

For adoptable sewer applications pipe bedding details should be in accordance with the Water Industry Specification. Selected as-dug material may be used for bedding and sidefill provided it meets the evaluation procedure and compaction fraction test values specified in WIS 4-08-01. The minimum cover under public roads should be 1.2m to the top of the pipe. The above information is for general guidance only and detailed proposals with regard to bedding and sidefill materials for sewers must be submitted to the relevant Adopting Authority for formal approval at the design stage of the project.

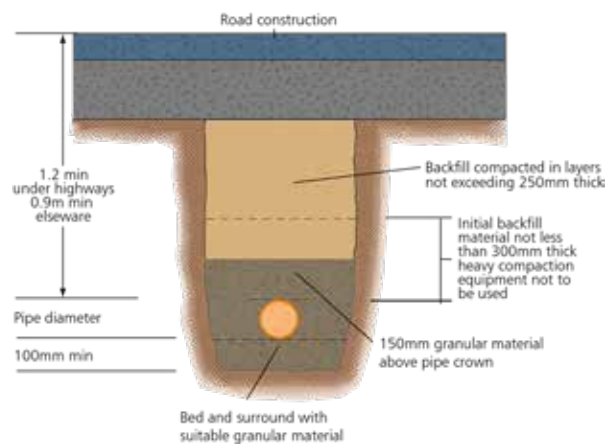

Underground Gully Combinations

A comprehensive range of gully components are available, allowing a wide variety of gully combinations to be assembled on site to accommodate different applications.

Square or rectangular gully hoppers

The square or rectangular gully hoppers and the gully inlet raising piece all have connections for small diameter pipework above the trap water level but below the gully grating.

Waste pipes can be connected using standard Marley universal boss adaptors, as illustrated.

The larger diameter upstands on the square or rectangular gully hoppers are designed to provide a solvent socket connection for 68mm circular rainwater pipes.

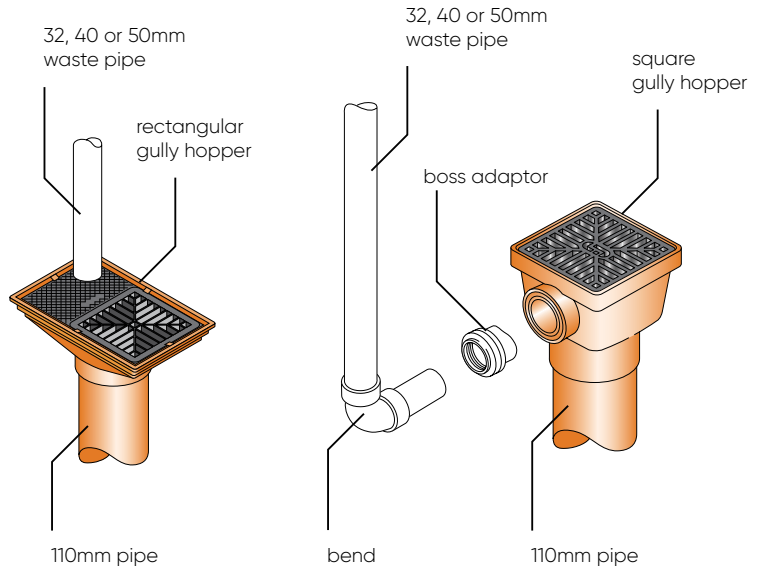

P trap gully

The double socket design of the P Trap Gully makes it ideal for use in restricted spaces and allows the trap to be orientated to suit the direction of the outlet pipe.

Both the square and rectangular hoppers can be connected to the gully using a short length of 110mm pipe cut to suit ground level.

The gully grating can also be used with the raising piece to receive waste pipe connections below ground level.

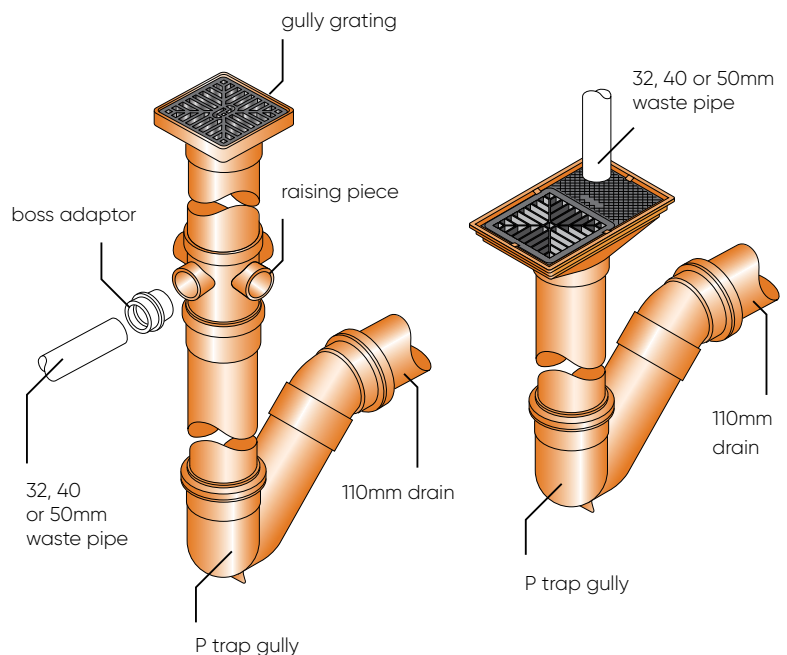

Bottle gully

The Hunter bottle gully is ideal for new or replacement installations and it provides the facility for direct 110mm connections and waste pipe connections via boss adaptors.

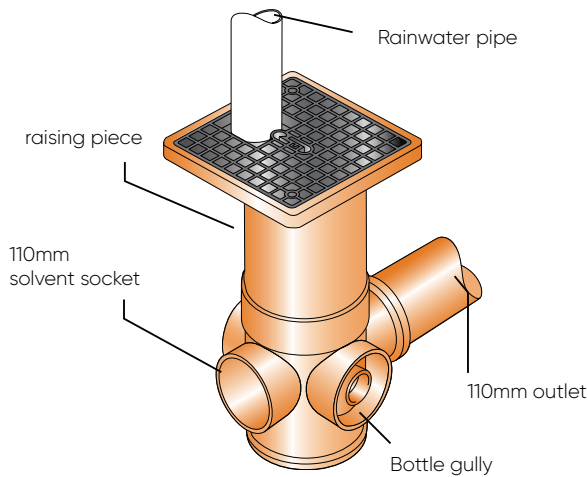

The fully rotating gully body allows the outlet to be orientated to suit the drain connection. A removable rubber plug provides access for cleaning.

The gully raising piece allows the gully to be installed at depths up to 520mm.

Installation procedure for bottle gully

1. Cut raising piece to required length by saw
2. Lubricate and push fit raising piece into top of gully body.
3. Gully frame spigot can then be solvent welded into top of raising piece. The gully grating may be secured to the frame if necessary with two 6 x 13mm self tapping pan head corrosion resistant screws (not supplied).

Road gullies

The Marley Gully Pot Liners meet the requirements set out in DTp 'Specification For Highway Works' for use as permanent shuttering when forming an in situ concrete gully.

For DTp applications gully construction details to be in accordance with DTp 'Highway Construction Details' Drawing No. F13.

A standard seal and seal cap are provided with each gully pot liner. These are to be fitted to a Quantum coupling or bend to enable a

direct push fit connection to be made to the gully pot spigot outlet.

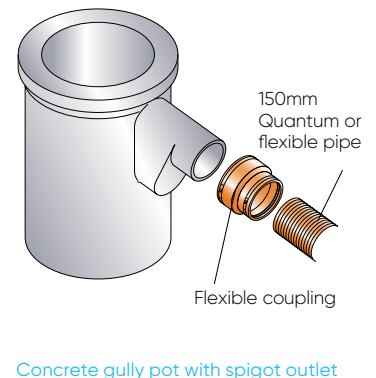
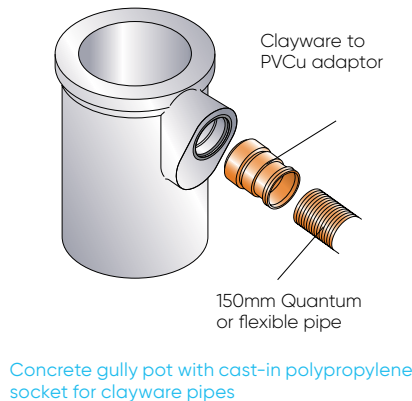
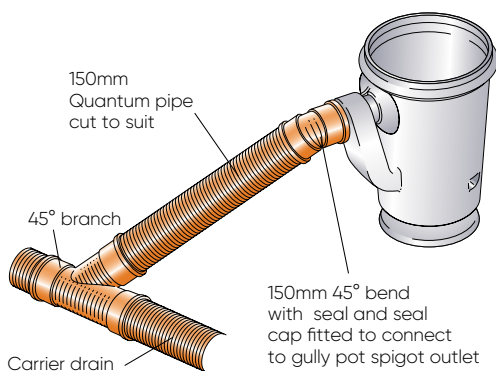
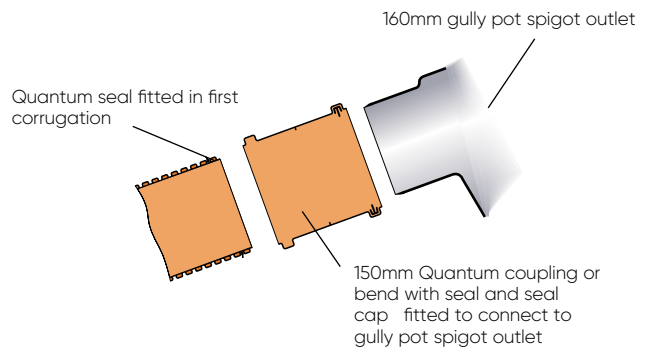

Underground Installation

Future connections

If a drainage system is likely to be extended in the future, branches at appropriate locations should be installed with the branch pipes blanked off with socket plugs. However, should it be required to install a new branch connection into an existing drain the following procedure should be adopted:

1. Materials required:- Branch fitting of appropriate size. Two short lengths of pipe (minimum length 300mm). Quantum pipe seals. Two slip couplings.
2. Fit the two short lengths of pipe into the branch fitting using the standard jointing procedure shown on page 44. Mark ends of pipe at half a coupling depth.
3. Use this assembly to mark the length of existing pipe to be removed and then cut out the section of pipe.
4. Ensure the ends of the existing pipe are free from dirt, swarf, etc.

Lubricate two slip couplings and slide fully over the ends of the existing pipe past the first corrugation.

5. Fit Quantum pipe seals to the first corrugation of each pipe end with the seals handed as illustrated to allow the couplings to slide back over the seals.
6. Lubricate all pipe seals and place branch assembly into position with branch pipe in desired plane.
7. Slide couplings back over joints using marks to ensure couplings are centralised on joints.

The above method of constructing a new connection to an existing drain meets the requirements of BS EN 1610: 2015 Clause 9-2.

A Quantum branch fitting can be installed into an existing concrete or clayware drain by following a similar procedure as described above but utilising appropriate flexible coupling in place of the slip couplings.

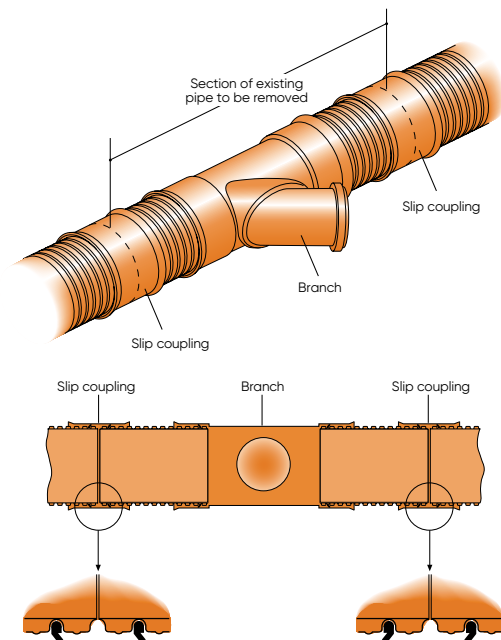

Pipe seals to be handed as shown to allow couplings to slide back over joint

Testing drainage systems

Air or water testing of systems should be carried out as required by the particular approving Authority. Reference should be made to the following documents for guidance:

Building Regulations Part H—Clause 2.26.

BS EN 1610: 2015 Sections 12 and 13.

It is recommended that air test method LA is adopted. However the standard water test can also be used.

Due to the non-absorbent nature of plastic materials the one hour conditioning period is not necessary prior to commencing a water test.

Rodding equipment

Marley underground drainage systems may be rodded using continuous flexible rods, sectional polypropylene rods or other similar flexible systems. Rodding heads should incorporate a guide roller, and rigid couplings between sectional rods should not exceed 100mm in length.

Pointed or boring type metal fittings are not recommended. Mechanical rodding techniques may be used with the exception of rotating toothed root cutters. These devices were primarily designed for use on traditional pipe materials where joint failure has occurred and allowed the ingress of roots. The incidence of PVCu ring seal joints failing in this way is extremely rare.

Water jetting uPVC drains and sewers

High pressure water jetting is now used extensively and is a recommended technique for the general cleaning, de-scaling and removal of blockages from both Marley solid wall pipes and Quantum drainage systems.

The Code of Practice for Sewer Jetting published by The Water Research Centre contains detailed guidance on the use of this type of equipment for drain and sewer maintenance. Adherence to the recommendations contained in this document is strongly advised when jetting all pipe materials.

The Code of Practice recommends for all house drainage systems and sewers where exact details of the condition, age and pipe material cannot be verified that a jetting pressure of 130 bar (1900 psi) is not exceeded.

Independent jetting trials for blockage clearance in PVCu pipes have conclusively demonstrated that the improved hydraulic performance and smoother internal bore allows most types of blockages to be removed using standard rear facing jet nozzles at jetting pressures well below the maximum recommended in the Code.

The Code of Practice recommends for all pipe materials that static jetting above 1900 psi is used only following confirmation that the pipeline being jetted is in good structural condition. Where up to date and accurate records of the condition of the sewer are unavailable a CCTV survey may be required prior to jetting above 1900 psi.

The Code of Practice recommends a maximum jetting pressure of 180 bar (2600 psi) for uPVC pipes, when using a standard jet head.

Where the distance from the access point to the blockage exceeds the travel capability of the standard jet head running at 180 bar (2600 psi) the use of a low impact jet head will allow higher pressures (thus great running distance) to be achieved without increased risk of pipe damage.

The jet head manufacturer's recommendations for maximum operating pressures should be observed when using these types of jet head.

Health and Safety

Safety

The relevant regulations as outlined in the Health and Safety at Work Act 1974 should be followed. Also follow the recommendations contained in the booklet 'Safe Working in Sewers and Sewerage Works' published by the National Joint Health and Safety Committee for Water Services.

Transportation and handling

PVCu pipes and fittings are strong and lightweight and therefore very easily handled, however, reasonable care should be exercised. During transportation loose pipes should preferably be loaded and unloaded by hand but if mechanical equipment is utilised, web or rope slings are recommended.

Larger quantities of pipes are delivered in secure bundles within timber frames and wherever possible the pipes should remain within this packaging until required for installation. It is recommended that pipe bundles are unloaded by forklift or by using web or rope slings.

Fittings are generally packed in cardboard boxes, plastic bags or in shrink-wrapped form.

Storage of loose pipes on site

Pipe bundles may be stacked up to three high on firm level ground ensuring that the frames are placed 'wood to wood' to avoid damaging the pipes. Pipes should not be removed from any position within stacked bundles. Before removing pipes the bundles should be placed at ground level and provision made to retain the frames in an upright position as pipes are removed. Although Marley Quantum pipes have a corrugated external profile their unique design allows them to be easily slid out without the corrugations interlocking.

Pipes which have been delivered loose or have been removed from pre-packed bundles should

be stored on a reasonably flat, level surface on timber battens not less than 75mm wide spaced at a maximum of 1m centres. Side support should also be provided at intervals not exceeding 1.5m.

Pipes of different sizes should preferably be stacked separately but where this is not possible larger diameter pipes should be placed at the bottom. Spigot and socket pipes should be stacked with sockets at alternate ends protruding to ensure pipes are evenly supported over their length.

Pipes stored in the open for long periods or exposed to strong sunlight should be covered with an opaque sheet (not black). Fittings supplied in cardboard boxes or polythene bags should be stored in a cool place out of direct sunlight and away from any heat source.

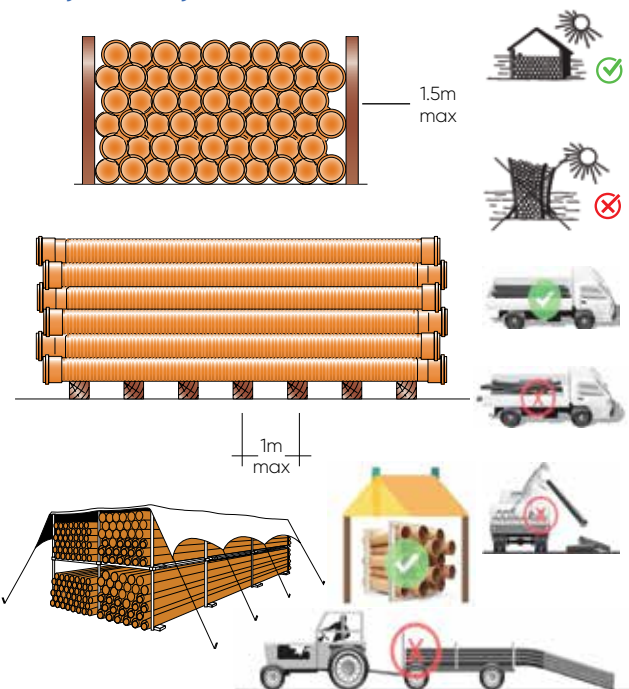

Solid wall pipes

Size	Pipes per Bundle
110mm	100
160mm	46

Regional Registrations Approvals & Certifications

MEP SUPPLIER REGISTRATION CERTIFICATE

ADCE
 المعهد القطري للمهندسين المعماريين
 Abu Dhabi Commercial Engineering Service

Issue Date: 10 November 2025

We hereby register the Supplier: **Vivasvaan Industrial Co**

ADCE Vendor Code: v0003912

Please refer Schedule A for Materials

Remarks:

Suhail Alami
 Registration Review Committee Signature 1

Muhammad Husein Al-Ramahi
 Registration Review Committee Signature 2

Disclaimer:
 1) In the role of the Consultant to select materials from the registered list.
 2) The specifications of the selected materials are the sole responsibility of the Consultant.
 3) Issuing of this Registration Certificate absolves the Supplier or the Consultant from any liability towards any party. ADCE does not make any warranty or representation as to the quality, fitness for purpose, or suitability of the Materials and shall not be liable to any party for any loss including but not limited to the financial condition of the Supplier, the performance and compliance by the Supplier or the Consultant of any contract or agreement, or the accuracy of any statements made by the Supplier or the Consultant. Any representations or warranties made by us are disclaimed. The issuing of this certificate does not confer any authority upon the Supplier or the Consultant.
 4) This certificate is valid for one year from issue date.

Page 1 of 2

MEP SUPPLIER REGISTRATION CERTIFICATE

ADCE
 المعهد القطري للمهندسين المعماريين
 Abu Dhabi Commercial Engineering Service

ADCE Vendor Code: v0003912

Schedule A

ADCE

UPVC & PVC Pipes & Fittings & Accessories - Marley - UAE
 UPVC & PVC Pipes & Fittings & Accessories - Propipe - UAE
 ABS Pipes & Fittings - Marley - UAE
 PPR-R Pipes & Fittings - Propipe - UAE
 PVC Conduits & Accessories - Marshall Tufflex - UAE
 Cable Trays/Ladders and Accessories - Marshall Tufflex - UK
 Cable Management System & Floor Boxes system - Marshall Tufflex - UK

Page 2 of 2

QIC
 شركة قطر للتأمين
 Qatar Insurance Company

CERTIFICATE OF INSURANCE - PUBLIC & PRODUCT LIABILITY

This is to Certify that **Qatar Insurance Company** has issued to the Insured named herein the policy of insurance which provides cover subject to the insuring agreements, limitations, exclusions, conditions and declarations contained therein and during its effective period of coverage as stated below.

POLICY REFERENCE NO. : Q225200704004190

POLICY TYPE : Public & Product Liability – Annual Cover

INSURED : Vivasvaan Industrial Co. - Sole Proprietorship L.L.C.

PERIOD OF INSURANCE : 12 months as from November 21, 2025 to November 20, 2026 (Both days Inclusive)

LIMIT OF INDEMNITY : AED 10,000,000/- any one occurrence and in the aggregate

TERRITORIAL LIMITS : Worldwide Excluding USA & Canada

JURISDICTION : Worldwide Excluding USA & Canada

TERMS & CONDITIONS : All as per Qatar Insurance Company's Policy (Ref Number Q225200704004190)

This certificate is issued as evidence that insurance has been effected as per our Standard Policy Wording and does not purport to show full terms and conditions of coverage nor vary them in any way. The terms and conditions of the insurance policy shall prevail in the event of any inconsistency between this certificate and the insurance policy.

For & on behalf of Qatar Insurance Company



Authorized Signatory

Place: Dubai || Date 26.11.2025

ص ب: ٤٠٦٦ ، دبي ، ا.ع.م. تليفون: ٢٢٢٤٠٤٥ (+٩٧١ ٤) ، فاكس: ٢٢٢٨٩٧٤ (+٩٧١ ٤) البريد الإلكتروني: qicdubai@qicuae.com
 P.O. Box : 4066, Dubai, U.A.E. Tel.: (+971 4) 2224045, Fax : (+971 4) 2238974, E-mail : qicdubai@qicuae.com
 مرسوم بقانون اتحادي رقم ٤٨ لسنة ٢٠٢٣ في شأن تنظيم أنشطة التأمين (م) Federal Decree-Law No. (48) of 2023 Regulating Insurance Activities



Project References



Project : SO/ Uptown Dubai Hotel & Residences
 MEP Consultant : WSP
 MEP Contractor : Voltas Limited
 Location : Dubai, UAE
 Year : 2023



Project : ELITZ 1 Tower by Danube
 MEP Consultant : Al Khawaja Engineering Consultancy
 MEP Contractor : EMAC Electromechanical LLC
 Location : Dubai, UAE
 Year : 2024



Project : Petalz by Danube
 MEP Consultant : National Engineering Bureau: NEB
 MEP Contractor : Al Andalus Power Electromechanical Works LLC
 Location : Dubai, UAE
 Year : 2024



Project : Luce (2B+G+9+R) Residential Building
 MEP Consultant : MZ Architects
 MEP Contractor : Al Ashram Contracting LLC
 Location : Dubai, UAE
 Year : 2024



Project : Upper House West By Ellington Properties
 MEP Consultant : Samadhin Associates Consulting Engineers
 MEP Contractor : International Electro Mechanical Services Co. L.L.C
 Location : Dubai, UAE
 Year : 2024



Project : Skyhills Residences
 MEP Consultant : QHC
 MEP Contractor : Al Andalus Power Electromechanical Works LLC
 Location : Dubai, UAE
 Year : 2024



Project : Viewz 2 by Danube Commercial & Residential Building
 MEP Consultant : National Engineering Bureau
 MEP Contractor : Al Andalus Power Electromechanical LLC
 Location : Dubai, UAE
 Year : 2024



Project : Al Mamshah Seerah Residential Phase 1
 MEP Consultant : Mimar Architecture & Engineering
 MEP Contractor : E7M Electromechanical Works Contracting LLC
 Location : Sharjah, UAE
 Year : 2024



Project : The Residence by Prestige One
 MEP Consultant : Model Engineering Consultants
 MEP Contractor : ANJ Expert Electromechanical LLC
 Location : Dubai, UAE
 Year : 2025



Project : Residential Building At Plot C33 Yas Island
 MEP Consultant : Khatib & Alami and Partners Consulting Architects & Engineers
 MEP Contractor : Anson Construction L.L.C
 Location : Abu Dhabi, UAE
 Year : 2025



Project : Hayyan Villas Arim 2
 MEP Consultant : Al Wasl Al Jadeed Consultants (AWAJ)
 MEP Contractor : Anson Construction L.L.C.
 Location : Sharjah, UAE
 Year : 2025



Project : Saba-4 Tower
 MEP Consultant : LACASA Architects & Engineering Consultants
 MEP Contractor : Prime Star Electrical And Mechanical Works LLC
 Location : JLT-Dubai, UAE
 Year : 2025

Project References



Project : DG1- Residential Tower
 MEP Consultant : Arif & Bintook Consulting
 MEP Contractor : Anwar Al Aqsa Elect. & Sanitary Works LLC
 Location : Dubai, UAE
 Year : 2025



Project : Palm Flower
 MEP Consultant : Arup Gulf LTD
 MEP Contractor : I Zone Electromechanical Contractos LLC
 Location : Dubai, UAE
 Year : 2025



Project : Oceano by Luxe
 MEP Consultant : Dewan Architects & Engineers
 MEP Contractor : I Zone Electromechanical Contractors LLC
 Location : Ras Al Khaimah, UAE
 Year : 2025



Project : Eden House – The Park
 MEP Consultant : Erga Progress Engineering Consultants
 MEP Contractor : Bilt Middle East (MEP Division of Al Basti & Muktha Group)
 Location : Al Wasl, Dubai, UAE
 Year : 2025



Project : Dubai Harbour Residences by Shama Holding
 MEP Consultant : SSH Design
 MEP Contractor : Khansaheb MEP
 Location : Dubai Harbour Zone 4, Dubai, UAE
 Year : 2025



Project : DMCC Uptown Phase 2 T3 & T4
 MEP Consultant : Samadhin+ Associates Consulting Engineers
 MEP Contractor : Menasco Mechanical Contracting Co LLC
 Location : First Al Khail Street, Dubai, UAE
 Year : 2025



Project : Canal Residential Project
 MEP Consultant : Dewan Architects & Engineers
 MEP Contractor : IZone Electromechanical Contractors L.L.C
 Location : Al Wasl, Dubai, UAE
 Year : 2025



Project : Tonino Lamborghini Residence
 MEP Consultant : Delta Engineering Consultants
 MEP Contractor : Mirage Electromechanical Contracting L.L.C
 Location : Nad Al Sheba, Dubai, UAE
 Year : 2025



Project : The Hub Residences
 MEP Consultant : Kaizen Architects & Engineers
 MEP Contractor : Gamma Contracting LLC
 Location : Al Furjan, UAE
 Year : 2025



Project : Commercial & Residential Building
 MEP Consultant : Eng. Adnan Saffarini LLC
 Architects & Engineering Consultant
 MEP Contractor : Grans Electromechanical LLC
 Location : International City, Dubai, UAE
 Year : 2025



Project : Moe The Hangout
 MEP Consultant : WSP
 MEP Contractor : BK Gulf LLC
 Location : Nad Al Sheba, Dubai, UAE
 Year : 2025



Project : 213 Housing Units at Makan in Hatta
 MEP Consultant : Al Turath Al Aseel Contracting LLC
 MEP Contractor : Parsons / Al Turath Engineering Consultant
 Location : Hatta, Dubai, UAE
 Year : 2025

PVC Drainage and Sewage Systems

REDI



Acoustic Soil & Waste System

dB blue



HDPE Soil & Waste System

akatherm



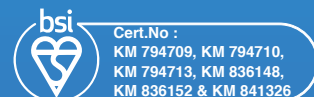

A5 | Building No.11 | KEZAD
P.O. Box 93180 | Abu Dhabi
United Arab Emirates

T +971 2 675 2233
E sales@marleysoilwaste.com
www.marleysoilwaste.com



Factory Video



Catalogue & Technical Manual



Kite Mark Certificates