

GENERAL NOTES.

1. NO SHARP EDGES - BREAK ALL EDGES PRIOR TO FABRICATION.
2. SEAL WELD ALL OPEN JOINTS

ROUND EDGES
TYP. ALL

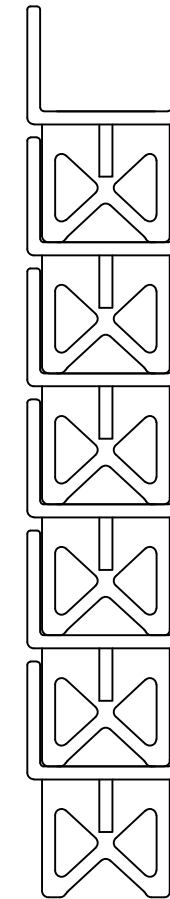
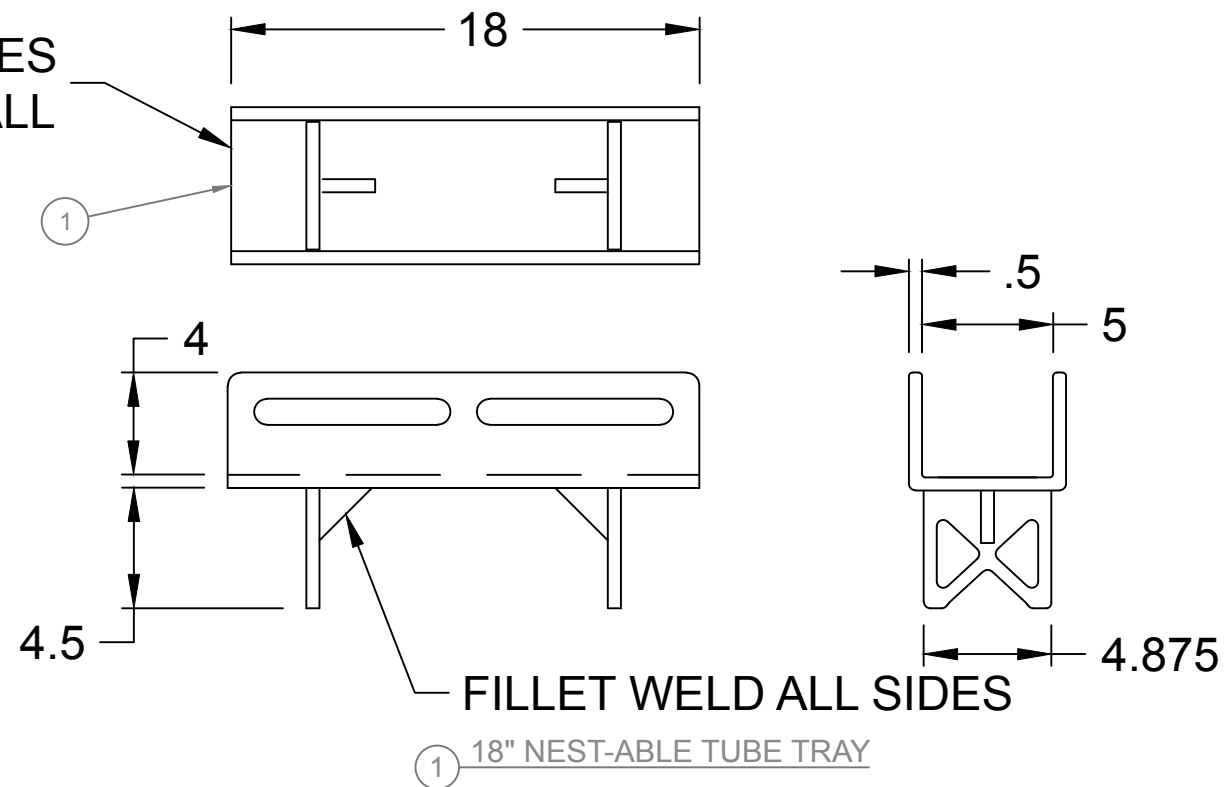

Bill of Materials

Item	Description	Quantity	Part Number
1	NEST-ABLE-LINKABLE TUBE TRAY - $\frac{1}{2}$ " HIGH DENSITY POLYETHYLENE SHEET	1	

Customer Design Approval

Customer:	Name:	Sign:	Date:
-----------	-------	-------	-------

Design Approval - This drawing has been created based upon interpretation of customer specifications and user requirements. The customer assumes full responsibility that the design depicted herein meets the customer requirements and signature indicates acceptance of responsibility and approval of design to manufacture.



275 Grove Street Suite 2-400
Auburndale, MA 02466
www.pharma-techs.com

Project: NESTABLE TUBE TRAY
 Drawn By: RG
 Chk'd By: BD
 Date: 05MAR18
 File Name: TUBE TRAY.DWG
 Dwg. No: 01311802 Rev. No: 01

This drawing contains information considered to be confidential to Pharma-Tech. This drawing shall not be shared with any third party or reproduced in any form without expressed written approval from Pharma-Tech.