

# Morning Star Elevator CARLOFT

The **CARLOFT™** system enables vehicles to be stored in the otherwise unused attic or loft space above conventional garage bays. No longer are traditional lifts needed that mount to the floor of the garage and take up space. You get your surface space back and never have to pull under a vehicle lift again. The **CARLOFT™** can be designed into new construction, and with careful planning and execution may be retrofitted into existing homes. This system is available in a variety of standard garage configurations with dimensions that can be configured to the individual project.



INNOVATIVE VEHICLE STORAGE FOR PRIVATE RESIDENCES

## FEATURES

- Available in two, three, and four bay custom configured systems
- Uniquely configured to each individual garage
- Utilizes a steel beam structure stretched into the 4 corners of the garage space
- Vertical beams are hidden behind garage door divisions and corners of the garage
- 100% hot-dipped galvanized steel structure and platforms
- Suspended platforms lift vehicles into the available overhead loft/attic space
- All electric motors, no hydraulics
- Can be retro-fit into existing garages
- Lifted platforms can be configured to 7, 8, 9, even 10 feet overhead, leaving the garage floor surface clean, uncluttered
- Ideal for storing ATVs, motorcycles, golf carts, etc.
- Vehicles that are driven daily can be pulled in and out of the garage without having to navigate around steel posts and platforms
- Platforms made of 100% galvanized steel
- Anti-fall devices are integrated into every platform
- Upper and lower limit switches to ensure platform settings and placement
- Photo beams to detect when a car is in the lower space eliminating the risk of lowering any upper platforms onto a lower parked vehicle (optional)
- 220V Single Phase Power
- Key pad operated controls

## SAFETY

- Key-operated control switch for security and safety
- Automatic shut-off if operator releases the key-switch
- Structure certified for seismic and wind loads
- Integrated anti-fall safety system
- Manually operated lock releases
- All platforms configured with wheel stops and centering guides

## WARRANTY

- (1) One Year Electrical
- (2) Two Year Mechanical
- (4) Four Year Structural



CONTACT US FOR A FREE CONSULTATION (303) 623-7433

# CARLOFT CONFIGURATIONS

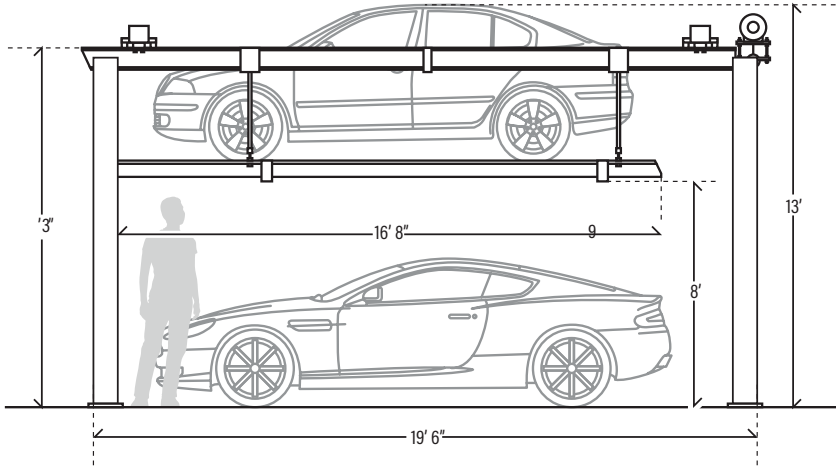

Typical dimensioning for the CARLOFT. Dimension can be modified to fit the garage design  
This is based on one car above and one car at grade. \*Average vehicle length is 16' 6".

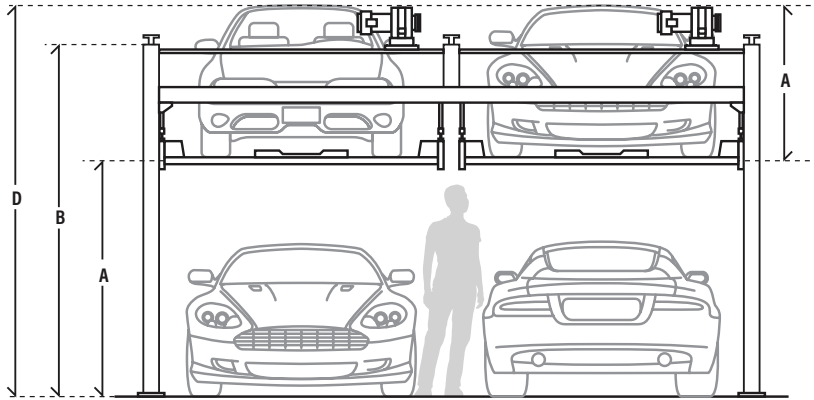

TOTAL REQUIRED CEILING HEIGHT CLEARANCE TOOL		Preferred Overhead Clearance (inches)						
MAX UPPER VEHICLE HEIGHT	60	132	138	144	150	156	168	
	66	138	144	150	156	162	174	
	72	144	150	156	162	168	180	
	78	150	156	162	168	174	186	

- A - Distance from the Floor to the Bottom of the Upper Platform
- B - Distance from the Floor to the Top of the Vertical Post
- C - Height of the Upper Car
- D - Distance from the Floor to the Top of the Upper Car

Typical Configuration: D= 13 Feet A= 8 Feet C= 5 Feet B= 9.25 Feet

# PLAN VIEW ONFIGURATIONS

