

**Vasari**  
INSPIRED PARKING

 MORNING STAR ELEVATOR

(303) 623-7433

# Vasari Parking Lifts Application Guidelines for Subterranean Four Post Models



**Vasari-Lifts.com**

Denver Metro 720.881.2692 • Colorado Springs 719.635.7960 • Glenwood Springs 970.384.2212

© 2018 AUTOQUIP CORPORATION

This guideline and the information herein is the sole property of Autoquip Corp. and shall not be reproduced without written consent by Autoquip

# TABLE OF CONTENTS

- 1. Foreword**
  - 2. Scope and Purpose**
    - 2.1 Intent
    - 2.2 Equipment Not Covered
    - 2.3 Purpose
  - 3. Lift Duty & Code Compliance**
  - 4. Terms & Definitions**
  - 5. Subterranean Lift Applications**
    - 5.1 Areas of Use
    - 5.2 Types of Use
  - 6. Lift Types & Configurations**
    - 6.1 4-Post, Hydraulic Style
    - 6.2 4-Post, Mechanical Style
  - 7. Specification Considerations**
    - 7.1 Vertical Travel
    - 7.2 Floor to Floor Distance
    - 7.3 Capacity, Size & Type of Load
    - 7.4 Traffic Pattern
    - 7.5 Axle Loads
    - 7.6 Electrical Considerations
    - 7.7 Operating Considerations
    - 7.8 Guarding the Lift Operating Zone
    - 7.9 Power Unit/Drive Types
    - 7.10 Platform Attachments
  - 8. Standard Lift Features**
    - 8.1 Standard Specifications
  - 9. Installation Considerations**
    - 9.1 Pre-Planning
    - 9.2 Subterranean Pit
    - 9.3 Lift Operating Zone
    - 9.4 Vertical Guide Angles
    - 9.5 Utility Room/Area
    - 9.6 Ship-Loose Electrical Components
    - 9.7 Electrical Installation Notes
  - 10. Lift Safety**
    - 10.1 Safety Labels
    - 10.2 Safety Features (non-electrical)
  - 11. Shipping & Handling**
    - 11.1 Typical Component Weights
  - 12. Start-Up Testing**
  - 13. Maintenance Schedule**
    - 13.1 Each Month
    - 13.2 Every Six Months
    - 13.3 Once Per Year
- Limited Warranty**

## 1. FOREWORD

This Application Guidelines for Subterranean Parking Lifts (Guidelines) was developed by Autoquip and the descriptions, specifications and guidelines herein are believed to represent the Industry's best practices. The Guidelines present recommended safety practices for subterranean parking lifts as well as information for parties engaged in the marketing, purchase, inspection or use of residential subterranean parking lifts. The Guidelines are advisory only and should be regarded as a guide that the user may or may not choose to adopt, modify or reject. They were developed with the sole intent of offering information to parties engaged in the marketing, purchase or use of these lifts.

As of this date, there is no recognized equipment standard specific to residential subterranean parking lifts. Therefore, it is the intent of these Guidelines to provide information to the users and operators of various residential parking lift designs with respect to safe application and proper utilization of these lifts. The acceptance or use of these Guidelines is completely voluntary.

## 2. SCOPE and PURPOSE

2.1 **Intent.** This Application Guideline is intended to specifically apply to Subterranean Residential Parking Lifts which are designed to raise and lower vehicles from one elevation to another within a residence. They are primarily hydraulically or electro-mechanically activated and powered. These lifts are mounted in a stationary position.

2.2 **Equipment Not Covered.** This Application Guideline does not relate to :

- a) Vehicle Maintenance Lifts as covered by ANSI/ALI ALCTV.
- b) Vehicle Elevators of any type as covered in ANSI/ASME A17.1
- c) Surface-mounted parking lifts not placed within a subterranean pit/vault
- d) Any lift designed to transport personnel
- e) Lifts for handicapped access as described by ANSI/ASME A18

2.3 **Purpose.** The purpose of this Application Guideline is to provide architects, contractors, designers, sellers, installers, owners, users and governing bodies with a source of information for consideration in design, application, and configuration criteria.

### 3. LIFT DUTY & CODE COMPLIANCE

- 3.1 Parking Lifts are not vehicle elevators and do not meet the requirements of ASME A17.1 – *Safety Code for Elevators and Escalators*. At no time should these lifts be used to transport people.
- 3.2 Parking Lifts are not vehicle maintenance lifts and do not meet the requirements of ANSI/ALI ALCTV:2006 – *Safety Requirements for Automotive Lifts*. Under no circumstances should a person get under the lift without it being safely blocked open per the procedure in the Service Manual.
- 3.3 Subterranean parking lifts designed to accommodate personal vehicles with normal axle loads and weight distributions for such. Standard parking lifts are not designed to withstand single axle loads greater than 4,000 lbs. at the front edge of the lift or a weight distribution that exceeds more than a 60/40 difference in total vehicle weight from front to back.
- 3.4 Each state, county, or municipality may have unique codes governing the installation and acceptance of residential parking lifts. Acquaint yourself with the permitting and/or licensing requirements (and expenses) of the local regulatory agencies.
- 3.5 Residential subterranean parking lifts should meet the applicable portions of the following nationally recognized safety standards:
  - a) ANSI Z535.4 Standard for Product Safety Signs & Labels
  - b) ASME A52 Structural Steel Standard
  - c) AWS B2.1/B2.1M Welding Qualification Standard
  - d) NFPA/NEC National Electric Code
  - e) OSHA 29CFR1910 General Industry Safety Regulations
  - f) ANSI MH29.1 Safety Requirements for Industrial Scissors Lifts
- 3.6 Residential subterranean parking lifts' system control panel is designed, manufactured and labeled per Canadian and US standards (cULus) as defined by Underwriters' Laboratories. All other electrical devices are UL and CSA approved and labeled.
- 3.7 Subterranean parking lifts are designed to raise loads placed on the lower platform and only when specifically rated, on the canopy.

## 4. Terms & Definitions

**Approach Ramp:** An access ramp used to load vehicles on/off of a platform, typically when the carriage comes to rest above the landing elevation.

**Authorized Person:** Trained or qualified personnel approved or assigned to perform a specific duty or duties.

**Capacity:** The maximum load which the lift is designed to raise and lower.

**Canopy:** The upper platform assembly that travels above the uppermost landing when the lift is raised, and lowers into a recess/opening in the upper landing floor when lowered.

**Carriage:** The lower platform assembly that travels in the guide angles and carries the vehicle between landings.

**Constant Pressure Push Button:** A push button which, to activate, must remain pressed by the operator in order to perform a desired operation.

**Controls:** Any electrical device used to initiate or stop lift movement. Normally includes push button stations, control box, limit switches, interlocks, etc.

**Control Voltage:** The secondary voltage, which typically originates at a transformer and provides power to the control devices.

**Cylinder (Ram):** A device which converts fluid power into linear force and motion. It consists of a solid ram operating within a cylindrical barrel or casing.

**Drift:** The distance a lift platform will slowly drop due (usually) to slight internal leaks in a hydraulic system or mechanical slippage of a motor brake.

**Enclosure (lift guarding):** Structure surrounding the lift operating zone to prevent outside interference with its normal operation and to safe guard personnel.

**Flow Control:** A hydraulic component that allows a constant volume of fluid to pass through an orifice in a controlled, predictable manner.

**Gate:** A device that opens and closes manually or automatically to allow access to the lift operating zone. It is normally a swing, sliding, or vertical acting device constructed of rigid material.

**Grade Level:** Level at which vehicles enter and exit street level.

**Hydraulic piping system:** The entire system of fluid conductors such as hose, pipe, tubing, etc., utilized to transfer hydraulic fluid between various operating components of a hydraulic system such as pumps, valves, actuators, etc.

**Landing:** A permanent-working surface at a fixed elevation used for loading and/or unloading a vehicle.

**Landing interlock:** A device to prevent lift movement when a landing door/gate into the lift operating zone is not fully closed, and to prevent the landing door/gate from being opened while the lift is in motion.

**Lift Operating Zone:** The space directly above and directly beneath the lift's parking surfaces, from the lowermost floor to the uppermost ceiling, as well as the areas immediately surrounding the perimeter of this space

**Limit Switch:** An electrical control device by which the position or movement of the lift may be controlled within predetermined limits.

**Guide Angles:** The structural steel members which guide the carriage throughout its vertical travel.

**Mechanical Stop:** A means to physically stop travel at a predetermined position.

**Momentary Contact Push Button:** A push button which is pressed and released by the operator to activate the desired operation.

**Operator:** An authorized person controlling the movement of the parking lift.

**Owner:** A person or entity that has possession and control of the parking lift by virtue of title to the equipment.

**Platform:** The deck surface of the carriage/canopy on which the vehicle is parked.

**Pressure Switch:** An adjustable pressure sensing switch that, when made, sends an electrical signal to the control circuit to stop the pump/motor.



**Primary Voltage:** The main electrical power being supplied to run the motor.

**Push Button Station:** The wall mounted or hand held device used by the operator to control the operation of the equipment.

**Qualified Person:** A person, who by possession of skill, knowledge, training and experience has demonstrated the ability to address problems related to the lift.

**Secondary Voltage:** See **Control Voltage**.

**Spliced Carriage:** Carriage that is in multiple pieces and will be field assembled. This design facilitates ease of installation and handling.

**Velocity Fuse:** A hydraulic valve, which in the event of a severed hose, will lock the oil in the cylinder and prevent the cylinder from descending.

## 5. SUBTERRANEAN LIFT APPLICATIONS

### 5.1 AREAS OF USE

5.1.1 **Indoor/Garage.** Most residential vehicle parking applications are under the roof of an attached or detached garage and not exposed to the elements of weather.

5.1.2 **Outdoor/Driveway.** Some residential vehicle parking applications are outdoor applications requiring a special lift design to accommodate the potential effects of wind, rain, snow & ice, etc..

5.1.3 **Vehicle Vaults.** A vault application is one where no access to the lift is provided at the lower landing, accessibility to the lift and its components are from the upper landing only. This is common when the primary purpose of the subterranean lift is to provide security for the vehicle.

5.1.4 **Two Landings.** Most common. Vertical transfer of vehicles is done between two fixed elevations/landings. This is normally between the garage and basement landings, but can also be between the garage and attic landings.

5.1.5 **Three Landings.** Less common. Vertical transfer of vehicles is done between three fixed elevations/landings. However, most hydraulic

control systems do not provide accurate stopping position repeatability under both loaded and unloaded conditions. Again, the application can either have the garage as the uppermost or lowermost landing.

## 5.2 TYPES OF USE

- 5.2.1 **Vehicle Parking.** One of the primary motivations behind the specification and use of subterranean parking lifts is to take advantage of the vertical space available between upper and lower landings to provide additional parking space without expanding the square footage of the home/building to do so – for the storage of cars, trucks, boats, jet-skis, ATVs, golf carts, and other recreational vehicles or watercraft.
- 5.2.2 **Vehicle Display.** In addition to expanding vehicle parking space by storing vehicles below or above garage level, many owners choose to raise or lower their prized possessions into enhanced viewing space (special lighting, background, etc.).
- 5.2.3 **Vehicle Transport/Motor Court.** When the architectural plan allows, expanded square footage for parking can be provided at elevations below or above the main garage level, and the subterranean lift is used to transport vehicles between elevations where they are driven off the lift and parked adjacent to the lift operating zone.
- 5.2.4 **Vehicle Security.** One primary motivation for installing a subterranean parking lift is to be able to provide a safe and secure parking location below grade for prized vehicles – to better protect them against theft or vandalism, and to prevent unauthorized access to them (as in the case of time-shared properties, etc.).
- 5.2.5 **Material Transfer.** Not only can subterranean lifts be used to transport and park vehicles and watercraft, but the lower carriage can also be used as a material lift to transport bulky or heavy items such as boxes, files, furniture, powered tools, Christmas trees, etc. between grade level and attic/basement landings. **NOTE:** Due to potential load instability & falling objects, do not use the top canopy to transfer vehicles or material.

## 6. LIFT TYPES & CONFIGURATIONS

## 6.1 Four Post, Hydraulic Style – Fixed Canopy & Sliding Canopy

6.1.1 **Design Approach.** Carriage and canopy platforms are actuated by four vertical hydraulic ram cylinders which raise and lower the lift platforms within four vertical guide angles attached to the building structure. Lifting cylinders are mounted vertically between the lower carriage and upper canopy. The stroke of the cylinders equals the vertical distance between lower and upper landings (i.e. the “travel” of the lift).

6.1.1.1 Fixed Canopy. Single-stage cylinders are used when the overhead clearance at the upper level (typically the garage ceiling) is equal to, or greater than, the vertical travel distance between the upper and lower landings. Canopy posts are fixed height and field-attached between the carriage and canopy.

6.1.1.2 Sliding Canopy. Telescoping cylinders are specified when the overhead clearance at the upper level (typically the garage ceiling) is less than the vertical travel distance between the upper and lower landings. Canopy posts are full height and slide through the lower carriage, canopy is picked up by the carriage via physical stops that are field-located and welded to the posts to ensure that the canopy remains within the allowable overhead clearance.

6.1.2 **Synchronization.** The lifting cylinders are synchronized to ensure that the four corners of the lift travel at the same pace and thereby keep the lift level throughout its vertical travel – regardless of the weight distribution of the load. This synchronization is accomplished using one of two methodologies:

6.1.2.1 Mechanically Synchronized – by a series of chains and sprockets located beneath the lower carriage which physically capture the structure of the carriage and force the four corners to travel together.

6.1.2.2 Hydraulically Synchronized – by using a highly accurate fluid metering system to keep the four cylinders stroking at the exact same rate.

6.1.3 **Advantages.** The advantages of the four post hydraulic design are: 1) cylinders are accessed easily from above the carriage platform, 2) more structurally stable as vehicle axles roll over the edge of the lift, 3) 18” of refuge space beneath the entire lift – for access & personnel safety, 4)

faster standard speeds – because of the vertically mounted cylinders, 5) no lift component weight over 3500 lbs – and can accommodate travels from 7 to 12 feet with no difference in overall lift weight, and 6) lower component stresses in the structure of the lift assembly.

6.1.4 **Disadvantages.** The primary disadvantages of the four post single stage design are: 1) requires structural support from the surrounding building (i.e. is not free-standing), and 2) slightly more expensive to install because of the multiple ship-loose components of the lift.

## 6.2 Four Post, Mechanical Style – Fixed Canopy & Sliding Canopy

6.2.1 **Design Approach.** Carriage and canopy platforms are actuated by two rigid chain systems which raise and lower the lift platforms within four vertical guide angles attached to the building structure. Lifting cylinders are mounted vertically between the lower carriage and upper canopy. The stroke of the cylinders equals the vertical distance between lower and upper landings (i.e. the “travel” of the lift).

6.2.1.1 Fixed Canopy. Fixed-height canopy posts are attached between the carriage and canopy when the overhead clearance at the upper level (typically the garage ceiling) is equal to, or greater than, the vertical travel distance between the upper and lower landings.

6.2.1.2 Sliding Canopy. Sliding canopies are specified when the overhead clearance at the upper level (typically the garage ceiling) is less than the vertical travel distance between the upper and lower landings. Canopy posts are full height and slide through the lower carriage, canopy is picked up by the carriage via physical stops that are field-located and welded to the posts to ensure that the canopy remains within the allowable overhead clearance.

6.2.2 **Synchronization.** Due to the synchronized actuation of the two lifting chains by a common drive motor, the lift remains level throughout the lift travel.

6.2.3 **Advantages.** The advantages of the four post mechanical design are: 1) inherent synchronization, programmability, and accuracy of mechanical actuation, 2) 18” of refuge space beneath the entire lift – for access & personnel safety, 3) variable speeds – with the addition of a variable

frequency drive (VFD) option, 4) no lift component weight over 3500 lbs – and can accommodate travels from 7 to 20 feet with no difference in overall lift weight, and 5) lower component stresses in the structure of the lift assembly.

6.2.4 **Disadvantages.** The primary disadvantages of the four post mechanical design are: 1) requires structural support from the surrounding building (i.e. is not free-standing), and 2) slightly more expensive to install because of the multiple ship-loose components of the lift.

## 7. LIFT SPECIFICATION CONSIDERATIONS

7.1 **Vertical Travel.** The difference in elevation between the top surface of the carriage at the bottommost level and the top surface of the carriage at the uppermost level – regardless of whether the unit is pit or surface mounted.

7.2 **Floor-to-Floor Distance.** The distance from one finished floor level to the next finished floor level.

7.3 **Capacity, Size and Type of load.** Capacity not only refers to the weight of the load but also the physical size and configuration of the load. Types of loads are typically: cars, trucks, trailers, motorcycles, large boxes, powered carts, etc. The platform should be sized to handle the largest loads with adequate clearances for entering and leaving the carriage. The capacity should also take in consideration any dead (non-moving) weight such as material added to the parking decks (concrete, brick pavers, etc.), and the weight of any equipment used for loading and unloading objects (i.e. fork trucks, powered pallet trucks, etc.).

7.4 **Traffic Pattern.** The traffic pattern of vehicles entering and exiting the lift are critical to determining: 1) necessary clearances between canopy posts, 2) the need for approach ramps (for surface-mounted lifts), and 3) the design and layout of lift guarding (doors, gates, enclosures, barriers, etc.)

7.5 **Axle Loads.** Consideration must be given to a vehicle's axle weight as it rolls across the edge of the platform when entering & exiting the lift. Standard units assume that maximum disparity in axle weights between front and rear axles is a

60-40 split in total vehicle weight. The manufacturer must be made aware of any axle weights that exceed this.

**7.6 Electrical Considerations.** The following should be considered:

- 7.6.1 The availability of up to 50 amp service for high speed, 230V-1phase motors.
- 7.6.2 Severe operating conditions, such as outdoor applications, often require special electrical components.
- 7.6.3 There is considerable field wiring to be done to connect all the peripheral electrical signaling devices to the main motor control panel.

**7.7 Operating Considerations.** The following should be considered:

- 7.7.1 Optional vehicle location sensors/devices are available to ensure that the entire vehicle is within the area of the platform prior to raising or lowering the lift.
- 7.7.2 Optional sensors are available to ensure that a vehicle is not parked on the top canopy prior to the lift being raised.
- 7.7.3 Optional lift finishes are available – to better combat the effects of severe operating conditions such as salt water, ice/snow, etc.
- 7.7.4 Optional power unit configurations are available to increase the speed of the lift – should that be a major consideration.
- 7.7.5 Additional security against unauthorized use and operation of the lift.

**7.8 Guarding the Lift Operating Zone.** Personnel safety during lift operation is of utmost importance, and some safety features are sold as standard with every lift. Additional, optional, guards, safeties, and restraints are available to prevent inadvertent contact with a moving lift – on both the operating level, and the level that is outside the operator's direct line of sight:

- 7.8.1 **Security Cameras (std).** Security cameras are mounted in the lift operating zone at the level not occupied by the operator. These cameras allow the operator to view the portion of the lift zone that is outside his direct line of sight by watching the monitor mounted adjacent to the pushbutton station.

- 7.8.2 **Audible Alarm (std).** An adjustable audible alarm that sounds off any time the lift is moving, or is left in any position other than the fully raised or fully lowered position, to warn people in the area of lift movement.
- 7.8.3 **Emergency Stop Button (std).** E-Stop stations are mounted in the lift operating zone at the level not occupied by the operator. Pressing this large, red “panic” button removes all power to the lift controls and renders the lift inoperable until the button is manually reset.
- 7.8.4 **Motion Sensors (std).** These sensors are mounted in the lift operating zone at the level not occupied by the operator. Any motion that is detected while the lift is moving automatically disables the operator pushbutton station and stops the lift.
- 7.8.5 **Doors.** It is common for doors, usually fire-rated doors provided by the general contractor, to enter the lift operating zone at both the operating level to and the non-operating level to prevent incidental contact with the lift. It is recommended that the status of these doors be monitored, and interlocked to prevent entry ingress/egress while the lift is moving.
- 7.8.6 **Gates.** The manufacturer can also supply commercial gates, typically at the storage landing, to prevent personnel ingress/egress during lift operation. Gates can be designed to swing, slide, or roll up – depending on the application & architectural features of the floor plan. It is recommended that the status of all gates be monitored, and interlocked.
- 7.8.7 **Enclosures.** In addition to conventional walls which can be constructed around the lift operating zone to prevent access to the lift, the manufacturer can supply commercial/industrial (typically expanded metal) enclosures as personnel barriers.
- 7.8.8 **Status switches.** Door status switches are recommended for all doors leading into the lift operating zone to prevent operation of the lift if a door is in the “open” status. These switches come in a variety of designs, depending on the style door that they are mounted to.
- 7.8.9 **Interlocks.** Door interlocks are also recommended for all doors leading into the lift operating zone to temporarily and automatically place the door into “lock” condition whenever the lift carriage is moving. Interlocks

also come in different designs, including some that are available as a combination status switch and interlock.

**7.8.10 Photo Eye Sensors.** Photo eye sensors can be placed at strategic points around the unprotected/unguarded edges of the lift carriage to detect any interference with people or objects that break the photo eye path. If this path is broken, the lift will immediately be rendered inoperable until the interference is removed.

**7.9 Power Unit/Drive Types.** These fall into two primary categories:

**7.9.1 Hydraulically Driven.** Most subterranean lifts fall into this class because of the overall lower cost to manufacture this type of lifting system. The lift design incorporates four (4) hydraulic rams acting directly on the carriage platform to raise and lower the load. The vertical travel is a 1 to 1 ratio of cylinder stroke to travel.

Lowering of the platform is strictly a function of gravity when the holding valve is opened allowing hydraulic fluid to drain back to the reservoir and lowering speed is controlled by a flow control valve.

**7.9.2 Mechanically Driven.** This is the unit of choice for extremely high travel, applications with 3 or more levels of operation where intermediate stops are required, or where accuracy and/or programmability are critical. This system utilizes an electric gear motor with brake. The carriage is raised from beneath by heavy-duty stacking chain(s). Travel is controlled with an electrical limit switch or similar device at each level. Stopping accuracy is normally good in both loaded and unloaded conditions.

**7.9.3 Sizing a Power Unit.** A lift's power unit should be sized to easily handle its rated working capacity, the lifting speed, and its duty cycle. Include weight of platform-mounted accessories when specifying the rated capacity. Particular attention should be given to hydraulic units operating in abnormally high or low ambient temperatures as oil temperature could affect performance.



#### 7.9.4 Locating the Power Unit or Drive.

7.9.4.1 Hydraulic power units are remotely located in utility rooms/areas to help control noise generated by the single-phase motor, and to improve accessibility for maintenance and repair. Power Units should always be located within 25 feet of the lift, so as not to introduce too much back pressure in the “DOWN” mode when the lift is lowering by gravity under its own weight. **NOTE:** Be aware of any local building codes which may address gasses or fumes in pit areas.

7.9.4.2 A mechanical chain driven unit cannot have the power unit located remotely but the electrical control panel may be mounted remotely within reasonable proximity of the lift thus reducing costs if the operating area is classified as a hazardous area.

7.10 **Platform Attachments.** Accommodations can usually be made to enhance the performance or appearance of the lift by adding optional features to the carriage and/or canopy. In most cases, any additional weight that these features may add to the overall lifting requirement has been taken into account in the rated lifting capacity. Consult the manufacturer to inquire as to whether or not these may cause the lifting capacity to be de-rated by some amount.

7.10.1 **Platform “Lip”.** A permanently welded raised lip or flange around the perimeter of the canopy platform to assist in holding/containing loose material added for aesthetics, such as concrete, dirt/sod, gravel, brick pavers, ceramic tile, etc.

7.10.2 **Platform Stiffeners.** In the event that localized deflection of the canopy deck surface can cause cracking of concrete, tile & grout, etc. which may have been added to the canopy surface, often extra structural steel stiffeners are added beneath the deck plate to inhibit deflection.

7.10.3 **Perimeter Flexible Seals – Canopy Deck.** In wet climates, there may be a concern about water/snow dripping off of vehicles parked on the canopy down to the lower landing. Sealed brushes can be supplied to install around the perimeter of the canopy to produce a weather seal in the ¾” – 1” gap between the lift platform and garage floor opening.

7.10.4 **Platform “Skin”**. Sometimes sheets of material are attached to the either/both deck surfaces for aesthetics or corrosion/wear resistance, such as stainless steel, aluminum, and wood laminate.

7.10.5 **Adjustable Wheel Stops – Either/Both Decks**. These heavy duty wheel stops have a rubber non-skid surface that sits on the steel deck parking surface, and houses two (2) industrial grade magnets that also help to hold the wheel stop in place during contact with the vehicle wheels.



7.10.6 **Maintenance Access Hatch – Canopy Deck**. A maintenance hatch comes standard in the lower carriage deck to be able to access the underside of the lift when the lift is fully lowered. If access to this hatch is limited or removed – as is the case with a vault application where no access to the lift is provided at the lower level – then an additional hatch is placed in the upper canopy deck to be able to access the lower deck from the upper deck/upper landing.

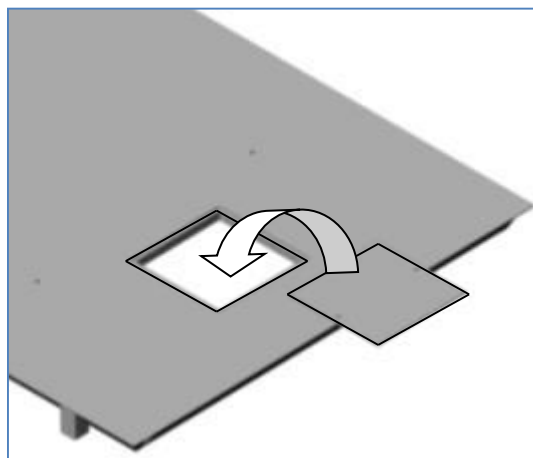

## 8. STANDARD LIFT FEATURES

8.1 **Specifications.** The following represent the features of a “standard” lift:

### General:

- Travel: Maximum of 18’ (telescoping)
- Speed: 6.5 FPM
- Load Capacity: 7,000#
- Overhead: Lift travel + 6”
- Pit depth: 24-1/2”
- Two stops
- Four open sides
- Two year limited warranty on parts
- Ten year warranty on structure

### Mechanical Equipment:

- Upper Canopy deck
- Lower Carriage deck
- (4) Standoff posts
- (4) Guide angles
- (4) #60 roller chains
- (4) lifting cylinders
- 230VAC, 60Hz, 23 amp single phase power supply for 5HP motor controller

### Standard Safety Devices:

- Security key switch station
- Digital security keypad
- Emergency stop station
- Lift-in-motion audible alarm
- Motion detection system
- Wireless camera system
- Push and hold operator pushbutton
- 18” refuge space beneath entire lift
- Beveled toe guard on top canopy
- Hydraulic velocity fuse for free-fall arrest

### Controls:

- Programmable controller
- Self-diagnostic system with digital display
- Manual lowering valve – in case of power failure

### Deck Features:

- 108”W x 216”L standard size

### Optional Features:

- Custom platform sizes
- 10,000# capacity
- Ultrasonic position indicator with lights
- Central Command Center
- Biometric (fingerprint) security scanner
- Door status switch
- Door interlock kit
- Powder Coat finish
- Special paint colors
- Stainless steel deck plate
- Photo-eye interference detection
- Vehicle present photo-eye sensor
- Vehicle present advanced technology sensor
- Lift-in-motion flashing light
- Sensing edge for interference detection
- Pressure-sensing floor mat

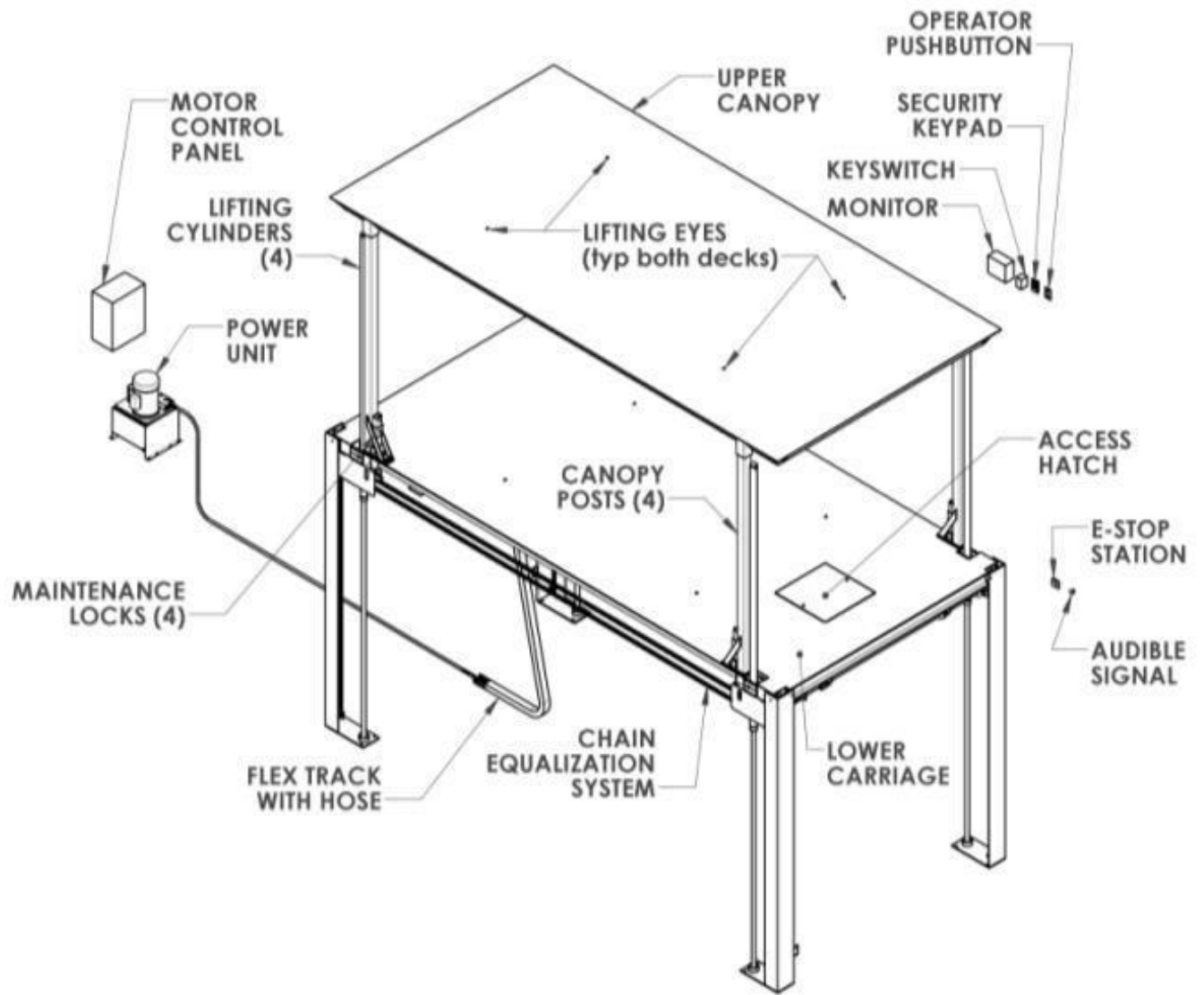

## Component Identification

## 9. INSTALLATION CONSIDERATIONS

9.1 **Pre-Planning.** Whenever possible, make a pre-installation visit or call someone at the site. Installers must be familiar with everything relative to proper installation of this equipment. Some concerns are listed below, though listing every affecting contingency is impossible. It is the installer's responsibility to check the site for problems and work out solutions with the appropriate people. Some of the areas of concern are:

- a) Is the site accessible to large delivery & cartage vehicles?
- b) Can the lift components get through the existing doorways & floor openings?
- c) How will the unit be raised, set into position, and accessed?
- d) Can a chain fall be hooked to an available overhead support?
- e) Is there a forklift or other cartage equipment available?
- f) Is there adequate building structure to support vertical guides?
- g) Look for problem areas such as bracing and overhead interference with ceilings, joists, pipes, etc.

9.2 **Subterranean Pit.** Because the lift guide angles attach to the subterranean pit walls, it is critical that the pit be correct per manufacturer's recommendations and consider the following:

- 9.2.1 Pit floor must be flat and level within  $\frac{1}{2}$ " (plus or minus  $\frac{1}{4}$ ").
- 9.2.2 Pit walls must be straight and plumb within  $\frac{1}{2}$ " (plus or minus  $\frac{1}{4}$ ").
- 9.2.3 Make sure pit is properly squared and vertically aligned with the opening in the garage floor to ensure clearances of at least  $\frac{3}{4}$ " between outside perimeter of lift and inside perimeter of floor opening – follow manufacturer's recommendations as shown on the pit drawing.
- 9.2.4 Provide adequate drainage to pit area to prevent pit from filling with water.
- 9.2.5 Run a 3" diameter PVC pipe with long radius sweep elbows to provide a pipe chase for hydraulic hose from the remote power unit.
- 9.2.6 The pit floor should have sufficient strength to withstand the loads as shown on the manufacturer's approval drawing.
- 9.2.7 The total pit depth should be such that it will allow shimming of the lift landing legs to bring the carriage top surface flush with the lower landing.

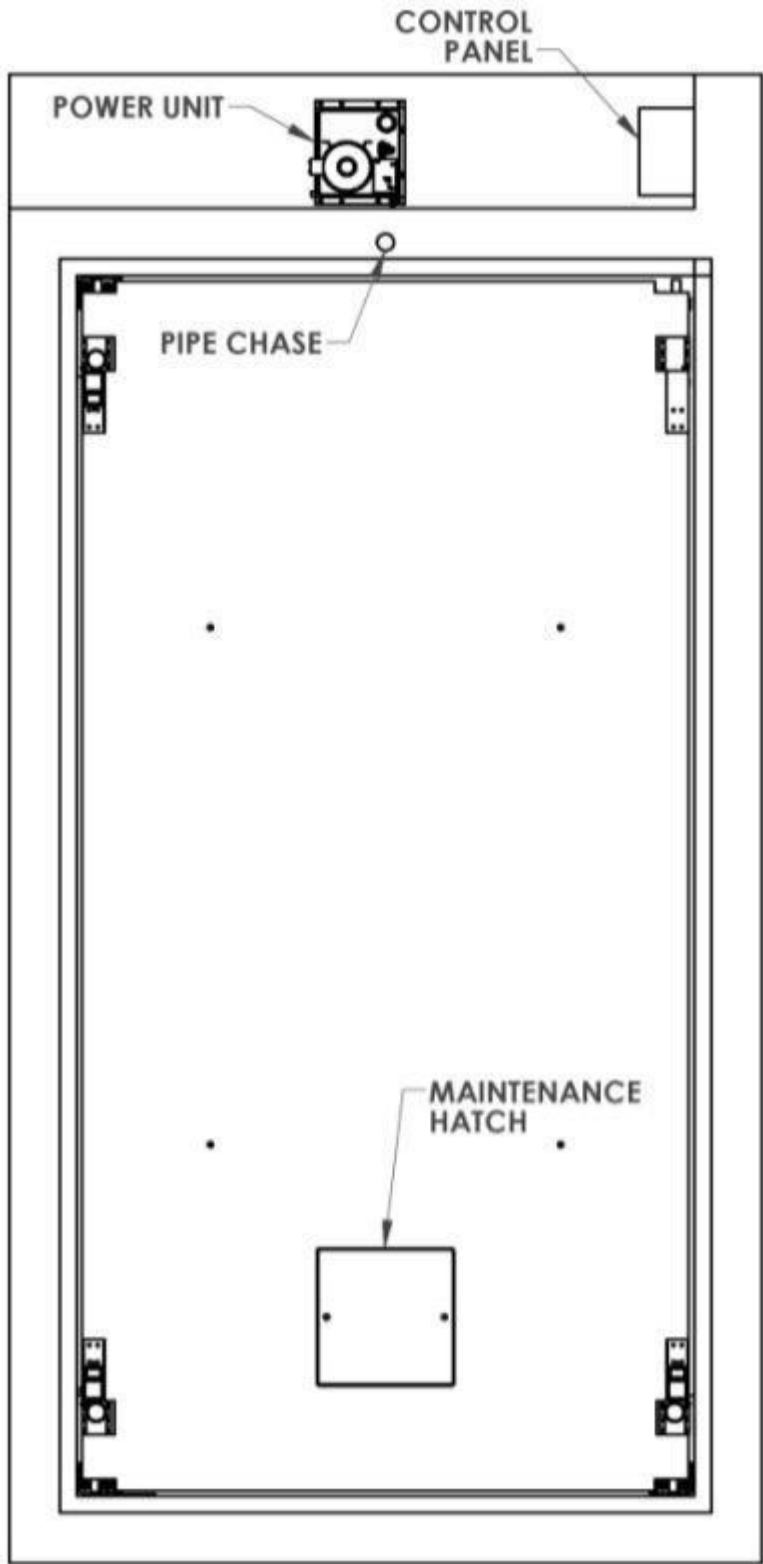

**Top (Plan) View – Subterranean Pit (Lower Level)**

**NOTE:** Maintenance Access Hatch is placed on the opposite end of the lift from the pipe chase & power unit. Otherwise, hose guidance flex track will block access hole.

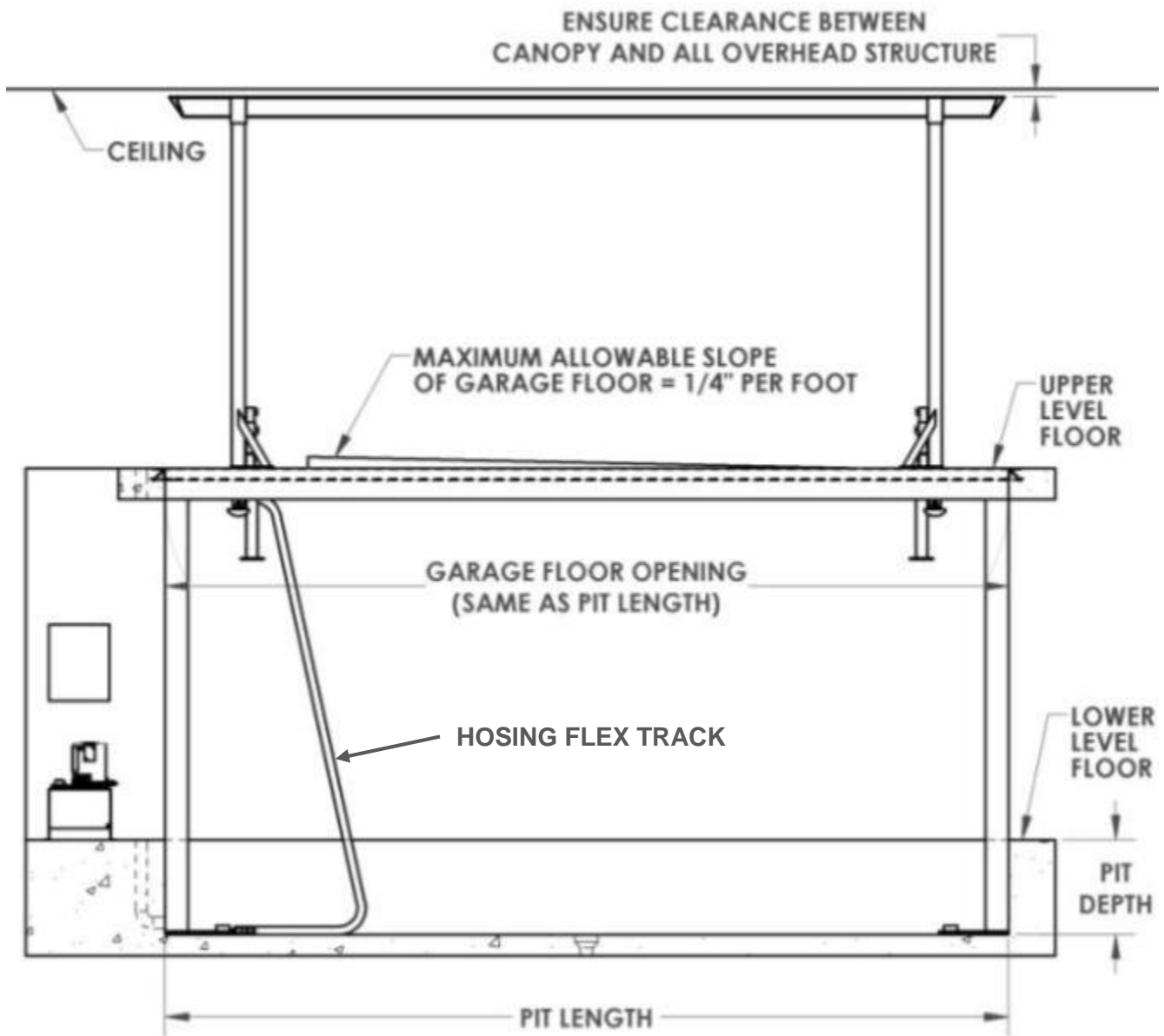

**Side (Elevation) View – Subterranean Pit (Lower Level)**

**NOTES:**

- a) The pipe chase should be installed on the same end of the lift as the power unit and oriented in such a way as to accommodate hosing routed to the power unit.
- b) Install the flexible hose track on the same end of the lift as the pipe chase.

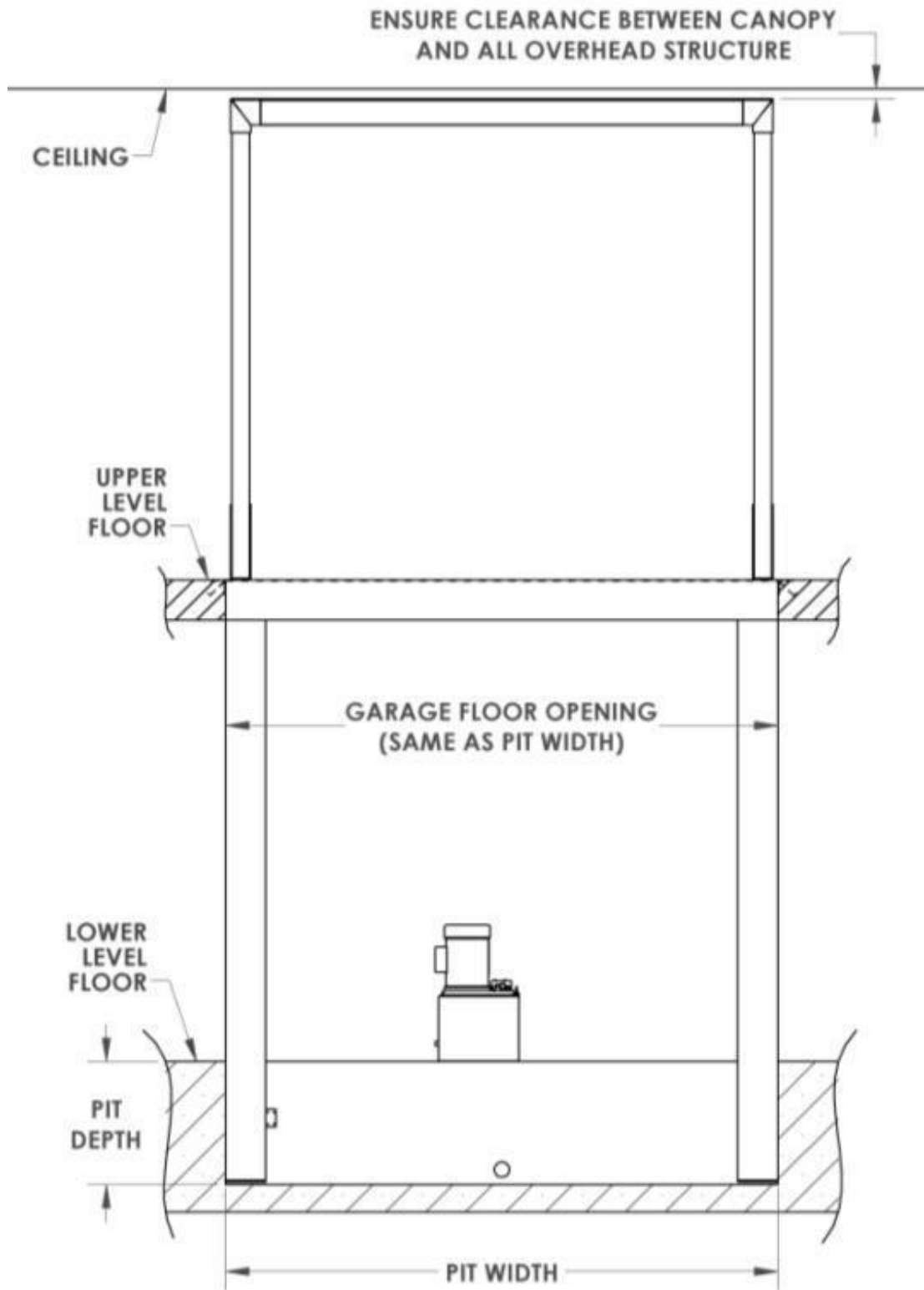

**End (Elevation) View – Subterranean Pit (Lower Level)**



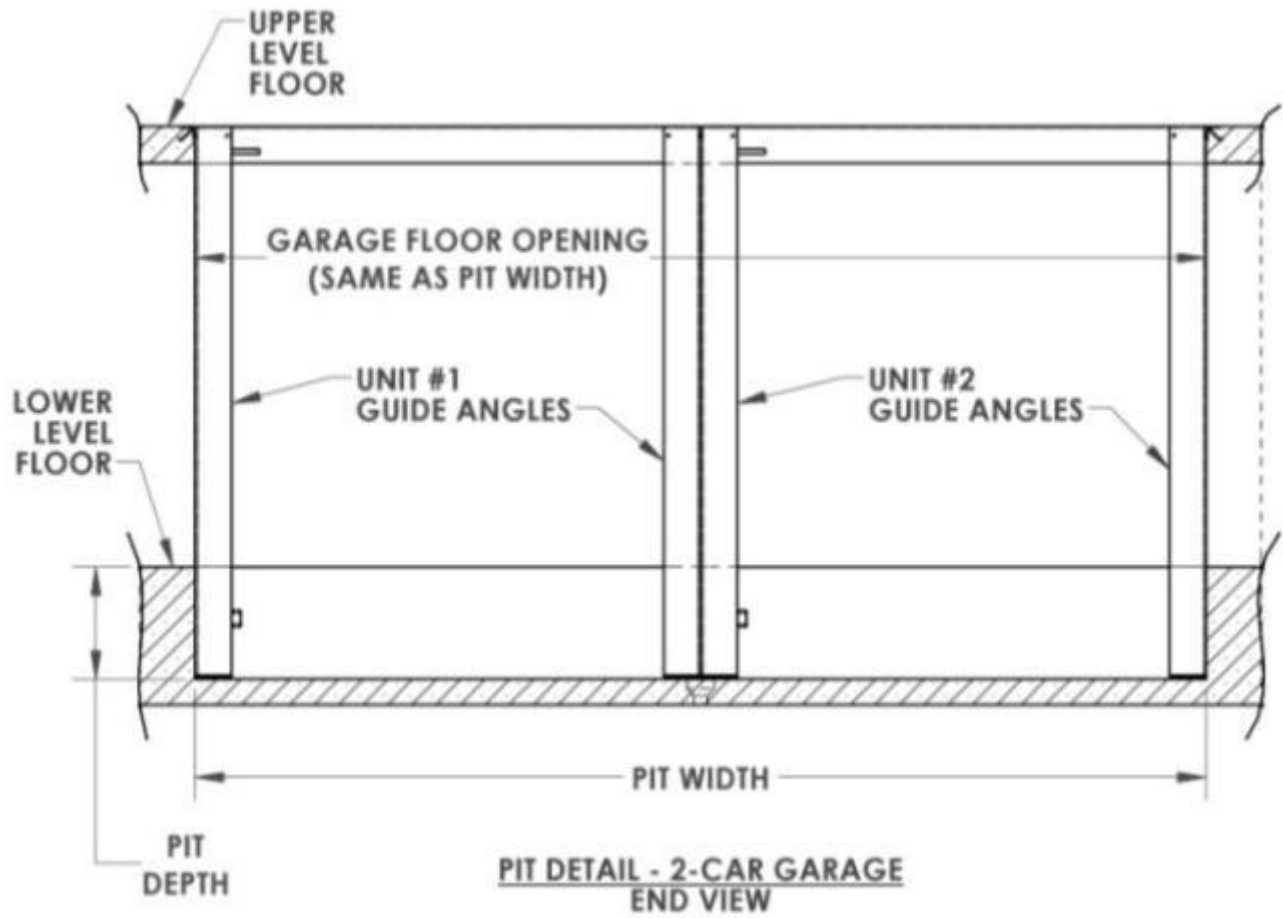

**End (Elevation) View – Subterranean Pit (Lower Level)  
Two (2) Vehicle Garage**

**9.3 Lift Operating Zone.** Care must be taken to evaluate all architectural features which could impact the installation and performance of the subterranean lift:

9.3.1 Verify the construction and integrity of building columns, joists, walls, or mezzanines that will be used to help support the four (4) guide angles.

9.3.2 Be sure to take into consideration any other obstructions (pipes, ductwork, ceiling joists/beams, etc.) that may be located around the lift.

**9.4 Vertical Guide Angles.** Because the 4-post subterranean lift is a platform lift (i.e. not a scissors lift), it achieves its lateral stability from the vertical guide angles that are attached to the building structure at each of the four corners of the lift. In order for the lift to perform as designed, it is critical that these guide angles be installed exactly to manufacturer's specifications, and adhere to the following basic requirements:

9.4.1 When anchoring the corner guide angles to walls, you must be sure that the walls can support the reaction loads imparted on them (see image that follows).

9.4.2 Corner guide angles must be straight and plumb within 1/8" for the lift to operate properly.

9.4.3 Do not modify the guide angles – or any other component of the lift – without expressed written consent from the Manufacturer.

Note: In some areas, seismic calculations may also be required prior to the installation of a subterranean parking lift. Check your local and state requirements for criteria regarding the extent of these calculations and the qualifications required by the engineer who performs them.

**9.5 Utility Room/Area.** It is recommended that an area be dedicated outside the normal living space of the home for the placement of the primary power components of the lift – for security, safety, and maintenance accessibility.

9.5.1 It is customary for the power unit to be placed at the lower level (single phase motors are noisy), and adjacent to the lift (within 25 feet).

9.5.2 It is customary for the motor control panel to be installed adjacent to the power unit.

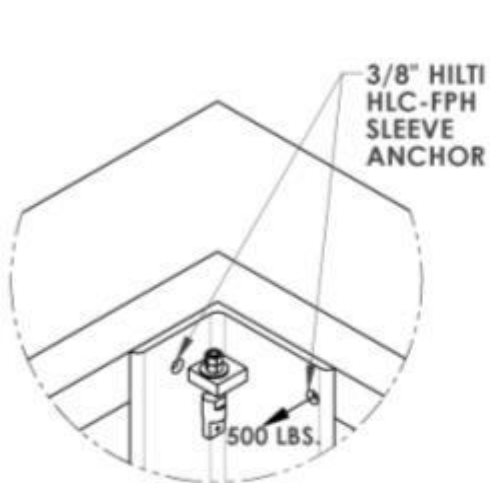
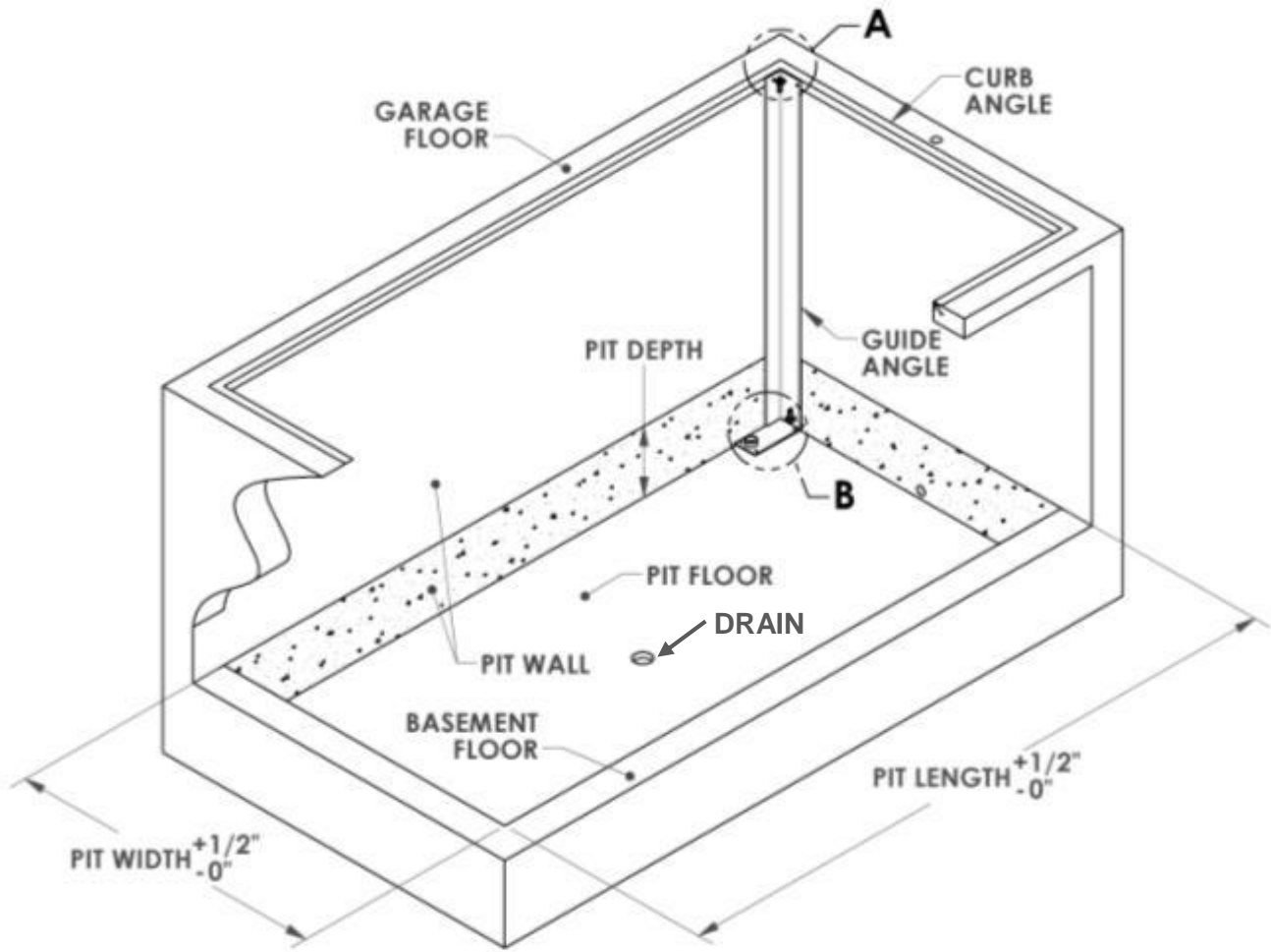

**DETAIL A**  
**TYP (4) CORNERS**

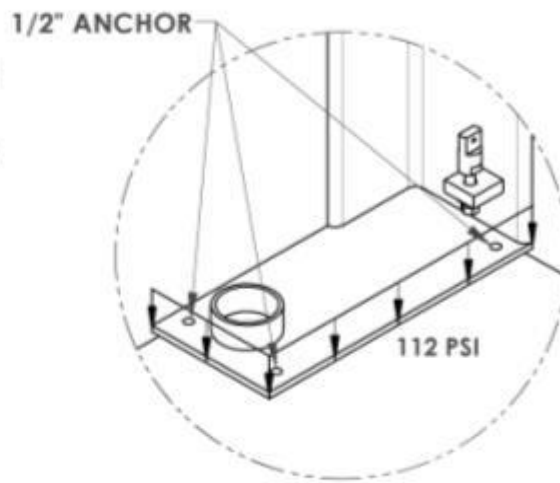

**DETAIL B**  
**TYP (4) CORNERS**

**Guide Angle Connection Details & Reaction Loads**

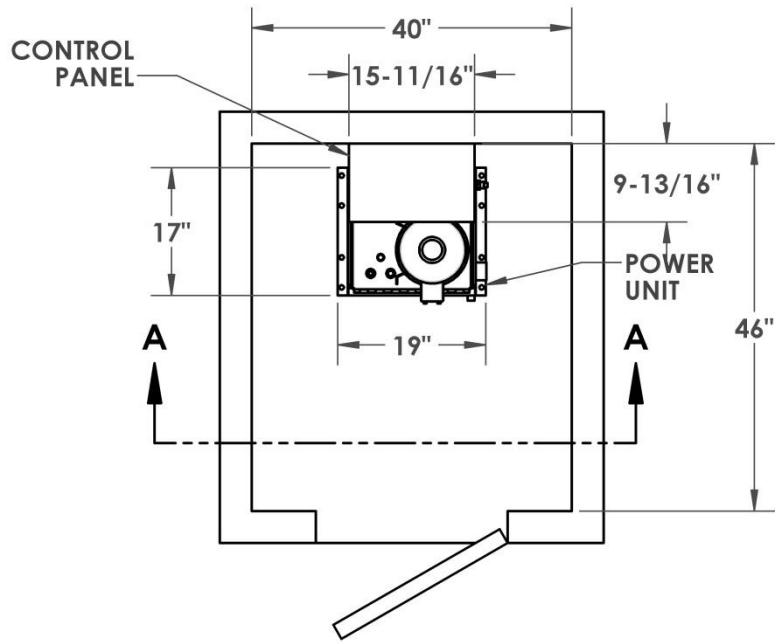

**PLAN VIEW - UTILITY ROOM LAYOUT**  
**ALL DIMENSION ARE APPROXIMATE**

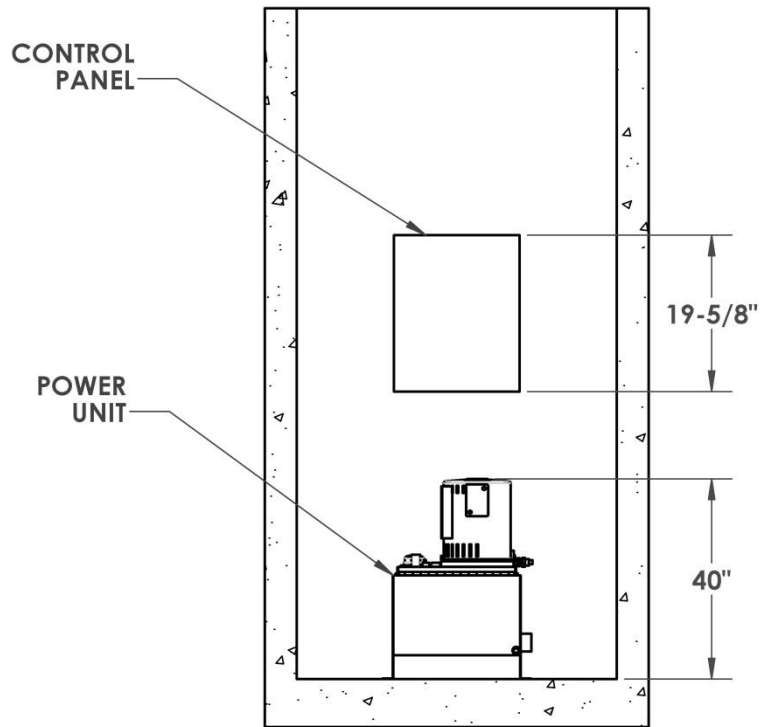

**ELEVATION VIEW - UTILITY ROOM LAYOUT**  
**ALL DIMENSIONS ARE APPROXIMATE**

**SECTION A-A**

**Motor Control Panel & Hydraulic Power Unit**

**9.6 Ship-Loose Electrical Components.** Because the architectural features are unique for each installation, it is necessary to ship many of the electrical devices loose to be field located and wired to the electrical control panel. Listed here are the basic installation specifications for each of the standard electrical components (and some optional ones) to aid in the planning for these devices. Contact Autoquip if more exhaustive technical data is required for any of these components.

**9.6.1 Security Key Switch Station.** This station is the primary security device in the control circuit and requires a physical key to turn the control system “On”. This station is wired in the control voltage circuit to prevent unauthorized operation of the lift.



|   |
|---|
| <b>DIMENSIONS:</b> 3-1/2" x 3-1/2"                                    |
| <b>LOCATION:</b> Secure location, preferably near lift operating zone |
| <b>MOUNTING:</b> Wall Mounted – custom box                            |
| <b>VOLTAGE:</b> 24VDC   |
| <b>MATERIALS:</b> Screwdriver   |

**9.6.2 Digital Keypad Security Station.** This station serves as the secondary security & authorization device and requires a code to be entered to turn the control system “On”. This station is wired in the control voltage circuit to prevent unauthorized operation of the lift. Authorized code times out after 5 minutes and must be re-entered.



|   |
|---|
| <b>DIMENSIONS:</b> 3" x 5"  |
| <b>LOCATION:</b> Secure location, preferably near lift operating zone |
| <b>MOUNTING:</b> Wall Mounted – 1 gang box                            |
| <b>VOLTAGE:</b> 24VDC   |
| <b>MATERIALS:</b> Screwdriver   |

**9.6.3 Operator Pushbutton Station.** This station provides the primary means of raising and lowering the lift and should be located adjacent to the lift operating zone in the vicinity of the security keypad station. The buttons must be pressed and held by the operator during all lift movement – so as to stop the lift by removing finger from button.

|             |   |
|-------------|---|
| DIMENSIONS: | 2" x 4"   |
| LOCATION:   | Adjacent to lift operating zone, in line of sight with lift |
| MOUNTING:   | Wall Mounted – 1 gang box                                   |
| VOLTAGE:    | 24VDC   |
| MATERIALS:  | Screwdriver   |



**9.6.4 Remote Emergency Stop Station.** The Emergency Stop “panic” button which, when pushed, removes electrical power from the control circuit and immediately stops lift movement. E-Stop stations can be located at upper and/or lower level locations, and must be manually reset to continue operation.



|             |  |
|-------------|--|
| DIMENSIONS: | 4" x 4"  |
| LOCATION:   | Adjacent to lift operating zone, out of line of sight of operator (typ. lower level) |
| MOUNTING:   | Wall Mounted – custom box  |
| VOLTAGE:    | 24VDC  |
| MATERIAL S: | Drill, sheetrock screw anchors   |

**9.6.5 Audible “Lift in Motion” Alarm.** An audible signaling device which will activate any time the “UP” or “DOWN” push button is pressed to notify anyone in the area that the lift is being operated. It will continue to signal alarm if the platform is left in any position other than the fully raised or fully lowered positions for more than five seconds. Volume is adjustable.

|             |  |
|-------------|--|
| DIMENSIONS: | 1-1/2" dia   |
| LOCATION:   | Adjacent to lift operating zone, out of line of sight of operator (typ. lower level) |
| MOUNTING:   | Wall Mounted – 1 gang box  |
| VOLTAGE:    | 24VDC  |
| MATERIALS:  | 1 gang blank cover w/1-1/8" hole, “Q” size spade terminals                           |



**9.6.6 Wireless Remote Security Cameras.** Two (2) wireless, digital cameras are mounted at the lower level to give the operator a complete view of the lift operating zone which is outside his/her line of sight. One (1) monitor is located at the operator station to be able to watch all zones during lift operation.



|             |  |
|-------------|--|
| DIMENSIONS: | 8" x 8-1/4" (monitor)  |
| LOCATION:   | Cameras - Lift operating zone (typ. lower level)<br>Monitor – adjacent to operator P/B station |
| MOUNTING:   | Cameras – Wall Mounted<br>Monitor – Tabletop, wall, or under-cabinet                           |
| POWER:      | Cameras – 115VAC plug/350mA (wall outlet)<br>Monitor – 115VAC plug/850mA (wall outlet)         |
| MATERIALS:  | Drill, sheetrock screw anchors (cameras)   |

**9.6.7 Motion Detectors.** Sensors are mounted above and just outside each unprotected edge of the lift platform to detect motion in the lift operating zone outside the line of sight of the operator. If any motion is detected, an electrical contact opens in the control circuit and the operator will not be able to operate the lift until the timer resets (adjustable).



|             |  |
|-------------|--|
| DIMENSIONS: | 3-1/2" dia   |
| LOCATION:   | Lift operating zone, out of line of sight of operator (typ. lower level) |
| MOUNTING:   | Ceiling Mount (kit provided)   |
| VOLTAGE:    | 24VDC  |
| MATERIALS:  | Jigsaw, pencil, screwdriver  |

**9.6.8 Central Command Center (optional).** A single stainless steel enclosure that houses all the standard safety components required at the operating level of the lift operating zone: security key switch, digital keypad, security monitor, and UP/DOWN pushbuttons (can also be customized to house other optional components). Looks great – and simplifies installation.

|             |  |
|-------------|--|
| DIMENSIONS: | 12" x 18" x 4" elect. box (14" x 20" flanges)  |
| LOCATION:   | Adjacent to lift operating zone, within line of sight of operator (typ. upper level)             |
| MOUNTING:   | Wall Mounted – between studs, Nema 1 box with holes for screwing to vertical or horizontal studs |
| POWER:      | 115VAC /400mA monitor & wireless receiver  |
| VOLTAGE:    | 24VDC – other components   |
| MATERIALS:  | Jigsaw/sawzall, misc 2x4 stud material, screws   |



9.6.9 **Vehicle-Present Sensor – Magnetic (optional).** This state of the art sensor is mounted underneath the canopy and senses when a vehicle is on the canopy. If a vehicle is sensed, the sensor opens a contact in the control circuit and the operator will not be able to activate the “UP” button. Requires calibration.



DIMENSIONS: 3/4" x 3"  
 LOCATION: Beneath canopy deck  
 MOUNTING: Locate below engine block; run wiring inside flex track to control panel  
 VOLTAGE: 24VDC  
 MATERIALS: double-sided tape, or epoxy, or tek-screws

9.6.10 **Lift Interference Detection – Photo Eye (optional).** Each interference detection kit includes a photo-eye sensor and separate reflector. Sensors are mounted to “shoot” along an unprotected edge of the lift platform to detect interference in the lift operating zone outside operator’s line sight. If any interference is detected, an electrical contact opens in the control circuit and the operator will not be able to operate the lift until the obstruction is removed.

DIMENSIONS: Sensor – 1-3/4" x 3"; Reflector – 3" dia  
 LOCATION: Wall-mounted  
 MOUNTING: Sensor has 1-1/4" dia bulkhead fitting (wall mounting bracket not included); Reflector has 3/16" dia. hole in center for bolting/screwing  
 VOLTAGE: 24VDC  
 MATERIALS: angle/bracket mat'l, drill, blank cover w/hole



9.6.11 **Ultrasonic Vehicle Position Indicator (optional).** This simple, electronic device mounts to a wall in front of the lift and can be adjusted to ensure that a vehicle being parked on the lower deck for storage is located within the front edge of the deck so as to prevent damage to the vehicle or the lift as the vehicle is lowered from the upper level to the lower level. Requires calibration.



DIMENSIONS: 3" x 5" approx. – Sensor & Display units  
 LOCATION: Garage wall (upper level) in front of lift  
 MOUNTING: Sensor: (2) screws (provided)  
 Display: (2) screws (provided)  
 POWER: 115VAC plug /20mA (separate from lift circuit) or (4) AA batteries  
 MATERIALS: Drill, sheetrock screw anchors



**9.6.12 Swing Door Status Switches and Interlocks (optional).** Door status switches prevent operation of the vehicle lift when the doors/gates are left open on any level. Interlocks prevent the doors/gates from being opened whenever the lift is in motion (interlocks fail to the “open” position in the event of a power failure).

**DIMENSIONS:** 1-1/2” x 8” approx.  
**LOCATION:** Door jamb & latching side of swing door  
**MOUNTING:** Face plate: screws into door jamb  
 Strike: screws into door  
**POWER:** 24VDC – power from control panel to bolt and status switch  
**MATERIALS:** Drill, chisel, hammer

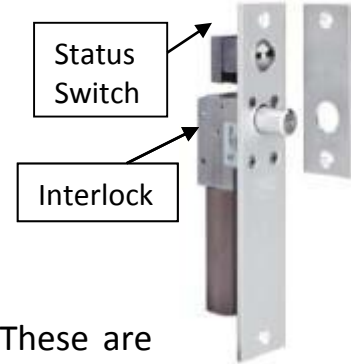

**9.6.13 Overhead Door Status Switches (optional).** These are proximity (non-contact) switches which sense whether an overhead door is in its fully closed position or not, and prevents operation of the vehicle lift if not fully closed (either/both levels).



**DIMENSIONS:** 3-1/8” x 2-1/8”  
**LOCATION:** Bottom of door and floor  
**MOUNTING:** Switch: screws into door jamb  
 Striker: screws into door  
**POWER:** 24VDC  
**MATERIALS:** Drill, screws, screw anchors

**9.6.14 Biometric (fingerprint) Security Scanner (optional).** This high technology security station can be purchased in lieu of the keypad security station to provide secondary security & authorization protection by requiring the scanning of fingerprints (multiple authorizations available) to turn the control system “On” - and prevent unauthorized operation of the lift. Authorized code times out after 5 minutes and must be re-entered.

**DIMENSIONS:** 3” x 6”  
**LOCATION:** Secure location, preferably near lift operating zone  
**MOUNTING:** Wall Mounted – 1 gang box  
**VOLTAGE:** 24VDC  
**MATERIALS:** 1 gang blank cover w/ 7/8” dia hole



9.6.15 **Electrical Junction Box – Pre-Mounted to Lift (optional).** For customers who would like to add their own electrical features to the lift (lights, video screens, etc.) an electrical junction box can be pre-mounted to the underside of the top canopy deck, and provisions made for wiring to be able to be routed inside one of the canopy support posts to the flexible utility track beneath the lift.

## 9.7 **Electrical Installation Notes.**

9.7.1 **Code Compliance.** All electrical work must meet the requirements of all state and local codes, make sure that only qualified electricians perform all wiring.

9.7.2 **Control Panel.** The control panel is shipped loose with all internal components pre-wired to terminal strip(s) and all control logic managed by programmable relays.

9.7.3 **Bi-Level Operation.** If the lift is to be operated from both levels, a duplicate set of electrical control and safety devices must be purchased – to ensure safeguarding of the landing that is out of the line of sight of the operator.

9.7.4 **Bypassing Devices.** Never bypass any safety sensor or device.

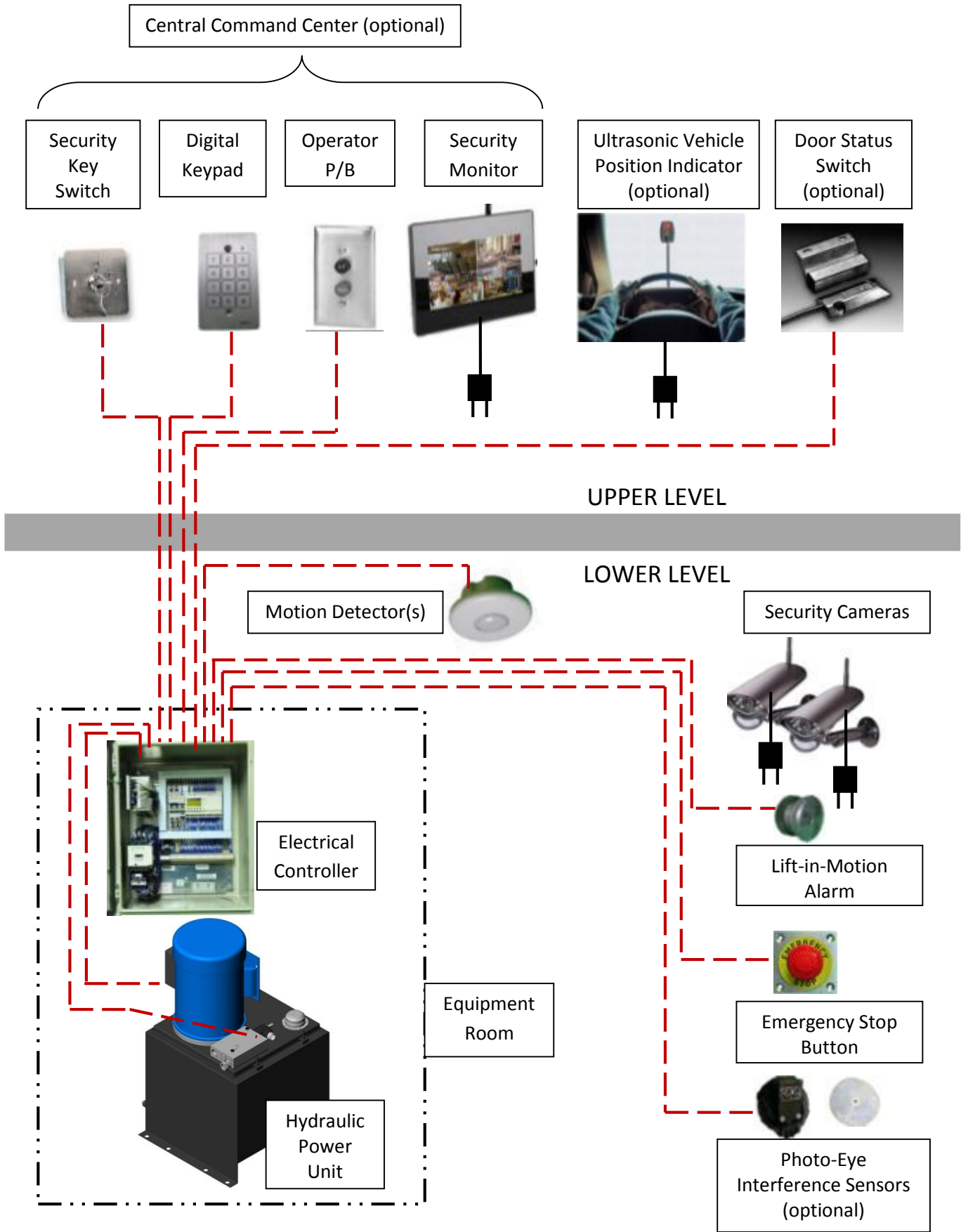

**Electrical Components – General Arrangement**

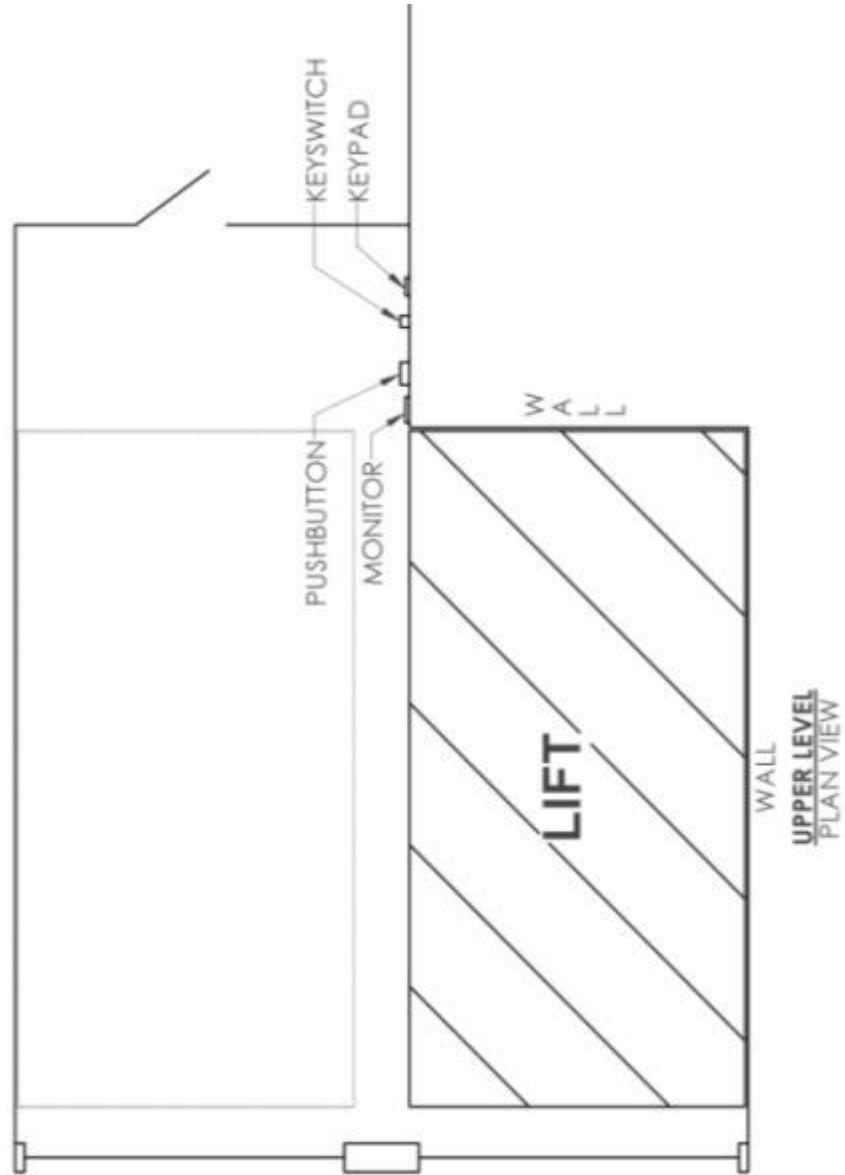

**SAFETY DEVICE & SENSOR LAYOUT –  
UPPER LEVEL (Plan View)**

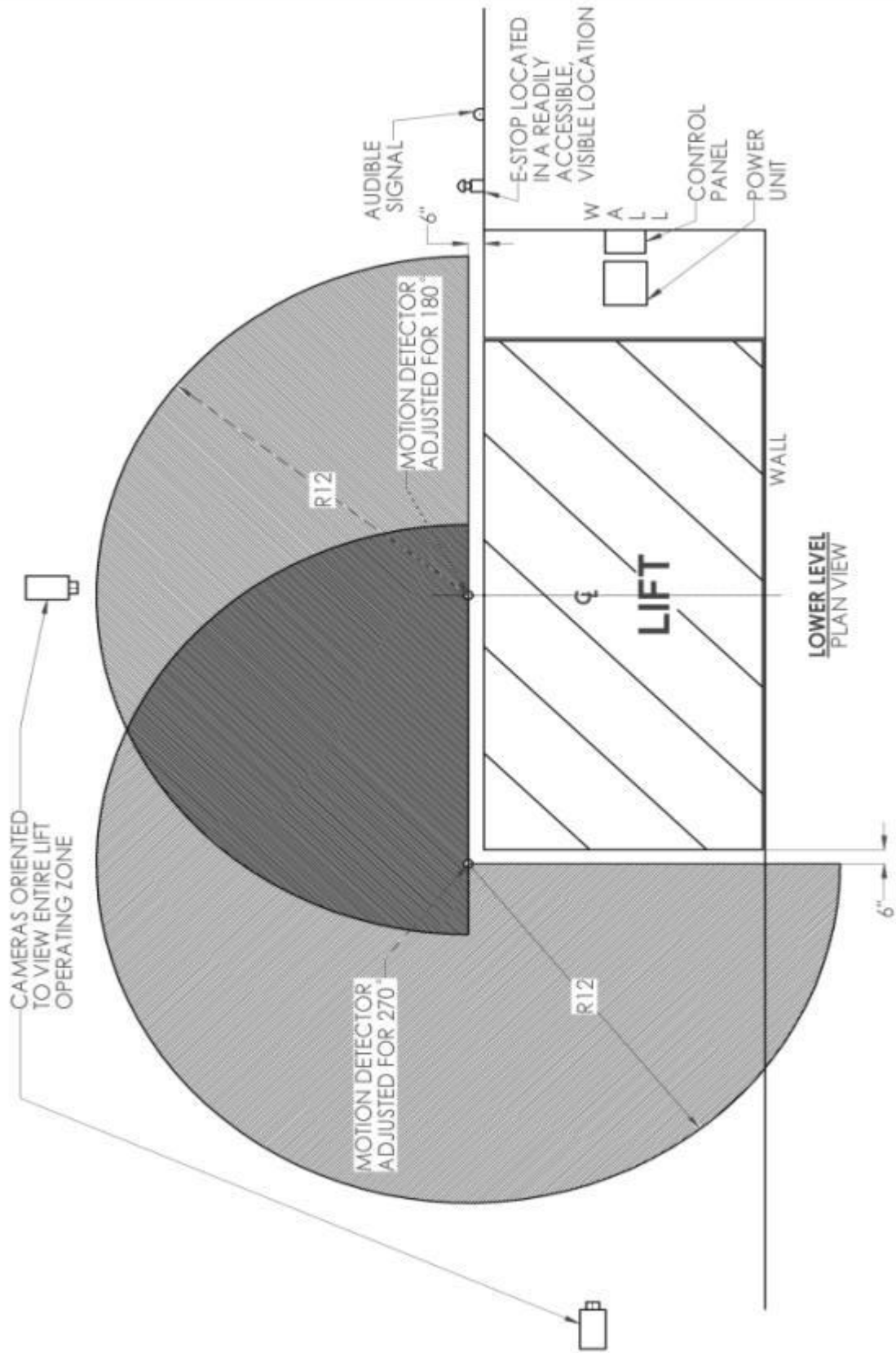

**SAFETY DEVICE & SENSOR LAYOUT –  
LOWER LEVEL (Plan View)**

## 10. SAFETY LABELS & FEATURES

### 10.1 Safety Labels

#### 10.1.1 CAUTION – Familiarize Yourself with Operators Manual Before Operating Lift (Label #1)



#### 10.1.2 DANGER – General Purpose Safety Label (Label #2)



#### 10.1.3 WARNING – Do Not Tamper or Interfere with This Device (Label #3)



Field-locate & apply one “WARNING – Do Not Tamper” label adjacent to (within 6”-12”) each sensing device (limit switches, door status switches, door interlocks, etc.) in a location that is visible to the operator.

#### 10.1.4 Maintenance Device Label (Label #4)



#### 10.1.5 Maintenance Device Placement (Socket) Label (Label #5)



## 10.1.6 Warning – General Purpose Safety Label (Label #6)

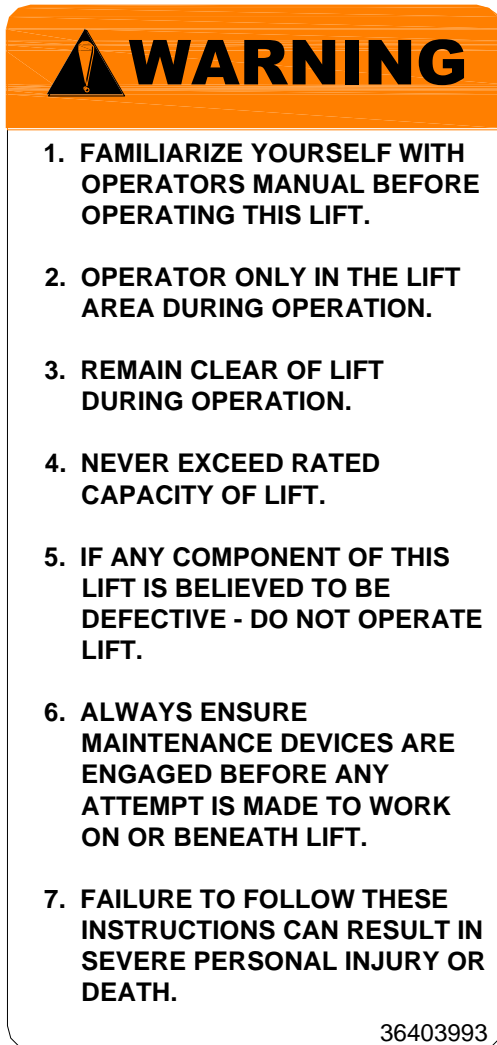

**WARNING**

1. FAMILIARIZE YOURSELF WITH OPERATORS MANUAL BEFORE OPERATING THIS LIFT.
2. OPERATOR ONLY IN THE LIFT AREA DURING OPERATION.
3. REMAIN CLEAR OF LIFT DURING OPERATION.
4. NEVER EXCEED RATED CAPACITY OF LIFT.
5. IF ANY COMPONENT OF THIS LIFT IS BELIEVED TO BE DEFECTIVE - DO NOT OPERATE LIFT.
6. ALWAYS ENSURE MAINTENANCE DEVICES ARE ENGAGED BEFORE ANY ATTEMPT IS MADE TO WORK ON OR BENEATH LIFT.
7. FAILURE TO FOLLOW THESE INSTRUCTIONS CAN RESULT IN SEVERE PERSONAL INJURY OR DEATH.

36403993

Field-locate & apply this decal adjacent to the lift at each level, ideally in the vicinity of the operator pushbutton station.

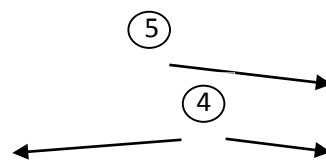
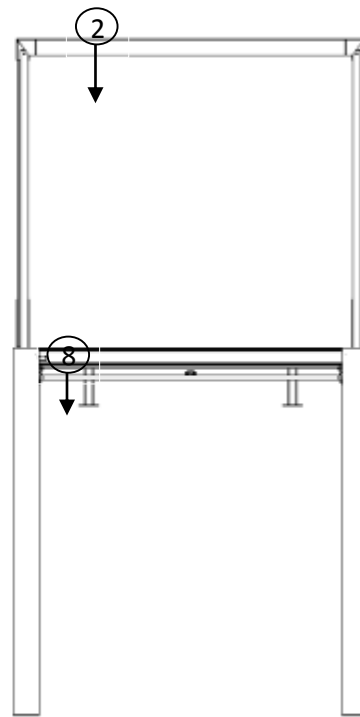
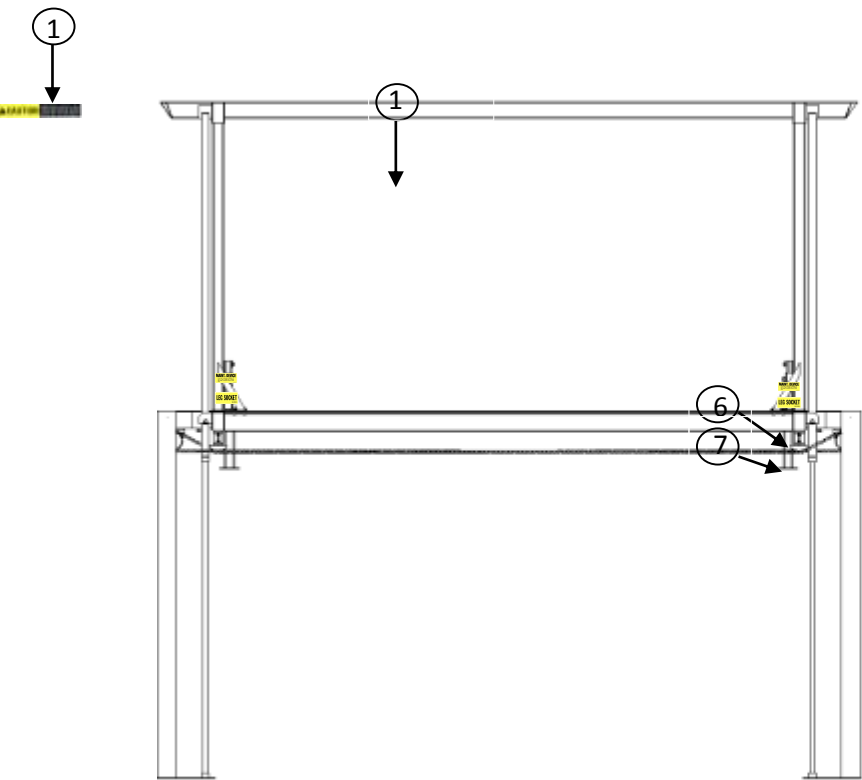



## Label Placement Diagram

### 10.2 Lift Safety Features (non-electrical)

**10.2.1 18" Refuge Space beneath Lift.** A mechanical feature unique to the 4-Post style lifts is a completely clear 18" crawl space beneath the entire lower deck for personnel safety during operation and maintenance.

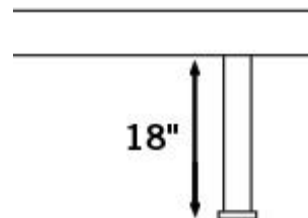

**10.2.2 Beveled Toes Guard Protection.** A mechanical feature added to the perimeter of the lift platform intended to push away, rather than pinch, a shoe which is overhanging a landing by up to 4 inches.

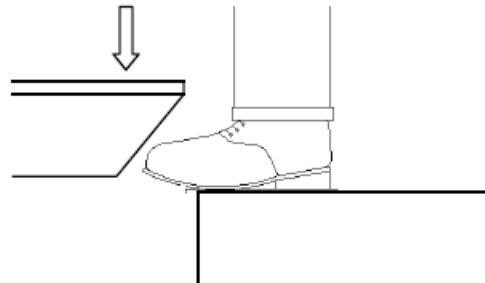

**10.2.3 Hydraulic Velocity Fuses.** Each lifting cylinder is equipped with a hydraulic "fuse" which senses the flow of oil. In the event of a sudden rupture in the hydraulic circuit,

the fuse senses the abnormally high velocity of oil and automatically closes off the flow of oil coming from the cylinder, thereby arresting/stopping the fall of the lift.

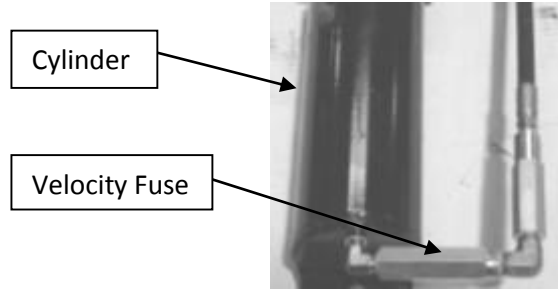

**10.3 Automatic Re-Pressurization Circuit.** An automatic self-leveling feature where, if the lower carriage is left in the raised position for an extended period of time, switches sense whether the carriage is slowly drifting away from the upper landing (normal in all hydraulic circuits). In order to prevent the possibility that the driver or other passers-by do not notice that that carriage has moved away from the landing – the lift re-levels itself after it drifts down approximately 1-2”.

## 11. SHIPPING & HANDLING

### 11.1 Typical Component Weights:

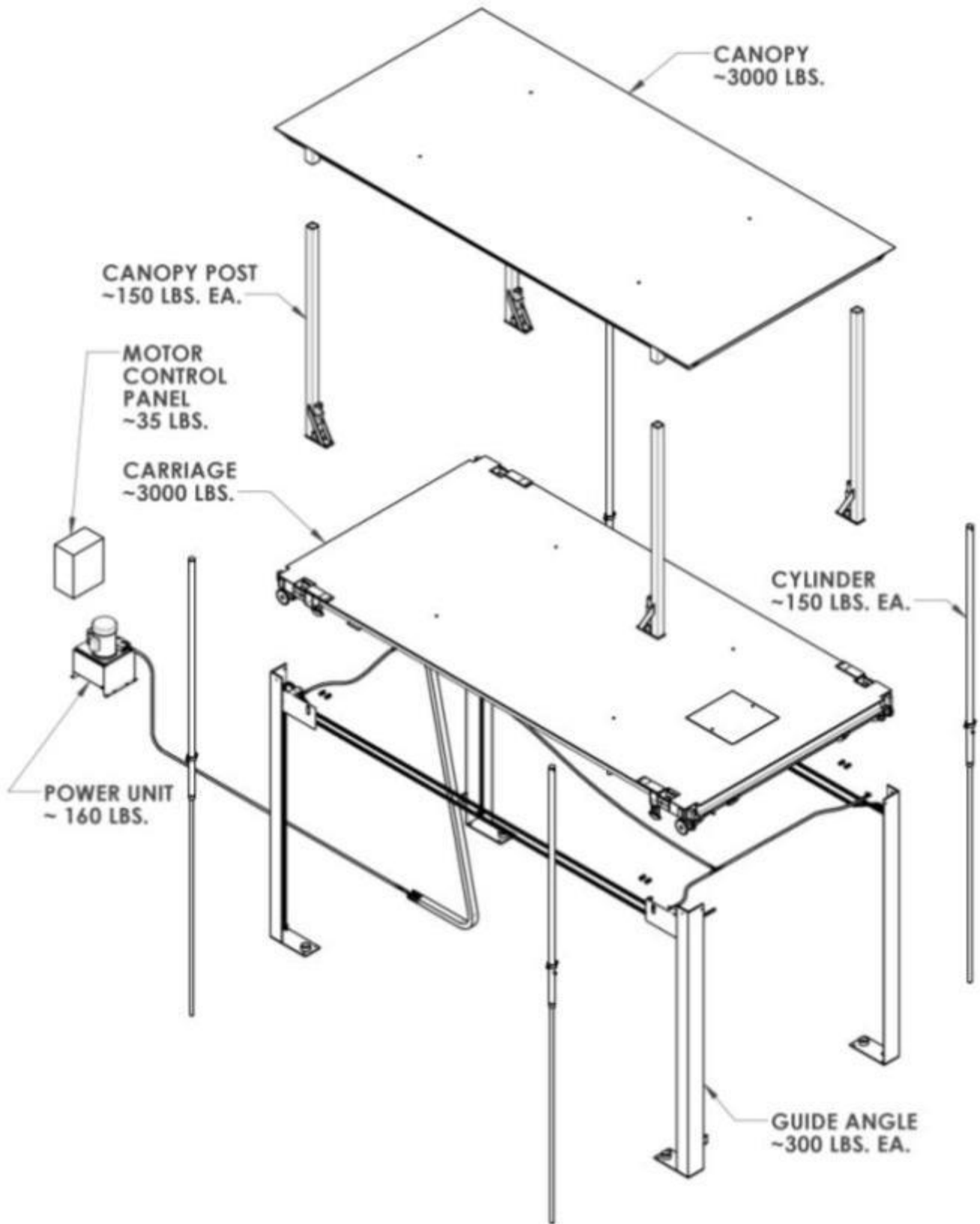

## 12. START-UP TESTING

### 12.1 Typical Start-up Procedure:

- a) Close all doors/gates leading into the lift operating zone.
- b) Run the empty carriage to the upper landing.
- c) Check that doors at all levels will not open while the lift is running.
- d) Check to ensure the lift will not operate if any door is open.
- e) Place a load on the carriage and lower the carriage to the lower landing, then back up again. The carriage should stop at the upper elevation even with the landing – whether loaded or unloaded.
- f) Allow a loaded carriage to remain at the upper level for 4 hours. Platform should not drift or leak oil.
- g) Check to ensure the lift operates at the rated speed.
- h) The parking lift should function smoothly and relatively quietly. If the lift does not function as stated in the Owner’s Manual, or does not pass these tests, consult the manufacturer before putting the lift into service.
- i) Check that each of the safety devices delivered with the lift, and described herein, will stop the moving carriage if activated.

## 13. MAINTENANCE SCHEDULE

The following is a basic inspection schedule designed to help ensure that your parking lift is operating correctly, and to identify potential problem areas that should be inspected further by a qualified service representative. Lifts installed in more severe environments - outdoors (rain, ice), near the ocean (salt), etc. – may require more frequent inspection of structural & mechanical components:

### 13.1 Each Month

- a) Check hydraulic fluid level. Note: With lift fully lowered, fluid level should be approximately 1-1/2” from top of tank. DO NOT OVERFILL
- b) Check for hydraulic fluid leaks
- c) Check all hydraulic hoses and electrical cords for cracks, abrasions, twisting, etc. Small leaks at connections can be remedied by tightening connections or replacing the faulty component.
- d) Check all bearings for noise and wear.
- e) Check overall condition of unit (i.e. bends, breaks, loose or missing screws, metal shavings on floor, etc.).

- f) Check to be sure that all equalization chains beneath the lower platform are properly engaged with their respective drive sprockets. Call a qualified service technician immediately if chains are broken or have come loose from their designated chain path.

### **13.2 Every Six Months**

- a) Check quality of hydraulic fluid, replace if discolored (oxidized), cloudy, or otherwise contaminated. DO NOT OVERFILL. Always use clean fluid. Never return fluid from drip pans, pit, etc. back to reservoir. Dispose of and handle used fluid as a hazardous material.
- b) Check lift cylinder rods for scoring and leaking. Wipe any foreign material from cylinders.
- c) Check all structural and mechanical components for cracked, or broken welds and any distortion caused by collision, overloading, or other misuse.
- d) Check the plastic wear pads mounted to the outside of each corner of the lower platform. Call a qualified service technician if there is less than 1/4" of pad material remaining.
- e) Grease the shaft bearings located beneath the lower vehicle platform at the front and rear of the lift with light grease.

NOTE: When all above checks have been completed start unit and operate through all functions. Inspect all components for signs of noise, vibration, erratic movement, and any other abnormal behavior.

### **13.3 Once Per Year**

- a) Change hydraulic fluid and clean reservoir. Never return fluid from drip pans, pit, etc. back to reservoir. Dispose of and handle used fluid as a hazardous material.
- b) Replace all filters.
- c) Raise lift platform approximately 24 inches. Note exact distance from floor level to top of platform (round off to nearest 1/16 inch). Leave idle for 15 minutes. Check distance again. If any movement is measured, call a qualified service technician to make repairs as required.
- d) Tighten all equalization chains located beneath the lower platform per instructions in the Installation and Maintenance manual.

## LIMITED WARRANTY STATEMENT

The user is solely responsible for using this Equipment in a safe manner and observing all of the safety guidelines provided in the Owner's Manual and on the warning labels provided with the lift. If you are unable to locate either the manual or the warning labels, please contact Autoquip or access [www.vasari-lifts.com](http://www.vasari-lifts.com) for replacement downloads or information.

Autoquip Corp expressly warrants that this product will be free from defects in material and workmanship under normal, intended use for a period of Two (2) Years for all electrical, mechanical, and hydraulic components, parts or devices, and warrants the structure of the lift against breakage or failure for a period of Ten (10) Years. This warranty includes parts and labor for the first year of the warranty period, parts only thereafter. The warranty period begins from the date of shipment. When making a claim, immediately send the dealer who sold you the unit a notice of your claim. All claims must be received within the warranty time period. The maximum liability of Autoquip under this Limited Warranty is limited to the purchase price of the Equipment.

This warranty shall not apply to any VASARI lift or parts of VASARI lift that have been damaged or broken in transit/shipping, or due directly or indirectly to misuse, abuse, vehicle impact, negligence, faulty installation, fire, floods, acts of God, accidents, or that have been used in a manner contrary to the manufacturer's limitations or recommendations as stated in the Manual, or that have been repaired, altered or modified in any manner outside of Autoquip Corp's manufacturing facility or which have not been expressly authorized by Autoquip.

Autoquip Corp makes no warranty or representation with respect to the compliance of any Equipment with state or local safety or product standard codes, and any failure to comply with such codes shall not be considered a defect of material or workmanship under this warranty. Autoquip Corp shall not be liable for any direct or consequential damages resulting from such noncompliance.

Autoquip Corp's obligation under this warranty is limited to the replacement or repair of defective components at its factory or another location at Autoquip Corp's discretion at no cost to the owner. This is owner's sole remedy. Replacement parts will be warranted for the remainder of the Equipment Warranty period or ninety (90) days, whichever is longer. Except as stated herein, Autoquip Corp will not be liable for any loss, injury, or damage to persons or property, nor for direct, indirect, or consequential damage of any kind, resulting from failure or defective operation of said Equipment. All parts used to replace defective material must be genuine Autoquip parts in order to be covered by this Limited Warranty.

Some states do not allow the exclusion or limitation of incidental or consequential damages, so those limitations may not apply to you. This warranty gives you specific legal rights and you may also have other rights which vary from state to state.



**CONTACT US FOR A FREE CONSULTATION (303) 623-7433**

Denver Metro 720.881.2692 • Colorado Springs 719.635.7960 • Glenwood Springs 970.384.2212