

MH8210 INSTRUCTION MANUAL

PARTS LIST

QTY	REFERENCE	DESCRIPTION
2	A	Handle Sections
2	B	Frame Connector
2	C	Support Frame
2	D	Zinc Plated Reel Shaft
1	E	Zinc Plated Wheel Axle
2	F	Wheel

HARDWARE KIT

QTY	REFERENCE	DESCRIPTION
2	G	1/4-20 x 1-1/4 Handle Bolt
2	H	1/4-20 Nylon-insert Lock Nut
4	J	5/8 x 1-1/4 Flat Washer
2	K	1-1/2 Cotter Pin
6	L	3 x 65 Hitch Pin Clip

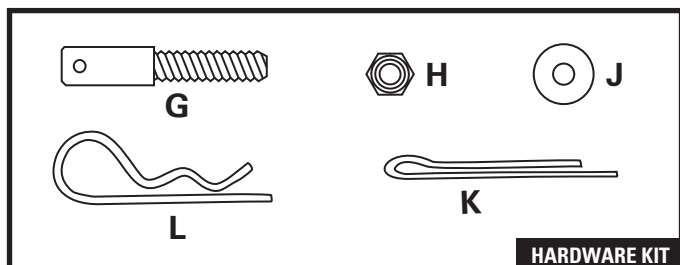

HARDWARE KIT

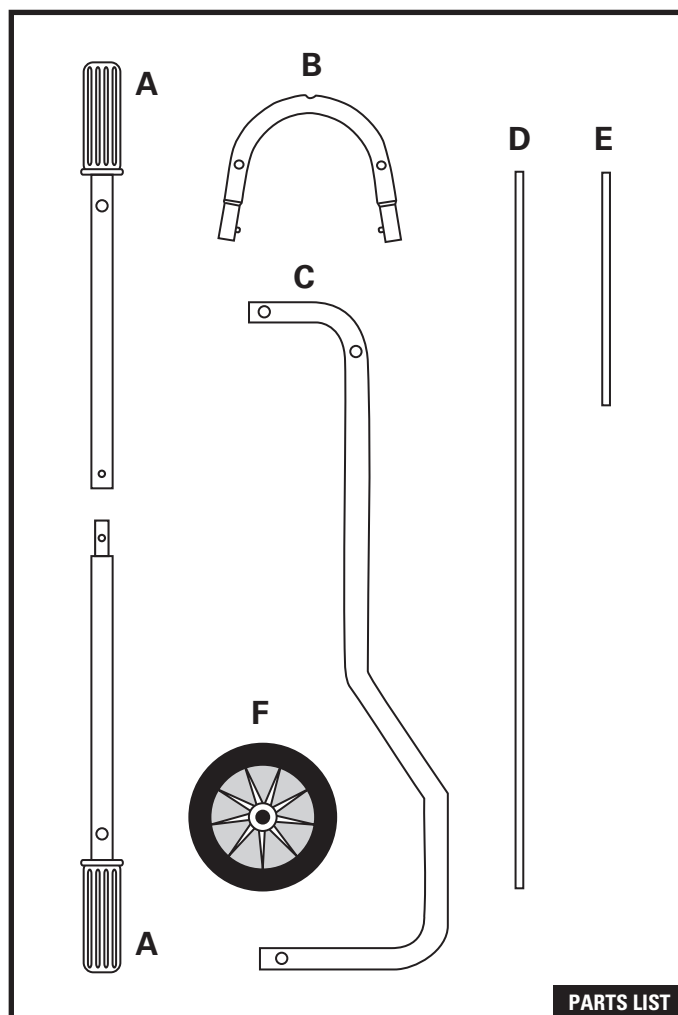

PARTS LIST

SAFETY RULES

This product was designed for certain applications only. Madison strongly recommends that this product not be modified and/or used for any purpose other than that for which it was designed.

CAUTION: Use care when lifting the Wire Handling Cart. Unload spools first. Do not use as a step or ladder.

Tools Required for Assembly

7/16-inch wrench or socket. Channel lock or vise grip pliers.

For Parts, Accessories or Warranty Assistance, Please call: 1-800-631-7775

CAPACITY	# OF SPOOLS	SPOOL DIMENSIONS
	12	7" diameter x 5" wide
	6	7" diameter x 6"-10" wide



WireSMART

WIRE HANDLING CART

ASSEMBLY INSTRUCTIONS

FIGURE 1

Insert Handle Bolt (G) into hole on the top of Frame Connector (B). Secure using 1/4 x 20 Nylon-Insert Locknut (H).

NOTE: When tightening Nylon Locknut (H) make sure hole in Handle Bolt is parallel to Frame Connector (B). Repeat for the second Frame Connector.

FIGURE 2

Insert Frame Connector (B) into the two Support Frames (C). Push down firmly until Ball Pins in Frame Connector (B) snap into holes in the Support Frame (C). Repeat for the second Frame Connector.

FIGURE 3

Insert one Handle Section (A) into the other. Push together until the ball pin snaps into place. Line up the large holes in Handle assembly (A) with the Handle Bolts (G) on the top of each Frame Connector (B).

NOTE: Make sure dimple holes in Handle are facing upward. Push down Handle over Handle Bolts and secure with Hitch Pin Clips (L).

FIGURE 4

Slide the Zinc Plated Wheel Axle (E) through the hole in the bottom of Support Frame (C). Using Wheels (F), 5/8" x 1-1/4" Flat Washers (J) and 1-1/2" Cotter Pins (K) secure Wheels and Axle.

NOTE: After inserting Cotter Pin (K) through hole in Wheel Axle (E), bend pin upward to lock in place.

FIGURE 5

Slide the Zinc Plated Reel Shafts (D) through the holes in the side of the Frame Connectors (B). Secure using Hitch Pin Clips (L).

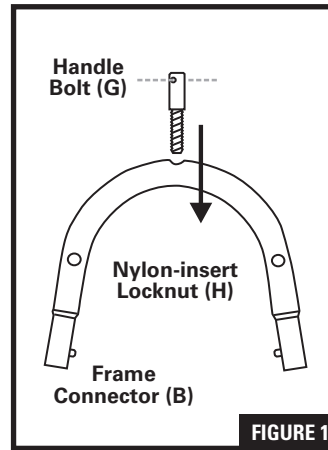

FIGURE 1

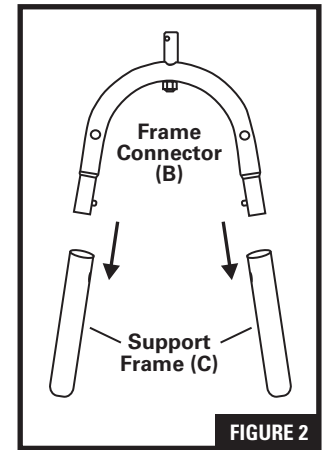

FIGURE 2

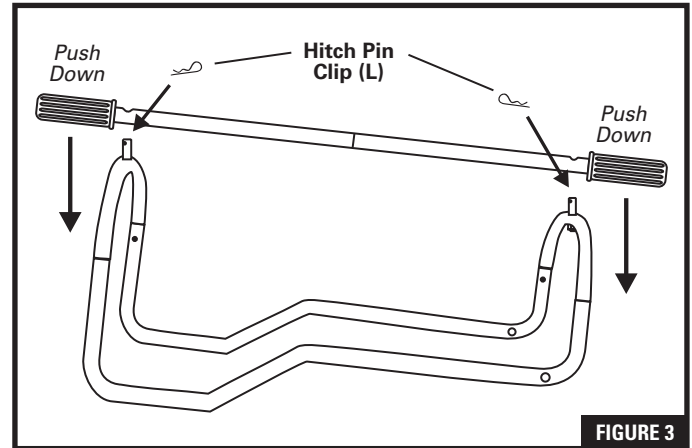

FIGURE 3

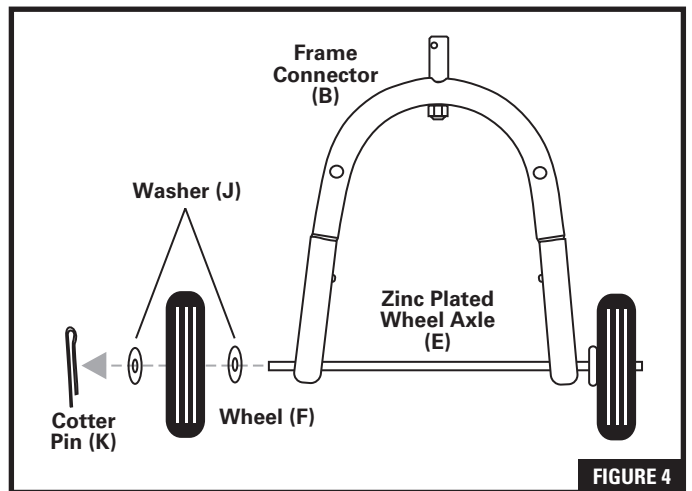
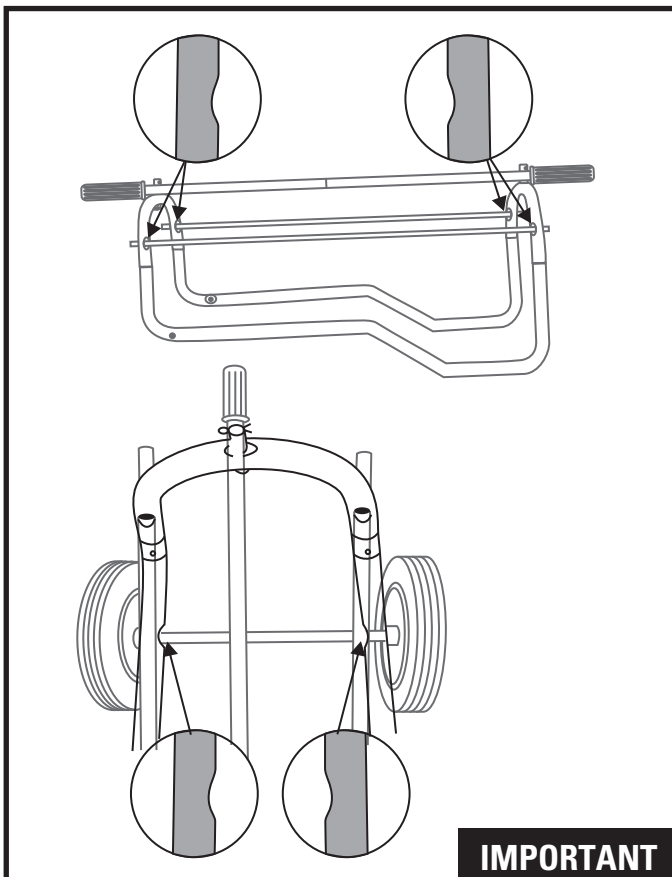

FIGURE 4



IMPORTANT

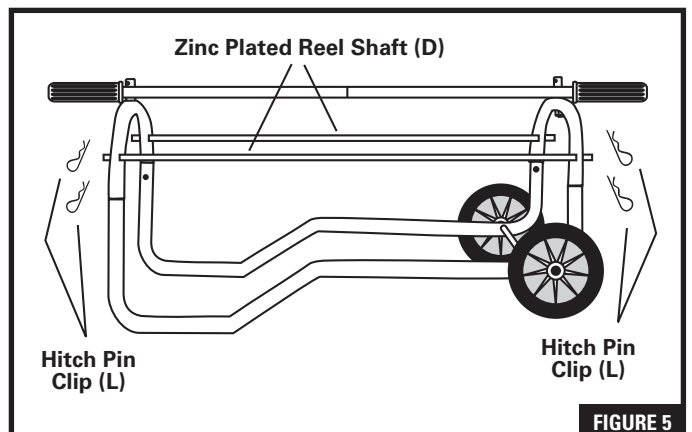

FIGURE 5