



---

# Planning Guide

---

## **Residential and Commercial Dumbwaiters**

**Series 007 - Cable-Waiter (Residential)**

**Series 011 - Paca-Waiter (Residential)**

**Series 311 - Paca-Waiter (Commercial)**

**Series 511 - Paca-Waiter (Commercial)**



# Waupaca Elevator's Mission Statement

Our mission is to deliver and support an enhanced quality of life for people with a need or want for vertical transportation. We are dedicated to our relationships, products, and industry through teamwork and education.

Waupaca Elevator Company, Inc, Elevator is a proud member of The American Society of Mechanical Engineers, The National Association Elevators Contractors, The Canadian Elevator Contractor Association, The Accessibility Equipment Manufacturers Association. These symbols assures you of our commitment to high quality and accessibility to everyone.



## Table of Contents

Introduction & Planning Steps .....	4
Dumbwaiter Reference Chart .....	5-7
Car Gate Reference Chart .....	8
Commercial Hoistway Door Reference Chart .....	9
Residential Mechanical Illustrations.....	10
Commercial Mechanical Illustrations.....	11
Elevation Layout .....	12-14
Electrical Room Layout.....	15
Hoistway Rail Layout.....	16-17
Hoistway Layout .....	18-24
Typical Dumbwaiter Equipment.....	25
Notes.....	26

---

# Introduction

This Planning Guide is to be used as a reference to determine parameters of installation and steps taken to achieve a proper dumbwaiter installation. This guide may be used by the architect, contractor, dealer or home owner. The information in this guide is intended as an overview. Each installation will have job specific specifications that must be followed. Do not attempt to construct a hoistway on this information.

Dumbwaiter installation is to be done by an authorized elevator contractor, and in accordance with installation instructions provided by the manufacturer. Installation must also be in compliance with requirements of the National Electric Code, American Society of Mechanical Engineers safety code, and state and local building codes. Waupaca Elevator's products are designed to meet the requirements of ASME - A17.1 National Elevator Codes for dumbwaiters. Manufacturer assumes no liability for equipment not installed in compliance with these codes.

Waupaca Elevator Company, Inc., reserves the right to modify the design, technical specifications and dimensions of the products shown in this document.

---

# Planning Steps

Locate local dealer and custom design your dumbwaiter together. Please follow the steps below to finish creating your dumbwaiter package:

1. Determine the location and how dumbwaiter will be used. Select car type, gate type, capacity of the dumbwaiter and choose from the available option that are referenced in the Waupaca Elevator Brochure.
2. Layout machine room and location.
3. Plan for all electrical requirements
4. Address national, state and local code requirements.
5. Obtain and follow site specific field drawings. Forward all necessary documents to contractor/builder, architect, and structural engineers. Use job specific drawings while building hoistway, doorways, machine room, and any other construction related to the dumbwaiter.
6. Coordinate with your dealer to install your custom dumbwaiter.

# Dumbwaiter Reference Chart

Residential Units			
Mechanical Features		Cable-Waiter	Paca- Waiter
<b>Weight Capacity</b>	Up To...	100 lbs.	200 lbs.
<b>Travel</b>	Up To...	50'	34'
<b>Stops</b>	Up To...	6 Stops	
<b>Nominal Speed</b>	Feet Per Minute	30 FPM	50 FPM
<b>Overhead</b>	Recommended space above top of car. Additional overhead required for some car gates or overhead machine configuration's	1'-6"	2'-0"
<b>Electrical Requirements</b>	Phase	Single	
	Voltage	110 V	230V
	Amperage	15 A	10 A
<b>Drive System</b>		Winding Drum	
<b>Motor</b>	Horsepower	3/4 HP	1.5 HP
<b>Controller Size</b>	Height x Width x Depth	18" x 18" x 6"	
<b>Sheave</b>	Diameter	4"	6-3/8"
<b>Drum</b>	Diameter	5-1/4"	5-3/4"
<b>Cable Type</b>		1/8" x 7 x 19 GAC	3/16" x 7 x 19 GAC
<b>Rail Type</b>	Steel	1-1/2" x 1-1/2" x 1/8" Angle	2" x 1" x 3/16" C Channel
<b>Machine Placement</b>		Above or Below	

# Dumbwaiter Reference Chart

<b>Commercial Units</b>			
<b>Mechanical Features</b>		<b>Cable Waiter</b>	<b>Paca-Waiter</b>
<b>Weight Capacity</b>	Up To...	300 lbs.	500 lbs.
<b>Travel</b>	Up To...	50'	
<b>Stops</b>	Up To...	6 Stops	
<b>Nominal Speed</b>	Feet Per Minute	60 FPM	
<b>Overhead</b>	Recommended space above top of car. Additional overhead required for some car gates or overhead machine configurations	2'-3"	
<b>Electrical Requirements (Buck Boost Required on Paca-Waiter Units)</b>	Phase	Single	
	Voltage	230 V	
	Amperage	25 A	
<b>Drive System</b>		Winding Drum	
<b>Motor</b>	Horsepower	2 HP	3 HP
<b>Controller Size</b>	Height x Width x Depth	24" x 24" x 8"	
<b>Sheave</b>	Diameter	7-3/4"	
<b>Drum</b>	Diameter	7-3/4"	
<b>Cable Type</b>		1/4" x 7 x 19 GAC	
<b>Rail Type</b>	Steel	2" x 1" x 3/16" C Channel	
<b>Machine Placement</b>		Above or Below	

# Dumbwaiter Reference Chart

<b>Car</b>
<b>Material:</b>
Powder Coated Steel
Stainless Steel #4 Finish
<b>Car Options:</b>
Shelves
Light

<b>Gates (required)</b>
<b>Bi-parting or Slide-up:</b>
Powder Coated Steel
Stainless Steel #4 Finish
<b>Tambour (Roll-up):</b> PVC (CW 100 & PW 200 residential dumbwaiters only)

<b>UL "B" Label Hoistway Door(s) for Residential/Commercial Units</b>		
<b>Door Types:</b>	<b>Material:</b>	<b>Optional:</b>
Bi-Parting	Primed Steel	Frame mounted push buttons, Indicator Light option, Stainless Sill(s), Counter Loading, Floor Loading, Fusible Link, Emergency Release, Door Switch
Slide-Up Doors	Stainless Steel #4 Finish	
Swing Doors	Powdered Coated	

<b>Access Door(s) UL "B" Label Hoistway Door(s)</b>
<b>Materials:</b>
Primed Steel
Stainless Steel. #4 Finish
Powdered Coated

<b>Residential Units</b>		
<b>Custom Wood Doors:</b>	<b>Trims:</b>	<b>Options</b>
Various Different Styles	Stainless Steel #4	Frame mounted push buttons indicator light options
	Wood	
	Trim less	

<b>Interlock(s) (required)</b>
HG-1 Single Contact Interlock HG-2 Dual Contact Interlock (Used on Commercial Doors)
GAL and Cam(s)
EMI III
<b>* Note :</b> Either GAL, HG-1 or HG-2 Interlock(s) Are Required On Commercial Units

<b>Additional Options:</b>
Door Open Buzzer (CW 100 & PW 200)
Gate & Door Alarm (CW 100 & PW 200)
Car Here
In Use
Lantern and Chime
Position Indicator

# Car Gate Reference Chart

The dumbwaiter car gate, is attached to the front of the car and travels with it up and down the hoistway. The gate prevents items from leaving or entering the car.

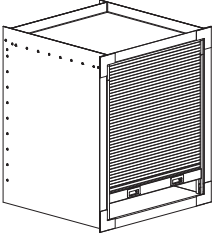
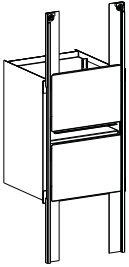
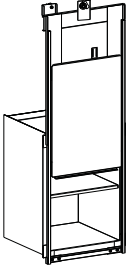
<p><b>Steel Car with PVC or Metallic Rolltop Gate</b></p> 	<p><b>Cable-Waiter</b></p> <p>Available in 100 lb. cars</p> <p>Available Finishes &amp; Material: PVC or Metallic Steel w/ PVC Coating</p>	<p><b>Paca-Waiter</b></p> <p>Available in 200 lb. cars</p> <p>Available Finishes &amp; Material: PVC or Metallic Steel w/ PVC Coating</p>
<p><b>Steel Car with Bi-Parting Gate</b></p> 	<p><b>Cable-Waiter</b></p> <p>Available in 100 lb. cars</p> <p>Available Finishes &amp; Material: Powder Coated Steel or Stainless Steel</p>	<p><b>Paca-Waiter</b></p> <p>Available in 200 lb., 300 lb. &amp; 500 lb. cars</p> <p>Available Finishes &amp; Material: Powder Coated Steel or Stainless Steel</p>
<p><b>Steel Car with Slide-Up Gate</b></p> 	<p><b>Cable-Waiter</b></p> <p>This Option Is Not Available</p>	<p><b>Paca-Waiter</b></p> <p>Available in 300 lb. &amp; 500 lb. cars</p> <p>Available Finishes &amp; Material: Powder Coated Steel or Stainless Steel</p>



# Commercial Hoistway Door Reference Chart

The door prevents items from accidentally entering the hoistway when the dumbwaiter car is elsewhere. An interlock located at each opening prevents the door from being opened if the dumbwaiter car is not waiting at that landing. We offer the following doors made to your specification. Every opening must have a door.

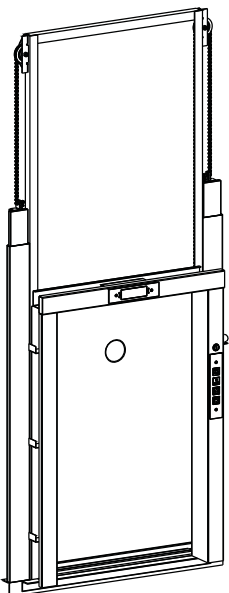
<b>CONSTRUCTION/INSTALLATION NOTE!</b> <b>Hoistway door walls must not be erected until doors are set in place.</b>		
		
Maximum Height of 36"		
<b>Swing Door</b>	<b>Bi-Parting Door</b>	<b>Slide-Up Door</b>
<b>Paca-Waiter</b> 300 lbs. & 500 lbs. Primed Steel or Stainless Steel	<b>Paca-Waiter</b> 300 lbs. & 500 lbs. Primed Steel or Stainless Steel	<b>Paca-Waiter</b> 300 lbs. & 500 lbs. Primed Steel or Stainless Steel

# Residential Mechanical Illustrations

## Cable-Waiter

## Paca-Waiter

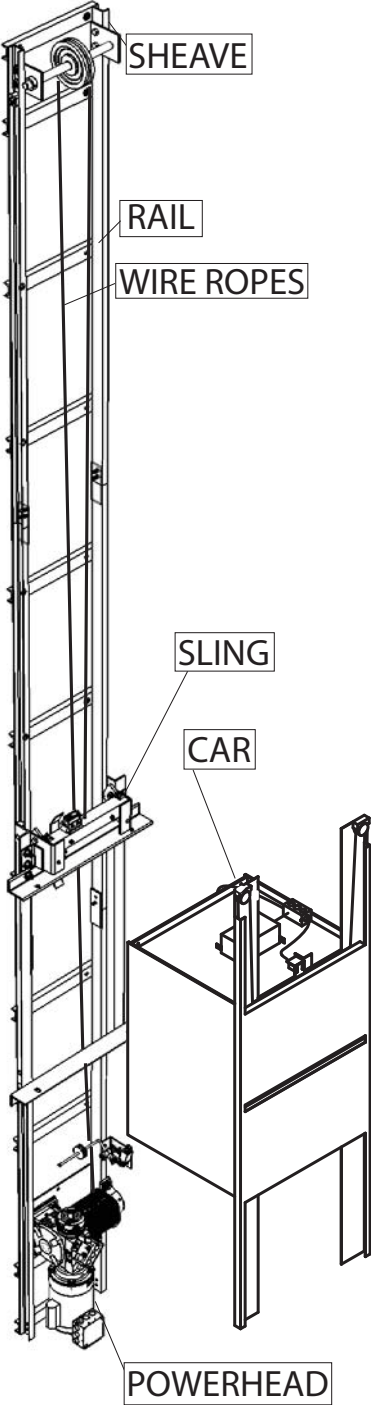
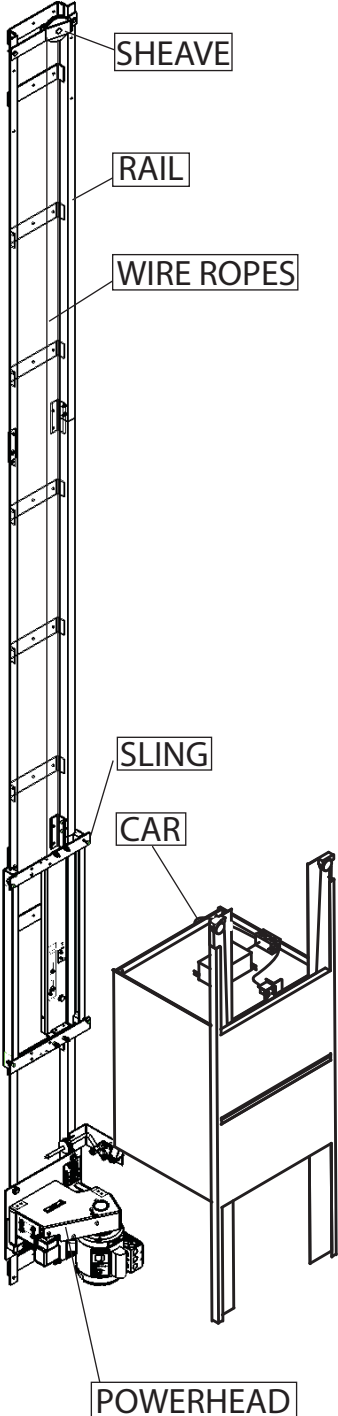

# Commercial Mechanical Illustrations

## Paca-Waiter

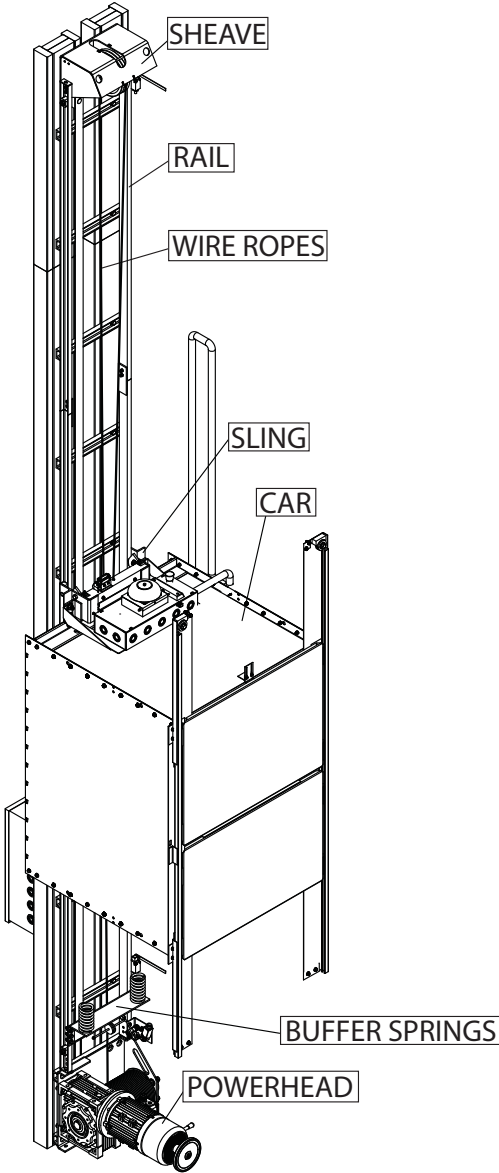

# Elevation Layout - Residential Cable-Waiter

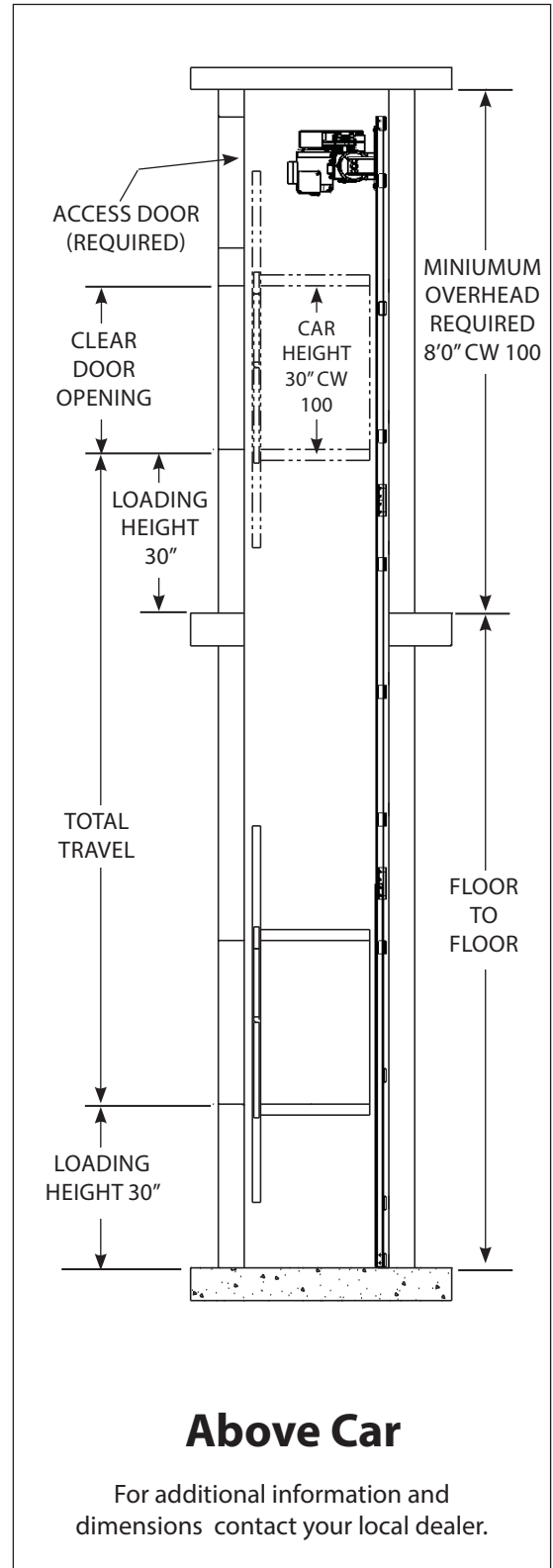
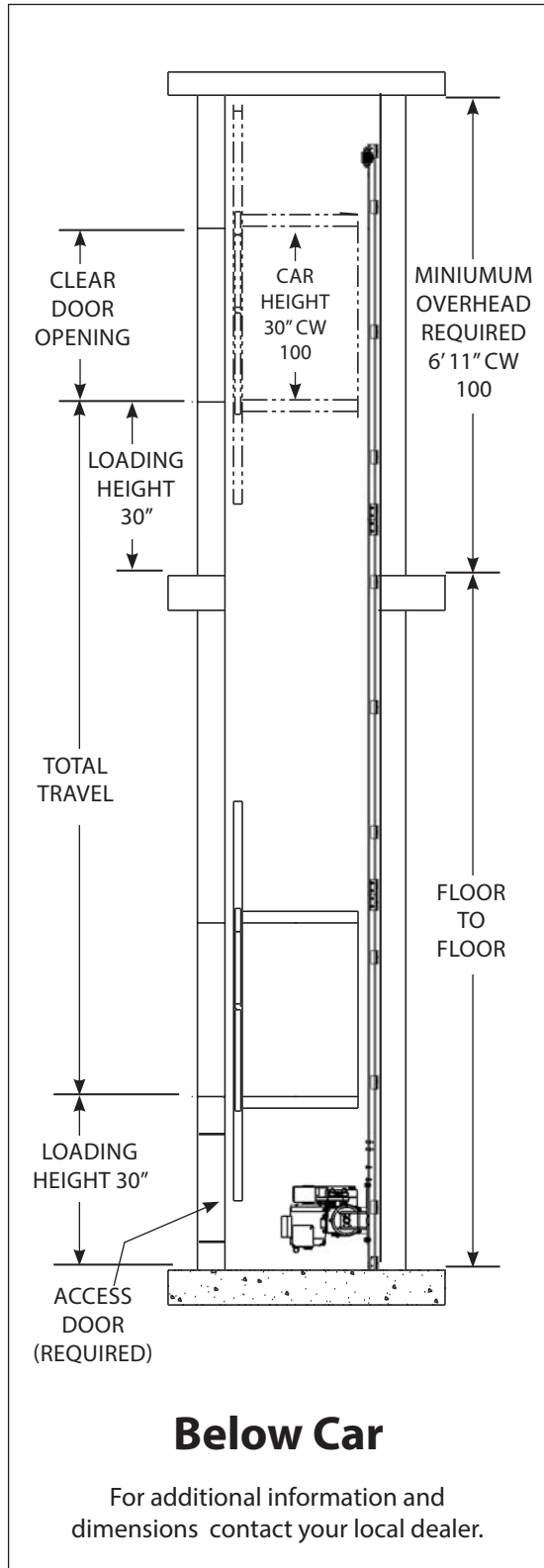

# Elevation Layout - Residential Paca-Waiter

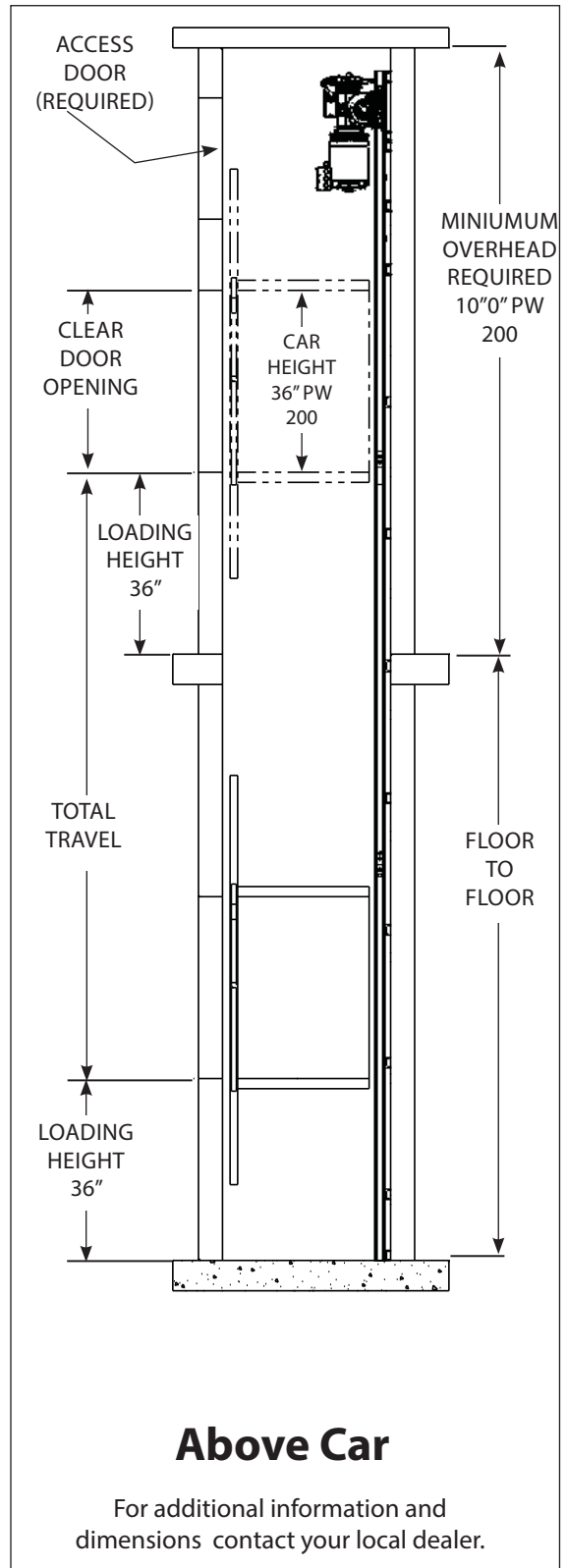
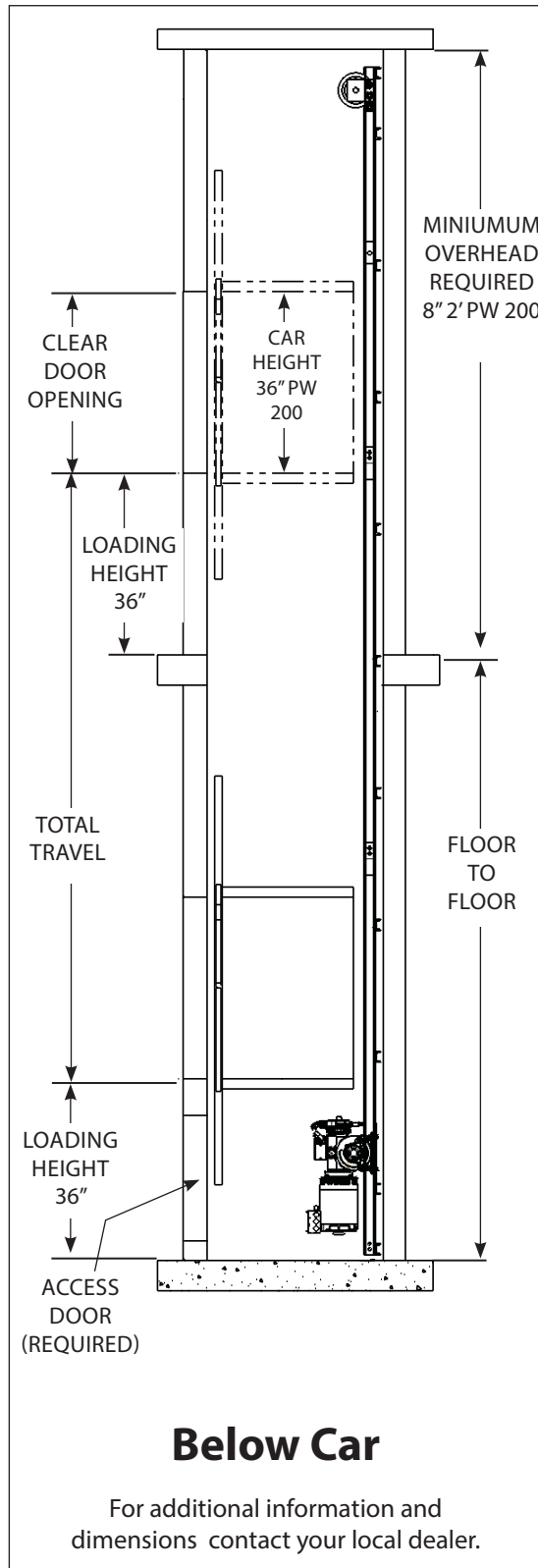

# Elevation Layout - Commercial Paca-Waiter

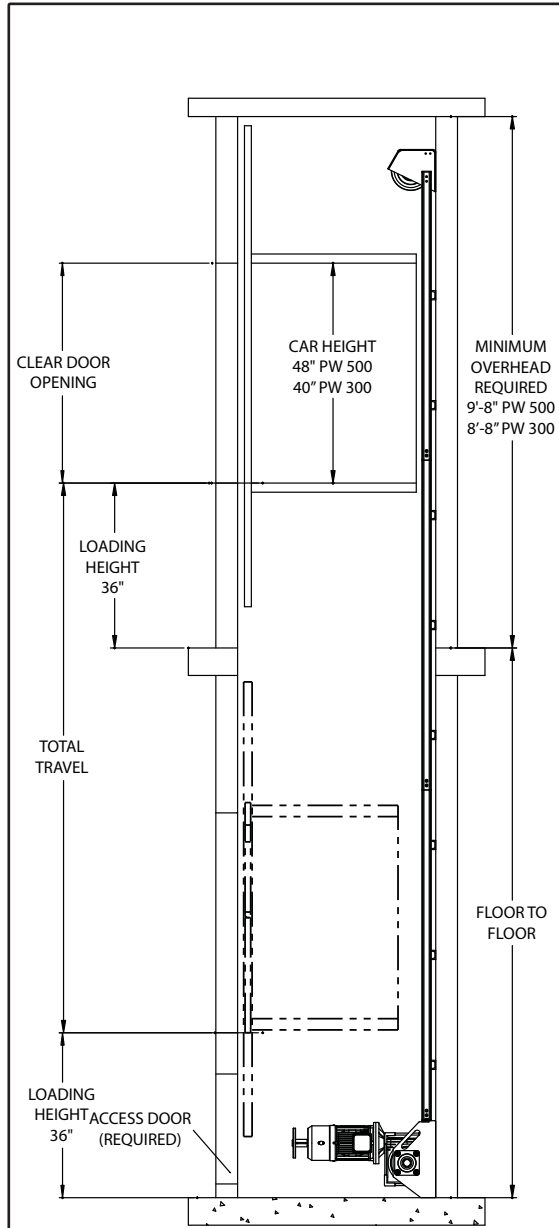

## Below Car

For additional information and dimensions contact your local dealer.

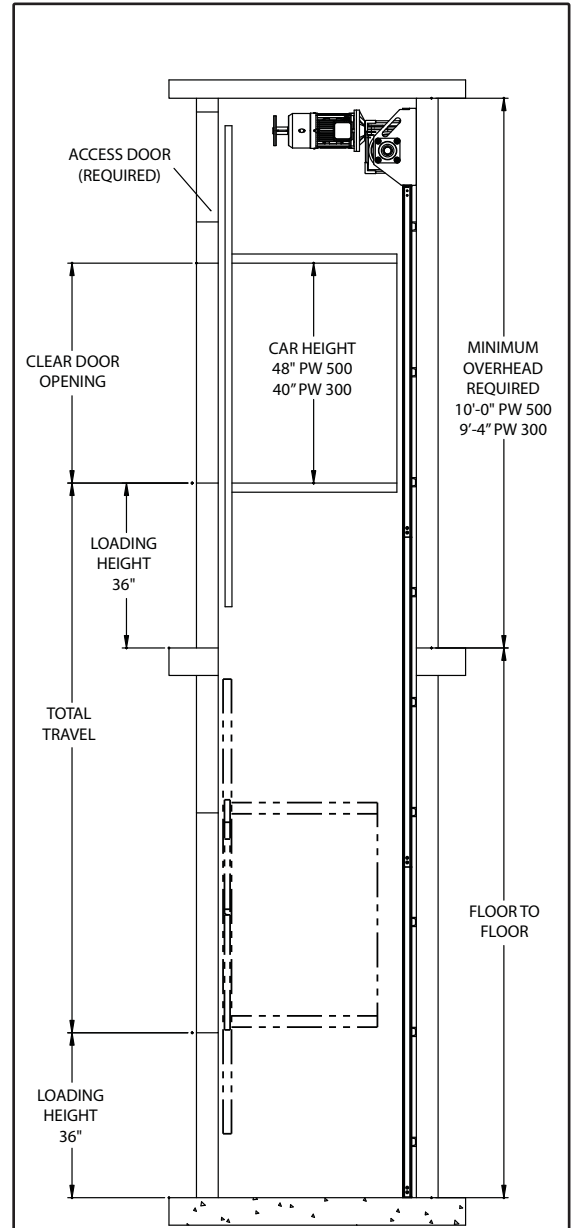

## Above Car

For additional information and dimensions contact your local dealer.

# Electrical Room Layout

Typical Electrical Layout (Layouts may change depending on application)

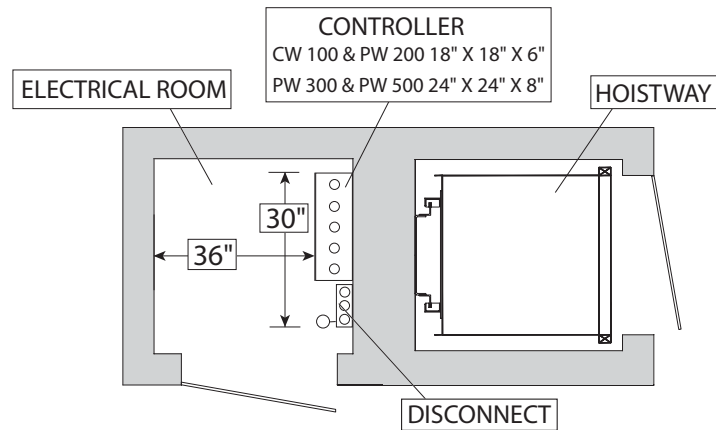

1. Electrical room must meet N.E.C. clear space requirements and all local codes.
2. The controller requires a clear space of 36" x 30" x 6' 6" directly in front.
3. A lockable fusible service disconnect must be placed within sight of the controller and accessible from the latch side of the doorway.
4. Temperature in machine room to be maintained between 60-110° F and must not be exposed to the elements.

# Hoistway Rail Layout

The typical layouts shown here may vary from your actual hoistway. The purpose of these layouts are for a general understanding. Please refer to Waupaca Elevator Company, Inc., drawings and specifications provided by your local dealer.

These drawings depict sample layouts only. It is the responsibility of the installer/contractor or engineer to design and specify structural supports. All construction to be in compliance with local codes.

## Residential Cable-Waiter

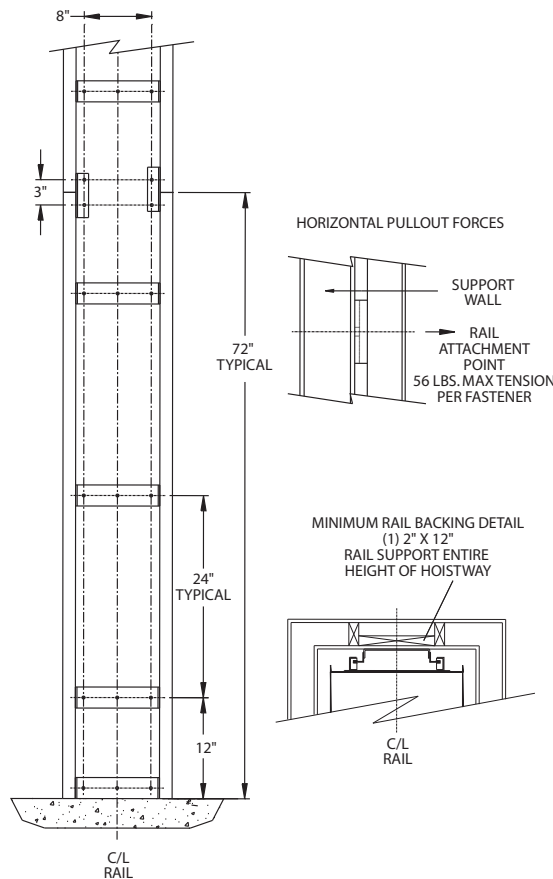

## Residential Paca-Waiter

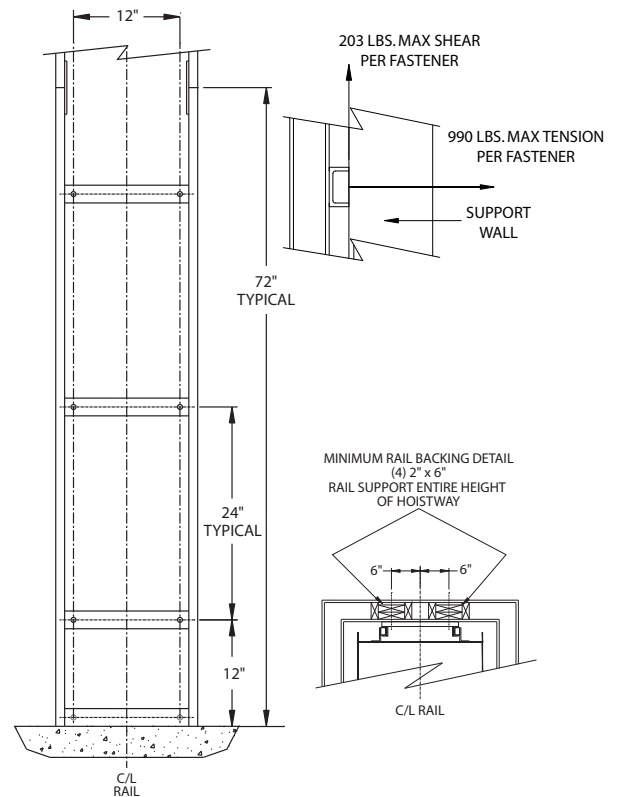

For additional information and dimensions contact your local dealer.



# Hoistway Rail Layout

The typical layouts shown here may vary from your actual hoistway. The purpose of these layouts are for a general understanding. Please refer to Waupaca Elevator Company, Inc., drawings and specifications provided by your local dealer.

These drawings depict sample layouts only. It is the responsibility of the installer/contractor or engineer to design and specify structural supports. All construction to be in compliance with local codes.

## Commercial Paca-Waiter

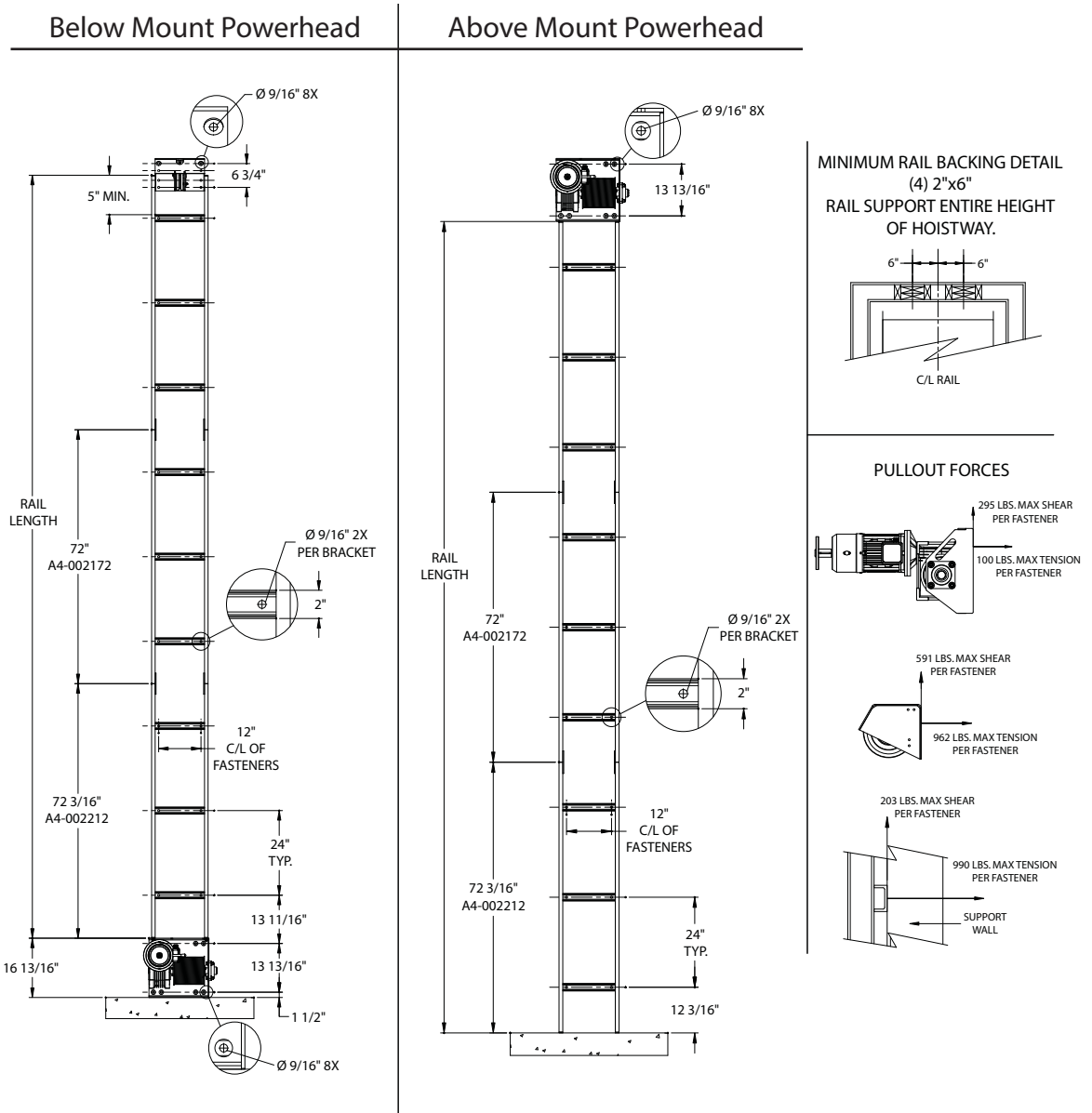

For additional information and dimensions contact your local dealer.

# Hoistway Layout

## Note :

- Dumbwaiter to be installed in accordance with ASME A17.1 Part 7.1, 7.2, and all local codes.
- Electrical room must meet N.E.C. clear space requirements and all local codes.
- Temperature in machine room to be maintained between 60-110° F and must not be exposed to the elements.
- All hoistway doors require an interlock, door handle, and latch set.
- Any alterations to the equipment without written authorization by Waupaca Elevator Company, Inc., will void all warranties.
- Hoistway must be plum within 1/8 inch per 10 ft of height and square at any point within 1/4 inch based on difference in diagonal measurements.
- Structure must be capable of supporting the appropriate loads. Local engineering support is recommended.
- Do not complete door and associated framing to one door (preferably at grade level), until dumbwaiter is completely installed.
- The following hoistway illustrations are showing finished dimensions. Finished hoistway dimensions include drywall, plaster, and paint.
- The following information represented for Cable-Waiter (CW) and Paca-Waiter (PW) units are listed as residential **R** and commercial **C** units.  
Note the appropriate application when considering a dumbwaiter. If the application is appropriate a commercial unit may installed in a residence.

## Car Opening Configurations and Coding

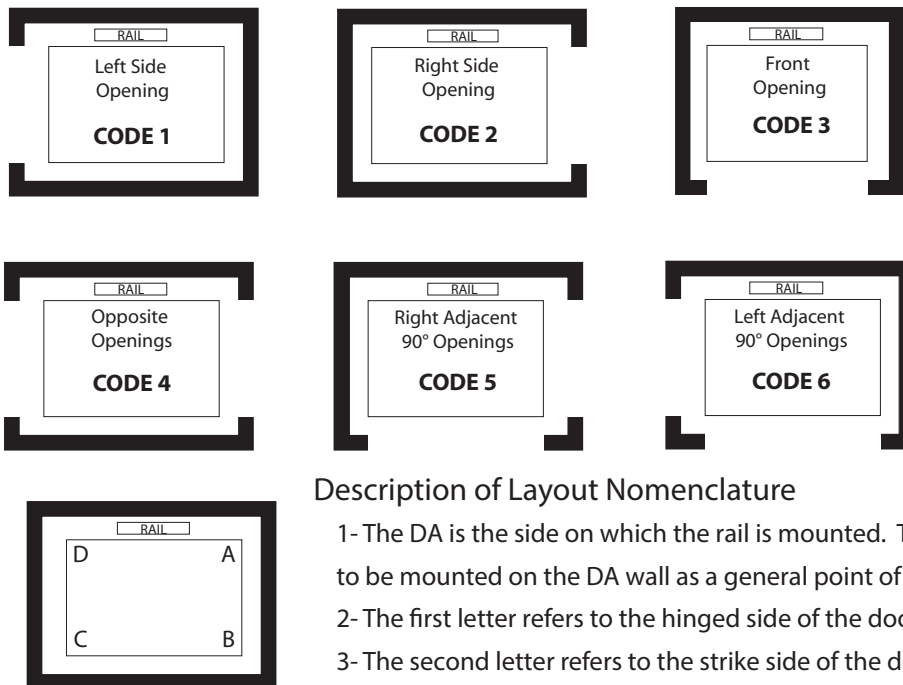

# Hoistway Layout

The dumbwaiters listed in the following section are based upon our standard cars. Dumbwaiter cars can be customized to meet your unique needs in accordance with ASME A17.1.

## Steel Car with Rolltop Gates

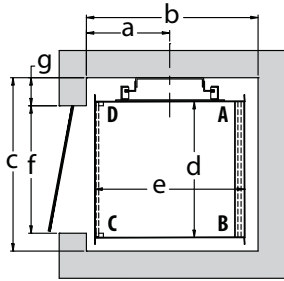

### LEFT OPENINGS (DC) Code 1

Dumbwaiter Type	Car Size	Finished Hoistway Dimensions						
		a	b	c	d	e	f	g
R Cable-Waiter 100 lbs.	20"x20"x30"	12.25"	25.25"	25.5"	20"	22"	18.75"	4.125"
R Paca-Waiter 200 lbs.	26"x26"x36"	15.25"	31.25"	33.25"	26"	28"	24.75"	4.875"
R Paca-Waiter 300 lbs.	30"x30"x40"	17.25"	35.25"	37.25"	30"	32"	28.75"	4.875"

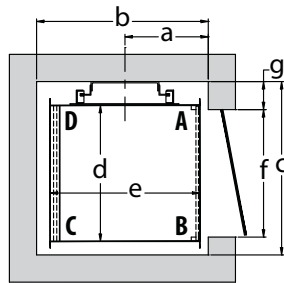

### RIGHT OPENINGS (AB) Code 2

Dumbwaiter Type	Car Size	Finished Hoistway Dimensions						
		a	b	c	d	e	f	g
R Cable-Waiter 100 lbs.	20"x20"x30"	12.25"	25.25"	25.5"	20"	22"	18.75"	4.125"
R Paca-Waiter 200 lbs.	26"x26"x36"	15.25"	31.25"	33.25"	26"	28"	24.75"	4.875"
R Paca-Waiter 300 lbs.	30"x30"x40"	17.25"	35.25"	37.25"	30"	32"	28.75"	4.875"

# Hoistway Layout

The dumbwaiters listed in the following section are based upon our standard cars. Dumbwaiter cars can be customized to meet your unique needs in accordance with ASME A17.1.

## Steel Car with Rolltop Gates

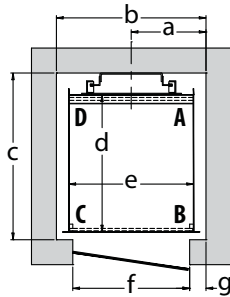

### FRONT OPENINGS (CB) Code 3

Dumbwaiter Type	Car Size	Finished Hoistway Dimensions						
		a	b	c	d	e	f	g
R Cable-Waiter 100 lbs.	20"x20"x30"	12"	24"	26.75"	22"	20"	18.75"	2.625"
R Paca-Waiter 200 lbs.	26"x26"x36"	16"	32"	33.5"	28"	26"	24.75"	3.625"
R Paca-Waiter 300 lbs.	30"x30"x40"	18"	36"	37.5"	32"	30"	28.75"	3.625"

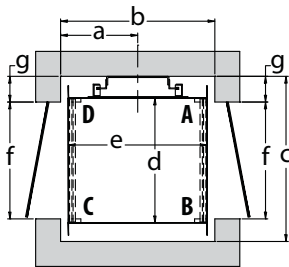

### OPPOSITE OPENINGS (AB DC) Code 4

Dumbwaiter Type	Car Size	Finished Hoistway Dimensions						
		a	b	c	d	e	f	g
R Cable-Waiter 100 lbs.	20"x20"x30"	12.375"	24.75"	26.5"	20"	22.25"	18.75"	4.125"
R Paca-Waiter 200 lbs.	26"x26"x36"	15.375"	30.75"	33.25"	26"	28.25"	24.75"	4.875"
R Paca-Waiter 300 lbs.	30"x30"x40"	17.375"	34.75"	37.25"	30"	32.25"	28.75"	4.875"

# Hoistway Layout

The dumbwaiters listed in the following section are based upon our standard cars. Dumbwaiter cars can be customized to meet your unique needs in accordance with ASME A17.1.

## Steel Car with Bi-parting or Slide-up Gates

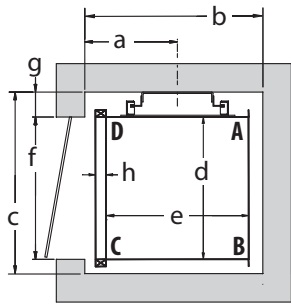

### LEFT OPENING (DC) Code 1

Dumbwaiter Type	Car Size	Finished Hoistway Dimensions							
		a	b	c	d	e	f	g	h
R Cable-Waiter 100 lbs.	20"x20"x30"	13"	25"	25.5"	20"	20"	20"	3.5"	1.5"
R Paca-Waiter 200 lbs.	26"x26"x36"	16"	31"	33.25"	26"	26"	26"	4.25"	1.5"
R Paca-Waiter 300 lbs.	30"x30"x40"	18"	35"	37.25"	30"	30"	30"	4.25"	1.5"
R Paca-Waiter 500 lbs.	36"x36"x48"	21"	41"	43.25"	36"	36"	36"	4.25"	1.5"

\* Slide-up gates not available on CW 100 & PW 200 cars.

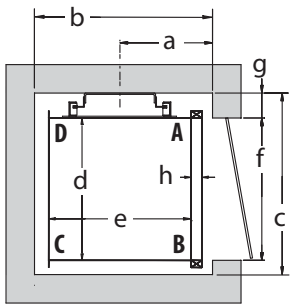

### RIGHT OPENING (AB) Code 2

Dumbwaiter Type	Car Size	Finished Hoistway Dimensions							
		a	b	c	d	e	f	g	h
R Cable-Waiter 100 lbs.	20"x20"x30"	13"	25"	25.5"	20"	20"	20"	3.5"	1.5"
R Paca-Waiter 200 lbs.	26"x26"x36"	16"	31"	33.25"	26"	26"	26"	4.25"	1.5"
R Paca-Waiter 300 lbs.	30"x30"x40"	18"	35"	37.25"	30"	30"	30"	4.25"	1.5"
R Paca-Waiter 500 lbs.	36"x36"x48"	21"	41"	43.25"	36"	36"	36"	4.25"	1.5"

\* Slide-up gates not available on CW 100 & PW 200 cars.

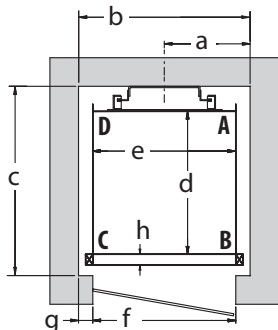

### FRONT OPENING (CB) Code 3

Dumbwaiter Type	Car Size	Finished Hoistway Dimensions							
		a	b	c	d	e	f	g	h
R Cable-Waiter 100 lbs.	20"x20"x30"	12"	24"	26.5"	20"	20"	20"	2"	1.5"
R Paca-Waiter 200 lbs.	26"x26"x36"	16"	32"	33.25"	26"	26"	26"	3"	1.5"
R Paca-Waiter 300 lbs.	30"x30"x40"	18"	36"	37.25"	30"	30"	30"	3"	1.5"
R Paca-Waiter 500 lbs.	36"x36"x48"	21"	42"	43.25"	36"	36"	36"	3"	1.5"

\* Slide-up gates not available on CW 100 & PW 200 cars.

# Hoistway Layout

The dumbwaiters listed in the following section are based upon our standard cars. Dumbwaiter cars can be customized to meet your unique needs in accordance with ASME A17.1.

## Steel Car with Bi-parting or Slide-up Gates

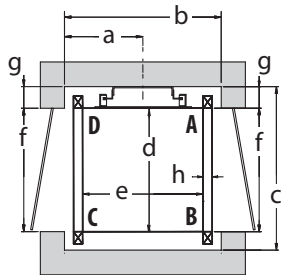

### OPPOSITE OPENINGS (AB DC) Code 4

Dumbwaiter Type	Car Size	Finished Hoistway Dimensions							
		a	b	c	d	e	f	g	h
R Cable-Waiter 100 lbs.	20"x20"x30"	13"	26"	26.5"	20"	20"	20"	3.5"	1.5"
R Paca-Waiter 200 lbs.	26"x26"x36"	16"	32"	33.25"	26"	26"	26"	4.25"	1.5"
R Paca-Waiter 300 lbs.	30"x30"x40"	18"	36"	37.25"	30"	30"	30"	4.25"	1.5"
R Paca-Waiter 500 lbs.	30"x30"x48"	21"	42"	43.25"	36"	36"	36"	4.25"	1.5"

\* Slide-up gates not available on CW 100 & PW 200 cars.

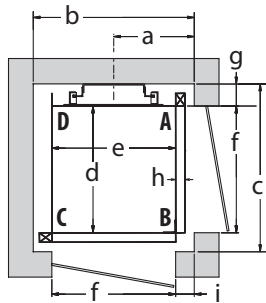

### RIGHT ADJACENT OPENINGS (AB CB) Code 5

Dumbwaiter Type	Car Size	Finished Hoistway Dimensions								
		a	b	c	d	e	f	g	h	i
R Cable-Waiter 100 lbs.	20"x20"x30"	13"	26"	26.5"	20"	20"	20"	3.5"	1.5"	3"
R Paca-Waiter 200 lbs.	26"x26"x36"	16"	32"	33.25"	26"	26"	26"	4.25"	1.5"	3"
R Paca-Waiter 300 lbs.	30"x30"x40"	18"	36"	37.25"	30"	30"	30"	4.25"	1.5"	3"
R Paca-Waiter 500 lbs.	36"x36"x48"	21"	42"	43.25"	36"	36"	36"	4.25"	1.5"	3"

\* Slide-up gates not available on CW 100 & PW 200 cars.

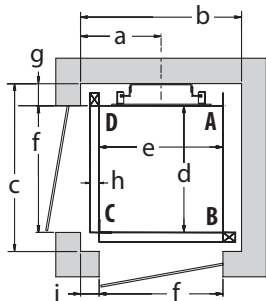

### LEFT ADJACENT OPENINGS (DC BC) Code 6

Dumbwaiter Type	Car Size	Finished Hoistway Dimensions								
		A	B	C	D	E	F	G	H	I
R Cable-Waiter 100 lbs.	20"x20"x30"	13"	26"	26.5"	20"	20"	20"	3.5"	1.5"	3"
R Paca-Waiter 200 lbs.	26"x26"x36"	16"	32"	33.25"	26"	26"	26"	4.25"	1.5"	3"
R Paca-Waiter 300 lbs.	30"x30"x40"	18"	36"	37.25"	30"	30"	30"	4.25"	1.5"	3"
R Paca-Waiter 500 lbs.	36"x36"x48"	21"	42"	43.25"	36"	36"	36"	4.25"	1.5"	3"

\* Slide-up gates not available on CW 100 & PW 200 cars.

# Hoistway Layout

The dumbwaiters listed in the following section are based upon our standard cars. Dumbwaiter cars can be customized to meet your unique needs in accordance with ASME A17.1.

## Steel Car with Bi-parting or Slide-up Gates and Commercial Doors

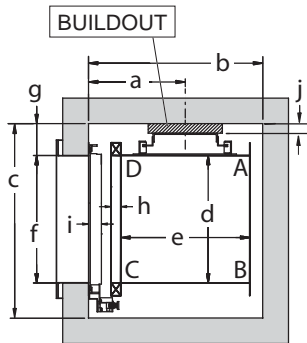

**LEFT OPENING (DC) Code 1**

Dumbwaiter Type	Car Size	Finished Hoistway Dimensions									
		a	b	c	d	e	f	g	h	i	j
<b>C</b> Paca-Waiter 300 lbs.	30"x30"x40"	20"	37"	41.25"	30"	30"	30"	5"	1.5"	2"	.75"
<b>C</b> Paca-Waiter 500 lbs.	36"x36"x48"	23"	43"	47.25"	36"	36"	36"	5"	1.5"	2"	.75"

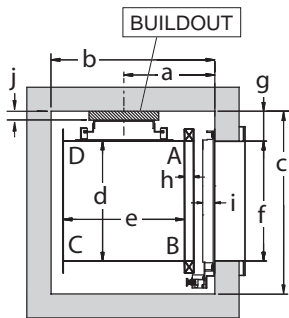

**RIGHT OPENING (AB) Code 2**

Dumbwaiter Type	Car Size	Finished Hoistway Dimensions									
		a	b	c	d	e	f	g	h	i	j
<b>C</b> Paca-Waiter 300 lbs.	30"x30"x40"	20"	37"	41.25"	30"	30"	30"	5"	1.5"	2"	.75"
<b>C</b> Paca-Waiter 500 lbs.	36"x36"x48"	23"	43"	47.25"	36"	36"	36"	5"	1.5"	2"	.75"

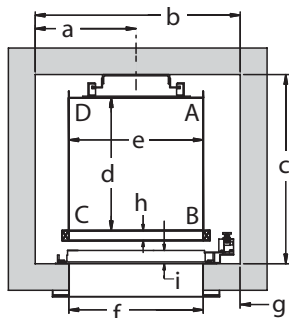

**FRONT OPENING (CB) Code 3**

Dumbwaiter Type	Car Size	Finished Hoistway Dimensions									
		a	b	c	d	e	f	g	h	i	
<b>C</b> Paca-Waiter 300 lbs.	30"x30"x40"	20"	41.25"	39.25"	30"	30"	30"	6.25"	1.5"	2"	
<b>C</b> Paca-Waiter 500 lbs.	36"x36"x48"	23"	47.25"	45.25"	36"	36"	36"	6.25"	1.5"	2"	

# Hoistway Layout

The dumbwaiters listed in the following section are based upon our standard cars. Dumbwaiter cars can be customized to meet your unique needs in accordance with ASME A17.1.

## Steel Car with Bi-parting or Slide-up Gates and Commercial Doors

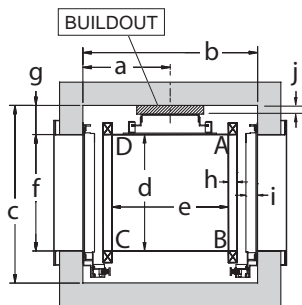

### OPPOSITE OPENINGS (AB DC) Code 4

Dumbwaiter Type	Car Size	Finished Hoistway Dimensions									
		a	b	c	d	e	f	g	h	i	j
<b>C</b> Paca-Waiter 300 lbs.	30"x30"x40"	20"	40"	41.25"	30"	30"	30"	5"	1.5"	2"	.75"
<b>C</b> Paca-Waiter 500 lbs.	36"x36"x48"	23"	46"	47.25"	36"	36"	36"	5"	1.5"	2"	.75"

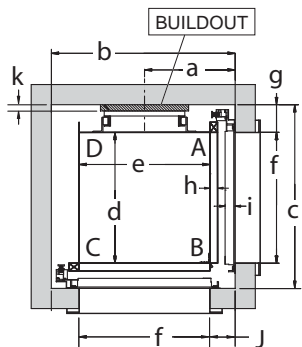

### RIGHT ADJACENT OPENINGS (AB CB) Code 5

Dumbwaiter Type	Car Size	Finished Hoistway Dimensions										
		a	b	c	d	e	f	g	h	i	j	k
<b>C</b> Paca-Waiter 300 lbs.	30"x30"x40"	20"	41.25"	41.25"	30"	30"	28"	6.25"	1.5"	2"	7"	2"
<b>C</b> Paca-Waiter 500 lbs.	36"x36"x48"	23"	47.25"	47.25"	36"	36"	34"	6.25"	1.5"	2"	7"	2"

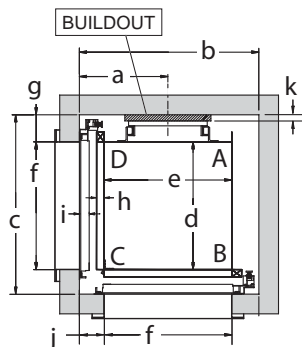

### LEFT ADJACENT OPENINGS (DC BC) Code 6

Dumbwaiter Type	Car Size	Finished Hoistway Dimensions										
		a	b	c	d	e	f	g	h	i	j	k
<b>C</b> Paca-Waiter 300 lbs.	30"x30"x40"	20"	41.25"	41.25"	30"	30"	28"	6.25"	1.5"	2"	7"	2"
<b>C</b> Paca-Waiter 500 lbs.	36"x36"x48"	23"	47.25"	47.25"	36"	36"	34"	6.25"	1.5"	2"	7"	2"

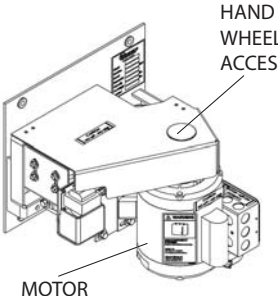
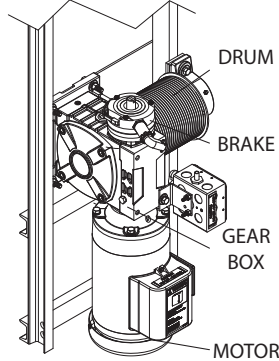
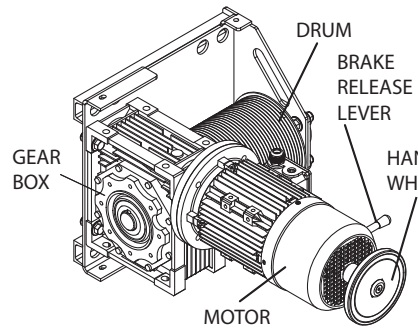
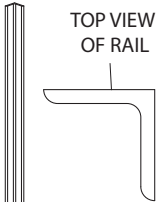
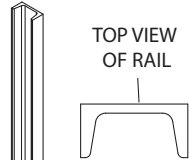
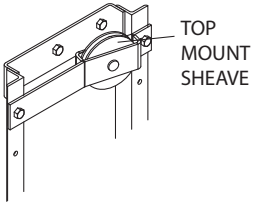
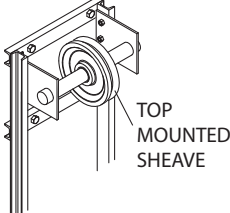
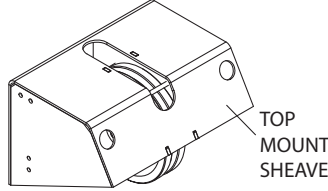

# Typical Dumbwaiter Equipment

Cable-Waiter	Paca-Waiter	
RESIDENTIAL UNIT	RESIDENTIAL UNIT	COMMERCIAL UNIT
 <p>HAND WHEEL ACCESS</p> <p>MOTOR</p>	 <p>DRUM</p> <p>BRAKE</p> <p>GEAR BOX</p> <p>MOTOR</p>	 <p>DRUM</p> <p>BRAKE RELEASE LEVER</p> <p>HAND WHEEL</p> <p>GEAR BOX</p> <p>MOTOR</p>
 <p>TOP VIEW OF RAIL</p> <p>MAIN RAIL: 1-1/2" X 1-1/2" X 1/8" ANGLE STEEL</p>	 <p>TOP VIEW OF RAIL</p> <p>MAIN RAIL: 2" X 1" X 3/16" C-CHANNEL STEEL</p>	
 <p>TOP MOUNT SHEAVE</p>	 <p>TOP MOUNTED SHEAVE</p>	 <p>TOP MOUNT SHEAVE</p>

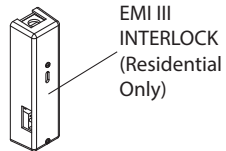

EMI III INTERLOCK (Residential Only)

HOISTWAY DOOR INTERLOCKS: REQUIRED AT EACH OPENING TO PREVENT HOISTWAY ACCESS WHILE DUMBWAITER IS OPERATING OR AT ANOTHER LANDING.

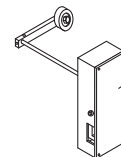

GAL TYPE "SN & N" INTERLOCK





1726 North Ballard Road, Suite 1 • Appleton, WI 54911  
Phone 920-991-9082 • [www.waupacaelevator.com](http://www.waupacaelevator.com)

PMQ0400-K  
13 JUN 2018