



Smart Spa Remote Installation Guide

Alexa-Jandy 4

January 2022

For assistance contact us:

Support@smartsparemote.com

1	INSTALLING THE SMART SPA REMOTE – JANDY/ALEXA CIRCUIT BOARD	3
2	SETTING UP SMART SPA REMOTE	6
3	CONFIGURING SMART SPA REMOTE DISCOVERED DEVICES:	13
3.1	How to Configure Alexa discovered devices	13
3.2	Creating automated routines	18
3.3	Jandy RS Controller setup	20
3.4	Troubleshooting	24

*Use or disclosure of information contained in this page strictly prohibited
Smart Spa Remote Confidential and Proprietary Commercial Information*

1 Installing the Smart Spa Remote – Jandy/Alexa circuit board

- Watch the video on installing the Smartspa remote Jandy 4 www.Smartsparemote.com
- Connect the Smart Spa Remote circuit board as shown below

To avoid damaging the Smart(Alexa) Spa Remote PCB from Static Electricity
Steps:

- Please wear **shoes with rubber soles**
- **avoid dragging board**
- **hold board on green sections only**
- **avoid touching components**
- **LASTLY TURN THE JANDY OFF BY UNPLUGGING FROM POWER/BREAKER**
 - Connect the Spa control wires 1st – You are inserting the smart spa remote wires along with the existing jandy wires. Loosen the screw and insert along with existing wires. Follow the wire color code and hole locations as described in the picture below.
 - Connect the Temp Control and Pentair Temp Sensor, see below, red to red and black to black, Then also connect the circuit board black to the temp sensor black screw.
 - Connect the Power as shown below, red led will light up with power connected to Jandy.
 - Place circuit board in controller where you can extend the external antenna to the outside of the Jandy Control Box, We recommend putting sticky tape on back of board and mounting to left inside of aqualink metal enclosure so that antenna can extend out one of the bottom cut outs.
 - Connect the Smart Spa Remote PCB Temp Monitor wire to either pool or spa black (#5 or #3) depending on where you connect the temperature sensor **FIGURE X** to the jandy.

Wiring Diagram Figure Below

*Use or disclosure of information contained in this page strictly prohibited
Smart Spa Remote Confidential and Proprietary Commercial Information*

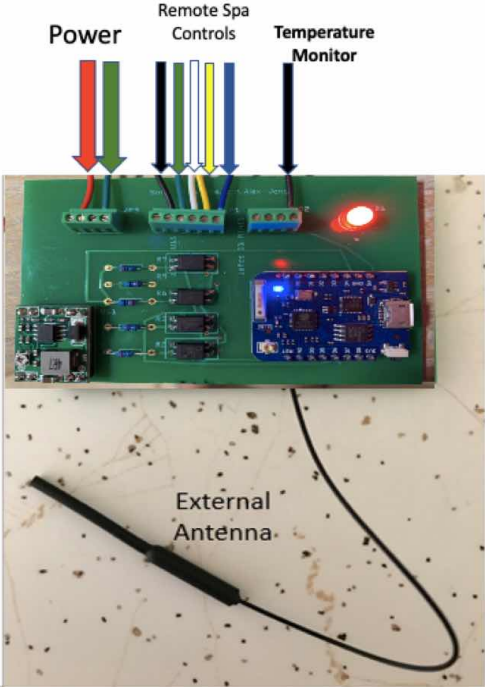
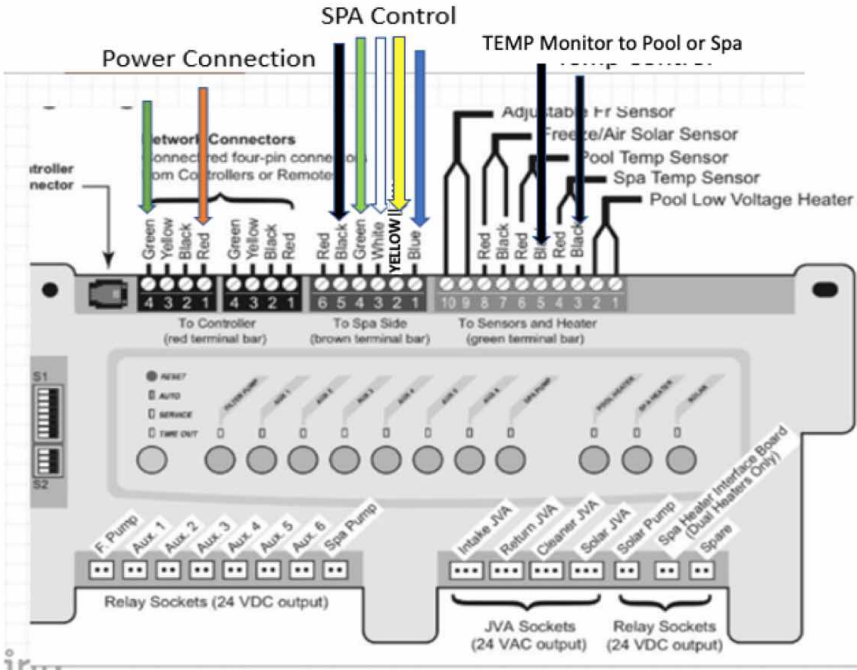

Use or disclosure of information contained in this page strictly prohibited
Smart Spa Remote Confidential and Proprietary Commercial Information

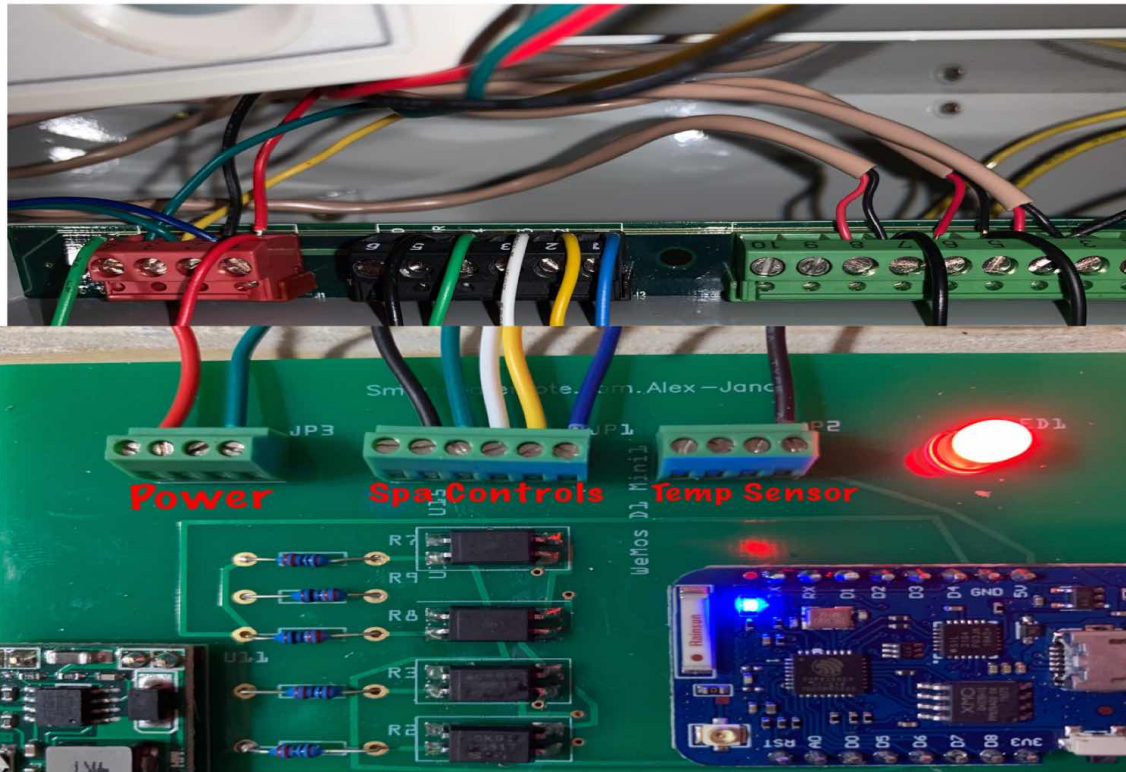

Smart Spa Remote Temp Sensor Black wire to Jandy Green Terminal, pin hole #5.
Smart Spa Remote 5 Spa Controls wires to Jandy Black Terminal, pin holes #1-#5.
Blue to pin hole #1, Yellow to pin hole #2, White to pin hole #3, Green to pin hole #4, Black to pin hole #5
Smart Spa Remote Power wires to Jandy Red Terminal, pin holes #1 and #4, Red wire to hole #1 and Green wire to hole #4.

*Use or disclosure of information contained in this page strictly prohibited
Smart Spa Remote Confidential and Proprietary Commercial Information*

2 Setting Up Smart Spa Remote

Once the Smart Spa Remote circuit board has been installed you will want to begin the software setup and configuration.

1. *Power on the Smart Spa Remote by plugging in the power as shown in figure 1 above. You should see a red light on the circuit board. Once the red power led is on you may proceed to configuring Alexa to discover the pool devices.*
2. *Configure the smart Spa Remote by using your smart phone. Confirm the smartphone has access to the home owner wifi by entering setup on your phone. If you don't see the homeowner wifi displayed when scanning for SSID's you will need the home owner to add a range extender inside the home near the Jandy Aqualink.*
3. *The smart Spa Remote PCB once powered up will begin broadcasting as a hot spot with the name "pooltimer".*
4. *You will select **pooltimer** SSID from your phone.*

*Use or disclosure of information contained in this page strictly prohibited
Smart Spa Remote Confidential and Proprietary Commercial Information*

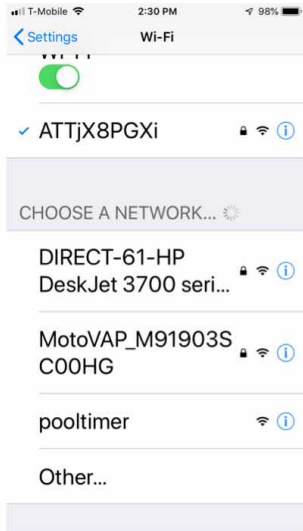

Once initially selected the smart Spa Remote will try to connect over the internet so that it can communicate with Alexa and Smart Spa Remote as part of the registration process. Once you select the pooltimer SSID the phone should automatically launch a configuration screen from your default browser. If the browser does not appear you may begin the registration process by going to your favorite web browser like Chrome or Safari.

1. Enter **pooltimer.local/** into the browser where you would normally enter something like <http://www.test.com>

*Use or disclosure of information contained in this page strictly prohibited
Smart Spa Remote Confidential and Proprietary Commercial Information*

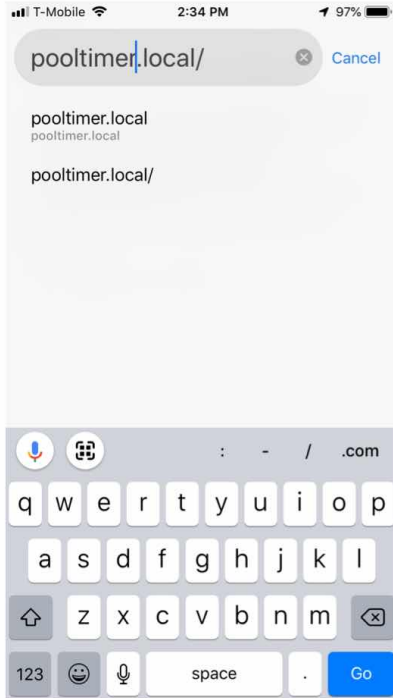

2. Once you enter **pooltimer.local/** a screen will pop up that will allow you to enter the correct wifi SSID for the home where you have installed the smart Spa Remote. You will want to verify the SSID and password on your own phone 1st to insure the SSID is accessible from the location of the smart Spa Remote.

Smartsparemote only supports 2.4ghz WIFI do not use a 5ghz SSID

See Below:

*Use or disclosure of information contained in this page strictly prohibited
Smart Spa Remote Confidential and Proprietary Commercial Information*

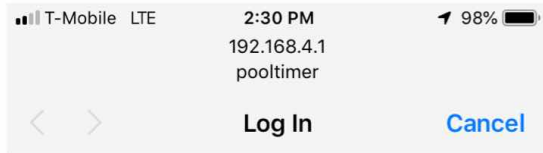

pooltimer

WiFiManager

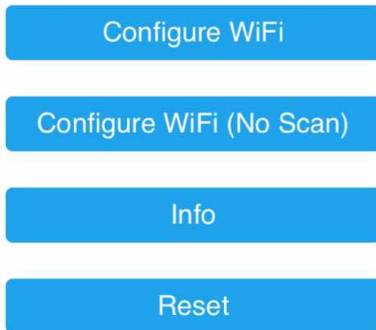

1. Select Configure Wifi, this will cause the Smart Spa Remote to begin scanning for SSID's. It will show signal strength. If the SSID of the homeowner does not appear you do not have a strong enough signal to complete the install. You will need to have the home owner acquire a SSID signal enhancer inside the home near where you are installing the smart Spa Remote.
2. When your SSID appears, you will select it. In this sample case it is ATTjX8PGX.

*Use or disclosure of information contained in this page strictly prohibited
Smart Spa Remote Confidential and Proprietary Commercial Information*

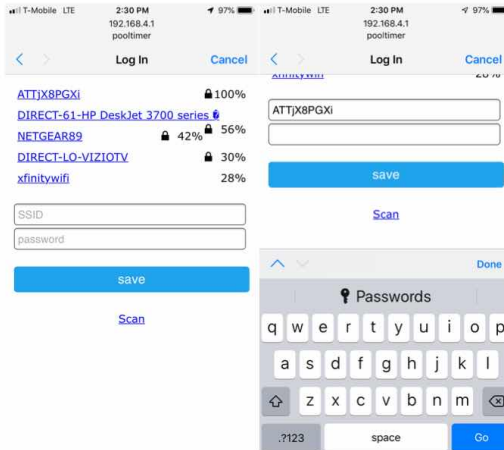

1. Once you select your SSID the screen automatically fills in the SSID with your selection. It will then tab to password where you will enter your SSID password and select the “SAVE” button.
2. This will allow the Smart Spa Remote to logon to the smart Spa Remote server and discover the devices you will now activate in the Amazon Alexa App. A blue led will light up on the smart spa circuit card when connected. If the Blue LED does not light up you will need to verify you entered the correct SSID and Password. Then once connected (blue led is on) you will need to download the **Amazon Alexa app** to your phone.
3. **Note :** If the blue light occasionally goes off it is an indication your wifi signal at the Jandy Power center is not strong enough. Wifi does not penetrate walls very well, we recommend you add a wifi range extender near your Jandy power center to boost the wifi signal to insure the Smart Spa Remote remains connected to the Alexa server.
4. You will need to use your (homeowners) Amazon sign on to link the Amazon Alexa App to the Smart Spa Remote. If the homeowner doesn’t have an amazon account, you will need to create a new “**amazon account**” see below:

*Use or disclosure of information contained in this page strictly prohibited
Smart Spa Remote Confidential and Proprietary Commercial Information*

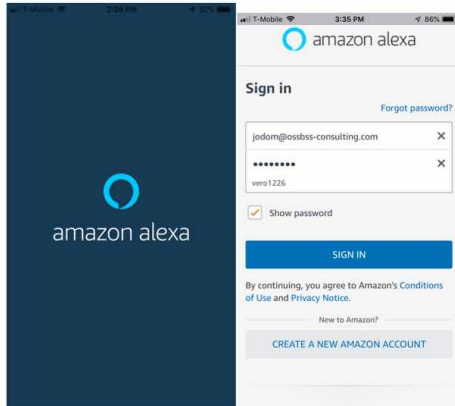

1. Once the account has been created, sign on to your amazon Alexa app. You will then see a screen to configure Alexa, see below”. Before you can add devices, you need to add a Smart Skill, select enable smart home skills and search for “SMART SPA REMOTE”. This will allow Alexa to discover the Smart Spa Remote devices.

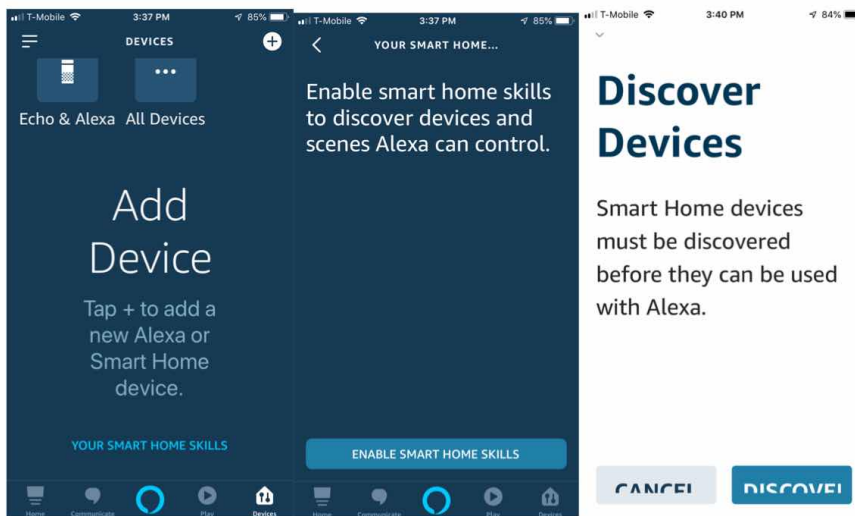

2. The Enable Screen will appear, select enable to use.

*Use or disclosure of information contained in this page strictly prohibited
Smart Spa Remote Confidential and Proprietary Commercial Information*

3. Enter the email and password that comes with your Smart Spa Remote. Each Smart Spa Remote will have a unique email and password and will be taped on the Smart Spa Remote unit.
4. Enter login and you should then see the screen that Smart Spa Remote has been successfully linked.

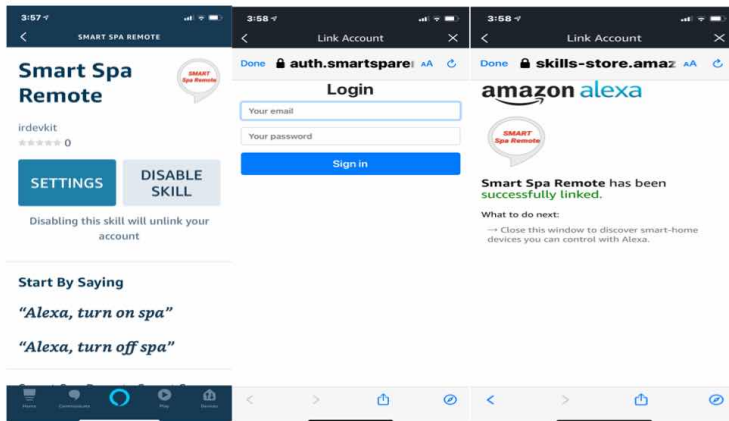

5. Now that the Smart Spa Remote has been successfully linked to Alexa its time for Alexa to discover the Smart Spa Remote devices. Select Discover button. You will see Alexa discovering devices. You should see 5 devices discovered. 4 Spa/Pool Functions and 1 Pool/Spa Temperature sensor.

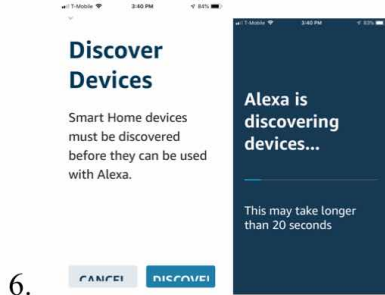

- 6.

*Use or disclosure of information contained in this page strictly prohibited
Smart Spa Remote Confidential and Proprietary Commercial Information*

3 Configuring Smart Spa Remote Discovered Devices:

3.1 How to Configure Alexa discovered devices

The Smart Spa Remote contains:

Discovered Devices (5)

Note : Occasionally Alexa will say no devices discovered when it actually did, if this happens select the devices tab at the bottom of the Alexa app. It should then display the new devices.

Relays #1-#4 plus Temperature Sensor

- 4 Button Spa Remote Functions(Smart Alexa Spa Remote) emulated
 - These functions can be configured for your requirements
 - Button 1 comes set for Spa/Pool mode
 - Button 2 is set for Heater
 - Button 3 is set for Aux 1
 - Button 4 is set for Aux 2
 - Temperature Sensor is set for Spa/Pool

- The new Alexa names may not match the Jandy feature, for example Pool Pump on Alexa app turns on the Jandy Spa Pump. This is normal and you will want to map the Jandy to the Alexa app.
 - 1st
 - Program the Jandy Spalink buttons 1-4 for the features you want Alexa to manage, see video at www.smartsparemote.com How to program the Jandy. The instructions are also in section 3.3 of this manual.
 - 2nd
 - Select each of the devices in the Alexa app on/off, note what actual Jandy feature is activated. Then go in the Alexa app and edit the Alexa name to match the feature. See below:

*Use or disclosure of information contained in this page strictly prohibited
Smart Spa Remote Confidential and Proprietary Commercial Information*

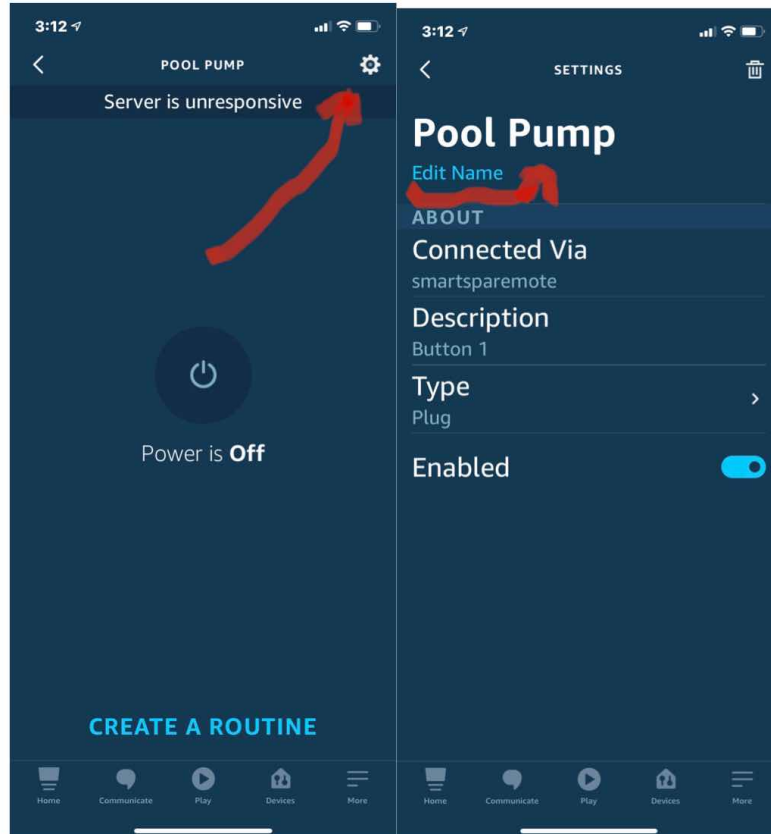

- Remember you can change any of these names in the Alexa app, for the Temperature Sensor you can ask Alexa “ What is the Spa Temperature” so just use the name spa for the sensor and Alexa already knows it is a temperature sensor so that is what allows you to say Alexa “ What is the Spa Temperature?”, if you are monitoring the pool then change the sensor to Pool.

SEE PICTURE BELOW

*Use or disclosure of information contained in this page strictly prohibited
Smart Spa Remote Confidential and Proprietary Commercial Information*

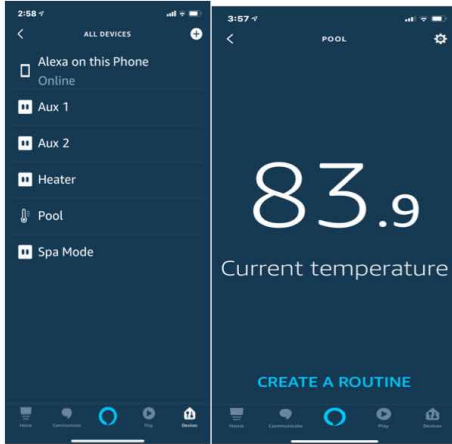

- Alexa feature status may not match Jandy feature. For example, if you turn Aux 3 on at the Jandy console the Alexa app has no way to know this feature is on and therefore could show off. The Jandy 4 emulates the RS4 Spa Side remote, this device provides no feedback status, it simply toggles a device pushbutton which in turn results in on/off.
 - We recommend you manually sync the Alexa app with the Jandy. Simply view the Alexa app and then manually change the Jandy feature to match the alexa app by pressing the appropriate button on/off via the Jandy console. Then set up Alexa routines to turn features on/off.



*Use or disclosure of information contained in this page strictly prohibited
Smart Spa Remote Confidential and Proprietary Commercial Information*

○ Jandy Remote Spa Control Defaults

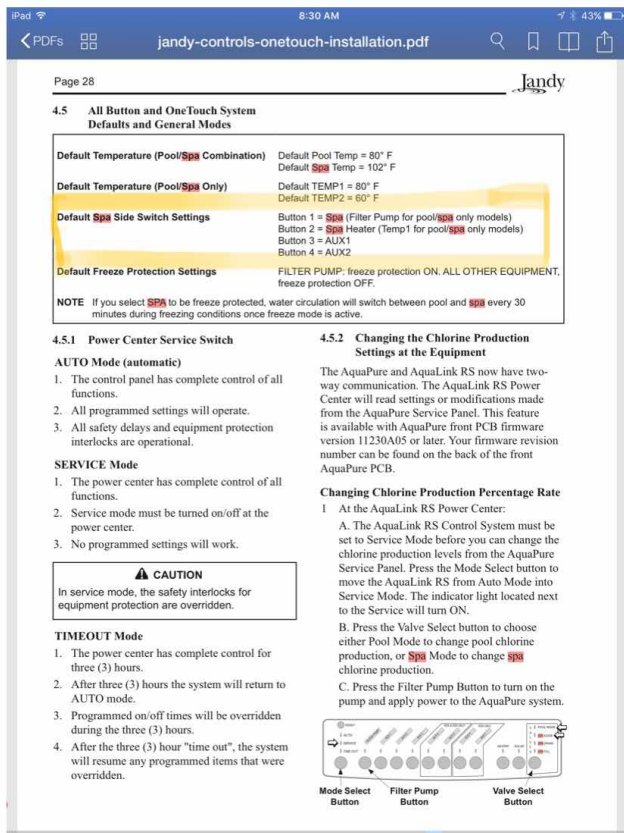

- 1 Pool Temperature Gauge
 - 2 wire connection for **Jandy Water Temp Sensor with 20' Cable**
 - **This can be purchased with instructions on Amazon**

*Use or disclosure of information contained in this page strictly prohibited
Smart Spa Remote Confidential and Proprietary Commercial Information*



1. Configure the discovered devices to match your specific needs. **You may want to rename** Function 1 to Spa Mode and Function 2 as Spa Lights as examples to match how you have configured the Aqualink Spa Side Switch Settings.
2. See example screens below:
 - a. Select Spa Function 1, then select the round nut icon in the top right portion of the screen.
 - b. Then Select Edit Name
 - c. Then type in the name you wish to use "Spa Mode"
 - d. Continue to do this for any discovered device for which you want to change the name

*Use or disclosure of information contained in this page strictly prohibited
Smart Spa Remote Confidential and Proprietary Commercial Information*



3.2 Creating automated routines

1. Set Spa Lights

To set automated routines for the devices you will create a routine. This will allow you to set automated times for the pool equipment to come on and off. You may want the Spa Lights to come on at 3am and go off at 11am. Create a routine for that devices. Put a 5 second delay between steps to give the Alexa app time to communicate to the Jandy.

See below:

*Use or disclosure of information contained in this page strictly prohibited
Smart Spa Remote Confidential and Proprietary Commercial Information*

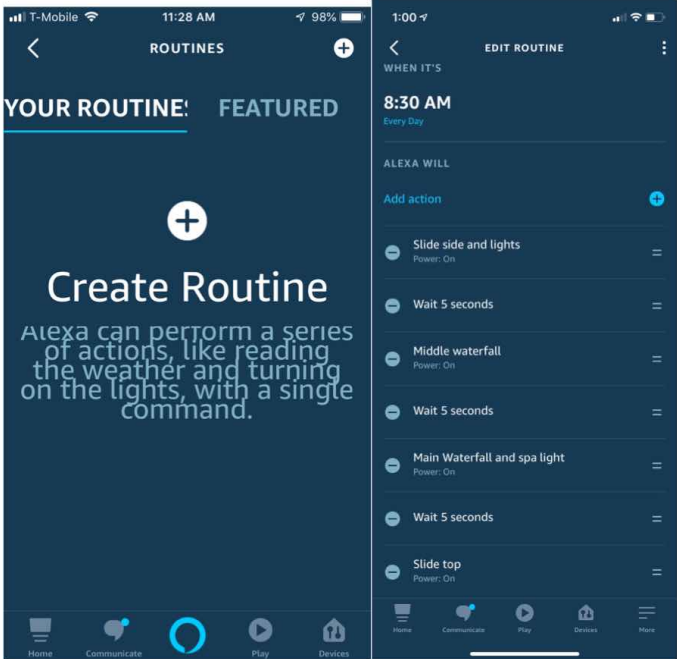

*Use or disclosure of information contained in this page strictly prohibited
Smart Spa Remote Confidential and Proprietary Commercial Information*

3.3 Jandy RS Controller setup to support the Spa Switch(Jandy 4)

Setup using the All in One keypad

Spa Side Switch Menu

The Spa Side Switch menu allows you to define which equipment is controlled by the buttons (4 buttons per Spa Side Switch) on the optional Spa Side Switch(es).

You may want to write down your spa side switch button assignments so that you can label the buttons on the switch with the label pack provided.

To set the Spa Side Switch buttons

1. Press the MENU button, then press the FORWARD button and scroll through until you reach SYSTEM SETUP. Press ENTER then press FORWARD to SPA SWITCH. Press ENTER again. The display will read 1 SWITCH <—>*. Use the FORWARD and BACK arrows to move between 1 SWITCH, 2 SWITCHES and 3 SWITCHES. Depending on how many Spa Side Switches you have, choose an option and press ENTER.
2. The AquaLink RS display will read SELECT DEVICE FOR BUTTON 1. Press the button on the Controller for the piece of equipment that you want to control from the first button of the Spa Side Switch (for example, press the Spa button).
3. Repeat this process for each remaining button on the Spa Side Switch. When you are finished, the AquaLink RS display will show the settings for each button.

NOTE If there is more than one Spa Side Switch on the system, the buttons on the second switch will be buttons 5-8, and the buttons on the third Spa Side Switch will be buttons 9-12.

*Use or disclosure of information contained in this page strictly prohibited
Smart Spa Remote Confidential and Proprietary Commercial Information*

Setup using the One Touch keypad

Spa Side Switch Menu

The Spa Side Switch menu allows you to define which equipment is controlled by the buttons on the optional Spa Side Switch(es). Default settings are spa, spa heat, Aux1 and Aux2.

You may want to write down your spa side switch button assignments so that you can label the buttons on the switch with the label pack provided.

To set the Spa Side Switch

Highlight MENU/HELP and press SELECT, highlight SYSTEM SETUP and press SELECT, highlight SPA SWITCH and press SELECT. Inside the SPA SWITCH menu, highlight the number of Spa Side Switches you have and press SELECT. Use the UP/DOWN arrow keys to move the highlight bar to choose which button you are assigning, press SELECT. Use the UP/DOWN arrow keys to move the highlight bar to choose which piece of equipment will be associated with the button, press SELECT. After pressing SELECT on the piece of equipment, you will be returned one screen to continue assigning Spa Side Switch buttons.

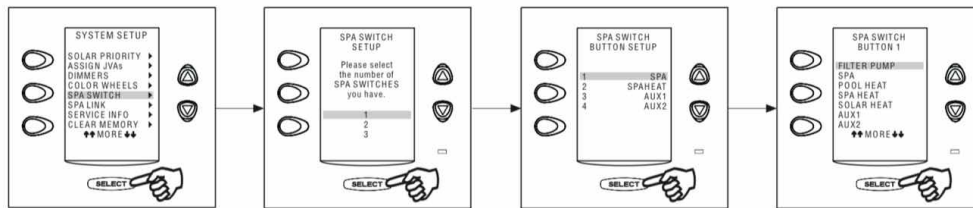

*Use or disclosure of information contained in this page strictly prohibited
Smart Spa Remote Confidential and Proprietary Commercial Information*

Setup using the PDA

6.11 Spa Side Switch Menu

The spa side switch menu allows you to define which equipment is controlled by the buttons on the optional spa side switch(es). Default settings are spa, spa heat, aux1 and aux2.

You may want to write down your spa side switch button assignments so that you can label the buttons on the switch with the label pack provided.

6.11.1 To set the Spa Side Switch

NOTE The PDA system supports only one spa side switch and does not support the SpaLink RS.

Highlight MENU and press SELECT, highlight SYSTEM SETUP and press SELECT, highlight SPA SWITCH and press SELECT. Use the UP/DOWN arrow keys to move the highlight bar to choose which button you are assigning, press SELECT. Use the UP/DOWN arrow keys to move the highlight bar to choose which piece of equipment will be associated with the button, press SELECT. After pressing SELECT on the piece of equipment, you will be returned one screen to continue assigning Spa Side Switch buttons.

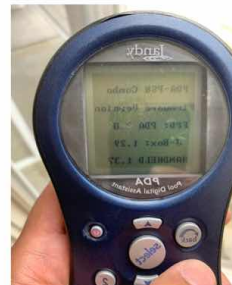
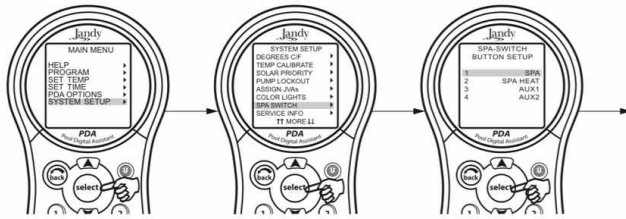

*Use or disclosure of information contained in this page strictly prohibited
Smart Spa Remote Confidential and Proprietary Commercial Information*

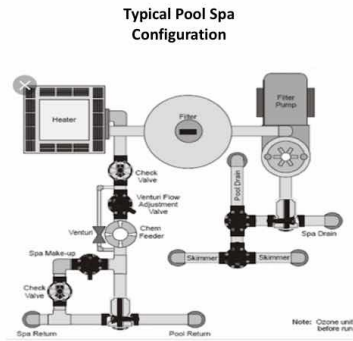

Example Picture of Compatible Jandy controllers where you will need to also purchase the Jandy Spa 6-pin connector

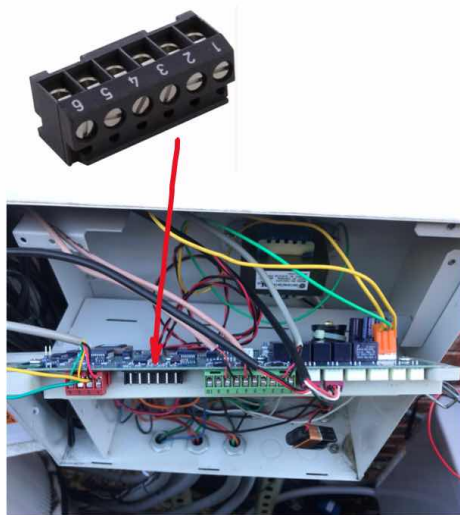

*Use or disclosure of information contained in this page strictly prohibited
Smart Spa Remote Confidential and Proprietary Commercial Information*

3.4 Troubleshooting

	RED LED OFF	Red LED ON BLUE LED OFF	Red LED and Blue LED ON	
Server Unresponsive Message in Alexa	There is no power to the PCB, check power Red and Green wires going to Jandy 4 pin connector	You have lost connection to the Alexa Server – Verify you have Wifi Signal then press reset button on PCB – see image below	Try resetting PCB if the problem persists notify Smart Spa Remote via text message to: 772-237-0506	
Blue light goes on for a period of time and then off		You generally need 3 or 4 bars of consistent wifi signal to maintain connection to the server. Wifi does not penetrate walls very well. Recommend putting extension on PCB Antenna and extending antenna outside of Jandy Power Center closer to Wifi equipment or add Wifi repeater to your home getting the access point closer to the jandy power center		
Temperature shows 400+ degrees			This is a bad wire connection between the PCB Temp Sensor connection and Jandy Power Center. Check both ends to insure a good connection. Jandy Power Center needs to be on 10 pin connection #7 for air, #5 for pool or #3 for spa temperatures. You can change locations to see if the temperature changes. If so you likely have a bad Jandy Temp Sensor	
No devices discovered			Sometimes Alexa will display this message even though the devices are discovered. Go to devices tab at bottom of Alexa screen. The devices should show up there.	

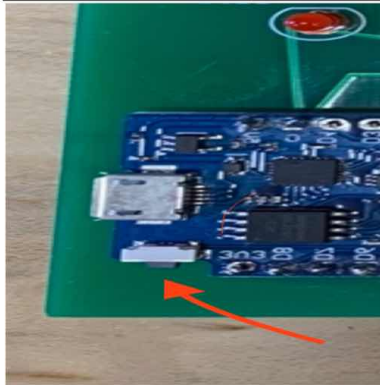

PCB RESET BUTTON

*Use or disclosure of information contained in this page strictly prohibited
Smart Spa Remote Confidential and Proprietary Commercial Information*

*Use or disclosure of information contained in this page strictly prohibited
Smart Spa Remote Confidential and Proprietary Commercial Information*