



FIRE APPARATUS ACCESS ROADS

SECTION D101 GENERAL

D101.1 Scope. Fire apparatus access roads shall be in accordance with this appendix and all other applicable requirements of the *International Fire Code*.

Inspection Fee: A \$100.00 fee is required for inspection. Includes pre, post inspection and approval letter to building department.

SECTION D102 REQUIRED ACCESS

D102. Access and Loading. Facilities, buildings or portions of buildings hereafter constructed shall be accessible to fire department apparatus by way of an approved fire apparatus access road with an asphalt, concrete or other approved driving surface capable of supporting the imposed load of fire apparatus weighing at least 75,000 pounds (34,050 kg).

SECTION D103 MINIMUM SPECIFICATIONS

D103.1 Access road width with a hydrant. Where a fire hydrant is located on a fire apparatus access road, the minimum road width shall be 26 feet (7925 mm). See Figure D103.1

D103.2 Grade. Fire apparatus access roads shall not exceed 7 percent in grade.

Exception: Grades steeper than 7 percent as approved by the fire chief.

D103.3 Turning radius. The minimum turning radius shall be determined by the fire code official.

D103.4 Dead ends. Dead-ends fire apparatus access roads in excess of 150 feet (45,720 mm) shall be provided with width and turnaround provisions in accordance with Table D103.4. Subdivisions with a three lot split or more require Cul-de-sac turnaround.

TABLE D103.4 REQUIREMENTS FOR DEAD-END FIRE APPARATUS ACCESS ROADS

Length	Width (feet)	TURNAROUNDS REQUIRED	COMPACTION TEST
0-150	20	None required	None
151-750	20	120-foot Hammerhead, 60-foot "Y" or 96-foot-diameter cul-de-sac in accordance with Figure D103.1	Required
Over 750		Special approval required	Required

Private lanes that have three or more addresses shall install the Cul-de-Sac turnaround and be 24' wide

For SI: 1 foot = 304.8 mm

D103.5 Fire apparatus access road gates. Gates securing the fire apparatus access road shall comply with all of the following criteria:

1. The minimum gate width shall be 20 feet (6096 mm).
2. All locked gates must have a Knox Lock Box.

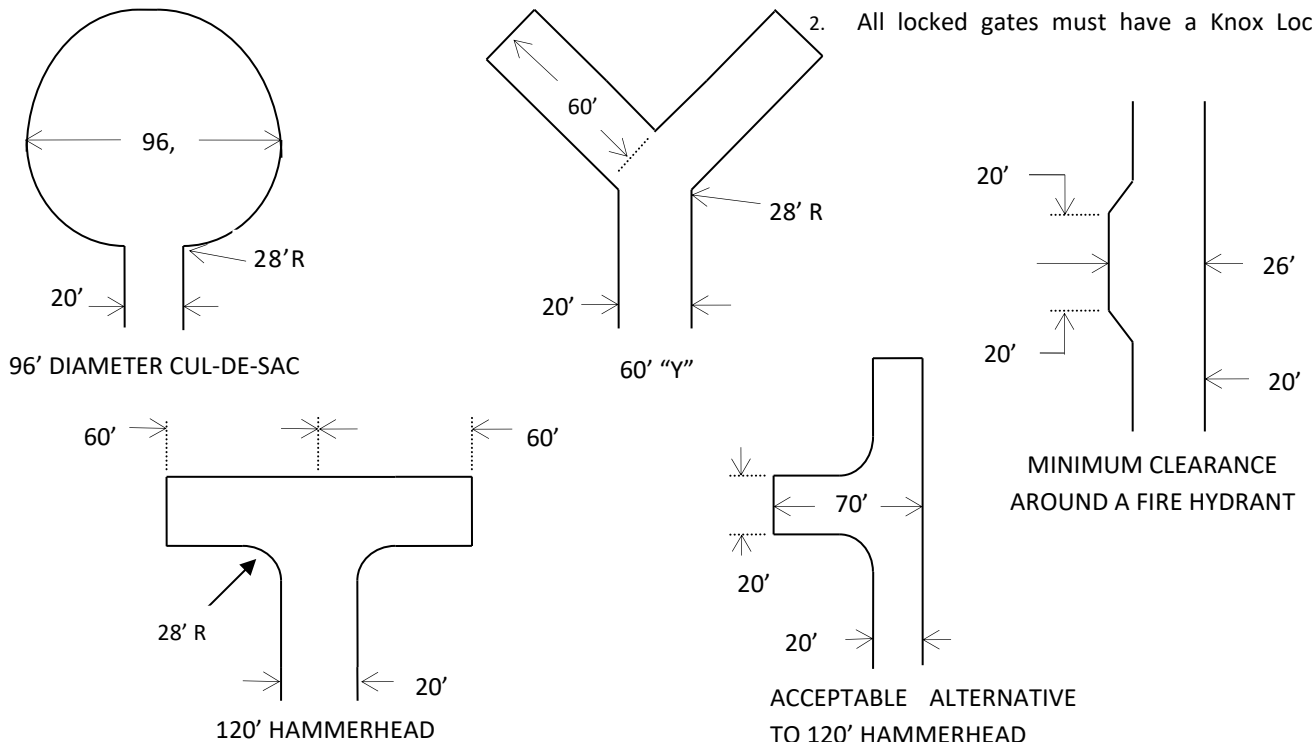

All Weather Gravel Access Road

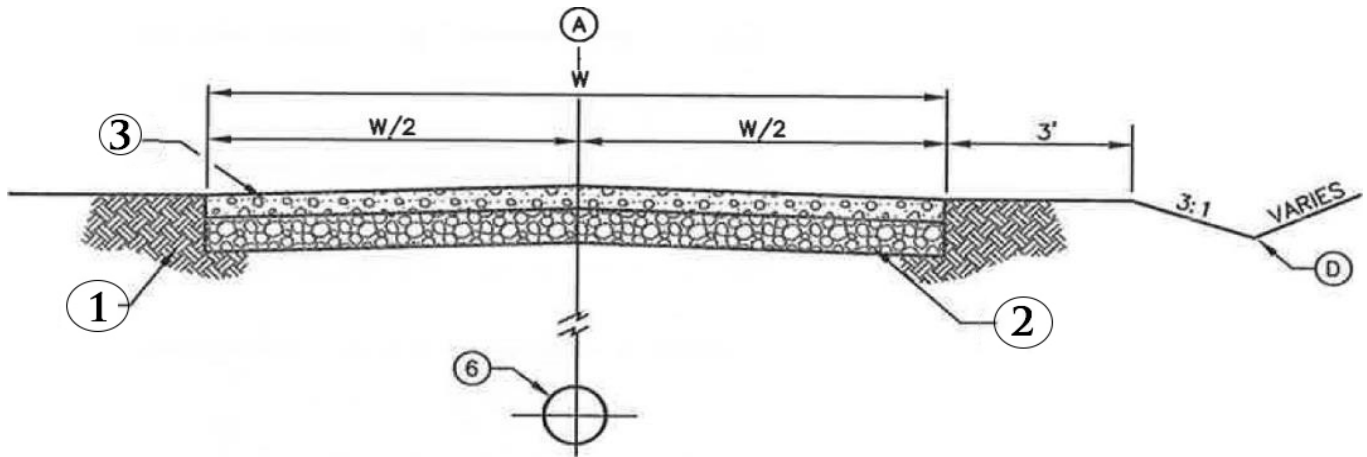

Notes:

- (A) Provide 2% crown on all road types
- (B) Roadways must be 20' min
- (C) All Roads shall be tested by a certified materials testing company to a standard of ASTM 698
- (D) Certificate of compaction must be received by the Fire District before final approval

Legend

- (1) Natural Ground
- (2) Place 12" of 6" minus Pitrun Gravel compacted to 95%
- (3) Place 4" of 3/4 road mix gravel compacted to 95%