

**SECTION - 1**  
(REF: 36/D3)

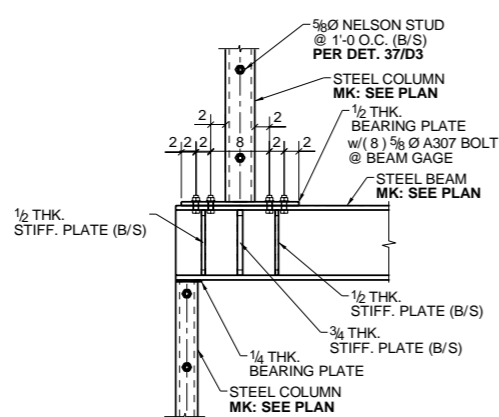

**SECTION - 2**  
(REF: 36/D3 & 80/D4)

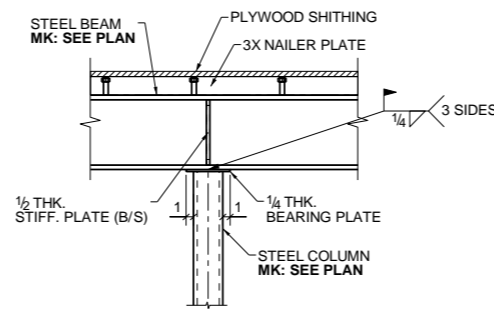

**SECTION - 3**  
(REF: 65/D4)

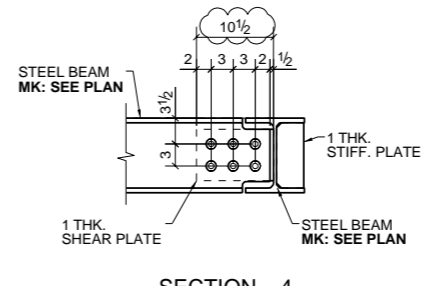

**SECTION - 4**  
(REF: 33/D3)

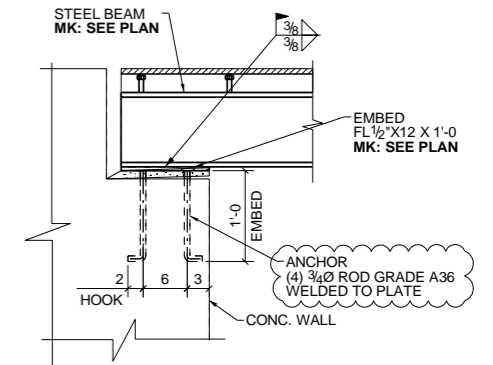

**SECTION - 5**  
(REF: 100/D5)

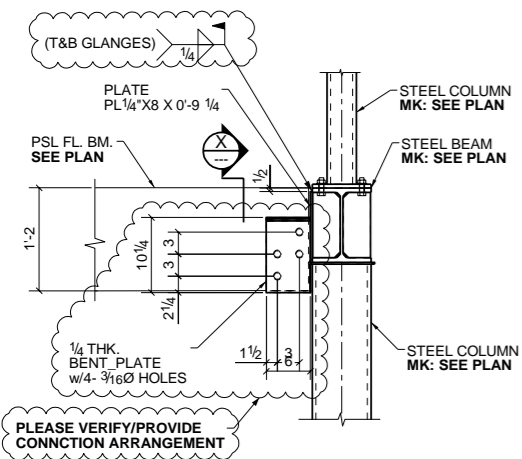

**SECTION - 6**

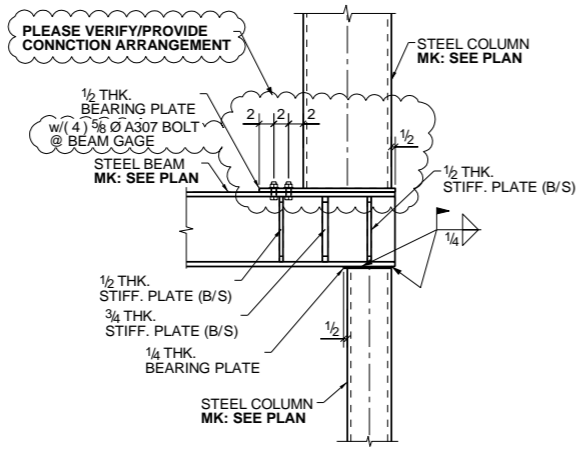

**SECTION - 7**  
(REF: 36/D3 & 80/D4)

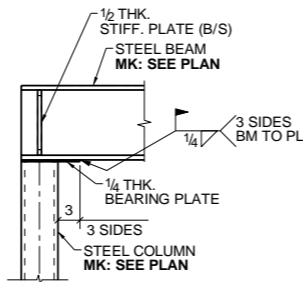

**SECTION - 8**  
(REF: 45/D3)

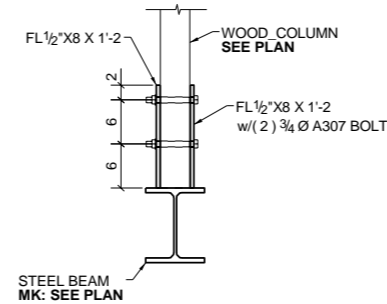

**SECTION - 9**  
(REF: 46/D3)

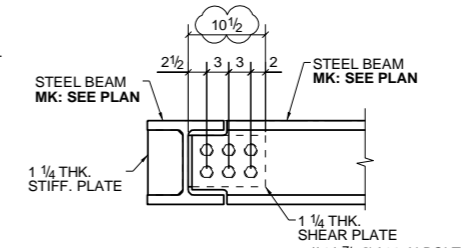

**SECTION - 10**  
(REF: 111/D5)

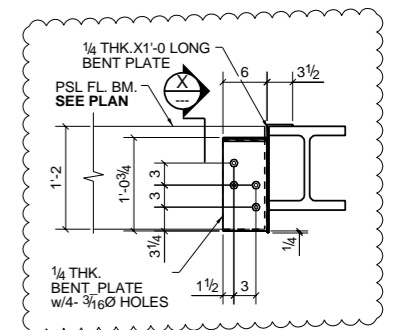

**SECTION - 11**  
(REF: 34/D3)

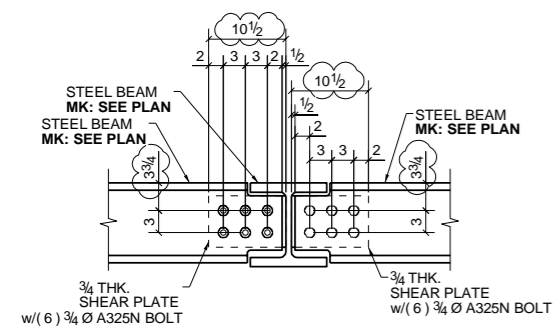

**SECTION - 12**  
(REF: 34/D3)

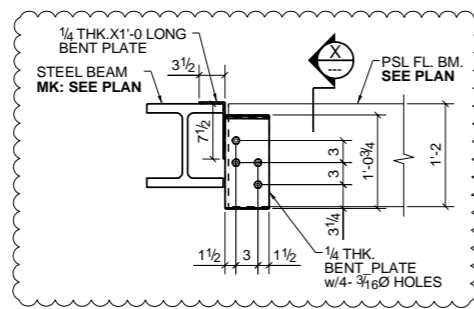

**SECTION - 13**

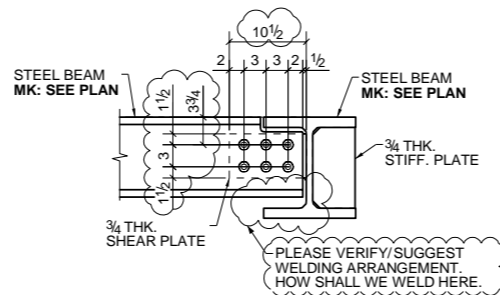

**SECTION - 15**  
(REF: 35/D3)

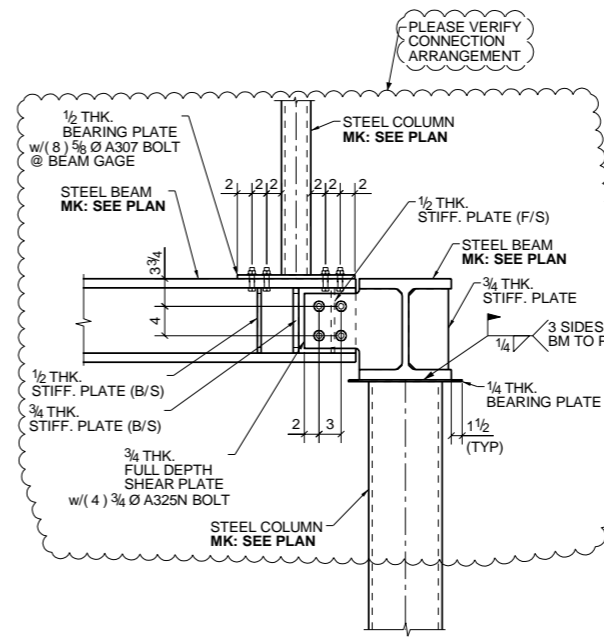

**SECTION - 16**  
(REF: 35/D3 & 80/D4 & 89/D4)

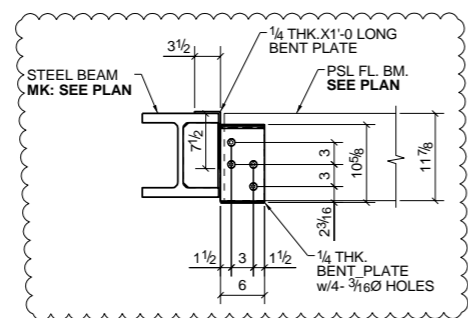

**SECTION - 14**

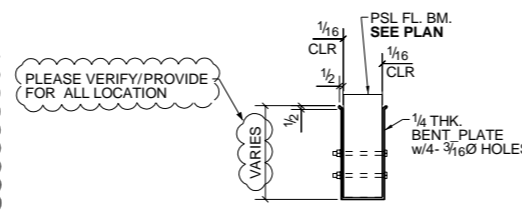

**SECTION - X**

**APPROVER NOTE:-**

ALL CLOUDED DIMENSION, INFORMATION AND ELEVATION ARE ASSUMED. PLEASE VERIFY/PROVIDE ALL DIMENSION AND ELEVATION.

DATE	NO.	REVISION/DESCRIPTION
		NOTES

ARCHITECT:- BRANDON ARCHITECT STRUCTURAL ENGG:- FMH ENGINEERING

PROJ NO:- J190053  
ELECTRODE :- E70XX  
PROJECT :- ZAHEDI RESIDENCE  
GLATEA TER. CORONA  
DETAILS OF :- ERECTION SECTION  
@ MAIN FLOOR LEVEL

DETAILER	CHECKER	FOR APPROVAL DATE: _____	FOR CONST. DATE: _____	SHEET #
				E2

Rev Info not filled