

07-Conventional Gen Sets

Off-Grid Electrical Systems in Developing Countries

Chapter 5.1-5.3, 10.10





Learning Outcomes

At the end of this lecture, you will be able to:

- ✓ describe the main components of a gen set
- ✓ compare and contrast compression ignition and spark ignition gen sets and their applications
- ✓ compute fuel consumption and identify fuel-saving strategies for operating gen sets
- ✓ analyze the operation of paralleled gen sets

Gen Sets... the big picture

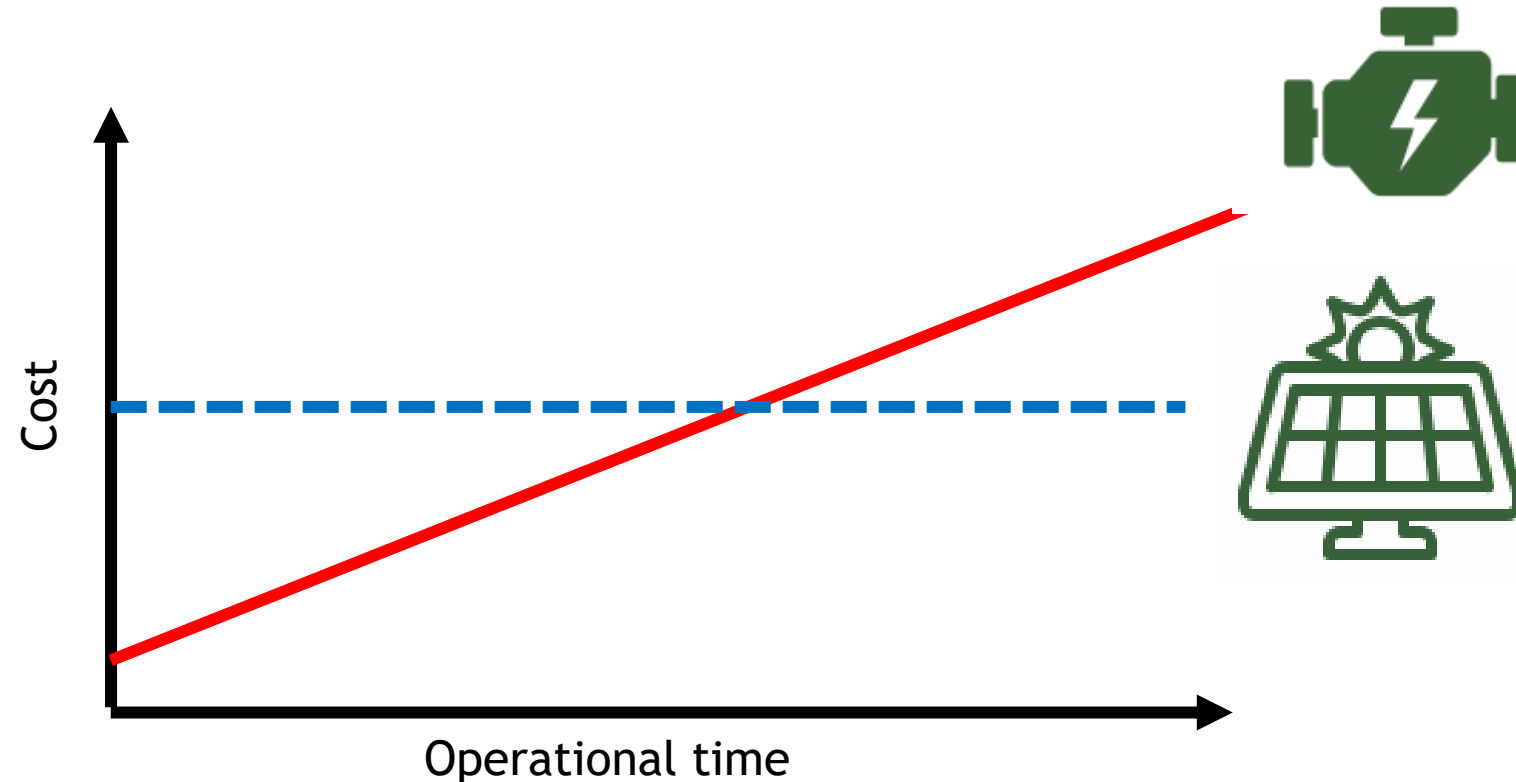

Gen sets make economic sense when the operational time is limited (for example as back-up) or when high reliability is needed

Electrical Generators

- Most Energy Conversion Systems utilize synchronous generators to produce electricity
 - Some MHP systems use self-excited induction generators
- Read Chapter 5.2 for details

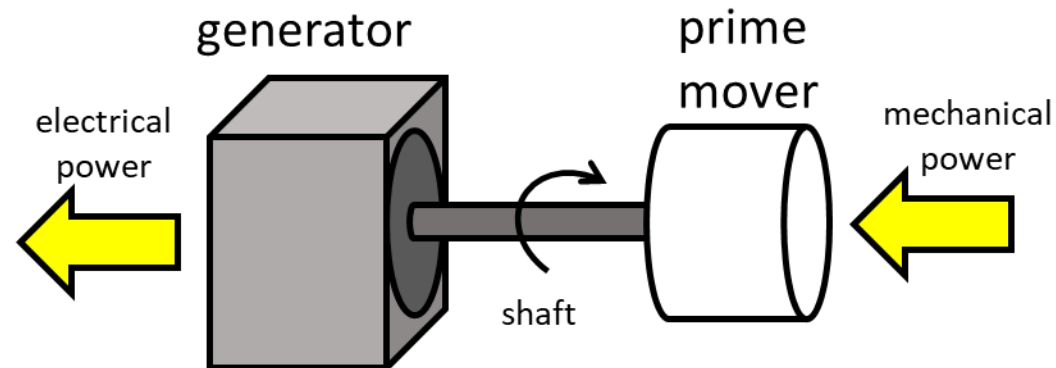

Electrical Generator Basic Concepts

1. The electrical load on the generator must be equally matched by the mechanical power provided by prime mover (assuming the generator is electrically and mechanically lossless); otherwise the rotating shaft will speed up or slow down.

This is a consequence of the law of conservation of energy.

Electrical Generator Basic Concepts

2. The frequency and magnitude of the voltage produced by a generator are proportional to:

- the rotational speed of the rotor
- the magnitude of the flux linking the coils
- the number of poles

This is a consequence of Lenz's Law

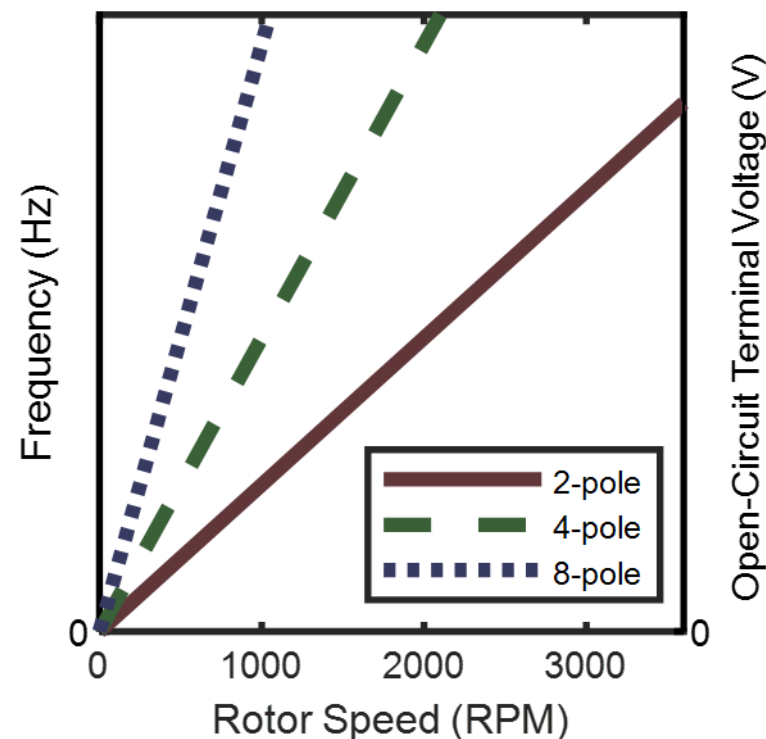

Electrical Generator Basic Concepts

3. The voltage that appears at the generator's terminals depends on the magnitude and power factor of the load.

Generator Equivalent Circuit (per-phase)

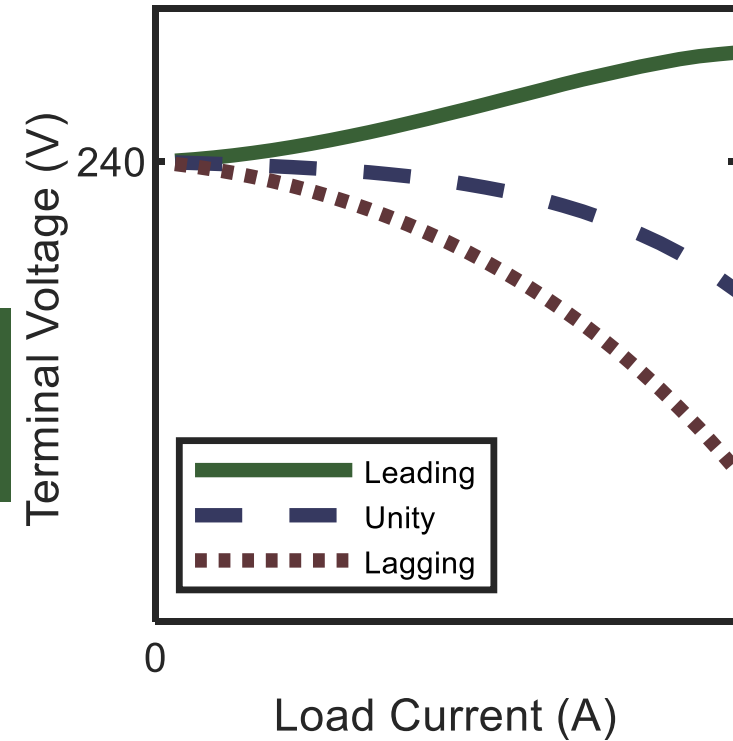
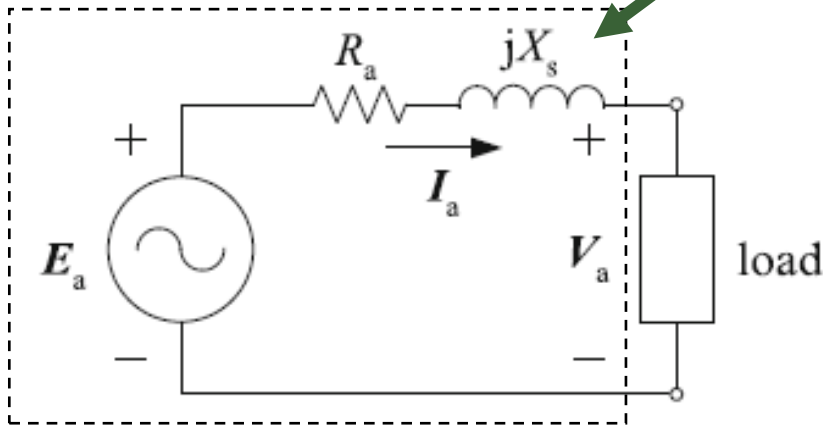

Generator Sets (Gen Sets)

- Very common off-grid energy conversion system
 - ~100 million in Nigeria
- Low capital cost, high operating cost
- Reciprocating Internal Combustion Engine (ICE) coupled to synchronous generator
- Fueled by fossil fuel or biomass (syngas or biogas)



(courtesy P. Dauenhauer)



(courtesy Sigora Haiti)

Gen Sets Components

Main components:

- Fuel tank (not shown)
- Fuel and air supply system
- Engine
- Cooling & exhaust system
- Generator & excitation system

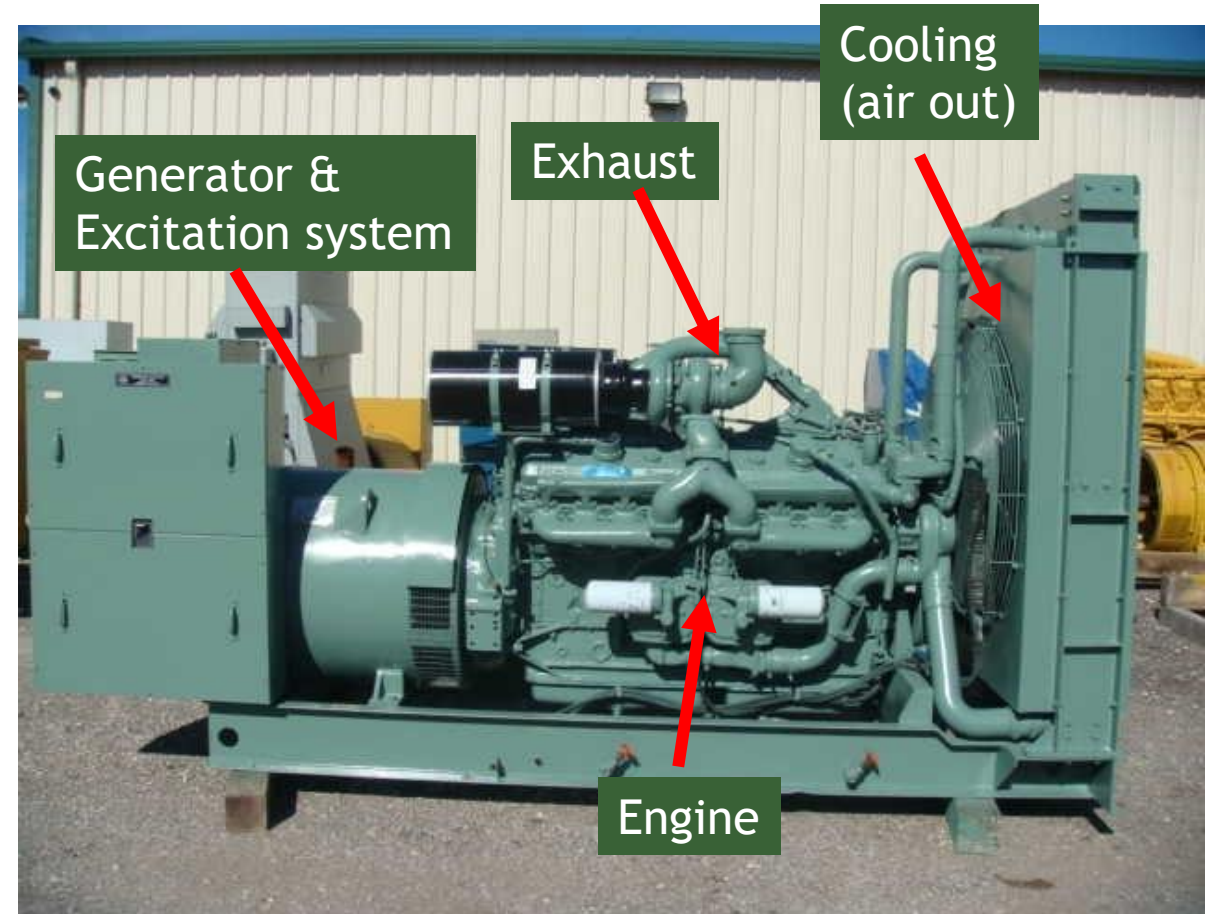

Source: <https://www.powergenenterprises.com/detroit-diesel-generator>



Gen Sets

Available in wide range
of capacities

several hundred watts to
a few megawatts



Portable Gen Set



Larger capacity gen sets are usually
pad-mounted and placed in protective
and acoustic damping enclosures

(courtesy Sigora Haiti)

Gen Set Ratings

Power output capability depends on application

Power Rating (usually kVA)

- Prime: continuous power with fluctuation (Load Factor up to 0.70)
- Standby: 500 hours per year, with variable power; usually larger than Prime rating

see ISO 8528 for additional information

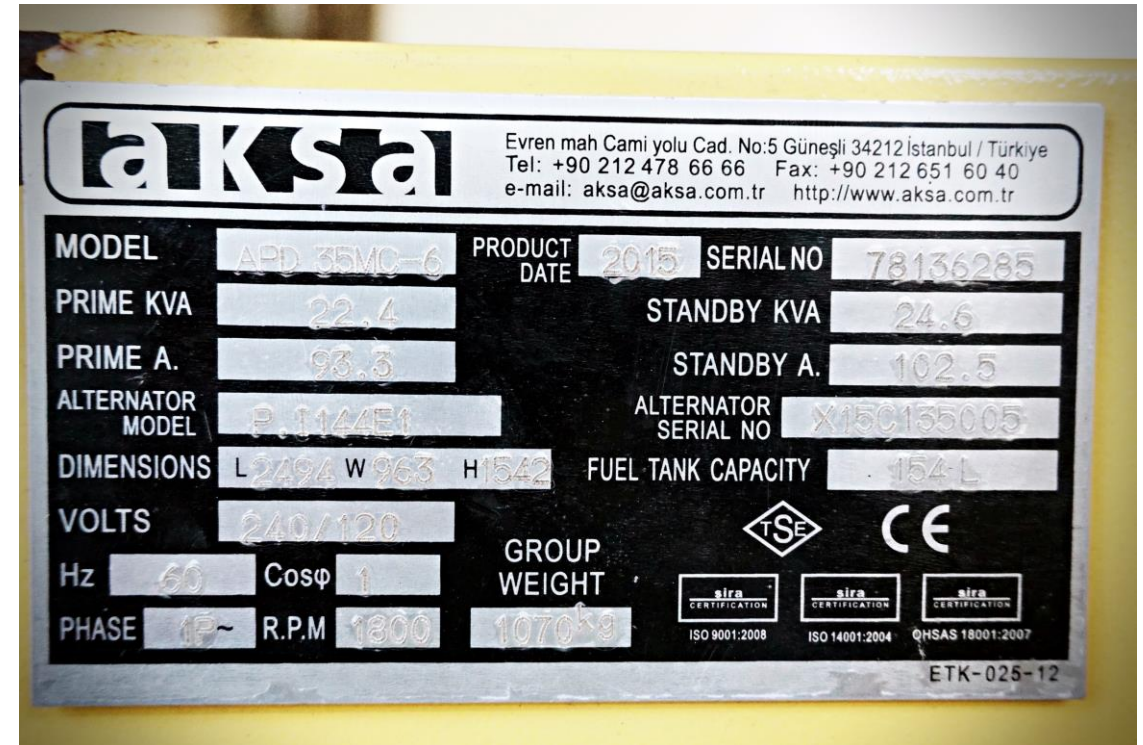

Internal Combustion Engines

- Two types: Spark Ignition (SI) and Compression Ignition (CI)
- Both rely on combustion of a fuel to drive a rotating crankshaft
- Crankshaft is connected to generator shaft, causing it to rotate

Spark Ignition Combustion Engines

Fuel is usually gasoline (petrol)

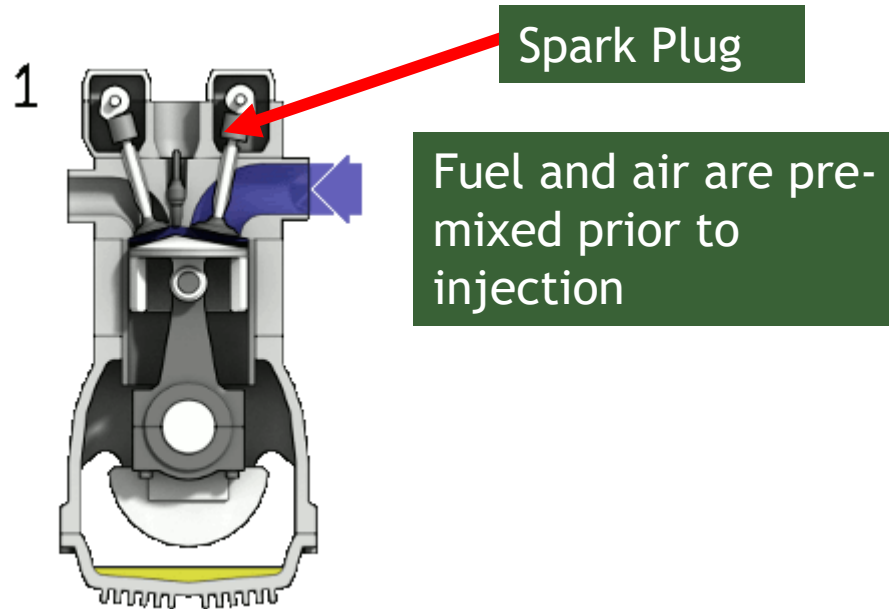

Source: Zephyris—own work, CC BY-SA 3.0

Compression Ignition Combustion Engines

Fuel is usually diesel

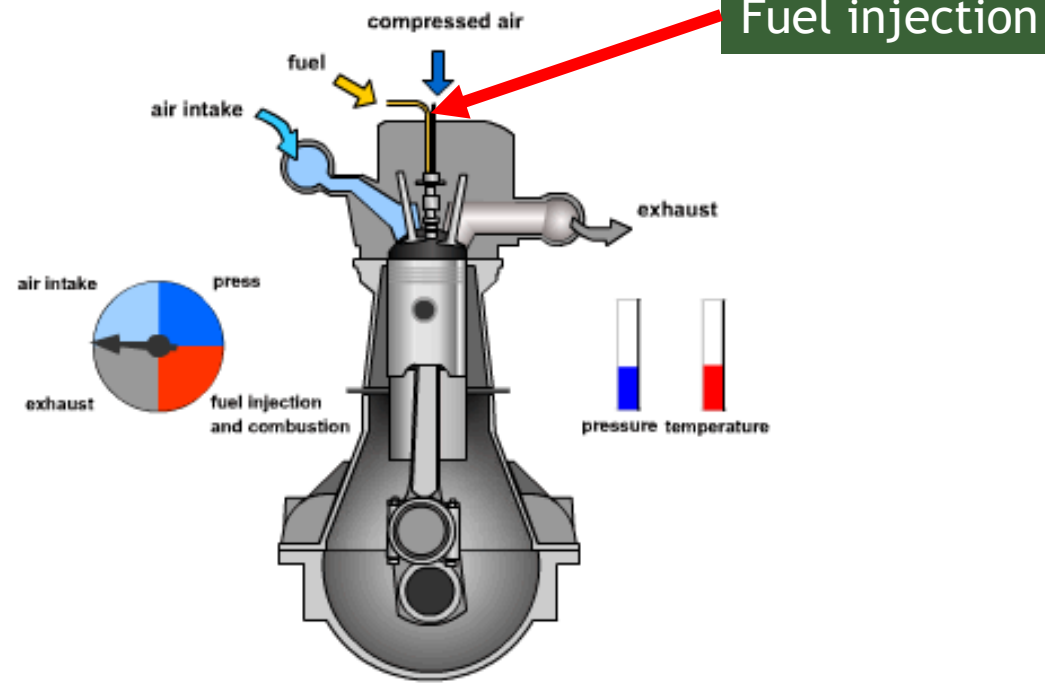

Source: <https://takemebeyondthehorizon.files.wordpress.com/2009/04/diesel21.gif?w=500>

Operational Speed

Designed operational speed of a gen set is a result of speed, torque, cost and efficiency trade-offs

- Smaller-capacity gen sets (<10 kW): usually SI coupled to two pole-generators and operate at 3600 RPM (60 Hz AC) or 3000 RPM (50 Hz AC)
- Larger-capacity gen sets: usually CI coupled to four-pole generators operating at 1800 RPM (60 Hz AC) or 1500 RPM (50 Hz AC)

Spark Ignition Versus Compression Ignition

Remember, what is true for diesel vs gasoline for vehicles is not necessarily true for gen sets

Compression Ignition offers:

- Higher reliability: 20,000 to 30,000 hours of operation before major overhaul (2-3 times longer than SI)
 - Fewer parts, lower speed operation and self-lubrication
- Decreased fuel consumption: greater efficiency (1/4 to 1/2 more efficient) from higher compression ratios; diesel has greater energy density than petrol (gasoline)
- Robustness: ruggedly built to withstand high compression ratios, less sensitive to the quality of the fuel
- Lower maintenance: lower speed operation, lower operating temperature, no spark plugs or carburetor
- Safety: diesel fuel is less flammable than gasoline

Spark Ignition Versus Compression Ignition

- Compression Ignition engines are heavier, louder, vibrate more, are more expensive (up front), and emit more un-combusted hydrocarbons
- Diesel fuel can “gel” at low temperatures, but degrades slower than gasoline
- Diesel fuel might be less available and more expensive than gasoline

Gen Set Selection

	Spark Ignition (gasoline)	Compression Ignition (diesel)
Back-Up Application	✓	
Continuous Use Application		✓
Fuel Storage (volume, safety)		✓
Lifespan		✓
Noise	✓	
Physical Size (smaller)	✓	
Portability	✓	
Safety (of fuel)		✓

These are general
characteristics only

Frequency Regulation of Gen Sets

- Gen Sets are designed to operate at a (nearly) constant speed so that the frequency of the AC voltage is (nearly) constant
 - Some generators have a “droop”—frequency somewhat decreases with load
- Governor increases mechanical power to crankshaft if speed decreases, and decreases power if speed increases
 - SI: adjust amount of air-fuel mixture (throttling)
 - CI: adjust amount of injected fuel (fuel metering)

Excitation

- Recall that terminal voltage (AC bus) should be regulated
 - Automatic Voltage Regulators (AVR)
- Low quality gen sets may not have an AVR and thus have poor voltage regulation
- Larger capacity/higher quality: brushless or static exciters and external batteries
- Smaller capacity: rely on residual magnetism on start-up and may require “field flashing” if gen set has been idle for prolonged period

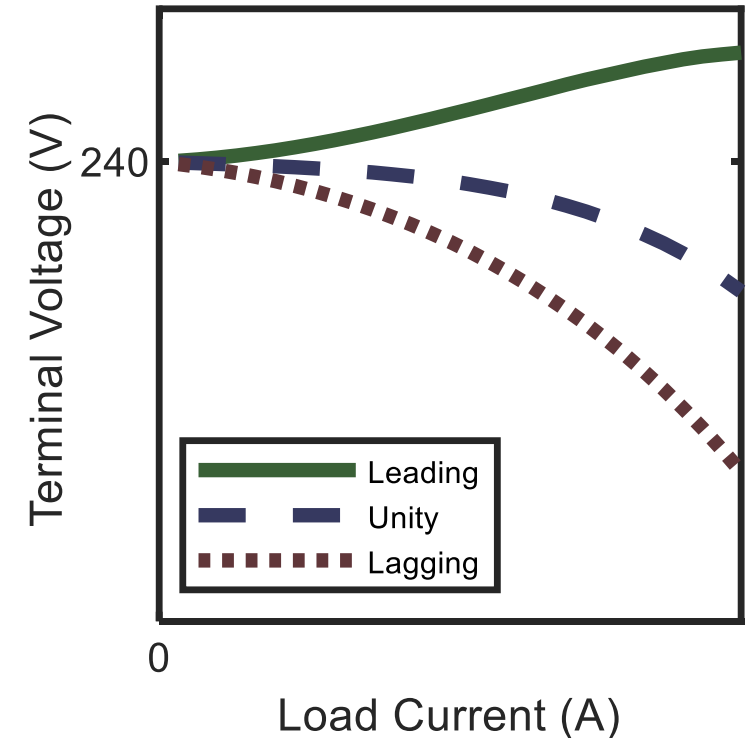

Fuel Consumption

- Fuel costs for gen sets are high
- Prices can fluctuate and consistent supply is not guaranteed
- Energy density
 - Diesel: ~37 to 39 MJ/l
 - Gasoline: ~31 to 36 MJ/l

Country	Diesel Price (\$/liter)
Angola	0.43
Botswana	0.86
India	0.97
S. Africa	1.06
Mali	1.09
Burundi	1.29
Zambia	1.43
Zimbabwe	3.19

Source: https://www.globalpetrolprices.com/diesel_prices/

Engine Losses

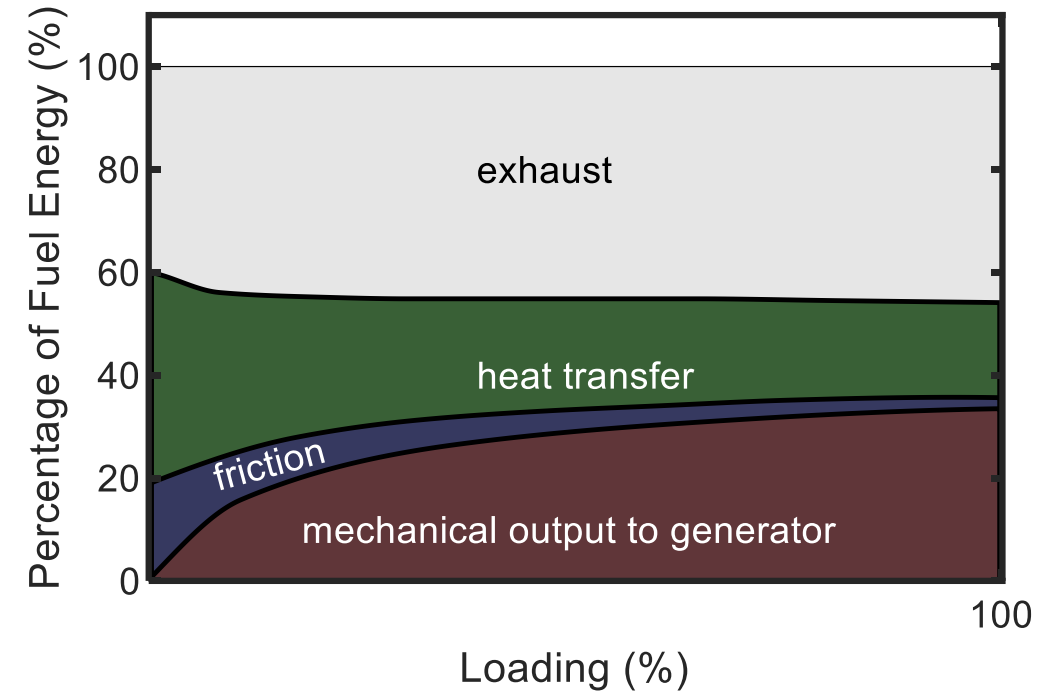

- Friction: from pistons, bearings, valve train, pumps other moving parts
- Heat transfer: heat from combustion that is rejected to the cooling system
- Exhaust: heat in the gases that are emitted from the engine



Efficiency increases with loading

Gen Set Efficiency

Gen Set Efficiency = ICE Efficiency \times Generator Efficiency



$$\eta_{\text{genset}}(P_e) = \eta_{\text{ICE}}(P_e) \times \eta_{\text{gen}}(P_e)$$

Gen Set Efficiency depends on electrical power output (P_e)

Gen Set Efficiency

- Gen set efficiency increases with loading and capacity (rated power)
- Loading: percent of gen set's rated power being produced by the gen set
- Maximum efficiency usually between 20% and 40%

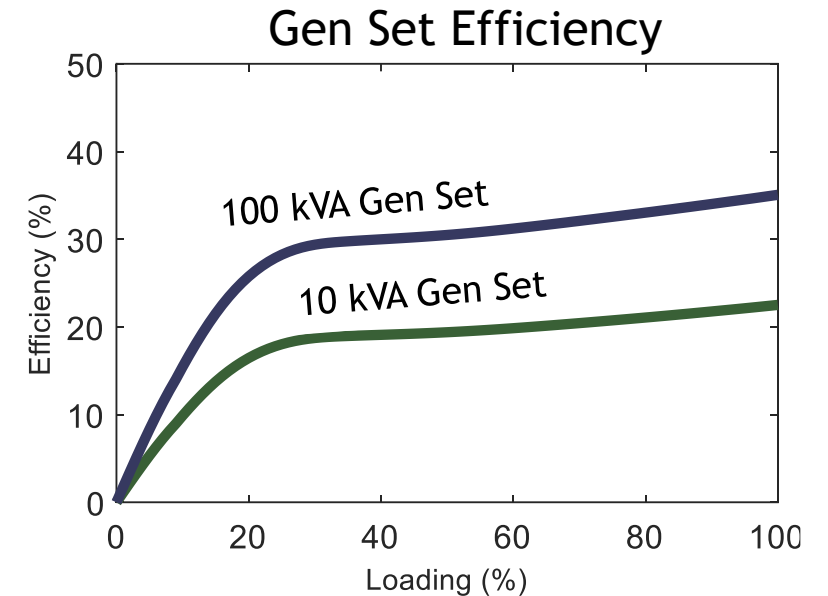

Fuel Consumption

Capacity (kW)	Loading			
	25% (l/hr)	50% (l/hr)	75% (l/hr)	100% (l/hr)
10	1.3	2.5	3.5	4.3
50	4.9	8.7	12.5	16.4
100	8.3	15.9	22.3	27.6
500	39.7	73.8	89.7	118.1

Exercise

Compute the efficiency of the 10 kW gen set if loaded at 50%. Assume the energy density of diesel fuel is 39 MJ/liter

Capacity (kW)	25% (l/hr)	50% (l/hr)	75% (l/hr)	100% (l/hr)
10	1.3	2.5	3.5	4.3
50	4.9	8.7	12.5	16.4
100	8.3	15.9	22.3	27.6
500	39.7	73.8	89.7	118.1

Which is a more efficient strategy to supply 100 kWh of energy?

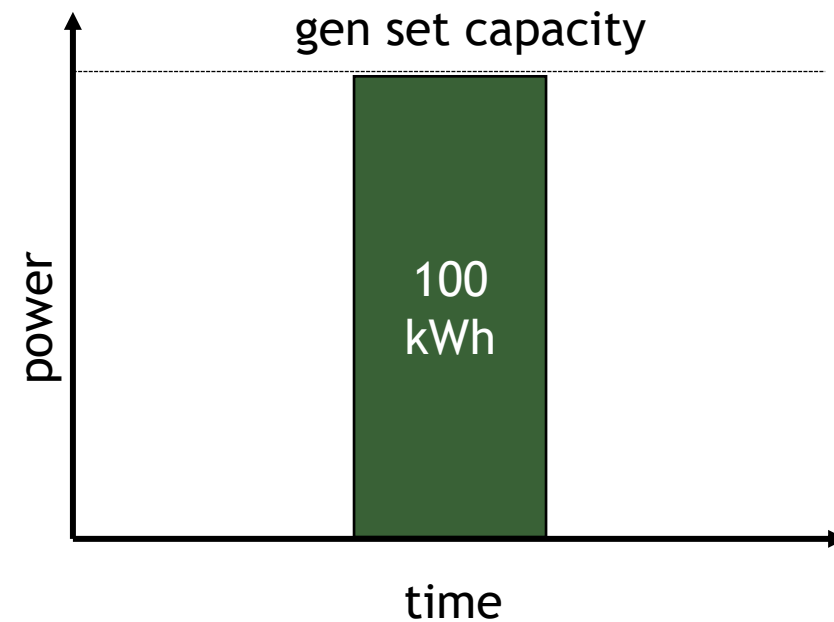
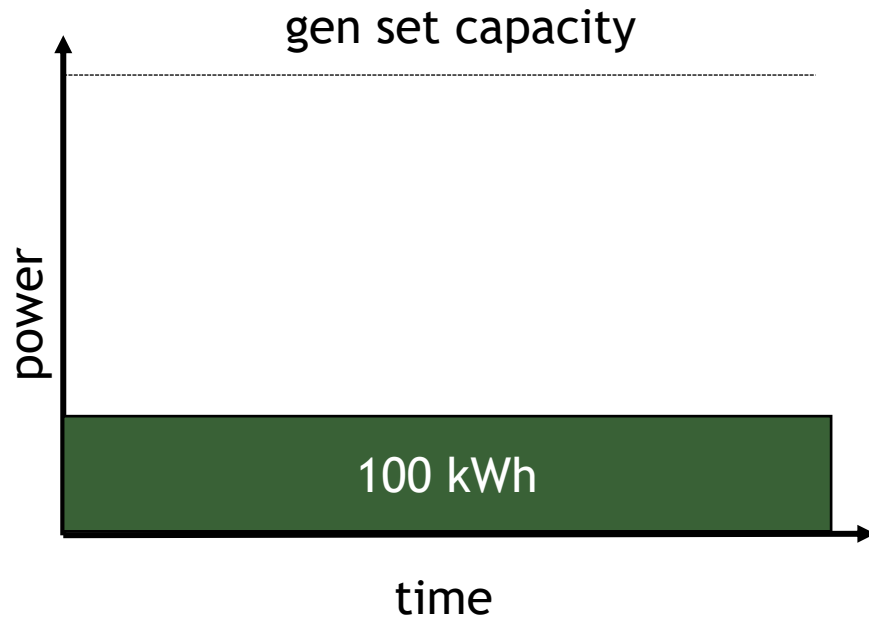

Wet Stacking

- When diesel gen sets operate at low loading some of the fuel is not combusted
- Oily substance can accumulate in the exhaust system and cause engine failure
- Avoid operating diesel gen sets at below 30 to 50% for prolonged periods of time



Source: D. Maalouf, Edarat Group



Design Example: Mwase

Load Estimation & Characterization

- Survey method used to produce load profile
 - Individual loads are aggregated into single load profile
 - Assumed weekday is the same as weekend
- Load growth estimate: 5% per year

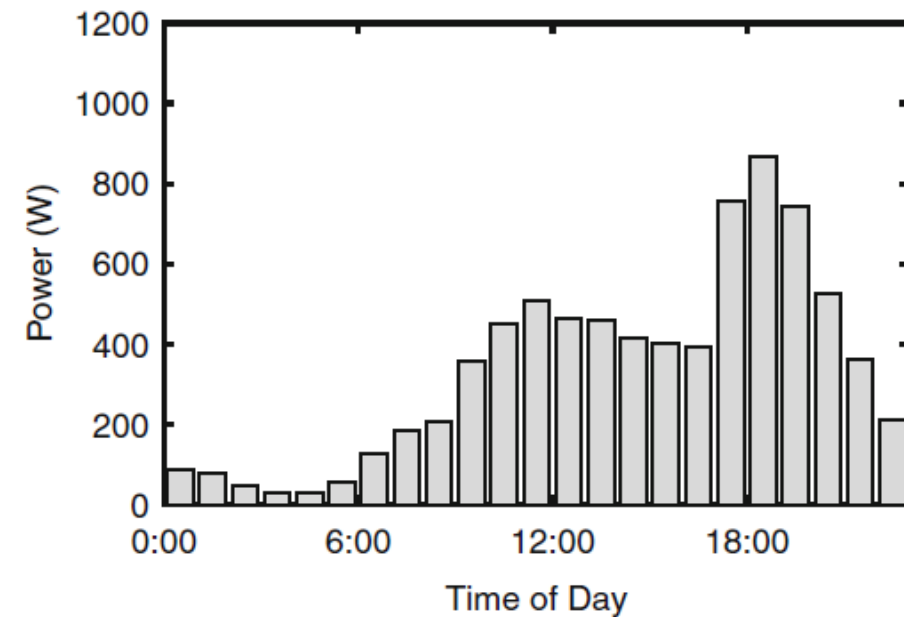

Parameter	Initial	After five years
Avg. daily load (kWh/day)	7.875	10.05
Peak individual load (kW)	4.11	5.24
Coincidence factor	0.37	0.37
Peak aggregate load (kW)	1.52	1.94
Power factor	0.85	0.85

Exercise

Estimate the daily and annual cost of supplying the village of Mwase. Assume a 5 kW diesel gen set is used whose average consumption is 0.7 liters per hour. The cost of diesel fuel is US\$1.4/liter.

Gen Set Control

- Gen sets can be operated using different strategies in hybrid systems
 - See Chapter 10.9 (not required reading)

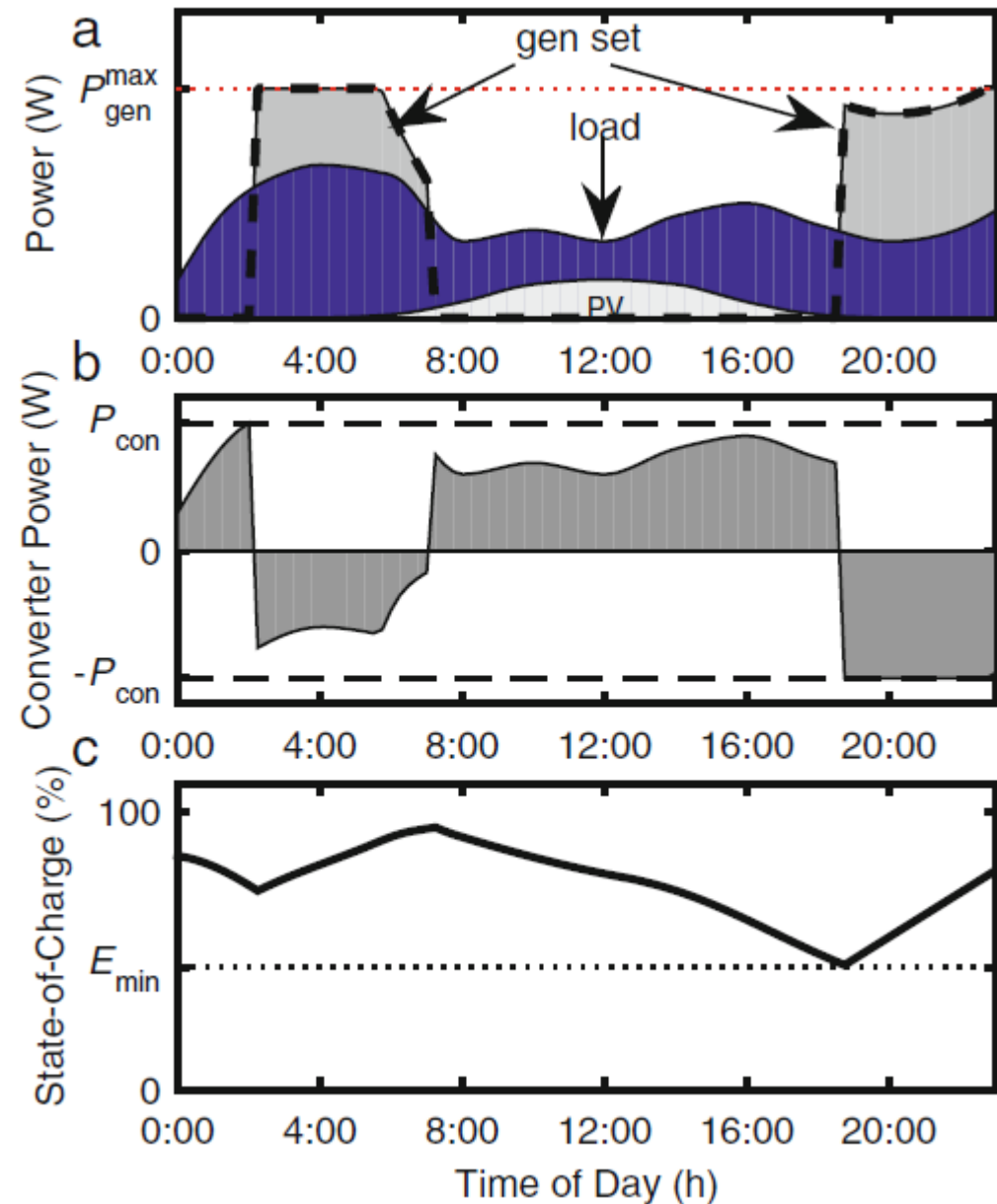

Paralleling

- Gen Sets can be connected to the same AC Bus (“paralleling”)
- More common in larger off-grid systems (>100 kW) and those with higher reliability requirements

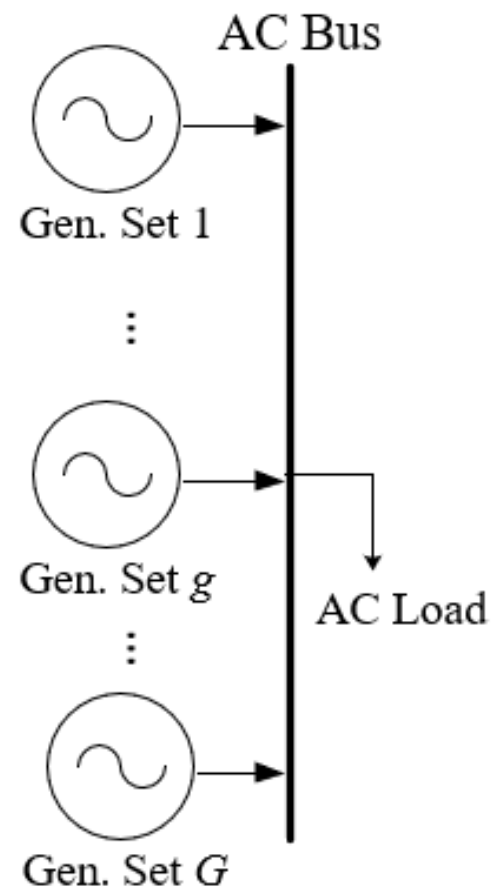

Paralleling

Reasons for paralleling gen sets:

- Reliability—paralleling adds redundancy to the system so that if one gen set fails, a portion of or even the entire load can be served
- Scalability—gen sets can be added or removed from the mini-grid as needed
- Serviceability—maintenance can be done on one gen set at a time while the other(s) continue to serve the load

Paralleling Considerations

The generators should have:

1. the same number of phases
2. the same phase rotation
3. have the same open-circuit terminal voltage at a given speed
4. each have voltage and speed control, for example, through an AVR and a governor

Consider using the same model generator by the same manufacturer

Parallel Operation

- Care must be taken to ensure that paralleled generators are operated to have the same (or nearly the same) voltage, frequency, magnitude, and phase
- Manual synchronization is possible, but external controllers can be used

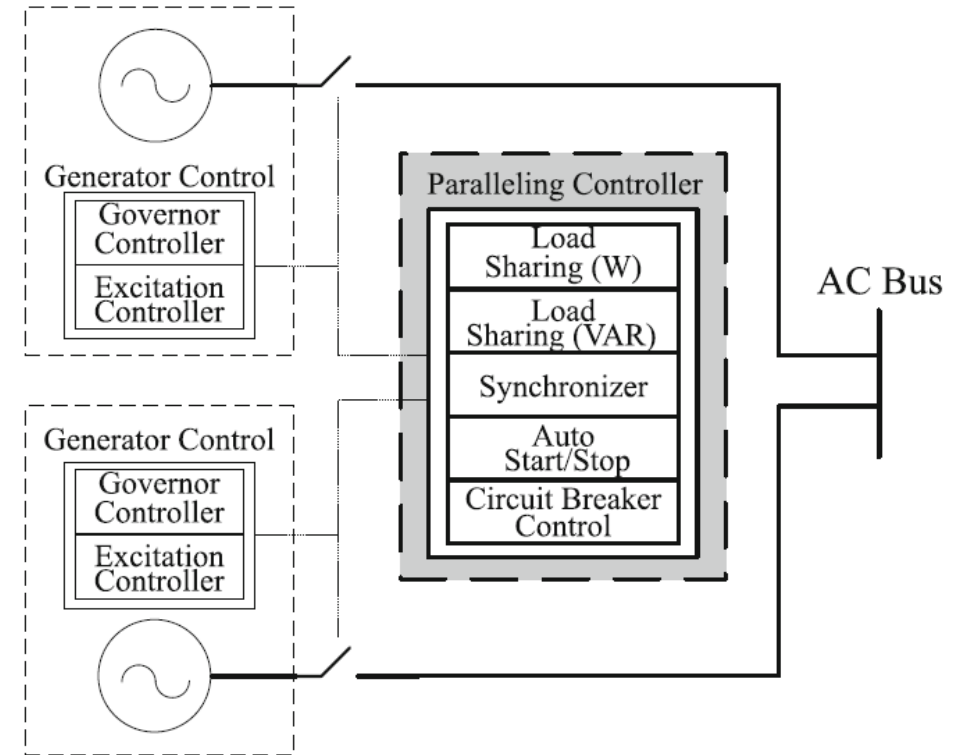

Load Sharing

- Ignoring losses the power to the load P_L is related to the power from each gen set as:

$$P_L = P_{\text{gen},1} + \dots + P_{\text{gen},g} + \dots + P_{\text{gen},G}$$

- If the load is shared equally, then

$$P_{\text{gen},1} = \dots = P_{\text{gen},G} = \frac{P_L}{G}$$

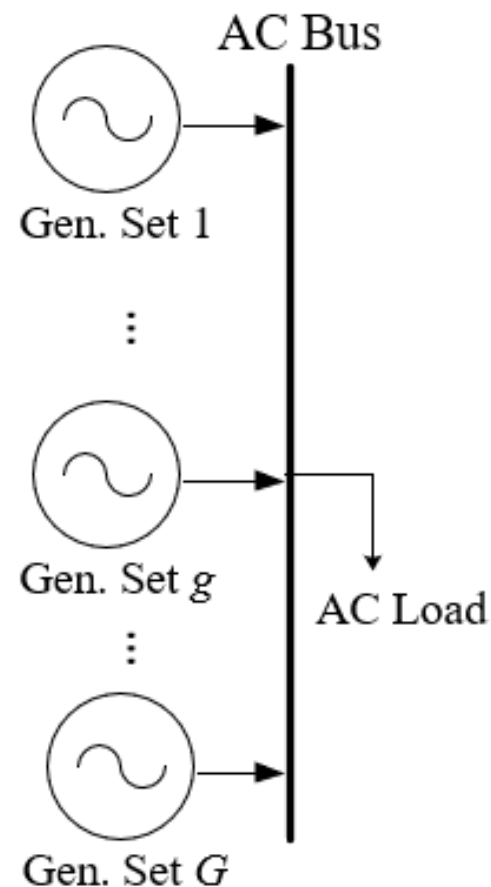

Load Sharing

- Equal load sharing is not always desirable
- If gen sets have different capacities, then consider sharing based on rated capacity

$$P_{\text{gen},g} = P_L \times \frac{P_{\text{rated},g}}{\sum_{k=1}^G P_{\text{rated},k}}$$

Load Sharing Approaches

- Isochronous: centralized control so that frequency is constant
 - External controller/communication is required for multiple gen sets
 - Available on higher-end gen sets
- Droop: de-centralized control method (no gen set communication needed); frequency somewhat decreases as load increases (gen set slows down)
 - provides a stable operating point

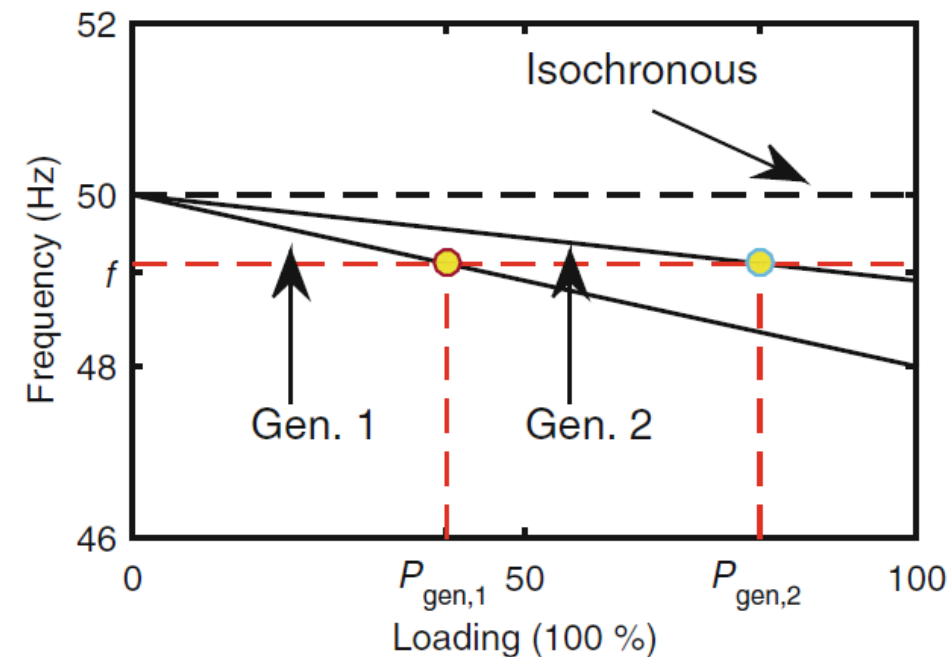

Droop

- Frequency that generator g operates at is determined by

$$f_g = f_{g,0} - d_g \frac{P_g}{P_{\text{rated},g}}$$

f_g : operating frequency (Hz)

$f_{g,0}$: no-load operating frequency (Hz)

d_g : droop slope (Hz/%)

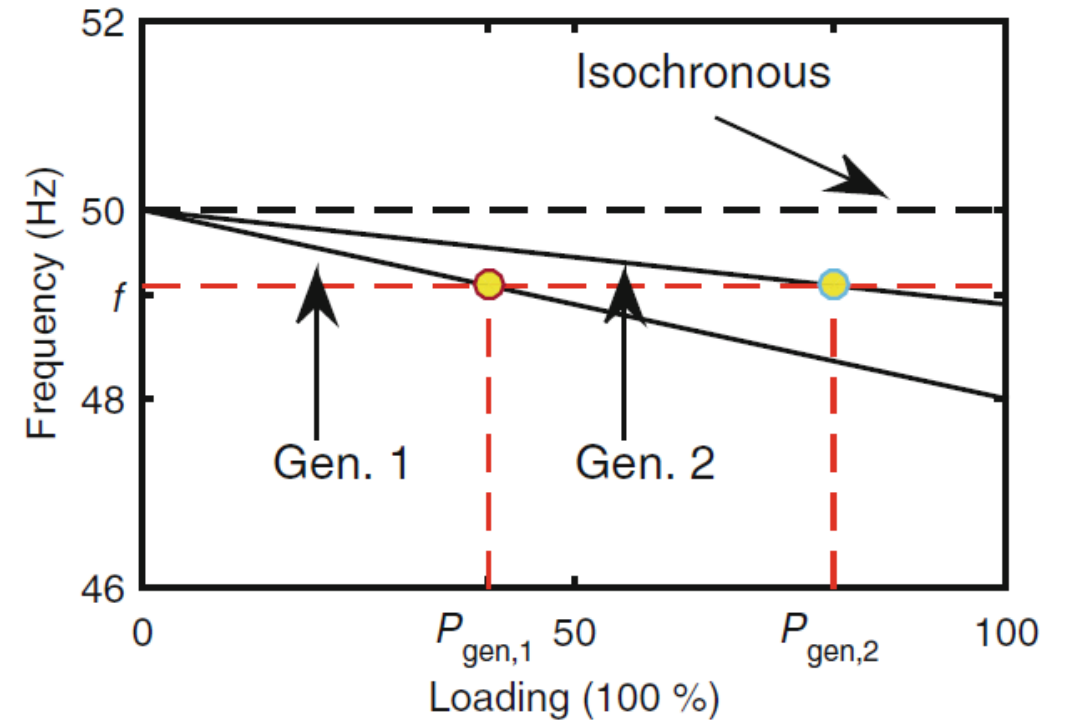

Example

Consider a mini-grid with two gen sets operated in parallel. Gen set 1 is rated at 75 kW with droop slope of 0.6, and Gen set 2 is rated at 37.5 kW with a droop slope of 0.3. Both have a no-load frequency of 50 Hz. Determine the operating frequency and the power output by each gen set if the load increases to 60 kW.

Example

Consider a mini-grid with two gen sets operated in parallel. Gen set 1 is rated at 75 kW with droop slope of 0.6, and Gen set 2 is rated at 37.5 kW with a droop slope of 0.3. Both have a no-load frequency of 50 Hz. Determine the operating frequency and the power output by each gen set if the load increases to 60 kW.

Substitute the known values:

$$f_1 = f_{1,0} - d_1 \frac{P_1}{P_{\text{rated},1}} = 50 - 0.6 \frac{P_1}{75}$$

$$f_2 = f_{2,0} - d_2 \frac{P_2}{P_{\text{rated},2}} = 50 - 0.3 \frac{P_2}{37.5}$$

Two equations, four unknowns.
What other equations are relevant?

Example

Consider a mini-grid with two gen sets operated in parallel. Gen set 1 is rated at 75 kW with droop slope of 0.6, and Gen set 2 is rated at 37.5 kW with a droop slope of 0.3. Both have a no-load frequency of 50 Hz. Determine the operating frequency and the power output by each gen set if the load increases to 60 kW.

$$f_1 = f_2$$

$$60 = P_1 + P_2$$

Each generator must operate at the same frequency.
Conservation of power

Example

Consider a mini-grid with two gen sets operated in parallel. Gen set 1 is rated at 75 kW with droop slope of 0.6, and Gen set 2 is rated at 37.5 kW with a droop slope of 0.3. Both have a no-load frequency of 50 Hz. Determine the operating frequency and the power output by each gen set if the load increases to 60 kW.

$$f_1 = f_2$$

$$50 - 0.6 \frac{P_1}{75} = 50 - 0.3 \frac{P_2}{37.5}$$

$$P_1 = \frac{75}{0.6} \times 0.3 \frac{P_2}{37.5}$$

$$P_1 = P_2$$

The power is evenly shared, and so apply the conservation of power, each gen set supplies 30 kW

Example

Consider a mini-grid with two gen sets operated in parallel. Gen set 1 is rated at 75 kW with droop slope of 0.6, and Gen set 2 is rated at 37.5 kW with a droop slope of 0.3. Both have a no-load frequency of 50 Hz. Determine the operating frequency and the power output by each gen set if the load increases to 60 kW.

$$f_1 = f_2 = 50 - 0.6 \frac{30}{75} = 49.76 \text{ Hz}$$

Gen sets



- Available in wide range of capacities (hundreds of watts to megawatts)
- Low capital cost (US\$100-US\$800/kW)
- Possible for on-site repair and maintenance
- On-demand power with little start-up time (useful in high-reliability or high-peak applications)
- Can be portable
- Easy operation: automatic voltage, frequency control



- High fuel cost
- Fuel supply chain must be managed
- Fuel must be stored
- Air and noise pollution
- Regular maintenance and repair
- Relatively short lifespan (20,000-30,000 operational hours)

Contact Information

Henry Louie, PhD

Professor

Seattle University

 @henrylouie

hlouie@ieee.org

Office: +1-206-398-4619