



15-Battery Capacity

Off-Grid Electrical Systems in Developing Countries

Chapter 8.5.3–8.5.7



Learning Outcomes

At the end of this lecture, you will be able to:

- ✓ define and understand charge and energy capacity of batteries
- ✓ interpret information provided on battery specification sheets, including C-rate, hour-rate, capacity tables/curves, and cycle life
- ✓ apply Peukert's equation to estimate battery charge capacity

Battery Capacity

- Battery Capacity: indication of how long a battery can meaningfully supply a constant current load
- “Battery Capacity” can refer to either:
 - Charge capacity, measured in amphotours (Ah) (more common)
 - OR
 - Energy capacity, measured in kilowatthours (kWh) (less common)

Charge Capacity

- Charge capacity (simple definition): quantity of electric charge (coulombs) that can be supplied to an external load
- Usually expressed in amphotours rather than coulombs

1 Ampere = 1 coulomb/second

1 Ampere-second = 1 coulomb

1 Amperehour = 3600 coulomb

Charge Capacity

- The maximum amount of charge that a battery can provide is limited by the mass of its active materials (see Example 8.1)
- More massive (larger) batteries can supply more charge than smaller batteries
- Once active materials have been depleted (or no longer able to be involved in the discharge reaction for whatever reason), the battery can no longer supply charge. Examples:
 - All lead or lead dioxide is converted to lead sulfate
 - Sulfation has prevented remaining lead or lead dioxide to react with the electrolyte

Computing Charge (Discharge)

The charge provided by the battery is found from:

$$\text{charge} = \int_0^T i_B(t) dt$$

$i_B(t)$: battery discharge current, (A)
charge: battery discharge, (C)
 T : time discharge ends (usually in hours or minutes)

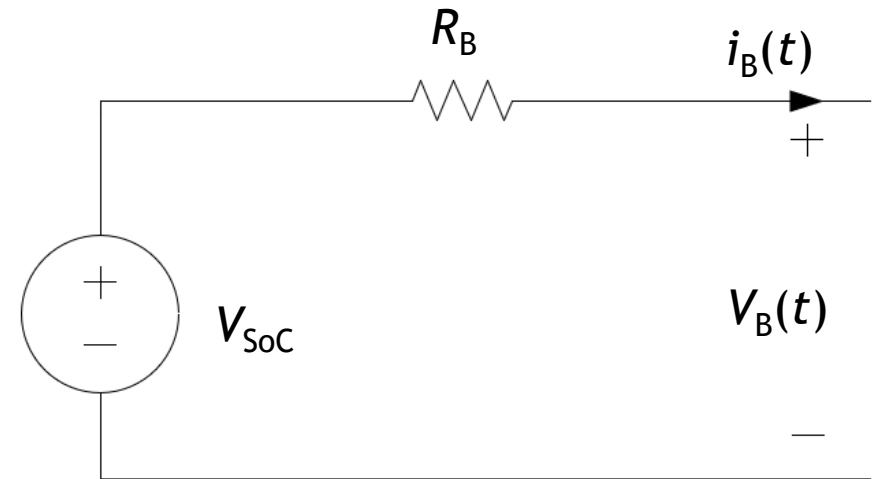

Constant Current Discharge

- We are particularly interested in the case where the discharge current is constant
- If the current is constant:

$$\text{charge} = \int_0^T i_B(t) dt = \int_0^T I_B dt = TI_B$$

We generally use uppercase values to designate DC variables

Constant Current Discharge

- We express the charge as the variable $charge_x$, where the “x” is the constant discharge current:

$$charge_x = xT_{d,x}$$

$T_{d,x}$ is the duration, in hours, the battery was discharged at a constant current x

- We will usually express charge in amphours (instead of, say, ampminutes)

Constant Current Discharge

Consider batteries discharged under the following scenarios (where the discharge current and times are arbitrary):

Constant current of 10 A for 30 hours

$$\text{charge}_{10} = xT_{d,x} = 10 \times 30 = 300 \text{ Ah}$$

Constant current of 60 A for 20 hours

$$\text{charge}_{60} = xT_{d,x} = 60 \times 20 = 1200 \text{ Ah}$$

We will see that it is important to always reference the current that the battery was discharged at

Exercise

Compute the charge provided by the battery, in Amphours, if the discharge current is:

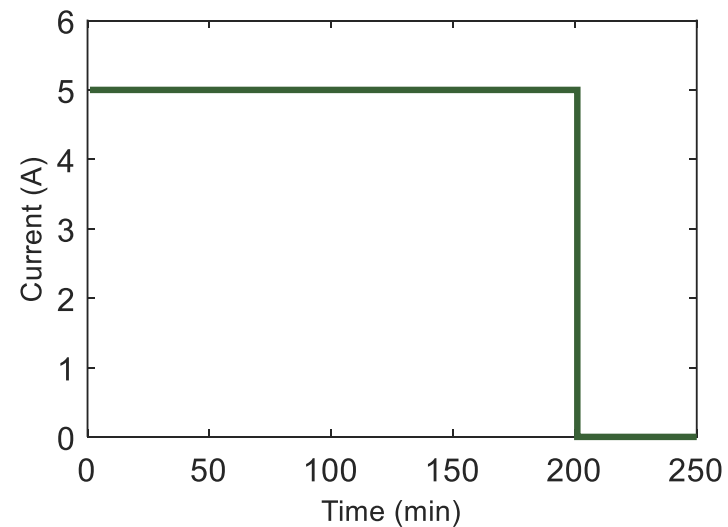

Exercise

Compute the charge provided by the battery, in Amphours, if the discharge current is:

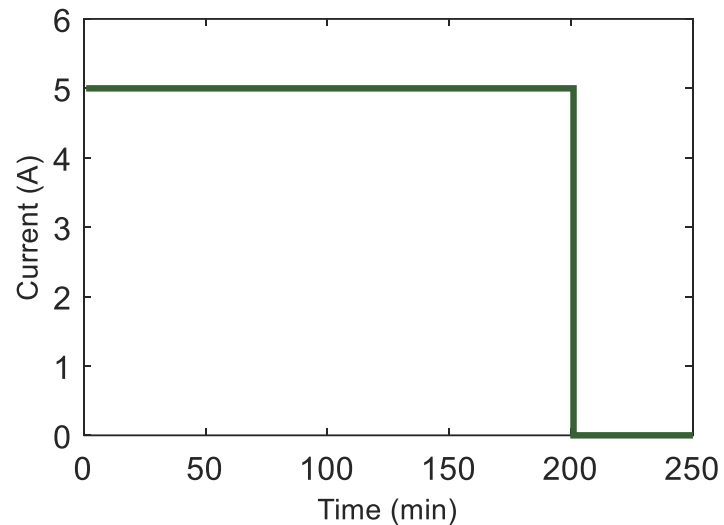

$$\text{charge}_5 = xT_{d,x} = 5 \times \frac{200}{60} = 16.67 \text{ Ah}$$

Capacity: a more specific definition

- Battery Capacity: charge that a battery can supply at a particular, constant, current before its voltage drops before a manufacturer-defined cut-off voltage (e.g. 1.75 V/cell)
 - battery is capable of supplying additional charge, but at a lower voltage and possibly damaging the battery (until the active material is entirely depleted)
- Empirically determined by manufacturer

Charge Capacity Notation

The *charge capacity* is expressed as:

$$c_x = xT_{d,x}$$

$T_{d,x}$ is the duration, in hours, the battery was discharged at a constant current x until the cut-off voltage was reached

Example: the charge capacity of a battery that is discharged at 10A for 12 hours before the cut-off voltage is reached is

$$c_{10} = 10 \times 12 = 120 \text{ Ah}$$

Measuring Battery Charge Capacity

- Connect battery to variable resistor and measure voltage and current
- Adjust the resistance so that the current is constant ($I_B = 8A$)
- Keep adjusting the resistance as the battery terminal voltage decreases

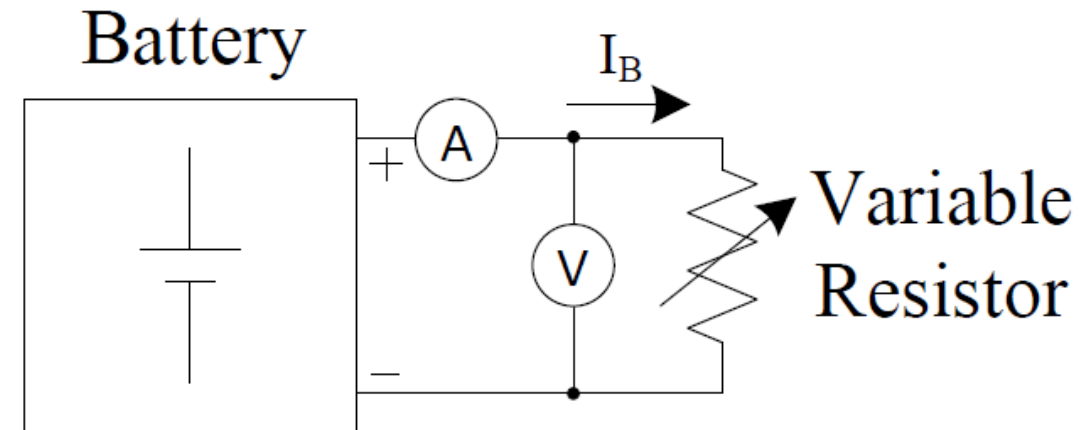

Cut-Off Voltage

In this example, the battery reaches cut-off voltage of

6 cells x 1.8V/cell = 10.8V at 19 h

Capacity of the battery when discharged at 5A is 5A x 19 h = 95 Ah

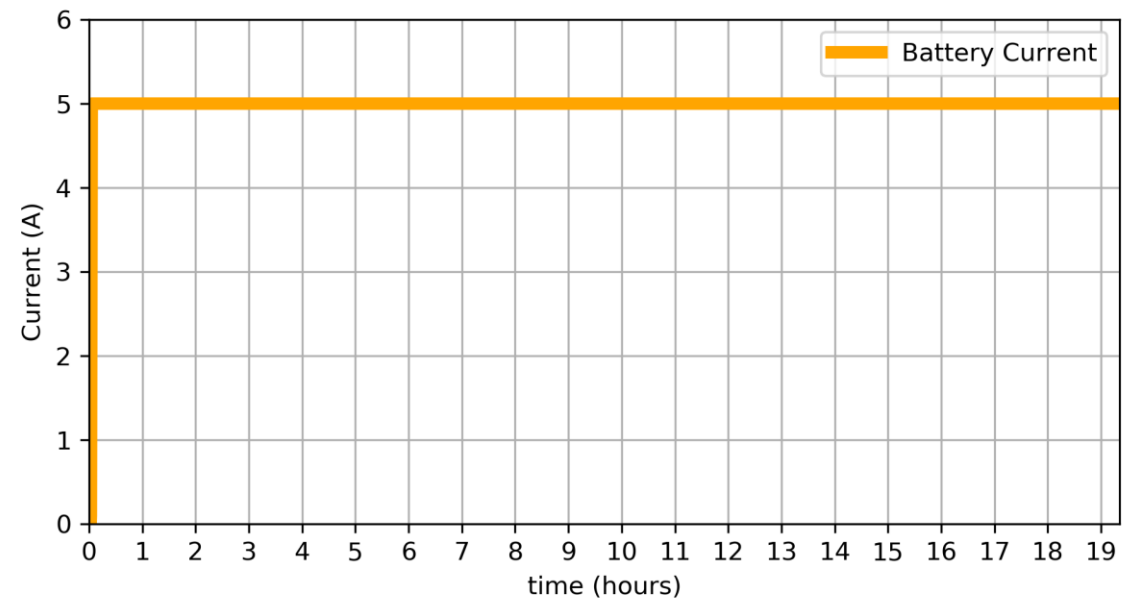
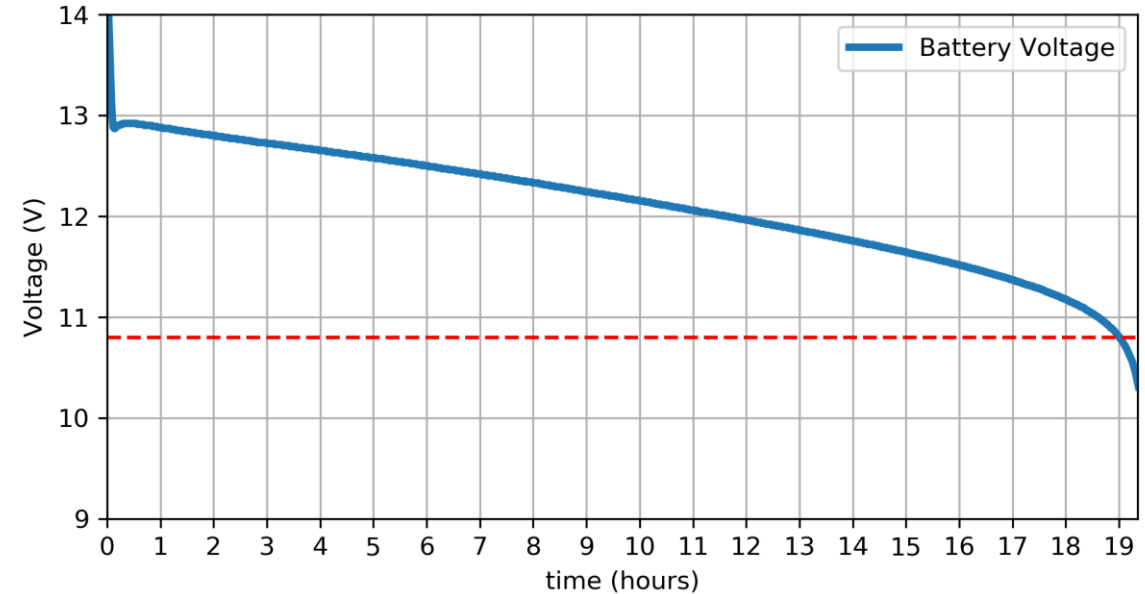

Diminishing Return

If the battery were discharged at 10A instead of 5A, it would reach the cut-off voltage in 8.5h (capacity of 85 Ah)

Increasing discharge current reduces capacity

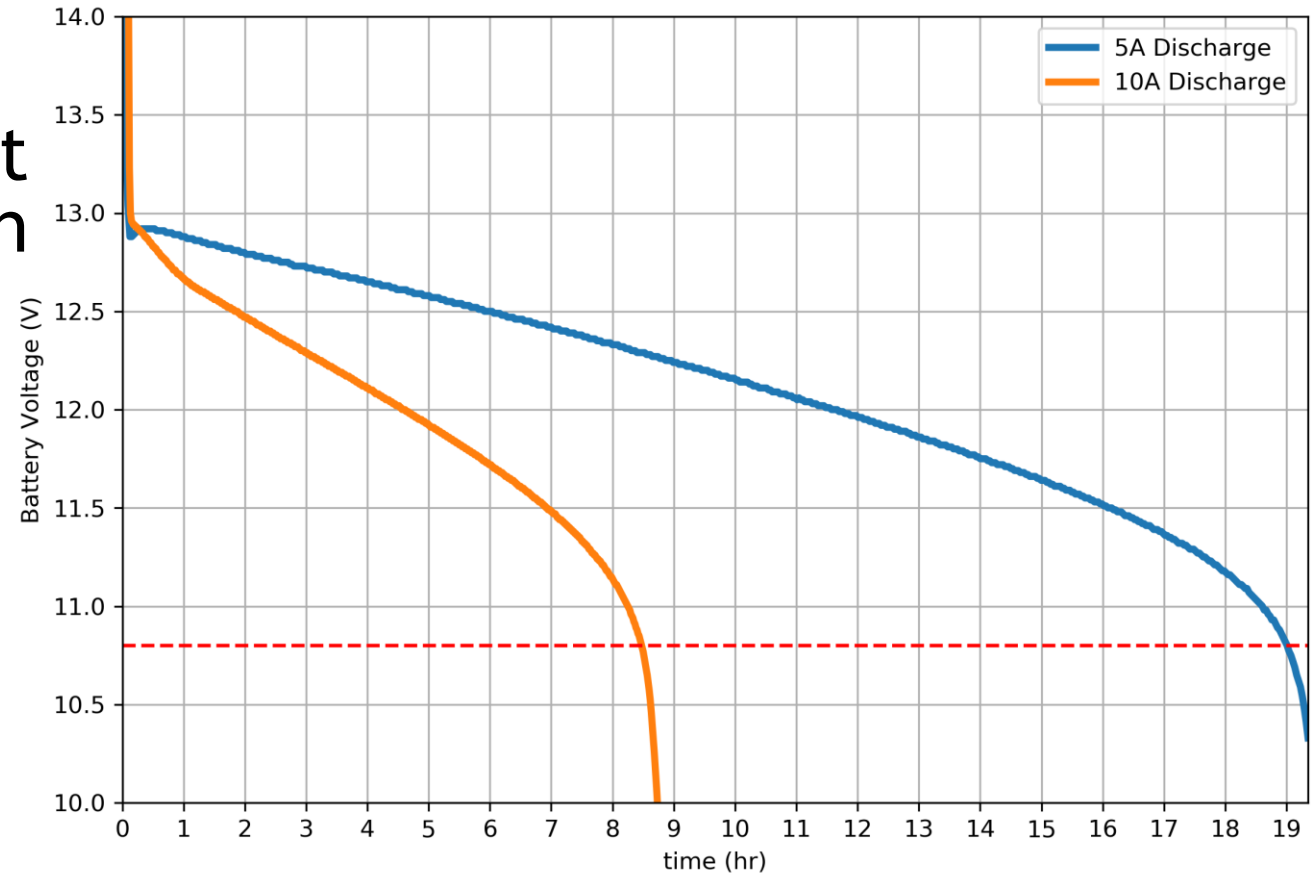

Capacity at Different Discharge Current

- A battery does not have a single capacity
 - Capacity depends on discharge current
 - Battery capacity is always in reference to a particular discharge current
- Battery from the previous slides
 - Capacity is 95 Ah at 5 A discharge
 - Capacity is 85.0 Ah at 10 A discharge
- Rather than specifying the current, spec sheets use the “C-rate” or “Hour Rate”

Immediate voltage drop from as soon as discharge starts

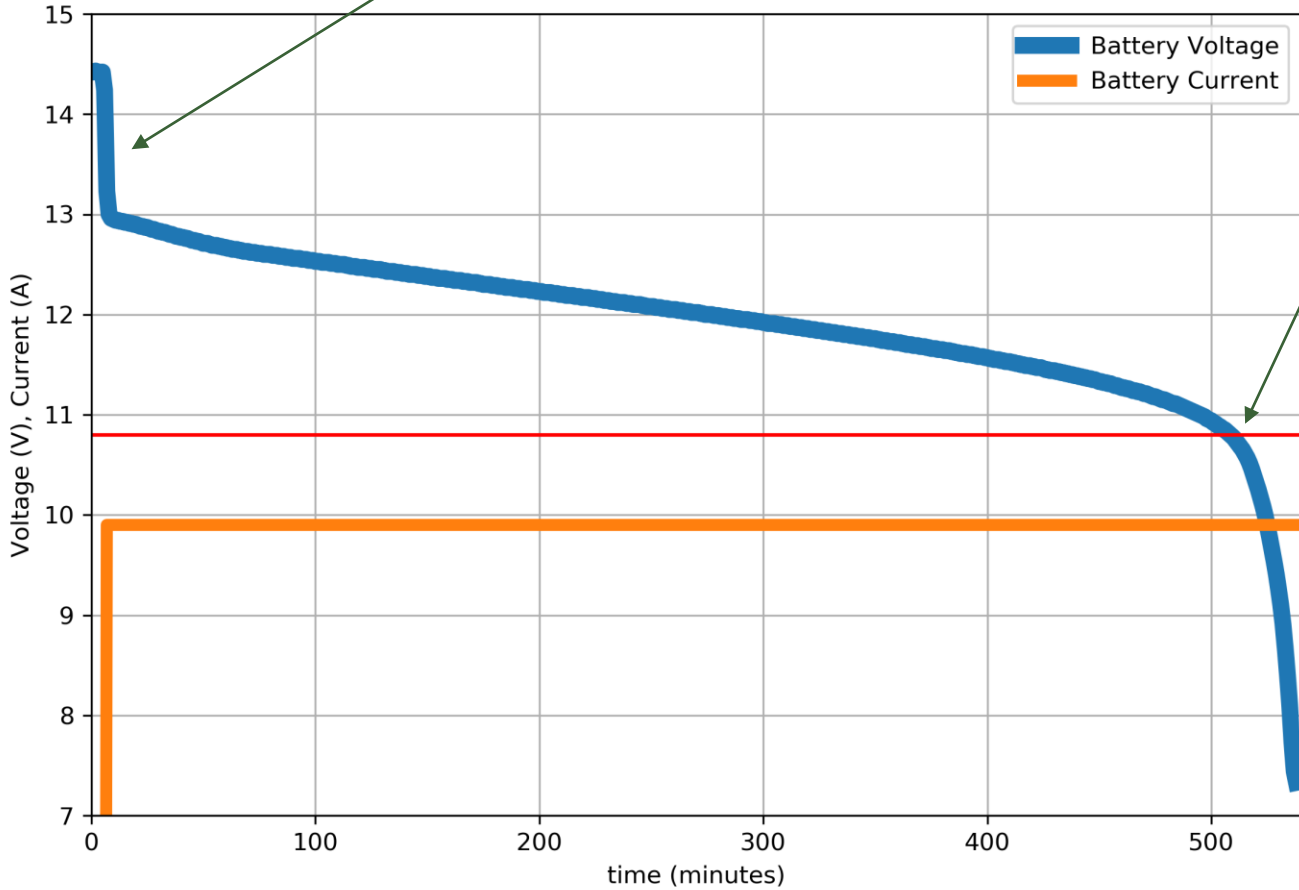

Cut-off voltage reached (10.8V) after ~510 minutes (8.5h x 10A = 85Ah)

Specifications

Article number	V	Ah C5 (10,8V)	Ah C10 (10,8V)	Ah C20 (10,8V)
BAT412110081	12	82	90	100

10 A constant discharge (12V, 100 Ah, AGM Battery)

Battery can continue to be discharged, even after the cut-off voltage has been reached, but the voltage steeply drops. An additional 20 minutes of capacity (0.33 h x 10A = 3.3Ah)

Note: data acquisition system draws an additional ~0.35A, so capacity is closer to 88Ah (very close to spec sheet value)

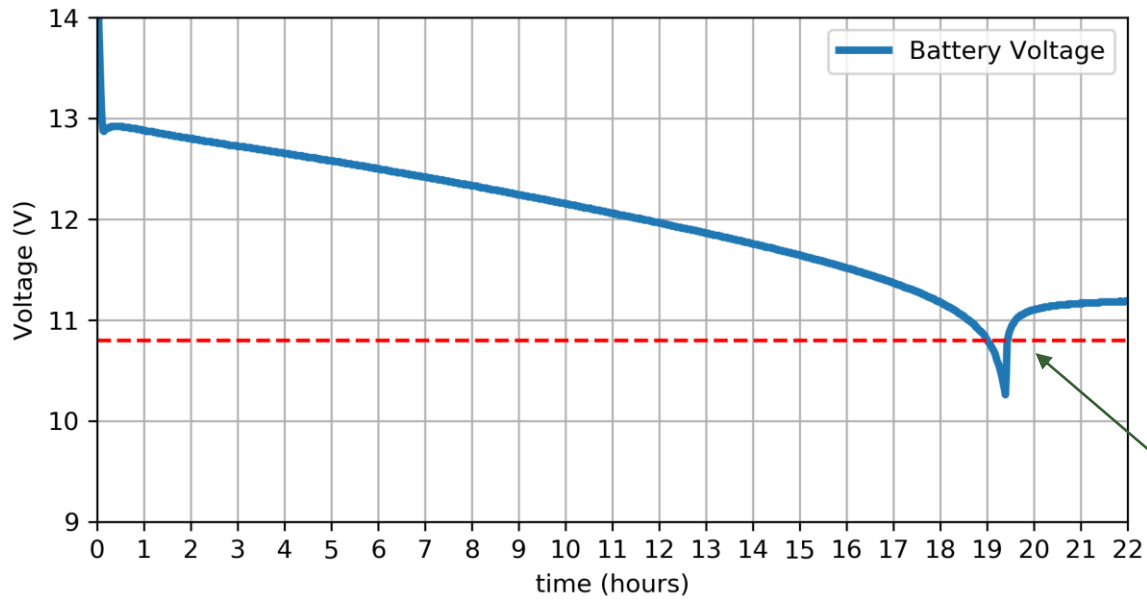

Constant current discharge of 5A should correspond to the C20 rate (100Ah capacity).
 Cut-off voltage (10.8V) reached after 19h.
 Measured capacity: $5A \times 19h = 95Ah$

Battery voltage rebounds by approx. 1V after load is removed. The voltage rebound is not due to any increase in state of charge.

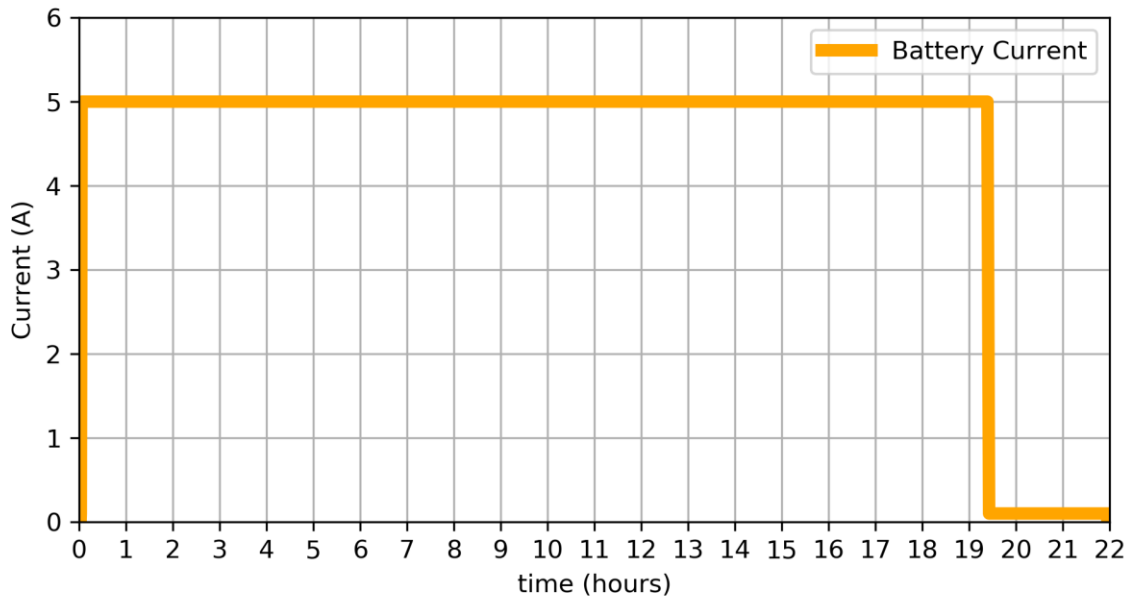

5 A constant discharge
 (12V, 100 Ah, AGM Battery)

Specifications

Article number	V	Ah C5 (10,8V)	Ah C10 (10,8V)	Ah C20 (10,8V)
BAT412110081	12	82	90	100

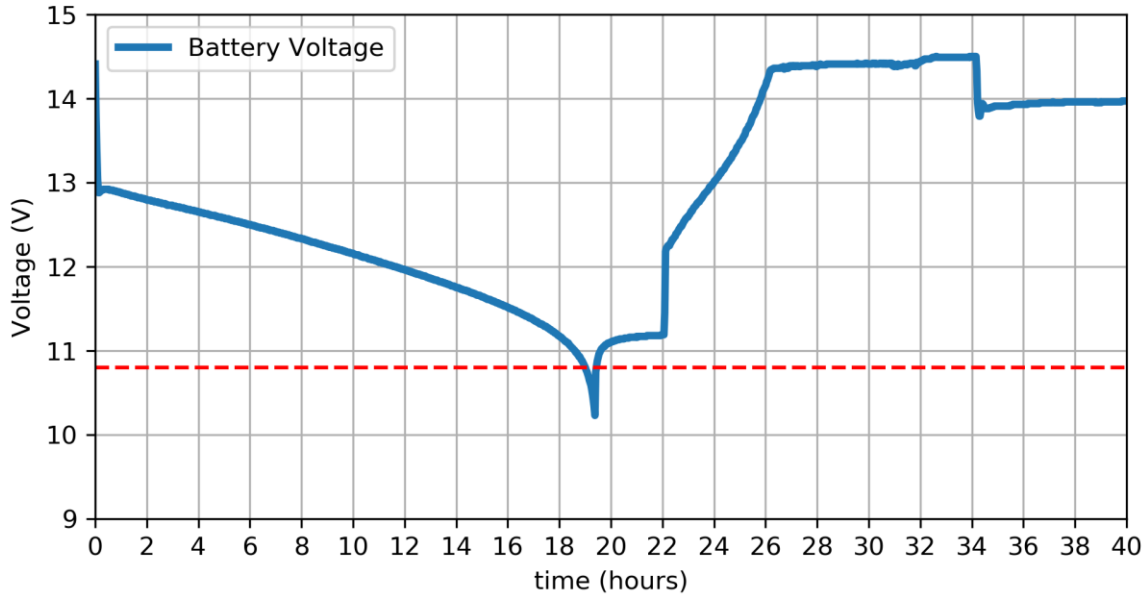

Full discharge, rest, recharge cycle.
Bulk stage is charger current limited

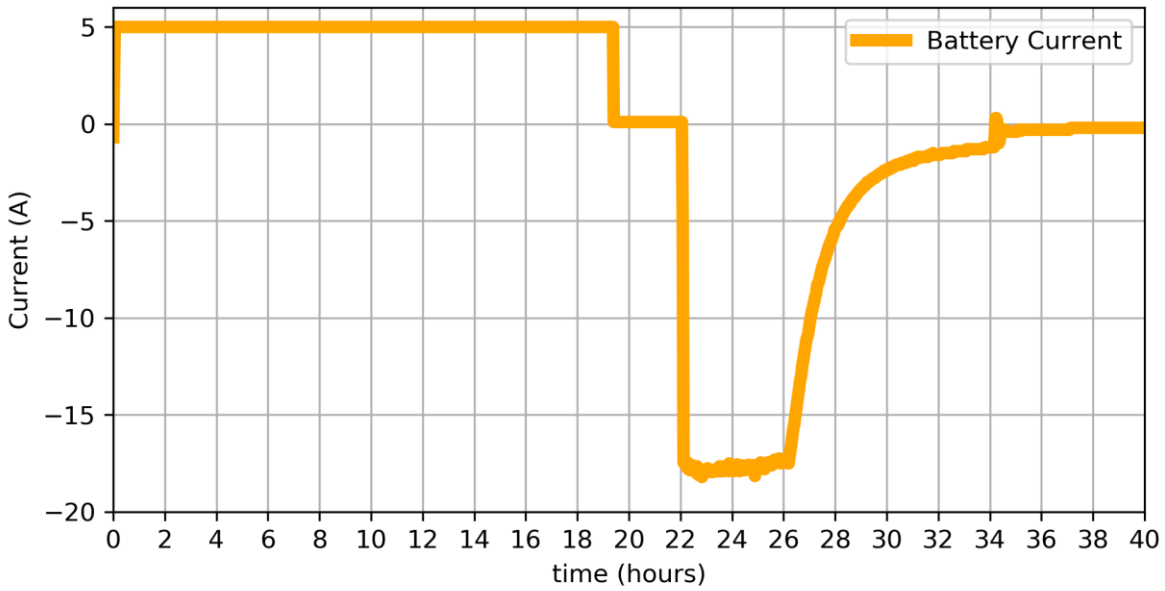

Exercise

Consider the a battery. In which discharge scenario would more active material be consumed?

- A. The battery is discharged at 10A (constant) for a period of 1 hour
- B. The battery is discharged at 1A for a period of 10 hours
- C. The same active material will be consumed in both scenarios

Exercise

Consider the a battery. In which discharge scenario would more active material be consumed?

- A. The battery is discharged at 10A (constant) for a period of 1 hour
- B. The battery is discharged at 1A for a period of 10 hours
- C. The same active material will be consumed in both scenarios

Although, if self-discharge is considered, then the answer would be B, but the difference would likely be negligible

Hour Rate

Hour rate: number of hours a battery can supply a particular constant current at until the cut-off voltage is reached

$$\text{Discharge Current} = \frac{\text{Capacity}}{\text{Hour Rate}}$$

Hour Rate	Capacity	Current
17.75	88.75 Ah	5A
8.5	85 Ah	10A

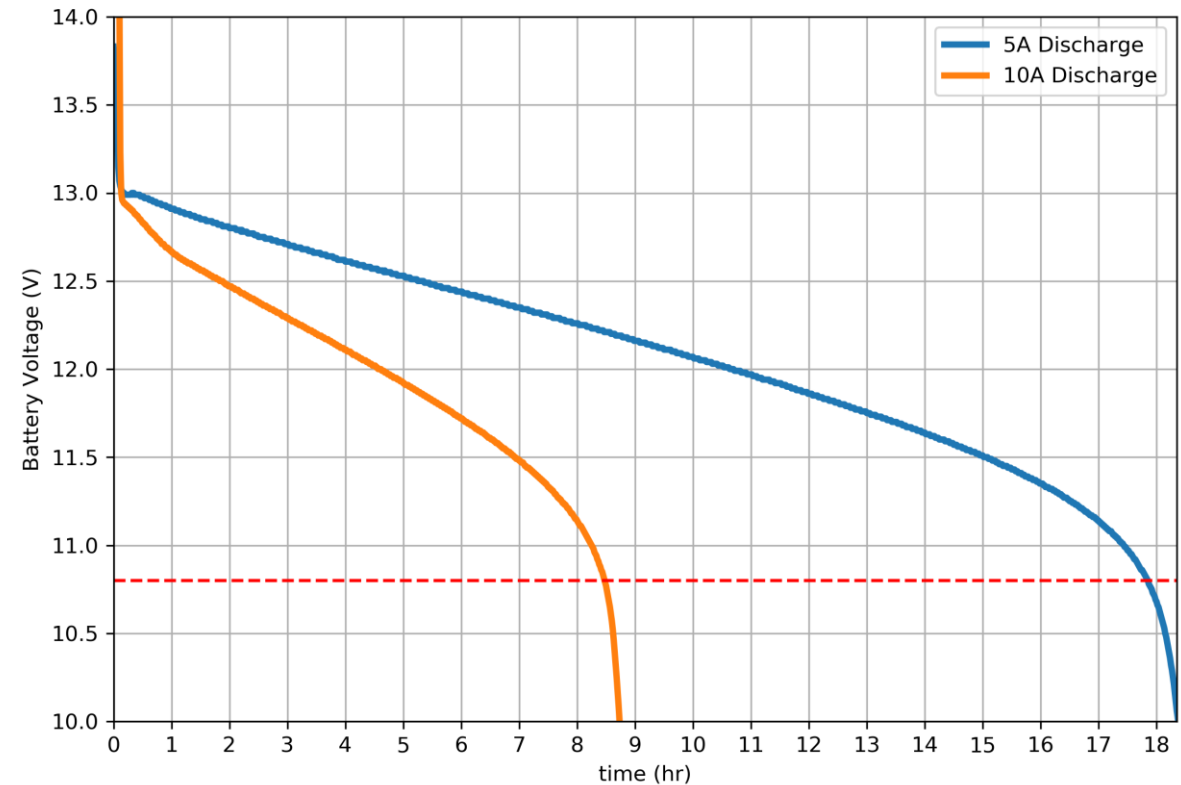

C-Rate

- C-rate: “charge” rate. Inverse of hour-rate
 - Units: 1/hour
 - Discharge Current = C-Rate x Capacity
- Can be thought of as the percent of the capacity that is discharged each hour at a particular current
- Most lead-acid battery capacities are in reference to a C-rate of 0.05C

C-Rate Examples

- C-rate of 0.1C for a 100Ah capacity refers to a current of $0.1 \times 100 = 10\text{A}$ (this battery will last 10 hours when discharged at 10A)
- C-rate of 0.05C for a 400Ah capacity refers to a current of $0.05 \times 400 = 20\text{A}$ (this battery will last 20 hours when discharged at 20A)

The “C” in 0.1C is not itself a unit, it just signifies that it is a C-rate

Putting it all together

In other words:

A “100 Ah” battery when discharged at $0.05 \times 100 = 5A$ will last 20 hours before its terminal voltage drops below the cut-off voltage.

If discharged above 5A,
the battery will last less
than 20 hours and
provide less than 100 Ah
of charge

Example

1. Compute the current corresponding to a C-rate of 0.25 for a 60Ah battery.
2. Compute the hour rate corresponding to a C-rate of 0.01.

Example

1. Compute the current corresponding to a C-rate of 0.25 for a 60Ah battery.

$$\text{Current} = \text{Capacity} \times \text{C-rate} = 60 \times 0.25 = 15\text{A}$$

2. Compute the hour rate corresponding to a C-rate of 0.01.

$$\text{Hour rate} = 1/\text{C-rate} = 100 \text{ hr}$$

Capacity Table

	10-Hour Rate (0.10C)	20-Hour Rate (0.05C)	48-Hour Rate (0.021C)	72-Hour Rate (0.014)	100-Hour Rate (0.01C)
Battery A	136 Ah	153 Ah	157 Ah	164 Ah	170 Ah
Battery B	192 Ah	209 Ah	214 Ah	223 Ah	230 Ah
Battery C	211 Ah	229 Ah	237 Ah	247 Ah	255 Ah

Discharged at
 $21.1\text{Ah}/10\text{h} = 21.1\text{ A}$

decreasing current, increasing capacity

Discharged at
 $255\text{Ah}/100\text{h} = 2.55\text{ A}$

Exercise

Compute the C-rate and corresponding discharge current for the Trojan SAGM 06 375

ELECTRICAL SPECIFICATIONS

Voltage	Capacity ^A Amp-Hours (Ah)				
6V	10-Hr	20-Hr	48-Hr	72-Hr	100-Hr
	329	375	389	394	400

Exercise

Compute the C-rate and corresponding discharge current for the Trojan SAGM 06 375

ELECTRICAL SPECIFICATIONS

Voltage	Capacity ^A Amp-Hours (Ah)				
6V	10-Hr	20-Hr	48-Hr	72-Hr	100-Hr
	329	375	389	394	400
	0.1 C	0.05C	0.021C	0.014C	0.01C
	32.9A	18.75A	8.10A	5.47A	4A

Capacity Curves

- Show the charge capacity at different discharge rates
- Plot of the terminal voltage versus time
- Example:
 - When discharged at a rate of 0.10C (5.6A) the battery lasts 10 hours, supplying 56Ah until the cut-off voltage of 1.7 V/cell is reached

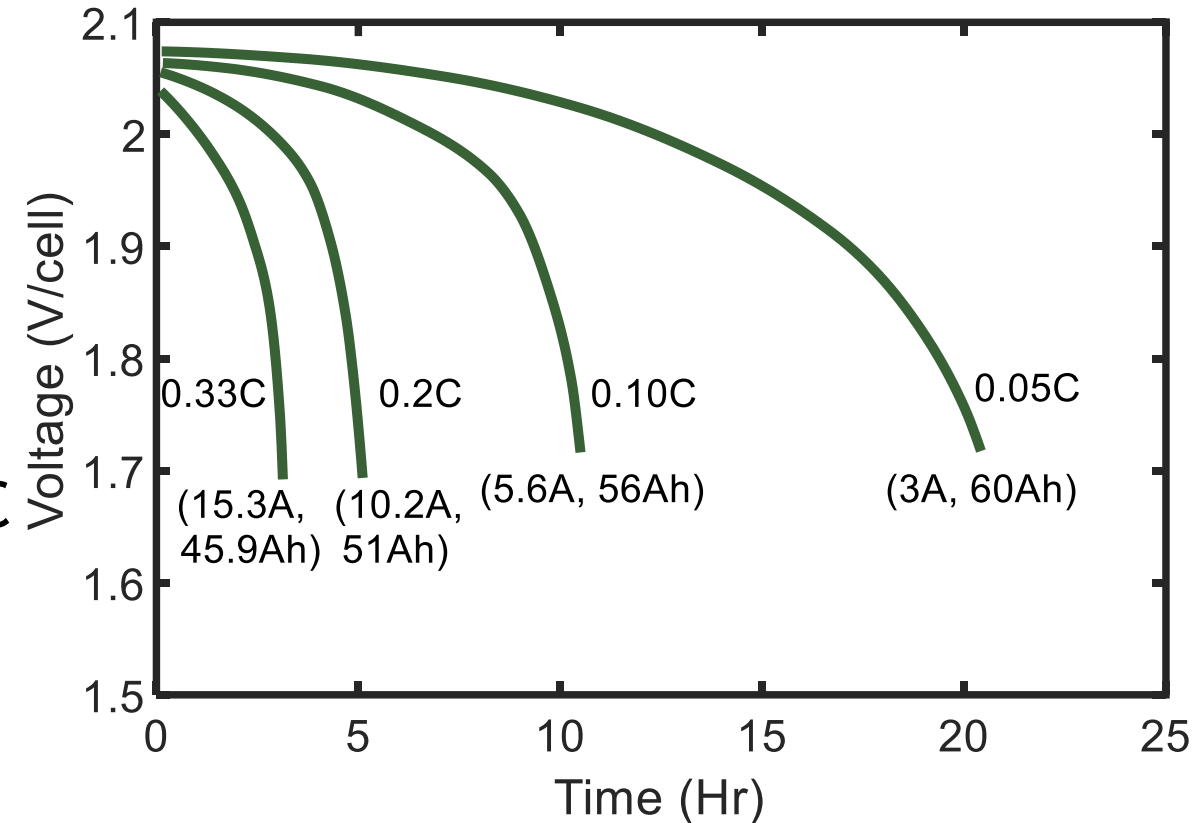

What we mean by a battery's capacity

- Common practice for off-grid systems is to refer to the capacity of a battery based on its 20-hour rate (C-rate of 0.05)
 - Using this convention, the capacity of the Trojan SAGM 06 375 battery is 375 Ah
- Note: in other applications a different hour rate is used
 - Example: 1 hour rate (C-rate of 1) is common for small dry cell and lithium ion batteries

20-Hour Rate

- 20-hour rate is the assumed rate when only the capacity is reported
- Battery can supply 56.20 A for 20 hours before cut-off voltage is reached

CAPACITY **1124 AH**

HOUR RATE:	SPECIFIC GRAVITY	CAPACITY / AMP HOUR	CURRENT / AMPS
@ 100 HOUR RATE	1.280	1452	14.52
@ 72 HOUR RATE	1.280	1376	19.11
@ 50 HOUR RATE	1.280	1312	26.24
@ 24 HOUR RATE	1.280	1157	48.21
@ 20 HOUR RATE	1.280	1124	56.20
@ 15 HOUR RATE	1.280	1057	70.44
@ 12 HOUR RATE	1.280	1000	83.36
@ 10 HOUR RATE	1.280	955	95.54
@ 8 HOUR RATE	1.280	899	112.40
@ 6 HOUR RATE	1.280	832	138.63
@ 5 HOUR RATE	1.280	787	157.36

Peukert's Equation

- We are often interested in the capacity of the battery at rates not specified by the capacity table
 - How long will this battery last if discharged at 50A?
- Use *Peurkert's Equation* to estimate

HOUR RATE:	SPECIFIC GRAVITY	CAPACITY / AMP HOUR	CURRENT / AMPS
@ 100 HOUR RATE	1.280	1452	14.52
@ 72 HOUR RATE	1.280	1376	19.11
@ 50 HOUR RATE	1.280	1312	26.24
@ 24 HOUR RATE	1.280	1157	48.21
@ 20 HOUR RATE	1.280	1124	56.20
@ 15 HOUR RATE	1.280	1057	70.44
@ 12 HOUR RATE	1.280	1000	83.36
@ 10 HOUR RATE	1.280	955	95.54
@ 8 HOUR RATE	1.280	899	112.40
@ 6 HOUR RATE	1.280	832	138.63
@ 5 HOUR RATE	1.280	787	157.36

Peukert's Equation

- Peukert's equation is used to estimate the capacity c_x at a discharge current x , from a known (rated) capacity at discharge current x_r based on a “ k ” an estimated parameter known as Peukert's exponent

$$c_x = c_{x_r} \left(\frac{x_r}{x} \right)^{k-1}$$

- Peukert's equation is not a “law”, it is based on empirical observations, not any underlying physical law---expect errors

Peukert's Exponent

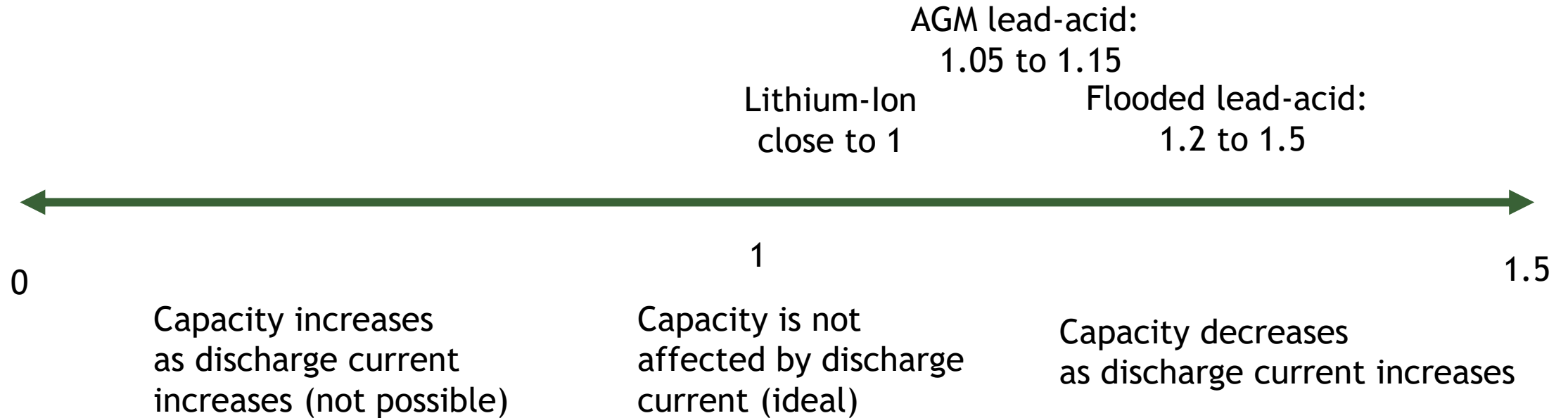

Peukert's Exponent can also be estimated from a capacity table (see problem 8.7)

CAPACITY

1124 AH

Example

How long will this battery last if discharged at 50A? Assume $k = 1.25$

HOUR RATE:	SPECIFIC GRAVITY	CAPACITY / AMP HOUR	CURRENT / AMPS
@ 100 HOUR RATE	1.280	1452	14.52
@ 72 HOUR RATE	1.280	1376	19.11
@ 50 HOUR RATE	1.280	1312	26.24
@ 24 HOUR RATE	1.280	1157	48.21
@ 20 HOUR RATE	1.280	1124	56.20
@ 15 HOUR RATE	1.280	1057	70.44
@ 12 HOUR RATE	1.280	1000	83.36
@ 10 HOUR RATE	1.280	955	95.54
@ 8 HOUR RATE	1.280	899	112.40
@ 6 HOUR RATE	1.280	832	138.63
@ 5 HOUR RATE	1.280	787	157.36

CAPACITY

1124 AH

Example

How long will this battery last if discharged at 50A? Assume $k = 1.25$

$$C_x = C_{x_r} \left(\frac{x_r}{x} \right)^{k-1}$$

Pick the rated current that is closest to the current of interest

$$C_{50} = 1157 \left(\frac{48.21}{50} \right)^{1.25-1} = 1146.5 \text{ Ah}$$

$$T_{d,50} = \frac{C_{50}}{50} = 22.93 \text{ hours}$$

HOUR RATE:	SPECIFIC GRAVITY	CAPACITY / AMP HOUR	CURRENT / AMPS
@ 100 HOUR RATE	1.280	1452	14.52
@ 72 HOUR RATE	1.280	1376	19.11
@ 50 HOUR RATE	1.280	1312	26.24
@ 24 HOUR RATE	1.280	1157	48.21
@ 20 HOUR RATE	1.280	1124	56.20
@ 15 HOUR RATE	1.280	1057	70.44
@ 12 HOUR RATE	1.280	1000	83.36
@ 10 HOUR RATE	1.280	955	95.54
@ 8 HOUR RATE	1.280	899	112.40
@ 6 HOUR RATE	1.280	832	138.63
@ 5 HOUR RATE	1.280	787	157.36

Other Forms of Peukert's Equation

$$C_x = C_{x_r} \left(\frac{x_r}{x} \right)^{k-1}$$

$C_1 = x^k T$ (only useful if the capacity at 1A discharge is known)

$$T_{d,x} = T_{d,x_r} \left(\frac{C_{x_r}}{x T_{d,x_r}} \right)^k$$

Exercise

A battery in an off-grid system is rated at 105Ah when discharged at 5.25 A. What is the capacity when discharged at 11.7 A? What is the corresponding C-rate? Let $k = 1.18$.

Exercise

A battery in an off-grid system is rated at 105Ah when discharged at 5.25 A. What is the capacity when discharged at 11.7 A? What is the corresponding C-rate? Let $k = 1.18$.

$x = 11.7$ A (the discharge current of interest)

$x_r = 5.25$ A (the discharge current of the capacity we know)

$$C_{11.7} = C_{x_r} \left(\frac{x_r}{x} \right)^{k-1} = 105 \left(\frac{5.25}{11.7} \right)^{1.18-1} = 90.90 \text{ Ah}$$

State-of-Charge (SoC)

State-of-Charge (SoC): the percent of a battery's charge capacity remaining in the battery at a point in time. Put another way, it is the remaining charge that a battery can meaningfully discharge (i.e. without dropping below the cut-off voltage)

State-of-Charge (SoC)

- SoC is computed as:

$$\text{SoC} = 100 \times \frac{c_x - \int_0^{T_{\text{use}}} i_B(t) dt}{c_x}$$

T_{use} : is the duration the battery has been in use (either charging or discharging)

- Example: A battery with capacity $c_{35} = 350$ Ah that has been discharged for 6 hours at 35A has a SoC of

$$\text{SoC} = 100 \times \frac{c_x - \int_0^{T_{\text{use}}} i_B(t) dt}{c_x} = 100 \times \frac{350 - \int_0^6 35 dt}{350} = 40\%$$

Exercise

A lead-acid battery can have a negative SoC.

- A. True
- B. False

Exercise

A lead-acid battery can have a negative SoC.

A. True

B. False

One way of this happening is the battery being discharged past the cut-off voltage

Side Note on State-of-Charge

- Strictly defined, the SoC is not that useful
 - Self-discharge is not accounted for
 - Aging is not accounted for
 - If the discharging is not constant current, what value of c_x to use is not clear
- Still, it is a useful approximation but it is extremely difficult to accurately know the true state-of-charge of a battery

$$\text{SoC} = 100 \times \frac{c_x - \int_0^{T_{\text{use}}} i_B(t) dt}{c_x}$$

Depth-of-Discharge (DoD)

- Depth-of-Discharge (DoD): percent of the rated capacity that has been discharged:

$$DoD = 100 \times \frac{\int_0^{T_{use}} i_B(t) dt}{C_x}$$

- SoC and DoD are related by:

$$DoD = 100 - SoC$$

Charge Capacity of 100 Ah Battery when discharged at 0.05C (5A)

Assume 5A have continuously been supplied to the load for six hours (30Ah)

The battery is at:
30% depth-of-discharge (DoD),
70% state-of-charge (SoC)

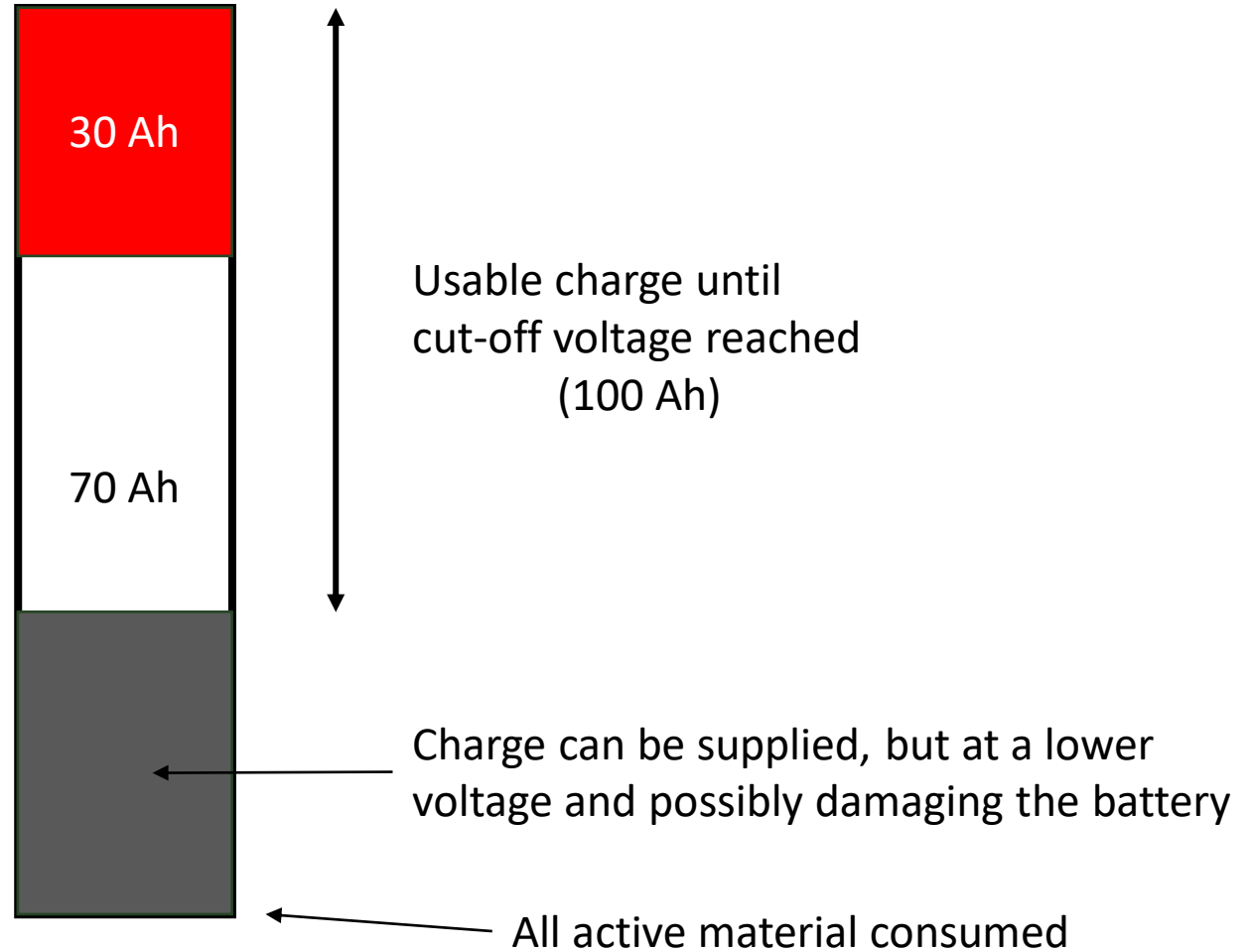

Energy Capacity

- Electrical engineers are often more familiar with working in units of kilowatthours than amphotours
 - AC load is often expressed in kilowatts and kilowatthours
- Energy capacity: *energy* that a battery can supply at a particular current before its voltage drops before a manufacturer-defined cut-off voltage

Energy Capacity

- Energy capacity when discharged at a constant current x is computed from:

$$e_x = x \int_0^{T_{d,x}} v_B(t) dt$$

$V_B(t)$: terminal voltage, (V)

- Current is constant, but voltage will vary over time

Energy Capacity Versus Charge Capacity

- Energy capacity accounts for the voltage of the battery, while charge capacity does not
- Energy capacity is expressed in kilowatthours while charge capacity is expressed in amphours
- Energy capacity can be approximated (inaccurately) from the charge capacity as:

$$\hat{e}_x = c_x \times V_{\text{nom}}$$

\hat{e}_x : estimated energy capacity (Wh)
 V_{nom} : nominal voltage (V)

Approx. Energy Capacity

- The approximate energy capacity of this battery at the 20-hour rate is:

$$x = \frac{375 \text{ Ah}}{20 \text{ h}} = 18.75 \text{ A (this isn't required, but it is helpful for notation)}$$

$$\hat{e}_x = c_x \times V_{\text{nom}}$$

$$\hat{e}_x = c_{18.75} \times 6 = 375 \times 6 = 2.25 \text{ kWh}$$

MODEL SAGM 06 375
 VOLTAGE 6V
 CAPACITY 375Ah @ 20Hr
 MATERIAL Polypropylene
 BATTERY VRLA AGM / Non-Spillable / Maintenance-Free
 COLOR Maroon
 WATERING No Watering Required 
 IEC 61427 8+ Years Life



PRODUCT + PHYSICAL SPECIFICATIONS

Model	Terminal Type ⁰	Dimensions ^A Inches (mm)			Weight Lbs. ^F (kg)	Handles	Installation Orientation
		Length	Width	Height ^C			
SAGM 06 375	M8/LT	11.66 (296)	6.94 (176)	16.31 (414)	114 (52)	Braided Rope	Horizontal and Vertical

ELECTRICAL SPECIFICATIONS

Voltage	Capacity ^A Amp-Hours (Ah)					Energy kWh	Internal Resistance (mΩ)	Short Circuit Current (A)
	10-Hr	20-Hr	48-Hr	72-Hr	100-Hr			
6V	329	375	389	394	400	2.25	1.7	3650

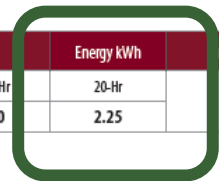

Efficiency

- Batteries are not 100% efficient
- Typical range of lead acid battery efficiency is approx. 70 to 90%, but this depends on many factors
- Read Chapter 8.5.4 for details

Temperature Dependence

Increased temperature leads to:

- Decreased internal impedance
- Increased capacity
- Increased open-circuit voltage
- Increased self-discharge
- Decreased life cycle

Read Chapter 8.5.7

SELF DISCHARGE VS. TIME^E

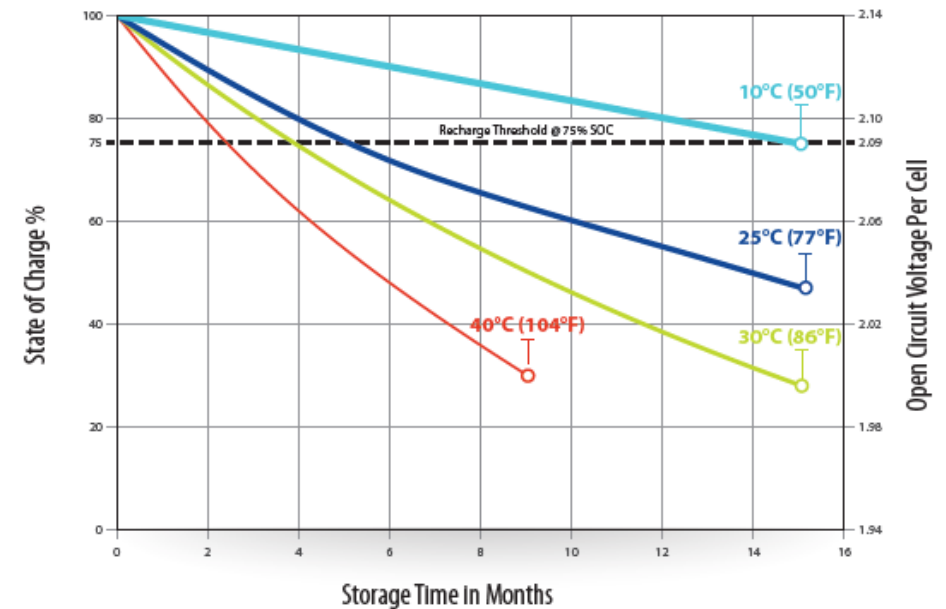

Cycle Life

- Batteries degrade over time and with use
- End of life when maximum charge capacity drops to 80% of rated (new) capacity
- Depth-of-Discharge affects number of times battery can be “cycled” before end-of-life capacity is reached

Typical cycle is one 24-hour period of charging/discharging

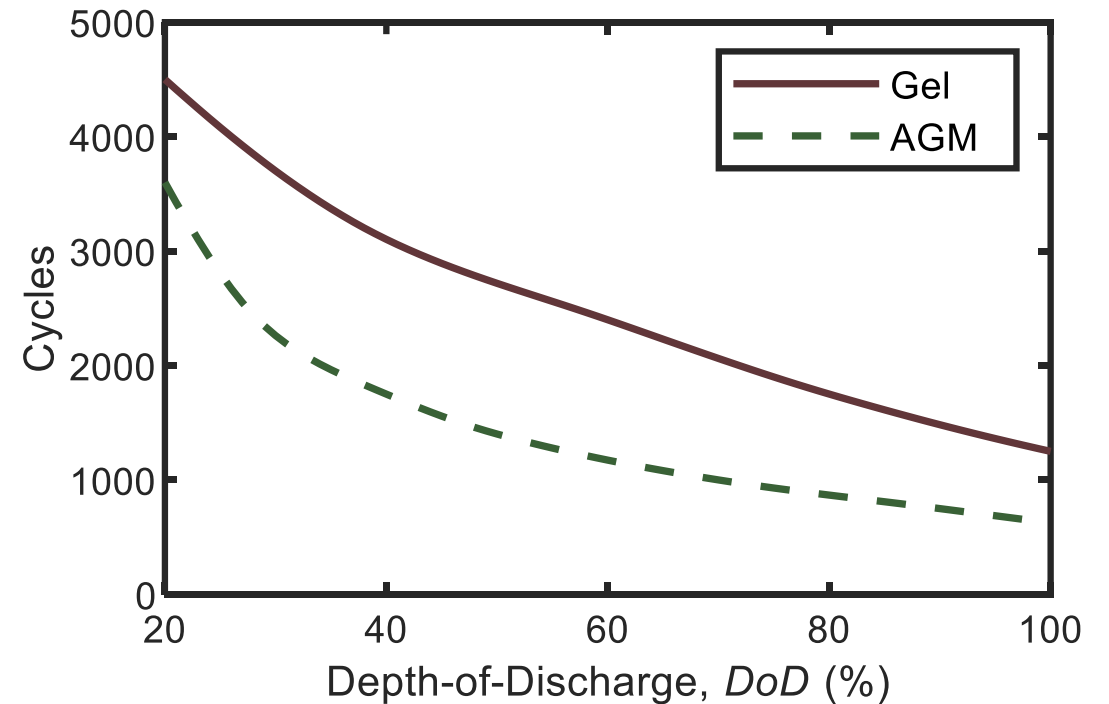

Exercise

If 225Ah are discharged over a 20-hour period from the Trojan SAGM 06 375 battery each day, estimate the number of years the battery will last before it reaches the end of its life.

Exercise

If 225Ah are discharged over a 20-hour period from the Trojan SAGM 06 375 battery each day, estimate the number of years the battery will last before it reaches the end of its life.

Assume load is constant. $225/375 = 60\%$ DoD. This corresponds to approx. 1400 cycles, or $1400/365 = 3.84$ years.

Real World Conditions

- Most everything in this lecture is based on constant current assumptions
- Constant current conditions rarely occur in off-grid systems:
 - Constant power and constant impedance loads will not draw constant current from a battery
 - Load changes throughout the day
- What do we do?

Real World Conditions

- Interpret every calculation as an estimate or approximation only (besides, most models ignore temperature and age of the battery)
- Use either the maximum current or the average current as the “constant current” in the equations
 - BUT do not approximate the total discharge

Example

- Let the daily charge be 194.4 Ah, with a maximum current of 15 A and an average current of 8.1 A
- Select a battery whose capacity is at least

$$C_{15} = 194.4 \text{ Ah OR}$$

$$C_{8.1} = 194.4 \text{ Ah}$$

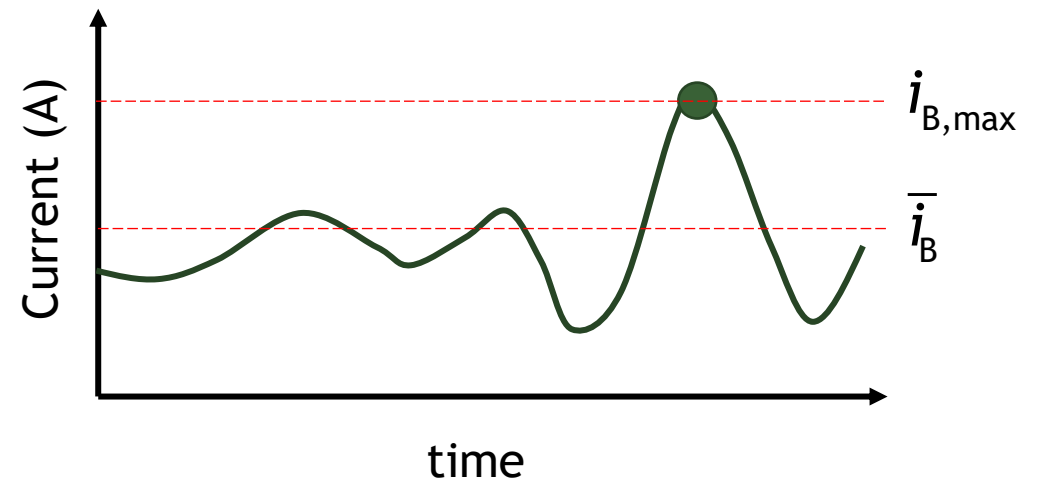

C_{15} is a more conservative choice,
but the battery will be more expensive

Contact Information

Henry Louie, PhD

Professor

Seattle University

 @henrylouie

hlouie@ieee.org

Office: +1-206-398-4619