

REUSABLE SHOPPING BAG

BY DYLAN M.



DIFFICULTY
■ □ □

THIS BAG IS

modeled after my favorite grocery bags that I've gotten from Trader Joes. Their height in particular make them rockstars at holding your tetris-arranged grocery goodies. Sewing with oilcloth is easy, but keep in mind the following:

- The more stitches = the more perforations, so use larger stitch lengths, limit back-stitching, and try to get it right on the first pass.
- Get rid of wrinkles by using a cool iron and press cloth, working from the wrong side of the fabric.
- Don't be alarmed if your presser foot sticks to the oilcloth. Some machines won't have an issue, but if yours does, simply sew over a piece of tissue paper or scotch tape to help the foot slide more easily over the material, tearing away when finished. However, other than the hem, all seams in this bag are sewn **RST (Right Sides Together)**, so there shouldn't be much sticking. 😊

Seam allowances are $\frac{3}{8}$ " unless stated otherwise.

MATERIALS

- 1 Yard Oilcloth*
- 1½ Yards Polyester or Cotton Strapping
- Size 16 Denim Needle
- Coordinating Thread

TOOLS

- Sewing Machine
- Iron & Ironing Surface
- Press Cloth
- Ruler & Cutting Surface
- Scissors/Rotary Cutter
- Water soluble marking pen
- Clover Wonder/Binder Clips

*I bought my oilcloth from fabric.com, but I've also spied some beauties at oilclothbytheyard.com

CUT LIST

- **2** Front/Back Pieces $12\frac{3}{4}$ " x $16\frac{5}{8}$ "
- **2** Side Pieces (a & b) $7\frac{3}{4}$ " x $16\frac{5}{8}$ "
- **1** Bottom Piece $12\frac{3}{4}$ " x $7\frac{1}{4}$ "
- **2** 22" Straps

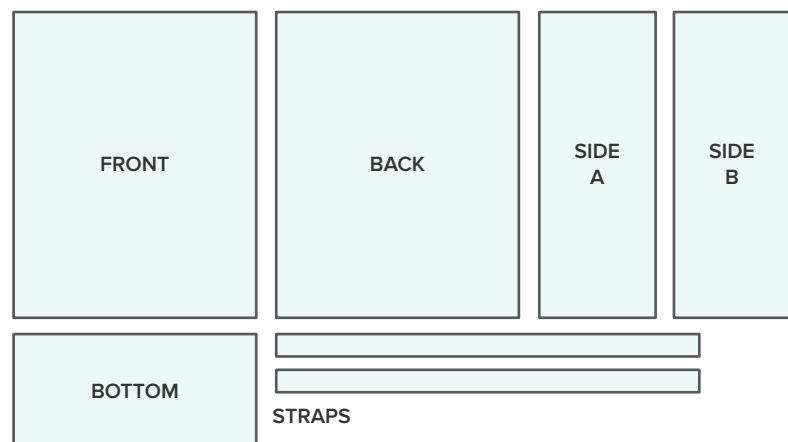

REUSABLE SHOPPING BAG PATTERN



PREP PIECES

A IRON OUT ANY WRINKLES

See aside (pg 1). Iron fabric from wrong side with a cool iron, protect oilcloth with a press cloth.

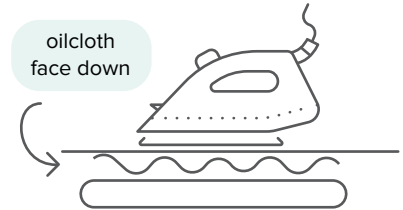

B HEM FRONT, BACK, AND SIDES

With **FRONT**, **BACK**, **SIDE A**, and **SIDE B** pieces face down, fold back the top $\frac{1}{4}$ ", followed by another $\frac{1}{4}$ ". Clip in place and sew at $\frac{1}{8}$ "

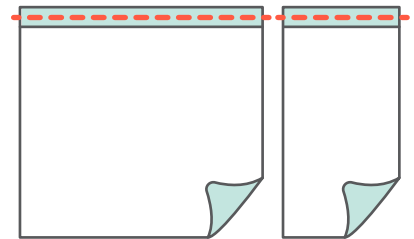

C FINISH THE STRAP ENDS

Finish the ends of each strap piece by either A) If your strapping is synthetic, carefully burn/melt the edges with a lighter or B) If your strapping is cotton, zigzag stitch across the edge with coordinating thread

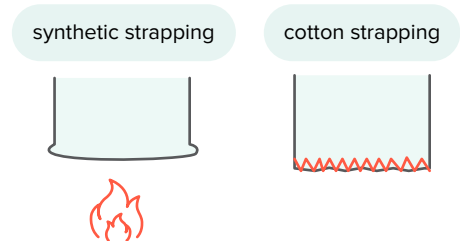

CREASE SIDES

With **SIDE A** face down, mark the center line using a ruler and water soluble pen. Mark a second line $\frac{1}{4}$ " to the left. Fold along the center line, RST and stitch along the second line.

Erase marks with a damp paper towel and repeat for **SIDE B**.

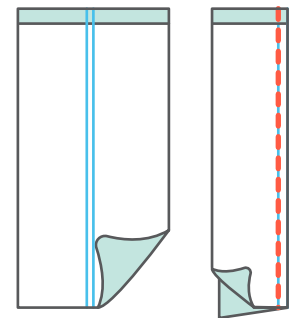

ATTACH STRAPS

With **FRONT** and **BACK** pieces face up, measure and mark 3" from each side, and 2" down from the top, this is where the raw edge of each strap piece will be placed. Take care in not twisting the straps when marking and clipping in place.

Stitch in place close to the straps' edge, forming a box with an 'x' in it for added durability.

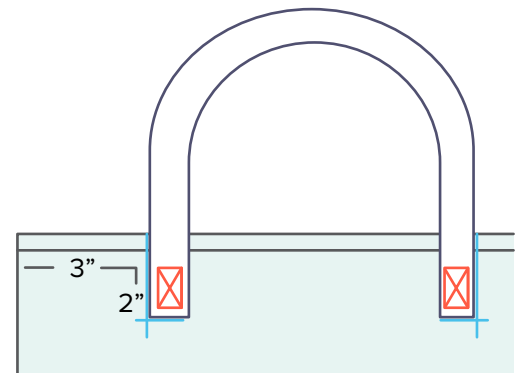

REUSABLE SHOPPING BAG PATTERN



ASSEMBLE WALLS

Begin with the **FRONT** piece facing right side up. Place **SIDE A** RST along the right edge of the **FRONT** piece. Stitch at $\frac{3}{8}$ ", backstitching at the top and stopping and backstitching $\frac{3}{8}$ " from the bottom. Repeat with the **BACK** piece on top of **SIDE A**, followed by **SIDE B** on top of the **BACK** piece. Finish by lining up the raw edges of the **FRONT** piece and **SIDE B** RST, finishing the loop of connected bag side pieces. Keep inside out.

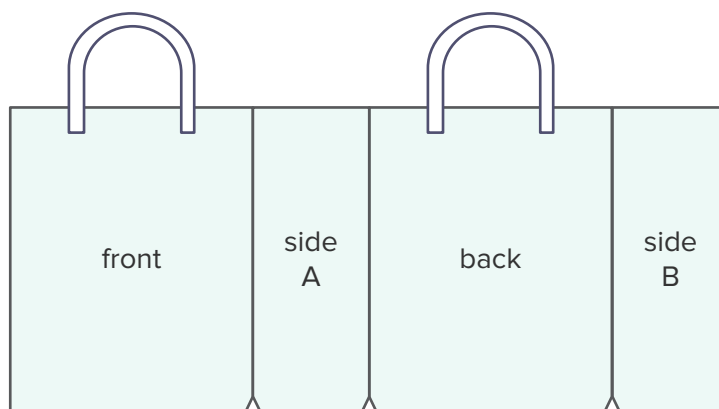

ATTACH BOTTOM

With the bag still inside out from the last step, start lining up the bottom of one side of the bag with the coordinating side of the bottom piece RST. Clip in place and continue around the perimeter of the bag base. Sew at $\frac{3}{8}$ ", stopping with your needle down $\frac{3}{8}$ " away from each corner, pivoting, and continuing to sew. Backstitch when you reach your starting point.

Optional and recommended: Using a needle and thread, reinforce the joined corners at the bottom.

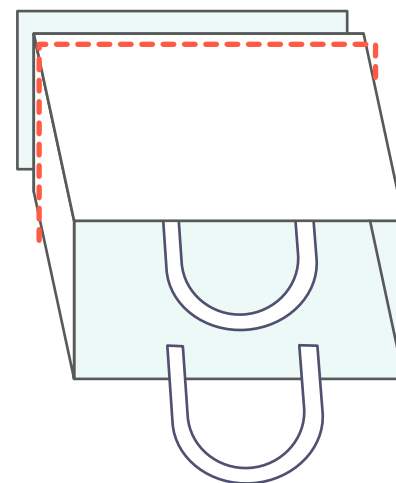

TURN RIGHT-SIDE OUT & ENJOY!