

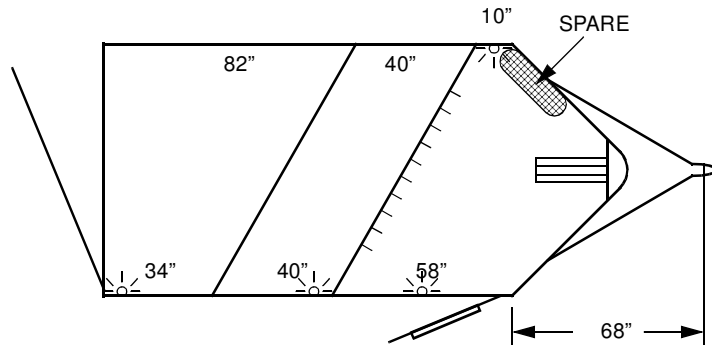

**PLATINUM
MANUFACTURING**

2-H STOCK-COMBO BUMPER PULL PLATINUM SERIES 7' X 11' X 7' XB7112C



TOWING

2 5/16" BULLDOG COUPLER (12,500# RATING)
SAFETY CHAINS WITH SAFETY HOOK LATCHES
7-WAY FLAT PRONG PLUG & CABLE
A-FRAME JACK WITH REMOVABLE CASTER
BREAK-AWAY KIT

STANDARD FEATURES

WEDGE NOSE
PERMANENT SLANT BULKHEAD WALL
FLAT TREAD PLATE FLOOR
FULL WIDTH REAR STOCK DOOR WITH TWO AIR CRACKS AT TOP (NO SLIDER)
DRESSING ROOM DOOR (LINE) WITH WINDOW AND CAMPER LATCH WITH DEAD BOLT
SINGLE SIDE WALL CONSTRUCTION, WITH TWO AIR CRACKS AT TOP IN HORSE COMPARTMENT AND
SMOOTH SKIN AT TOP IN DRESSING ROOM AREA
BULKHEAD WALL AND FENDER WELLS ARE RUBBER LINED
DIVIDERS WITH STAINLESS STEEL SLAM LATCHES
INSIDE TIES (TWO PER HORSE)
OUTSIDE TIES (TWO PER HORSE)
SADDLE RACKS (ONE PER HORSE)
TEN BRIDLE HOOKS
PADDING IN HORSE COMPT. ON BULKHEAD WALL AND EACH SIDE OF DIVIDERS
CARPET ON SADDLE RACKS
CARPET ON FLOOR OF DRESSING ROOM AREA
FLOOR MATS COVERING ENTIRE HORSE COMPARTMENT
TAPER INNER WHEEL WELLS UP & TEAR DROP FENDERS
FULL WIDTH RUBBER DOCK BUMPER
FOUR INTERIOR L.E.D. LIGHTS
TWO PAIRS OF FULLY ENCLOSED L.E.D. TAIL LIGHTS
D.O.T. APPROVED L.E.D. RUNNING LIGHTS

WHEELS & TIRES

FIVE 15 X 6 STEEL WHEELS
FIVE 225/75R15 6-PLY RADIAL TIRES
FOUR HUB CAPS (BABY MOONS)
SPARE TIRE CARRIER

AXLES

102" WIDE RUBBER TORSION
3500# 5-BOLT ELECTRIC BRAKES

