

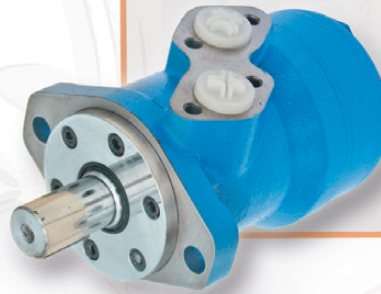

*YMM series*



*YMP series*



*YMR series*

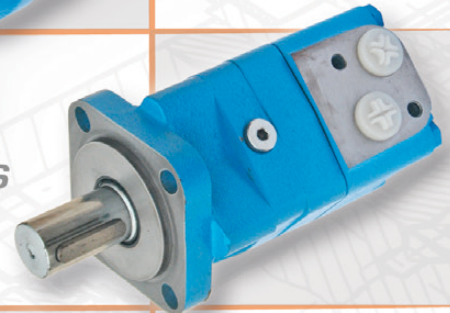

*YMS series*

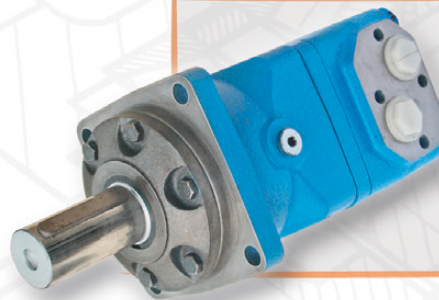

*YMT series*

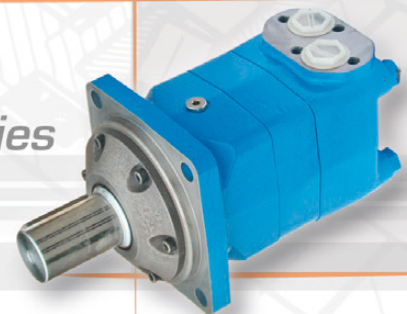

*YMV series*

**ORBITAL MOTORS  
CATALOG**

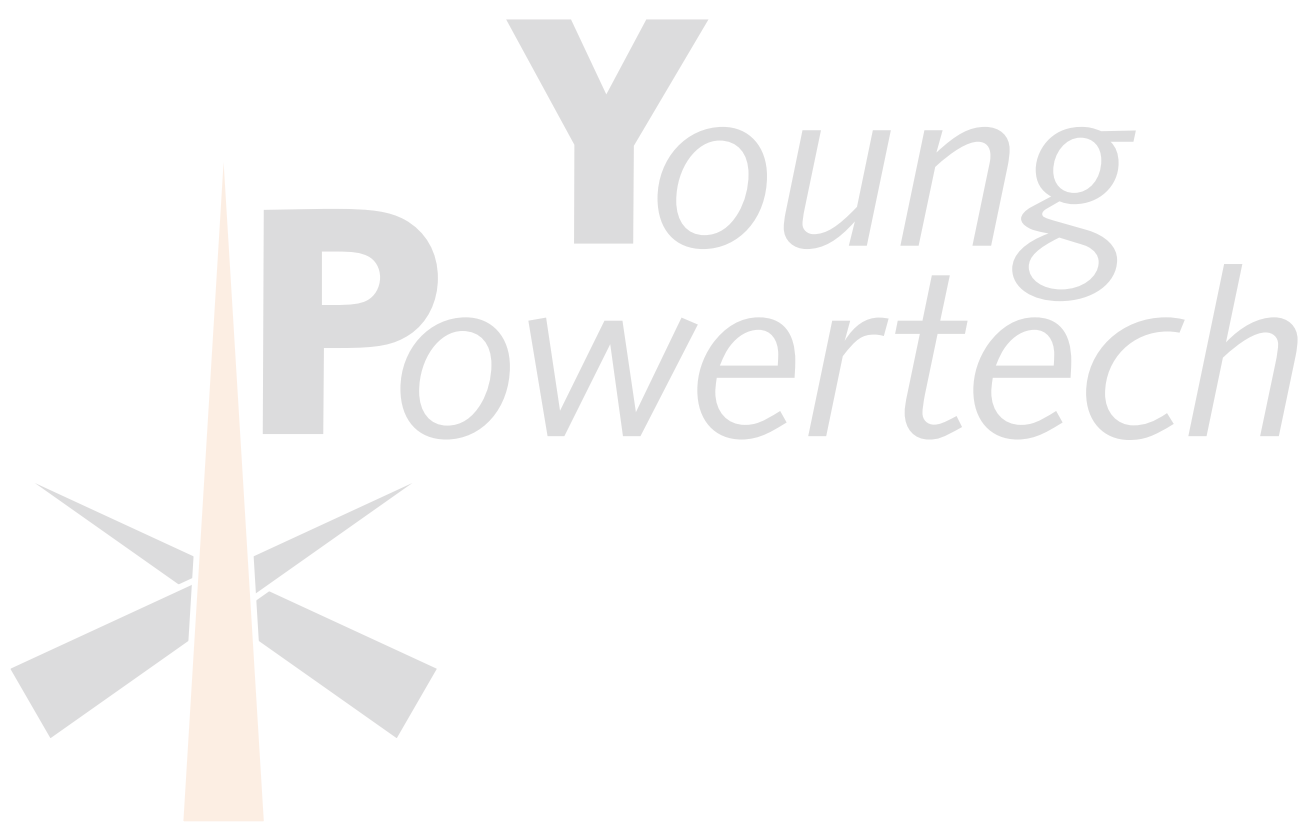

YOUNG POWERTECH INC. RESERVES THE RIGHT  
TO MAKE ALTERATIONS TO ITS  
PRODUCTS AT ANY TIME WITHOUT NOTICE.

YOUNG POWERTECH INC. CANNOT BE  
RESPONSIBLE FOR ANY ERRORS OR  
OMISSIONS IN THIS CATALOG OR ANY  
PRINTED MATERIAL.

# INDEX

SECTION				PAGE
<b>YOUNG</b>	<b>DANFOSS</b>	<b>EATON</b>	<b>M &amp; S</b>	
<b>YMM</b>	OMM	J	MLHM	<b>1</b>
<b>YMP</b>	OMP	-	MLHP	<b>11</b>
<b>YMPH</b>	DH	H	HP	<b>23</b>
<b>YMPW</b>	OMPW	-	MLHPW	<b>31</b>
<b>YMR</b>	OMR	-	MLHR	<b>39</b>
<b>YMRS</b>	DS	S	HR	<b>49</b>
<b>YMH</b>	OMH	-	MLHH	<b>57</b>
<b>YMSY</b>	OMS	2000 ALT	MLHS/MLHSY	<b>67</b>
<b>YMSE</b>	-	2000	-	<b>79</b>
<b>YMSS</b>	OMSS	-	MLHSS	<b>91</b>
<b>YMSJ</b>	-	2000 bearingless	-	<b>99</b>
<b>YMT</b>	OMT	4000-6000 ALT	MLHT	<b>107</b>
<b>YMTE</b>	-	4000-6000	-	<b>117</b>
<b>YMTS</b>	OMTS	-	MLHTS	<b>125</b>
<b>YMTJ</b>	-	4000-6000 bearingless	-	<b>131</b>
<b>YMV/YMVE</b>	OMV	10,000	MLHV	<b>139</b>
<b>YME2</b>	-	-	-	<b>149</b>
<b>YZD</b>	-	-	-	<b>161</b>



# YMM



The **YMM** series motors use the **spool valve** shaft distribution design for simplicity and efficiency. This design integrates the distribution and hydraulic bearing design with the motor shaft.

This motor series uses the “**ROTOR**” gear type manufactured with most advanced technology and quality available to provide high torque and low speed. The gear set of the “rotor” multiplies the output torque without the need of gear reducers that could be required in many applications.

These motors are very compact, economical, powerful, efficient and are designed for medium duty applications.

The large number of displacements, mounting flanges, shafts, valving and other options available for these motors makes them a very flexible unit for many applications.

## SPECIFICATIONS

Distribution Type	Model	Displacement		Max. Operating Pressure		Speed Range Continuous	Max. Output Power	
		in <sup>3</sup> ./rev	.50~3.07	PSI	1450		RPM	HP
Spool Valve Distribution	YMM	cm <sup>3</sup> /rev.	8.2 ~ 375	MPa	10	22~1950	Kw	2.4

## QUICK REFERENCE GUIDE

### YMM SERIES QUICK REFERENCE:

Displacements				
[in <sup>3</sup> /rev]	cm <sup>3</sup> /rev.			
[.50]	8.2	FLOW UP TO	25 LPM	[6.61 GPM]
[.79]	12.9	PRESSURE UP TO	20 MPa	[2900 PSI]
[1.21]	19.9	TORQUE UP TO	100 Nm	[884 In. Lb.]
[1.93]	31.6	SPEED UP TO	2450	RPM
[2.43]	39.8			
[3.05]	50.3			

**Shaft Seals:** Standard high pressure shaft seals permit applications in series or without drain line when required

**Low Speed Valving:** These motors are manufactured following strict procedures to reduce tolerances between all components to permit lower speed, higher efficiency and smoother rotation at very low speeds. These motors are not for high speed or low pressure applications.

**Free Running:** Motors with this option have increased clearances in the rotor set. This allows improved mechanical efficiency, longer life and better performance for high-speed / high-flow applications, winch or similar applications where the motor is cross-ported to allow manual free turning also remay benefit from this option to allow smoother easier free turning of the motor. Last, applications which have many reversals or high pressure spikes can also benefit since the pressure spikes will be reduced by relieving (cross-ported) such spikes internally in the motor. The trade off of these benefits is a slight reduction in volumetric efficiency, particularly at high pressure conditions.

**Special Motors:** These motors have special options like nickel plated shafts or housings for applications in corrosive environments.

### APPLICATION GUIDELINES:

For optimum results the following working conditions are recommended:

- \* Oil temperature should be between 20° - 60° C [68° - 180° F]
- \* Oil filter of 10 - 20 micron
- \* Oil viscosity 42 - 74 mm<sup>2</sup>/s CSA at 40° C
- \* Different shafts are used when there is at start a radial load or not. Check data pages
- \* For longer life we suggest the motor at start up, run for a shorter period of time (one hour) at no more than 30% of rated speed and pressure.

## SPECIFICATION DATA

DISTRIBUTION TYPE		YMM 8	YMM 12.5	YMM 20	YMM 32	YMM 40	YMM 50	
GEOMETRIC DISPLACEMENT	[in <sup>3</sup> ./rev.]	[.50]	[.79]	[1.21]	[1.93]	[2.43]	[3.07]	
	<b>cm<sup>3</sup>/rev.</b>	<b>8.2</b>	<b>12.9</b>	<b>19.9</b>	<b>31.6</b>	<b>39.8</b>	<b>50.3</b>	
MAX. SPEED RPM	CONT.	1950	1550	1000	630	500	400	
	<b>INT.</b>	<b>2450</b>	<b>1940</b>	<b>1250</b>	<b>800</b>	<b>630</b>	<b>500</b>	
MAX. TORQUE [LB. IN.] N*M	CONT.	[LB. IN.]	[97]	[142]	[221]	[354]	[398]	[407]
		<b>N*M</b>	<b>11</b>	<b>16</b>	<b>25</b>	<b>40</b>	<b>45</b>	<b>46</b>
	INT.	[LB. IN.]	[133]	[203]	[310]	[504]	[619]	[778]
		<b>N*M</b>	<b>15</b>	<b>23</b>	<b>35</b>	<b>57</b>	<b>70</b>	<b>88</b>
	PEAK	[LB. IN.]	[186]	[292]	[451]	[566]	[725]	[884]
		<b>N*M</b>	<b>21</b>	<b>33</b>	<b>51</b>	<b>64</b>	<b>82</b>	<b>100</b>
MAX. OUTPUT [HP] KW	CONT.	[HP]	[2.4]	[3.2]	[3.2]	[3.2]	[2.9]	[2.4]
		<b>KW</b>	<b>1.8</b>	<b>2.4</b>	<b>2.4</b>	<b>2.4</b>	<b>2.2</b>	<b>1.8</b>
	INT.	[HP]	[3.4]	[4.3]	[4.3]	[4.3]	[4.3]	[4.3]
		<b>KW</b>	<b>2.6</b>	<b>3.2</b>	<b>3.2</b>	<b>3.2</b>	<b>3.2</b>	<b>3.2</b>
MAX. PRES- SURE DROP [PSI] MPa	CONT.	[PSI]	[1450]	[1450]	[1450]	[1450]	[1305]	[1015]
		<b>MPa</b>	<b>10</b>	<b>10</b>	<b>10</b>	<b>10</b>	<b>9</b>	<b>7</b>
	INT.	[PSI]	[2030]	[2030]	[2030]	[2030]	[2030]	[2030]
		<b>MPa</b>	<b>14</b>	<b>14</b>	<b>14</b>	<b>14</b>	<b>14</b>	<b>14</b>
	PEAK	[PSI]	[2900]	[2900]	[2900]	[2320]	[2320]	[2320]
		<b>MPa</b>	<b>20</b>	<b>20</b>	<b>20</b>	<b>16</b>	<b>16</b>	<b>16</b>
MAX. FLOW [GPM] L/MIN	CONT.	[GPM]	[4.2]	[5.2]	[5.2]	[5.2]	[5.2]	[5.2]
		<b>L/MIN</b>	<b>16</b>	<b>20</b>	<b>20</b>	<b>20</b>	<b>20</b>	<b>20</b>
	INT.	[GPM]	[5.2]	[6.6]	[6.6]	[6.6]	[6.6]	[6.6]
		<b>L/MIN</b>	<b>20</b>	<b>25</b>	<b>25</b>	<b>25</b>	<b>25</b>	<b>25</b>
WEIGHT [LB] KG	[LB]	[4]	[4]	[5]	[5]	[5]	[5]	
	<b>KG</b>	<b>1.9</b>	<b>2</b>	<b>2.1</b>	<b>2.2</b>	<b>2.3</b>	<b>2.4</b>	

\* Continuous pressure:

\* Intermittent pressure:

\* Peak pressure:

Max. value of operating motor continuously.

Max. value of operating motor in 6 seconds per minute.

Max. value of operating motor in 0.6 second per minute.

## PERFORMANCE DATA

YMM 8 [0.50 in<sup>3</sup>/rev] 8.2 cm<sup>3</sup>/rev. Max cont. Max int.

	[507]	[725]	[1015]	[1450]	[1740]	[2030]	[PSI]
	3.5	5	7	10	12	14	MPa
GPM	[0.53]	[27]	[44]	[71]	[88]	[106]	[124]
L/min	2	3	5	8	10	12	14
Flow (L/min)	[1.1]	[27]	[44]	[62]	[97]	[115]	[133]
	4	474	471	463	426	391	331
Flow (L/min)	[2.1]	[27]	[44]	[62]	[97]	[115]	[133]
	8	953	946	926	884	855	816
Flow (L/min)	[3.2]	[18]	[44]	[62]	[88]	[115]	[133]
	12	1444	1426	1402	1360	1324	1288
Max cont.	[3.9]		[35]	[62]	[88]	[106]	[124]
	15		1912	1900	1861	1833	1780
Max int.	[5.3]		[0.00]	[53]	[88]	[97]	[124]
	20		2432	2395	2350	2328	2281

TORQUE [LB-IN]  
TORQUE (N•M)  
SPEED (RPM)

Max cont.  
Max int.

YMM 12.5 [0.79 in<sup>3</sup>/rev] 12.9 cm<sup>3</sup>/rev. Max cont. Max int.

	[507]	[725]	[1015]	[1450]	[1740]	[2030]	[PSI]
	3.5	5	7	10	12	14	MPa
GPM	[0.53]	[53]	[71]	[97]	[142]	[168]	
L/min	2	6	8	11	16	19	
Flow (L/min)	[1.1]	[53]	[71]	[106]	[150]	[168]	[203]
	4	296	289	274	229	200	145
Flow (L/min)	[2.1]	[44]	[71]	[106]	[150]	[177]	[212]
	8	605	596	583	543	514	469
Flow (L/min)	[3.2]	[44]	[71]	[97]	[141]	[177]	[212]
	12	912	905	895	859	834	784
Max cont.	[3.9]	[44]	[62]	[389]	[407]	[168]	[203]
	15	1152	1144	1136	1102	1078	1036
Max int.	[5.3]	[27]	[62]	[88]	[133]	[168]	[195]
	20	1542	1532	1521	1500	1482	1437
Max int.	[6.6]	[18]	[53]	[80]	[124]	[159]	[195]
	25	1910	1891	1878	1848	1828	1788

TORQUE [LB-IN]  
TORQUE (N•M)  
SPEED (RPM)

Max cont.  
Max int.

YMM 20 [1.21 in<sup>3</sup>/rev] 19.9 cm<sup>3</sup>/rev. Max cont. Max int.

	[246]	[507]	[725]	[1015]	[1450]	[1740]	[2030]	[PSI]
	1.7	3.5	5	7	10	12	14	MPa
GPM	[0.53]	[27]	[80]	[124]	[168]	[230]	[265]	
L/min	2	3	9	14	19	26	30	
Flow (L/min)	[1.1]	[35]	[80]	[124]	[168]	[230]	[274]	[318]
	4	197	191	182	178	134	112	74
Flow (L/min)	[2.1]	[35]	[80]	[115]	[168]	[239]	[274]	[318]
	8	398	395	391	377	340	319	288
Flow (L/min)	[3.2]	[27]	[71]	[115]	[159]	[230]	[274]	[327]
	12	596	594	588	579	545	523	493
Max cont.	[3.9]	[27]	[71]	[106]	[150]	[221]	[265]	[318]
	15	745	741	738	728	695	684	660
Max int.	[5.3]	[9]	[53]	[97]	[168]	[212]	[256]	[310]
	20	998	995	991	985	962	916	885
Max int.	[6.6]		[35]	[80]	[124]	[203]	[248]	[292]
	25		1247	1245	1242	1189	1180	1176

TORQUE [LB-IN]  
TORQUE (N•M)  
SPEED (RPM)

Max cont.  
Max int.

YMM 32 [1.93 in<sup>3</sup>/rev] 31.6 cm<sup>3</sup>/rev. Max cont. Max int.

	[246]	[507]	[725]	[1015]	[1450]	[1740]	[2030]	[PSI]
	2	3.5	5	7	10	12	14	MPa
GPM	[0.53]	[62]	[133]	[186]	[248]	[354]		
L/min	2	7	15	21	28	40		
Flow (L/min)	[1.1]	[62]	[133]	[186]	[256]	[363]	[424]	[504]
	4	126	121	114	106	82	67	49
Flow (L/min)	[2.1]	[62]	[133]	[186]	[256]	[363]	[433]	[513]
	8	250	244	239	231	207	194	167
Flow (L/min)	[3.2]	[53]	[115]	[177]	[248]	[354]	[424]	[513]
	12	378	374	369	362	338	322	297
Max cont.	[3.9]	[35]	[106]	[159]	[239]	[345]	[415]	[504]
	15	476	472	468	462	441	429	406
Max int.	[5.3]	[27]	[88]	[150]	[221]	[327]	[407]	[486]
	20	633	630	627	619	601	585	566
Max int.	[6.6]	[9]	[70]	[133]	[203]	[309]	[380]	[460]
	25	791	789	787	783	766	753	732

TORQUE [LB-IN]  
TORQUE (N•M)  
SPEED (RPM)

Max cont.  
Max int.



## PERFORMANCE DATA

YMM 40 [2.43 in<sup>3</sup>/rev] 39.8 cm<sup>3</sup>/rev.

Max cont.

Max int.

	[435] 3	[725] 5	[1015] 7	[1232] 9	[1450] 10	[1740] 12	[PSI] MPa
GPM	[0.53]	[142]	[239]	[318]	[389]	[451]	
L/min	2	16	27	36	44	51	
		<b>45</b>	<b>40</b>	<b>34</b>	<b>28</b>	<b>17</b>	
	[1.1]	[142]	[239]	[327]	[389]	[460]	[548]
	4	16	27	37	44	52	62
		<b>96</b>	<b>93</b>	<b>85</b>	<b>79</b>	<b>65</b>	<b>52</b>
	[2.1]	[133]	[230]	[319]	[389]	[460]	[557]
	8	15	26	36	44	52	63
		<b>197</b>	<b>195</b>	<b>182</b>	<b>176</b>	<b>166</b>	<b>154</b>
	[3.2]	[124]	[221]	[310]	[380]	[451]	[548]
	12	14	25	35	43	51	62
		<b>293</b>	<b>287</b>	<b>282</b>	<b>277</b>	<b>268</b>	<b>257</b>
	[3.9]	[115]	[212]	[301]	[371]	[442]	[548]
	15	13	24	34	42	50	62
		<b>371</b>	<b>365</b>	<b>360</b>	<b>355</b>	<b>347</b>	<b>338</b>
	[5.3]	[88]	[186]	[274]	[345]	[425]	[522]
	20	10	21	31	39	48	59
		<b>497</b>	<b>492</b>	<b>487</b>	<b>480</b>	<b>472</b>	<b>463</b>
	[6.6]	[62]	[168]	[256]	[327]	[389]	[495]
	25	7	19	29	37	44	56
		<b>622</b>	<b>617</b>	<b>612</b>	<b>607</b>	<b>600</b>	<b>591</b>

Max cont.

Max int.

YMM 50 [3.07 in<sup>3</sup>/rev] 50.3 cm<sup>3</sup>/rev.

Max cont.

Max int.

	[217] 1.5	[435] 3	[725] 5	[1015] 7	[1450] 10	[PSI] MPa
GPM	[0.53]	[97]	[203]	[318]	[442]	
L/min	2	11	23	36	50	
		<b>37</b>	<b>33</b>	<b>27</b>	<b>22</b>	
	[1.1]	[97]	[195]	[318]	[442]	[619]
	4	11	22	36	50	70
		<b>76</b>	<b>73</b>	<b>68</b>	<b>63</b>	<b>55</b>
	[2.1]	[97]	[186]	[310]	[442]	[628]
	8	11	21	35	50	71
		<b>157</b>	<b>154</b>	<b>149</b>	<b>145</b>	<b>137</b>
	[3.2]	[97]	[177]	[292]	[433]	[628]
	12	11	20	33	49	71
		<b>237</b>	<b>234</b>	<b>231</b>	<b>226</b>	<b>218</b>
	[3.9]	[88]	[159]	[283]	[416]	[610]
	15	10	18	32	47	69
		<b>296</b>	<b>295</b>	<b>294</b>	<b>288</b>	<b>282</b>
	[5.3]	[71]	[124]	[256]	[389]	[566]
	20	8	14	29	44	64
		<b>395</b>	<b>395</b>	<b>393</b>	<b>390</b>	<b>381</b>
	[6.6]	[35]	[88]	[221]	[354]	[522]
	25	4	10	25	40	59
		<b>498</b>	<b>496</b>	<b>494</b>	<b>490</b>	<b>484</b>

Max cont.

Max int.

## YMM END PORT DIMENSIONS AND MOUNTING DATA

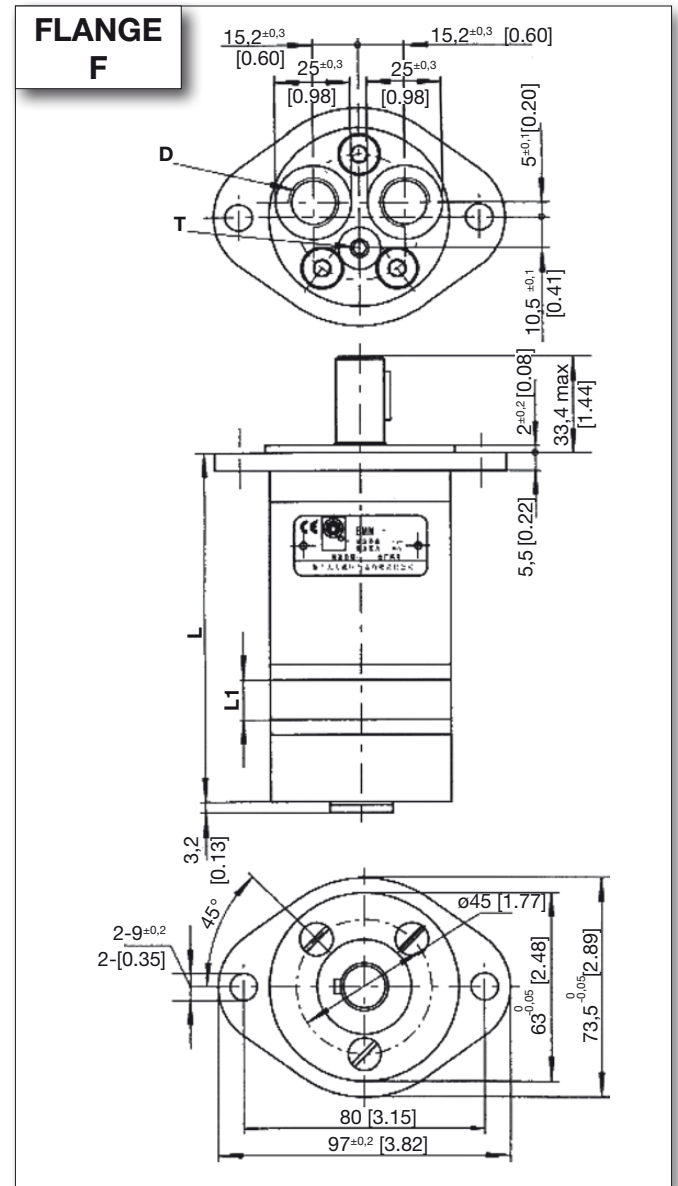
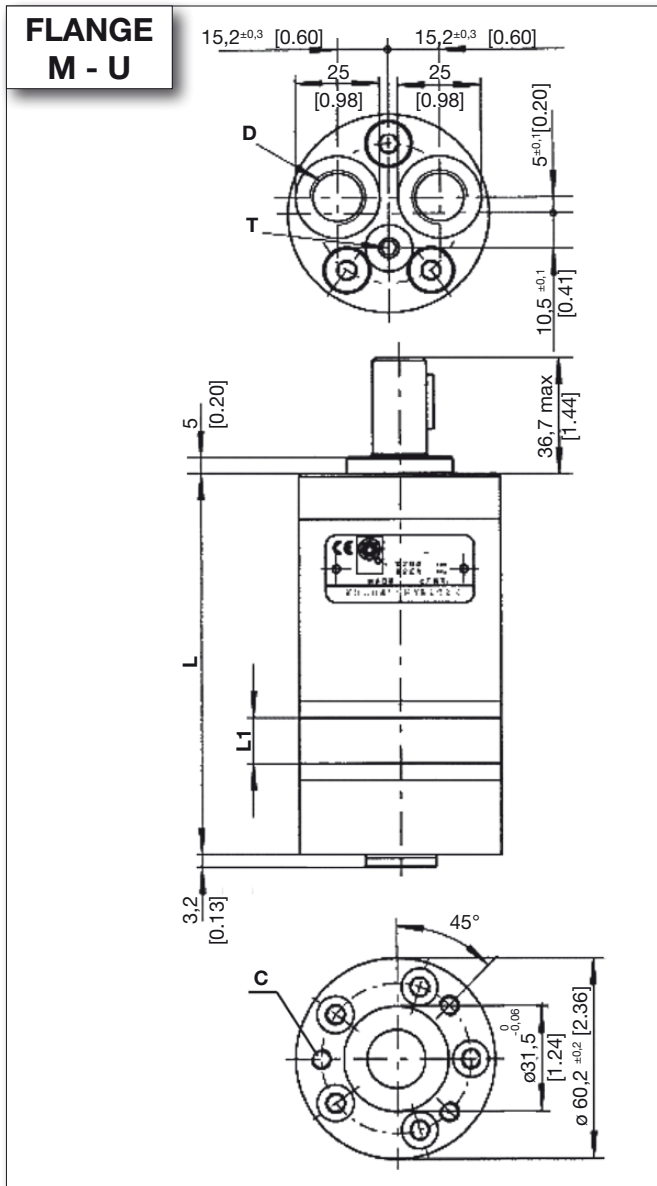

MODEL	M, U				F			
	[INCHES]		MM		[INCHES]		MM	
	L	L1	L	L1	L	L1	L	L1
YMM 8	[4.09]	[.14]	104	3.5	[4.21]	[.14]	107	3.5
YMM 12.5	[4.17]	[.22]	106	5.5	[4.29]	[.22]	109	5.5
YMM 20	[4.29]	[.33]	109	8.5	[4.41]	[.33]	112	8.5
YMM 32	[4.49]	[.53]	114	13.5	[4.61]	[.53]	117	13.5
YMM 40	[4.65]	[.67]	118	17	[4.65]	[.67]	118	17
YMM 50	[4.80]	[.85]	122	21.5	[4.92]	[.85]	125	21.5

MOUNTING CODE	M, U				F				
	ORDERING CODE	IE	DEPTH	IU	DEPTH	IE	DEPTH	IU	DEPTH
C		M6	10 MM	1/4-28UNF-2B	10 MM				
D		G 3/8	12 MM	9/16-18 UNF	12 MM	G 3/8	12 MM	9/16-18UNF	12 MM
T		G 1/8	8 MM	3/8-24 UNF	8 MM	G 1/8	8 MM	3/8-24UNF	8 MM

## YMM SIDE PORT DIMENSIONS AND MOUNTING DATA

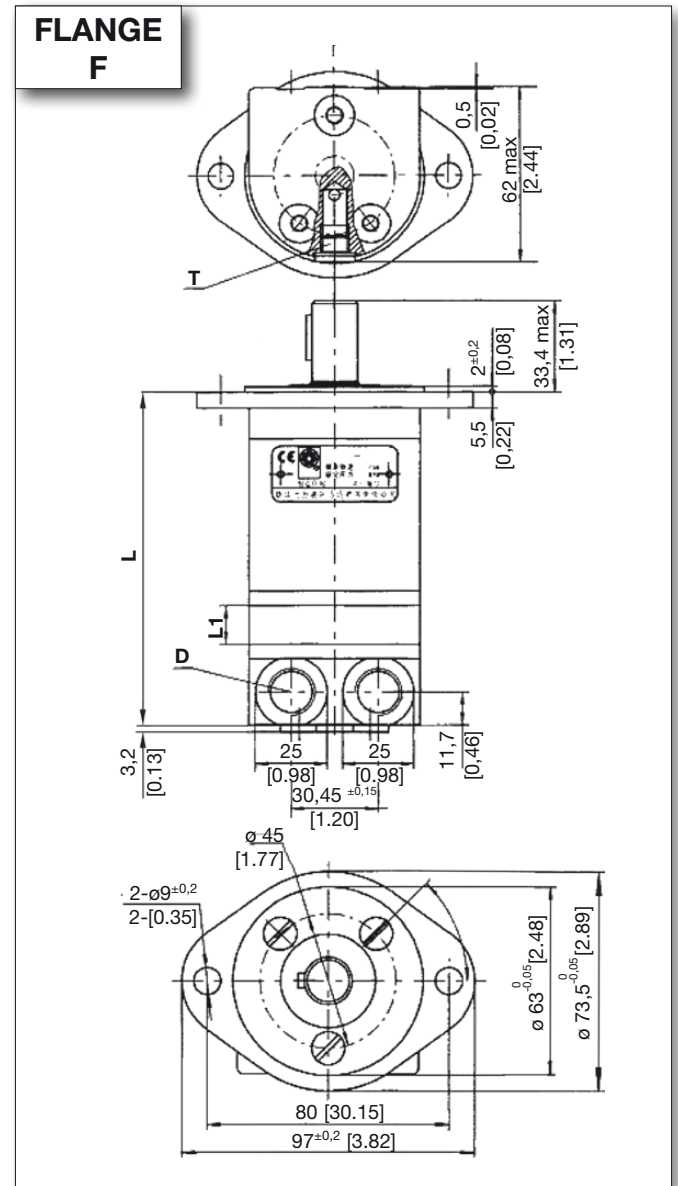
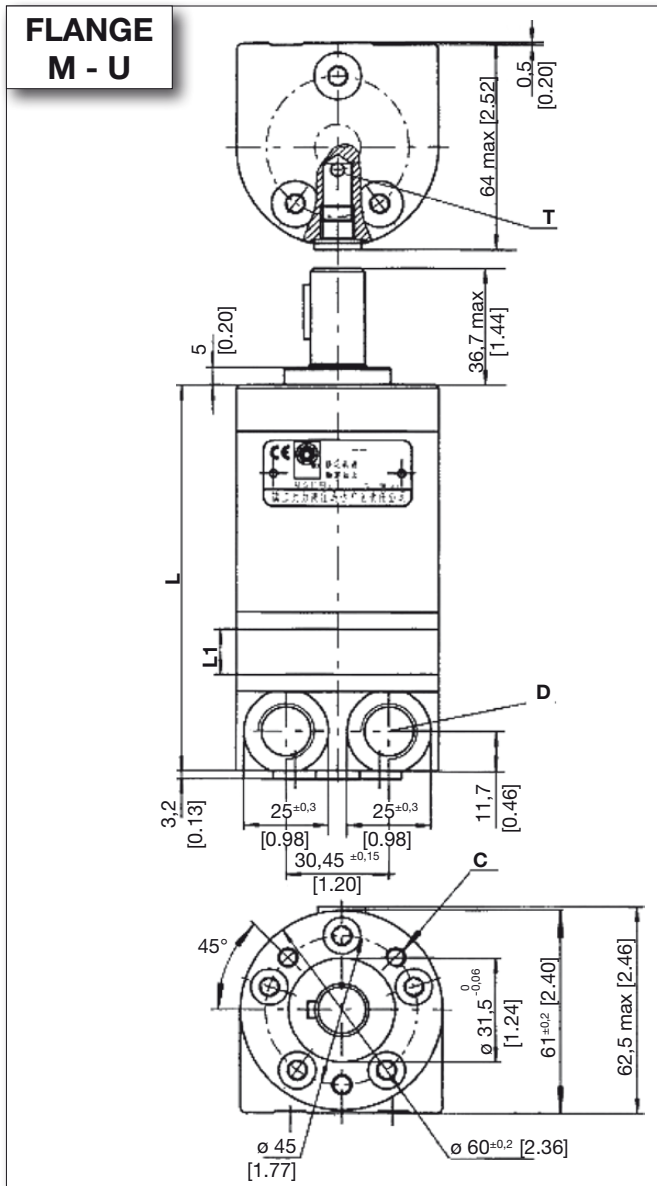

MODEL	M, U				F			
	[INCHES]		MM		[INCHES]		MM	
	L	L1	L	L1	L	L1	L	L1
YMM 8	[4.13]	[.14]	105	3.5	[4.29]	[.14]	109	3.5
YMM 12.5	[4.21]	[.22]	107	5.5	[4.37]	[.22]	111	5.5
YMM 20	[4.33]	[.33]	110	8.5	[4.49]	[.33]	114	8.5
YMM 32	[4.53]	[.53]	115	13.5	[4.69]	[.53]	119	13.5
YMM 40	[4.65]	[.67]	118	17	[4.65]	[.67]	118	17
YMM 50	[4.84]	[.85]	123	21.5	[5.00]	[.85]	127	21.5

MOUNTING CODE	M, U				F				
	ORDERING CODE	E	DEPTH	U	DEPTH	E	DEPTH	U	DEPTH
C	M6	10 mm	1/4-28UNF-2B	10 mm					
D	G 3/8	12 mm	9/16-18 UNF	12 mm	G 3/8	12 mm	9/16-18UNF	12 mm	
T	G 1/8	8 mm	3/8-24 UNF	8 mm	G 1/8	8 mm	3/8-24UNF	8 mm	

## MOTOR SHAFT EXTENSIONS

**A**

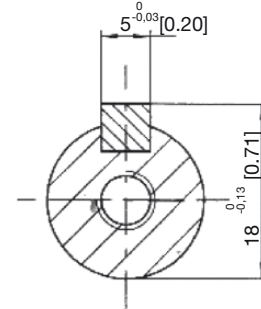
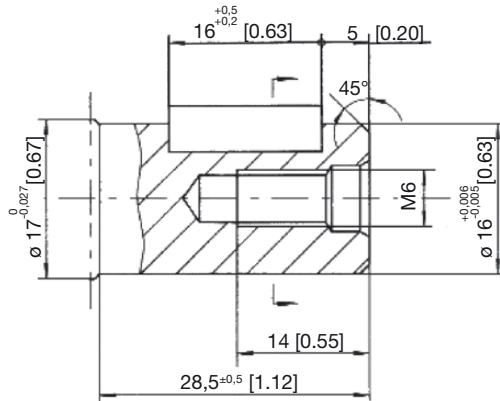

Shaft A: 16 mm Keyed  
Parallel key 5x5x16

**B**

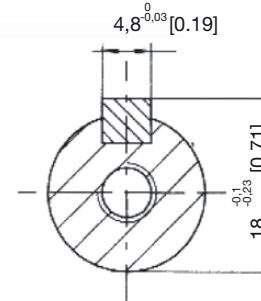
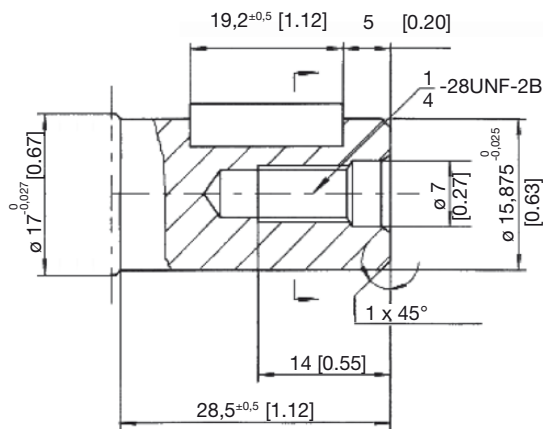

Shaft B: 15.875 mm Keyed  
Parallel key 4.8x4.8x19.35

**C**

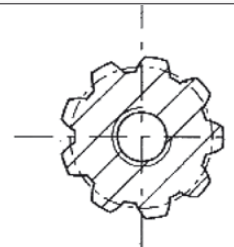
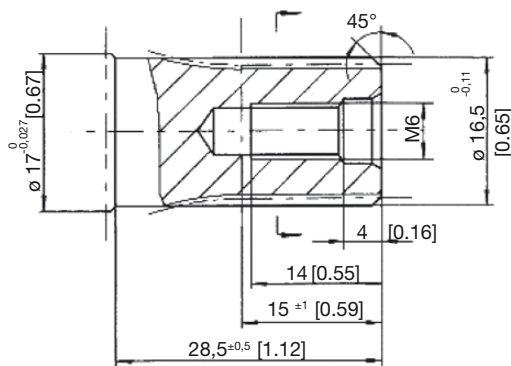

Shaft C: Involute splined shaft  
B17x14 DIN5482

**H**

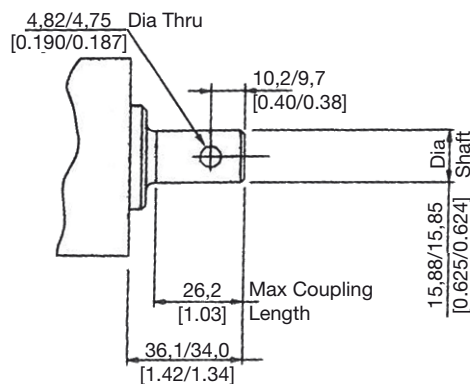

Shaft H: 15.815 ø Straight  
w/cross hole shaft

## ADDITIONAL INFORMATION

### PERMISSIBLE SHAFT SEAL PRESSURE

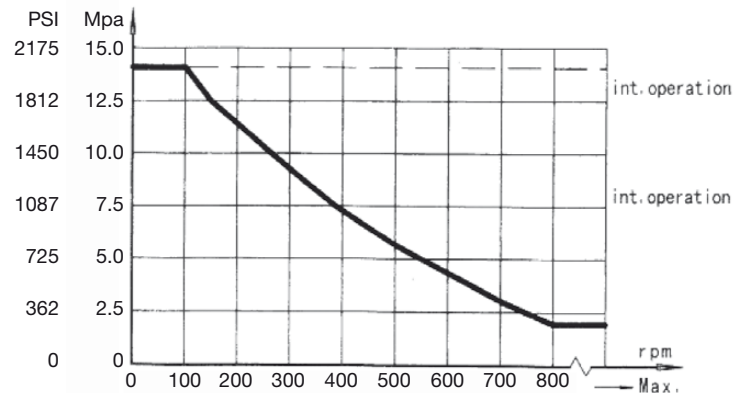
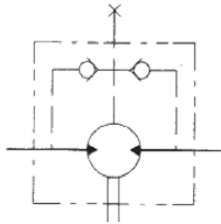

IN APPLICATIONS WITHOUT A DRAIN LINE, THE PRESSURE EXERTED ON THE SHAFT SEAL WILL EXCEED THE PRESSURE IN THE RETURN LINE. APPLICATIONS USING A DRAIN LINE, THE PRESSURE ON THE OUTPUT SHAFT SEAL CAN EQUAL THE PRESSURE IN THE DRAIN LINE.

### SHAFT ROTATION DIRECTION

When viewing the motor from the output shaft end, port A is defined to be on the right and port B is defined to be on the left side. Standard rotation motors rotate CW when port A is pressurized. The motors are bi-directional and CCW rotation occurs when port B is pressurized.

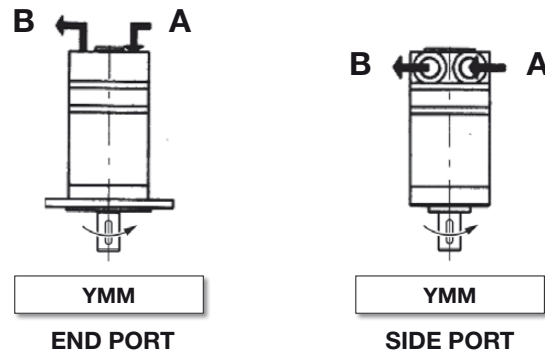

Reverse rotation motors can special ordered which will operate with opposite rotation outlined above.

### PERMISSIBLE SHAFT LOAD

$$F_r = \frac{130400}{61.5 + L} \text{ N}$$

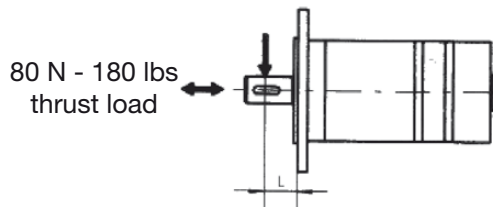

$F_r$  = Radial Force (N)  
 $L$  = Distance (mm)  
 $n$  = Speed (rpm)  
 Rhomb-flange  $L=15\text{mm}$   
 Square-flange  $L=20\text{mm}$

Allowed side load (Axial) is 1600 N [ 360 lbf ] when  $L = 20 \text{ mm}$  [ 0.79 in ]

## ORDERING INFORMATION

	1	2	3	4	5	6	7
YMM							

1	2		3		4		5		6		7	
DISP.	FLANGE		OUTPUT SHAFT		PORT AND DRAIN PORT		ROTATION DIRECTION		PAINT		SPECIAL OPTIONS	
8	M	3-M6 Round Flange Pilot Ø 31.5X5	A	Shaft Ø 16, Parallel Key 5x5x16	E	Side Port G 3/8, G 1/8	NONE	STANDARD	00	NO PAINT	NONE	STANDARD
12.5	U	3-1/4-28 UNF Round Flange Pilot Ø 31.5X5	B	Shaft Ø 15.875, Parallel Key 4.8x4.8x19.35	U	Side Port 9/16-18 UNF, 3/8-24 UNF	R	OPPOSITE			FR	FREE RUNNING
16	F	2- Ø 9 Rhomb- Flange, Pilot Ø 63x2	C	Shaft Ø 16.5 Splined Involute B17x14 Din5482	IE	End Port Back Port G 3/8, G 1/8			B	BLACK STANDARD		
20			H	Shaft 4.75 ø Straight w/cross hole 4.82/4.25 (.1901/.187)	IU	End Port Back Port 9/16-18 UNF, 3/8-24 UNF						
32											CRS	CORROSION RESISTANT SHAFT
40												
50											HTS	HIGH TEMP SEAL

### ORDERING CODE:

All options have been determined with letters, numbers or combinations. All boxes must be filled with proper codes. If specification is not in the table, please contact us with your requirements.

# YMP



The **YMP** series motors use the spool valve shaft distribution design for simplicity and efficiency. This design integrates the distribution and hydraulic bearing design with the motor shaft.

This motor series uses the “**ROTOR**” gear type manufactured with most advanced technology and quality available to provide high torque and low speed. The gear set of the “rotor” multiplies the output torque without the need of gear reducers that could be required in many applications.

These motors are very compact, economical, powerful, efficient and are designed for medium duty applications.

The large number of displacements, mounting flanges, shafts, valving and other options available for these motors makes them a very flexible unit for many applications.

The inlet and outlet ports (A & B) are parallel with the mounting flange to meet certain application requirements. The SAE flange is available for these ports.

## SPECIFICATIONS

Distribution Type	Model	Displacement		Max. Operating Pressure		Speed Range Continuous	Max. Output Power	
		[in <sup>3</sup> ./rev]	[2.18~24.41]	[PSI]	[2400]		[HP]	[12]
Spool Valve Distribution	YMP	cm <sup>3</sup> /rev.	36 ~ 400	MPA	16.5	30~1078	Kw	9

## QUICK REFERENCE GUIDE

### YMP SERIES QUICK REFERENCE:

Displacements				
[in <sup>3</sup> /rev]	cm <sup>3</sup> /rev.			
[2.18]	36			
[3.15]	51.7	FLOW UP TO	75 LPM	[20 GPM]
[4.74]	77.7	PRESSURE UP TO	16.5 MPa	[2392 PSI]
[5.87]	96.2	TORQUE UP TO	533 Nm	[4847 Lb.In.]
[7.19]	117.9	SPEED UP TO	975 RPM	
[9.49]	155.5			
[11.59]	189.9			
[14.10]	231			
[19.00]	311.7			
[23.57]	386.2			

**Shaft Seals:** Standard high pressure shaft seals permit applications in series or without drain line when required

**Low Speed Valving:** These motors are manufactured following strict procedures to reduce tolerances between all components to permit lower speed, higher efficiency and smoother rotation at very low speeds. These motors are not for high speed or low pressure applications.

**Free Running:** Motors with this option have increased clearances in the rotor set. This allows improved mechanical efficiency, longer life and better performance for high-speed / high-flow applications, winch or similar applications where the motor is cross-ported to allow manual free turning also remain benefit from this option to allow smoother easier free turning of the motor. Last, applications which have many reversals or high pressure spikes can also benefit since the pressure spikes will be reduced by relieving (cross-porting) such spikes internally in the motor. The trade off of these benefits is a slight reduction in volumetric efficiency, particularly at high pressure conditions.

**Special Motors:** These motors have special options like nickel plated shafts or housings for applications in corrosive environments.

### APPLICATION GUIDELINES:

For optimum results the following working conditions are recommended:

- \* Oil temperature should be between 20° - 60° C [68° - 180° F]
- \* Oil filter of 10 - 20 micron
- \* Oil viscosity 42 - 74 mm<sup>2</sup>/s CSA at 40° C
- \* Different shafts are used when there is a radial load or not. Check data pages
- \* For longer life we suggest the motor at start up, run for a shorter period of time (one hour) at no more than 30% of rated speed and pressure.



## SPECIFICATION DATA

DISTRIBUTION TYPE		YMP 36	YMP 50	YMP 80	YMP 100	YMP 125	YMP 160	YMP 200	YMP 250	YMP 315	YMP 400	
GEOMETRIC DISPLACEMENT	[in <sup>3</sup> ./rev.]	[2.20]	[3.15]	[4.74]	[5.87]	[7.19]	[9.49]	[11.59]	[14.10]	[19.01]	[23.57]	
	cm <sup>3</sup> /rev.	36	51.7	77.7	96.2	117.9	155.5	189.9	231	311.7	386.2	
MAX. SPEED RPM	CONT.	1078	879	740	589	475	370	296	237	189	149	
	INT.	<b>1210</b>	<b>975</b>	<b>827</b>	<b>673</b>	<b>594</b>	<b>463</b>	<b>370</b>	<b>297</b>	<b>236</b>	<b>185</b>	
MAX. TORQUE [LB. IN.] N*M	CONT.	[LB. IN.]	[486]	[716]	[1141]	[1423]	[1786]	[2167]	[2529]	[3184]	[3591]	[4847]
		N*M	<b>55</b>	<b>81</b>	<b>129</b>	<b>161</b>	<b>202</b>	<b>245</b>	<b>286</b>	<b>360</b>	<b>406</b>	<b>435</b>
	INT.	[LB. IN.]	[672]	[955]	[1512]	[1884]	[2370]	[3025]	[3449]	[4033]	[4466]	[4714]
		N*M	<b>76</b>	<b>108</b>	<b>171</b>	<b>213</b>	<b>268</b>	<b>342</b>	<b>390</b>	<b>456</b>	<b>505</b>	<b>533</b>
MAX. OUTPUT [HP] KW	CONT.	[HP]	[8]	[9]	[12]	[12]	[12]	[11]	[11]	[10]	[10]	
		KW	<b>6</b>	<b>7</b>	<b>9.1</b>	<b>9</b>	<b>9.1</b>	<b>8.7</b>	<b>8.1</b>	<b>8.2</b>	<b>7.2</b>	<b>6.1</b>
	INT.	[HP]	[10]	[12]	[16]	[16]	[16]	[16]	[15]	[14]	[12]	[10]
		KW	<b>8</b>	<b>8.9</b>	<b>11.8</b>	<b>11.9</b>	<b>11.8</b>	<b>11.9</b>	<b>10.9</b>	<b>10.1</b>	<b>8.6</b>	<b>7.2</b>
MAX. PRES- SURE DROP [PSI] MP <sub>A</sub>	CONT.	[PSI]	[1812]	[1812]	[1812]	[1812]	[1812]	[1812]	[1595]	[1595]	[1595]	[1450]
		MP <sub>A</sub>	<b>12.5</b>	<b>12.5</b>	<b>12.5</b>	<b>12.5</b>	<b>12.5</b>	<b>12.5</b>	<b>11</b>	<b>11</b>	<b>11</b>	<b>10</b>
	INT.	[PSI]	[2392]	[2392]	[2392]	[2392]	[2392]	[2392]	[2392]	[2030]	[1812]	[1522]
		MP <sub>A</sub>	<b>16.5</b>	<b>16.5</b>	<b>16.5</b>	<b>16.5</b>	<b>16.5</b>	<b>16.5</b>	<b>16.5</b>	<b>14</b>	<b>12.5</b>	<b>10.5</b>
	PEAK	[PSI]	[2392]	[2392]	[2392]	[2392]	[2392]	[2392]	[2392]	[2030]	[1812]	[1522]
		MP <sub>A</sub>	<b>16.5</b>	<b>16.5</b>	<b>16.5</b>	<b>16.5</b>	<b>16.5</b>	<b>16.5</b>	<b>16.5</b>	<b>14</b>	<b>12.5</b>	<b>10.5</b>
MAX. FLOW [GPM] L/MIN	CONT.	[GPM]	[10.4]	[11.8]	[15.8]	[15.8]	[15.8]	[15.8]	[15.8]	[15.8]	[15.8]	[15.8]
		L/MIN	<b>40</b>	<b>45</b>	<b>60</b>	<b>60</b>	<b>60</b>	<b>60</b>	<b>60</b>	<b>60</b>	<b>60</b>	<b>60</b>
	INT.	[GPM]	[11.8]	[13.2]	[19.8]	[19.8]	[19.8]	[19.8]	[19.8]	[19.8]	[19.8]	[19.8]
		L/MIN	<b>45</b>	<b>50</b>	<b>75</b>	<b>75</b>	<b>75</b>	<b>75</b>	<b>75</b>	<b>75</b>	<b>75</b>	<b>75</b>
WEIGHT [LB] KG	[LB]	[12]	[12]	[13]	[13]	[13]	[14]	[14]	[15]	[15]	[16]	
	KG	<b>5.6</b>	<b>5.6</b>	<b>5.7</b>	<b>5.9</b>	<b>6</b>	<b>6.2</b>	<b>6.4</b>	<b>6.6</b>	<b>6.9</b>	<b>7.4</b>	

- \* Continuous pressure: Max. value of operating motor continuously.
- \* Intermittent pressure: Max. value of operating motor in 6 seconds per minute.
- \* Peak pressure: Max. value of operating motor in 0.6 second per minute.

## PERFORMANCE DATA

YMP 36 [2.19 in<sup>3</sup>/rev] 36 cm<sup>3</sup>/rev.

		[435]	[870]	[1015]	[1160]	[1450]	[1595]	[1813]	[2493]	[PSI]
		3	6	7	8	10	11	12	16.5	MPa
GPM	[2.1]	[115]	[212]	[256]	[301]	[380]	[424]	[486]	[654]	
	L/min	13	24	29	34	43	48	55	74	
L/min	8	<b>214</b>	<b>205</b>	<b>200</b>	<b>194</b>	<b>187</b>	<b>179</b>	<b>168</b>	<b>138</b>	
	[4.0]	[115]	[221]	[256]	[301]	[380]	[424]	[495]	[663]	TORQUE (LB-IN)
L/min	15	13	25	29	34	43	48	56	75	TORQUE (N•M)
		<b>406</b>	<b>398</b>	<b>391</b>	<b>383</b>	<b>374</b>	<b>353</b>	<b>353</b>	<b>324</b>	SPEED (RPM)
Flow (L/min)	[5.3]	[115]	[212]	[256]	[301]	[380]	[424]	[495]	[627]	
	L/min	13	24	29	34	43	48	56	76	
L/min	20	<b>541</b>	<b>534</b>	<b>528</b>	<b>521</b>	<b>513</b>	<b>500</b>	<b>486</b>	<b>458</b>	
	[7.9]	[106]	[212]	[256]	[301]	[380]	[424]	[495]	[672]	
L/min	30	12	24	29	34	43	48	56	76	
		<b>814</b>	<b>804</b>	<b>792</b>	<b>778</b>	<b>763</b>	<b>749</b>	<b>726</b>	<b>701</b>	
Flow (L/min)	[9.2]	[106]	[203]	[248]	[301]	[380]	[424]	[495]	[672]	
	L/min	12	23	28	34	43	48	56	76	
L/min	35	<b>952</b>	<b>944</b>	<b>930</b>	<b>913</b>	<b>897</b>	<b>879</b>	<b>858</b>	<b>833</b>	
	[11.9]	[106]	[203]	[248]	[283]	[362]	[415]	[486]	[663]	
Max cont.	45	12	23	28	32	41	47	55	75	Max cont.
		<b>1090</b>	<b>1078</b>	<b>1064</b>	<b>1048</b>	<b>1024</b>	<b>998</b>	<b>977</b>	<b>943</b>	
Max int.	[13.2]	[97]	[194]	[230]	[283]	[362]	[407]	[477]	[654]	
	50	11	22	26	32	41	46	54	74	Max int.
		<b>1232</b>	<b>1218</b>	<b>1196</b>	<b>1175</b>	<b>1149</b>	<b>1118</b>	<b>1080</b>	<b>1044</b>	

YMP 50 [3.15 in<sup>3</sup>/rev] 51.7 cm<sup>3</sup>/rev.

		[435]	[870]	[1015]	[1160]	[1450]	[1595]	[1813]	[2393]	[PSI]
		3	6	7	8	10	11	12	16	MPa
GPM	[2.1]	[150]	[336]	[389]	[442]	[557]	[619]	[699]	[920]	
	L/min	17	38	44	50	63	70	79	104	
L/min	8	<b>154</b>	<b>149</b>	<b>144</b>	<b>141</b>	<b>135</b>	<b>129</b>	<b>123</b>	<b>92</b>	
	[4.0]	[168]	[336]	[389]	[442]	[566]	[628]	[708]	[929]	TORQUE (LB-IN)
L/min	15	19	38	44	50	64	71	80	105	TORQUE (N•M)
		<b>292</b>	<b>286</b>	<b>238</b>	<b>277</b>	<b>273</b>	<b>267</b>	<b>262</b>	<b>231</b>	SPEED (RPM)
Flow (L/min)	[5.3]	[150]	[336]	[389]	[451]	[566]	[628]	[708]	[946]	
	L/min	17	38	44	51	64	71	80	107	
L/min	20	<b>390</b>	<b>385</b>	<b>382</b>	<b>376</b>	<b>374</b>	<b>367</b>	<b>360</b>	<b>332</b>	
	[7.9]	[142]	[327]	[389]	[442]	[566]	[628]	[716]	[955]	
L/min	30	16	37	44	50	64	71	81	108	
		<b>586</b>	<b>579</b>	<b>572</b>	<b>568</b>	<b>562</b>	<b>556</b>	<b>546</b>	<b>516</b>	
Flow (L/min)	[9.2]	[133]	[318]	[380]	[442]	[557]	[628]	[708]	[946]	
	L/min	15	36	43	50	63	71	80	107	
L/min	35	<b>683</b>	<b>675</b>	<b>670</b>	<b>663</b>	<b>656</b>	<b>647</b>	<b>641</b>	<b>614</b>	
	[11.9]	[124]	[301]	[371]	[433]	[557]	[619]	[708]	[946]	
Max cont.	45	14	34	42	49	63	70	80	107	Max cont.
		<b>879</b>	<b>868</b>	<b>862</b>	<b>855</b>	<b>849</b>	<b>840</b>	<b>833</b>	<b>799</b>	
Max int.	[13.2]	[115]	[292]	[363]	[425]	[548]	[601]	[699]		
	50	13	33	41	48	62	68	79		Max int.
		<b>975</b>	<b>962</b>	<b>955</b>	<b>949</b>	<b>943</b>	<b>937</b>	<b>927</b>		

YMP 80 [4.74 in<sup>3</sup>/rev] 77.7 cm<sup>3</sup>/rev.

		[435]	[870]	[1015]	[1160]	[1450]	[1595]	[1814]	[2394]	[PSI]
		3	6	7	8	10	11	12	16	MPa
GPM	[2.1]	[256]	[531]	[619]	[708]	[893]	[982]	[1132]	[1486]	
	L/min	29	60	70	80	101	111	128	168	
L/min	8	<b>97</b>	<b>94</b>	<b>91</b>	<b>88</b>	<b>84</b>	<b>79</b>	<b>74</b>	<b>50</b>	
	[4.0]	[256]	[539]	[628]	[716]	[893]	[1008]	[1141]	[1503]	TORQUE (LB-IN)
L/min	15	29	61	71	81	101	114	129	170	TORQUE (N•M)
		<b>184</b>	<b>181</b>	<b>178</b>	<b>175</b>	<b>171</b>	<b>167</b>	<b>162</b>	<b>140</b>	SPEED (RPM)
Flow (L/min)	[5.3]	[248]	[531]	[628]	[716]	[893]	[931]	[1141]	[1503]	
	L/min	28	60	71	81	101	112	129	170	
L/min	20	<b>247</b>	<b>243</b>	<b>241</b>	<b>238</b>	<b>235</b>	<b>231</b>	<b>225</b>	<b>205</b>	
	[7.9]	[221]	[515]	[610]	[699]	[884]	[982]	[1132]	[1512]	
L/min	30	25	58	69	79	100	111	128	171	
		<b>370</b>	<b>366</b>	<b>363</b>	<b>360</b>	<b>356</b>	<b>351</b>	<b>346</b>	<b>323</b>	
Flow (L/min)	[9.2]	[212]	[504]	[601]	[690]	[876]	[973]	[1114]	[1512]	
	L/min	24	57	68	78	99	110	126	171	
L/min	35	<b>432</b>	<b>427</b>	<b>424</b>	<b>421</b>	<b>416</b>	<b>412</b>	<b>407</b>	<b>387</b>	
	[11.9]	[195]	[478]	[584]	[681]	[858]	[964]	[1097]	[1495]	
L/min	45	22	54	66	77	97	109	124	169	
		<b>555</b>	<b>550</b>	<b>546</b>	<b>542</b>	<b>538</b>	<b>532</b>	<b>528</b>	<b>503</b>	
Flow (L/min)	[13.2]	[177]	[469]	[566]	[633]	[849]	[946]	[1088]	[1486]	
	L/min	20	53	64	75	96	107	123	168	
L/min	50	<b>616</b>	<b>609</b>	<b>606</b>	<b>603</b>	<b>599</b>	<b>594</b>	<b>588</b>	<b>561</b>	
	[15.8]	[168]	[460]	[557]	[654]	[840]	[946]	[1088]	[1486]	
Max cont.	60	19	52	63	74	95	107	123	168	Max cont.
		<b>740</b>	<b>732</b>	<b>727</b>	<b>723</b>	<b>718</b>	<b>713</b>	<b>707</b>	<b>675</b>	
Max int.	[19.8]	[142]	[416]	[522]	[637]	[805]	[929]	[1070]		
	75	16	47	59	72	91	105	121		Max int.
		<b>827</b>	<b>820</b>	<b>817</b>	<b>813</b>	<b>808</b>	<b>804</b>	<b>796</b>		

YMP 100 [5.87 in<sup>3</sup>/rev] 96.2 cm<sup>3</sup>/rev.

		[435]	[870]	[1015]	[1160]	[1450]	[1595]	[1813]	[2393]	[PSI]
		3	6	7	8	10	11	12	16	MPa
GPM	[2.1]	[318]	[663]	[778]	[893]	[1114]	[1247]	[1415]	[1857]	
	L/min	36	75	88	101	126	141	160	210	
L/min	8	<b>78</b>	<b>75</b>	<b>73</b>	<b>70</b>	<b>63</b>	<b>67</b>	<b>56</b>	<b>34</b>	
	[4.0]	[310]	[663]	[787]	[893]	[1132]	[1247]	[1415]	[1884]	TORQUE (LB-IN)
L/min	15	35	75	89	101	128	141	160	213	TORQUE (N•M)
		<b>149</b>	<b>145</b>	<b>143</b>	<b>141</b>	<b>137</b>	<b>134</b>	<b>129</b>	<b>109</b>	SPEED (RPM)
Flow (L/min)	[5.3]	[292]	[654]	[778]	[893]	[1114]	[1238]	[1424]	[1875]	
	L/min	33	74	88	101	126	140	161	212	
L/min	20	<b>199</b>	<b>196</b>	<b>195</b>	<b>191</b>	<b>189</b>	<b>185</b>	<b>179</b>	<b>161</b>	
	[7.9]	[274]	[637]	[752]	[867]	[1088]	[1212]	[1386]	[1884]	
L/min	30	31	72	85	98	123	137	157	213	
		<b>299</b>	<b>296</b>	<b>293</b>	<b>291</b>	<b>288</b>	<b>284</b>	<b>280</b>	<b>259</b>	
Flow (L/min)	[9.2]	[256]	[610]	[734]	[849]	[1070]	[1194]	[1371]	[1875]	
	L/min	29	69	83	96	121	135	155	212	
L/min	35	<b>349</b>	<b>345</b>	<b>344</b>	<b>341</b>	<b>337</b>	<b>335</b>	<b>330</b>	<b>310</b>	
	[11.9]	[248]	[584]	[716]	[831]	[1052]	[1176]	[1353]	[1840]	
L/min	45	28	66	81	94	119	133	153	208	
		<b>449</b>	<b>445</b>	<b>442</b>	<b>439</b>	<b>435</b>	<b>432</b>	<b>428</b>	<b>405</b>	
Flow (L/min)	[13.2]	[212]	[575]	[690]	[822]	[1565]	[1167]	[1344]	[1831]	
	L/min	24	65	78	93	117	132	152	207	
L/min	50	<b>498</b>	<b>493</b>	<b>491</b>	<b>490</b>	<b>486</b>	<b>481</b>	<b>477</b>	<b>457</b>	
	[15.8]	[203]	[557]	[681]	[814]	[1026]	[1158]	[1335]	[1831]	
Max cont.	60	23	63	77	92	116	131	151	207	Max cont.
		<b>598</b>	<b>593</b>	<b>589</b>	<b>587</b>	<b>583</b>	<b>578</b>	<b>573</b>	<b>549</b>	
Max int.	[19.8]	[177]	[504]	[654]	[778]	[999]	[1141]	[1327]		
	75	20	57	74	88	113	129	150		Max int.
		<b>673</b>	<b>667</b>	<b>664</b>	<b>661</b>	<b>657</b>	<b>654</b>	<b>648</b>		

## PERFORMANCE DATA

YMP 125 [7.19 in<sup>3</sup>/rev] 117,9 cm<sup>3</sup>/rev.

		[435]	[870]	[1015]	[1160]	[1450]	[1595]	[1813]	[2393]	[PSI]
		3	6	7	8	10	11	12	16	MPa
GPM	[2.1]	[398]	[831]	[982]	[1123]	[1397]	[1557]	[1778]	[2326]	
	8	45	94	111	127	158	176	201	263	
L/min	[4.0]	[389]	[831]	[982]	[1123]	[1415]	[1565]	[1786]	[2361]	TORQUE (LB-IN) TORQUE (N•M) SPEED (RPM)
	15	44	94	111	127	160	177	202	267	
Flow (L/min)	[5.3]	[371]	[822]	[973]	[1123]	[1406]	[1557]	[1786]	[2370]	
	20	42	93	110	127	159	176	202	268	
Flow (L/min)	[7.9]	[354]	[808]	[955]	[1097]	[1380]	[1539]	[1751]	[2370]	
	30	40	91	108	124	156	174	198	268	
Flow (L/min)	[9.2]	[336]	[787]	[937]	[1079]	[1362]	[1521]	[1733]	[2361]	
	35	38	89	106	122	154	172	196	267	
Flow (L/min)	[11.9]	[327]	[752]	[911]	[1061]	[1335]	[1503]	[1716]	[2326]	
	45	37	85	103	120	151	170	194	263	
Flow (L/min)	[13.2]	[292]	[743]	[884]	[1044]	[1318]	[1477]	[1698]	[2299]	
	50	33	84	100	118	149	167	192	260	
Max cont.	[15.8]	[283]	[716]	[876]	[1026]	[1300]	[1468]	[1689]	[2291]	Max cont.
	60	32	81	99	116	147	166	191	259	
Max int.	[19.8]	[230]	[663]	[822]	[973]	[1256]	[1406]	[1636]		Max int.
	75	26	75	93	110	142	159	185		

YMP 160 [9.49 in<sup>3</sup>/rev] 155.5 cm<sup>3</sup>/rev.

		[435]	[870]	[1015]	[1160]	[1450]	[1595]	[2030]	[2393]	[PSI]
		3	6	7	8	10	11	14	16	MPa
GPM	[2.1]	[504]	[1070]	[1256]	[1433]	[1786]	[1990]	[2419]	[2954]	
	8	57	121	142	162	202	225	243	334	
L/min	[4.0]	[495]	[1070]	[1256]	[1433]	[1804]	[2008]	[2167]	[3016]	TORQUE (LB-IN) TORQUE (N•M) SPEED (RPM)
	15	56	121	142	162	204	227	245	341	
Flow (L/min)	[5.3]	[486]	[1061]	[1238]	[1433]	[1795]	[1999]	[2158]	[3025]	
	20	55	120	140	162	203	226	244	342	
Flow (L/min)	[7.9]	[478]	[1035]	[1229]	[1415]	[1778]	[1981]	[2140]	[3007]	
	30	54	117	139	160	201	224	242	340	
Flow (L/min)	[9.2]	[460]	[1017]	[1212]	[1406]	[1760]	[1946]	[2140]	[2980]	
	35	52	115	137	159	199	220	242	337	
Flow (L/min)	[11.9]	[442]	[991]	[1185]	[1380]	[1733]	[1946]	[2105]	[2963]	
	45	50	112	134	156	196	220	238	335	
Flow (L/min)	[13.2]	[398]	[973]	[1167]	[1353]	[1716]	[1910]	[2061]	[2919]	
	50	45	110	132	153	194	216	233	330	
Max cont.	[15.8]	[389]	[937]	[1150]	[1335]	[1698]	[1893]	[2043]	[2901]	Max cont.
	60	44	106	130	151	192	214	231	328	
Max int.	[19.8]	[283]	[849]	[1052]	[1256]	[1610]	[1813]	[1963]		Max int.
	75	32	96	119	142	182	205	222		

YMP 200 [11.59 in<sup>3</sup>/rev] 189.9 cm<sup>3</sup>/rev.

		[435]	[870]	[1015]	[1160]	[1450]	[1595]	[2175]	[PSI]
		3	6	7	8	10	11	15	MPa
GPM	[2.1]	[646]	[1353]	[1583]	[1804]	[2264]	[2503]	[3405]	
	8	73	153	179	204	256	283	385	
L/min	[4.0]	[646]	[1344]	[1592]	[1813]	[2291]	[2353]	[3449]	TORQUE (LB-IN) TORQUE (N•M) SPEED (RPM)
	15	73	152	180	205	259	266	390	
Flow (L/min)	[5.3]	[628]	[1335]	[1574]	[1804]	[2264]	[2521]	[3449]	
	20	71	151	178	204	256	285	390	
Flow (L/min)	[7.9]	[601]	[1318]	[1548]	[1786]	[2246]	[2503]	[3431]	
	30	68	149	175	202	254	283	388	
Flow (L/min)	[9.2]	[575]	[1291]	[1530]	[1769]	[2229]	[2485]	[3414]	
	35	65	146	173	200	252	281	386	
Flow (L/min)	[11.9]	[557]	[1256]	[1503]	[1733]	[2184]	[2450]	[3378]	
	45	63	142	170	196	247	259	382	
Flow (L/min)	[13.2]	[513]	[1220]	[1468]	[1707]	[2158]	[2406]	[3343]	
	50	58	138	166	193	244	272	378	
Max cont.	[15.8]	[495]	[1203]	[1442]	[1689]	[2131]	[2379]	[3317]	Max cont.
	60	56	136	163	191	241	269	375	
Max int.	[19.8]	[371]	[1070]	[1327]	[1565]	[1999]			Max int.
	75	42	121	150	177	226			

YMP 250 [14.10 in<sup>3</sup>/rev] 231 cm<sup>3</sup>/rev.

		[435]	[870]	[1015]	[1160]	[1450]	[1595]	[2030]	[PSI]
		3	6	7	8	10	11	14	MPa
GPM	[2.1]	[822]	[1725]	[1999]	[2291]	[2874]	[3157]		
	8	93	195	226	259	325	357		
L/min	[4.0]	[814]	[1698]	[1999]	[2299]	[2874]	[3184]	[4033]	TORQUE (LB-IN) TORQUE (N•M) SPEED (RPM)
	15	92	192	226	260	325	360	456	
Flow (L/min)	[5.3]	[796]	[1689]	[1990]	[2282]	[2848]	[3148]	[4024]	
	20	90	191	225	258	322	356	455	
Flow (L/min)	[7.9]	[761]	[1663]	[1955]	[2255]	[2821]	[3131]	[3997]	
	30	86	188	221	255	319	354	452	
Flow (L/min)	[9.2]	[725]	[1627]	[1919]	[2220]	[2804]	[3095]	[3962]	
	35	82	184	217	251	317	350	448	
Flow (L/min)	[11.9]	[699]	[1583]	[1893]	[2176]	[2759]	[3051]	[3909]	
	45	79	179	214	246	312	345	442	
Flow (L/min)	[13.2]	[654]	[1539]	[1848]	[2149]	[2706]	[2998]	[3874]	
	50	74	174	209	243	306	339	438	
Max cont.	[15.8]	[628]	[1512]	[1822]	[2113]	[2680]	[2972]	[3829]	Max cont.
	60	71	171	206	239	303	336	433	
Max int.	[19.8]	[469]	[1353]	[1672]	[1955]	[2582]	[2759]		Max int.
	75	53	153	189	221	292	312		

## PERFORMANCE DATA

YMP 315 [19.02 in<sup>3</sup>/rev] 311.7 cm<sup>3</sup>/rev.

Max cont.  
Max int.

		[435]	[870]	[1015]	[1160]	[1450]	[1813]	[PSI]
		3	6	7	8	10	12	MPa
GPM	[2.1]	[1026]	[2149]	[2494]	[2768]	[3431]		
	8	116	243	282	313	388		
		<b>25</b>	<b>24</b>	<b>22</b>	<b>16</b>	<b>13</b>		
L/min	[4.0]	[1017]	[2149]	[2512]	[2865]	[3591]	[4449]	TORQUE [LB-IN]
	15	115	243	284	324	406	503	TORQUE (N•M)
		<b>47</b>	<b>46</b>	<b>45</b>	<b>43</b>	<b>41</b>	<b>20</b>	SPEED (RPM)
Flow (L/min)	[5.3]	[1008]	[2140]	[2494]	[2857]	[3582]	[4466]	
	20	114	242	282	323	405	505	
		<b>63</b>	<b>62</b>	<b>61</b>	<b>58</b>	<b>56</b>	<b>54</b>	
Flow (L/min)	[7.9]	[964]	[2096]	[2450]	[2821]	[3546]	[4431]	
	30	109	237	277	319	401	501	
		<b>94</b>	<b>93</b>	<b>92</b>	<b>90</b>	<b>88</b>	<b>77</b>	
Flow (L/min)	[9.2]	[929]	[2052]	[2414]	[2777]	[3511]	[4395]	
	35	105	232	273	314	397	497	
		<b>110</b>	<b>109</b>	<b>108</b>	<b>106</b>	<b>103</b>	<b>93</b>	
Flow (L/min)	[11.9]	[876]	[1999]	[2370]	[2733]	[3458]	[4342]	
	45	99	226	268	309	391	491	
		<b>141</b>	<b>141</b>	<b>139</b>	<b>137</b>	<b>135</b>	<b>124</b>	
Flow (L/min)	[13.2]	[814]	[1928]	[2317]	[2689]	[3396]	[4298]	
	50	92	218	262	304	384	486	
		<b>157</b>	<b>157</b>	<b>155</b>	<b>154</b>	<b>151</b>	<b>141</b>	
Max cont.	[15.8]	[787]	[1901]	[2282]	[2644]	[3352]	[4236]	
	60	89	215	258	299	379	479	Max cont.
		<b>189</b>	<b>188</b>	<b>187</b>	<b>185</b>	<b>182</b>	<b>171</b>	
Max int.	[19.8]	[610]	[1716]	[2097]	[2459]	[3140]		
	75	69	194	237	278	355		Max int.
		<b>236</b>	<b>235</b>	<b>234</b>	<b>232</b>	<b>229</b>		

YMP 400 [23.57 in<sup>3</sup>/rev] 386.2 cm<sup>3</sup>/rev.

Max cont.  
Max int.

		[435]	[870]	[1015]	[1160]	[1232,50]	[1812,50]	[PSI]
		3	6	7	8	8	12	MPa
GPM	[2.1]	[1300]	[2688]	[3131]				
	8	147	304	354				
		<b>20</b>	<b>19</b>	<b>16</b>				
L/min	[4.0]	[1300]	[2724]	[3175]	[3608]	[3847]	[4705]	TORQUE [LB-IN]
	15	147	308	359	408	435	532	TORQUE (N•M)
		<b>37</b>	<b>36</b>	<b>35</b>	<b>33</b>	<b>32</b>	<b>25</b>	SPEED (RPM)
Flow (L/min)	[5.3]	[1273]	[2697]	[3166]	[3599]	[3847]	[4714]	
	20	144	305	358	407	435	533	
		<b>50</b>	<b>49</b>	<b>47</b>	<b>45</b>	<b>43</b>	<b>38</b>	
Flow (L/min)	[7.9]	[1229]	[2662]	[3113]	[3555]	[3803]	[4687]	
	30	139	301	352	402	430	530	
		<b>74</b>	<b>73</b>	<b>72</b>	<b>70</b>	<b>68</b>	<b>62</b>	
Flow (L/min)	[9.2]	[1176]	[2600]	[3051]	[3502]	[3741]	[4643]	
	35	133	294	345	396	423	525	
		<b>86</b>	<b>86</b>	<b>85</b>	<b>82</b>	<b>80</b>	<b>75</b>	
Flow (L/min)	[11.9]	[1105]	[2538]	[2998]	[3440]	[3679]	[4572]	
	45	125	287	339	389	416	517	
		<b>111</b>	<b>111</b>	<b>109</b>	<b>106</b>	<b>105</b>	<b>100</b>	
Flow (L/min)	[13.2]	[1035]	[2459]	[2918]	[3378]	[3591]	[4502]	
	50	117	278	330	382	406	509	
		<b>124</b>	<b>124</b>	<b>122</b>	<b>120</b>	<b>119</b>	<b>113</b>	
Max cont.	[15.8]	[990]	[2423]	[2883]	[3334]	[3573]	[4466]	
	60	112	274	326	377	404	505	Max cont.
		<b>149</b>	<b>149</b>	<b>147</b>	<b>145</b>	<b>144</b>	<b>137</b>	
Max int.	[19.8]	[778]	[2146]	[2635]	[3104]	[3325]		
	75	88	246	298	351	376		Max int.
		<b>185</b>	<b>185</b>	<b>185</b>	<b>182</b>	<b>181</b>		

## DIMENSIONS AND MOUNTING DATA

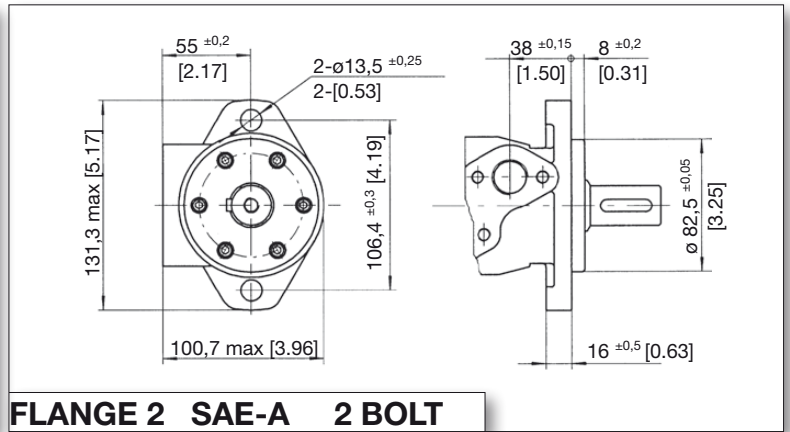
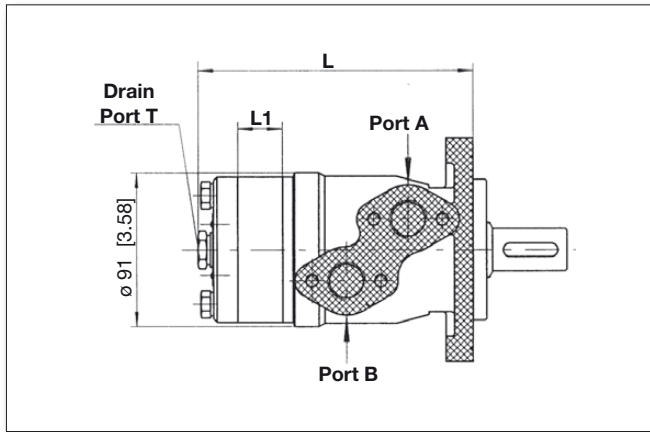

MODEL	[INCHES]		MILLIMETERS	
	L	L1	L	L1
YMP 50	[5.39]	[.28]	137	7
YMP 80	[5.53]	[0.41]	140.5	10.5
YMP 100	[5.63]	[0.51]	143	13
YMP 125	[5.75]	[0.63]	146	16
YMP 160	[5.94]	[0.83]	151	21
YMP 200	[6.18]	[1.02]	157	26
YMP 250	[6.38]	[1.26]	162	32
YMP 315	[6.77]	[1.65]	172	42
YMP 400	[7.17]	[2.05]	182	52

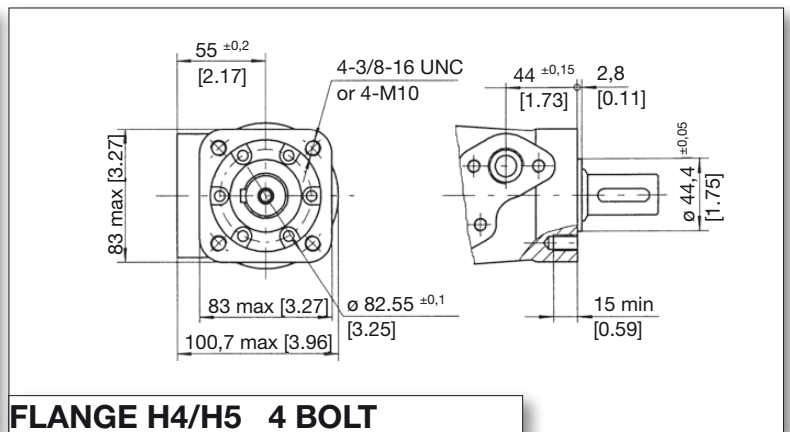
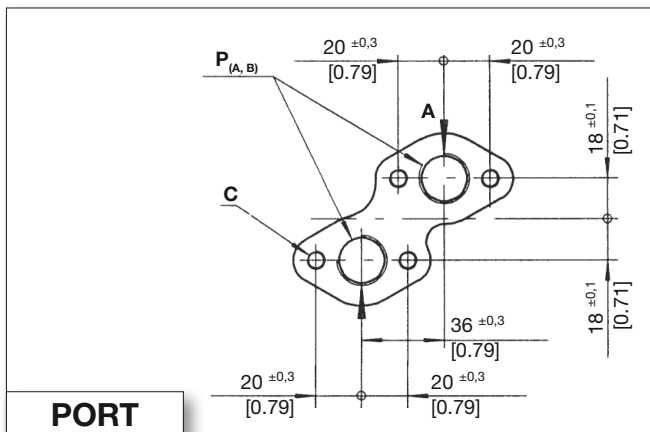
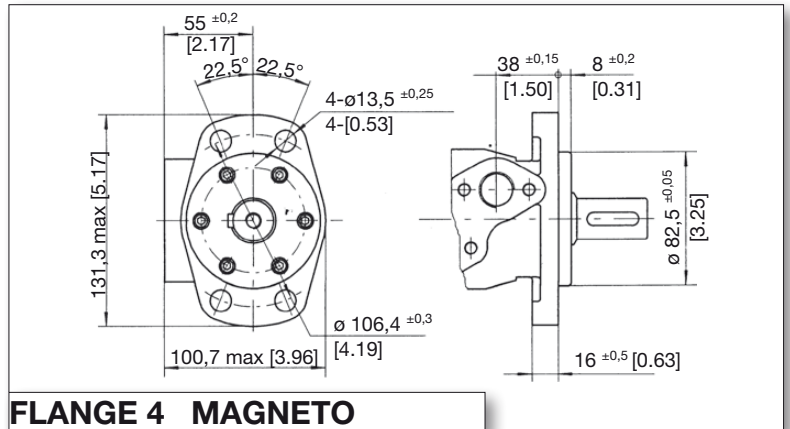

## PORT & DRAIN PORT ORDERING CODES

ORDER CODE	D	DEPTH	M	DEPTH	S	DEPTH	P	DEPTH	R	DEPTH
PORTS - A and B	G 1/2	15 mm	M22 X 1.5	15 mm	7/8-14 O-RING	17 mm	1/2-14NPTF	15 mm	PT(RC)1/2	15 mm
TANK PORT - T	G 1/4	12 mm	M14 X1.5	12 mm	7/16-20UNF	12 mm	7/16-20UNF	12 mm	PT(RC)1/4	9.7 mm
BOLTS - C	4-M8	13 mm	4-M8	13 mm	4-5/16-18UNC	13 mm	4-5/16-18UNC	13 mm	4-M8	13 mm

## MOTOR SHAFT EXTENSIONS

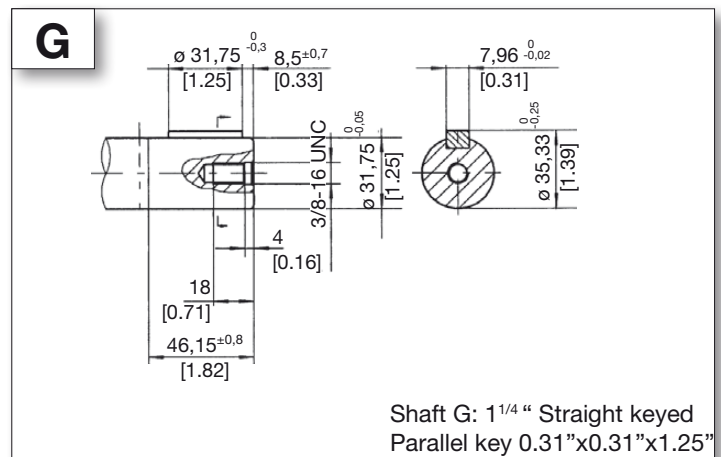
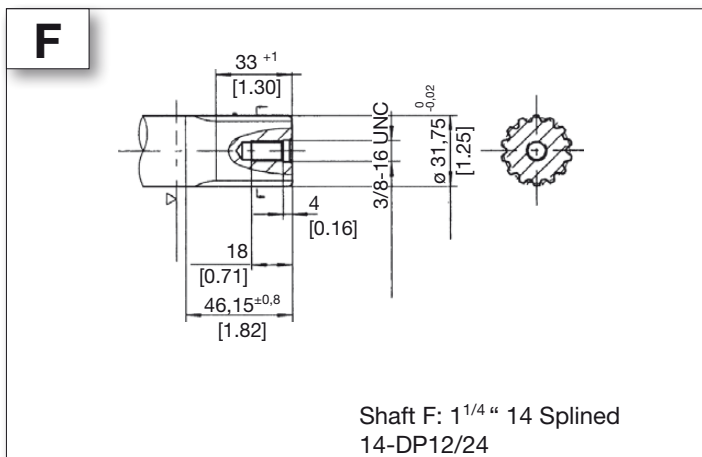
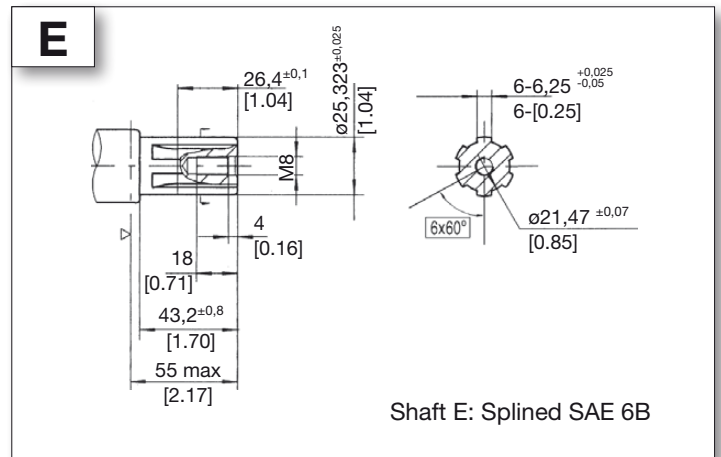
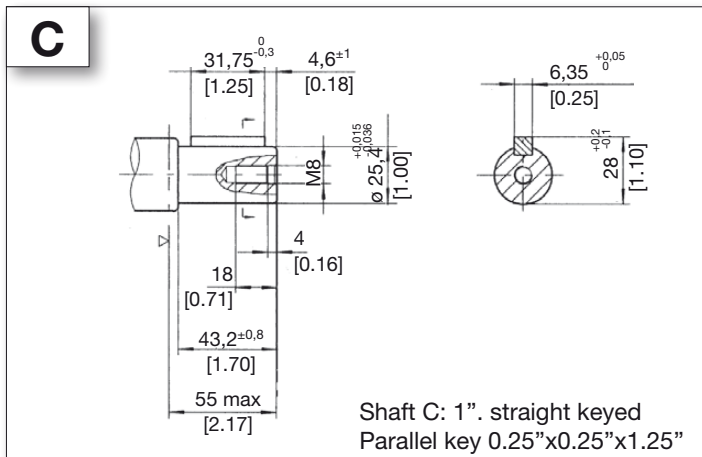
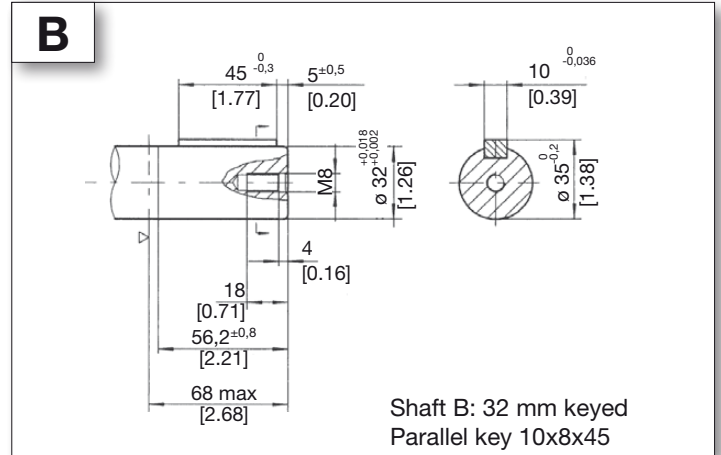
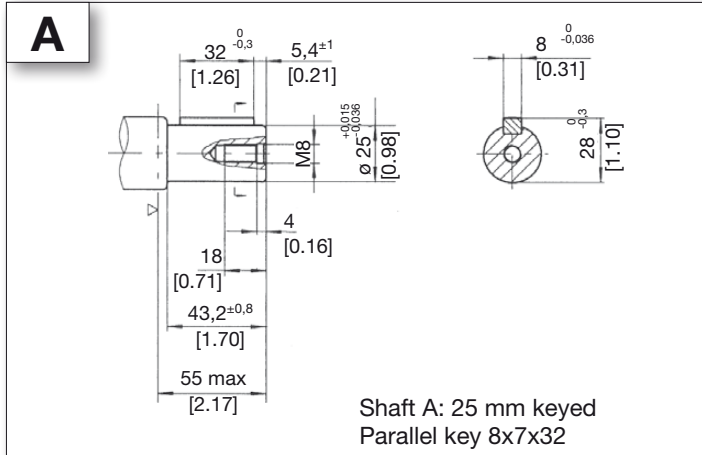

▷ Motor Mounting Surface

## MOTOR SHAFT EXTENSIONS

**T3**

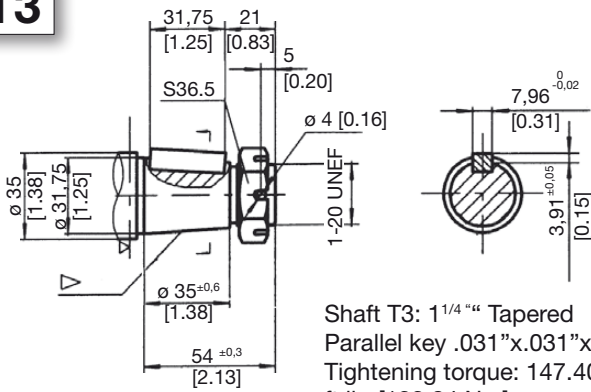

Shaft T3: 1 1/4" Tapered  
Parallel key .031"x.031"x1.25"  
Tightening torque: 147.40±7.37  
ft.lb. [199.84 Nm]

**R**

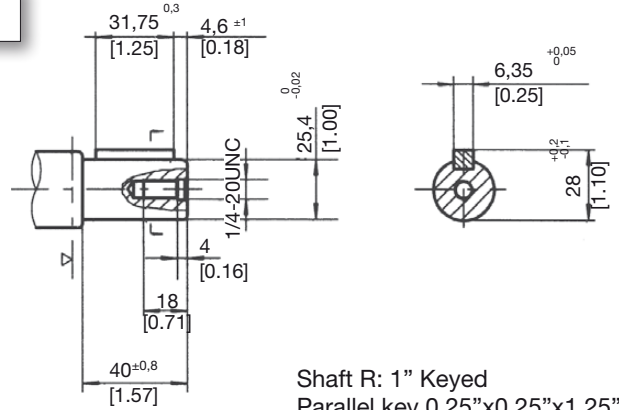

Shaft R: 1" Keyed  
Parallel key 0.25"x0.25"x1.25"

**FD**

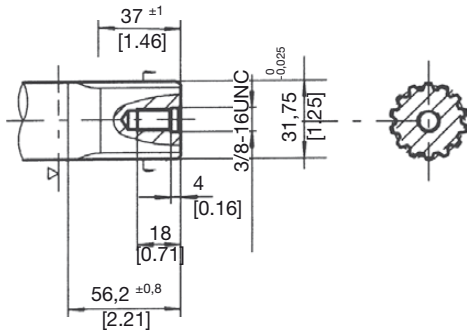

Shaft FD: 1 1/4"-14 Splined  
14-DP12/24

**T**

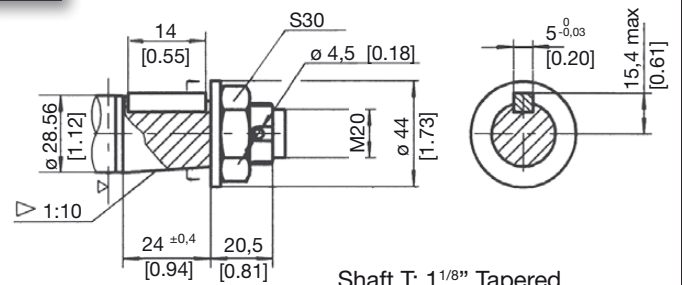

Shaft T: 1 1/8" Tapered  
Parallel key  
Tightening torque: 147.40±7.37  
ft.lb. [199.84 Nm]

## ADDITIONAL INFORMATION

### PERMISSIBLE SHAFT SEAL PRESSURE

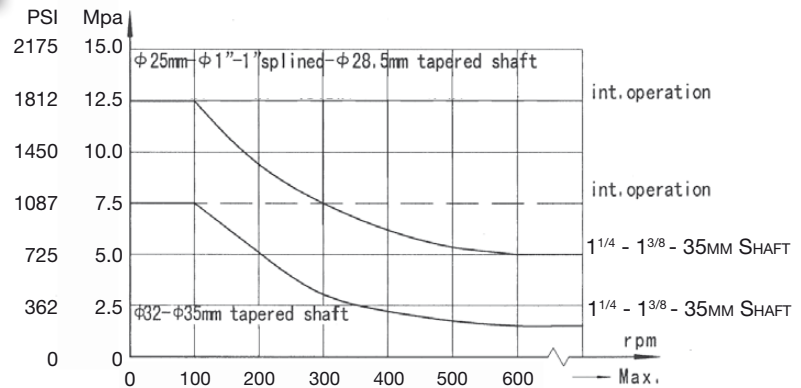
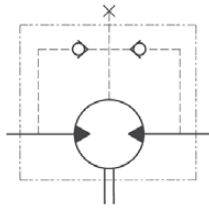

When viewing the motor from the output shaft end, port A is defined to be on the right and port B is defined to be on the left side. Standard rotation motors rotate CW when port A is pressurized. The motors are bi-directional and CCW rotation occurs when port B is pressurized.

Reverse rotation motors can special ordered which will operate with opposite rotation outlined above.

### SHAFT ROTATION DIRECTION

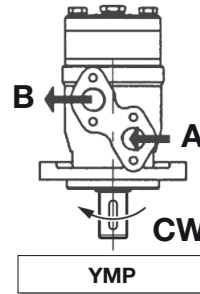

SHAFT ROTATION DIRECTION

### LOAD CHART RATINGS

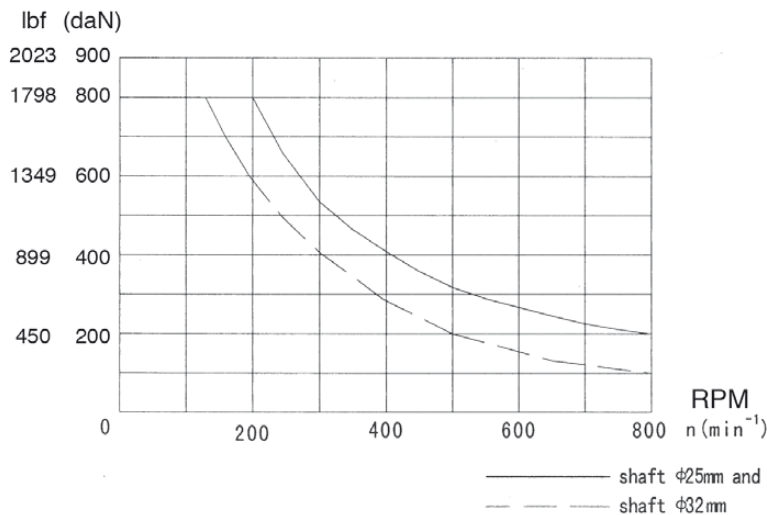

$$F_r = \frac{800 \cdot 25000}{n \cdot 95 + 1} \text{ daN}$$

$F_r$  = Radial Force (daN)  
 $L$  = Distance (mm)  
 $n$  = Speed (rpm)  
 Rhomb-flange  $L=30\text{mm}$   
 Square-flange  $L=24\text{mm}$



## ORDERING INFORMATION

	<b>1</b>	<b>2</b>	<b>3</b>	<b>4</b>	<b>5</b>	<b>6</b>	<b>7</b>
<b>YMP</b>							

1	2	3	4	5	6	7
DISP.	FLANGE	OUTPUT SHAFT	PORT AND DRAIN PORT	ROTATION DIRECTION	PAINT	SPECIAL OPTIONS
36	2 SAE - A 2 Bolt Pilot 3.25"x0.31"	A Shaft 25mm Keyed Parallel key 8x7x32	D Port: G 1/2 Manifold Mount Drain: G 1/4 Bolts: 4 x M8	NONE STANDARD	00 NO PAINT	NONE STANDARD
50	4 4 Bolt Magneto Pilot 3.25"x0.31"	B Shaft 32mm Keyed Parallel key 10x8x45	M Port M22x1.5 Manifold Mount Drain: M14x1.5 Bolts: 4 x M8	R OPPOSITE		N NEEDLE BEARING
80	H4 SAE - A 4 Bolt Pilot 1.75"x0.11" 4 bolts: 3/8 - 16UNC	C Shaft 1" Straight keyed Parallel key 0.25"x0.25"x1.25"	S Port: 7/8"-14 O-ring Manifold Drain: 7/16"-20UNF Bolts: 4 x 5/16"-18UNC,		B BLACK	
100	H5 4 Bolt Flange Pilot Ø44.4x2.8 4 x M10	E Splined SAE 6B	P Port: 1/2"-14 NPTF Manifold Drain: 7/16"-20UNF Bolts: 4 x 5/16"-18UNC			FR FREE RUNNING
125		R Short shaft 1" Keyed Parallel key 0.25"x0.25"x1.25"				
160		F 1 1/4" 14 Splined 14-DP12/24				
200		FD 1 1/4" 14 Splined (long) 14-DP12/24	R Port: PT(Rc)1/2" Manifold Drain: PT(Rc)1/4" Bolts: 4 x M8			LSV LOW SPEED VALVE
250		G 1 1/4" Straight keyed Parallel key 0.31"x0.31"x1.25"				CRS CORROSION RESISTANT SHAFT
315		T 1 1/8" Tapered Parallel key 0.20"x0.20"x0.55"				HPS HIGH PRESSURE SEAL
400		T3 1 1/4" Tapered Parallel key 0.31"x0.31"x1.00"				HTS HIGH TEMP SEAL

**ORDERING CODE:**

All options have been determined with letters, numbers or combinations. All boxes must be filled with proper codes. If specification is not in the table, please contact us with your requirements.



# YMPH



The **YMPH** series motor uses the spool valve shaft distribution design for simplicity, efficiency and compactness. This design integrates the distribution and hydraulic bearing design with the motor shaft.

This design has identical displacement and performance of the YMP series with a few different options.

The inlet and outlet ports (A & B) are parallel with the mounting flange to meet certain application requirements. The SAE flange is available for these ports.

## SPECIFICATIONS

Distribution Type	Model	Displacement		Max. Operating Pressure		Speed Range Continuous	Max. Output Power	
		[in <sup>3</sup> ./rev]	[2.18~24.41]	[PSI]	[2400]		[HP]	[12]
Spool Valve Distribution	YMPH	cm <sup>3</sup> /rev.	<b>36 ~ 400</b>	MPa	16.5	30~879	Kw	9

## QUICK REFERENCE GUIDE

### YMPH SERIES QUICK REFERENCE:

Displacements				
[in <sup>3</sup> ./rev]	cm <sup>3</sup> /rev.			
[2.18]	36			
[3.15]	51.7	FLOW UP TO	75 LPM	[20 GPM]
[4.74]	77.7	PRESSURE UP TO	16.5 MPa	[2392 PSI]
[5.87]	96.2	TORQUE UP TO	533 Nm	[4847 lb.-in.]
[7.19]	117.9	SPEED UP TO	975 RPM	
[9.49]	155.5			
[11.59]	189.9			
[14.10]	231			
[23.28]	311.7			
[23.57]	386.2			

**Shaft Seals:** Standard high pressure shaft seals permit applications in series or without drain line when required

**Low Speed Valving:** These motors are manufactured following strict procedures to reduce tolerances between all components to permit lower speed, higher efficiency and smoother rotation at very low speeds. These motors are not for high speed or low pressure applications.

**Free Running:** Motors with this option have increased clearances in the rotor set. This allows improved mechanical efficiency, longer life and better performance for high-speed / high-flow applications, winch or similar applications where the motor is cross-ported to allow manual free turning also remay benefit from this option to allow smoother easier free turning of the motor. Last, applications which have many reversals or high pressure spikes can also benefit since the pressure spikes will be reduced by relieving (cross-porting) such spikes internally in the motor. The trade off of these benefits is a slight reduction in volumetric efficiency, particularly at high pressure conditions.

**Special Motors:** These motors have special options like nickel plated shafts or housings for applications in corrosive environments.

### APPLICATION GUIDELINES:

For optimum results the following working conditions are recommended:

- \* Oil temperature should be between 20° - 60° C [68° - 180° F]
- \* Oil filter of 10 - 20 micron
- \* Oil viscosity 42 - 74 mm<sup>2</sup>/s CSA at 40° C
- \* Different shafts are used when there is a radial load or not. Check data pages
- \* For longer life we suggest the motor at start up, run for a shorter period of time (one hour) at no more than 30% of rated speed and pressure.

## SPECIFICATION DATA

For individual motor performance chart consult equivalent YMP series data.

DISTRIBUTION TYPE		YMPH 36	YMPH 50	YMPH 80	YMPH 100	YMPH 125	YMPH 160	YMPH 200	YMPH 250	YMPH 315	YMPH 400	
GEOMETRIC DISPLACEMENT	[in <sup>3</sup> ./rev.]	[2.20]	[3.15]	[4.74]	[5.87]	[7.19]	[9.49]	[11.59]	[14.10]	[19.01]	[23.57]	
	cm <sup>3</sup> /rev.	<b>36</b>	<b>51.7</b>	<b>77.7</b>	<b>96.2</b>	<b>117.9</b>	<b>155.5</b>	<b>189.9</b>	<b>231</b>	<b>311.7</b>	<b>386.2</b>	
MAX. SPEED RPM	CONT.	1078	879	740	589	475	370	296	237	189	149	
	INT.	<b>1210</b>	<b>975</b>	<b>827</b>	<b>673</b>	<b>594</b>	<b>463</b>	<b>370</b>	<b>297</b>	<b>236</b>	<b>185</b>	
MAX. TORQUE [LB. IN.] N*M	CONT.	[LB. IN.]	[486]	[716]	[1141]	[1424]	[1786]	[2167]	[2529]	[3184]	[3591]	[4847]
		N*M	<b>55</b>	<b>81</b>	<b>129</b>	<b>161</b>	<b>202</b>	<b>245</b>	<b>286</b>	<b>360</b>	<b>406</b>	<b>435</b>
	INT.	[LB. IN.]	[672]	[955]	[1512]	[1884]	[2370]	[3025]	[3449]	[4033]	[4466]	[4714]
		N*M	<b>76</b>	<b>108</b>	<b>171</b>	<b>213</b>	<b>268</b>	<b>342</b>	<b>390</b>	<b>456</b>	<b>505</b>	<b>533</b>
MAX. OUTPUT [HP] KW	CONT.	[HP]	[8]	[9]	[12]	[12]	[12]	[11]	[11]	[10]	[10]	
		KW	<b>6</b>	<b>7</b>	<b>9.1</b>	<b>9</b>	<b>9.1</b>	<b>8.7</b>	<b>8.1</b>	<b>8.2</b>	<b>7.2</b>	<b>6.1</b>
	INT.	[HP]	[10]	[12]	[16]	[16]	[16]	[16]	[15]	[14]	[12]	[10]
		KW	<b>8</b>	<b>8.9</b>	<b>11.8</b>	<b>11.9</b>	<b>11.8</b>	<b>11.9</b>	<b>10.9</b>	<b>10.1</b>	<b>8.6</b>	<b>7.2</b>
MAX. PRES-SURE DROP [PSI] MPA	CONT.	[PSI]	[1812]	[1812]	[1812]	[1812]	[1812]	[1595]	[1595]	[1595]	[1450]	
		MPa	<b>12.5</b>	<b>12.5</b>	<b>12.5</b>	<b>12.5</b>	<b>12.5</b>	<b>12.5</b>	<b>11</b>	<b>11</b>	<b>11</b>	<b>10</b>
	INT.	[PSI]	[2392]	[2392]	[2392]	[2392]	[2392]	[2392]	[2392]	[2030]	[1812]	[1522]
		MPa	<b>16.5</b>	<b>16.5</b>	<b>16.5</b>	<b>16.5</b>	<b>16.5</b>	<b>16.5</b>	<b>16.5</b>	<b>14</b>	<b>12.5</b>	<b>10.5</b>
	PEAK	[PSI]	[2392]	[2392]	[2392]	[2392]	[2392]	[2392]	[2392]	[2030]	[1812]	[1522]
		MPa	<b>16.5</b>	<b>16.5</b>	<b>16.5</b>	<b>16.5</b>	<b>16.5</b>	<b>16.5</b>	<b>16.5</b>	<b>14</b>	<b>12.5</b>	<b>10.5</b>
MAX. FLOW [GPM] L/MIN	CONT.	[GPM]	[10.4]	[11.8]	[15.8]	[15.8]	[15.8]	[15.8]	[15.8]	[15.8]	[15.8]	
		L/MIN	<b>40</b>	<b>45</b>	<b>60</b>	<b>60</b>	<b>60</b>	<b>60</b>	<b>60</b>	<b>60</b>	<b>60</b>	
	INT.	[GPM]	[11.8]	[13.2]	[19.8]	[19.8]	[19.8]	[19.8]	[19.8]	[19.8]	[19.8]	
		L/MIN	<b>45</b>	<b>50</b>	<b>75</b>	<b>75</b>	<b>75</b>	<b>75</b>	<b>75</b>	<b>75</b>	<b>75</b>	
WEIGHT [LB] KG	[LB]	[12]	[12]	[13]	[13]	[13]	[14]	[14]	[15]	[15]	[16]	
	KG	<b>5.6</b>	<b>5.6</b>	<b>5.7</b>	<b>5.9</b>	<b>6</b>	<b>6.2</b>	<b>6.4</b>	<b>6.6</b>	<b>6.9</b>	<b>7.5</b>	

\* Continuous pressure:

\* Intermittent pressure:

\* Peak pressure:

Max. value of operating motor continuously.

Max. value of operating motor in 6 seconds per minute.

Max. value of operating motor in 0.6 second per minute.

## DIMENSIONS AND MOUNTING DATA

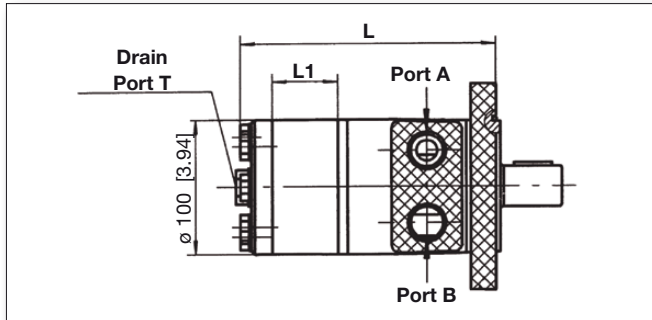

MODEL	[INCHES]		MILLIMETERS	
	L	L1	L	L1
YMPH 50	[5.55]	[0.28]	141	7
YMPH 80	[5.67]	[0.41]	144.5	10.5
YMPH 100	[5.79]	[0.51]	147	13
YMPH 125	[5.91]	[0.63]	150	16
YMPH 160	[6.10]	[0.83]	155	21
YMPH 200	[6.30]	[1.02]	160	26
YMPH 250	[6.54]	[1.26]	166	32
YMPH 315	[6.93]	[1.65]	176	42
YMPH 375	[7.32]	[2.05]	186	52

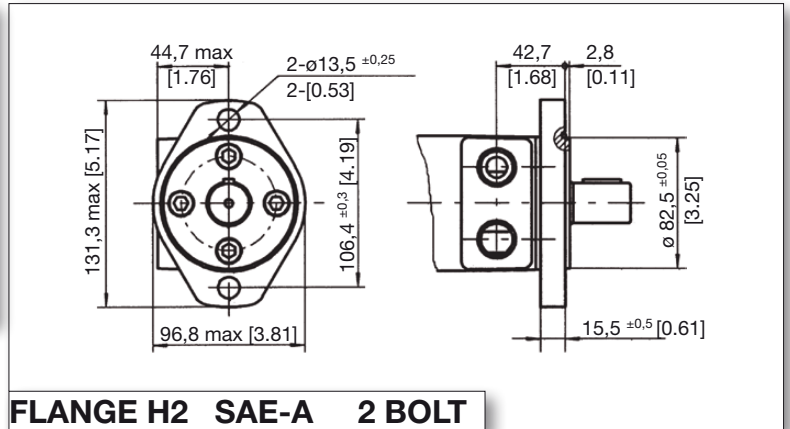

**FLANGE H2 SAE-A 2 BOLT**

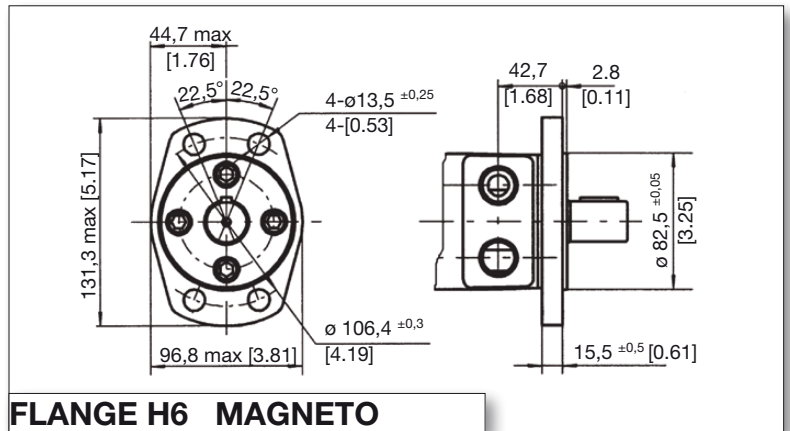

**FLANGE H6 MAGNETO**

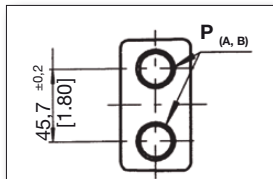

**PORT G-S-P-T-R**

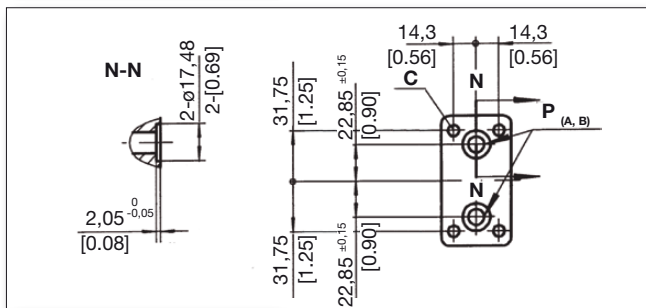

**PORT B4 - B5**

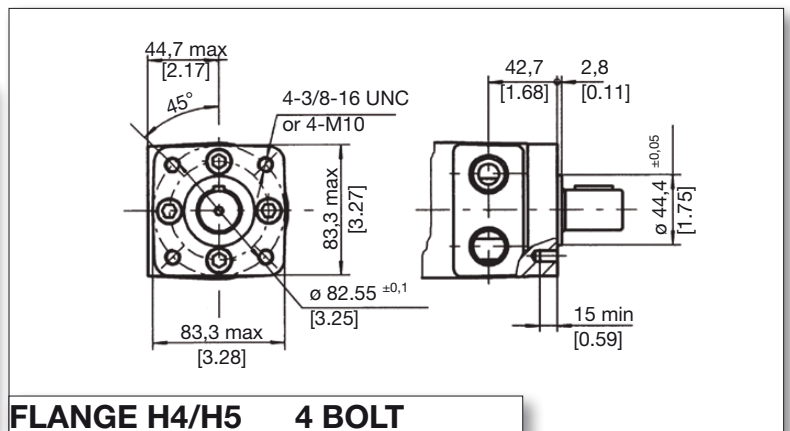

**FLANGE H4/H5 4 BOLT**

## PORT & DRAIN PORT ORDERING CODES

ORDER CODE	G	DEPTH	S	DEPTH	P	DEPTH	T	DEPTH	R	DEPTH	B4	DEPTH	B5	DEPTH
PORTS - A and B	G 1/2	15 mm	7/8-14 O-RING	17 mm	1/2-14NPTF	15 mm	3/4 16 O-RING	15 mm	PT(RC) 1/2	15 mm	Ø10	-	Ø10	-
TANK PORT - T	G 1/4	12 mm	7/16-20UNF	12 mm	7/16-20UNF	12 mm	7/16-20UNF	12 mm	PT(RC) 1/4	9.7 mm	7/16 20UNF	12 mm	G 1/4	12 mm
BOLTS - C	-	-	-	-	-	-	-	-	-	-	4-5/16 18UNC	13 mm	4-M8	13 mm

## MOTOR SHAFT EXTENSIONS

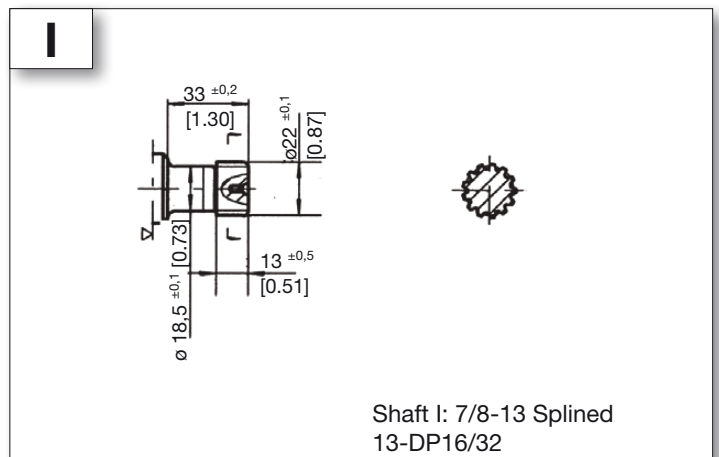
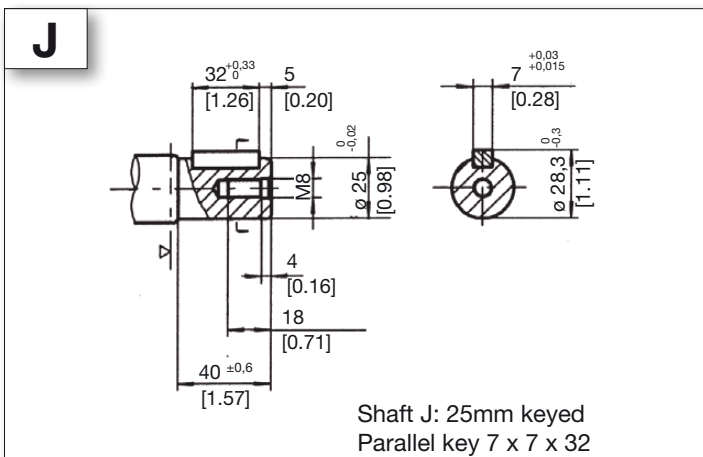
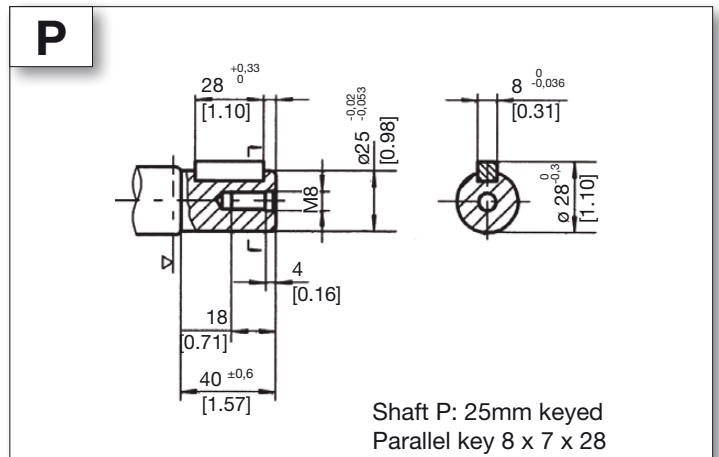
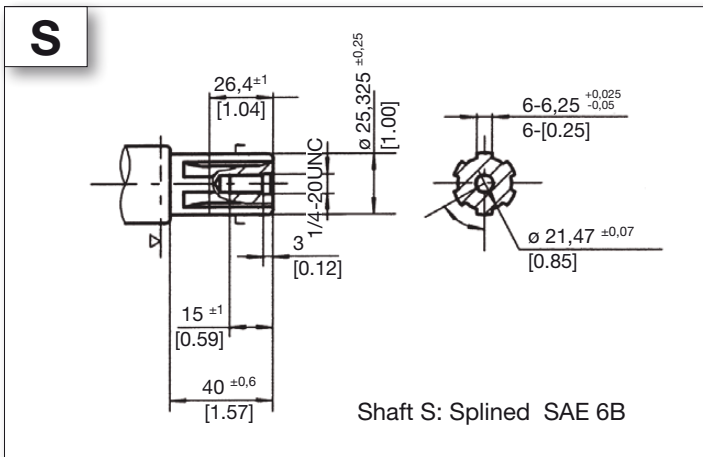
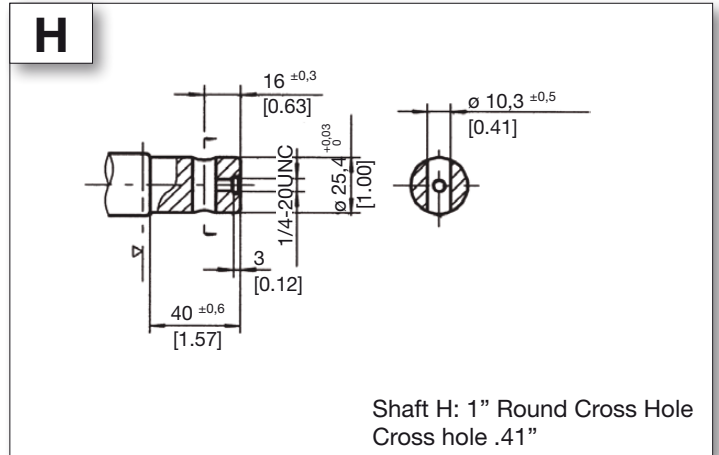
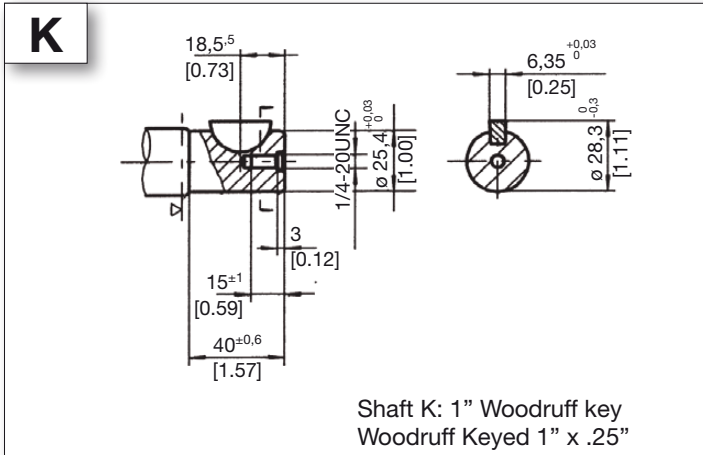

▷ Motor Mounting Surface

## MOTOR SHAFT EXTENSIONS

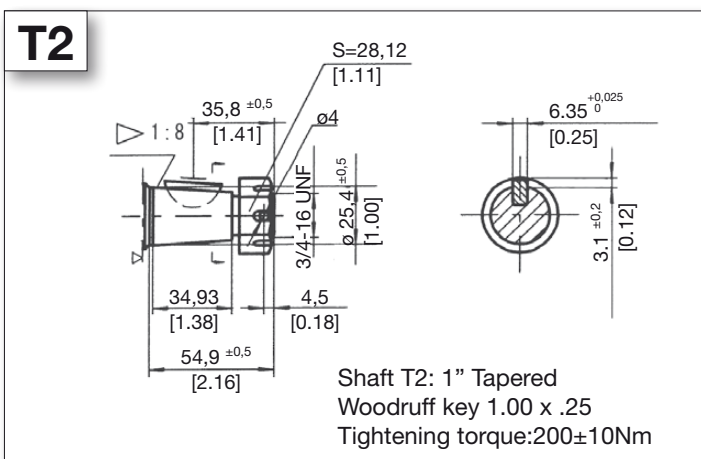
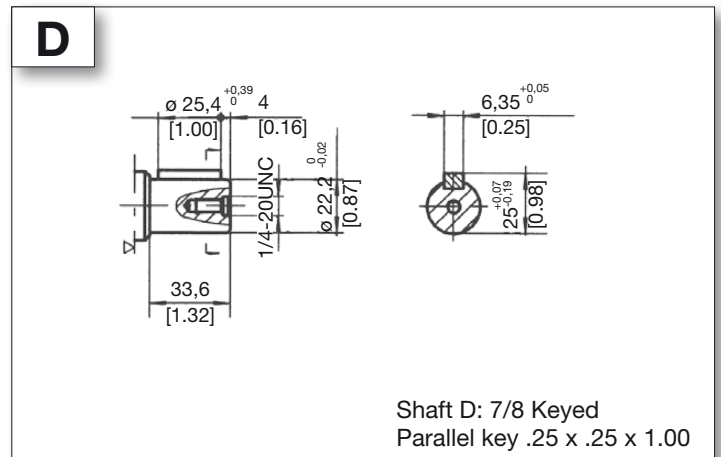
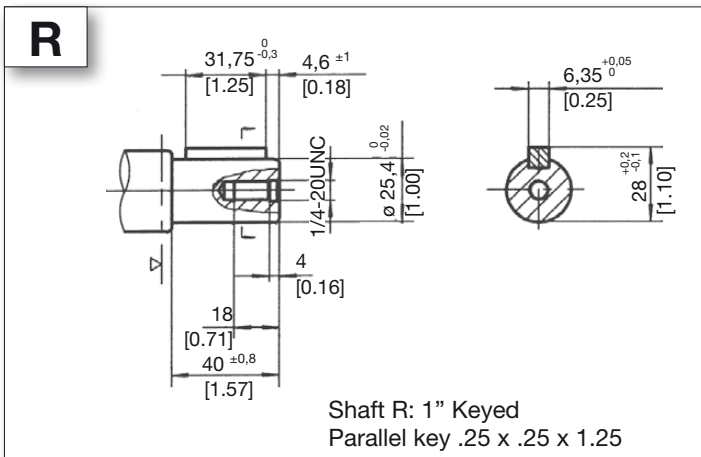
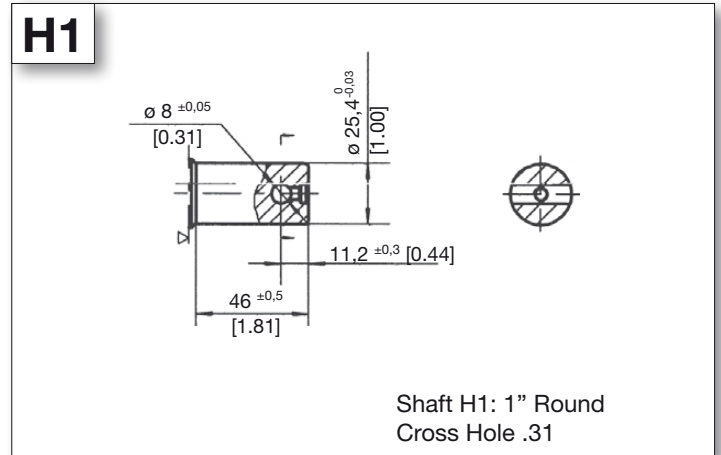
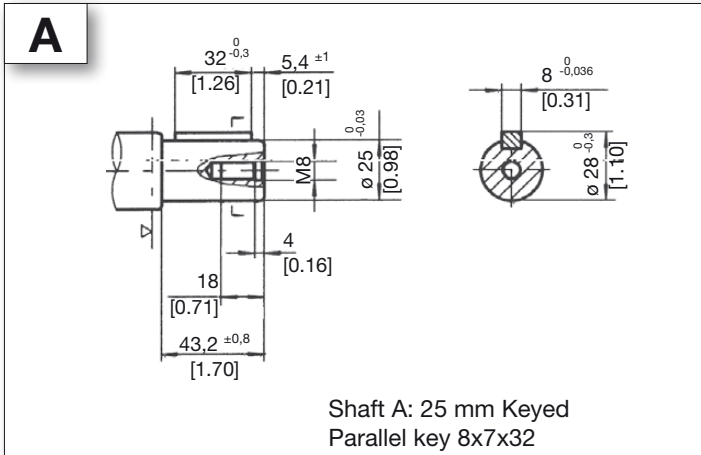



## ADDITIONAL INFORMATION

### PERMISSIBLE SHAFT SEAL PRESSURE

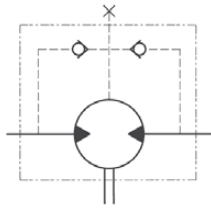

Note: Curve 1 for standard shaft seal  
Curve 2 for high pressure shaft seal

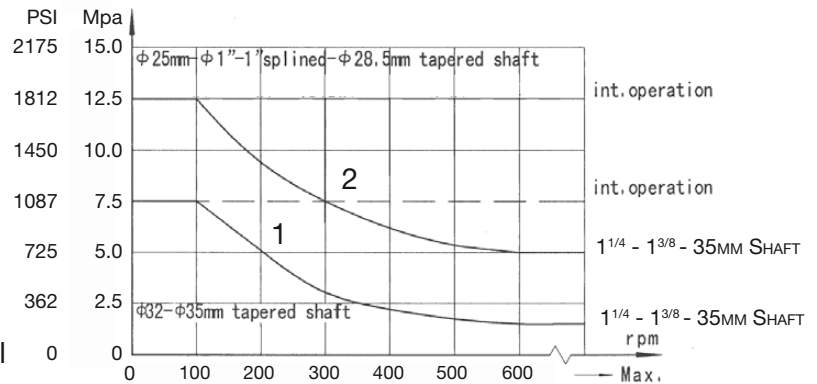

When viewing the motor from the output shaft end, port A is defined to be on the right and port B is defined to be on the left side. Standard rotation motors rotate CW when port A is pressurized. The motors are bi-directional and CCW rotation occurs when port B is pressurized.

Reverse rotation motors can special ordered which will operate with opposite rotation outlined above.

### SHAFT ROTATION DIRECTION

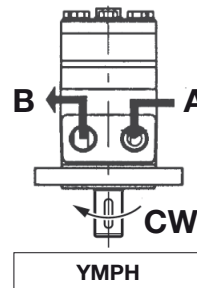

### LOAD CHART RATINGS

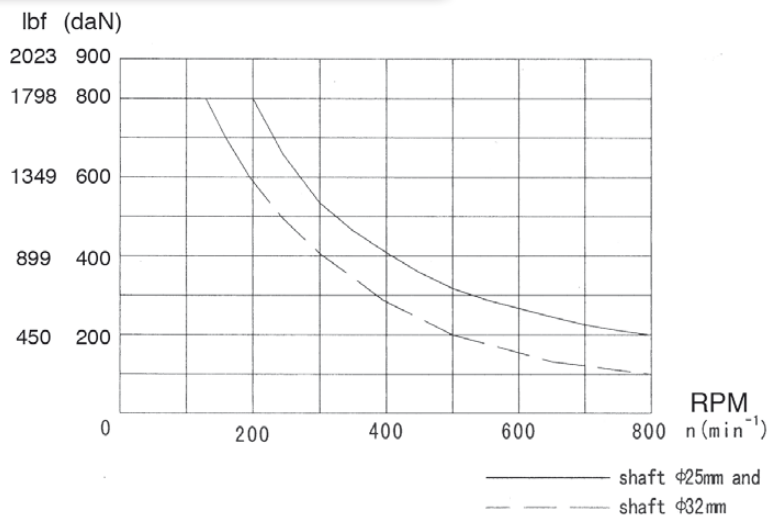

$$F_r = \frac{800,2500}{n,95+1} \text{ daN}$$

$F_r$  = Radial Force (daN)  
 $L$  = Distance (mm)  
 $n$  = Speed (rpm)  
 Rhomb-flange  $L=30\text{mm}$   
 Square-flange  $L=24\text{mm}$

## ORDERING INFORMATION

	<b>1</b>	<b>2</b>	<b>3</b>	<b>4</b>	<b>5</b>	<b>6</b>	<b>7</b>
<b>YMPH</b>							

1	2		3		4		5		6		7	
DISP.	FLANGE		OUTPUT SHAFT		PORT AND DRAIN PORT		ROTATION DIRECTION		PAINT		SPECIAL OPTIONS	
36	H2	SAE - A 2 Bolt Pilot 3.25"x0.31"	K	Shaft: 1" woodruff Key Woodruff key 1"x.25	G	G 1/2,G 1/4	NONE	STANDARD	00	NO PAINT	NONE	STANDARD
50	H6	4 Bolt Magneto Pilot 3.25"x0.31"	H	Shaft:1" Round Cross Hole Cross Hole .41'	S	7/8-14 O-ring , 7/16-20 UNF	R	REVERSE			N	NEEDLE BEARING
80	H4	4 Bolt Flange Pilot 1.75"x0.11" 4 bolts: 3/8 - 16UNC	S	Shaft: Splined SAE 6B	P	1/2-14NPTF, 7/16-20UNF			B	BLACK		
100	H5	4 Bolt Flange Pilot Ø44.4x2.8 4 x M10	P	Shaft:25mm Keyed Parallel Key 8x7x28	T	3/4-16 O-ring, 7/16-20 UNF						
125			J	Shaft: 25mm Keyed Parallel Key 7x7x32	R	Port: PT(Rc)1/2" PT(Rc)1/4"					FR	FREE RUNNING
160			I	Shaft: 7/8-13 Splined	B4	10mm O-ring MANIFOLD 4X5/16-18UNC, 7/16-20UNF (G1/4)						
200			A	Shaft 25mm Keyed Parallel key 8x7x32	B5	10 MM O-ring MANIFOLD 4XM8, 7/16-20 UNF (G1/4)					LSV	LOW SPEED VALVE
250			H1	Shaft: 1" Round Cross Hole Cross Hole .31	S1	7/8 - 14 O-ring rear port					CRS	CORROSION RESISTANT SHAFT
315			R	Shaft: 1" Keyed Parallel Key .25x.25x1.25							HPS	HIGH PRESSURE SEAL
400			D	Shaft: 7/8 Keyed Parallel Key .25x.25x1.00							HTS	HIGH TEMP SEAL
			T2	Shaft: 1" Tapered Woodruff Key 1.00x.25								
			KH	1" Woodruff Key Hole W/0.41" Cross Hole								
			KH1	1" Woodruff Key Hole W/0.31" Cross Hole								

ORDERING CODE:

All options have been determined with letters, numbers or combinations. All boxes must be filled with proper codes. If specification is not in the table, please contact us with your requirements.

# YMPW

The **YMPW** series motor uses the spool valve shaft distribution design for simplicity, efficiency and compactness. This design integrates the distribution and hydraulic bearing design with the motor shaft.

This design has identical displacement and performance of the YMP series with a few different options.

The inlet and outlet ports (A & B) are parallel with the mounting flange to meet certain application requirements. The SAE flange is available for these ports.

## SPECIFICATIONS

Distribution Type	Model	Displacement		Max. Operating Pressure		Speed Range Continuous	Max. Output Power	
		[in <sup>3</sup> ./rev]	[3.05~24.41]	[PSI]	[2400]		[HP]	[14]
Spool Valve Distribution	YMPW	cm <sup>3</sup> /rev.	50 ~ 400	MPa	16.5	30~879	Kw	10

## QUICK REFERENCE GUIDE

### YMPW SERIES QUICK REFERENCE:

Displacements				
[in <sup>3</sup> ./rev]	cm <sup>3</sup> /rev.			
[3.15]	51.7	FLOW UP TO	75 LPM	[20 GPM]
[4.74]	77.7	PRESSURE UP TO	16.5 MPa	[2392 PSI]
[5.87]	96.2	TORQUE UP TO	533 Nm	[4847 lb.-in.]
[7.19]	117.9	SPEED UP TO	975 RPM	
[9.49]	155.5			
[11.59]	189.9			
[14.10]	231			
[19.01]	311.7			
[23.57]	386.2			

**Shaft Seals:** Standard high pressure shaft seals permit applications in series or without drain line when required

**Low Speed Valving:** These motors are manufactured following strict procedures to reduce tolerances between all components to permit lower speed, higher efficiency and smoother rotation at very low speeds. These motors are not for high speed or low pressure applications.

**Free Running:** Motors with this option have increased clearances in the rotor set. This allows improved mechanical efficiency, longer life and better performance for high-speed / high-flow applications, winch or similar applications where the motor is cross-ported to allow manual free turning also remay benefit from this option to allow smoother easier free turning of the motor. Last, applications which have many reversals or high pressure spikes can also benefit since the pressure spikes will be reduced by relieving (cross-porting) such spikes internally in the motor. The trade off of these benefits is a slight reduction in volumetric efficiency, particularly at high pressure conditions.

**Special Motors:** These motors have special options like nickel plated shafts or housings for applications in corrosive environments.

### APPLICATION GUIDELINES:

For optimum results the following working conditions are recommended:

- \* Oil temperature should be between 20° - 60° C [68° - 180° F]
- \* Oil filter of 10 - 20 micron
- \* Oil viscosity 42 - 74 mm<sup>2</sup>/s CSA at 40° C
- \* Different shafts are used when there is a radial load or not. Check data pages
- \* For longer life we suggest the motor at start up run for a shorter period of time (one hour) at no more than 30% of rated speed and pressure.

## SPECIFICATION DATA

For individual motor performance chart consult equivalent YMP series data.

DISTRIBUTION TYPE		YMPW 50	YMPW 80	YMPW 100	YMPW 125	YMPW 160	YMPW 200	YMPW 250	YMPW 315	YMPW 400	
GEOMETRIC DISPLACEMENT	[in <sup>3</sup> /rev.]	[3.15]	[4.74]	[5.87]	[7.19]	[9.49]	[11.59]	[14.10]	[19.01]	[23.57]	
	cm <sup>3</sup> /rev.	<b>51.7</b>	<b>77.7</b>	<b>96.2</b>	<b>117.9</b>	<b>155.5</b>	<b>189.9</b>	<b>231</b>	<b>311.7</b>	<b>386.2</b>	
MAX. SPEED RPM	CONT.	879	740	589	475	370	296	237	189	149	
	INT.	<b>975</b>	<b>827</b>	<b>673</b>	<b>594</b>	<b>463</b>	<b>370</b>	<b>297</b>	<b>236</b>	<b>185</b>	
MAX. TORQUE [LB. IN.] N*M	CONT.	[LB. IN.]	[716]	[1141]	[1424]	[1786]	[2167]	[2529]	[3184]	[3591]	[4847]
		<b>N*M</b>	<b>81</b>	<b>129</b>	<b>161</b>	<b>202</b>	<b>245</b>	<b>286</b>	<b>360</b>	<b>406</b>	<b>435</b>
	INT.	[LB. IN.]	[955]	[1512]	[1884]	[2370]	[3025]	[3449]	[4033]	[4466]	[4714]
		<b>N*M</b>	<b>108</b>	<b>171</b>	<b>213</b>	<b>268</b>	<b>342</b>	<b>390</b>	<b>456</b>	<b>505</b>	<b>533</b>
MAX. OUTPUT [HP] KW	CONT.	[HP]	[9]	[12]	[12]	[12]	[12]	[11]	[11]	[10]	[10]
		<b>KW</b>	<b>7</b>	<b>9.1</b>	<b>9</b>	<b>9.1</b>	<b>8.7</b>	<b>8.1</b>	<b>8.2</b>	<b>7.2</b>	<b>6.1</b>
	INT.	[HP]	[12]	[16]	[16]	[16]	[16]	[15]	[14]	[12]	[10]
		<b>KW</b>	<b>8.9</b>	<b>11.8</b>	<b>11.9</b>	<b>11.8</b>	<b>11.9</b>	<b>10.9</b>	<b>10.1</b>	<b>8.6</b>	<b>7.2</b>
MAX. PRESSURE DROP [PSI] MPa	CONT.	[PSI]	[1812]	[1812]	[1812]	[1812]	[1812]	[1595]	[1595]	[1595]	[1450]
		<b>MPa</b>	<b>12.5</b>	<b>12.5</b>	<b>12.5</b>	<b>12.5</b>	<b>12.5</b>	<b>11</b>	<b>11</b>	<b>11</b>	<b>10</b>
	INT.	[PSI]	[2392]	[2392]	[2392]	[2392]	[2392]	[2392]	[2030]	[1812]	[1522]
		<b>MPa</b>	<b>16.5</b>	<b>16.5</b>	<b>16.5</b>	<b>16.5</b>	<b>16.5</b>	<b>16.5</b>	<b>14</b>	<b>12.5</b>	<b>10.5</b>
	PEAK	[PSI]	[2392]	[2392]	[2392]	[2392]	[2392]	[2392]	[2030]	[1812]	[1522]
		<b>MPa</b>	<b>16.5</b>	<b>16.5</b>	<b>16.5</b>	<b>16.5</b>	<b>16.5</b>	<b>16.5</b>	<b>14</b>	<b>12.5</b>	<b>10.5</b>
MAX. FLOW [GPM] L/MIN	CONT.	<b>[GPM]</b>	[11.8]	[15.8]	[15.8]	[15.8]	[15.8]	[15.8]	[15.8]	[15.8]	[15.8]
		<b>L/MIN</b>	<b>45</b>	<b>60</b>	<b>60</b>	<b>60</b>	<b>60</b>	<b>60</b>	<b>60</b>	<b>60</b>	<b>60</b>
	INT.	<b>[GPM]</b>	[13.2]	[19.8]	[19.8]	[19.8]	[19.8]	[19.8]	[19.8]	[19.8]	[19.8]
		<b>L/MIN</b>	<b>50</b>	<b>75</b>	<b>75</b>	<b>75</b>	<b>75</b>	<b>75</b>	<b>75</b>	<b>75</b>	<b>75</b>
WEIGHT [LB] KG	[LB]	[12]	[13]	[13]	[13]	[14]	[14]	[15]	[15]	[16]	
	<b>KG</b>	<b>5.6</b>	<b>5.7</b>	<b>5.9</b>	<b>6</b>	<b>7.5</b>	<b>7.5</b>	<b>7.5</b>	<b>6.9</b>	<b>7.5</b>	

- \* Continuous pressure: Max. value of operating motor continuously.
- \* Intermittent pressure: Max. value of operating motor in 6 seconds per minute.
- \* Peak pressure: Max. value of operating motor in 0.6 second per minute.

## DIMENSIONS AND MOUNTING DATA

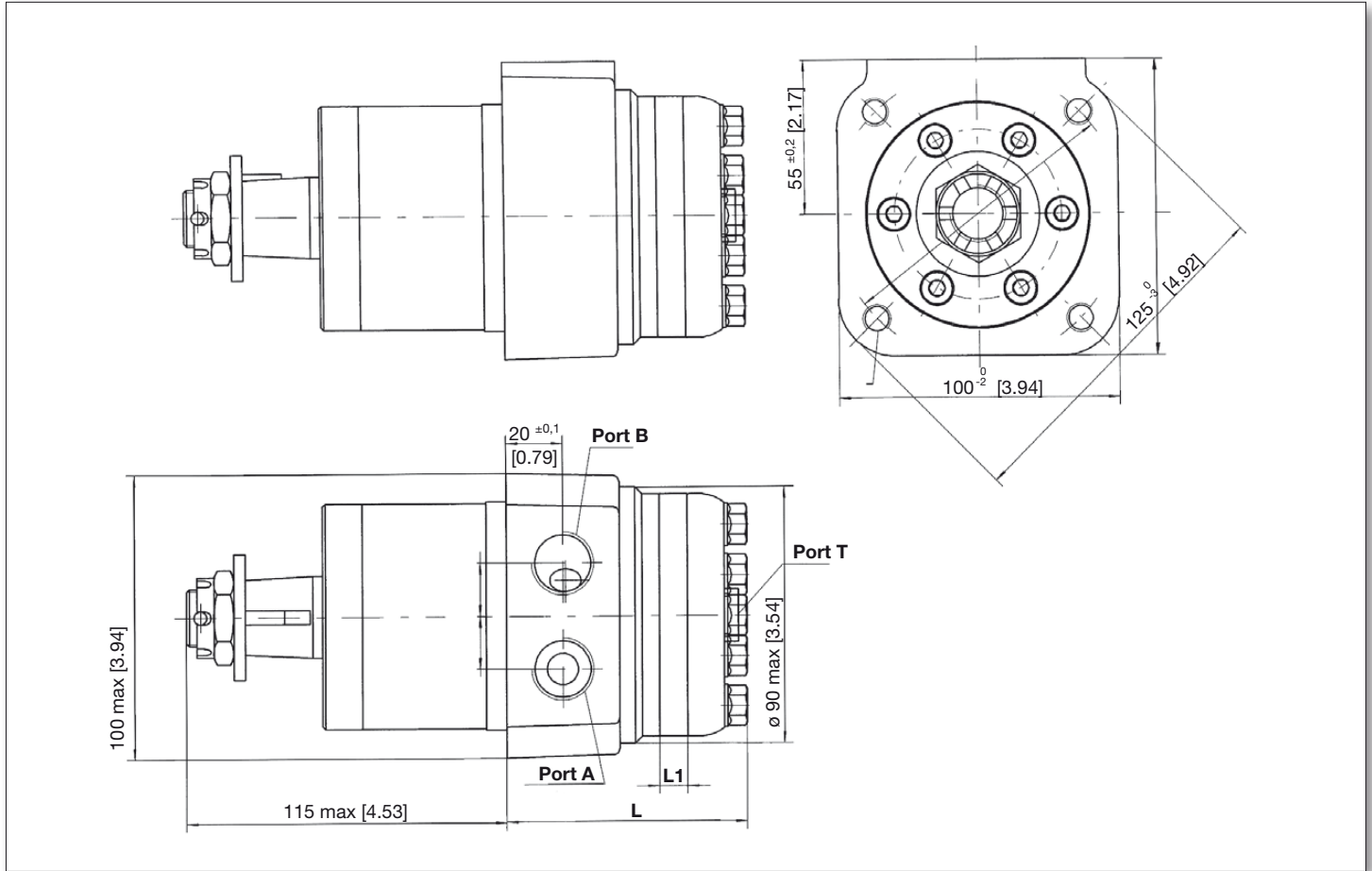

MODEL	[INCHES]		MILLIMETERS	
	L	L1	L	L1
YMPW 50	[3.19]	[.28]	81	7
YMPW 80	[3.33]	[0.41]	84.5	10.5
YMPW 100	[3.43]	[0.51]	87	13
YMPW 125	[3.54]	[0.63]	90	16
YMPW 160	[3.74]	[0.83]	95	21
YMPW 200	[3.94]	[1.02]	100	26
YMPW 250	[4.17]	[1.26]	106	32
YMPW 315	[4.57]	[1.65]	116	42
YMPW 400	[4.96]	[2.05]	126	52

### PORT & DRAIN PORT ORDERING CODES

ORDER CODE	G	DEPTH	S	DEPTH
PORTS A and B	G 1/2	15 mm	7/8-14 O-RING	17 mm
TANK PORT - T	G 1/4	12 mm	7/16 20UNF	12 mm

## MOTOR SHAFT EXTENSIONS

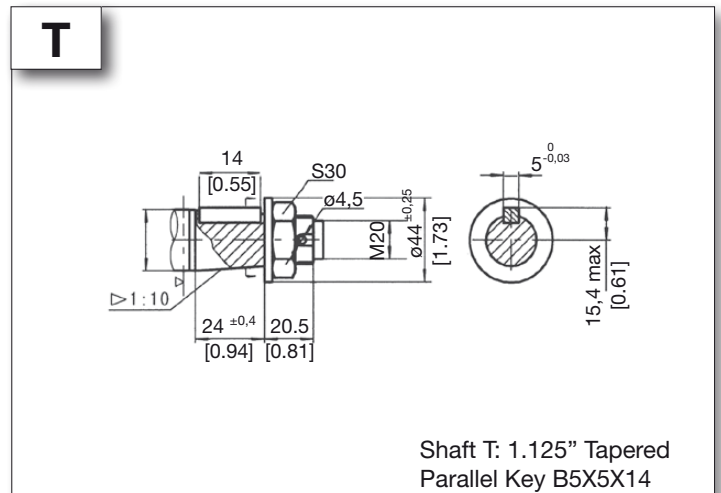
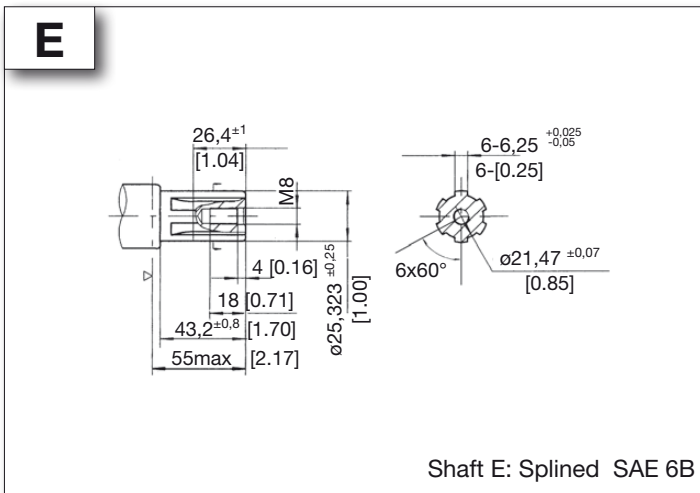
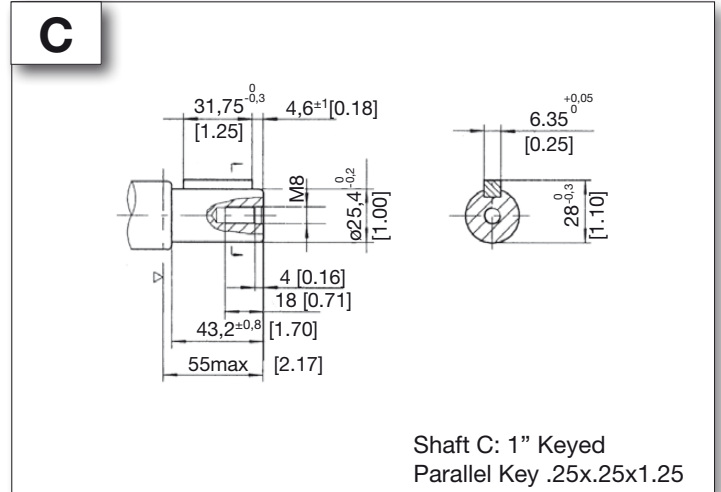
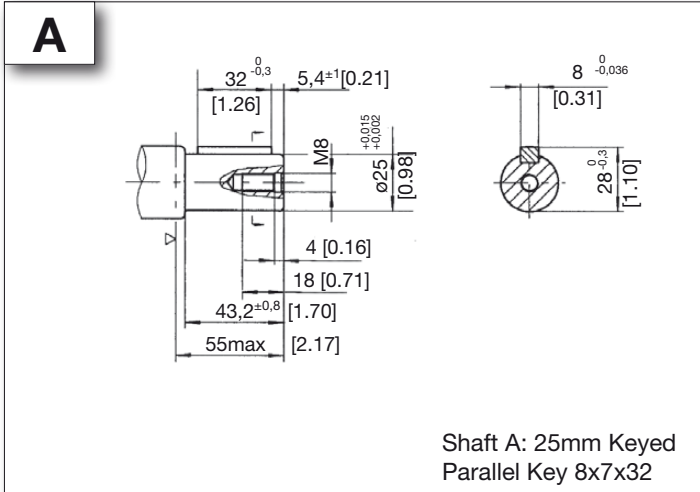

## ADDITIONAL INFORMATION

### PERMISSIBLE SHAFT SEAL PRESSURE

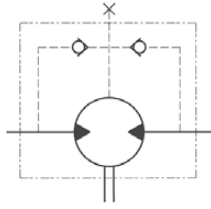

Note: Curve 1 for standard shaft seal  
Curve 2 for high pressure shaft seal

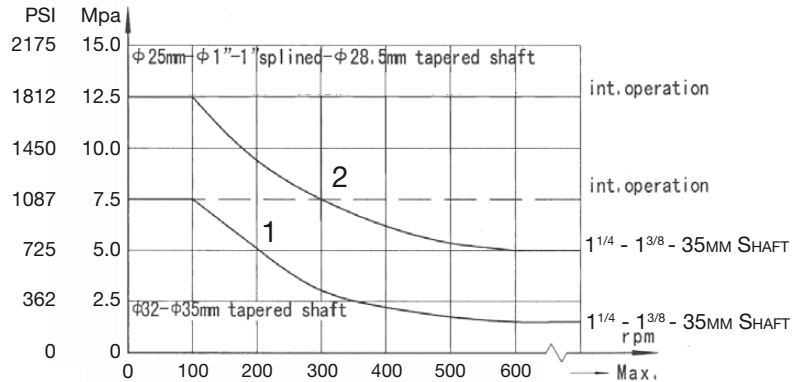

When viewing the motor from the output shaft end, port A is defined to be on the right and port B is defined to be on the left side. Standard rotation motors rotate CW when port A is pressurized. The motors are bi-directional and CCW rotation occurs when port B is pressurized.

Reverse rotation motors can special ordered which will operate with opposite rotation outlined above.

### SHAFT ROTATION DIRECTION

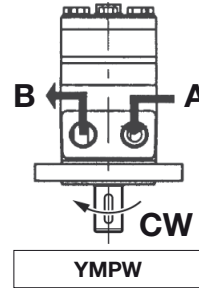

### LOAD CHART RATINGS

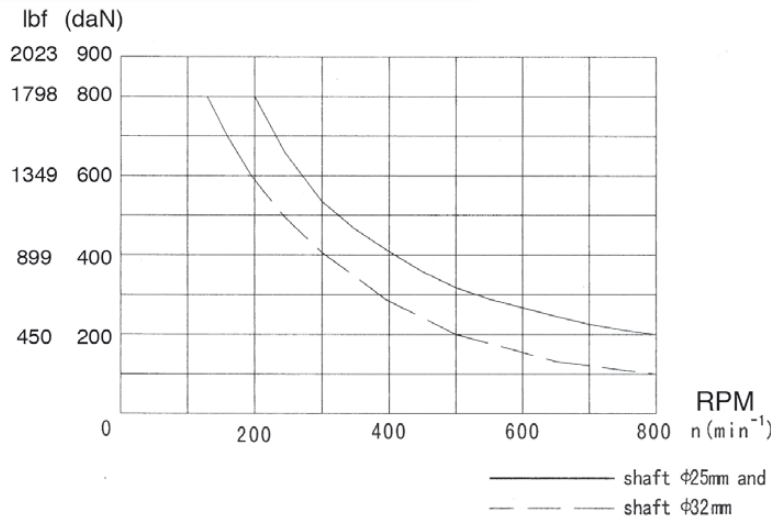

$$F_r = \frac{800 \cdot 2500}{n \cdot 95 + 1} \text{ daN}$$

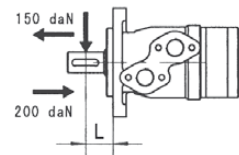

$F_r$  =Radial Force (.daN)  
 $L$  =Distance (mm)  
 $n$  =Speed (rpm)

Rhomb-flange  $L=30\text{mm}$   
Square-flange  $L=24\text{mm}$

— shaft  $\phi 25\text{mm}$  and  $\phi 1"$  ( $\phi 25.4\text{mm}$ )  
- - - shaft  $\phi 32\text{mm}$



## ORDERING INFORMATION

	<b>1</b>	<b>2</b>	<b>3</b>	<b>4</b>	<b>5</b>	<b>6</b>	<b>7</b>
<b>YMPW</b>							

1	2		3		4		5		6		7				
DISP.	FLANGE		OUTPUT SHAFT		PORT AND DRAIN PORT		ROTATION DIRECTION		PAINT		SPECIAL OPTIONS				
50	<b>OMIT</b>	Wheel Flange Pilot 80mmx7.5 4- m10 bolt holes	<b>A</b>	Shaft: 25mm Keyed Parallel Key 8x7x32	<b>G</b>	G 1/2,G 1/4	<b>NONE</b>	STANDARD	<b>00</b>	NO PAINT	<b>NONE</b>	STANDARD			
80			<b>C</b>	Shaft: 1" Keyed Parallel Key .25x.25x1.25								<b>R</b>	REVERSE	<b>B</b>	BLACK
100			<b>E</b>	Shaft: 1" SAE 6B Splined	<b>S</b>	7/8-14 O-ring , 7/16-20 UNF	<b>LL</b>	LOW LEAKAGE VALVE							
125			<b>T</b>	Shaft: 1.125 Tapered Parallel Key B5x5x14				<b>LSV</b>	LOW SPEED VALVE						
160									<b>CRS</b>	CORROSION RESISTANT SHAFT					
200										<b>HPS</b>	HIGH PRESSURE SEAL				
250					<b>HTS</b>	HIGH TEMP SEAL									
315															
400															

**ORDERING CODE:**

All options have been determined with letters, numbers or combinations. All boxes must be filled with proper codes. If specification is not in the table, please contact us with your requirements.



# YMR



The **YMR** series motor uses the **spool valve** shaft distribution design for simplicity, efficiency and compactness. This design integrates the distribution and hydraulic bearing design with the motor shaft.

This series uses the more advanced “**ROLLER**” gear type. It is manufactured with the most advanced technology and equipment to improve efficiency, smoothness, lower leakage and better overall performance.

These motors are very compact, economical, and powerful without the need of a reducer to deliver high torque.

The large number of shaft, flange, port and special options make this a very flexible motor useful for many applications.

## SPECIFICATIONS

Distribution Type	Model	Displacement		Max. Operating Pressure		Speed Range Continuous	Max. Output Power	
		[in <sup>3</sup> ./rev]	[3.05 ~ 22.88]	[PSI]	[2900]		[HP]	[20]
Spool Valve Distribution	YMR	cm <sup>3</sup> /rev.	50 ~ 375	MPa	20	30 ~ 970	Kw	15

## QUICK REFERENCE GUIDE

### YMR SERIES QUICK REFERENCE:

Displacements				
[in <sup>3</sup> /rev]	cm <sup>3</sup> /rev.			
[3.13]	51.3	FLOW UP TO	75 LPM	[20 GPM]
[4.92]	80.6	PRESSURE UP TO	20 MPa	[2900 PSI]
[6.15]	100.8	TORQUE UP TO	548 Nm	[4846 lb.-in.]
[7.62]	124.9	POWER UP TO	17 Kw	[23 HP]
[9.59]	157.2	SPEED UP TO	970 RPM	
[12.16]	199.2			
[15.38]	252			
[19.19]	314.5			
[22.58]	370			

**Shaft Seals:** Standard high pressure shaft seals permit applications in series or without drain line when required

**Low Speed Valving:** These motors are manufactured following strict procedures to reduce tolerances between all components to permit lower speed, higher efficiency and smoother rotation at very low speeds. These motors are not for high speed or low pressure applications.

**Free Running:** Motors with this option have increased clearances in the rotor set. This allows improved mechanical efficiency, longer life and better performance for high-speed / high-flow applications, winch or similar applications where the motor is cross-ported to allow manual free turning also remay benefit from this option to allow smoother easier free turning of the motor. Last, applications which have many reversals or high pressure spikes can also benefit since the pressure spikes will be reduced by relieving (cross-porting) such spikes internally in the motor. The trade off of these benefits is a slight reduction in volumetric efficiency, particularly at high pressure conditions.

**Special Motors:** These motors have special options like nickel plated shafts or housings for applications in corrosive environments.

### APPLICATION GUIDELINES:

For optimum results the following working conditions are recommended:

- \* Oil temperature should be between 20° - 60° C [68° - 180° F]
- \* Oil filter of 10 - 20 micron
- \* Oil viscosity 42 - 74 mm<sup>2</sup>/s CSA at 40° C
- \* Different shafts are used when there is a radial load or not. Check data pages
- \* For longer life we suggest the motor at start up, run for a shorter period of time (one hour) at no more than 30% of rated speed and pressure.

## SPECIFICATION DATA

DISTRIBUTION TYPE		YMR 50	YMR 80	YMR 100	YMR 125	YMR 160	YMR 200	YMR 250	YMR 315	YMR 375	
GEOMETRIC DISPLACEMENT	[in <sup>3</sup> /rev.]	[3.13]	[4.92]	[6.15]	[7.62]	[9.59]	[12.16]	[15.38]	[19.19]	[22.58]	
	cm <sup>3</sup> /rev.	<b>51.3</b>	<b>80.6</b>	<b>100.8</b>	<b>124.9</b>	<b>157.2</b>	<b>199.2</b>	<b>252</b>	<b>314.5</b>	<b>370</b>	
MAX. SPEED RPM	CONT.	<b>970</b>	<b>940</b>	<b>750</b>	<b>600</b>	<b>470</b>	<b>375</b>	<b>300</b>	<b>240</b>	<b>200</b>	
MAX. TORQUE [LB. IN.] N*M	CONT.	[LB. IN.]	[884]	[1680]	[2123]	[2582]	[3210]	[3166]	[3113]	[3184]	[3714]
		N*M	<b>100</b>	<b>190</b>	<b>240</b>	<b>292</b>	<b>363</b>	<b>358</b>	<b>352</b>	<b>360</b>	<b>420</b>
	INT.	[LB. IN.]	[1114]	[1946]	[2476]	[3007]	[3803]	[3962]	[4157]	[4157]	[4847]
		N*M	<b>126</b>	<b>220</b>	<b>280</b>	<b>340</b>	<b>430</b>	<b>448</b>	<b>470</b>	<b>470</b>	<b>548</b>
MAX. OUTPUT [HP] KW	CONT.	[HP]	[10]	[20]	[20]	[19]	[19]	[15]	[12]	[9]	[12]
		KW	<b>7.7</b>	<b>15</b>	<b>15</b>	<b>14</b>	<b>14</b>	<b>11</b>	<b>9</b>	<b>7</b>	<b>8.6</b>
	INT.	[HP]	[13]	[23]	[23]	[22]	[22]	[19]	[16]	[12]	[16]
		KW	<b>9.7</b>	<b>17</b>	<b>17</b>	<b>16</b>	<b>16</b>	<b>14</b>	<b>12</b>	<b>9</b>	<b>12</b>
MAX. PRES- SURE DROP [PSI] MP <sub>A</sub>	CONT.	[PSI]	[2030]	[2537]	[2537]	[2537]	[2392]	[1885]	[1595]	[1232]	[1232]
		MP <sub>A</sub>	<b>14</b>	<b>17.5</b>	<b>17.5</b>	<b>17.5</b>	<b>16.5</b>	<b>13</b>	<b>11</b>	<b>8.5</b>	<b>8.5</b>
	INT.	[PSI]	[2537]	[2900]	[2900]	[2900]	[2900]	[2537]	[2030]	[1667]	[1667]
		MP <sub>A</sub>	<b>17.5</b>	<b>20</b>	<b>20</b>	<b>20</b>	<b>20</b>	<b>17.5</b>	<b>14</b>	<b>11.5</b>	<b>11.5</b>
MAX. FLOW [GPM] L/MIN	CONT.	[GPM]	[10.6]	[15.8]	[15.8]	[15.8]	[15.8]	[15.8]	[15.8]	[15.8]	[15.8]
		L/MIN	<b>40</b>	<b>60</b>	<b>60</b>	<b>60</b>	<b>60</b>	<b>60</b>	<b>60</b>	<b>60</b>	<b>60</b>
	INT.	[GPM]	[13.2]	[19.8]	[19.8]	[19.8]	[19.8]	[19.8]	[19.8]	[19.8]	[19.8]
		L/MIN	<b>50</b>	<b>75</b>	<b>75</b>	<b>75</b>	<b>75</b>	<b>75</b>	<b>75</b>	<b>75</b>	<b>75</b>
WEIGHT [LB] KG	[LB]	[15]	[15]	[15]	[16]	[17]	[18]	[19]	[20]	[20]	
	KG	<b>6.7</b>	<b>6.9</b>	<b>6.9</b>	<b>7.2</b>	<b>7.5</b>	<b>8</b>	<b>8.5</b>	<b>9</b>	<b>9.3</b>	

- \* Continuous pressure:
- \* Intermittent pressure:
- \* Peak pressure:

Max. value of operating motor continuously.  
 Max. value of operating motor in 6 seconds per minute.  
 Max. value of operating motor in 0.6 second per minute.

## PERFORMANCE DATA

YMR 50 [3.13 in<sup>3</sup>/rev] 51.3 cm<sup>3</sup>/rev.

		[725]	[1015]	[1305]	[1450]	[1740]	[2030]	[2320]	[2537]	[PSI]
		5	7	9	10	12	14	16	17.5	MPa
GPM	[1.3]	[310]	[398]	[539]	[593]	[681]	[778]			
	5	35	45	61	67	77	88			
L/min	[2.6]	[318]	[407]	[548]	[610]	[708]	[840]	[955]	[1061]	TORQUE [LB-IN]
	10	36	46	62	69	80	95	108	120	TORQUE (N•M)
Flow (L/min)	[3.9]	[310]	[433]	[557]	[646]	[778]	[884]	[964]	[1088]	SPEED (RPM)
	15	35	49	63	73	88	100	109	123	
Flow (L/min)	[5.3]	[305]	[416]	[539]	[610]	[734]	[849]	[964]	[1114]	
	20	34.5	47	61	69	83	96	109	126	
Flow (L/min)	[6.6]	[301]	[398]	[539]	[610]	[716]	[849]	[964]	[1114]	
	25	34	45	61	69	81	96	109	126	
Flow (L/min)	[7.9]	[292]	[389]	[531]	[593]	[708]	[840]	[955]	[1114]	
	30	33	44	60	67	80	95	108	126	
Flow (L/min)	[9.2]	[274]	[371]	[522]	[584]	[708]	[822]	[946]	[1097]	
	35	31	42	59	66	80	93	107	124	
Max cont.	[10.6]	[265]	[363]	[513]	[584]	[699]	[814]	[937]	[1079]	Max cont.
Max int.	[11.9]	[261]	[354]	[504]	[575]	[690]	[796]	[929]	[1070]	Max int.
	45	29.5	40	57	65	78	90	105	121	

YMR 80 [4.92 in<sup>3</sup>/rev] 80.6 cm<sup>3</sup>/rev.

		[725]	[1015]	[1305]	[1450]	[1740]	[2030]	[2320]	[2537]	[PSI]
		5	7	9	10	12	14	16	17.5	MPa
GPM	[2.6]	[486]	[681]	[867]	[946]	[1150]	[1318]	[1503]	[1592]	
	10	55	77	98	107	130	149	170	180	
L/min	[5.3]	[442]	[722]	[929]	[1044]	[1167]	[1415]	[1574]	[1671]	TORQUE [LB-IN]
	20	50	81.6	105	118	132	160	178	189	TORQUE (N•M)
Flow (L/min)	[7.9]	[425]	[654]	[858]	[1008]	[1159]	[1327]	[1584]	[1680]	SPEED (RPM)
	30	48	74	97	114	131	150	179	190	
Flow (L/min)	[10.6]	[398]	[628]	[840]	[929]	[1132]	[1318]	[1565]	[1663]	
	40	45	71	95	105	128	149	177	188	
Flow (L/min)	[13.2]	[371]	[619]	[796]	[867]	[1106]	[1300]	[1512]	[1654]	
	50	42	70	90	98	125	147	171	187	
Flow (L/min)	[15.8]	[336]	[557]	[752]	[840]	[1044]	[1256]	[1495]	[1636]	
	60	38	63	85	95	118	142	169	185	
Max cont.	[18.5]	[318]	[513]	[708]	[787]	[991]	[1229]	[1450]	[1583]	Max cont.
Max int.	[19.8]	[256]	[495]	[681]	[751]	[973]	[1176]	[1424]	[1565]	Max int.
	75	29	56	77	85	110	133	161	177	

YMR 100 [6.15 in<sup>3</sup>/rev] 100.8 cm<sup>3</sup>/rev

		[725]	[1015]	[1305]	[1450]	[1740]	[2030]	[2320]	[2537]	[PSI]
		5	7	9	10	12	14	16	17.5	MPa
GPM	[2.6]	[619]	[884]	[1079]	[1220]	[1406]	[1610]	[1857]	[1963]	
	10	70	100	122	138	159	182	210	222	
L/min	[5.3]	[601]	[840]	[1088]	[1265]	[1459]	[1769]	[1955]	[2105]	TORQUE [LB-IN]
	20	68	95	123	143	165	200	221	238	TORQUE (N•M)
Flow (L/min)	[7.9]	[548]	[831]	[1070]	[1238]	[1450]	[1716]	[1946]	[2123]	SPEED (RPM)
	30	62	94	121	140	164	194	220	240	
Flow (L/min)	[10.6]	[522]	[778]	[1052]	[1185]	[1424]	[1698]	[1928]	[2105]	
	40	59	88	119	134	161	192	218	238	
Flow (L/min)	[13.2]	[486]	[734]	[1035]	[1106]	[1389]	[1636]	[1919]	[2078]	
	50	55	83	117	125	157	185	217	235	
Flow (L/min)	[15.8]	[425]	[699]	[973]	[1052]	[1344]	[1592]	[1893]	[2061]	
	60	48	79	110	119	152	180	214	233	
Flow (L/min)	[18.5]	[380]	[619]	[884]	[991]	[1256]	[1503]	[1778]	[2025]	
	70	43	70	100	112	142	170	201	229	
Max cont.	[19.8]	[345]	[557]	[858]	[929]	[1238]	[1477]	[1742]	[2008]	Max cont.
Max int.	[19.8]	[345]	[557]	[858]	[929]	[1238]	[1477]	[1742]	[2008]	Max int.
	75	39	63	97	105	140	167	197	227	

YMR 125 [7.62 in<sup>3</sup>/rev] 124.9 cm<sup>3</sup>/rev.

		[725]	[1015]	[1305]	[1450]	[1740]	[2030]	[2320]	[2537]	[PSI]
		5	7	9	10	12	14	16	17.5	MPa
GPM	[2.6]	[796]	[1079]	[1415]	[1530]	[1813]	[2096]	[2282]	[2388]	
	10	90	122	160	173	205	237	258	270	
L/min	[5.3]	[752]	[1044]	[1046]	[1521]	[1840]	[2211]	[2459]	[2582]	TORQUE [LB-IN]
	20	85	118	159	172	208	250	278	292	TORQUE (N•M)
Flow (L/min)	[7.9]	[725]	[946]	[1397]	[1450]	[1822]	[2131]	[2450]	[2574]	SPEED (RPM)
	30	82	107	158	164	206	241	277	291	
Flow (L/min)	[10.6]	[699]	[929]	[1327]	[1424]	[1804]	[2105]	[2432]	[2556]	
	40	79	105	150	161	204	238	275	289	
Flow (L/min)	[13.2]	[663]	[849]	[1282]	[1415]	[1751]	[2087]	[2317]	[2494]	
	50	75	96	145	160	198	236	262	282	
Flow (L/min)	[15.8]	[548]	[840]	[1229]	[1397]	[1618]	[1963]	[2246]	[2467]	
	60	62	95	139	158	183	222	254	279	
Flow (L/min)	[18.5]	[522]	[734]	[1106]	[1327]	[1574]	[1875]	[2211]	[2317]	
	70	59	83	125	150	178	212	250	262	
Max cont.	[19.8]	[495]	[708]	[1079]	[1282]	[1521]	[1813]	[2167]	[2308]	Max cont.
Max int.	[19.8]	[495]	[708]	[1079]	[1282]	[1521]	[1813]	[2167]	[2308]	Max int.
	75	56	80	122	145	172	205	245	261	

## PERFORMANCE DATA

YMR 160 [9.59 in<sup>3</sup>/rev] 157.2 cm<sup>3</sup>/rev. Max cont. Max int.

	[725]	[1015]	[1305]	[1450]	[1740]	[2030]	[2320]	[2537]	[PSI]
	5	7	9	10	12	14	16	17.5	MPa
GPM	[2.6]	[1017]	[1415]	[1822]	[1946]	[2299]	[2653]	[3007]	[3202]
	L/min	115	160	203	220	260	300	340	362
Flow (L/min)	[5.3]	[1026]	[1415]	[1813]	[2034]	[2344]	[2830]	[3140]	[3361]
	20	116	160	205	230	265	320	355	380
Flow (L/min)	[7.9]	[929]	[1397]	[1786]	[1955]	[2308]	[2697]	[3042]	[3343]
	30	105	158	202	221	261	305	344	378
Flow (L/min)	[10.6]	[884]	[1282]	[1733]	[1928]	[2273]	[2644]	[3007]	[3308]
	40	100	145	196	218	257	299	340	374
Flow (L/min)	[13.2]	[796]	[1238]	[1680]	[1848]	[2211]	[2609]	[2972]	[3237]
	50	90	140	190	209	250	295	336	366
Flow (L/min)	[15.8]	[743]	[1203]	[1592]	[1760]	[2123]	[2529]	[2919]	[3184]
	60	84	136	180	199	240	286	330	360
Max cont.	[18.5]	[575]	[1061]	[1450]	[1592]	[1972]	[2476]	[2830]	[3095]
	70	65	120	164	180	223	280	320	350
Max int.	[19.8]	[522]	[1026]	[1397]	[1548]	[1946]	[2406]	[2777]	[3025]
	75	59	116	158	175	220	272	314	342

YMR 200 [9.59 in<sup>3</sup>/rev] 157.2 cm<sup>3</sup>/rev. Max cont. Max int.

	[725]	[1015]	[1305]	[1508]	[1740]	[2030]	[2537]	[PSI]
	5	7	9	10.5	12	14	17.5	MPa
GPM	[2.6]	[1309]	[1813]	[2255]	[2565]	[2892]	[3272]	[3909]
	L/min	148	205	255	290	327	370	442
Flow (L/min)	[5.3]	[1238]	[1786]	[2211]	[2857]	[2919]	[3635]	[3962]
	20	140	202	250	323	330	411	448
Flow (L/min)	[7.9]	[1150]	[1707]	[2131]	[2715]	[2874]	[3334]	[3936]
	30	130	193	241	307	325	377	445
Flow (L/min)	[10.6]	[1105]	[1645]	[2052]	[2697]	[2768]	[3449]	[3856]
	40	125	186	232	305	313	390	436
Flow (L/min)	[13.2]	[1061]	[1565]	[1990]	[2609]	[2697]	[3378]	[3776]
	50	120	177	225	295	305	382	427
Flow (L/min)	[15.8]	[973]	[1468]	[1954]	[2521]	[2582]	[3290]	[3706]
	60	110	166	221	285	292	372	419
Max cont.	[18.5]	[867]	[1327]	[1813]	[2158]	[2459]	[2927]	[3626]
	70	98	150	205	244	278	331	410
Max int.	[19.8]	[752]	[1247]	[1760]	[2078]	[2370]	[2857]	[3538]
	75	85	141	199	235	268	323	400

YMR 250 [15.38 in<sup>3</sup>/rev] 252 cm<sup>3</sup>/rev. Max cont. Max int.

	[435]	[725]	[1015]	[1160]	[1450]	[1595]	[2030]	[2537]	[PSI]
	3	5	7	8	10	11	14	17.5	MPa
GPM	[2.6]	[1017]	[1415]	[2220]	[2609]	[3095]	[3361]	[4157]	[4732]
	L/min	115	180	251	295	350	380	470	535
Flow (L/min)	[5.3]	[973]	[1574]	[2229]	[2600]	[3113]	[3405]	[4157]	[4847]
	20	110	178	252	294	352	385	470	548
Flow (L/min)	[7.9]	[884]	[1503]	[2193]	[2521]	[3078]	[3370]	[4148]	[4820]
	30	100	170	248	285	348	381	469	545
Flow (L/min)	[10.6]	[805]	[1406]	[2052]	[2370]	[2936]	[3237]	[4068]	[4687]
	40	91	159	232	268	332	366	460	530
Flow (L/min)	[13.2]	[716]	[1309]	[1910]	[2229]	[2830]	[3113]	[4006]	[4608]
	50	81	148	216	252	320	352	453	521
Flow (L/min)	[15.8]	[663]	[1167]	[1778]	[2078]	[2697]	[3007]	[3829]	[4466]
	60	75	132	201	235	305	340	433	505
Max cont.	[18.5]	[442]	[1035]	[1671]	[1946]	[2565]	[2830]	[3644]	[4378]
	70	50	117	189	220	290	320	412	495
Max int.	[19.8]	[371]	[929]	[1592]	[1866]	[2485]	[2742]	[3582]	[4298]
	75	42	105	180	211	281	310	405	486

YMR 315 [19.19 in<sup>3</sup>/rev] 314.5 cm<sup>3</sup>/rev. Max cont. Max int.

	[435]	[725]	[942]	[1160]	[1305]	[1885]	[1957]	[PSI]
	3	5	6.5	8	9	13	13.5	MPa
GPM	[2.6]	[1194]	[1901]	[2467]	[3033]	[3387]	[4555]	[4864]
	L/min	135	215	279	343	383	515	550
Flow (L/min)	[5.3]	[1176]	[1910]	[2556]	[3086]	[3361]	[4493]	[4882]
	20	133	216	289	349	380	508	552
Flow (L/min)	[7.9]	[1105]	[1813]	[2432]	[3016]	[3316]	[4369]	[4802]
	30	125	205	275	341	375	494	543
Flow (L/min)	[10.6]	[999]	[1724]	[2361]	[2963]	[3246]	[4289]	[4652]
	40	113	195	267	335	367	485	526
Flow (L/min)	[13.2]	[814]	[1503]	[2237]	[2839]	[3113]	[4192]	[4519]
	50	92	170	253	321	352	474	511
Flow (L/min)	[15.8]	[707]	[1415]	[2043]	[2697]	[2954]	[4050]	[4351]
	60	80	160	231	305	334	458	492
Max cont.	[18.5]	[504]	[1203]	[1901]	[2520]	[2830]	[3927]	[4245]
	70	57	136	215	285	320	444	480
Max int.	[19.8]	[486]	[1097]	[1813]	[2379]	[2724]	[3776]	[4148]
	75	55	124	205	269	308	427	469

## PERFORMANCE DATA

YMR 375 [22.58 in<sup>3</sup>/rev] 370 cm<sup>3</sup>/rev.

Max  
cont.

Max  
int.

	[435] 3	[725] 5	[942] 6.5	[1160] 8	[1305] 9	[1885] 13	[1957] 13.5	[PSI] MPa
GPM L/ min	[2.6] 10	[1415] 160 <b>26</b>	[2388] 270 <b>25</b>	[3007] 340 <b>24</b>	[3714] 420 <b>22</b>	[4157] 470 <b>21</b>	[4864] 550 <b>19</b>	[5395] 610 <b>17</b>
	[5.3] 20	[1406] 159 <b>53</b>	[2299] 260 <b>52</b>	[3007] 340 <b>51</b>	[3626] 410 <b>49</b>	[4157] 470 <b>47</b>	[4776] 540 <b>42</b>	[5351] 605 <b>37</b>
Flow (L/min)	[7.9] 30	[1327] 150 <b>79</b>	[1990] 225 <b>78</b>	[2918] 330 <b>77</b>	[3538] 400 <b>75</b>	[3980] 450 <b>73</b>	[4687] 530 <b>67</b>	[5306] 600 <b>60</b>
	[10.6] 40	[1194] 135 <b>106</b>	[2123] 240 <b>105</b>	[2742] 310 <b>104</b>	[3317] 375 <b>102</b>	[3803] 430 <b>99</b>	[4599] 520 <b>93</b>	[5218] 590 <b>85</b>
Max cont	[13.2] 50	[1061] 120 <b>134</b>	[2034] 230 <b>132</b>	[2609] 295 <b>131</b>	[3184] 360 <b>129</b>	[3714] 420 <b>126</b>	[4466] 505 <b>120</b>	[5041] 570 <b>110</b>
	[15.8] 60	[867] 98 <b>159</b>	[1857] 210 <b>158</b>	[2432] 275 <b>157</b>	[3007] 340 <b>155</b>	[3449] 390 <b>153</b>	[4334] 490 <b>147</b>	[4864] 550 <b>135</b>
Max int.	[18.5] 70	[663] 75 <b>187</b>	[1548] 175 <b>186</b>	[2211] 250 <b>185</b>	[2830] 320 <b>183</b>	[3272] 370 <b>180</b>	[4112] 465 <b>175</b>	[4687] 530 <b>160</b>
	[19.8] 75	[575] 65 <b>200</b>	[1415] 160 <b>199</b>	[2034] 230 <b>198</b>	[2742] 310 <b>195</b>	[3184] 360 <b>192</b>	[3980] 450 <b>187</b>	[4555] 515 <b>178</b>

TORQUE [LB-IN]  
TORQUE (N•M)  
SPEED (RPM)

Max  
cont.

Max  
int.



## DIMENSIONS AND MOUNTING DATA

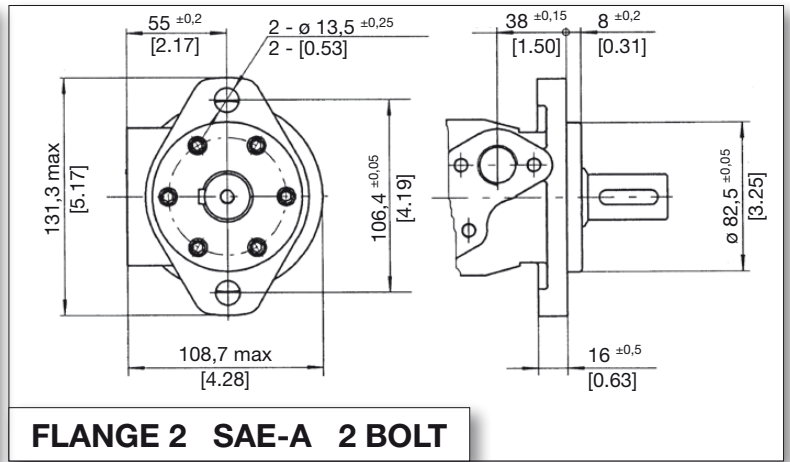
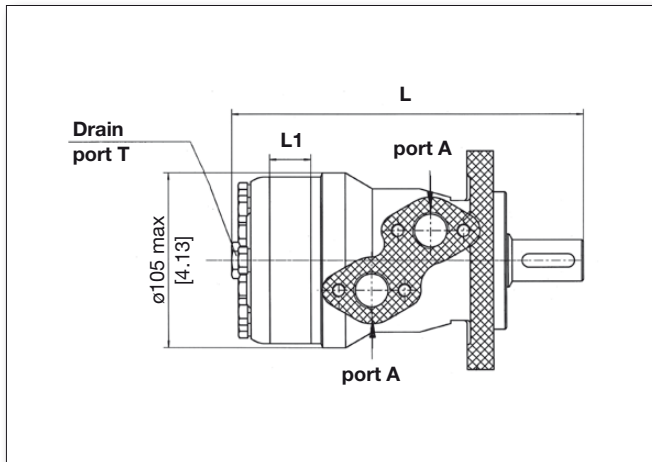

**FLANGE 2 SAE-A 2 BOLT**

MODEL	[INCHES]		MILLIMETERS	
	L	L1	L	L1
YMR 50	[5.51]	[0.39]	140	10
YMR 80	[5.75]	[0.63]	146	16
YMR 100	[5.91]	[0.79]	150	20
YMR 125	[6.10]	[0.98]	155	25
YMR 160	[6.36]	[1.24]	161.5	31.5
YMR 200	[6.69]	[1.57]	170	40
YMR 250	[7.09]	[1.97]	180	50
YMR 315	[7.56]	[2.44]	192	62
YMR 375	[8.03]	[2.91]	204	74

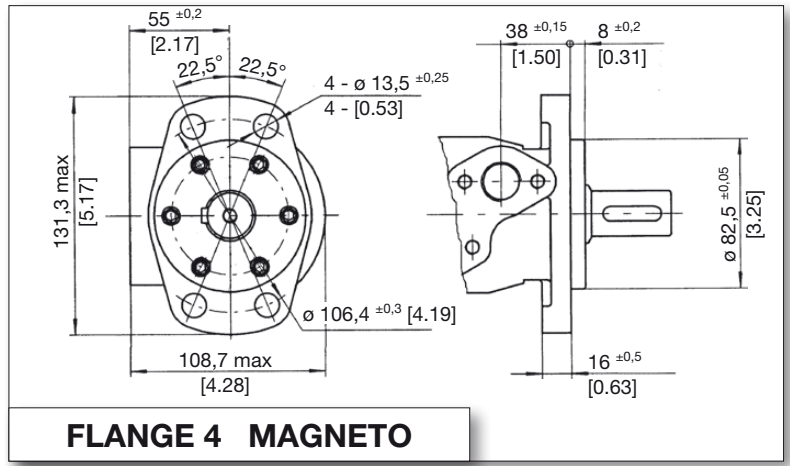

**FLANGE 4 MAGNETO**

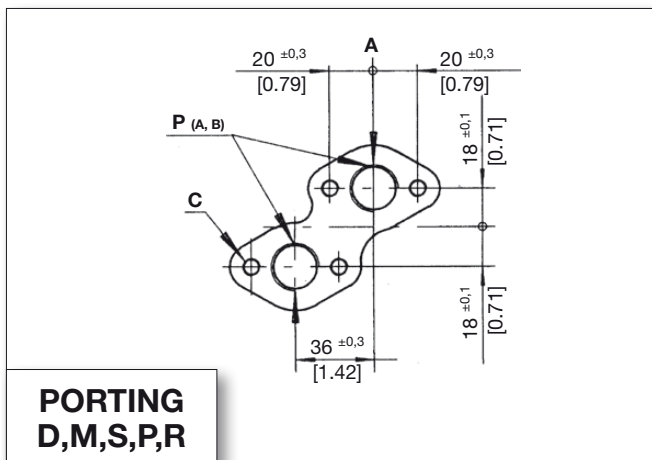

**PORTING  
D,M,S,P,R**

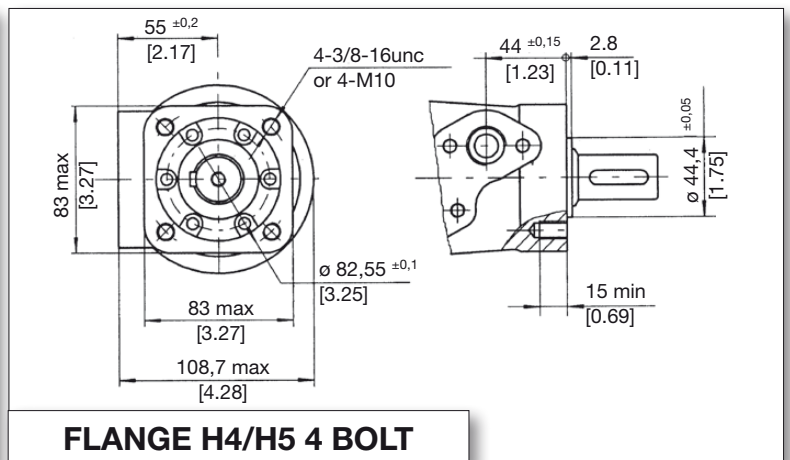

**FLANGE H4/H5 4 BOLT**

### PORT & DRAIN PORT ORDERING CODES

ORDER CODE	D	DEPTH	M	DEPTH	S	DEPTH	P	DEPTH	R	DEPTH
PORTS - A and B	G 1/2	15 mm	M22 X 1.5	15 mm	7/8-14 O-RING	17 mm	1/2-14NPTF	15 mm	PT(RC)1/2	15 mm
TANK PORT - T	G 1/4	12 mm	M14 X 1.5	12 mm	7/16-20UNF	12 mm	7/16-20UNF	12 mm	PT(RC)1/4	9.7 mm
BOLTS - C	4-M8	13 mm	4-M8	13 mm	4-5/16-18UNC	13 mm	4-5/16-18UNC	13 mm	4-M8	13 mm



## ADDITIONAL INFORMATION

### PERMISSIBLE SHAFT SEAL PRESSURE

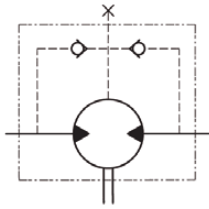

Note: Curve 1 for standard shaft seal  
Curve 2 for high pressure shaft seal

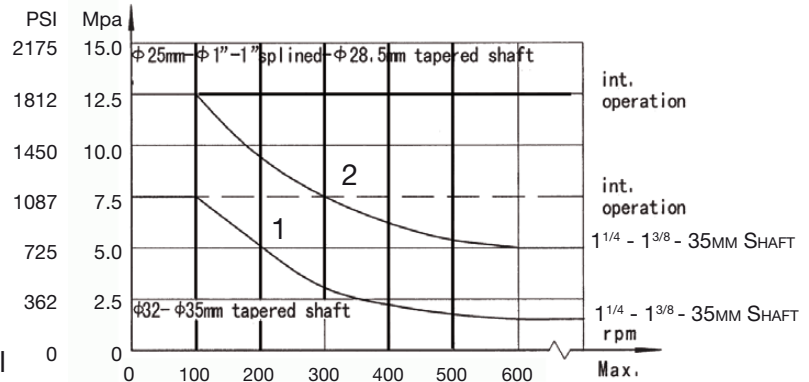

When viewing the motor from the output shaft end, port A is defined to be on the right and port B is defined to be on the left side. Standard rotation motors rotate CW when port A is pressurized. The motors are bi-directional and CCW rotation occurs when port B is pressurized.

Reverse rotation motors can special ordered which will operate with opposite rotation outlined above.

### SHAFT ROTATION DIRECTION

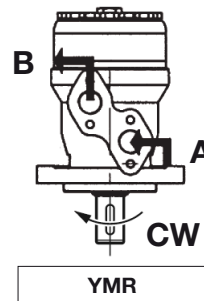

YMR

### STATUS OF THE SHAFT'S RADIAL FORCE

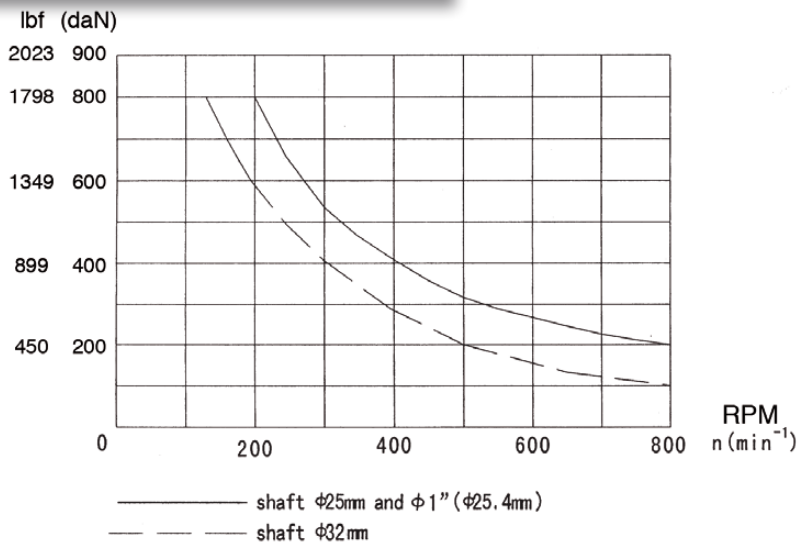

$$F_r = \frac{800 \cdot 2500}{n \cdot 95 + 1} \text{ daN}$$

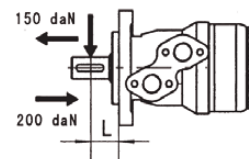

$F_r$  =Radial Force (daN)

$L$  =Distance (mm)

$n$  =Speed (rpm)

Rhomb-flange  $L=30\text{mm}$

Square-flange  $L=24\text{mm}$

## ORDER INFORMATION

	1	2	3	4	5	6	7
YMR							

1	2	3	4	5	6	7
DISP.	FLANGE	OUTPUT SHAFT	PORT AND DRAIN PORT	ROTATION DIRECTION	PAINT	SPECIAL OPTIONS
50	2 SAE - A 2 Bolt Pilot .25"x0.31"	A Shaft 25mm Keyed Parallel key 8x7x32	D G1/2 Manifold Mount 4xM8, G1/4	NONE STANDARD	00 NO PAINT	NONE STANDARD
80	4 4 Bolt Magneto Pilot .25"x0.31"	B Shaft 32mm Keyed Parallel key 10x8x45	M M22x1.5 Manifold Mount 4xM8, M14x1.5	R OPPOSITE		N NEEDLE BEARING
100	H4 4 Bolt Flange Pilot 1.75"x0.11" 4 bolts: 3/8 - 16UNC	C Shaft 1" keyed Parallel key 25"x0.25"x1.25"	S 7/8-14 O-ring manifold 4x5/16-18UNC, 7/16-20UNF		B BLACK	
125	H5 4 Bolt Flange Pilot Ø44.4x2.8 4 x M10	E Splined SAE 6B	P 1/2-14 NPTF Manifold 4x5/16-18UNC, 7/16-20UNF			
160		R Short shaft 1" Keyed Parallel key 25"x0.25"x1.25"	R PT(Rc)1/2 Manifold 4xM8, PT(Rc)1/4			FR FREE RUNNING
200		F 1 1/4" 14 Splined 14-DP12/24				
250		FD Long - 1 1/4" 14 Splined 14-DP12/24				LSV LOW SPEED VALVE
315		G 1 1/4" keyed Parallel key 31"x0.31"x1.25"				CRS CORROSION RESISTANT SHAFT
375		T 1 1/8" Tapered Parallel key B5X5X14				HPS HIGH PRESSURE SEAL
						HTS HIGH TEMP SEAL

**ORDERING CODE:**

All options have been determined with letters, numbers or combinations. All boxes must be filled with proper codes. If specification is not in the table, please contact us with your requirements.

# YMRS



The **YMRS** series motor uses the **spool valve** shaft distribution design for simplicity, efficiency and compactness. This design integrates the distribution and hydraulic bearing design with the motor shaft.

This series uses the more advanced “**ROLLER**” gear type. It is manufactured with the most advanced technology and equipment to improve efficiency, smoothness, lower leakage and better overall performance.

This design has identical displacements and performance of the YMR series with a few different options.

These motors are very compact, economical, and powerful without the need of a reducer to deliver high torque.

The large number of shaft, flange, port and special options make this a very flexible motor useful for many applications.

## SPECIFICATIONS

Distribution Type	Model	Displacement		Max. Operating Pressure		Speed Range Continuous	Max. Output Power	
		[in <sup>3</sup> ./rev]	[3.05 ~ 22.88]	[PSI]	[2900]		[HP]	[20]
Axial Distribution	YMRS	cm <sup>3</sup> /rev.	50 ~ 375	MPa	20	30 ~ 970	Kw	15

## QUICK REFERENCE GUIDE

### YMRS SERIES QUICK REFERENCE:

Displacements				
[in <sup>3</sup> /rev]	cm <sup>3</sup> /rev.			
[3.13]	51.3	FLOW UP TO	75 LPM	[20 GPM]
[4.92]	80.6	PRESSURE UP TO	20 MPa	[2900 PSI]
[6.15]	100.8	TORQUE UP TO	548 Nm	[4846 in.-lb.]
[7.62]	124.9	POWER UP TO	17 Kw	[23 HP]
[9.59]	157.2	SPEED UP TO	970 RPM	
[12.16]	199.2			
[15.38]	252			
[19.19]	314.5			
[22.58]	370			

**Shaft Seals:** Standard high pressure shaft seals permit applications in series or without drain line when required

**Low Speed Valving:** These motors are manufactured following strict procedures to reduce tolerances between all components to permit lower speed, higher efficiency and smoother rotation at very low speeds. These motors are not for high speed or low pressure applications.

**Free Running:** Motors with this option have increased clearances in the rotor set. This allows improved mechanical efficiency, longer life and better performance for high-speed / high-flow applications, winch or similar applications where the motor is cross-ported to allow manual free turning also remain benefit from this option to allow smoother easier free turning of the motor. Last, applications which have many reversals or high pressure spikes can also benefit since the pressure spikes will be reduced by relieving (cross-porting) such spikes internally in the motor. The trade off of these benefits is a slight reduction in volumetric efficiency, particularly at high pressure conditions.

**Special Motors:** These motors have special options like nickel plated shafts or housings for applications in corrosive environments.

### APPLICATION GUIDELINES:

For optimum results the following working conditions are recommended:

- \* Oil temperature should be between 20° - 60° C [68° - 180° F]
- \* Oil filter of 10 - 20 micron
- \* Oil viscosity 42 - 74 mm<sup>2</sup>/s CSA at 40° C
- \* Different shafts are used when there is a radial load or not. Check data pages
- \* For longer life we suggest the motor at start up, run for a shorter period of time (one hour) at no more than 30% of rated speed and pressure.

## SPECIFICATION DATA

For individual motor performance chart consult equivalent YMR series data

DISTRIBUTION TYPE		YMRS 50	YMRS 80	YMRS 100	YMRS 125	YMRS 160	YMRS 200	YMRS 250	YMRS 315	YMRS 375	
GEOMETRIC DISPLACEMENT	[in <sup>3</sup> /rev.]	[3.13]	[4.92]	[6.15]	[7.62]	[9.59]	[12.16]	[15.38]	[19.19]	[22.58]	
	cm <sup>3</sup> /rev.	<b>51.3</b>	<b>80.6</b>	<b>100.8</b>	<b>124.9</b>	<b>157.2</b>	<b>199.2</b>	<b>252</b>	<b>314.5</b>	<b>370</b>	
MAX. SPEED RPM	CONT.	<b>970</b>	<b>940</b>	<b>750</b>	<b>600</b>	<b>470</b>	<b>375</b>	<b>300</b>	<b>240</b>	<b>200</b>	
MAX. TORQUE [LB.IN.] N*M	CONT.	[LB.IN.]	[884]	[1680]	[2123]	[2582]	[3210]	[3166]	[3113]	[3184]	[3714]
		N*M	<b>100</b>	<b>190</b>	<b>240</b>	<b>292</b>	<b>363</b>	<b>358</b>	<b>352</b>	<b>360</b>	<b>420</b>
	INT.	[LB.IN.]	[1114]	[1946]	[2476]	[3007]	[3803]	[3962]	[4157]	[4157]	[4847]
		N*M	<b>126</b>	<b>220</b>	<b>280</b>	<b>340</b>	<b>430</b>	<b>448</b>	<b>470</b>	<b>470</b>	<b>548</b>
MAX. OUTPUT [HP] KW	CONT.	[HP]	[10]	[20]	[20]	[19]	[19]	[15]	[12]	[9]	[12]
		KW	<b>7.7</b>	<b>15</b>	<b>15</b>	<b>14</b>	<b>14</b>	<b>11</b>	<b>9</b>	<b>7</b>	<b>8.6</b>
	INT.	[HP]	[13]	[23]	[23]	[22]	[22]	[19]	[16]	[12]	[16]
		KW	<b>9.7</b>	<b>17</b>	<b>17</b>	<b>16</b>	<b>16</b>	<b>14</b>	<b>12</b>	<b>9</b>	<b>12</b>
MAX. PRESSURE DROP [PSI] MPa	CONT.	[PSI]	[2030]	[2537]	[2537]	[2537]	[2392]	[1885]	[1595]	[1232]	[1232]
		MPa	<b>14</b>	<b>17.5</b>	<b>17.5</b>	<b>17.5</b>	<b>16.5</b>	<b>13</b>	<b>11</b>	<b>8.5</b>	<b>8.5</b>
	INT.	[PSI]	[2538]	[2900]	[2900]	[2900]	[2900]	[2537]	[2030]	[1667]	[1667]
		MPa	<b>17.5</b>	<b>20</b>	<b>20</b>	<b>20</b>	<b>20</b>	<b>17.5</b>	<b>14</b>	<b>11.5</b>	<b>11.5</b>
MAX. FLOW [GPM] L/MIN	CONT.	[GPM]	[10.6]	[15.8]	[15.8]	[15.8]	[15.8]	[15.8]	[15.8]	[15.8]	[15.8]
		L/MIN	<b>40</b>	<b>60</b>	<b>60</b>	<b>60</b>	<b>60</b>	<b>60</b>	<b>60</b>	<b>60</b>	<b>60</b>
	INT.	[GPM]	[13.2]	[19.8]	[19.8]	[19.8]	[19.8]	[19.8]	[19.8]	[19.8]	[19.8]
		L/MIN	<b>50</b>	<b>75</b>	<b>75</b>	<b>75</b>	<b>75</b>	<b>75</b>	<b>75</b>	<b>75</b>	<b>75</b>
WEIGHT [LB] KG	[LB]	[15]	[15]	[15]	[16]	[17]	[18]	[19]	[20]	[20]	
	KG	<b>6.7</b>	<b>6.9</b>	<b>6.9</b>	<b>7.2</b>	<b>7.5</b>	<b>8</b>	<b>8.5</b>	<b>9</b>	<b>9.3</b>	

- \* Continuous pressure: Max. value of operating motor continuously.
- \* Intermittent pressure: Max. value of operating motor in 6 seconds per minute.
- \* Peak pressure: Max. value of operating motor in 0.6 second per minute.

## DIMENSIONS AND MOUNTING DATA

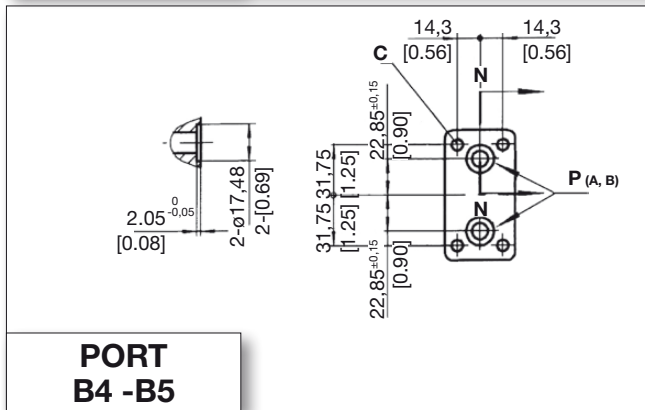
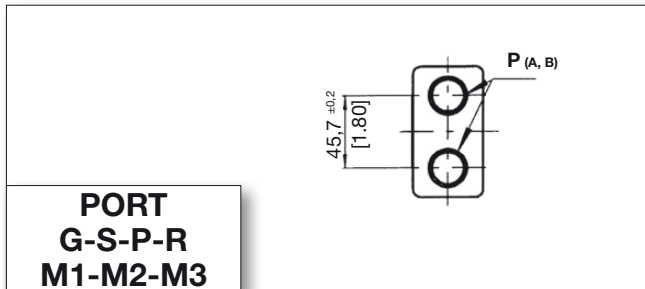
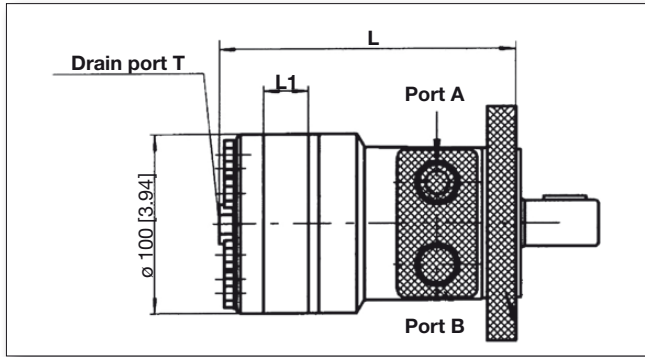

MODEL	[INCHES]		MILLIMETERS	
	L	L1	L	L1
YMRS 50	[5.67]	[0.39]	144	10
YMRS 80	[5.91]	[0.63]	150	16
YMRS 100	[6.06]	[0.79]	154	20
YMRS 125	[6.26]	[0.98]	159	25
YMRS 160	[6.12]	[1.24]	155.5	31.5
YMRS 200	[6.85]	[1.57]	174	40
YMRS 250	[7.24]	[1.97]	184	50
YMRS 315	[7.72]	[2.44]	196	62
YMRS 375	[8.19]	[2.91]	208	74

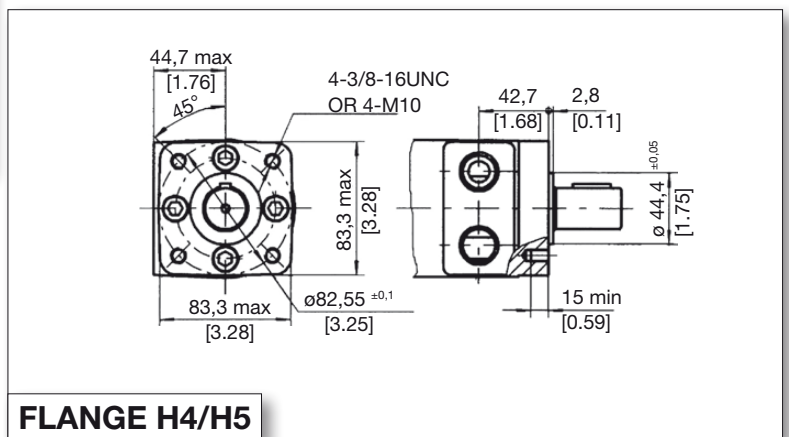
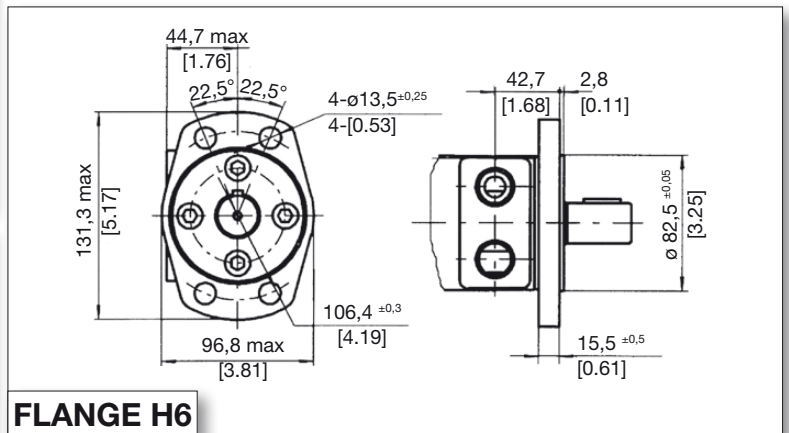
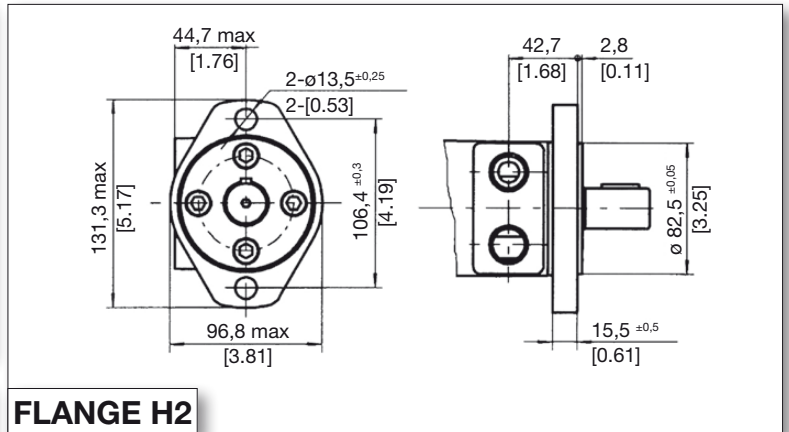

### PORT & DRAIN PORT ORDERING CODES

ORDER CODE	G	DEPTH	S	DEPTH	P	DEPTH	R	DEPTH	M1	DEPTH	M2	DEPTH	M3	DEPTH	B4	DEPTH	B5	DEPTH
PORTS A and B	G 1/2	15 mm	7/8-14 O-RING	17 mm	1/2 14NPTF	15 mm	PT(RC) 1/2	15 mm	M18 X 1.5	15 mm	M20 X 1.5	15 mm	M22 X 1.5	15 mm	Ø10	-	Ø10	-
TANK PORT T	G 1/4	12 mm	7/16 20UNF	12 mm	7/16 20UNF	12 mm	PT(RC) 1/4	9.7 mm	M10 X 1	12 mm	M10 X 1	12 mm	M10 X 1	12 mm	7/16 20UNF	12 mm	G1/4	12 mm
BOLTS - C	-	-	-	-	-	-	-	-	-	-	-	-	-	-	4-5/16 18UNC	13 mm	4-M8	13 mm



## MOTOR SHAFT EXTENSIONS

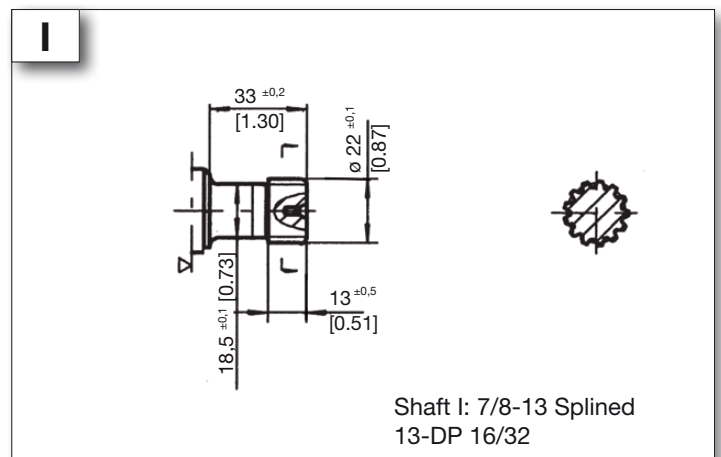
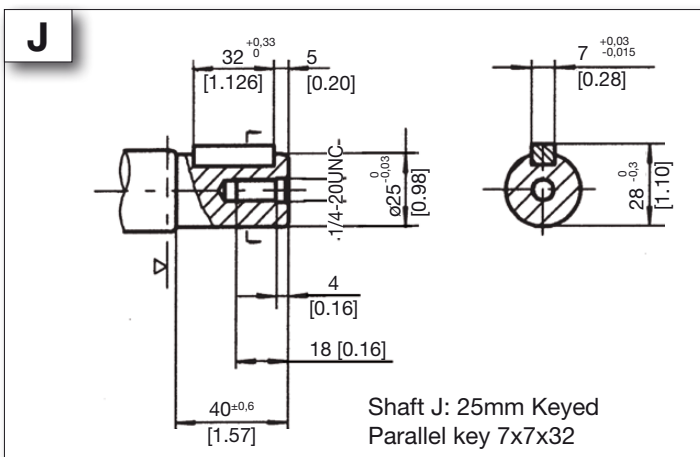
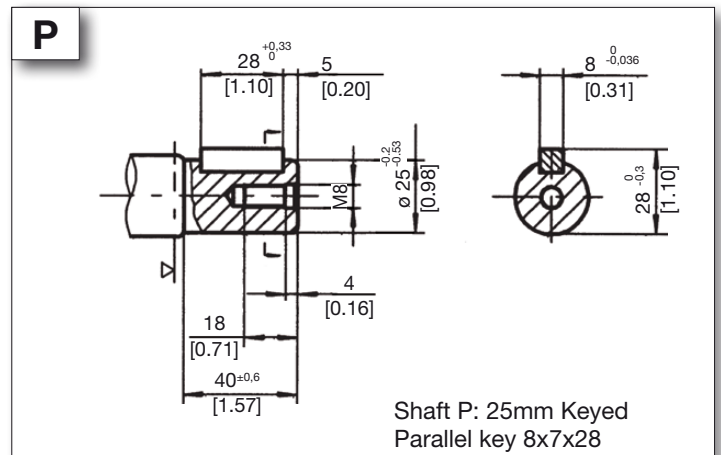
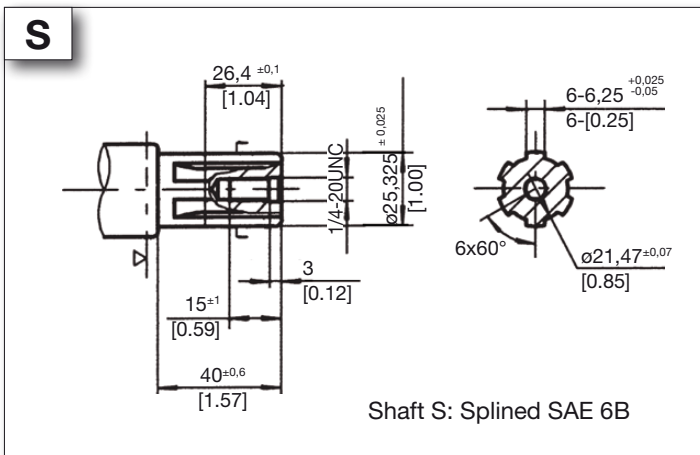
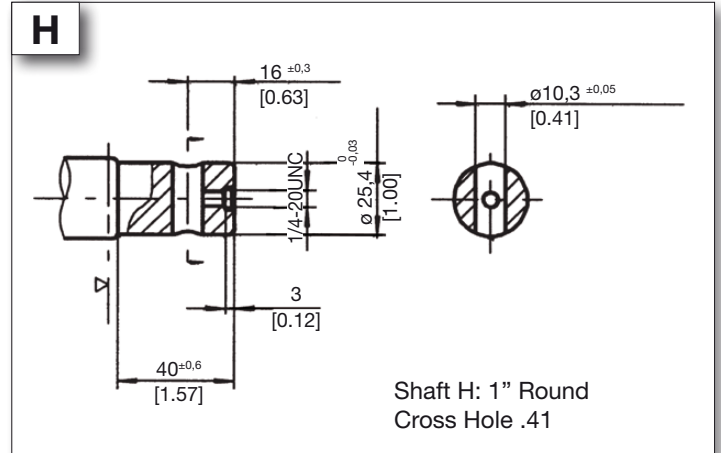
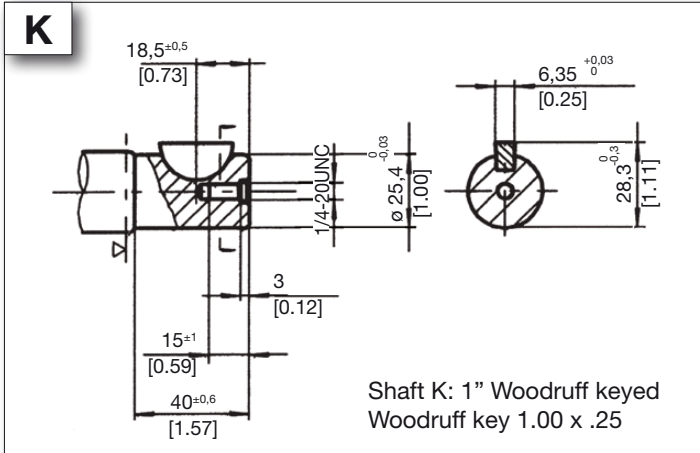

▷ Motor Mounting Surface

## MOTOR SHAFT EXTENSIONS

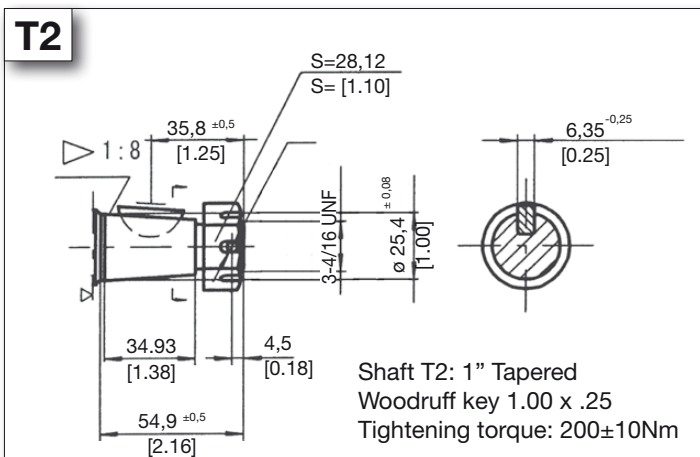
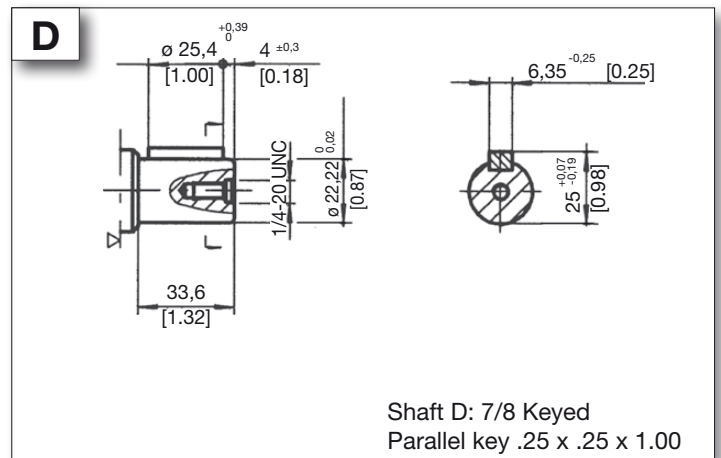
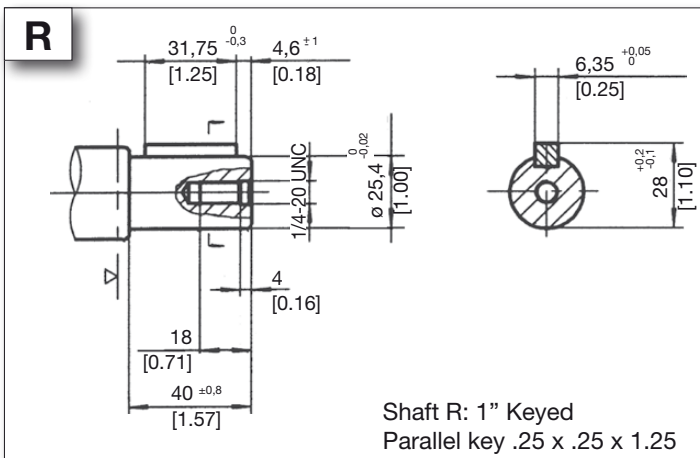
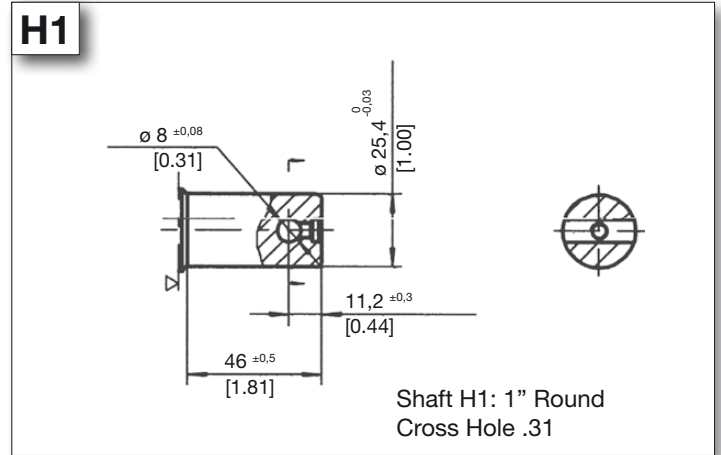
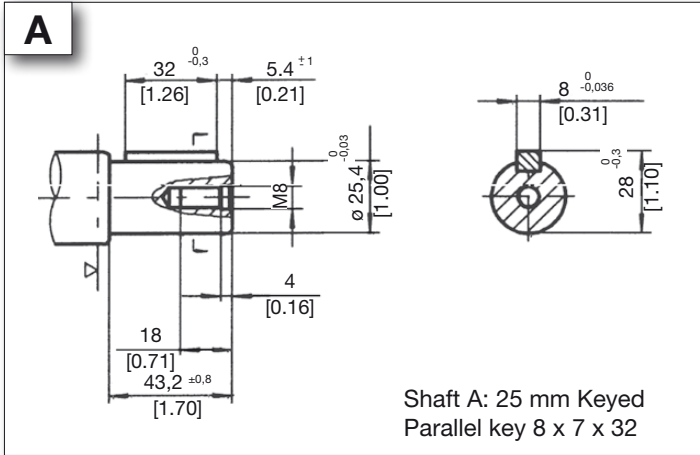

## ADDITIONAL INFORMATION

### PERMISSIBLE SHAFT SEAL PRESSURE

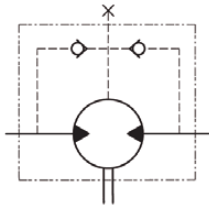

Note: Curve 1 for standard shaft seal  
Curve 2 for high pressure shaft seal

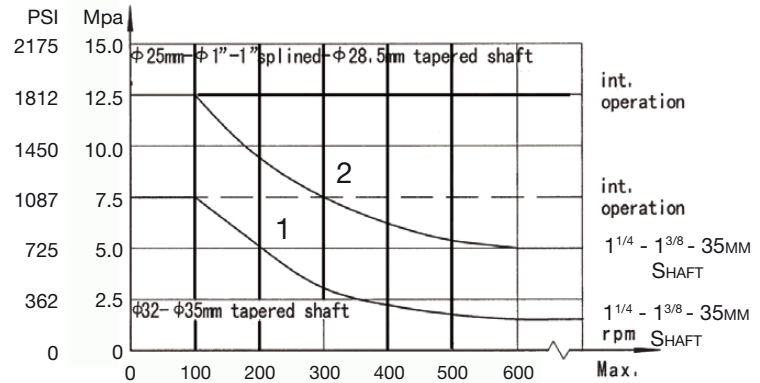

When viewing the motor from the output shaft end, port A is defined to be on the right and port B is defined to be on the left side. Standard rotation motors rotate CW when port A is pressurized. The motors are bi-directional and CCW rotation occurs when port B is pressurized.

Reverse rotation motors can special ordered which will operate with opposite rotation outlined above.

### SHAFT ROTATION DIRECTION

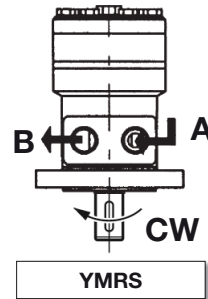

### STATUS OF THE SHAFT'S RADIAL FORCE

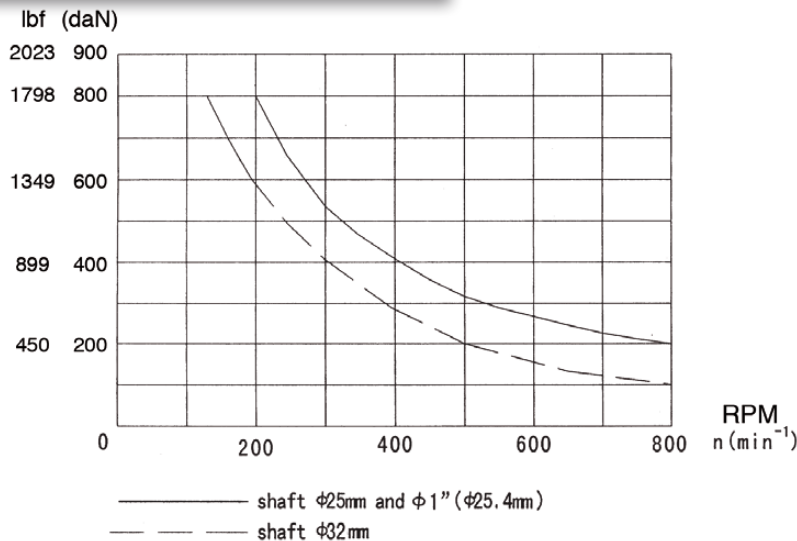

$$F_r = \frac{800 \cdot 25000}{n \cdot 95 + 1} \text{ daN}$$

$F_r$  = Radial Force (daN)  
 $L$  = Distance (mm)  
 $n$  = Speed (rpm)

Rhomb-flange  $L=30\text{mm}$   
 Square-flange  $L=24\text{mm}$

## ORDER INFORMATION

	1	2	3	4	5	6	7
YMRS							

1	2	3	4	5	6	7
DISP.	FLANGE	OUTPUT SHAFT	PORT AND DRAIN PORT	ROTATION DIRECTION	PAINT	SPECIAL OPTIONS
50	H2 SAE - A 2 Bolt Pilot .25"x0.31"	K Shaft K: 1" Woodruff keyed • Woodruff key 1.00 x .25	G G1/2, G1/4	NONE STANDARD	00 NO PAINT	NONE STANDARD
80	H6 4 Bolt Magneto Pilot .25"x0.31"	H Shaft H: 1" Round Cross Hole .41	S 7/8-14 O-ring 7/16-20 UNF	R OPPOSITE		N NEEDLE BEARING
100	H4 4 Bolt Flange Pilot .75"x0.11" 4 bolts: 3/8 - 16UNC	S Shaft S: Splined SAE 6B	P 1/2NPTF, 7/16-20 UNF		B BLACK	
125	H5 4 Bolt Flange Pilot Ø44.4x2.8 4 x M10	P Shaft P: 25mm Keyed Parallel key 8x7x28	R PT(Rc)1/2 , PT(Rc)1/4			
160		J Shaft J: 25mm Keyed Parallel key 7x7x32	M1 M18 X 1.5, M10 X 1			FR FREE RUNNING
200		I Shaft I: 7/8 -13 Splined 13-DP16/32	M2 M20 X 1.5, M10 X 1			
250		A Shaft A: 25mm Keyed Parallel key 8x7x32	M3 M22 X 1.5, M10 X 1			LSV LOW SPEED VALVE
315		H1 Shaft H1: 1" Round Cross Hole .31	B4 Ø10 O-ring manifold 4 x 5/16-18 7/16-20UNF			CRS CORROSION RESISTANT SHAFT
375		R Shaft R: 1" Keyed Parallel Key .25x.25x1.25	B5 Ø10 O-ring manifold 4 x M8, 7/16-20UNF			HPS HIGH PRESSURE SEAL
		D Shaft D: 7/8 Keyed Parallel key .25x.25x1.00				HTS HIGH TEMP SEAL
		T2 Shaft T2: 1" Tapered Woodruff key 1.00x.25 Tightening torque: 200±10Nm				

### ORDERING CODE:

All options have been determined with letters, numbers or combinations. All boxes must be filled with proper codes. If specification is not in the table, please contact us with your requirements.

# YMH



The **YMH** series motor uses the **spool valve** shaft distribution design for simplicity, efficiency and compactness. This design integrates the distribution and hydraulic bearing design with the motor shaft.

This series uses the more advanced **“ROLLER”** gear type. It is manufactured with the most advanced technology and equipment to improve efficiency, smoothness, lower leakage and better overall performance.

These motors are very compact, economical, and powerful without the need of a reducer to deliver high torque.

The large number of shaft, flange, port and special options make this a very flexible motor useful for many applications.

## SPECIFICATIONS

Distribution Type	Model	Displacement		Max. Operating Pressure		Speed Range Continuous	Max. Output Power	
		[in <sup>3</sup> ./rev]	[12.21~30.52]	[PSI]	[2900]		[HP]	[15]
Spool Valve Distribution	YMP	cm <sup>3</sup> /rev.	<b>200 ~ 500</b>	MPA	20	30~366	Kw	11

## QUICK REFERENCE GUIDE

### YMH SERIES QUICK REFERENCE:

Displacements				
[in <sup>3</sup> ./rev]	cm <sup>3</sup> /rev.			
[12.4]	203.2	FLOW UP TO	90 LPM	[23.78 GPM]
[15.61]	255.9	PRESSURE UP TO	20 MPa	[2900 PSI]
[19.29]	316.1	TORQUE UP TO	533 Nm	[4713lb.-in.]
[24.80]	406.0	POWER UP TO	17 Kw	[21.6 HP]
[29.85]	489.2	SPEED UP TO	439 RPM	

**Shaft Seals:** Standard high pressure shaft seals permit applications in series or without drain line when required

**Low Speed Valving:** These motors are manufactured following strict procedures to reduce tolerances between all components to permit lower speed, higher efficiency and smoother rotation at very low speeds. These motors are not for high speed or low pressure applications.

**Free Running:** Motors with this option have increased clearances in the rotor set. This allows improved mechanical efficiency, longer life and better performance for high-speed / high-flow applications, winch or similar applications where the motor is cross-ported to allow manual free turning also remay benefit from this option to allow smoother easier free turning of the motor. Last, applications which have many reversals or high pressure spikes can also benefit since the pressure spikes will be reduced by relieving (cross-porting) such spikes internally in the motor. The trade off of these benefits is a slight reduction in volumetric efficiency, particularly at high pressure conditions.

**Special Motors:** These motors have special options like nickel plated shafts or housings for applications in corrosive environments.

### APPLICATION GUIDELINES:

For optimum results the following working conditions are recommended:

- \* Oil temperature should be between 20° - 60° C [68° - 180° F]
- \* Oil filter of 10 - 20 micron
- \* Oil viscosity 42 - 74 mm<sup>2</sup>/s CSA at 40° C
- \* Different shafts are used when there is a radial load or not. Check data pages
- \* For longer life we suggest the motor at start up, run for a shorter period of time (one hour) at no more than 30% of rated speed and pressure.

## SPECIFICATION DATA

DISTRIBUTION TYPE		YMH 200	YMH 250	YMH 315	YMH 400	YMH 500	
GEOMETRIC DISPLACEMENT	[in <sup>3</sup> /rev.]	[12.40]	[15.62]	[19.29]	[24.80]	[29.86]	
	cm <sup>3</sup> /rev.	<b>203.2</b>	<b>255.9</b>	<b>316.1</b>	<b>406.4</b>	<b>489.2</b>	
MAX. SPEED RPM	CONT.	366	290	236	183	155	
	<b>INT.</b>	<b>439</b>	<b>348</b>	<b>282</b>	<b>220</b>	<b>166</b>	
MAX. TORQUE [LB. IN.] N*M	CONT.	[LB. IN.]	[4510]	[5492]	[6545]	[7641]	[7066]
		<b>N*M</b>	<b>510</b>	<b>621</b>	<b>740</b>	<b>864</b>	<b>799</b>
	INT.	[LB. IN.]	[5121]	[6208]	[7314]	[8738]	[8588]
		<b>N*M</b>	<b>579</b>	<b>702</b>	<b>827</b>	<b>988</b>	<b>971</b>
	PEAK	[LB. IN.]	[5757]	[6987]	[8225]	[9658]	[9658]
		<b>N*M</b>	<b>651</b>	<b>790</b>	<b>930</b>	<b>1092</b>	<b>1092</b>
MAX. OUTPUT [HP] KW	CONT.	[HP]	[15]	[12]	[13]	[10]	[9]
		<b>KW</b>	<b>11.2</b>	<b>9.2</b>	<b>9.8</b>	<b>7.4</b>	<b>6.5</b>
	INT.	[HP]	[23]	[20]	[17]	[17]	[15]
		<b>KW</b>	<b>17</b>	<b>15</b>	<b>13</b>	<b>13</b>	<b>11</b>
MAX. PRESSURE DROP [PSI] MPa	CONT.	[PSI]	[2538]	[2538]	[2538]	[2248]	[1813]
		<b>MPa</b>	<b>17.5</b>	<b>17.5</b>	<b>17.5</b>	<b>15.5</b>	<b>12.5</b>
	INT.	[PSI]	[2900]	[2900]	[2900]	[2755]	[2320]
		<b>MPa</b>	<b>20</b>	<b>20</b>	<b>20</b>	<b>19</b>	<b>16</b>
	PEAK	[PSI]	[3263]	[3263]	[3263]	[3045]	[2610]
		<b>MPa</b>	<b>22.5</b>	<b>22.5</b>	<b>22.5</b>	<b>21</b>	<b>18</b>
MAX. FLOW [GPM] L/MIN	CONT.	[GPM]	[19.8]	[19.8]	[19.8]	[19.8]	[19.8]
		<b>L/MIN</b>	<b>75</b>	<b>75</b>	<b>75</b>	<b>75</b>	<b>75</b>
	INT.	[GPM]	[23.7]	[23.7]	[23.7]	[23.7]	[23.7]
		<b>L/MIN</b>	<b>90</b>	<b>90</b>	<b>90</b>	<b>90</b>	<b>90</b>
WEIGHT [LB] KG	[LB]	[23]	[24]	[25]	[27]	[29]	
	KG	10.5	11	11.5	12.3	13	

\* Continuous pressure:

\* Intermittent pressure:

\* Peak pressure:

Max. value of operating motor continuously.

Max. value of operating motor in 6 seconds per minute.

Max. value of operating motor in 0.6 second per minute.

## PERFORMANCE DATA

YMH 200 [12.40 in<sup>3</sup>/rev] 203.2 cm<sup>3</sup>/rev. Max cont. Max int.

	[507] 3.5	[1015] 7	[1522] 10.5	[2030] 14	[2537] 17.5	[2900] 20	[PSI] MPa
GPM L/min	[1.3] 5	[867] 98 <b>25</b>	[1716] 194 <b>25</b>	[2512] 284 <b>22</b>			
	[2.6] 10	[893] 101 <b>43</b>	[1804] 204 <b>41</b>	[2662] 301 <b>36</b>	[3458] 391 <b>29</b>	[4263] 482 <b>14</b>	
Flow (L/min)	[5.3] 20	[876] 99 <b>100</b>	[1778] 201 <b>97</b>	[2689] 304 <b>93</b>	[3555] 402 <b>85</b>	[4502] 509 <b>69</b>	[5094] 576 <b>56</b>
	[7.9] 30	[858] 97 <b>145</b>	[1742] 197 <b>143</b>	[2653] 300 <b>139</b>	[3555] 402 <b>130</b>	[4510] 510 <b>114</b>	[5121] 579 <b>101</b>
	[10.6] 40	[796] 90 <b>200</b>	[1680] 190 <b>200</b>	[2582] 292 <b>200</b>	[3529] 399 <b>188</b>	[4484] 507 <b>168</b>	[5112] 578 <b>153</b>
	[13.2] 50	[725] 82 <b>248</b>	[1618] 183 <b>246</b>	[2512] 284 <b>244</b>	[3467] 392 <b>235</b>	[4422] 500 <b>213</b>	[5050] 571 <b>199</b>
	[15.9] 60	[646] 73 <b>292</b>	[1539] 174 <b>290</b>	[2423] 274 <b>287</b>	[3396] 384 <b>279</b>	[4360] 493 <b>260</b>	[4979] 563 <b>244</b>
	[18.5] 70	[557] 63 <b>352</b>	[1442] 163 <b>350</b>	[2335] 264 <b>349</b>	[3308] 374 <b>338</b>	[4254] 481 <b>318</b>	[4900] 554 <b>301</b>
	[19.8] 75	[522] 59 <b>366</b>	[1389] 157 <b>365</b>	[2291] 259 <b>363</b>	[3237] 366 <b>355</b>	[4201] 475 <b>335</b>	[4838] 547 <b>319</b>
	[21.1] 80	[469] 53 <b>381</b>	[1327] 150 <b>381</b>	[2238] 253 <b>380</b>	[3166] 358 <b>371</b>	[4121] 466 <b>352</b>	[4758] 538 <b>338</b>
	[23.8] 90	[345] 39 <b>443</b>	[1238] 140 <b>437</b>	[2131] 241 <b>434</b>	[3078] 348 <b>426</b>	[4033] 456 <b>407</b>	[4652] 526 <b>392</b>
	Max cont.						
Max int.							Max int.

TORQUE (LB-IN)  
TORQUE (N•M)  
SPEED (RPM)

YMH 250 [15.61 in<sup>3</sup>/rev] 255.9 cm<sup>3</sup>/rev. Max cont. Max int.

	[507] 3.5	[1015] 7	[1305] 9	[1740] 12	[2102] 14.5	[2537] 17.5	[2900] 20	[PSI] MPa
GPM L/min	[1.3] 5	[1070] 121 <b>19</b>	[2176] 246 <b>19</b>	[2812] 318 <b>18</b>	[3520] 398 <b>14</b>			
	[2.6] 10	[1150] 130 <b>34</b>	[2282] 258 <b>33</b>	[2927] 331 <b>31</b>	[3759] 425 <b>29</b>	[4555] 515 <b>23</b>	[5262] 595 <b>12</b>	
Flow (L/min)	[5.3] 20	[1150] 130 <b>78</b>	[2282] 258 <b>77</b>	[2936] 332 <b>76</b>	[3821] 432 <b>73</b>	[4599] 520 <b>65</b>	[5492] 621 <b>53</b>	[6208] 702 <b>42</b>
	[7.9] 30	[1079] 122 <b>115</b>	[2220] 251 <b>113</b>	[2892] 327 <b>111</b>	[3794] 429 <b>105</b>	[4599] 520 <b>96</b>	[5492] 621 <b>84</b>	[6191] 700 <b>75</b>
	[10.6] 40	[1017] 115 <b>157</b>	[2123] 240 <b>157</b>	[2857] 323 <b>156</b>	[3732] 422 <b>150</b>	[4537] 513 <b>139</b>	[5448] 616 <b>127</b>	[6173] 698 <b>114</b>
	[13.2] 50	[929] 105 <b>196</b>	[2052] 232 <b>195</b>	[2777] 314 <b>192</b>	[3635] 411 <b>185</b>	[4466] 505 <b>173</b>	[5359] 606 <b>159</b>	[6076] 687 <b>147</b>
	[15.9] 60	[831] 94 <b>232</b>	[1946] 220 <b>230</b>	[2671] 302 <b>226</b>	[3546] 401 <b>218</b>	[4387] 496 <b>206</b>	[5271] 596 <b>192</b>	[5979] 676 <b>180</b>
	[18.5] 70	[720] 81.4 <b>274</b>	[1848] 209 <b>274</b>	[2547] 288 <b>274</b>	[3440] 389 <b>266</b>	[4281] 484 <b>252</b>	[5147] 582 <b>238</b>	[5890] 666 <b>222</b>
	[19.8] 75	[637] 72 <b>290</b>	[1795] 203 <b>289</b>	[2476] 280 <b>287</b>	[3370] 381 <b>279</b>	[4201] 475 <b>266</b>	[5076] 574 <b>251</b>	[5828] 659 <b>236</b>
	[21.1] 80	[584] 66 <b>303</b>	[1716] 194 <b>302</b>	[2414] 273 <b>298</b>	[3281] 371 <b>290</b>	[4130] 467 <b>279</b>	[5006] 566 <b>264</b>	[5757] 651 <b>249</b>
	[23.8] 90	[433] 49 <b>348</b>	[1574] 178 <b>347</b>	[2264] 256 <b>345</b>	[3140] 355 <b>337</b>	[4006] 453 <b>325</b>	[4882] 552 <b>309</b>	[5607] 634 <b>292</b>
	Max cont.							
Max int.								Max int.

TORQUE (LB-IN)  
TORQUE (N•M)  
SPEED (RPM)

YMH 315 [19.29 in<sup>3</sup>/rev] 316.1 cm<sup>3</sup>/rev. Max cont. Max int.

	[507] 3.5	[1087] 7.5	[1450] 10	[1957] 13.5	[2247] 15.5	[2537] 17.5	[2900] 20	[PSI] MPa
GPM L/min	[1.3] 5	[1371] 155 <b>16</b>	[2874] 325 <b>13</b>					
	[2.6] 10	[1442] 163 <b>27</b>	[3025] 342 <b>24</b>	[4015] 454 <b>18</b>	[4917] 556 <b>14</b>			
Flow (L/min)	[5.3] 20	[1495] 169 <b>63</b>	[3087] 349 <b>61</b>	[4048] 469 <b>55</b>	[5147] 582 <b>48</b>	[5872] 664 <b>40</b>	[6483] 733 <b>32</b>	[7155] 809 <b>19</b>
	[7.9] 30	[1459] 165 <b>93</b>	[3042] 344 <b>89</b>	[4157] 470 <b>82</b>	[5130] 580 <b>77</b>	[5917] 669 <b>67</b>	[6545] 740 <b>59</b>	[7287] 824 <b>46</b>
	[10.6] 40	[1362] 154 <b>126</b>	[2980] 337 <b>126</b>	[4112] 465 <b>119</b>	[5103] 577 <b>111</b>	[5864] 663 <b>99</b>	[6518] 737 <b>88</b>	[7314] 827 <b>73</b>
	[13.2] 50	[1247] 141 <b>159</b>	[2874] 325 <b>155</b>	[4024] 455 <b>148</b>	[5023] 568 <b>139</b>	[5802] 656 <b>126</b>	[6438] 728 <b>115</b>	[7287] 824 <b>98</b>
	[15.9] 60	[1070] 121 <b>187</b>	[2759] 312 <b>186</b>	[3891] 440 <b>179</b>	[4908] 555 <b>169</b>	[5687] 643 <b>154</b>	[6323] 715 <b>143</b>	[7181] 812 <b>124</b>
	[18.5] 70	[911] 103 <b>222</b>	[2636] 298 <b>222</b>	[3759] 425 <b>215</b>	[4785] 541 <b>205</b>	[5581] 631 <b>187</b>	[6217] 703 <b>176</b>	[7075] 800 <b>157</b>
	[19.8] 75	[831] 94 <b>236</b>	[2538] 287 <b>233</b>	[3688] 417 <b>224</b>	[4678] 529 <b>215</b>	[5510] 623 <b>196</b>	[6155] 696 <b>184</b>	[7004] 792 <b>166</b>
	[21.1] 80	[725] 82 <b>246</b>	[2450] 277 <b>244</b>	[3591] 406 <b>236</b>	[4581] 518 <b>228</b>	[5404] 611 <b>210</b>	[6085] 688 <b>197</b>	[6934] 784 <b>174</b>
	[23.8] 90	[548] 62 <b>282</b>	[2264] 256 <b>280</b>	[3414] 386 <b>275</b>	[4387] 496 <b>266</b>	[5245] 593 <b>248</b>	[5917] 669 <b>234</b>	[6783] 767 <b>209</b>
	Max cont.							
Max int.								Max int.

TORQUE (LB-IN)  
TORQUE (N•M)  
SPEED (RPM)

YMH 400 [24.80 in<sup>3</sup>/rev] 406.40 cm<sup>3</sup>/rev. Max cont. Max int.

	[507] 3.5	[870] 6	[1522] 10.5	[1812] 12.5	[2247] 15.5	[2755] 19	[PSI] MPa
GPM L/min	[1.3] 5	[1733] 196 <b>13</b>	[3078] 348 <b>13</b>	[4564] 516 <b>10</b>			
	[2.6] 10	[1813] 205 <b>22</b>	[3210] 363 <b>21</b>	[4829] 546 <b>21</b>	[6209] 702 <b>17</b>	[7597] 859 <b>11</b>	
Flow (L/min)	[5.3] 20	[1848] 209 <b>50</b>	[3237] 366 <b>49</b>	[4802] 543 <b>46</b>	[6262] 708 <b>41</b>	[7730] 874 <b>36</b>	[8738] 988 <b>31</b>
	[7.9] 30	[1778] 201 <b>73</b>	[3157] 357 <b>72</b>	[4793] 542 <b>70</b>	[6244] 706 <b>63</b>	[7641] 864 <b>56</b>	[8703] 984 <b>51</b>
	[10.6] 40	[1725] 195 <b>99</b>	[3060] 346 <b>98</b>	[4705] 532 <b>96</b>	[6200] 701 <b>86</b>	[7588] 858 <b>77</b>	[8605] 973 <b>71</b>
	[13.2] 50	[1530] 173 <b>123</b>	[2936] 332 <b>122</b>	[4581] 518 <b>118</b>	[6076] 687 <b>107</b>	[7500] 848 <b>97</b>	[8473] 958 <b>90</b>
	[15.9] 60	[1362] 154 <b>146</b>	[2821] 319 <b>144</b>	[4431] 501 <b>141</b>	[5908] 668 <b>128</b>	[7368] 833 <b>115</b>	[8349] 944 <b>106</b>
	[18.5] 70	[1221] 138 <b>174</b>	[2697] 305 <b>173</b>	[4245] 480 <b>169</b>	[5740] 649 <b>156</b>	[7199] 814 <b>141</b>	[8181] 925 <b>130</b>
	[19.8] 75	[1132] 128 <b>183</b>	[2600] 294 <b>181</b>	[4121] 466 <b>177</b>	[5634] 637 <b>163</b>	[7093] 802 <b>149</b>	[8057] 911 <b>138</b>
	[21.1] 80	[999] 113 <b>192</b>	[2450] 277 <b>191</b>	[3989] 451 <b>188</b>	[5492] 621 <b>174</b>	[6951] 786 <b>158</b>	[7951] 899 <b>144</b>
	[23.8] 90	[796] 90 <b>220</b>	[2264] 256 <b>220</b>	[3829] 433 <b>215</b>	[5262] 595 <b>202</b>	[6783] 767 <b>183</b>	[7792] 881 <b>165</b>
	Max cont.						
Max int.							Max int.

TORQUE (LB-IN)  
TORQUE (N•M)  
SPEED (RPM)



## PERFORMANCE DATA

YMH 500 [29.85 in<sup>3</sup>/rev] 489.2 cm<sup>3</sup>/rev. Max cont. Max int.

		362 2.5	725 5	1232 8.5	1450 10	1812 12.5	2320 16	[PSI] MPa
GPM L/ min	[1.3] 5	[1459] 165 <b>11</b>	[2804] 317 <b>11</b>	[4564] 516 <b>8</b>				
	[2.6] 10	[1574] 178 <b>20</b>	[2963] 335 <b>19</b>	[4908] 555 <b>17</b>	[5917] 669 <b>15</b>	[6996] 791 <b>13</b>	[8570] 969 <b>9</b>	
Flow (L/min)	[5.3] 20	[1565] 177 <b>42</b>	[2927] 331 <b>42</b>	[4944] 559 <b>41</b>	[5952] 673 <b>38</b>	[7066] 799 <b>36</b>	[8738] 988 <b>29</b>	TORQUE (LB-IN) TORQUE (N•M) SPEED (RPM)
	[7.9] 30	[1521] 172 <b>64</b>	[2830] 320 <b>63</b>	[4891] 553 <b>61</b>	[5864] 663 <b>57</b>	[7004] 792 <b>53</b>	[8694] 983 <b>47</b>	
	[10.6] 40	[1442] 163 <b>85</b>	[2733] 309 <b>85</b>	[4785] 541 <b>83</b>	[5784] 654 <b>79</b>	[6925] 783 <b>75</b>	[8588] 971 <b>67</b>	
	[13.2] 50	[1291] 146 <b>103</b>	[2618] 296 <b>103</b>	[4625] 523 <b>103</b>	[5616] 635 <b>97</b>	[6792] 768 <b>93</b>	[8437] 954 <b>85</b>	
	[15.9] 60	[1070] 121 <b>124</b>	[2432] 275 <b>124</b>	[4440] 502 <b>123</b>	[5430] 614 <b>117</b>	[6606] 747 <b>113</b>	[8260] 934 <b>103</b>	
	[18.5] 70	[858] 97 <b>148</b>	[2264] 256 <b>148</b>	[4263] 482 <b>148</b>	[5280] 597 <b>140</b>	[6447] 729 <b>134</b>	[8110] 917 <b>122</b>	
	[19.8] 75	[699] 79 <b>155</b>	[2123] 240 <b>155</b>	[4148] 469 <b>155</b>	[5147] 582 <b>152</b>	[6315] 714 <b>144</b>	[7977] 902 <b>130</b>	
	[21.1] 80	[531] 60 <b>166</b>	[1999] 226 <b>166</b>	[4006] 453 <b>166</b>	[5041] 570 <b>159</b>	[6200] 701 <b>153</b>	[7818] 884 <b>139</b>	Max cont.
	[23.8] 90	[301] 34 <b>166</b>	[1778] 201 <b>165</b>	[3723] 421 <b>164</b>	[4864] 550 <b>157</b>	[5952] 673 <b>156</b>	[7685] 869 <b>155</b>	Max int.



## MOTOR SHAFT EXTENSIONS

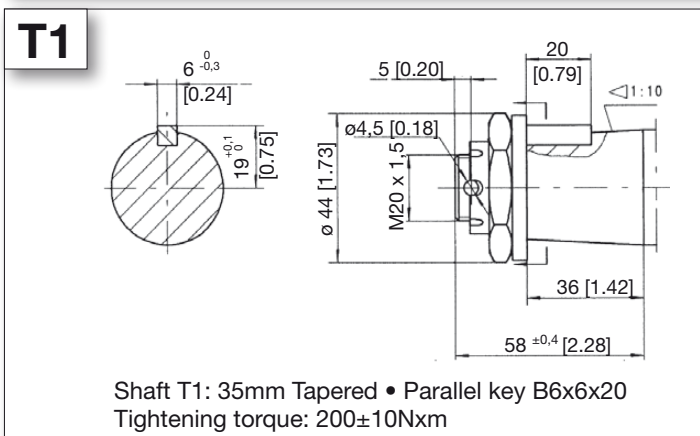
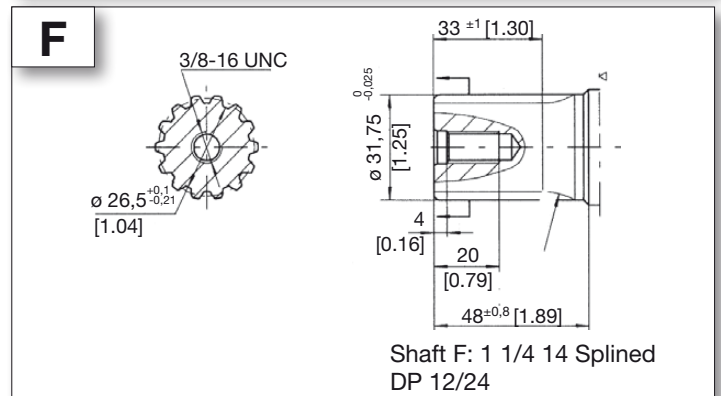
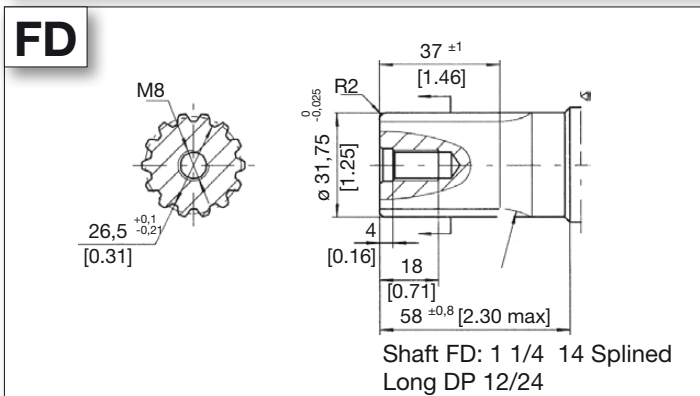
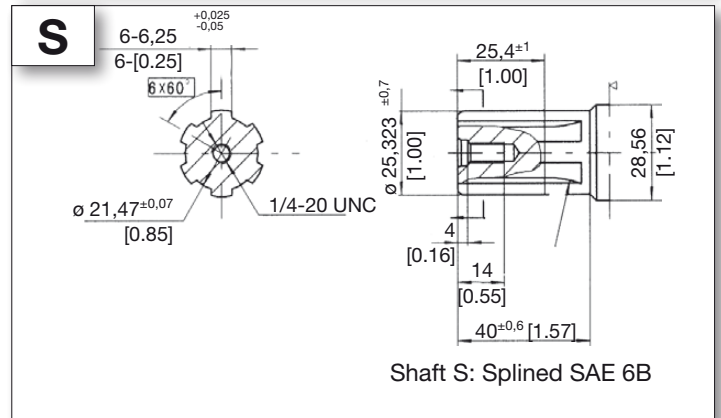
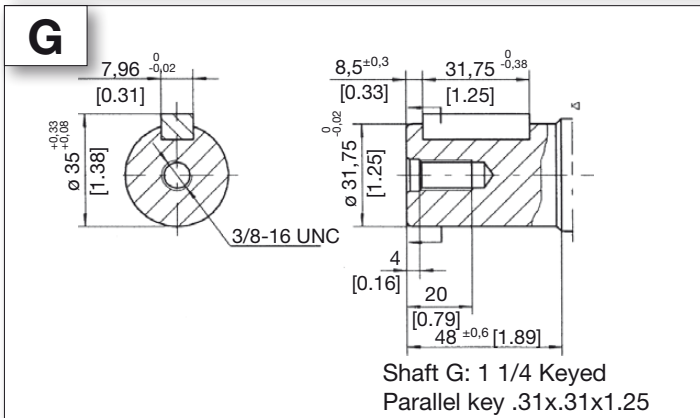
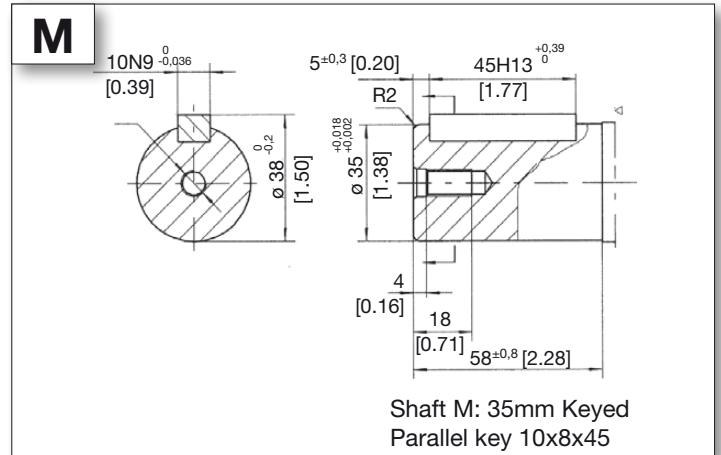
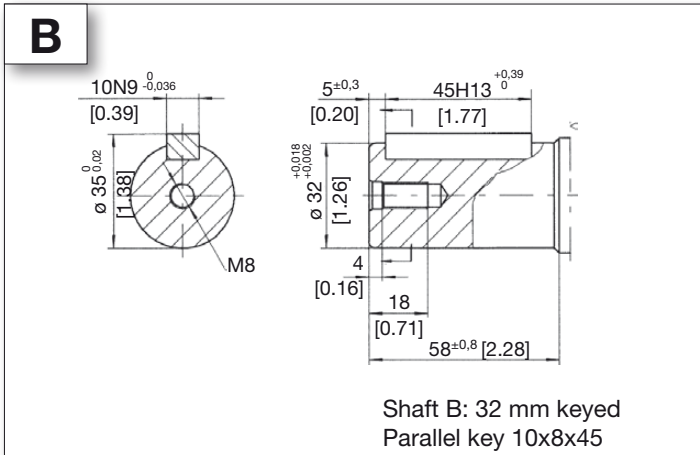

## ADDITIONAL INFORMATION

### PERMISSIBLE SHAFT SEAL PRESSURE

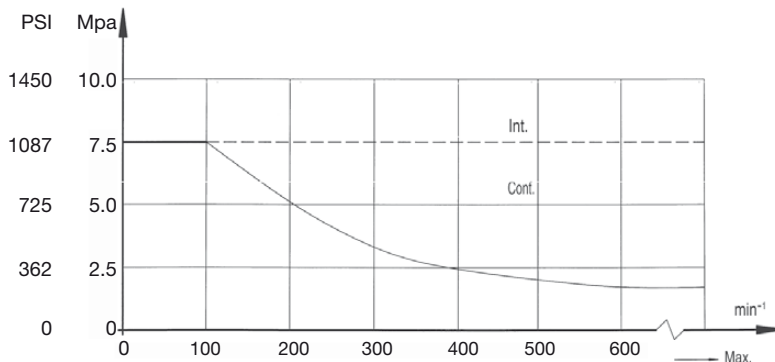
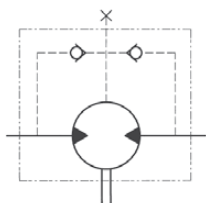

When viewing the motor from the output shaft end, port A is defined to be on the right and port B is defined to be on the left side. Standard rotation motors rotate CW when port A is pressurized. The motors are bi-directional and CCW rotation occurs when port B is pressurized.

Reverse rotation motors can special ordered which will operate with opposite rotation outlined above.

### PERMISSIBLE SHAFT SIDE LOAD

The permissible shaft load ( $P_{rad}$ ) is calculated from the speed ( $n$ ) and the distance ( $l$ ) between the point of load application and the mounting flange.

$$P_{rad} = \frac{1100}{n} \cdot \frac{250000}{103.5 + l} \text{ N}^*; l \text{ in mm}$$

$$P_{rad} = \frac{1100}{n} \cdot \frac{2215}{4.07 + l} \text{ lbf}^*; l \text{ in inch}$$

\* $n \geq 200 \text{ min}^{-1} \text{ (rpm)}$ ;  $l \leq 60 \text{ mm [2.36 in]}$   
 $n < 200 \text{ min}^{-1} \text{ (rpm)}$ ;  $\Rightarrow P_{Rmax} = 11000 \text{ N [2475 lbf]}$

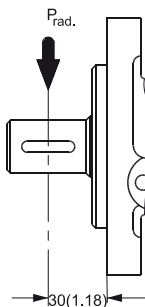
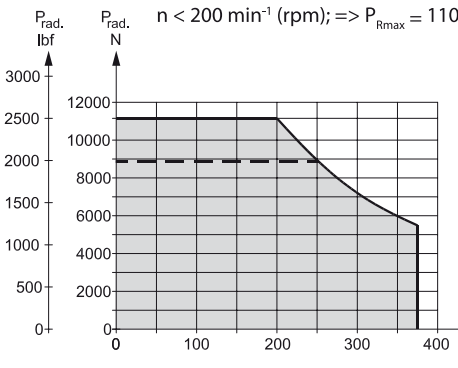

### SHAFT ROTATION DIRECTION

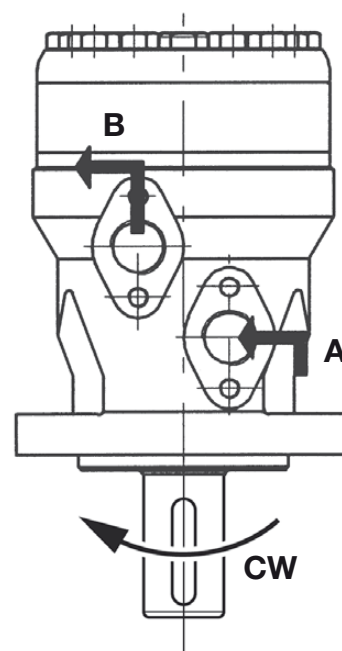

The drawing shows the permissible radial load when  $l = 30 \text{ mm [1.18 in]}$ .

## ORDERING INFORMATION

	1	2	3	4	5	6	7	8
YMH								

1	2		3		4		5		6		7			
DISP.	FLANGE		OUTPUT SHAFT		PORT AND DRAIN PORT		ROTATION DIRECTION		PAINT		SPECIAL OPTIONS			
200	4	MAGNETO 3.25 PILOT	<b>B</b>	Shaft: 32mm Keyed parallel key 10x8x45	<b>D</b>	G1/2 Manifold mount 4 X M8 G1/4	<b>NONE</b>	STANDARD	<b>OO</b>	NO PAINT	<b>NONE</b>	STANDARD		
250			<b>M</b>	Shaft: 35 Keyed parallel key 10x8x45	<b>S</b>	7/8-14 O-ring Manifold mount 4 X M8 7/16-20 UNF	<b>R</b>	OPPOSITE			<b>O</b>	NO CASE DRAIN		
315			<b>F</b>	Shaft: 11/4 14 splined 14-DP12/24	<b>M</b>	M22 X 1.5 Manifold mount 4 x M8, M14 x 1.5				<b>B</b>	BLACK	<b>FR</b>	FREE RUN- NING	
400			<b>FD</b>	Long Shaft: 11/4 14spli- ned 14-DP12/24	<b>P</b>	1/2-14 NPTF Manifold 4xM8, 7/16-20UNF								
500			<b>G</b>	Shaft: 11/4 Keyed parallel key .31x.31x11/4	<b>R</b>	PT(Rc)1/2 Manifold mount 4 x M8 ,PT(Rc)1/4							<b>CRS</b>	CORROSION RESISTANT SHAFT
			<b>T1</b>	35mm tapered parallel key B6x6x20									<b>HPS</b>	HIGH PRESSURE SEAL
			<b>S</b>	Shaft: Splined SAE 6B							<b>HTS</b>	HIGH TEMP SEAL		

### ORDERING CODE:

All options have been determined with letters, numbers or combinations. All boxes must be filled with proper codes. If specification is not in the table, please contact us with your requirements.



# YMSY



The **YMSY** series motors adapts an advanced **ROLLER** gear set designed with disc distribution flow and high pressure.

This motor series uses the “**ROTOR**” gear type manufactured with most advanced technology and quality available to provide low pressure start up, smooth reliable operation and high efficiency.

The output shaft tapered roller bearings allow for high axial and radial forces.

Advanced design in disc distribution flow, which can automatically compensate in operating with high volume efficiency and long life.

The YMSY series has the same dimensions and mounting data as the YMS series. This series is rated **10-20%** higher for higher torque and higher pressure applications.

## SPECIFICATIONS

Distribution Type	Model	Displacement		Max. Operating Pressure		Speed Range Continuous	Max. Output Power	
		[in <sup>3</sup> ./rev]	[4.88 ~ 22.88]	[PSI]	[3263]		RPM	[HP]
Disc Distribution	YMSY	cm <sup>3</sup> /rev.	80 ~ 475	MPA	24.5	30 ~ 800	Kw	18

## QUICK REFERENCE GUIDE

### YMSY SERIES QUICK REFERENCE:

Displacements				
[in <sup>3</sup> ./rev]	cm <sup>3</sup> /rev.			
[4.92]	80.6			
[6.15]	100.8			
[7.63]	125			
[9.40]	154	FLOW UP TO	90 LPM	[23.78 GPM]
[11.84]	194	PRESSURE UP TO	22.5 MPA	[3262 PSI]
[14.83]	243	TORQUE UP TO	1100 NM	[9728 LB. IN.]
[18.97]	311	SPEED UP TO	470 RPM	
[24.4]	394			
[28.98]	475			

**Shaft Seals:** Standard high pressure shaft seals permit applications in series or without drain line when required

**Low Speed Valving:** These motors are manufactured following strict procedures to reduce tolerances between all components to permit lower speed, higher efficiency and smoother rotation at very low speeds. These motors are not for high speed or low pressure applications.

**Free Running:** Motors with this option have increased clearances in the rotor set. This allows improved mechanical efficiency, longer life and better performance for high-speed / high-flow applications, winch or similar applications where the motor is cross-ported to allow manual free turning also remay benefit from this option to allow smoother easier free turning of the motor. Last, applications which have many reversals or high pressure spikes can also benefit since the pressure spikes will be reduced by relieving (cross-porting) such spikes internally in the motor. The trade off of these benefits is a slight reduction in volumetric efficiency, particularly at high pressure conditions.

**Special Motors:** These motors have special options like nickel plated shafts or housings for applications in corrosive environments.

### APPLICATION GUIDELINES:

For optimum results the following working conditions are recommended:

- \* Oil temperature should be between 20° - 60° C [68° - 180° F]
- \* Oil filter of 10 - 20 micron
- \* Oil viscosity 42 - 74 mm<sup>2</sup>/s CSA at 40° C
- \* Different shafts are used when there is a radial load or not. Check data pages
- \* For longer life we suggest the motor at start up, run for a shorter period of time (one hour) at no more than 30% of rated speed and pressure.



## SPECIFICATION DATA

DISTRIBUTION TYPE		YMSY 80	YMSY 100	YMSY 125	YMSY 160	YMSY 200	YMSY 250	YMSY 315	YMSY 400	YMSY 475	
GEOMETRIC DISPLACEMENT	[in <sup>3</sup> ./rev.]	[4.92]	[6.15]	[7.63]	[9.40]	[11.84]	[14.83]	[18.97]	[24.04]	[28.98]	
	cm <sup>3</sup> /rev.	80.6	100.8	125	154	194	243	311	394	475	
MAX. SPEED RPM	CONT.	800	748	600	470	375	300	240	185	155	
	INT.	988	900	720	560	450	360	280	225	185	
MAX. TORQUE [LB. IN.] N*M	CONT.	[LB. IN.]	[1990]	[2565]	[3228]	[4289]	[5183]	[6262]	[7783]	[7783]	[8048]
		<b>N*M</b>	<b>225</b>	<b>290</b>	<b>365</b>	<b>485</b>	<b>586</b>	<b>708</b>	<b>880</b>	<b>880</b>	<b>910</b>
	INT.	[LB. IN.]	[2211]	[2830]	[3538]	[4776]	[5704]	[7128]	[8490]	[8490]	[8490]
		<b>N*M</b>	<b>250</b>	<b>320</b>	<b>400</b>	<b>540</b>	<b>645</b>	<b>806</b>	<b>960</b>	<b>960</b>	<b>960</b>
MAX. OUTPUT [HP] KW	CONT.	[HP]	[21]	[24]	[24]	[24]	[24]	[23]	[15]	[12]	
		<b>KW</b>	<b>16</b>	<b>18</b>	<b>18</b>	<b>18.1</b>	<b>18.1</b>	<b>18</b>	<b>17</b>	<b>11</b>	<b>9</b>
	INT.	[HP]	[27]	[29]	[31]	[34]	[32]	[32]	[27]	[16]	[15]
		<b>KW</b>	<b>20</b>	<b>22</b>	<b>23</b>	<b>25</b>	<b>24</b>	<b>23.8</b>	<b>20.2</b>	<b>12</b>	<b>11</b>
MAX. PRES-SURE DROP [PSI] MP <sub>A</sub>	CONT.	[PSI]	[2913]	[2913]	[2913]	[3045]	[3045]	[2900]	[2900]	[2320]	[2030]
		<b>MP<sub>A</sub></b>	<b>20.5</b>	<b>20.5</b>	<b>20.5</b>	<b>21</b>	<b>21</b>	<b>20</b>	<b>20</b>	<b>16</b>	<b>14</b>
	INT.	[PSI]	[3263]	[3263]	[3263]	[3263]	[3263]	[3263]	[3263]	[2538]	[2175]
		<b>MP<sub>A</sub></b>	<b>22.5</b>	<b>22.5</b>	<b>22.5</b>	<b>22.5</b>	<b>22.5</b>	<b>22.5</b>	<b>22.5</b>	<b>17.5</b>	<b>15</b>
	PEAK	[PSI]	[4278]	[4278]	[4278]	[3263]	[3263]	[3263]	[3263]	[2900]	[2538]
		<b>MP<sub>A</sub></b>	<b>29.5</b>	<b>29.5</b>	<b>29.5</b>	<b>22.5</b>	<b>22.5</b>	<b>22.5</b>	<b>22.5</b>	<b>20</b>	<b>17.5</b>
MAX. FLOW [GPM] L/MIN	CONT.	[GPM]	[17.17]	[19.8]	[19.8]	[19.8]	[19.8]	[19.8]	[19.8]	[19.8]	
		<b>L/MIN</b>	<b>65</b>	<b>75</b>	<b>75</b>	<b>75</b>	<b>75</b>	<b>75</b>	<b>75</b>	<b>75</b>	<b>75</b>
	INT.	[GPM]	[21.14]	[23.7]	[23.7]	[23.7]	[23.7]	[23.7]	[23.7]	[23.7]	[23.7]
		<b>L/MIN</b>	<b>80</b>	<b>90</b>	<b>90</b>	<b>90</b>	<b>90</b>	<b>90</b>	<b>90</b>	<b>90</b>	<b>90</b>
MAX. INLET PRESSURE [PSI] MP <sub>A</sub>	CONT.	[PSI]	[3625]	[3625]	[3625]	[3625]	[3625]	[3625]	[3625]	[3625]	
		<b>MP<sub>A</sub></b>	<b>25</b>	<b>25</b>	<b>25</b>	<b>25</b>	<b>25</b>	<b>25</b>	<b>25</b>	<b>25</b>	<b>25</b>
	INT.	[PSI]	[4350]	[4350]	[4350]	[4350]	[4350]	[4350]	[4350]	[4350]	[4350]
		<b>MP<sub>A</sub></b>	<b>30</b>	<b>30</b>	<b>30</b>	<b>30</b>	<b>30</b>	<b>30</b>	<b>30</b>	<b>30</b>	<b>30</b>
WEIGHT [LB] KG	[LB]	[22]	[22.4]	[23]	[24]	[24]	[26]	[27]	[29]	[31]	
	<b>KG</b>	<b>9.8</b>	<b>10</b>	<b>10.3</b>	<b>10.7</b>	<b>11.1</b>	<b>11.6</b>	<b>12.3</b>	<b>13.2</b>	<b>14.3</b>	

\* Continuous pressure:

\* Intermittent pressure:

\* Peak pressure:

Max. value of operating motor continuously.

Max. value of operating motor in 6 seconds per minute.

Max. value of operating motor in 0.6 second per minute.

## PERFORMANCE DATA

YMSY 80 [4.92 in<sup>3</sup>/rev] 80.6 cm<sup>3</sup>/rev.

		[508]	[1015]	[1523]	[2030]	[2538]	[3045]	[3263]	[PSI]
		3.5	7	10.5	14	17.5	20.5	22.5	MPa
GPM	[3.9]	[310]	[708]	[1061]	[1397]	[1725]	[2016]	[2202]	
	L/min	35	80	120	158	195	228	249	
L/min	15	<b>180</b>	<b>174</b>	<b>168</b>	<b>164</b>	<b>158</b>	<b>151</b>	<b>143</b>	TORQUE (LB-IN) TORQUE (N•M) SPEED (RPM)
	[7.9]	[310]	[708]	[1061]	[1397]	[1725]	[2016]	[2202]	
L/min	30	<b>362</b>	<b>352</b>	<b>346</b>	<b>338</b>	<b>330</b>	<b>322</b>	<b>310</b>	
	[10.6]	[310]	[699]	[1057]	[1311]	[1707]	[2008]	[2211]	
Flow (L/min)	40	<b>487</b>	<b>480</b>	<b>468</b>	<b>457</b>	<b>446</b>	<b>438</b>	<b>425</b>	
	[13.2]	[265]	[681]	[1035]	[1353]	[1698]	[1981]	[2193]	
Flow (L/min)	50	<b>612</b>	<b>603</b>	<b>592</b>	<b>581</b>	<b>572</b>	<b>558</b>	<b>542</b>	
	[15.9]	[248]	[681]	[1035]	[1353]	[1698]	[1981]	[2149]	
Flow (L/min)	60	<b>735</b>	<b>726</b>	<b>718</b>	<b>703</b>	<b>687</b>	<b>673</b>	<b>646</b>	
	[17.17]	[230]	[663]	[1026]	[1335]	[1663]	[1919]	[2087]	
Max cont.	65	<b>794</b>	<b>786</b>	<b>773</b>	<b>760</b>	<b>744</b>	<b>722</b>	<b>706</b>	Max cont.
Max int.	80	<b>981</b>	<b>968</b>	<b>955</b>	<b>925</b>	<b>893</b>	<b>870</b>	<b>832</b>	Max int.

YMSY 100 [6.15 in<sup>3</sup>/rev] 100.8 cm<sup>3</sup>/rev.

		[508]	[1015]	[1523]	[2030]	[2538]	[3045]	[3263]	[PSI]
		3.5	7	10.5	14	17.5	20.5	22.5	MPa
GPM	[3.9]	[425]	[840]	[1327]	[1769]	[2211]	[2494]	[2742]	
	L/min	48	95	150	200	250	282	310	
L/min	15	<b>146</b>	<b>144</b>	<b>139</b>	<b>135</b>	<b>130</b>	<b>120</b>	<b>105</b>	TORQUE (LB-IN) TORQUE (N•M) SPEED (RPM)
	[7.9]	[398]	[831]	[1291]	[1751]	[2211]	[2565]	[2804]	
L/min	30	<b>291</b>	<b>289</b>	<b>278</b>	<b>274</b>	<b>269</b>	<b>258</b>	<b>242</b>	
	[10.6]	[380]	[787]	[1256]	[1733]	[2193]	[2517]	[2795]	
Flow (L/min)	40	<b>387</b>	<b>384</b>	<b>374</b>	<b>359</b>	<b>350</b>	<b>335</b>	<b>320</b>	
	[13.2]	[354]	[778]	[1194]	[1716]	[2184]	[2529]	[2786]	
Flow (L/min)	50	<b>486</b>	<b>483</b>	<b>473</b>	<b>462</b>	<b>450</b>	<b>430</b>	<b>420</b>	
	[15.9]	[327]	[778]	[1167]	[1636]	[2158]	[2563]	[2759]	
Flow (L/min)	60	<b>588</b>	<b>584</b>	<b>574</b>	<b>562</b>	<b>550</b>	<b>538</b>	<b>520</b>	
	[19.8]	[310]	[708]	[1150]	[1592]	[2123]	[2467]	[2742]	
Max cont.	75	<b>740</b>	<b>735</b>	<b>720</b>	<b>705</b>	<b>696</b>	<b>676</b>	<b>653</b>	Max cont.
Max int.	90	<b>850</b>	<b>840</b>	<b>810</b>	<b>787</b>	<b>770</b>	<b>750</b>	<b>747</b>	Max int.

YMSY 125 [7.63 in<sup>3</sup>/rev] 125 cm<sup>3</sup>/rev.

		[508]	[1015]	[1523]	[2030]	[2538]	[3045]	[3263]	[PSI]
		3.5	7	10.5	14	17.5	20.5	22.5	MPa
GPM	[3.9]	[486]	[1061]	[1557]	[2167]	[2733]	[3051]	[3317]	
	L/min	55	120	176	245	309	345	375	
L/min	15	<b>115</b>	<b>113</b>	<b>110</b>	<b>104</b>	<b>98</b>	<b>90</b>	<b>84</b>	TORQUE (LB-IN) TORQUE (N•M) SPEED (RPM)
	[7.9]	[486]	[1061]	[1548]	[2241]	[2786]	[3219]	[3573]	
L/min	30	<b>231</b>	<b>228</b>	<b>225</b>	<b>214</b>	<b>202</b>	<b>188</b>	<b>172</b>	
	[10.6]	[469]	[1044]	[1574]	[2211]	[2786]	[3219]	[3564]	
Flow (L/min)	40	<b>312</b>	<b>309</b>	<b>290</b>	<b>289</b>	<b>278</b>	<b>262</b>	<b>235</b>	
	[13.2]	[442]	[1017]	[1557]	[2193]	[2784]	[3201]	[3511]	
Flow (L/min)	50	<b>391</b>	<b>386</b>	<b>378</b>	<b>365</b>	<b>352</b>	<b>339</b>	<b>308</b>	
	[15.9]	[398]	[999]	[1512]	[2131]	[2729]	[3166]	[3511]	
Flow (L/min)	60	<b>469</b>	<b>461</b>	<b>450</b>	<b>437</b>	<b>425</b>	<b>400</b>	<b>372</b>	
	[19.8]	[398]	[913]	[1477]	[2123]	[2706]	[3113]	[3440]	
Max cont.	75	<b>588</b>	<b>574</b>	<b>560</b>	<b>544</b>	<b>526</b>	<b>505</b>	<b>481</b>	Max cont.
Max int.	90	<b>710</b>	<b>696</b>	<b>680</b>	<b>661</b>	<b>646</b>	<b>628</b>	<b>610</b>	Max int.

YMSY 160 [9.4 in<sup>3</sup>/rev] 154 cm<sup>3</sup>/rev.

		[508]	[1015]	[1523]	[2030]	[2538]	[3045]	[3263]	[PSI]
		3.5	7	10.5	14	17.5	21	22.5	MPa
GPM	[3.9]	[619]	[1256]	[1901]	[2636]	[3290]	[3847]	[4210]	
	L/min	70	142	215	298	372	435	476	
L/min	15	<b>93</b>	<b>91</b>	<b>89</b>	<b>85</b>	<b>80</b>	<b>76</b>	<b>58</b>	TORQUE (LB-IN) TORQUE (N•M) SPEED (RPM)
	[7.9]	[646]	[1335]	[1990]	[2759]	[3378]	[4033]	[4351]	
L/min	30	<b>189</b>	<b>187</b>	<b>181</b>	<b>176</b>	<b>170</b>	<b>162</b>	<b>153</b>	
	[10.6]	[663]	[1344]	[2016]	[2777]	[3387]	[4015]	[4316]	
Flow (L/min)	40	<b>252</b>	<b>250</b>	<b>246</b>	<b>239</b>	<b>234</b>	<b>228</b>	<b>212</b>	
	[13.2]	[619]	[1309]	[1990]	[2697]	[3290]	[3936]	[4245]	
Flow (L/min)	50	<b>313</b>	<b>310</b>	<b>306</b>	<b>298</b>	<b>293</b>	<b>285</b>	<b>272</b>	
	[15.9]	[601]	[1265]	[1928]	[2618]	[3272]	[3909]	[4245]	
Flow (L/min)	60	<b>378</b>	<b>376</b>	<b>370</b>	<b>362</b>	<b>353</b>	<b>346</b>	<b>332</b>	
	[19.8]	[548]	[1238]	[1866]	[2574]	[3228]	[3883]	[4201]	
Max cont.	75	<b>475</b>	<b>469</b>	<b>461</b>	<b>450</b>	<b>441</b>	<b>432</b>	<b>414</b>	Max cont.
Max int.	90	<b>567</b>	<b>561</b>	<b>554</b>	<b>543</b>	<b>532</b>	<b>520</b>	<b>509</b>	Max int.

## PERFORMANCE DATA

YMSY 200 [11.8 in<sup>3</sup>/rev] 194 cm<sup>3</sup>/rev. Max cont. Max int.

		[508]	[1015]	[1523]	[2030]	[2538]	[3045]	[3263]	[PSI]
		3.5	7	10.5	14	17.5	21	22.5	MPa
GPM	[3.9]	[769]	[1583]	[2414]	[3281]	[4166]	[4970]	[5395]	
	L/min	87	179	273	371	471	562	610	
15	[7.9]	[805]	[1680]	[2547]	[3414]	[4325]	[5059]	[5466]	TORQUE [LB-IN] TORQUE (N•M) SPEED (RPM)
	30	91	190	288	386	489	572	618	
Flow (L/min)	[10.6]	[831]	[1707]	[2618]	[3485]	[4404]	[5165]	[5704]	
	40	94	193	296	394	498	584	645	
50	[13.2]	[796]	[1689]	[2582]	[3440]	[4360]	[5130]	[5607]	
	60	90	191	292	389	493	580	634	
Max cont.	[15.9]	[752]	[1636]	[2467]	[3378]	[4272]	[5085]	[5501]	Max cont.
	75	85	185	279	382	483	575	622	
Max int.	[19.8]	[690]	[1557]	[2397]	[3272]	[4174]	[4961]	[5395]	Max int.
	90	78	176	271	370	472	561	610	
	[23.8]	[601]	[1442]	[2344]	[3193]	[4033]	[4820]	[5298]	
	90	68	163	265	361	456	545	599	

YMSY 250 [14.8 in<sup>3</sup>/rev] 243 cm<sup>3</sup>/rev. Max cont. Max int.

		[508]	[1015]	[1523]	[2030]	[2537]	[2900]	[3262]	[PSI]
		3.5	7	10.5	14	17.5	20	22.5	MPa
GPM	[3.9]	[773]	[2043]	[3104]	[4086]	[5174]	[6023]	[6881]	
	L/min	110	231	351	462	585	681	778	
15	[7.9]	[1026]	[2087]	[3175]	[4201]	[5280]	[6191]	[6987]	TORQUE [LB-IN] TORQUE (N•M) SPEED (RPM)
	30	116	236	359	475	597	700	790	
Flow (L/min)	[10.6]	[1044]	[2131]	[3210]	[4245]	[5298]	[6244]	[7040]	
	40	118	241	363	480	599	706	796	
50	[13.2]	[982]	[2069]	[3113]	[4174]	[5227]	[6129]	[6969]	
	60	111	234	352	472	591	693	788	
Max cont.	[15.9]	[937]	[1981]	[3051]	[4086]	[5147]	[6058]	[6828]	Max cont.
	75	106	224	345	462	582	685	772	
Max int.	[19.8]	[893]	[1893]	[3007]	[4015]	[5041]	[5925]	[6721]	Max int.
	90	101	214	340	454	570	670	760	
	[23.8]	[822]	[1848]	[2963]	[3953]	[4944]	[5811]	[6624]	
	90	93	209	335	447	559	657	749	

YMSY 315 [18.9 in<sup>3</sup>/rev] 311 cm<sup>3</sup>/rev. Max cont. Max int.

		[508]	[1015]	[1522]	[2030]	[2537]	[2900]	[3262]	[PSI]
		3.5	7	10.5	14	17.5	20	22.5	MPa
GPM	[3.9]	[1309]	[2689]	[4033]	[5421]	[6739]	[7774]	[8649]	
	L/min	148	304	456	613	762	879	978	
15	[7.9]	[1371]	[2777]	[4112]	[5616]	[6881]	[7818]	[8738]	TORQUE [LB-IN] TORQUE (N•M) SPEED (RPM)
	30	155	314	465	635	778	884	988	
Flow (L/min)	[10.6]	[1415]	[2839]	[4236]	[5749]	[7040]	[8013]	[8817]	
	40	160	321	479	650	796	906	997	
50	[13.2]	[1371]	[2777]	[4112]	[5642]	[6898]	[7836]	[8738]	
	60	155	314	465	638	780	886	988	
Max cont.	[15.9]	[1535]	[2706]	[4006]	[5483]	[6766]	[7836]	[8632]	Max cont.
	75	151	306	453	620	765	886	976	
Max int.	[19.8]	[1291]	[2653]	[3936]	[5421]	[6677]	[7739]	[8543]	Max int.
	90	146	300	445	613	755	875	966	
	[23.8]	[1194]	[2512]	[3856]	[5315]	[6545]	[7632]	[8419]	
	90	135	284	436	601	740	863	952	

YMSY 400 [24.0 in<sup>3</sup>/rev] 394 cm<sup>3</sup>/rev. Max cont. Max int.

		[508]	[1015]	[1523]	[2030]	[2320]	[2538]	[PSI]
		3.5	7	10.5	14	16	17.5	MPa
GPM	[3.9]	[1645]	[3352]	[5112]	[6889]	[7924]	[8720]	
	L/min	186	379	578	779	896	986	
15	[7.9]	[1680]	[3431]	[5218]	[6996]	[8004]	[8764]	TORQUE [LB-IN] TORQUE (N•M) SPEED (RPM)
	30	190	388	590	791	905	991	
Flow (L/min)	[10.6]	[1725]	[3485]	[5271]	[7049]	[8066]	[8826]	
	40	195	394	596	797	912	998	
50	[13.2]	[1689]	[3431]	[5191]	[6943]	[7995]	[8694]	
	60	191	388	587	785	904	983	
Max cont.	[15.9]	[1645]	[3431]	[5191]	[6943]	[7995]	[8694]	Max cont.
	75	186	388	587	785	904	983	
Max int.	[19.8]	[1601]	[3290]	[5094]	[6810]	[7880]	[8605]	Max int.
	90	181	372	576	770	891	973	
	[23.8]	[1557]	[3246]	[5050]	[6775]	[7809]	[8534]	
	90	176	367	571	766	883	965	

## PERFORMANCE DATA

YMSY 475 [28.9 in<sup>3</sup>/rev] 475 cm<sup>3</sup>/rev. Max cont. Max int.

	[508]	[1015]	[1523]	[2030]	[2538]	[PSI]
	3.5	7	10.5	14	17.5	MPa
GPM	[3.9]	[1928]	[3883]	[5843]	[7889]	[8800]
L/min	15	218	439	661	892	995
	[7.9]	[1972]	[3980]	[5979]	[8048]	[8862]
	30	223	450	676	910	1002
		<b>61</b>	<b>60</b>	<b>58</b>	<b>56</b>	<b>53</b>
	[10.6]	[2016]	[4077]	[6094]	[8198]	[8994]
	40	228	461	689	927	1017
		<b>82</b>	<b>80</b>	<b>77</b>	<b>74</b>	<b>68</b>
	[13.2]	[1981]	[4033]	[6032]	[8136]	[8915]
	50	224	456	682	920	1008
		<b>103</b>	<b>101</b>	<b>97</b>	<b>92</b>	<b>86</b>
	[15.9]	[1946]	[3989]	[5987]	[8075]	[8826]
	60	220	451	677	913	998
		<b>123</b>	<b>121</b>	<b>118</b>	<b>112</b>	<b>105</b>
Max cont.	[19.8]	[1875]	[3918]	[5872]	[7968]	[8667]
	75	212	443	664	901	980
		<b>155</b>	<b>153</b>	<b>147</b>	<b>140</b>	<b>132</b>
Max int.	[23.8]	[1733]	[3723]	[5687]	[7756]	[8481]
	90	196	421	643	877	959
		<b>186</b>	<b>184</b>	<b>178</b>	<b>170</b>	<b>157</b>

TORQUE [LB-IN]  
TORQUE (N•M)  
SPEED (RPM)

Max cont.  
Max int.

## MOUNTING DATA

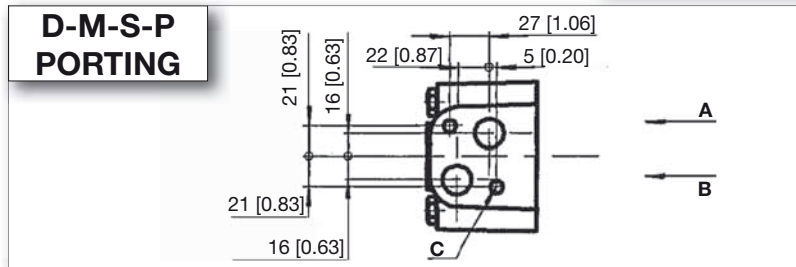
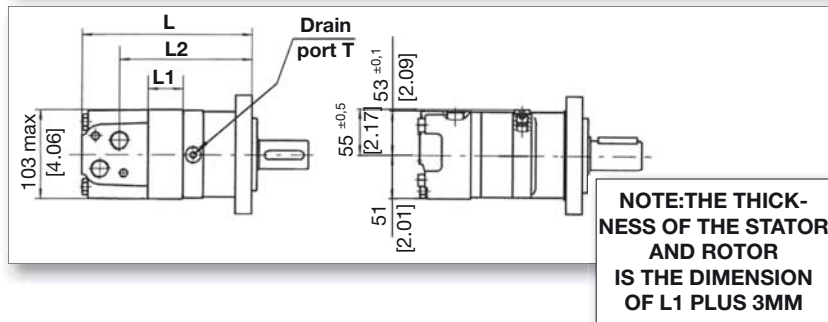

### PORT & DRAIN PORT ORDERING CODES

ORDER CODE	D depth	M depth	S depth	P depth
PORTS - A AND B	G 1/2	M 22 x 1.5	7/8-14 O-ring	1/2-14 NPT
	18 mm	18 mm	18 mm	15 mm
TANK PORT - T	G 1/4	M 14 x 1.5	7/16-20UNF	7/16-20 UNF
	12 mm	12 mm	12 mm	12 mm
BOLTS-C	2-M10	2-M10	2-3/8-16 unc	2-3/8-16 unc
	13 mm	13 mm	13 mm	13 mm

MODEL	[INCHES]			MILLIMETERS		
	L	L1	L2	L	L1	L2
YMSY 80	[6.69]	[0.63]	[4.98]	170	16	126.5
YMSY 100	[6.85]	[0.79]	[5.14]	174	20	130.5
YMSY 125	[7.05]	[0.98]	[5.33]	179	25	135.5
YMSY 160	[7.15]	[1.09]	[5.43]	181.5	27.5	137.7
YMSY 200	[7.44]	[1.39]	[5.72]	189	35.1	145.2
YMSY 250	[7.92]	[1.85]	[6.19]	201	47	157.2
YMSY 315	[8.39]	[2.33]	[6.67]	213	59	169.2
YMSY 400	[8.78]	[2.72]	[7.07]	223	69	179.5
YMSY 475	[9.33]	[3.27]	[7.22]	237	83	183.5

MODEL	[INCHES]			MILLIMETERS		
	L	L1	L2	L	L1	L2
YMSY 80 W	[5.22]	[0.63]	[3.50]	132.5	16	89
YMSY 100 W	[5.37]	[0.79]	[3.66]	136.5	20	93
YMSY 125 W	[5.57]	[0.98]	[3.86]	141.5	25	98
YMSY 160 W	[5.67]	[1.08]	[3.96]	143.9	27.5	100.5
YMSY 200 W	[5.96]	[1.38]	[4.25]	151.4	35.1	108
YMSY 250 W	[6.43]	[1.85]	[4.72]	163.4	47	120
YMSY 315 W	[6.91]	[2.32]	[5.20]	175.4	59	132
YMSY 400 W	[7.30]	[2.72]	[5.59]	185.5	69	142
YMSY 475 W	[7.85]	[3.27]	[6.14]	199.5	83	156

## MOUNTING DATA

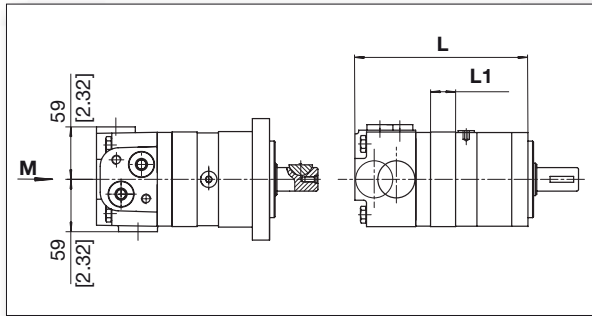

MODEL	[INCHES]		MILLIMETERS	
	L	L1	L	L1
YMSY 80	[6.93]	[0.63]	176	16
YMSY 100	[7.09]	[0.79]	180	20
YMSY 125	[7.28]	[0.98]	185	25
YMSY 160	[7.36]	[1.06]	187	27
YMSY 200	[7.64]	[1.34]	194	34
YMSY 250	[7.95]	[1.65]	202	42
YMSY 315	[8.43]	[2.13]	214	54
YMSY 400	[9.02]	[2.72]	229	69
YMSY 475	[9.57]	[3.27]	243	83

MODEL	[INCHES]		MILLIMETERS	
	L	L1	L	L1
YMSY 80 WE	[5.83]	[0.63]	148	16
YMSY 100 WE	[5.98]	[0.79]	152	20
YMSY 125 WE	[6.18]	[0.98]	157	25
YMSY 160 WE	[6.26]	[1.06]	159	27
YMSY 200 WE	[6.54]	[1.34]	166	34
YMSY 250 WE	[6.85]	[1.65]	174	42
YMSY 315 WE	[7.32]	[2.13]	186	54
YMSY 400 WE	[7.91]	[2.72]	201	69
YMSY 475 WE	[8.46]	[3.27]	215	83

### PORTING END PORTS

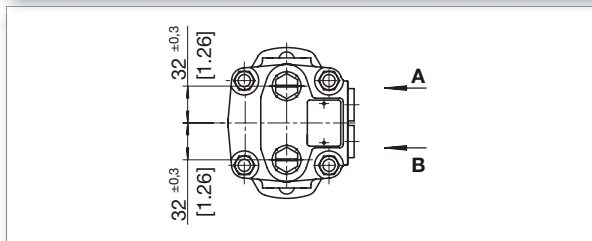

### PORT & DRAIN PORT ORDERING CODES

ORDER CODE	EE-D depth	EE-M2 depth	EE-S2 depth
PORTS - A AND B	G 1/2 18 mm	M22x1.5 - 18 mm	7/8-14 O-ring 18 mm
TANK PORT - T	G 1/4 12 mm	M14x1.5 - 12 mm	7/16-20 UNF 12 mm

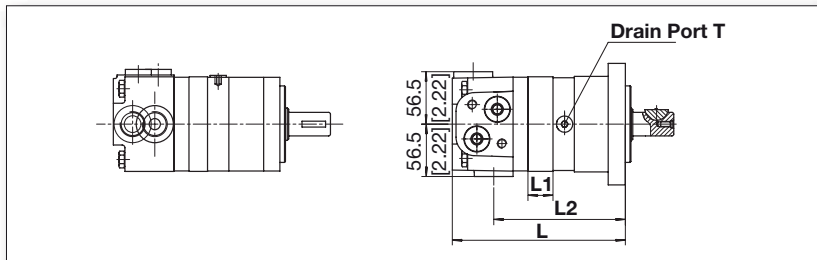

MODEL	[INCHES]			MILLIMETERS		
	L	L1	L2	L	L1	L2
YMSY 80	[6.93]	[0.63]	[5.12]	176	16	130
YMSY 100	[7.09]	[0.79]	[5.28]	180	20	134
YMSY 125	[7.28]	[0.98]	[5.47]	185	25	139
YMSY 160	[7.36]	[1.06]	[5.55]	187	27	141
YMSY 200	[7.64]	[1.34]	[5.83]	194	34	148
YMSY 250	[7.95]	[1.65]	[6.14]	202	42	156
YMSY 315	[8.43]	[2.13]	[6.61]	214	54	168
YMSY 400	[9.02]	[2.72]	[7.20]	229	69	183
YMSY 475	[9.57]	[3.27]	[7.76]	243	83	197

### ED PORTING 180° PORTS

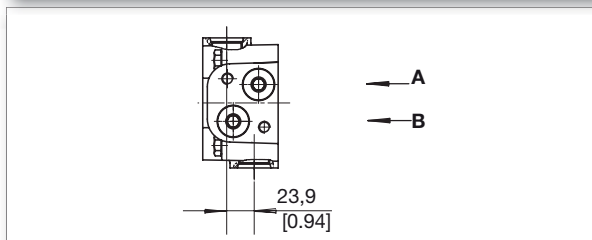

### PORT & DRAIN PORT ORDERING CODES

ORDER CODE	ED depth
PORTS - A AND B	1-1/16-12 UN O-ring 18 mm
T	7/16-20 UNF 12 mm

MODEL	[INCHES]			MILLIMETERS		
	L	L1	L2	L	L1	L2
YMSY 80	[5.83]	[0.63]	[4.02]	148	16	102
YMSY 100	[5.98]	[0.79]	[4.17]	152	20	106
YMSY 125	[6.18]	[0.98]	[4.37]	157	25	111
YMSY 160	[6.26]	[1.06]	[4.45]	159	27	113
YMSY 200	[6.54]	[1.34]	[4.69]	166	34	119
YMSY 250	[7.01]	[1.65]	[5.00]	178	42	127
YMSY 315	[7.48]	[2.13]	[5.47]	190	54	139
YMSY 400	[8.07]	[2.72]	[6.06]	205	69	154
YMSY 475	[8.62]	[3.27]	[6.61]	219	83	168

## MOUNTING DATA

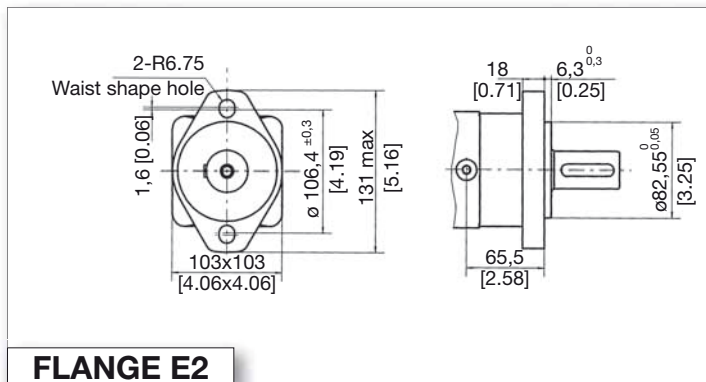

**FLANGE E2**

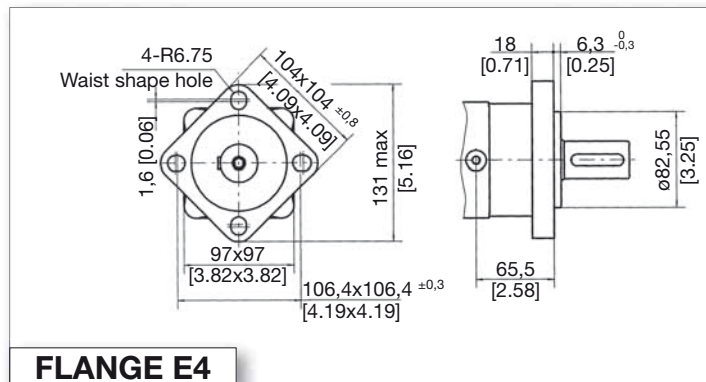

**FLANGE E4**

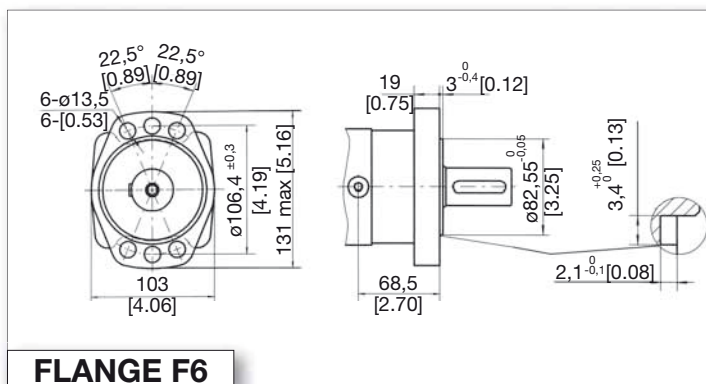

**FLANGE F6**

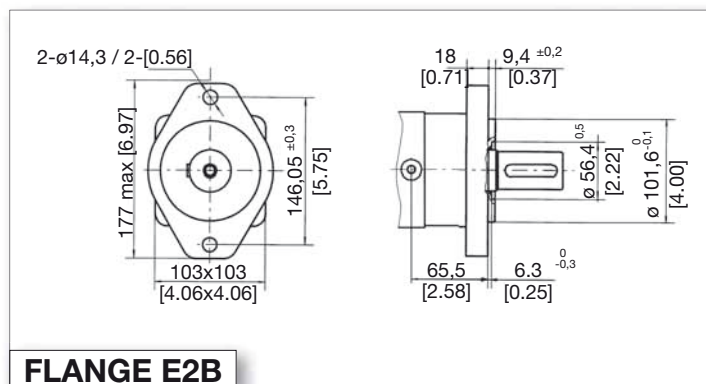

**FLANGE E2B**

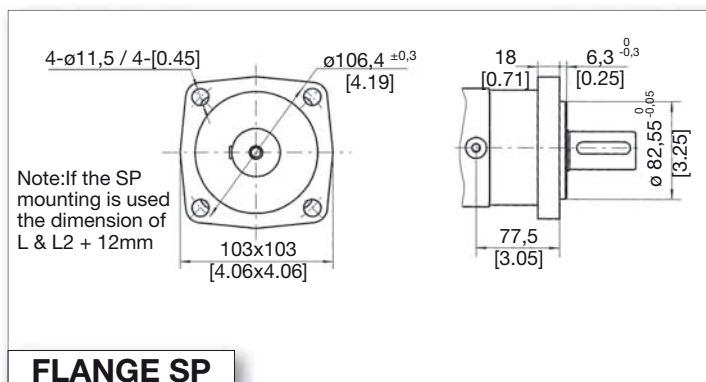

**FLANGE SP**

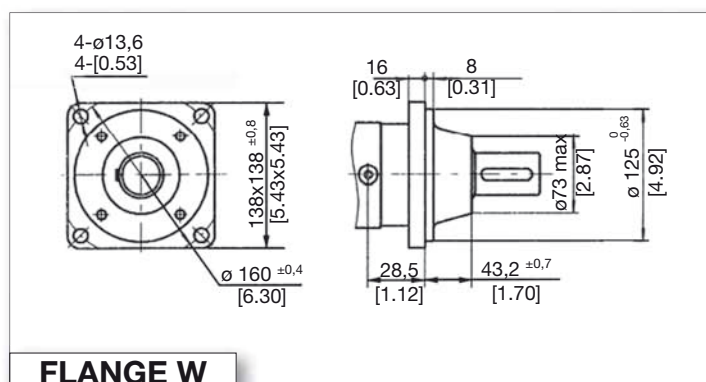

**FLANGE W**

## MOTOR SHAFT EXTENSIONS

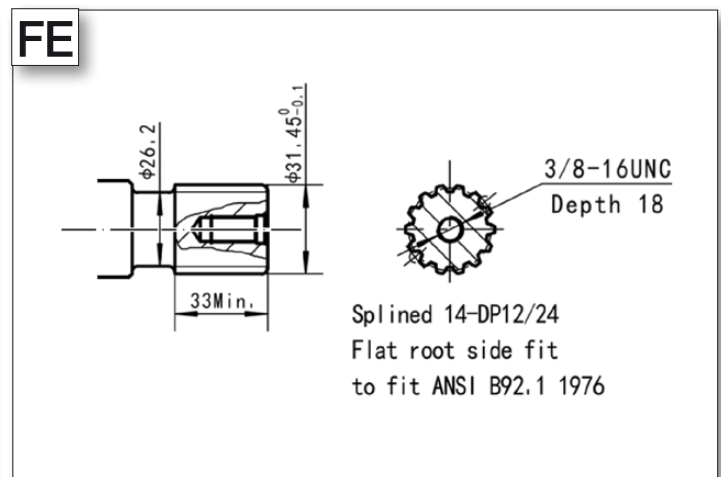
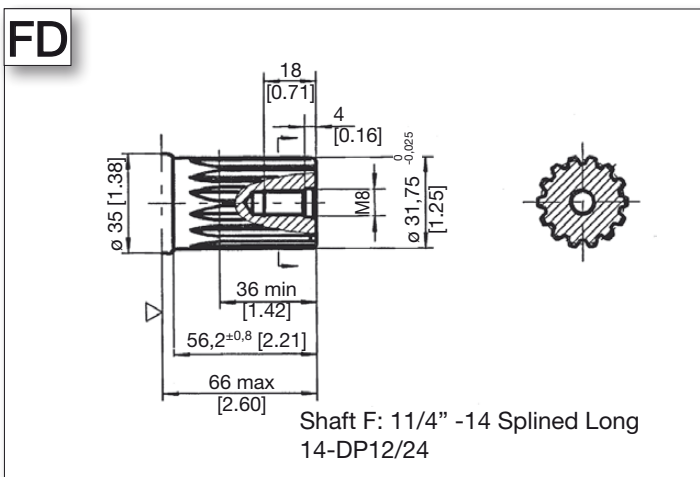
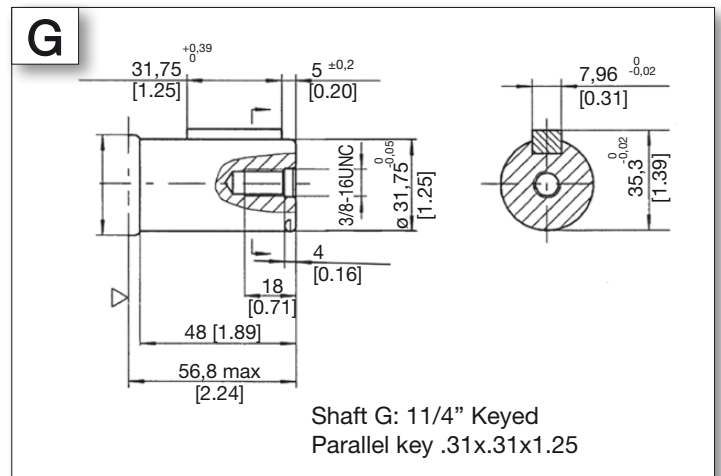
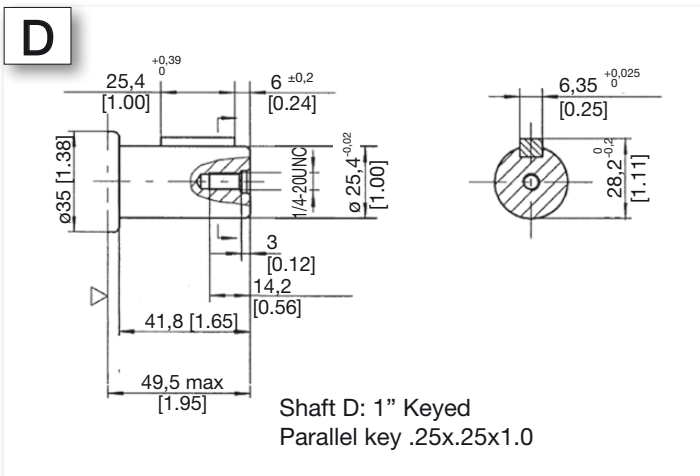
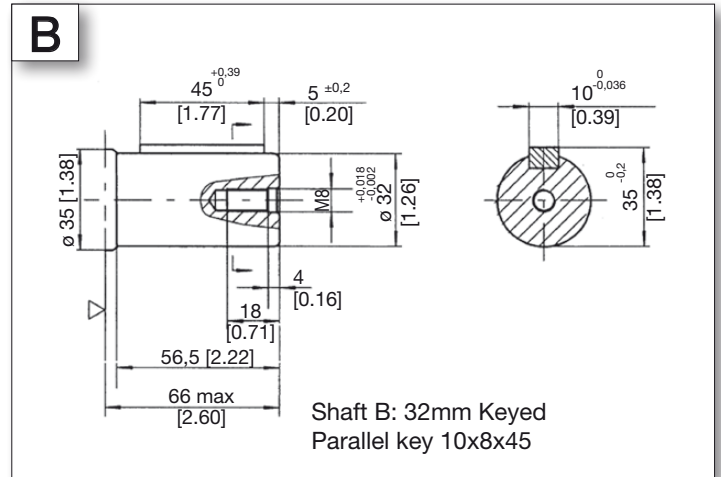
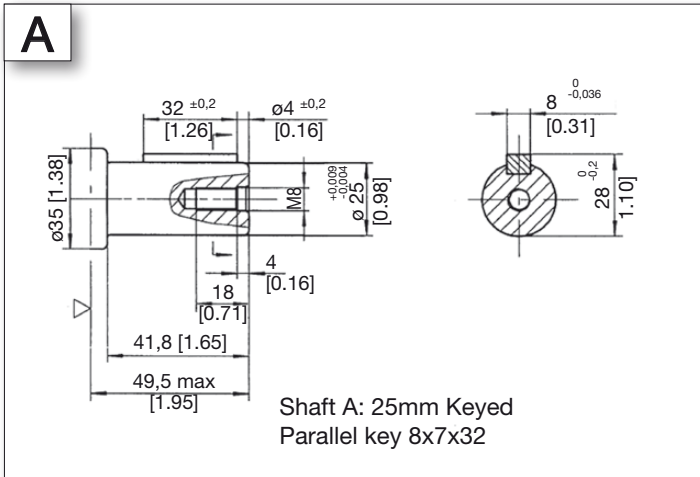

## MOTOR SHAFT EXTENSIONS

**S1**

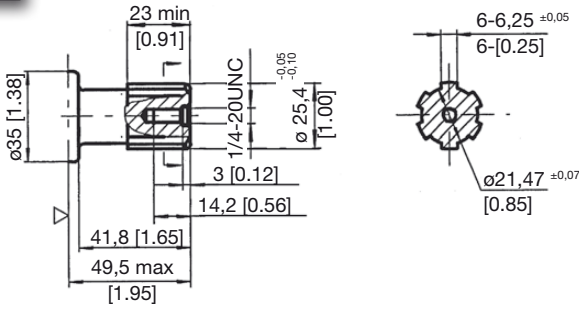

Shaft S1: Splined SAE 6B

**T1**

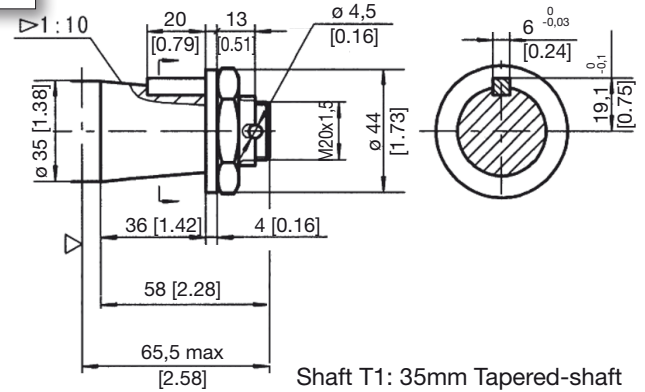

Shaft T1: 35mm Tapered-shaft  
Parallel key B6x6x20

**T3**

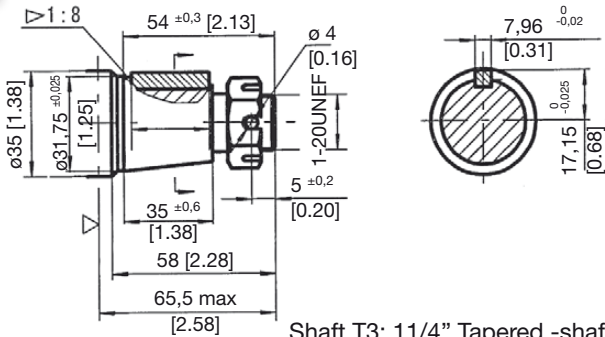

Shaft T3: 11/4" Tapered -shaft  
Parallel key .31x.31x11/4  
Tightening torque:200±10Nm

**F**

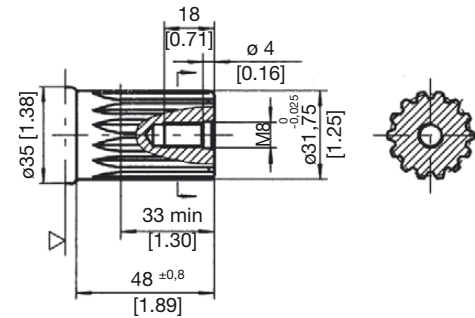

Shaft F : 11/4" 14 Splined Take out  
14-DP12/24

**I**

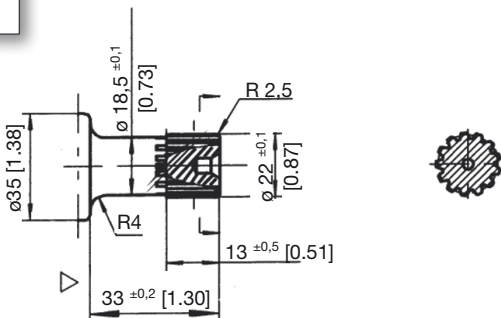

Shaft I: 7/8" 13 Splined  
13-DP16/32

**SL**

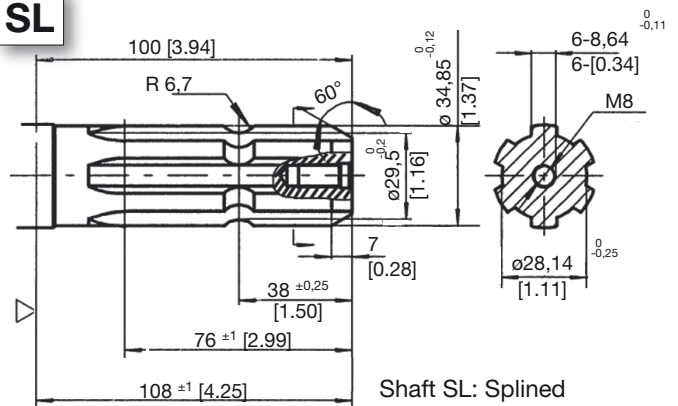

Shaft SL: Splined  
6-34.85x28.14x8.64



## ADDITIONAL DATA

### PERMISSIBLE SHAFT SEAL PRESSURE

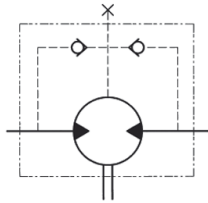

Note: Curve 1 for standard shaft seal  
Curve 2 for high pressure shaft seal

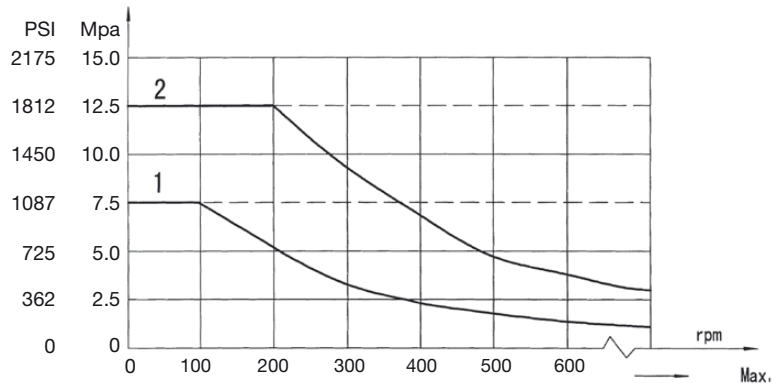

IN APPLICATIONS WITHOUT A DRAIN LINE, THE PRESSURE EXERTED ON THE SHAFT SEAL WILL EXCEED THE PRESSURE IN THE RETURN LINE. IN APPLICATIONS USING A DRAIN LINE, THE PRESSURE ON THE OUTPUT SHAFT SEAL CAN EQUAL THE PRESSURE IN DRAIN LINE.

### DIRECTION OF SHAFT ROTATION

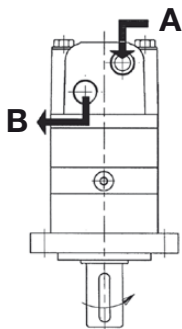

YMSY

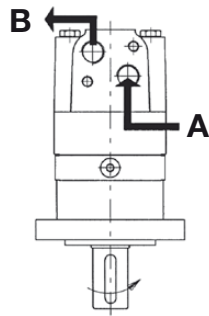

YMSY

### AXIAL AND RADIAL FORCES

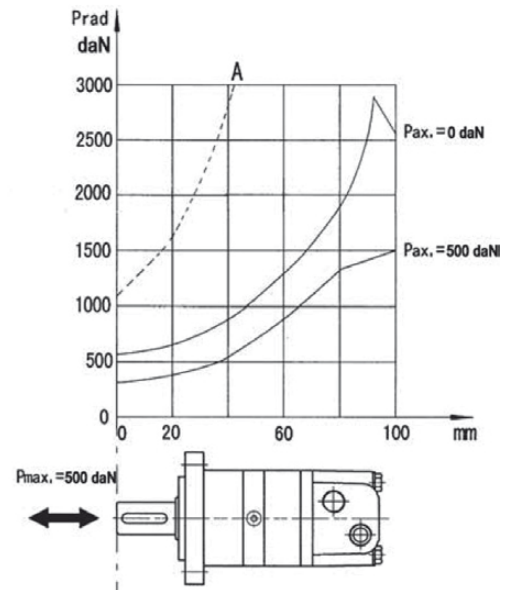

When viewing the motor from the output shaft end, port A is defined to be on the right and port B is defined to be on the left side. Standard rotation motors rotate CW when port A is pressurized. The motors are bi-directional and CCW rotation occurs when port B is pressurized.

Reverse rotation motors can special ordered which will operate with opposite rotation outlined above.

## ORDERING INFORMATION

1	2	3	4	5	6	7
YMSY						

1	2		3		4		5		6		7	
DISP.	FLANGE		OUTPUT SHAFT		PORT AND DRAIN PORT		ROTATION DIRECTION		PAINT		SPECIAL OPTIONS	
80	E2	SAE 2-Bolt , pilot 3.25x.25	A	Shaft :25mm Keyed, parallel Key 8x7x32	D	G1/2 Manifold Mount 2-M10, G1/4	NONE	STANDARD	OO	NO PAINT	NONE	STANDARD
100	E4	4- Bolt flange, pilot 3.25x.25	B	Shaft: 32mm Keyed parallel Key 10x8x45	M	M22x1.5 Manifold Mount 2-M10, M14x1.5	R	OPPOSITE			FR	FREE RUNNING
125	F6	Magneto flange, pilot 3.25x.25	D	Shaft: 1" Keyed parallel Key .25x.25x1.0	S	7/8-14 O-ring manifold 2-3/8-16 UNC, 7/16-20UNF			B	BLACK		
160	SP	4 Bolt-flange, pilot 3.25x.25	G	Shaft: 11/4" Keyed parallel Key .31x.31x1.25	P	1/2-14 NPTF Manifold 2-3/8-16 UNC, 7/16-20UNF						
200	W	4-Ø13.5 Wheel-flange, pilot Ø125x8	F	Shaft: 11/4-14,splined 14-DP12/24	EE M2	M22X1,5 M14X1,5					CRS	CORROSION RESISTANT SHAFT
250	E2B	SAE B 2-Bolt pilot 4.00x.37	FD	Long Shaft: 11/4-14 splined splined14-DP12/24	EE S2	7/8-14 UNF O-ring 7/16-20 UNF					HPS	HIGH PRESSURE SEAL
315			SL	Shaft Ø34.85 ,Splined 6-34.85x28.14x8.64	ED	1-1/16-12 UF O-ring, 7/16-20 UNF					HTS	HIGH TEMP SEAL
400			T1	35mm Tapered parallel key b6x6x20								
475			T3	shaft: 11/4 Tape-red parallel Key .31x.31x1.250								
			S1	Shaft :SAE-6 B splined								
			I	Shaft: 7/8-13 splined 13-DP16/32								

**ORDERING CODE:**

All options have been determined with letters, numbers or combinations. All boxes must be filled with proper codes. If specification is not in the table, please contact us with your requirements.

# YMSE



The **YMSE** series motors incorporates the advanced **GEROLOR** gear set which reduces internal friction to a minimum. A “DISC VALVE” distribution system which is internally balanced to reduce friction, leakage and permits better speed control producing higher efficiency, smoother rotation, higher speed and pressure.

The series has many sizes and options to make it very flexible for many applications. The output shaft is mounted on tapered roller bearings for high radial and axial load for very high duty applications

## SPECIFICATIONS

Distribution Type	Model	Displacement		Max. Operating Pressure		Speed Range Continuous	Max. Output Power	
		[in <sup>3</sup> ./rev]	[4.88 ~ 22.88]	[PSI]	[3263]		[HP]	[27]
Disc Distribution	YMSE	cm <sup>3</sup> /rev.	80 ~ 370	MPa	22.5	30 ~ 800	Kw	20

## QUICK REFERENCE GUIDE

### YMSE SERIES QUICK REFERENCE:

Displacements				
[in <sup>3</sup> ./rev]	cm <sup>3</sup> /rev.			
[4.92]	80.6	FLOW UP TO	90 LPM	[23.78 GPM]
[6.15]	100.8	PRESSURE UP TO	22.5 MPA	[3262 PSI]
[7.63]	125	TORQUE UP TO	751 NM	[3944 LB. IN.]
[9.59]	157.2	SPEED UP TO	446 RPM	
[12.2]	200			
[15.38]	252			
[19.19]	314.5			
[22.57]	370			

**Shaft Seals:** Standard high pressure shaft seals permit applications in series or without drain line when required

**Low Speed Valving:** These motors are manufactured following strict procedures to reduce tolerances between all components to permit lower speed, higher efficiency and smoother rotation at very low speeds. These motors are not for high speed or low pressure applications.

**Free Running:** Motors with this option have increased clearances in the rotor set. This allows improved mechanical efficiency, longer life and better performance for high-speed / high-flow applications, winch or similar applications where the motor is cross-ported to allow manual free turning also remay benefit from this option to allow smoother easier free turning of the motor. Last, applications which have many reversals or high pressure spikes can also benefit since the pressure spikes will be reduced by relieving (cross-ported) such spikes internally in the motor. The trade off of these benefits is a slight reduction in volumetric efficiency, particularly at high pressure conditions.

**Special Motors:** These motors have special options like nickel plated shafts or housings for applications in corrosive environments.

### APPLICATION GUIDELINES:

For optimum results the following working conditions are recommended:

- \* Oil temperature should be between 20° - 60° C [68° - 180° F]
- \* Oil filter of 10 - 20 micron
- \* Oil viscosity 42 - 74 mm<sup>2</sup>/s CSA at 40° C
- \* Different shafts are used when there is a radial load or not. Check data pages
- \* For longer life we suggest the motor at start up, run for a shorter period of time (one hour) at no more than 30% of rated speed and pressure.

## SPECIFICATION DATA

For individual motor performance charts consult equivalent YMS series data

DISTRIBUTION TYPE		YMSE 80	YMSE 100	YMSE 125	YMSE 160	YMSE 200	YMSE 250	YMSE 315	YMSE 375	
GEOMETRIC DISPLACEMENT	[in <sup>3</sup> ./rev.]	[4.92]	[6.16]	[7.63]	[9.60]	[12.21]	[15.38]	[19.20]	[22.58]	
	cm <sup>3</sup> /rev.	80.6	100.8	125	157.2	200	252	314.5	370	
MAX. SPEED RPM	CONT.	800	748	600	470	375	300	240	200	
	INT.	<b>988</b>	<b>900</b>	<b>720</b>	<b>560</b>	<b>450</b>	<b>360</b>	<b>280</b>	<b>240</b>	
MAX. TORQUE [LB. IN.] N*M	CONT.	[LB. IN.]	[1680]	[2123]	[2742]	[2795]	[3538]	[3980]	[4953]	[4740]
		<b>N*M</b>	<b>190</b>	<b>240</b>	<b>310</b>	<b>316</b>	<b>400</b>	<b>450</b>	<b>560</b>	<b>536</b>
	INT.	[LB. IN.]	[2123]	[2653]	[3272]	[3803]	[4121]	[4776]	[5819]	[5704]
		<b>N*M</b>	<b>240</b>	<b>300</b>	<b>370</b>	<b>430</b>	<b>466</b>	<b>540</b>	<b>659</b>	<b>645</b>
	PEAK	[LB. IN.]	[2299]	[2830]	[3538]	[4174]	[5749]	[6102]	[6545]	[6642]
		<b>N*M</b>	<b>260</b>	<b>320</b>	<b>400</b>	<b>472</b>	<b>650</b>	<b>690</b>	<b>740</b>	<b>751</b>
MAX. OUTPUT [HP] KW	CONT.	[HP]	[21]	[25]	[26]	[21]	[21]	[19]	[19]	[16]
		<b>KW</b>	<b>15.9</b>	<b>18.</b>	<b>19.5</b>	<b>15.6</b>	<b>15.7</b>	<b>14.1</b>	<b>14.1</b>	<b>11.8</b>
	INT.	[HP]	[27]	[32]	[32]	[29]	[25]	[23]	[25]	[23]
		<b>KW</b>	<b>20.1</b>	<b>23.5</b>	<b>23.2</b>	<b>21.2</b>	<b>18.3</b>	<b>17.0</b>	<b>18.9</b>	<b>17</b>
MAX. PRES-SURE DROP [PSI] MPa	CONT.	[PSI]	[2538]	[2538]	[2538]	[2175]	[2030]	[1813]	[1740]	[1450]
		<b>MPa</b>	<b>17.5</b>	<b>17.5</b>	<b>17.5</b>	<b>15</b>	<b>14</b>	<b>12.5</b>	<b>12</b>	<b>10</b>
	INT.	[PSI]	[3045]	[3045]	[3045]	[3045]	[2320]	[2320]	[2030]	[1740]
		<b>MPa</b>	<b>21</b>	<b>21</b>	<b>21</b>	<b>21</b>	<b>16</b>	<b>16</b>	<b>14</b>	<b>12</b>
	PEAK	[PSI]	[3263]	[3263]	[3263]	[3263]	[3263]	[2900]	[2683]	[2030]
		<b>MPa</b>	<b>22.5</b>	<b>22.5</b>	<b>22.5</b>	<b>22.5</b>	<b>22.5</b>	<b>20</b>	<b>18.5</b>	<b>14</b>
MAX. FLOW [GPM] L/MIN	CONT.	[GPM]	[17.1]	[19.8]	[19.8]	[19.8]	[19.8]	[19.8]	[19.8]	[19.8]
		<b>L/MIN</b>	<b>65</b>	<b>75</b>	<b>75</b>	<b>75</b>	<b>75</b>	<b>75</b>	<b>75</b>	<b>75</b>
	INT.	[GPM]	[21.1]	[23.7]	[23.7]	[23.]	[23.7]	[23.7]	[23.7]	[23.7]
		<b>L/MIN</b>	<b>80</b>	<b>90</b>	<b>90</b>	<b>90</b>	<b>90</b>	<b>90</b>	<b>90</b>	<b>90</b>
MAX. INLET PRESSURE [PSI] MPa	CONT.	[PSI]	[3625]	[3625]	[3625]	[3625]	[3625]	[3625]	[3625]	[3625]
		<b>MPa</b>	<b>25</b>	<b>25</b>	<b>25</b>	<b>25</b>	<b>25</b>	<b>25</b>	<b>25</b>	<b>25</b>
	INT.	[PSI]	[4350]	[4350]	[4350]	[4350]	[4350]	[4350]	[4350]	[4350]
		<b>MPa</b>	<b>30</b>	<b>30</b>	<b>30</b>	<b>30</b>	<b>30</b>	<b>30</b>	<b>30</b>	<b>30</b>
WEIGHT [LB] KG	[LB]	[22]	[22]	[23]	[24]	[24]	[26]	[27]	[28]	
	<b>KG</b>	<b>9.8</b>	<b>10</b>	<b>10.3</b>	<b>10.7</b>	<b>11.1</b>	<b>11.6</b>	<b>12.3</b>	<b>12.6</b>	

\* Continuous pressure:

Max. value of operating motor continuously.

\* Intermittent pressure:

Max. value of operating motor in 6 seconds per minute.

\* Peak pressure:

Max. value of operating motor in 0.6 second per minute.

## PERFORMANCE DATA

YMSE 80

		[4.92 in <sup>3</sup> /rev] 80.6 cm <sup>3</sup> /rev.				Max cont.	Max int.		
		[507]	[1015]	[1522]	[2030]	[2537]	[3045]	[3262]	
		3.5	7	10.5	14	17.5	21	22.5	
									[PSI]
									MPa
GPM	[3.9]	[310]	[707]	[1061]	[1397]	[1724]	[2078]	[2202]	TORQUE (LB-IN) TORQUE (N•M) SPEED (RPM)
	L/min	35	80	120	158	195	235	249	
Flow (L/min)	[7.9]	[310]	[707]	[1061]	[1397]	[1724]	[2122]	[2299]	TORQUE (LB-IN) TORQUE (N•M) SPEED (RPM)
	15	<b>180</b>	<b>174</b>	<b>168</b>	<b>164</b>	<b>158</b>	<b>151</b>	<b>143</b>	
Flow (L/min)	[30]	[310]	[707]	[1061]	[1397]	[1724]	[2122]	[2299]	TORQUE (LB-IN) TORQUE (N•M) SPEED (RPM)
	30	<b>362</b>	<b>352</b>	<b>346</b>	<b>338</b>	<b>330</b>	<b>322</b>	<b>310</b>	
Flow (L/min)	[10.6]	[310]	[699]	[1052]	[1371]	[1707]	[2070]	[2211]	TORQUE (LB-IN) TORQUE (N•M) SPEED (RPM)
	40	<b>482</b>	<b>473</b>	<b>464</b>	<b>453</b>	<b>444</b>	<b>434</b>	<b>415</b>	
Flow (L/min)	[13.2]	[265]	[681]	[1035]	[1353]	[1698]	[2052]	[2193]	TORQUE (LB-IN) TORQUE (N•M) SPEED (RPM)
	50	<b>602</b>	<b>594</b>	<b>587</b>	<b>569</b>	<b>560</b>	<b>551</b>	<b>522</b>	
Max cont.	[15.8]	[248]	[681]	[1035]	[1353]	[1698]	[2052]	[2184]	Max cont.
	60	<b>724</b>	<b>713</b>	<b>707</b>	<b>683</b>	<b>673</b>	<b>664</b>	<b>629</b>	
Max int.	[19.8]	[221]	[663]	[1008]	[1344]	[1680]	[2034]	[2167]	Max int.
	75	<b>840</b>	<b>832</b>	<b>817</b>	<b>796</b>	<b>786</b>	<b>777</b>	<b>737</b>	
Max int.	[23.8]	[212]	[646]	[973]	[1327]	[1636]	[1990]	[2123]	Max int.
	90	<b>900</b>	<b>893</b>	<b>872</b>	<b>853</b>	<b>843</b>	<b>834</b>	<b>792</b>	

YMSE 100

		[6.16 in <sup>3</sup> /rev] 100.8 cm <sup>3</sup> /rev.				Max cont.	Max int.		
		[507]	[1015]	[1522]	[2030]	[2537]	[3045]	[3262]	
		3.5	7	10.5	14	17.5	21	22.5	
									[PSI]
									MPa
GPM	[3.9]	[425]	[840]	[1327]	[1769]	[2211]	[2556]	[2742]	TORQUE (LB-IN) TORQUE (N•M) SPEED (RPM)
	L/min	48	95	150	200	250	289	310	
Flow (L/min)	[7.9]	[398]	[831]	[1291]	[1751]	[2211]	[2609]	[2804]	TORQUE (LB-IN) TORQUE (N•M) SPEED (RPM)
	15	<b>146</b>	<b>144</b>	<b>139</b>	<b>135</b>	<b>130</b>	<b>120</b>	<b>105</b>	
Flow (L/min)	[30]	[398]	[831]	[1291]	[1751]	[2211]	[2609]	[2804]	TORQUE (LB-IN) TORQUE (N•M) SPEED (RPM)
	30	<b>291</b>	<b>289</b>	<b>278</b>	<b>274</b>	<b>269</b>	<b>258</b>	<b>242</b>	
Flow (L/min)	[10.6]	[380]	[787]	[1256]	[1733]	[2193]	[2591]	[2795]	TORQUE (LB-IN) TORQUE (N•M) SPEED (RPM)
	40	<b>387</b>	<b>384</b>	<b>374</b>	<b>359</b>	<b>350</b>	<b>335</b>	<b>316</b>	
Flow (L/min)	[13.2]	[354]	[778]	[1194]	[1716]	[2184]	[2582]	[2786]	TORQUE (LB-IN) TORQUE (N•M) SPEED (RPM)
	50	<b>486</b>	<b>483</b>	<b>473</b>	<b>462</b>	<b>450</b>	<b>430</b>	<b>420</b>	
Max cont.	[15.8]	[327]	[778]	[1167]	[1636]	[2158]	[2556]	[2759]	Max cont.
	60	<b>588</b>	<b>584</b>	<b>574</b>	<b>562</b>	<b>550</b>	<b>538</b>	<b>520</b>	
Max int.	[19.8]	[310]	[708]	[1150]	[1592]	[2123]	[2529]	[2742]	Max int.
	75	<b>740</b>	<b>735</b>	<b>720</b>	<b>705</b>	<b>696</b>	<b>676</b>	<b>653</b>	
Max int.	[23.8]	[265]	[663]	[1097]	[1503]	[2087]	[2450]	[2680]	Max int.
	90	<b>850</b>	<b>840</b>	<b>810</b>	<b>787</b>	<b>770</b>	<b>750</b>	<b>747</b>	

YMSE 125

		[7.63 in <sup>3</sup> /rev] 125 cm <sup>3</sup> /rev.				Max cont.	Max int.		
		[507]	[1015]	[1522]	[2030]	[2537]	[3045]	[3262]	
		3.5	7	10.5	14	17.5	21	22.5	
									[PSI]
									MPa
GPM	[3.9]	[486]	[1061]	[1557]	[2167]	[2733]	[3087]	[3317]	TORQUE (LB-IN) TORQUE (N•M) SPEED (RPM)
	L/min	55	120	176	245	309	349	375	
Flow (L/min)	[7.9]	[486]	[1061]	[1548]	[2211]	[2865]	[3317]	[3608]	TORQUE (LB-IN) TORQUE (N•M) SPEED (RPM)
	15	<b>112</b>	<b>110</b>	<b>103</b>	<b>96</b>	<b>93</b>	<b>90</b>	<b>84</b>	
Flow (L/min)	[30]	[486]	[1061]	[1548]	[2211]	[2865]	[3317]	[3608]	TORQUE (LB-IN) TORQUE (N•M) SPEED (RPM)
	30	<b>222</b>	<b>220</b>	<b>217</b>	<b>208</b>	<b>200</b>	<b>199</b>	<b>190</b>	
Flow (L/min)	[10.6]	[486]	[1061]	[1548]	[2211]	[2865]	[3272]	[3608]	TORQUE (LB-IN) TORQUE (N•M) SPEED (RPM)
	40	<b>302</b>	<b>298</b>	<b>292</b>	<b>284</b>	<b>276</b>	<b>268</b>	<b>260</b>	
Flow (L/min)	[13.2]	[442]	[1017]	[1557]	[2193]	[2830]	[3272]	[3591]	TORQUE (LB-IN) TORQUE (N•M) SPEED (RPM)
	50	<b>379</b>	<b>373</b>	<b>368</b>	<b>363</b>	<b>350</b>	<b>339</b>	<b>328</b>	
Max cont.	[15.8]	[398]	[999]	[1512]	[2167]	[2865]	[3255]	[3591]	Max cont.
	60	<b>456</b>	<b>448</b>	<b>443</b>	<b>439</b>	<b>425</b>	<b>406</b>	<b>393</b>	
Max int.	[19.8]	[398]	[973]	[1477]	[2123]	[2777]	[3272]	[3546]	Max int.
	75	<b>570</b>	<b>563</b>	<b>555</b>	<b>546</b>	<b>533</b>	<b>515</b>	<b>503</b>	
Max int.	[23.8]	[354]	[929]	[1433]	[2096]	[2733]	[3228]	[3520]	Max int.
	90	<b>685</b>	<b>676</b>	<b>670</b>	<b>659</b>	<b>644</b>	<b>625</b>	<b>610</b>	

YMS 160

		[9.60 in <sup>3</sup> /rev] 157.2 cm <sup>3</sup> /rev.				Max cont.	Max int.		
		[507]	[1015]	[1522]	[2030]	[2537]	[3045]	[3262]	
		3.5	7	10.5	14	17.5	21	22.5	
									[PSI]
									MPa
GPM	[3.9]	[619]	[1238]	[1813]	[2697]	[3281]	[3803]	[4183]	TORQUE (LB-IN) TORQUE (N•M) SPEED (RPM)
	L/min	70	140	205	305	371	430	473	
Flow (L/min)	[7.9]	[663]	[1327]	[1893]	[2839]	[3361]	[3776]	[4333]	TORQUE (LB-IN) TORQUE (N•M) SPEED (RPM)
	15	<b>91</b>	<b>88</b>	<b>84</b>	<b>78</b>	<b>76</b>	<b>74</b>	<b>58</b>	
Flow (L/min)	[30]	[663]	[1327]	[1893]	[2839]	[3361]	[3776]	[4333]	TORQUE (LB-IN) TORQUE (N•M) SPEED (RPM)
	30	<b>185</b>	<b>182</b>	<b>176</b>	<b>168</b>	<b>164</b>	<b>162</b>	<b>152</b>	
Flow (L/min)	[10.6]	[619]	[1327]	[1901]	[2830]	[3343]	[3759]	[4316]	TORQUE (LB-IN) TORQUE (N•M) SPEED (RPM)
	40	<b>248</b>	<b>244</b>	<b>239</b>	<b>229</b>	<b>224</b>	<b>217</b>	<b>204</b>	
Flow (L/min)	[13.2]	[575]	[1282]	[1901]	[2795]	[3343]	[3759]	[4263]	TORQUE (LB-IN) TORQUE (N•M) SPEED (RPM)
	50	<b>312</b>	<b>308</b>	<b>304</b>	<b>294</b>	<b>288</b>	<b>280</b>	<b>270</b>	
Max cont.	[15.8]	[575]	[1282]	[1893]	[2786]	[3317]	[3750]	[4263]	Max cont.
	60	<b>375</b>	<b>371</b>	<b>365</b>	<b>357</b>	<b>346</b>	<b>336</b>	<b>323</b>	
Max int.	[19.8]	[531]	[1221]	[1840]	[2751]	[3317]	[3714]		Max int.
	75	<b>470</b>	<b>465</b>	<b>458</b>	<b>447</b>	<b>436</b>	<b>426</b>		
Max int.	[23.8]	[495]	[1150]	[1769]	[2724]	[3272]	[3661]		Max int.
	90	<b>564</b>	<b>559</b>	<b>551</b>	<b>541</b>	<b>526</b>	<b>517</b>		

## PERFORMANCE DATA

**YMSE 200**  
[12.21 in<sup>3</sup>/rev] 200 cm<sup>3</sup>/rev. Max cont. Max int.

	[507]	[1015]	[1522]	[2030]	[2537]	[3262]	[PSI]
	3.5	7	10.5	14	17.5	22.5	MPa
GPM	[3.9]	[787]	[1680]	[2609]	[3538]	[4281]	[5377]
	15	<b>73</b>	<b>71</b>	<b>68</b>	<b>64</b>	<b>60</b>	<b>52</b>
L/min	[7.9]	[769]	[1680]	[2600]	[3529]	[4289]	[5306]
	30	<b>87</b>	<b>190</b>	<b>294</b>	<b>399</b>	<b>485</b>	<b>600</b>
Flow (L/min)	[10.6]	[761]	[1663]	[2582]	[3511]	[4272]	[5253]
	40	<b>86</b>	<b>188</b>	<b>292</b>	<b>397</b>	<b>483</b>	<b>594</b>
Flow (L/min)	[13.2]	[708]	[1627]	[2565]	[3493]	[4245]	[5218]
	50	<b>80</b>	<b>184</b>	<b>290</b>	<b>395</b>	<b>480</b>	<b>590</b>
Flow (L/min)	[15.8]	[654]	[1574]	[2530]	[3449]	[4201]	[5147]
	60	<b>74</b>	<b>178</b>	<b>286</b>	<b>390</b>	<b>475</b>	<b>582</b>
Max cont.	[19.8]	[513]	[1415]	[2432]	[3317]	[4068]	[5041]
	75	<b>58</b>	<b>160</b>	<b>275</b>	<b>375</b>	<b>460</b>	<b>570</b>
Max int.	[23.8]	[433]	[1309]	[2299]	[3140]	[3936]	[4908]
	90	<b>49</b>	<b>148</b>	<b>260</b>	<b>355</b>	<b>445</b>	<b>555</b>

TORQUE [LB-IN]  
TORQUE (N•M)  
SPEED (RPM)

Max cont.  
Max int.

**YMSE 250**  
[15.38 in<sup>3</sup>/rev] 252 cm<sup>3</sup>/rev. Max cont. Max int.

	[507]	[1015]	[1522]	[2030]	[2537]	[3262]	[PSI]
	3.5	7	10.5	14	17.5	22.5	MPa
GPM	[3.9]	[1035]	[2034]	[3140]	[3980]	[4900]	[5766]
	15	<b>58</b>	<b>55</b>	<b>52</b>	<b>450</b>	<b>554</b>	<b>652</b>
L/min	[7.9]	[1035]	[1990]	[3095]	[3944]	[4953]	[5811]
	30	<b>117</b>	<b>225</b>	<b>350</b>	<b>446</b>	<b>560</b>	<b>657</b>
Flow (L/min)	[10.6]	[1017]	[1990]	[3078]	[3909]	[4882]	[5749]
	40	<b>115</b>	<b>225</b>	<b>348</b>	<b>442</b>	<b>552</b>	<b>650</b>
Flow (L/min)	[13.2]	[973]	[1946]	[3051]	[3874]	[4829]	[5704]
	50	<b>110</b>	<b>220</b>	<b>345</b>	<b>438</b>	<b>546</b>	<b>645</b>
Flow (L/min)	[15.8]	[929]	[1946]	[3007]	[3847]	[4793]	[5678]
	60	<b>105</b>	<b>220</b>	<b>340</b>	<b>435</b>	<b>542</b>	<b>642</b>
Max cont.	[19.8]	[840]	[1901]	[2989]	[3803]	[4749]	[5642]
	75	<b>95</b>	<b>215</b>	<b>338</b>	<b>430</b>	<b>537</b>	<b>638</b>
Max int.	[23.8]	[796]	[1813]	[2936]	[3714]	[4687]	[5589]
	90	<b>90</b>	<b>205</b>	<b>332</b>	<b>420</b>	<b>530</b>	<b>632</b>

TORQUE [LB-IN]  
TORQUE (N•M)  
SPEED (RPM)

Max cont.  
Max int.

**YMSE 315**  
[19.20 in<sup>3</sup>/rev] 314.5 cm<sup>3</sup>/rev. Max cont. Max int.

	[507]	[1015]	[1522]	[1740]	[2030]	[2682]	[PSI]
	3.5	7	10.5	12	14	18.5	MPa
GPM	[3.9]	[1415]	[2830]	[4112]	[4908]	[5749]	[6615]
	15	<b>48</b>	<b>47</b>	<b>45</b>	<b>43</b>	<b>40</b>	<b>38</b>
L/min	[7.9]	[1459]	[2848]	[4139]	[4953]	[5819]	[6651]
	30	<b>165</b>	<b>322</b>	<b>468</b>	<b>560</b>	<b>658</b>	<b>752</b>
Flow (L/min)	[10.6]	[1415]	[2742]	[4042]	[4829]	[5678]	[6553]
	40	<b>160</b>	<b>310</b>	<b>457</b>	<b>546</b>	<b>642</b>	<b>741</b>
Flow (L/min)	[13.2]	[1371]	[2697]	[3980]	[4758]	[5634]	[6509]
	50	<b>155</b>	<b>305</b>	<b>450</b>	<b>538</b>	<b>637</b>	<b>736</b>
Flow (L/min)	[15.8]	[1344]	[2671]	[3909]	[4705]	[5589]	[6474]
	60	<b>152</b>	<b>302</b>	<b>442</b>	<b>532</b>	<b>632</b>	<b>732</b>
Max cont.	[19.8]	[1282]	[2609]	[3856]	[4643]	[5554]	[6421]
	75	<b>145</b>	<b>295</b>	<b>436</b>	<b>525</b>	<b>628</b>	<b>726</b>
Max int.	[23.8]	[1167]	[2476]	[3803]	[4599]	[5501]	[6394]
	90	<b>132</b>	<b>280</b>	<b>430</b>	<b>520</b>	<b>622</b>	<b>723</b>

TORQUE [LB-IN]  
TORQUE (N•M)  
SPEED (RPM)

Max cont.  
Max int.

**YMSE 375**  
[22.58 in<sup>3</sup>/rev] 370 cm<sup>3</sup>/rev. Max cont. Max int.

	[507]	[1015]	[1305]	[1450]	[1740]	[2030]	[PSI]
	3.5	7	9	10	12	14	MPa
GPM	[3.9]	[1636]	[3202]	[4192]	[4528]	[5200]	[5837]
	15	<b>185</b>	<b>362</b>	<b>474</b>	<b>512</b>	<b>588</b>	<b>660</b>
L/min	[7.9]	[1627]	[3219]	[4201]	[4546]	[5218]	[5846]
	30	<b>184</b>	<b>364</b>	<b>475</b>	<b>514</b>	<b>590</b>	<b>661</b>
Flow (L/min)	[10.6]	[1592]	[3202]	[4183]	[4537]	[5200]	[5828]
	40	<b>180</b>	<b>362</b>	<b>473</b>	<b>513</b>	<b>588</b>	<b>659</b>
Flow (L/min)	[13.2]	[1415]	[3184]	[4174]	[4519]	[5183]	[5819]
	50	<b>160</b>	<b>360</b>	<b>472</b>	<b>511</b>	<b>586</b>	<b>658</b>
Flow (L/min)	[15.8]	[1327]	[3175]	[4166]	[4510]	[5174]	[5811]
	60	<b>150</b>	<b>359</b>	<b>471</b>	<b>510</b>	<b>585</b>	<b>657</b>
Max cont.	[19.8]	1150	[3122]	[4112]	[4457]	[5165]	[5757]
	75	<b>130</b>	<b>353</b>	<b>465</b>	<b>504</b>	<b>584</b>	<b>651</b>
Max int.	[23.8]	[929]	[3095]	[4086]	[4422]	[5130]	[5722]
	90	<b>105</b>	<b>350</b>	<b>462</b>	<b>500</b>	<b>580</b>	<b>647</b>

TORQUE [LB-IN]  
TORQUE (N•M)  
SPEED (RPM)

Max cont.  
Max int.

## END PORT MOUNTING DATA

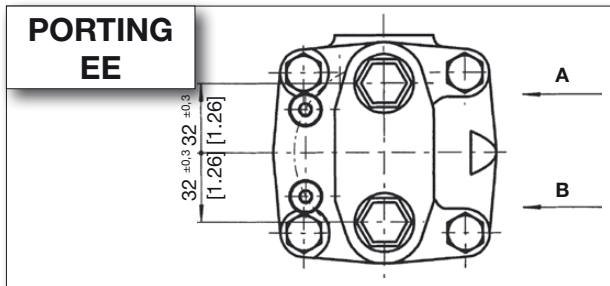
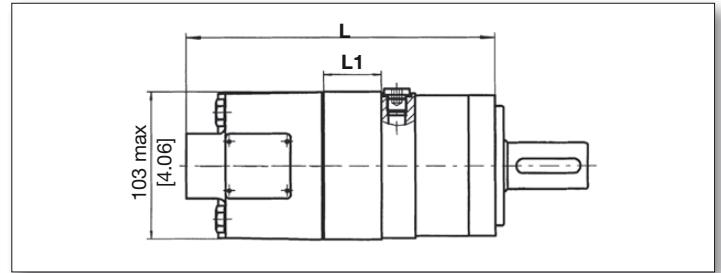
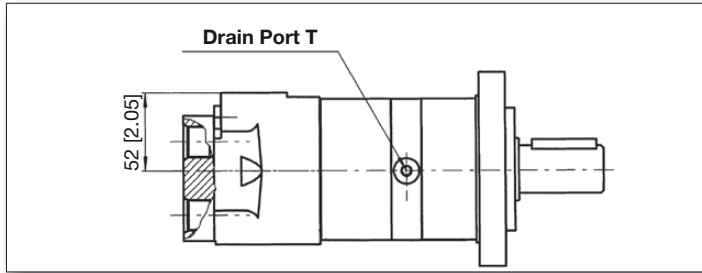

MODEL	[INCHES]		MM	
	L	L1	L	L1
YMSE 80	[6.97]	[0.51]	177	13
YMSE 100	[7.13]	[0.67]	181	17
YMSE 125	[7.32]	[0.87]	186	22
YMSE 160	[7.56]	[1.08]	192	27.5
YMSE 200	[7.91]	[.99]	201	35.1
YMSE 250	[8.31]	[1.85]	211	47
YMSE 315	[8.78]	[2.32]	223	59
YMSE 375	[9.25]	[2.80]	235	71

MODEL	[INCHES]		MM	
	L	L1	L	L1
YMSE 80 WE	[5.49]	[0.51]	139.4	13
YMSE 100 WE	[5.65]	[0.67]	143.4	17
YMSE 125 WE	[5.84]	[0.87]	148.4	22
YMSE 160 WE	[6.10]	[1.08]	154.9	27.5
YMSE 200 WE	[6.43]	[1.38]	163.4	35.1
YMSE 250 WE	[6.83]	[1.85]	173.4	47
YMSE 315 WE	[7.30]	[2.32]	185.4	59
YMSE 375 WE	[7.77]	[2.80]	197.4	71

ORDER CODE	EE-D	DEPTH	EE-M2	DEPTH	EE-S2	DEPTH
PORTS - A and B	G1/2	18 mm	M22x1,5	18 mm	7/8-14 O-ring	18 mm
TANK PORT - T	G1/4	12 mm	M14x1,5	12 mm	7/16-20unf	12 mm

**NOTE: THE THICKNESS OF THE STATOR AND ROTOR IS THE DIMENSION OF L1 PLUS 3MM**

## 180 PORT MOUNTING DATA

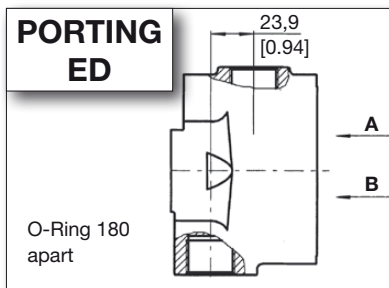
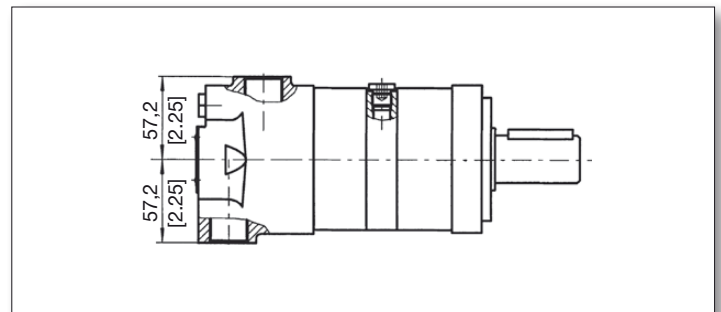
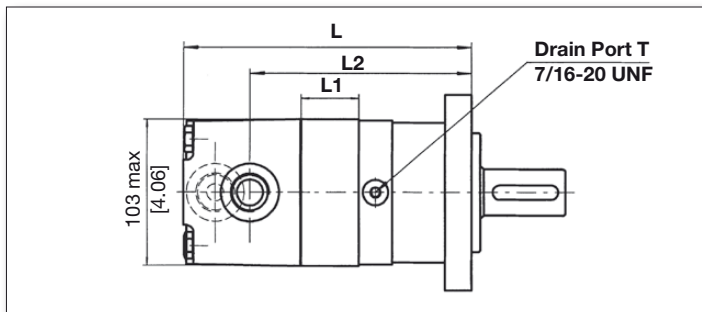

MODEL	[INCHES]			MM		
	L	L1	L2	L	L1	L2
YMSE 80	[6.81]	[.51]	[4.95]	173	13	125.7
YMSE 100	[6.97]	[.67]	[5.11]	177	17	129.7
YMSE 125	[7.17]	[.87]	[5.30]	182	22	134.7
YMSE 160	[7.38]	[1.08]	[5.52]	187.5	27.5	140.2
YMSE 200	[7.68]	[1.38]	[5.81]	195	35.1	147.7
YMSE 250	[8.15]	[1.85]	[6.29]	207	47	159.7
YMSE 315	[8.62]	[2.32]	[6.76]	219	59	171.7
YMSE 375	[9.09]	[2.80]	[7.23]	231	71	183.7

MODEL	[INCHES]			MM		
	L	L1	L2	L	L1	L2
YMSE 80 WE	[5.71]	[.51]	[3.84]	145	13	97.5
YMSE 100 WE	[5.87]	[.67]	[4.00]	149	17	101.5
YMSE 125 WE	[6.02]	[.87]	[4.19]	153	22	106.5
YMSE 160 WE	[6.24]	[1.08]	[4.41]	158.5	27.5	112
YMSE 200 WE	[6.54]	[1.38]	[4.70]	166	35.1	119.5
YMSE 250 WE	[7.05]	[1.85]	[5.18]	179	47	131.5
YMSE 315 WE	[7.52]	[2.32]	[5.65]	191	59	143.5
YMSE 375 WE	[7.99]	[2.80]	[6.12]	203	71	155.5

ORDER CODE	ED-S2	DEPTH
PORTS - A and B	11/16-12 O-RING	18 mm
TANK PORT - T	7/16-20UNF	12 mm

**NOTE: THE THICKNESS OF THE STATOR AND ROTOR IS THE DIMENSION OF L1 PLUS 3MM**



## MOUNTING DATA

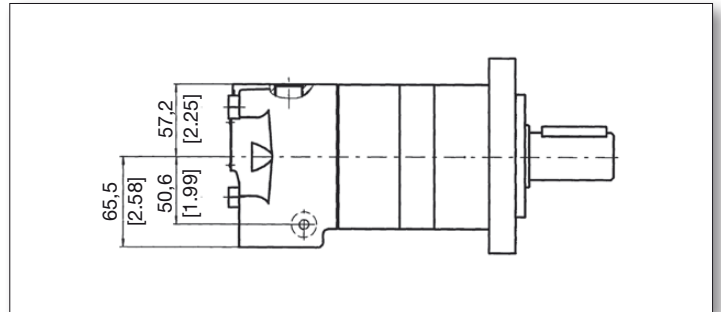
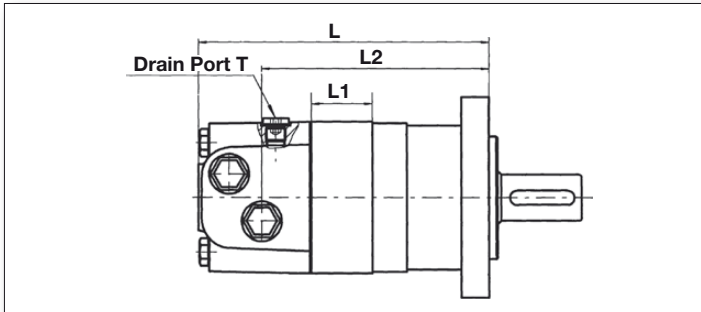

MODEL	[INCHES]			MM		
	L	L1	L2	L	L1	L2
YMSE 80	[6.74]	[.52]	[4.85]	171	13	123.2
YMSE 100	[6.89]	[.67]	[5.01]	175	17	127.2
YMSE 125	[7.09]	[.87]	[5.21]	180	22	132.2
YMSE 160	[7.27]	[1.09]	[5.43]	184.5	27.5	137.7
YMSE 200	[7.60]	[1.39]	[5.72]	193	35.1	145.2
YMSE 250	[8.07]	[1.85]	[6.19]	205	47	157.2
YMSE 315	[8.55]	[2.33]	[6.67]	217	59	169.2
YMSE 375	[9.02]	[2.80]	[7.14]	229	71	181.2

MODEL	[INCHES]			MM		
	L	L1	L2	L	L1	L2
YMSE 80 WE	[5.63]	[.51]	[3.74]	143	13	95
YMSE 100 WE	[5.79]	[.67]	[3.90]	147	17	99
YMSE 125 WE	[5.98]	[.87]	[4.09]	152	22	104
YMSE 160 WE	[6.20]	[1.08]	[4.31]	157.5	27.5	109.5
YMSE 200 WE	[6.50]	[1.38]	[4.61]	165	35.1	117
YMSE 250 WE	[6.97]	[1.85]	[5.08]	177	47	129
YMSE 315 WE	[7.44]	[2.32]	[5.55]	189	59	141
YMSE 375 WE	[7.91]	[2.80]	[6.02]	201	71	153

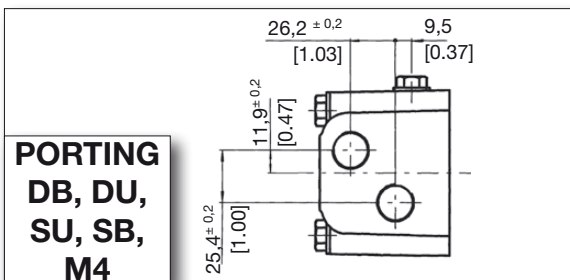

**NOTE: THE THICKNESS OF THE STATOR AND ROTOR IS THE DIMENSION OF L1 PLUS 3MM**

ORDER CODE	DB depth	DU depth	SU depth	SB depth	M4 depth
P(A, B)	G1/2 (18)	G1/2 (18)	7/8-14 O-ring (18)	7/8-14 O-ring (18)	M22 x 1,5 (18)
T	G1/4 (12)	7/16-20 UNF (12)	7/16-20 UNF (12)	G1/4 (12)	M14 x 1,5 (12)

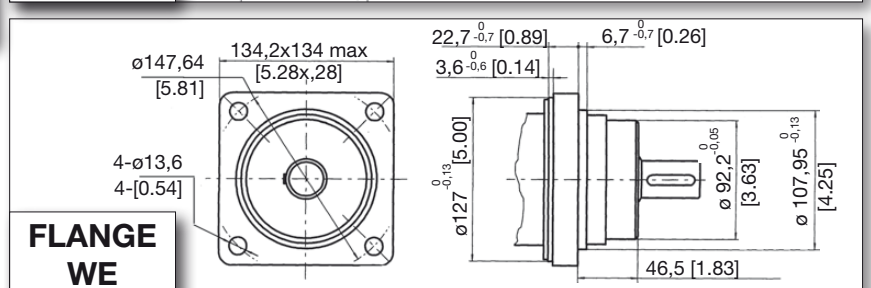
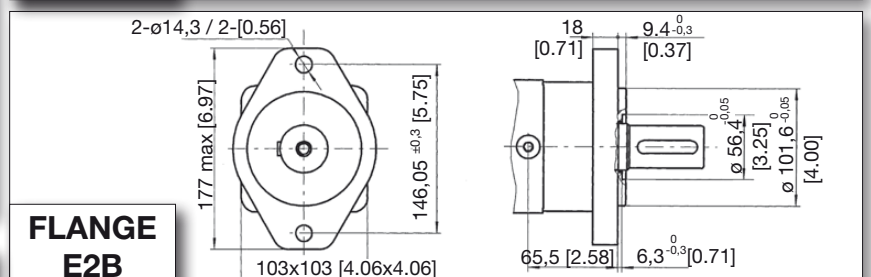
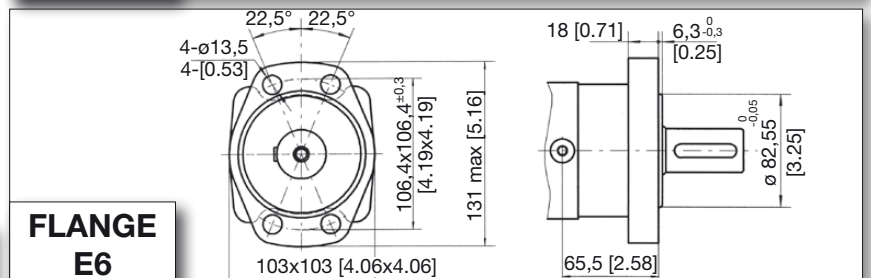
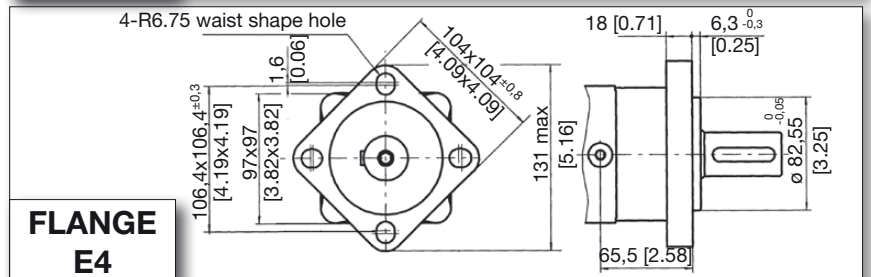
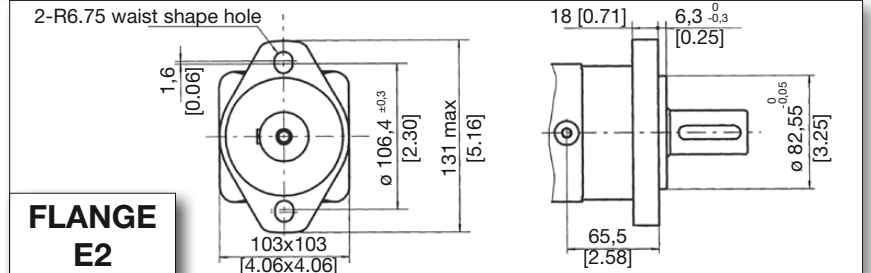

## MOUNTING DATA

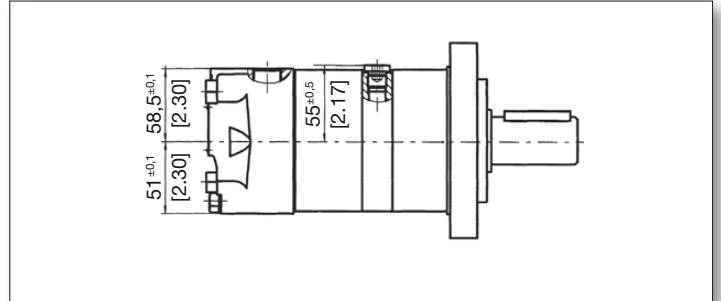
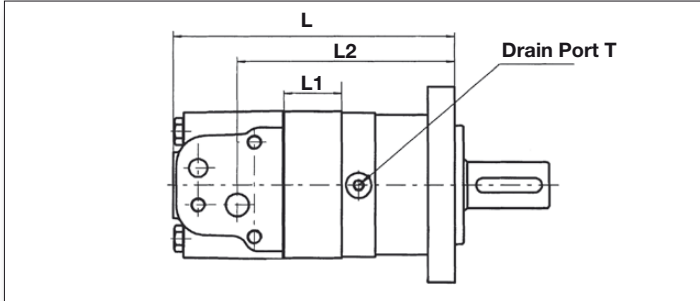

MODEL	[INCHES]			MM		
	L	L1	L2	L	L1	L2
YMSE 80	[6.57]	[.51]	[4.79]	167	13	121.7
YMSE 100	[6.73]	[.67]	[4.95]	171	17	125.7
YMSE 125	[6.93]	[.87]	[5.15]	176	22	130.7
YMSE 160	[7.15]	[1.08]	[5.36]	181.5	27.5	136.2
YMSE 200	[7.44]	[.99]	[5.66]	189	25.1	143.7
YMSE 250	[7.91]	[1.85]	[6.13]	201	47	155.7
YMSE 315	[8.39]	[2.32]	[6.60]	213	59	167.7
YMSE 375	[8.86]	[2.80]	[7.07]	225	71	179.7

MODEL	[INCHES]			MM		
	L	L1	L2	L	L1	L2
YMSE 80 WE	[5.47]	[.51]	[3.68]	139	13	93.5
YMSE 100 WE	[5.63]	[.67]	[3.84]	143	17	97.5
YMSE 125 WE	[5.83]	[.87]	[4.04]	148	22	102.5
YMSE 160 WE	[6.04]	[1.08]	[4.25]	153.5	27.5	108
YMSE 200 WE	[6.34]	[1.38]	[4.55]	161	35.1	115.5
YMSE 250 WE	[6.81]	[1.85]	[5.02]	173	47	127.5
YMSE 315 WE	[7.28]	[2.32]	[5.49]	185	59	139.5
YMSE 375 WE	[7.76]	[2.80]	[5.96]	197	71	151.5

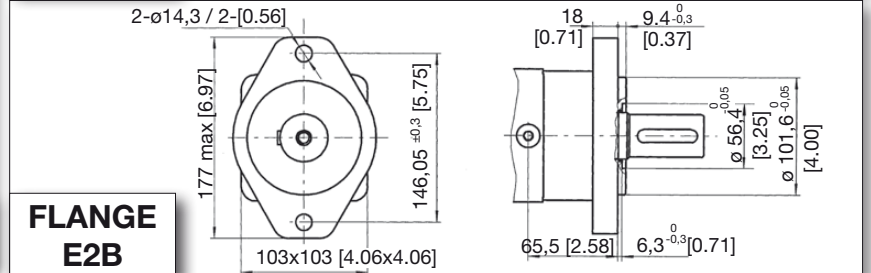
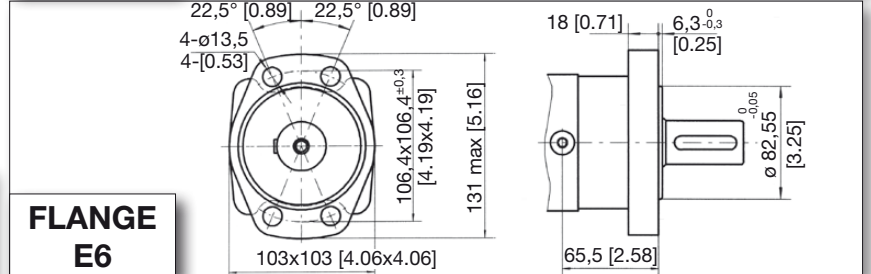
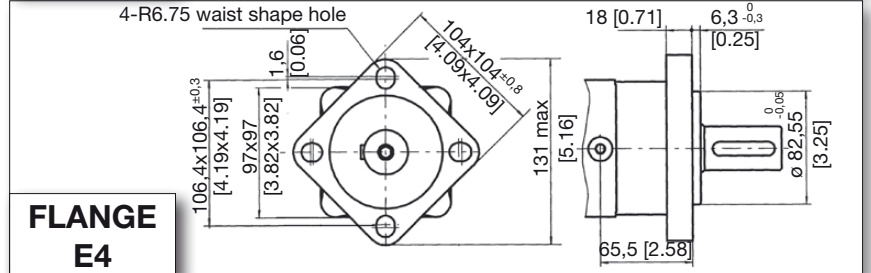
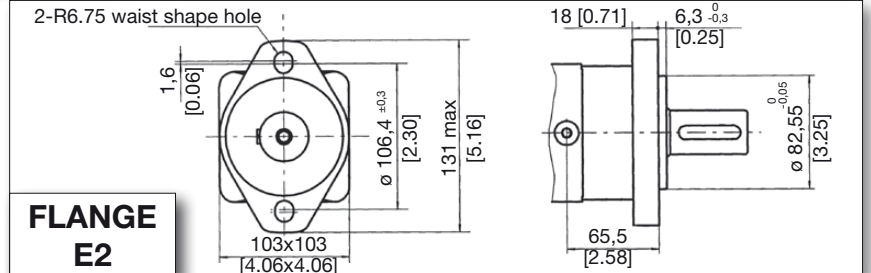
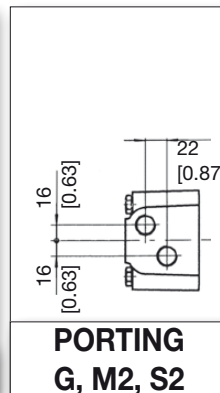
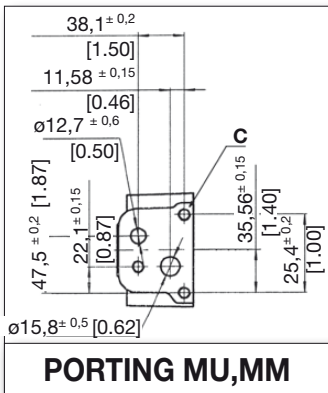

ORDER CODE	MU	MM	G depth	M2 depth	S2 depth
P(A, B)	ø12.7 ø15.8	ø12.7 ø15.8	G 1/2 (18)	M22 x 1.5 (18)	7/8-14 O-ring
T	7/16-20 UNF (12)	G 1/4 (12)	G 1/4 (12)	M14 x 1.5 (12)	7/16-20 UNF
C	3x3/8-16 UNC	3 x M10	-	-	-

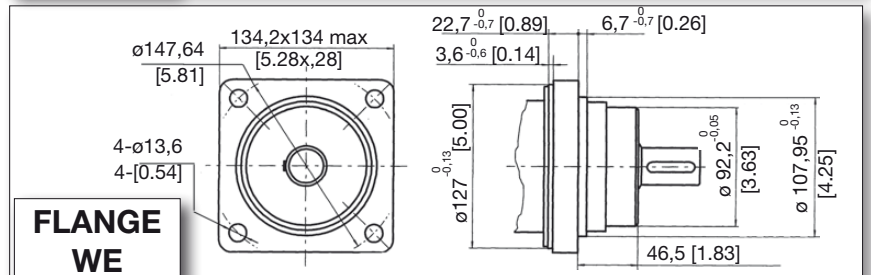

## MOTOR SHAFT EXTENSIONS

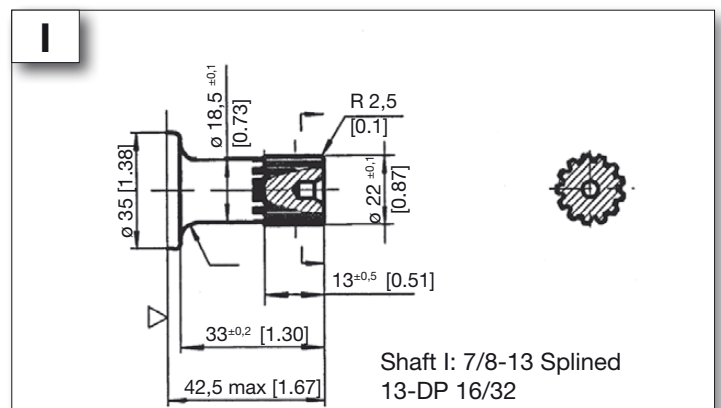
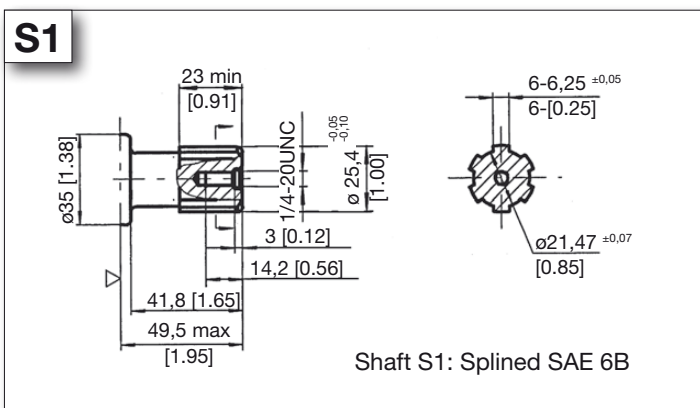
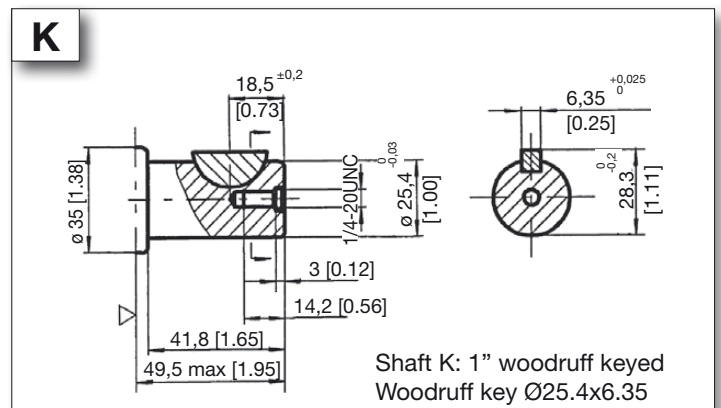
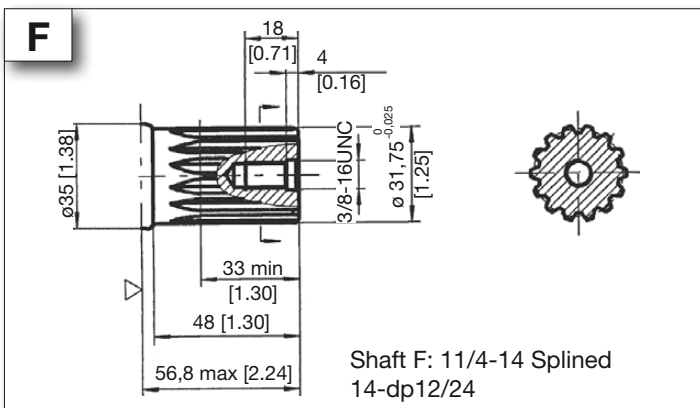
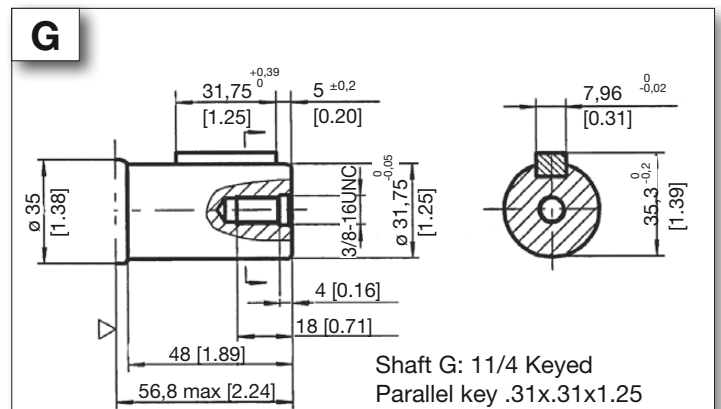
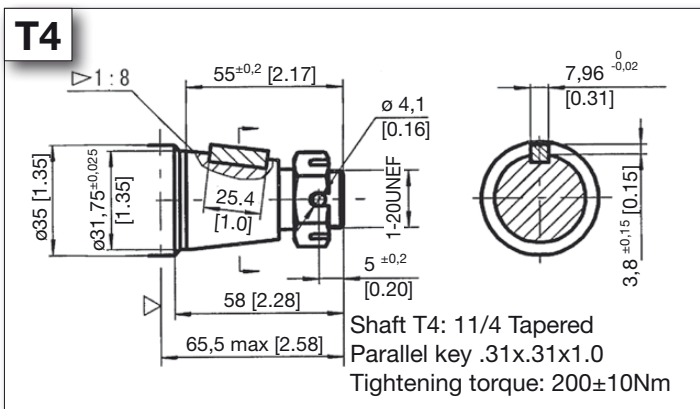
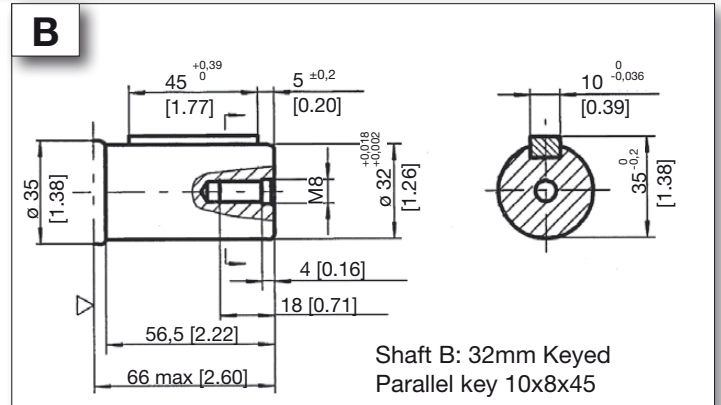
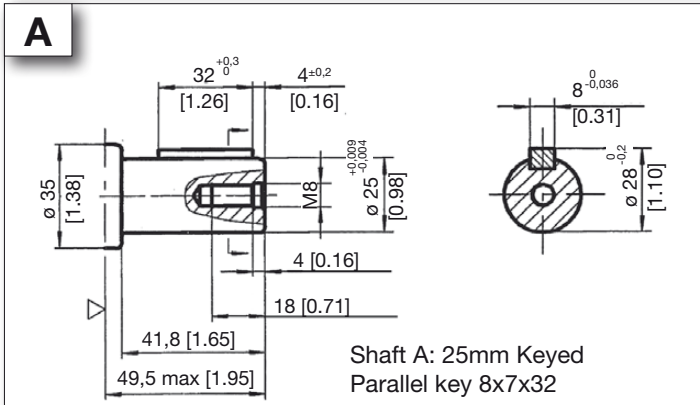

## ADDITIONAL DATA

### PERMISSIBLE SHAFT SEAL PRESSURE

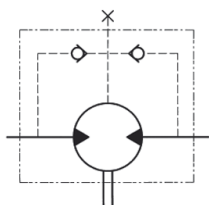

Note: Curve 1 for standard shaft seal  
Curve 2 for high pressure shaft seal

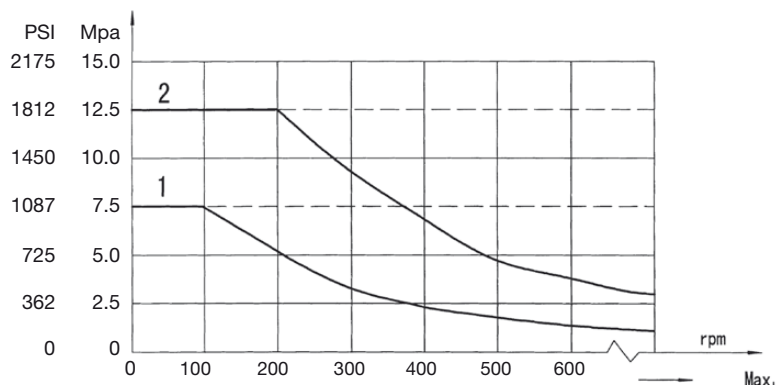

IN APPLICATIONS WITHOUT A DRAIN LINE, THE PRESSURE EXERTED ON THE SHAFT SEAL WILL EXCEED THE PRESSURE IN THE RETURN LINE. IN APPLICATIONS USING A DRAIN LINE, THE PRESSURE ON THE OUTPUT SHAFT SEAL CAN EQUAL THE PRESSURE IN DRAIN LINE.

### DIRECTION OF SHAFT ROTATION

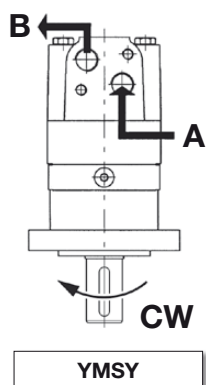
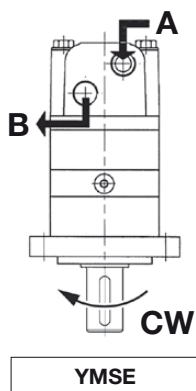

### AXIAL AND RADIAL FORCES

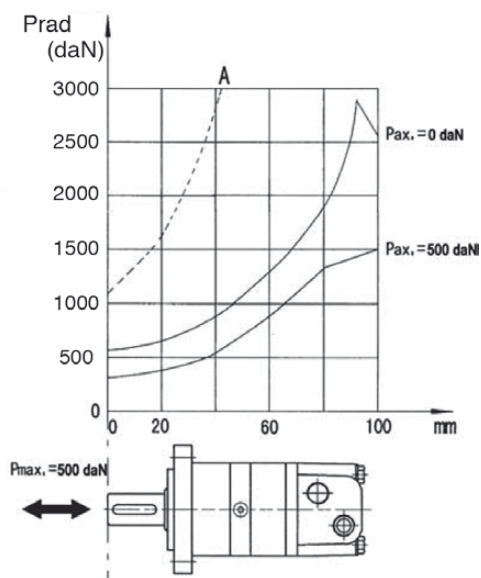

When viewing the motor from the output shaft end, port A is defined to be on the right and port B is defined to be on the left side. Standard rotation motors rotate CW when port A is pressurized. The motors are bi-directional and CCW rotation occurs when port B is pressurized.

Reverse rotation motors can special ordered which will operate with opposite rotation outlined above.

## ORDERING INFORMATION

	<b>1</b>	<b>2</b>	<b>3</b>	<b>4</b>	<b>5</b>	<b>6</b>	<b>7</b>
<b>YMSE</b>							

1	2	3	4	5	6	7	
DISP.	FLANGE	OUTPUT SHAFT	PORT AND DRAIN PORT	ROTATION DIRECTION		PAINT	SPECIAL OPTIONS
80	E2 SAE 2-Bolt pilot 3.25x.25	A Shaft: 25mm Keyed parallel Key 8x7x32	MU 1/2",5/8"Crosshole Manifold 3x3/8- 16UNC, 7/16-20UNF	NONE	STANDARD	00 NO PAINT	NONE STANDARD
100	E4 4-Bolt flange pilot 3.25x.25	B Shaft: 32mm Keyed parallel Key 10x8x45	MM 1/2",5/8"Crosshole Manifold 3xM10, G1/4	R	OPPOSITE		FR FREE RUNNING
125	E6 Magneto-flange, pilot 3.25x.25	K Shaft: 1"Woodruff Key key 1.0x.25	EE-D G1/2,G1/4			B BLACK	
160	E2B SAE 2-BOLT pilot4.00x .37	G Shaft: 11/4 Ke- yed parallel Key .31x.31x1.25	EE-M2 M22X1.5, M14X1.5				LSV LOW SPEED VALVE
200	WE 4-Ø13.5 Wheel-flange, pilot Ø125x8	F Shaft: 11/4-14 Spli- ned 14-DP12/24	EE-S2 7/8-14UNF O-ring 7/16-20 UNF				CRS CORROSION RESISTANT SHAFT
250		T4 Shaft:11/4 Tapered parallel key .31x.31x1.0	ED 1-1/16-12UNF O-ring,7/16-20 UNF				HPS HIGH PRESSU- RE SEAL
315		S1 Shaft: SAE 6B Splined	DB G1/2,G1/4				HTS HIGH TEMP SEAL
375		I Shaft: 7/8-13 Splined 13-DP16/32	DU G1/2,7/16-20UNF				
			SB 7/8-14UNF O-ring,G1/4				
			SU 7/8-14UNF O-ring 7/16-20UNF				
			M4 M22X1.5,M14X1.5				
			G G1/2,G1/4				
			M2 M22X1.5,M14X1.5				
			S2 7/8-14UNF O-ring, 7/16-20UNF				

**ORDERING CODE:**

All options have been determined with letters, numbers or combinations. All boxes must be filled with proper codes. If specification is not in the table, please contact us with your requirements.



# YMSS

The **YMSS** series motor incorporates the advanced **GEROLOR** gear set which reduces internal friction to a minimum. A “**DISC VALVE**” distribution system which is internally balanced to reduce friction, leakage and permits better speed control producing higher efficiency, smoother rotation, higher speed and pressure.

This series has many sizes and options to make it very flexible for many applications.

## SPECIFICATIONS

Distribution Type	Model	Displacement		Max. Operating Pressure		Speed Range Continuous	Max. Output Power	
		[in <sup>3</sup> ./rev]	[4.88 ~ 22.88]	[PSI]	[3263]		[HP]	[27]
Disc Distribution	YMSS	cm <sup>3</sup> /rev.	80 ~ 375	MPa	22.5	30 ~ 800	Kw	20

## QUICK REFERENCE GUIDE

### YMSS SERIES QUICK REFERENCE:

Displacements				
[in <sup>3</sup> /rev]	cm <sup>3</sup> /rev.			
[4.92]	80.6	FLOW UP TO	90 LPM	[23.78 GPM]
[6.15]	100.8	PRESSURE UP TO	22.5 MPA	[3262 PSI]
[7.63]	125	TORQUE UP TO	751 NM	[3944 LB. IN.]
[9.59]	157.2	SPEED UP TO	446 RPM	
[12.2]	200			
[15.38]	252			
[19.19]	314.5			
[22.57]	370			

**Shaft Seals:** Standard high pressure shaft seals permit applications in series or without drain line when required

**Low Speed Valving:** These motors are manufactured following strict procedures to reduce tolerances between all components to permit lower speed, higher efficiency and smoother rotation at very low speeds. These motors are not for high speed or low pressure applications.

**Free Running:** Motors with this option have increased clearances in the rotor set. This allows improved mechanical efficiency, longer life and better performance for high-speed / high-flow applications, winch or similar applications where the motor is cross-ported to allow manual free turning also may benefit from this option to allow smoother easier free turning of the motor. Last, applications which have many reversals or high pressure spikes can also benefit since the pressure spikes will be reduced by relieving (cross-porting) such spikes internally in the motor. The trade off of these benefits is a slight reduction in volumetric efficiency, particularly at high pressure conditions.

**Special Motors:** These motors have special options like nickel plated shafts or housings for applications in corrosive environments.

### APPLICATION GUIDELINES:

For optimum results the following working conditions are recommended:

- \* Oil temperature should be between 20° - 60° C [68° - 180° F]
- \* Oil filter of 10 - 20 micron
- \* Oil viscosity 42 - 74 mm<sup>2</sup>/s CSA at 40° C
- \* For longer life we suggest the motor at start up, run for a shorter period of time (one hour) at no more than 30% of rated speed and pressure.



## SPECIFICATION DATA

For individual motor performance chart consult equivalent YMS series data.

DISTRIBUTION TYPE			YMSS 80	YMSS 100	YMSS 125	YMSS 160	YMSS 200	YMSS 250	YMSS 315	YMSS 375
GEOMETRIC DISPLACEMENT	[in <sup>3</sup> ./rev.]		[4.92]	[6.16]	[7.63]	[9.60]	[12.21]	[15.38]	[19.20]	[22.58]
	cm <sup>3</sup> /rev.		80.6	100.8	125	157.2	200	252	314.5	370
MAX. SPEED RPM	CONT.		800	748	600	470	375	300	240	200
	INT.		988	900	720	560	450	360	280	240
MAX. TORQUE [LB. IN.] N*M	CONT.	[LB. IN.]	[1680]	[2123]	[2742]	[2795]	[3538]	[3980]	[4953]	[4740]
		N*M	<b>190</b>	<b>240</b>	<b>310</b>	<b>316</b>	<b>400</b>	<b>450</b>	<b>560</b>	<b>536</b>
	INT.	[LB. IN.]	[2123]	[2653]	[3272]	[3803]	[4121]	[4776]	[5819]	[5704]
		N*M	<b>240</b>	<b>300</b>	<b>370</b>	<b>430</b>	<b>466</b>	<b>540</b>	<b>658</b>	<b>645</b>
	PEAK	[LB. IN.]	[2299]	[2830]	[3538]	[4174]	[5749]	[6102]	[6545]	[6642]
		N*M	<b>260</b>	<b>320</b>	<b>400</b>	<b>472</b>	<b>650</b>	<b>690</b>	<b>740</b>	<b>751</b>
MAX. OUTPUT [HP] KW	CONT.	[HP]	[21]	[25]	[26]	[21]	[21]	[19]	[19]	[16]
		KW	<b>15.9</b>	<b>18.8</b>	<b>19.5</b>	<b>15.6</b>	<b>15.7</b>	<b>14.1</b>	<b>14.1</b>	<b>11.8</b>
	INT.	[HP]	[27]	[31]	[31]	[29]	[25]	[23]	[25]	[23]
		KW	<b>20.1</b>	<b>23.5</b>	<b>23.2</b>	<b>21.2</b>	<b>18.3</b>	<b>17.0</b>	<b>18.9</b>	<b>17</b>
MAX. PRESSURE DROP [PSI] MP <sub>A</sub>	CONT.	[PSI]	[2538]	[2538]	[2538]	[2175]	[2030]	[1813]	[1740]	[1450]
		MP <sub>A</sub>	<b>17.5</b>	<b>17.5</b>	<b>17.5</b>	<b>15</b>	<b>14</b>	<b>12.5</b>	<b>12</b>	<b>10</b>
	INT.	[PSI]	[3045]	[3045]	[3045]	[3045]	[2320]	[2320]	[2030]	[1740]
		MP <sub>A</sub>	<b>21</b>	<b>21</b>	<b>21</b>	<b>21</b>	<b>16</b>	<b>16</b>	<b>14</b>	<b>12</b>
	PEAK	[PSI]	[3263]	[3263]	[3263]	[3263]	[3263]	[2900]	[2683]	[2030]
		MP <sub>A</sub>	<b>22.5</b>	<b>22.5</b>	<b>22.5</b>	<b>22.5</b>	<b>22.5</b>	<b>20</b>	<b>18.5</b>	<b>14</b>
MAX. FLOW [GPM] L/MIN	CONT.	[GPM]	[17.1]	[19.8]	[19.8]	[19.8]	[19.8]	[19.8]	[19.8]	[19.8]
		L/MIN	<b>65</b>	<b>75</b>	<b>75</b>	<b>75</b>	<b>75</b>	<b>75</b>	<b>75</b>	<b>75</b>
	INT.	[GPM]	[21.1]	[23.7]	[23.7]	[23.7]	[23.7]	[23.7]	[23.7]	[23.7]
		L/MIN	<b>80</b>	<b>90</b>	<b>90</b>	<b>90</b>	<b>90</b>	<b>90</b>	<b>90</b>	<b>90</b>
MAX. INLET PRESSURE [PSI] MP <sub>A</sub>	CONT.	[PSI]	[3625]	[3625]	[3625]	[3625]	[3625]	[3625]	[3625]	[3625]
		MP <sub>A</sub>	<b>25</b>	<b>25</b>	<b>25</b>	<b>25</b>	<b>25</b>	<b>25</b>	<b>25</b>	<b>25</b>
	INT.	[PSI]	[4350]	[4350]	[4350]	[4350]	[4350]	[4350]	[4350]	[4350]
		MP <sub>A</sub>	<b>30</b>	<b>30</b>	<b>30</b>	<b>30</b>	<b>30</b>	<b>30</b>	<b>30</b>	<b>30</b>
WEIGHT [LB] KG	[LB]	[22]	[22]	[23]	[24]	[24]	[26]	[27]	[28]	
	KG	<b>9.8</b>	<b>10</b>	<b>10.3</b>	<b>10.7</b>	<b>11.1</b>	<b>11.6</b>	<b>12.3</b>	<b>12.6</b>	

## PERFORMANCE DATA

YMSS 80

		[4.92 in <sup>3</sup> /rev] 80.6 cm <sup>3</sup> /rev.				Max cont.	Max int.	[PSI] MPa	
		[507]	[1015]	[1522]	[2030]	[2537]	[3045]		[3262]
		3.5	7	10.5	14	17.5	21	22.5	
GPM L/min	[3.9]	[310]	[707]	[1061]	[1397]	[1724]	[2078]	[2202]	TORQUE (LB-IN) TORQUE (N•M) SPEED (RPM)
	15	<b>180</b>	<b>174</b>	<b>168</b>	<b>164</b>	<b>158</b>	<b>151</b>	<b>143</b>	
Flow (L/min)	[7.9]	[310]	[707]	[1061]	[1397]	[1724]	[2122]	[2299]	TORQUE (LB-IN) TORQUE (N•M) SPEED (RPM)
	30	<b>362</b>	<b>352</b>	<b>346</b>	<b>338</b>	<b>330</b>	<b>322</b>	<b>310</b>	
Flow (L/min)	[10.6]	[310]	[699]	[1052]	[1371]	[1707]	[2070]	[2211]	TORQUE (LB-IN) TORQUE (N•M) SPEED (RPM)
	40	<b>482</b>	<b>473</b>	<b>464</b>	<b>453</b>	<b>444</b>	<b>434</b>	<b>415</b>	
Flow (L/min)	[13.2]	[265]	[681]	[1035]	[1353]	[1698]	[2052]	[2193]	TORQUE (LB-IN) TORQUE (N•M) SPEED (RPM)
	50	<b>602</b>	<b>594</b>	<b>587</b>	<b>569</b>	<b>560</b>	<b>551</b>	<b>522</b>	
Max cont.	[15.8]	[248]	[681]	[1035]	[1353]	[1698]	[2052]	[2184]	TORQUE (LB-IN) TORQUE (N•M) SPEED (RPM)
	60	<b>724</b>	<b>713</b>	<b>707</b>	<b>683</b>	<b>673</b>	<b>664</b>	<b>629</b>	
Max cont.	[19.8]	[221]	[663]	[1008]	[1344]	[1680]	[2034]	[2167]	TORQUE (LB-IN) TORQUE (N•M) SPEED (RPM)
	75	<b>840</b>	<b>832</b>	<b>817</b>	<b>796</b>	<b>786</b>	<b>777</b>	<b>737</b>	
Max int.	[23.8]	[212]	[646]	[973]	[1327]	[1636]	[1990]	[2123]	TORQUE (LB-IN) TORQUE (N•M) SPEED (RPM)
	90	<b>900</b>	<b>893</b>	<b>872</b>	<b>853</b>	<b>843</b>	<b>834</b>	<b>792</b>	

YMSS 100

		[6.16 in <sup>3</sup> /rev] 100.8 cm <sup>3</sup> /rev.				Max cont.	Max int.	[PSI] MPa	
		[507]	[1015]	[1522]	[2030]	[2537]	[3045]		[3262]
		3.5	7	10.5	14	17.5	21	22.5	
GPM L/min	[3.9]	[425]	[840]	[1327]	[1769]	[2211]	[2556]	[2742]	TORQUE (LB-IN) TORQUE (N•M) SPEED (RPM)
	15	<b>146</b>	<b>144</b>	<b>139</b>	<b>135</b>	<b>130</b>	<b>120</b>	<b>105</b>	
Flow (L/min)	[7.9]	[398]	[831]	[1291]	[1751]	[2211]	[2609]	[2804]	TORQUE (LB-IN) TORQUE (N•M) SPEED (RPM)
	30	<b>291</b>	<b>289</b>	<b>278</b>	<b>274</b>	<b>269</b>	<b>258</b>	<b>242</b>	
Flow (L/min)	[10.6]	[380]	[787]	[1256]	[1733]	[2193]	[2591]	[2795]	TORQUE (LB-IN) TORQUE (N•M) SPEED (RPM)
	40	<b>387</b>	<b>384</b>	<b>374</b>	<b>359</b>	<b>350</b>	<b>335</b>	<b>316</b>	
Flow (L/min)	[13.2]	[354]	[778]	[1194]	[1716]	[2184]	[2582]	[2786]	TORQUE (LB-IN) TORQUE (N•M) SPEED (RPM)
	50	<b>486</b>	<b>483</b>	<b>473</b>	<b>462</b>	<b>450</b>	<b>430</b>	<b>420</b>	
Max cont.	[15.8]	[327]	[778]	[1167]	[1636]	[2158]	[2556]	[2759]	TORQUE (LB-IN) TORQUE (N•M) SPEED (RPM)
	60	<b>588</b>	<b>584</b>	<b>574</b>	<b>562</b>	<b>550</b>	<b>538</b>	<b>520</b>	
Max cont.	[19.8]	[310]	[708]	[1150]	[1592]	[2123]	[2529]	[2742]	TORQUE (LB-IN) TORQUE (N•M) SPEED (RPM)
	75	<b>740</b>	<b>735</b>	<b>720</b>	<b>705</b>	<b>696</b>	<b>676</b>	<b>653</b>	
Max int.	[23.8]	[265]	[663]	[1097]	[1503]	[2087]	[2450]	[2680]	TORQUE (LB-IN) TORQUE (N•M) SPEED (RPM)
	90	<b>850</b>	<b>840</b>	<b>810</b>	<b>787</b>	<b>770</b>	<b>750</b>	<b>747</b>	

YMSS 125

		[7.63 in <sup>3</sup> /rev] 125 cm <sup>3</sup> /rev.				Max cont.	Max int.	[PSI] MPa	
		[507]	[1015]	[1522]	[2030]	[2537]	[3045]		[3262]
		3.5	7	10.5	14	17.5	21	22.5	
GPM L/min	[3.9]	[486]	[1061]	[1557]	[2167]	[2733]	[3087]	[3317]	TORQUE (LB-IN) TORQUE (N•M) SPEED (RPM)
	15	<b>112</b>	<b>110</b>	<b>103</b>	<b>96</b>	<b>93</b>	<b>90</b>	<b>84</b>	
Flow (L/min)	[7.9]	[486]	[1061]	[1548]	[2211]	[2865]	[3317]	[3608]	TORQUE (LB-IN) TORQUE (N•M) SPEED (RPM)
	30	<b>222</b>	<b>220</b>	<b>217</b>	<b>208</b>	<b>200</b>	<b>199</b>	<b>190</b>	
Flow (L/min)	[10.6]	[486]	[1061]	[1548]	[2211]	[2865]	[3272]	[3608]	TORQUE (LB-IN) TORQUE (N•M) SPEED (RPM)
	40	<b>302</b>	<b>298</b>	<b>292</b>	<b>284</b>	<b>276</b>	<b>268</b>	<b>260</b>	
Flow (L/min)	[13.2]	[442]	[1017]	[1557]	[2193]	[2830]	[3272]	[3591]	TORQUE (LB-IN) TORQUE (N•M) SPEED (RPM)
	50	<b>379</b>	<b>373</b>	<b>368</b>	<b>363</b>	<b>350</b>	<b>339</b>	<b>328</b>	
Max cont.	[15.8]	[398]	[999]	[1512]	[2167]	[2865]	[3255]	[3591]	TORQUE (LB-IN) TORQUE (N•M) SPEED (RPM)
	60	<b>456</b>	<b>448</b>	<b>443</b>	<b>439</b>	<b>425</b>	<b>406</b>	<b>393</b>	
Max cont.	[19.8]	[398]	[973]	[1477]	[2123]	[2777]	[3272]	[3546]	TORQUE (LB-IN) TORQUE (N•M) SPEED (RPM)
	75	<b>570</b>	<b>563</b>	<b>555</b>	<b>546</b>	<b>533</b>	<b>515</b>	<b>503</b>	
Max int.	[23.8]	[354]	[929]	[1433]	[2096]	[2733]	[3228]	[3520]	TORQUE (LB-IN) TORQUE (N•M) SPEED (RPM)
	90	<b>685</b>	<b>676</b>	<b>670</b>	<b>659</b>	<b>644</b>	<b>625</b>	<b>610</b>	

YMSS 160

		[9.60 in <sup>3</sup> /rev] 157.2 cm <sup>3</sup> /rev.				Max cont.	Max int.	[PSI] MPa	
		[507]	[1015]	[1522]	[2030]	[2537]	[3045]		[3262]
		3.5	7	10.5	14	17.5	21	22.5	
GPM L/min	[3.9]	[619]	[1238]	[1813]	[2697]	[3281]	[3803]	[4183]	TORQUE (LB-IN) TORQUE (N•M) SPEED (RPM)
	15	<b>91</b>	<b>88</b>	<b>84</b>	<b>78</b>	<b>76</b>	<b>74</b>	<b>58</b>	
Flow (L/min)	[7.9]	[663]	[1327]	[1893]	[2839]	[3361]	[3776]	[4333]	TORQUE (LB-IN) TORQUE (N•M) SPEED (RPM)
	30	<b>185</b>	<b>182</b>	<b>176</b>	<b>168</b>	<b>164</b>	<b>162</b>	<b>152</b>	
Flow (L/min)	[10.6]	[619]	[1327]	[1901]	[2830]	[3343]	[3759]	[4316]	TORQUE (LB-IN) TORQUE (N•M) SPEED (RPM)
	40	<b>248</b>	<b>244</b>	<b>239</b>	<b>229</b>	<b>224</b>	<b>217</b>	<b>204</b>	
Flow (L/min)	[13.2]	[575]	[1282]	[1901]	[2795]	[3343]	[3759]	[4263]	TORQUE (LB-IN) TORQUE (N•M) SPEED (RPM)
	50	<b>312</b>	<b>308</b>	<b>304</b>	<b>294</b>	<b>288</b>	<b>280</b>	<b>270</b>	
Max cont.	[15.8]	[575]	[1282]	[1893]	[2786]	[3317]	[3750]	[4263]	TORQUE (LB-IN) TORQUE (N•M) SPEED (RPM)
	60	<b>375</b>	<b>371</b>	<b>365</b>	<b>357</b>	<b>346</b>	<b>336</b>	<b>323</b>	
Max cont.	[19.8]	[531]	[1221]	[1840]	[2751]	[3317]	[3714]		TORQUE (LB-IN) TORQUE (N•M) SPEED (RPM)
	75	<b>470</b>	<b>465</b>	<b>458</b>	<b>447</b>	<b>436</b>	<b>426</b>		
Max int.	[23.8]	[495]	[1150]	[1769]	[2724]	[3272]	[3661]		TORQUE (LB-IN) TORQUE (N•M) SPEED (RPM)
	90	<b>564</b>	<b>559</b>	<b>551</b>	<b>541</b>	<b>526</b>	<b>517</b>		

## PERFORMANCE DATA

### YMSS 200

		[12.21 in <sup>3</sup> /rev] 200 cm <sup>3</sup> /rev.					Max cont.	Max int.		
		[507]	[1015]	[1522]	[2030]	[2537]	[3262]	[PSI]		
		3.5	7	10.5	14	17.5	22.5	MPa		
GPM	[3.9]	[787]	[1680]	[2609]	[3538]	[4281]	[5377]			
	15	<b>73</b>	<b>71</b>	<b>68</b>	<b>64</b>	<b>60</b>	<b>52</b>			
	[7.9]	[769]	[1680]	[2600]	[3529]	[4289]	[5306]	TORQUE [LB-IN] TORQUE (N•M) SPEED (RPM)		
	30	<b>148</b>	<b>146</b>	<b>143</b>	<b>140</b>	<b>135</b>	<b>127</b>			
Flow (L/min)	[10.6]	[761]	[1663]	[2582]	[3511]	[4272]	[5253]			
	40	<b>193</b>	<b>191</b>	<b>189</b>	<b>186</b>	<b>181</b>	<b>172</b>			
	[13.2]	[708]	[1627]	[2565]	[3493]	[4245]	[5218]			
	50	<b>247</b>	<b>245</b>	<b>243</b>	<b>240</b>	<b>235</b>	<b>226</b>			
Max cont	[15.8]	[654]	[1574]	[2530]	[3449]	[4201]	[5147]	Max cont.		
	60	<b>298</b>	<b>295</b>	<b>293</b>	<b>290</b>	<b>284</b>	<b>273</b>			
Max int.	[19.8]	[513]	[1415]	[2432]	[3317]	[4068]	[5041]	Max int.		
	75	<b>372</b>	<b>369</b>	<b>365</b>	<b>362</b>	<b>358</b>	<b>346</b>			
	[23.8]	[433]	[1309]	[2299]	[3140]	[3936]	[4908]			
	90	<b>440</b>	<b>435</b>	<b>430</b>	<b>422</b>	<b>411</b>	<b>401</b>			

### YMSS 250

		[15.38 in <sup>3</sup> /rev] 252 cm <sup>3</sup> /rev.					Max cont.	Max int.		
		[507]	[1015]	[1522]	[2030]	[2537]	[3262]	[PSI]		
		3.5	7	10.5	14	17.5	22.5	MPa		
GPM	[3.9]	[1035]	[2034]	[3140]	[3980]	[4900]	[5766]			
	15	<b>58</b>	<b>55</b>	<b>52</b>	<b>51</b>	<b>47</b>	<b>46</b>			
	[7.9]	[1035]	[1990]	[3095]	[3944]	[4953]	[5811]	TORQUE [LB-IN] TORQUE (N•M) SPEED (RPM)		
	30	<b>118</b>	<b>117</b>	<b>112</b>	<b>109</b>	<b>107</b>	<b>106</b>			
Flow (L/min)	[10.6]	[1017]	[1990]	[3078]	[3909]	[4882]	[5749]			
	40	<b>160</b>	<b>156</b>	<b>152</b>	<b>150</b>	<b>146</b>	<b>142</b>			
	[13.2]	[973]	[1946]	[3051]	[3874]	[4829]	[5704]			
	50	<b>202</b>	<b>200</b>	<b>198</b>	<b>196</b>	<b>195</b>	<b>192</b>			
Max cont	[15.8]	[929]	[1946]	[3007]	[3847]	[4793]	[5678]	Max cont.		
	60	<b>242</b>	<b>239</b>	<b>237</b>	<b>234</b>	<b>231</b>	<b>229</b>			
Max int.	[19.8]	[840]	[1901]	[2989]	[3803]	[4749]	[5642]	Max int.		
	75	<b>300</b>	<b>296</b>	<b>293</b>	<b>286</b>	<b>282</b>	<b>278</b>			
	[23.8]	[796]	[1813]	[2936]	[3714]	[4687]	[5589]			
	90	<b>360</b>	<b>354</b>	<b>348</b>	<b>340</b>	<b>332</b>	<b>326</b>			

### YMSs 315

		[19.20 in <sup>3</sup> /rev] 314.5 cm <sup>3</sup> /rev.					Max cont.	Max int.		
		[507]	[1015]	[1522]	[1740]	[2030]	[2682]	[PSI]		
		3.5	7	10.5	12	14	18.5	MPa		
GPM	[3.9]	[1415]	[2830]	[4112]	[4908]	[5749]	[6615]			
	15	<b>48</b>	<b>47</b>	<b>45</b>	<b>43</b>	<b>40</b>	<b>38</b>			
	[7.9]	[1459]	[2848]	[4139]	[4953]	[5819]	[6651]	TORQUE [LB-IN] TORQUE (N•M) SPEED (RPM)		
	30	<b>94</b>	<b>92</b>	<b>90</b>	<b>89</b>	<b>86</b>	<b>85</b>			
Flow (L/min)	[10.6]	[1415]	[2742]	[4042]	[4829]	[5678]	[6553]			
	40	<b>125</b>	<b>123</b>	<b>120</b>	<b>118</b>	<b>116</b>	<b>115</b>			
	[13.2]	[1371]	[2697]	[3980]	[4758]	[5634]	[6509]			
	50	<b>158</b>	<b>156</b>	<b>153</b>	<b>150</b>	<b>147</b>	<b>145</b>			
Max cont	[15.8]	[1344]	[2671]	[3909]	[4705]	[5589]	[6474]	Max cont.		
	60	<b>175</b>	<b>174</b>	<b>170</b>	<b>164</b>	<b>162</b>	<b>159</b>			
Max int.	[19.8]	[1282]	[2609]	[3856]	[4643]	[5554]	[6421]	Max int.		
	75	<b>236</b>	<b>234</b>	<b>230</b>	<b>227</b>	<b>225</b>	<b>222</b>			
	[23.8]	[1167]	[2476]	[3803]	[4599]	[5501]	[6394]			
	90	<b>285</b>	<b>282</b>	<b>280</b>	<b>276</b>	<b>273</b>	<b>270</b>			

### YMSS 37

		[22.58 in <sup>3</sup> /rev] 370 cm <sup>3</sup> /rev.					Max cont.	Max int.		
		[507]	[1015]	[1305]	[1450]	[1740]	[2030]	[PSI]		
		3.5	7	9	10	12	14	MPa		
GPM	[3.9]	[1636]	[3202]	[4192]	[4528]	[5200]	[5837]			
	15	<b>40</b>	<b>39</b>	<b>38</b>	<b>37</b>	<b>35</b>	<b>33</b>			
	[7.9]	[1627]	[3219]	[4201]	[4546]	[5218]	[5846]	TORQUE [LB-IN] TORQUE (N•M) SPEED (RPM)		
	30	<b>80</b>	<b>78</b>	<b>77</b>	<b>76</b>	<b>74</b>	<b>72</b>			
Flow (L/min)	[10.6]	[1592]	[3202]	[4183]	[4537]	[5200]	[5828]			
	40	<b>106</b>	<b>104</b>	<b>103</b>	<b>102</b>	<b>100</b>	<b>97</b>			
	[13.2]	[1415]	[3184]	[4174]	[4519]	[5183]	[5819]			
	50	<b>133</b>	<b>131</b>	<b>130</b>	<b>129</b>	<b>128</b>	<b>125</b>			
Max cont	[15.8]	[1327]	[3175]	[4166]	[4510]	[5174]	[5811]	Max cont.		
	60	<b>157</b>	<b>156</b>	<b>155</b>	<b>154</b>	<b>152</b>	<b>150</b>			
Max int.	[19.8]	[1150]	[3122]	[4112]	[4457]	[5165]	[5757]	Max int.		
	75	<b>200</b>	<b>198</b>	<b>196</b>	<b>195</b>	<b>194</b>	<b>193</b>			
	[23.8]	[929]	[3095]	[4086]	[4422]	[5130]	[5722]			
	90	<b>238</b>	<b>235</b>	<b>234</b>	<b>232</b>	<b>230</b>	<b>227</b>			

## MOUNTING DATA

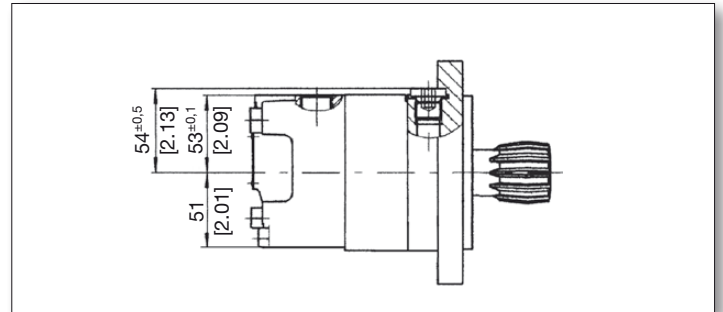
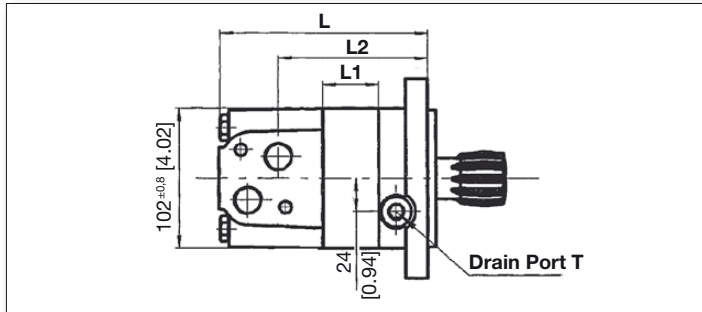

MODEL	[INCHES]			MILLIMETERS		
	L	L1	L2	L	L1	L2
YMSS 80	[5.12]	[0.52]	[3.39]	130	13	86
YMSS 100	[5.28]	[0.67]	[3.55]	134	17	90
YMSS 125	[5.48]	[0.87]	[3.74]	139	22	95
YMSS 160	[5.69]	[12.90]	[3.96]	144.5	27.5	100.5
YMSS 200	[5.99]	[1.39]	[4.26]	152	35.1	108
YMSS 250	[6.46]	[1.85]	[4.73]	164	47	120
YMSS 315	[6.93]	[2.33]	[5.20]	176	59	132
YMSS 375	[7.41]	[2.80]	[5.67]	188	71	144

NOTE: THE THICKNESS OF THE STATOR AND ROTOR IS THE DIMENSION OF L1 PLUS 3MM

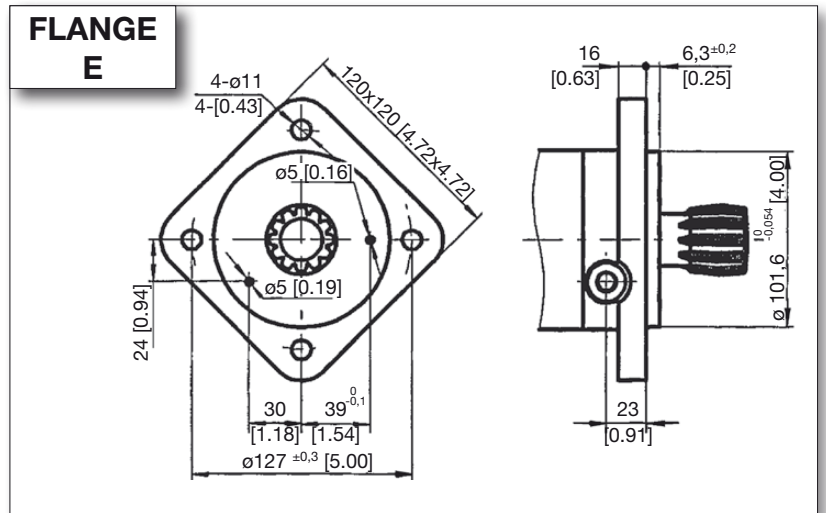
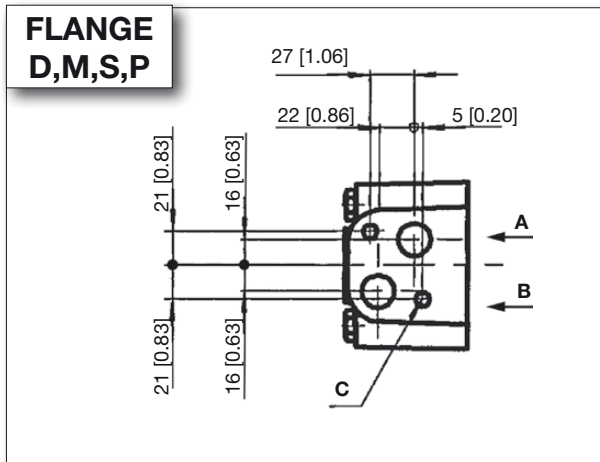
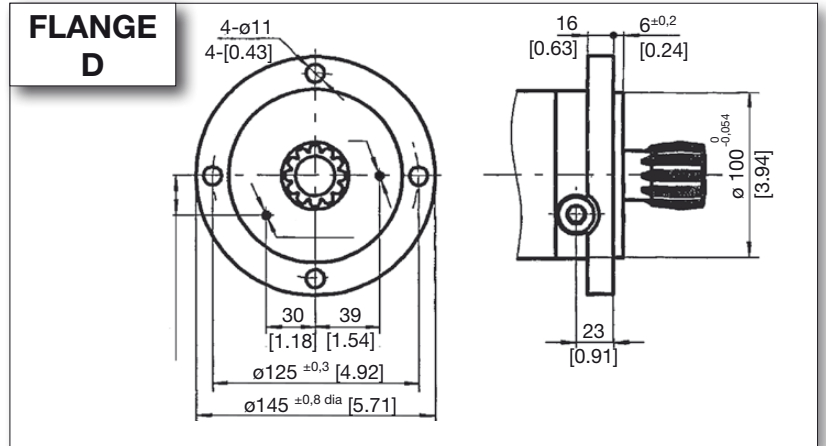

## PORT & DRAIN PORT ORDERING CODES

ORDER CODE	D	DEPTH	M	DEPTH	S	DEPTH	P	DEPTH
PORTS - A and B	G 1/2	18 mm	M22 X 1.5	18 mm	7/8-14 O-RING	18 mm	1/2-14NPTF	15 mm
TANK PORT - T	G 1/4	12 mm	M14 X 1.5	12 mm	7/16-20UNF	12 mm	7/16-20UNF	12 mm
BOLTS - C	2-M10	13 mm	2-M10	13 mm	2-3/8-16UNC	13 mm	2-3/8-16UNC	13 mm

## MOUNTING DATA

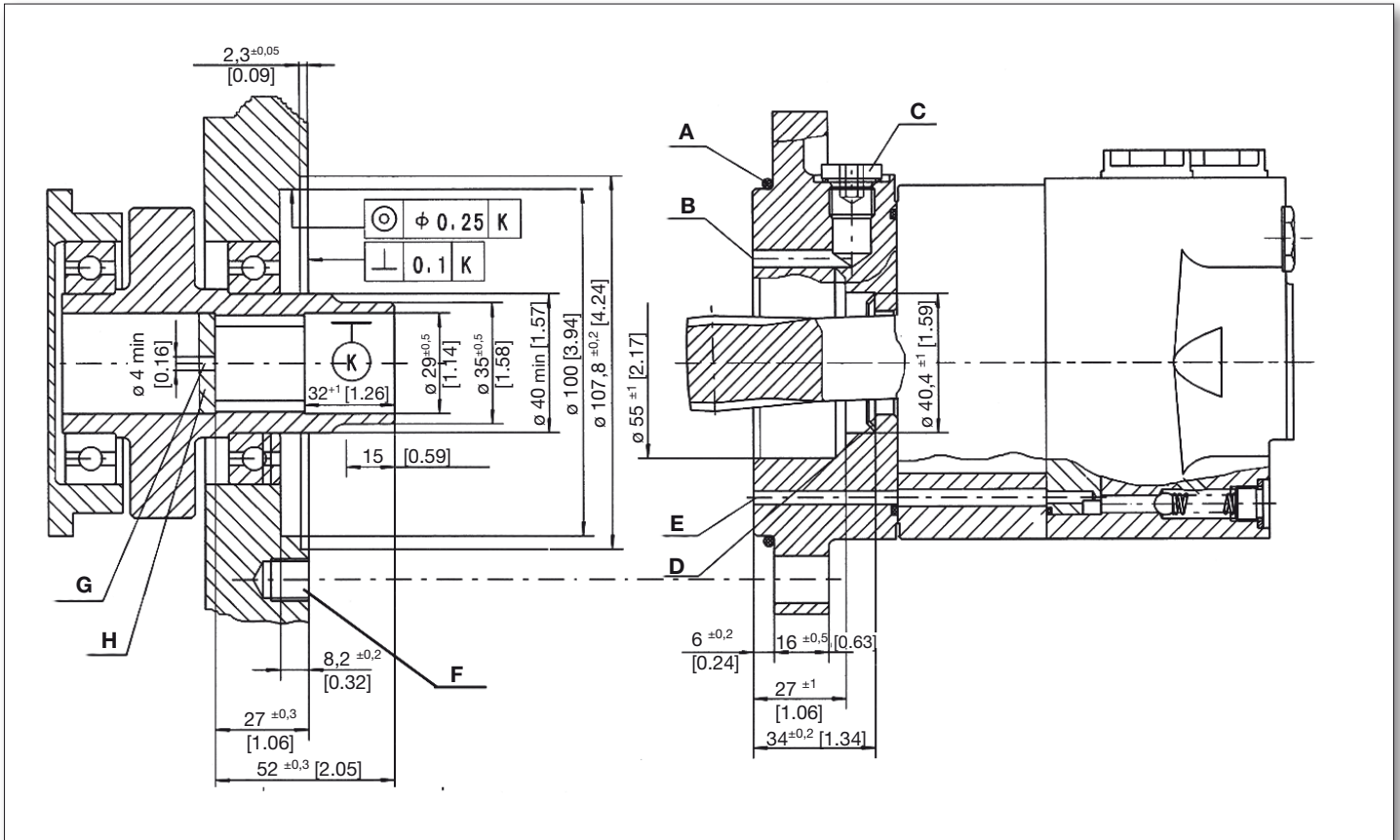

- A: O-ring;100x3
- B: External drain channel
- C: Drain connection G 1/4;12 mm deep
- D: Conical seal ring
- E: Internal drain channel
- F: M10;min. 15mm deep
- G: Oil circulation hole
- H: Hardened stop plate

### INTERNAL SPLINE DATA FOR THE ATTACHED COMPONENT

FILLET ROOT SIDE FIT		mm
NUMBER OF TEETH	Z	12
DIAMETRAL PITCH	DP	12/24
PRESSURE ANGLE	$\alpha_D$	30°
PITCH DIA.	D	Ø25.4
MAJOR DIA.	$D_{ei}$	Ø28 <sup>0</sup> <sub>-0.1</sub>
MINOR DIA.	$D_{ii}$	Ø23 <sup>+0.033</sup> <sub>0</sub>
SPACE WIDTH CIRCULAR	E	4.308 ±0.02

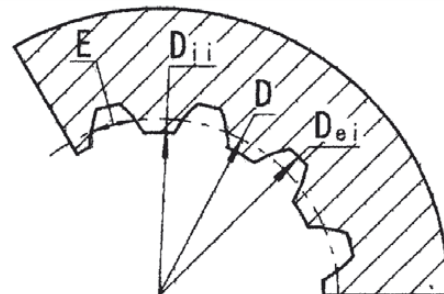

Hardening Specification: HRC 62±2  
Effective case depth 0.7±0.2

## ORDERING INFORMATION

	1	2	3	4	5	6	7
YMSS							

1	2		3		4		5		6		7								
DISP.	FLANGE		OUTPUT SHAFT		PORT AND DRAIN PORT		ROTATION DIRECTION		PAINT		SPECIAL OPTIONS								
80	D	4-Ø13.5 Circle-flange Ø125, pilot Ø100×6	None	Short shaft DP12/24	D	G1/2 Manifold Mount 2-M10, G1/4	NONE	STANDARD	00	NO PAINT	NONE	STANDARD							
100	E	4-Ø13.5 Square-flange Ø127, pilot Ø101.6×6.3			M	M22×1.5 Manifold Mount 2-M10, M14×1.5						R	OPPOSITE	LL	LOW LEAKAGE				
125					S	7/8-14 O-ring manifold 2-3/8- 16 UNC, 7/16-20UNF								B	BLACK	FR	FREE RUNNING		
160					P	1/2-14 NPTF Manifold 2-3/8-16 UNC, 7/16-20UNF										LSV	LOW SPEED VALVE		
200																			
250																			
315																			
375																			

### ORDERING CODE:

All options have been determined with letters, numbers or combinations. All boxes must be filled with proper codes. If specification is not in the table, please contact us with your requirements.

# YMSJ

The **YMSJ** series motors incorporates the advanced **GEROLOR** gear set with reduces internal friction to a minimum. A “DISC VALVE” distribution system which is internally balanced to reduce friction, leakage and permits better speed control producing higher efficiency, smoother rotation, higher speed and pressure.

The series has many sizes and options to make it very flexible for many applications

## SPECIFICATIONS

Distribution Type	Model	Displacement		Max. Operating Pressure		Speed Range Continuous	Max. Output Power	
		[in <sup>3</sup> ./rev]	[4.88 ~ 22.88]	[PSI]	[3263]		[HP]	[27]
Disc Distribution	YMSJ	cm <sup>3</sup> /rev.	80 ~ 375	MPa	22.5	30 ~ 800	Kw	20

## QUICK REFERENCE GUIDE

### YMSJ SERIES QUICK REFERENCE:

Displacements				
[in <sup>3</sup> ./rev]	cm <sup>3</sup> /rev.			
[4.92]	80.6	FLOW UP TO	90 LPM	[23.78 GPM]
[6.15]	100.8	PRESSURE UP TO	22.5 MPA	[3262 PSI]
[7.63]	125	TORQUE UP TO	1100 NM	[3944 LB. IN.]
[9.59]	157.2	SPEED UP TO	470 RPM	
[12.2]	200			
[15.38]	252			
[19.19]	314.5			
[22.57]	370			

**Shaft Seals:** Standard high pressure shaft seals permit applications in series or without drain line when required

**Low Speed Valving:** These motors are manufactured following strict procedures to reduce tolerances between all components to permit lower speed, higher efficiency and smoother rotation at very low speeds. These motors are not for high speed or low pressure applications.

**Free Running:** Motors with this option have increased clearances in the rotor set. This allows improved mechanical efficiency, longer life and better performance for high-speed / high-flow applications, winch or similar applications where the motor is cross-ported to allow manual free turning also remay benefit from this option to allow smoother easier free turning of the motor. Last, applications which have many reversals or high pressure spikes can also benefit since the pressure spikes will be reduced by relieving (cross-porting) such spikes internally in the motor. The trade off of these benefits is a slight reduction in volumetric efficiency, particularly at high pressure conditions.

**Special Motors:** These motors have special options like nickel plated shafts or housings for applications in corrosive environments.

### APPLICATION GUIDELINES:

For optimum results the following working conditions are recommended:

- \* Oil temperature should be between 20° - 60° C [68° - 180° F]
- \* Oil filter of 10 - 20 micron
- \* Oil viscosity 42 - 74 mm<sup>2</sup>/s CSA at 40° C
- \* For longer life we suggest the motor at start up, run for a shorter period of time (one hour) at no more than 30% of rated speed and pressure.



## SPECIFICATION DATA

For individual motor performance chart consult equivalent YMS series data

DISTRIBUTION TYPE		YMSJ 80	YMSJ 100	YMSJ 125	YMSJ 160	YMSJ 200	YMSJ 250	YMSJ 315	YMSJ 375	
GEOMETRIC DISPLACEMENT	[in <sup>3</sup> ./rev.]	[4.92]	[6.16]	[7.63]	[9.60]	[12.21]	[15.38]	[19.20]	[22.58]	
	cm <sup>3</sup> /rev.	<b>80.6</b>	<b>100.8</b>	<b>125</b>	<b>157.2</b>	<b>200</b>	<b>252</b>	<b>314.5</b>	<b>370</b>	
MAX. SPEED RPM	CONT.	800	748	600	470	375	300	240	200	
	INT.	<b>988</b>	<b>900</b>	<b>720</b>	<b>560</b>	<b>450</b>	<b>360</b>	<b>280</b>	<b>240</b>	
MAX. TORQUE [LB. IN.] N*M	CONT.	[LB. IN.]	[1680]	[2123]	[2742]	[2795]	[3538]	[3980]	[4953]	[4740]
		N*M	<b>190</b>	<b>240</b>	<b>310</b>	<b>316</b>	<b>400</b>	<b>450</b>	<b>560</b>	<b>536</b>
	INT.	[LB. IN.]	[2123]	[2653]	[3272]	[3803]	[4121]	[4776]	[5819]	[5704]
		N*M	<b>240</b>	<b>300</b>	<b>370</b>	<b>430</b>	<b>466</b>	<b>540</b>	<b>659</b>	<b>645</b>
	PEAK	[LB. IN.]	[2299]	[2830]	[3538]	[4174]	[5749]	[6102]	[6545]	[6642]
		N*M	<b>260</b>	<b>320</b>	<b>400</b>	<b>472</b>	<b>650</b>	<b>690</b>	<b>740</b>	<b>751</b>
MAX. OUTPUT [HP] KW	CONT.	[HP]	[21]	[25]	[26]	[21]	[21]	[19]	[19]	[16]
		KW	<b>15.9</b>	<b>18.</b>	<b>19.5</b>	<b>15.6</b>	<b>15.7</b>	<b>14.1</b>	<b>14.1</b>	<b>11.8</b>
	INT.	[HP]	[27]	[31]	[32]	[29]	[25]	[23]	[25]	[23]
		KW	<b>20.1</b>	<b>23.5</b>	<b>23.2</b>	<b>21.2</b>	<b>18.3</b>	<b>17.0</b>	<b>18.9</b>	<b>17</b>
MAX. PRES- SURE DROP [PSI] MPa	CONT.	[PSI]	[2538]	[2538]	[2538]	[2175]	[2030]	[1813]	[1740]	[1450]
		MPa	<b>17.5</b>	<b>17.5</b>	<b>17.5</b>	<b>15</b>	<b>14</b>	<b>12.5</b>	<b>12</b>	<b>10</b>
	INT.	[PSI]	[3045]	[3045]	[3045]	[3045]	[2320]	[2320]	[2030]	[1740]
		MPa	<b>21</b>	<b>21</b>	<b>21</b>	<b>21</b>	<b>16</b>	<b>16</b>	<b>14</b>	<b>12</b>
	PEAK	[PSI]	[3263]	[3263]	[3263]	[3263]	[3263]	[2900]	[2683]	[2030]
		MPa	<b>22.5</b>	<b>22.5</b>	<b>22.5</b>	<b>22.5</b>	<b>22.5</b>	<b>20</b>	<b>18.5</b>	<b>14</b>
MAX. FLOW [GPM] L/MIN	CONT.	[GPM]	[17.1]	[19.8]	[19.8]	[19.8]	[19.8]	[19.8]	[19.8]	[19.8]
		L/MIN	<b>65</b>	<b>75</b>	<b>75</b>	<b>75</b>	<b>75</b>	<b>75</b>	<b>75</b>	<b>75</b>
	INT.	[GPM]	[21.1]	[23.7]	[23.7]	[23.]	[23.7]	[23.7]	[23.7]	[23.7]
		L/MIN	<b>80</b>	<b>90</b>	<b>90</b>	<b>90</b>	<b>90</b>	<b>90</b>	<b>90</b>	<b>90</b>
MAX. INLET PRESSURE [PSI] MPa	CONT.	[PSI]	[3625]	[3625]	[3625]	[3625]	[3625]	[3625]	[3625]	[3625]
		MPa	<b>25</b>	<b>25</b>	<b>25</b>	<b>25</b>	<b>25</b>	<b>25</b>	<b>25</b>	<b>25</b>
	INT.	[PSI]	[4350]	[4350]	[4350]	[4350]	[4350]	[4350]	[4350]	[4350]
		MPa	<b>30</b>	<b>30</b>	<b>30</b>	<b>30</b>	<b>30</b>	<b>30</b>	<b>30</b>	<b>30</b>
WEIGHT [LB] KG	[LB]	[22]	[22]	[23]	[24]	[24]	[26]	[27]	[28]	
	KG	<b>9.8</b>	<b>10</b>	<b>10.3</b>	<b>10.7</b>	<b>11.1</b>	<b>11.6</b>	<b>12.3</b>	<b>12.6</b>	

\* Continuous pressure:

\* Intermittent pressure:

\* Peak pressure:

Max. value of operating motor continuously.

Max. value of operating motor in 6 seconds per minute.

Max. value of operating motor in 0.6 second per minute.

## PERFORMANCE DATA

YMSJ 80

		[4.92 in <sup>3</sup> /rev] 80.6 cm <sup>3</sup> /rev.				Max cont.	Max int.		
		[507]	[1015]	[1522]	[2030]	[2537]	[3045]	[3262]	[PSI]
		3.5	7	10.5	14	17.5	21	22.5	MPa
GPM	[3.9]	[310]	[707]	[1061]	[1397]	[1724]	[2078]	[2202]	
	L/min	35	80	120	158	195	235	249	
15	[7.9]	<b>180</b>	<b>174</b>	<b>168</b>	<b>164</b>	<b>158</b>	<b>151</b>	<b>143</b>	TORQUE (LB-IN) TORQUE (N•M) SPEED (RPM)
	30	35	80	120	158	195	240	260	
Flow (L/min)	[10.6]	[310]	[699]	[1052]	[1371]	[1707]	[2070]	[2211]	
	L/min	35	79	119	155	193	234	250	
40	[13.2]	<b>482</b>	<b>473</b>	<b>464</b>	<b>453</b>	<b>444</b>	<b>434</b>	<b>415</b>	
	50	30	77	117	153	192	232	248	
Max cont.	[15.8]	[265]	[681]	[1035]	[1353]	[1698]	[2052]	[2193]	
	L/min	30	77	117	153	192	232	248	
60	[19.8]	<b>602</b>	<b>594</b>	<b>587</b>	<b>569</b>	<b>560</b>	<b>551</b>	<b>522</b>	Max cont.
	75	28	77	117	153	192	232	247	
Max int.	[23.8]	[221]	[663]	[1008]	[1344]	[1680]	[2034]	[2167]	Max int.
	L/min	25	75	114	152	190	230	245	
90	[23.8]	<b>840</b>	<b>832</b>	<b>817</b>	<b>796</b>	<b>786</b>	<b>777</b>	<b>737</b>	
	90	24	73	110	150	185	225	240	

YMSJ 100

		[6.16 in <sup>3</sup> /rev] 100.8 cm <sup>3</sup> /rev.				Max cont.	Max int.		
		[507]	[1015]	[1522]	[2030]	[2537]	[3045]	[3262]	[PSI]
		3.5	7	10.5	14	17.5	21	22.5	MPa
GPM	[3.9]	[425]	[840]	[1327]	[1769]	[2211]	[2556]	[2742]	
	L/min	48	95	150	200	250	289	310	
15	[7.9]	<b>146</b>	<b>144</b>	<b>139</b>	<b>135</b>	<b>130</b>	<b>120</b>	<b>105</b>	TORQUE (LB-IN) TORQUE (N•M) SPEED (RPM)
	30	45	94	146	198	250	295	317	
Flow (L/min)	[10.6]	[380]	[787]	[1256]	[1733]	[2193]	[2591]	[2795]	
	L/min	43	89	142	196	248	293	316	
40	[13.2]	<b>387</b>	<b>384</b>	<b>374</b>	<b>359</b>	<b>350</b>	<b>335</b>	<b>320</b>	
	50	40	88	135	194	247	292	315	
Max cont.	[15.8]	[327]	[778]	[1194]	[1716]	[2184]	[2582]	[2786]	
	L/min	37	88	132	185	244	289	312	
60	[19.8]	<b>588</b>	<b>584</b>	<b>574</b>	<b>562</b>	<b>550</b>	<b>538</b>	<b>520</b>	Max cont.
	75	35	80	130	180	240	286	310	
Max int.	[23.8]	[310]	[708]	[1150]	[1592]	[2123]	[2529]	[2742]	Max int.
	L/min	35	80	130	180	240	286	310	
90	[23.8]	<b>740</b>	<b>735</b>	<b>720</b>	<b>705</b>	<b>696</b>	<b>676</b>	<b>653</b>	
	90	30	75	124	170	236	277	303	

YMSJ 125

		[7.63 in <sup>3</sup> /rev] 125 cm <sup>3</sup> /rev.				Max cont.	Max int.		
		[507]	[1015]	[1522]	[2030]	[2537]	[3045]	[3262]	[PSI]
		3.5	7	10.5	14	17.5	21	22.5	MPa
GPM	[3.9]	[486]	[1061]	[1557]	[2167]	[2733]	[3087]	[3317]	
	L/min	55	120	176	245	309	349	375	
15	[7.9]	<b>112</b>	<b>110</b>	<b>103</b>	<b>96</b>	<b>93</b>	<b>90</b>	<b>84</b>	TORQUE (LB-IN) TORQUE (N•M) SPEED (RPM)
	30	55	120	175	250	324	375	408	
Flow (L/min)	[10.6]	[486]	[1061]	[1548]	[2211]	[2865]	[3317]	[3608]	
	L/min	55	120	175	250	324	370	408	
40	[13.2]	<b>302</b>	<b>298</b>	<b>292</b>	<b>284</b>	<b>276</b>	<b>268</b>	<b>260</b>	
	50	442	1017	1557	2193	2830	3272	3591	
Max cont.	[15.8]	[398]	[999]	[1512]	[2167]	[2865]	[3255]	[3591]	
	L/min	45	113	171	245	324	368	406	
60	[19.8]	<b>456</b>	<b>448</b>	<b>443</b>	<b>439</b>	<b>425</b>	<b>406</b>	<b>393</b>	Max cont.
	75	45	110	167	240	314	370	401	
Max int.	[23.8]	[354]	[929]	[1433]	[2096]	[2733]	[3228]	[3520]	Max int.
	L/min	40	105	162	237	309	365	398	
90	[23.8]	<b>685</b>	<b>676</b>	<b>670</b>	<b>659</b>	<b>644</b>	<b>625</b>	<b>610</b>	
	90	40	105	162	237	309	365	398	

YMSJ 160

		[9.60 in <sup>3</sup> /rev] 157.2 cm <sup>3</sup> /rev.				Max cont.	Max int.		
		[507]	[1015]	[1522]	[2030]	[2537]	[3045]	[3262]	[PSI]
		3.5	7	10.5	14	17.5	21	22.5	MPa
GPM	[3.9]	[619]	[1238]	[1813]	[2697]	[3281]	[3803]	[4183]	
	L/min	70	140	205	305	371	430	473	
15	[7.9]	<b>91</b>	<b>88</b>	<b>84</b>	<b>78</b>	<b>76</b>	<b>74</b>	<b>58</b>	TORQUE (LB-IN) TORQUE (N•M) SPEED (RPM)
	30	75	150	214	321	380	427	490	
Flow (L/min)	[10.6]	[619]	[1327]	[1901]	[2830]	[3343]	[3759]	[4316]	
	L/min	70	150	215	320	378	425	488	
40	[13.2]	<b>248</b>	<b>244</b>	<b>239</b>	<b>229</b>	<b>224</b>	<b>217</b>	<b>204</b>	
	50	65	145	215	316	378	425	482	
Max cont.	[15.8]	[575]	[1282]	[1901]	[2795]	[3343]	[3759]	[4263]	
	L/min	65	145	215	316	378	425	482	
60	[19.8]	<b>312</b>	<b>308</b>	<b>304</b>	<b>294</b>	<b>288</b>	<b>280</b>	<b>270</b>	Max cont.
	75	65	145	214	315	375	424	482	
Max int.	[23.8]	[531]	[1221]	[1840]	[2751]	[3317]	[3714]	[4263]	Max int.
	L/min	60	138	208	311	375	420	482	
90	[23.8]	<b>470</b>	<b>465</b>	<b>458</b>	<b>447</b>	<b>436</b>	<b>426</b>	<b>414</b>	
	90	56	130	200	308	370	414	482	

## PERFORMANCE DATA

**YMSJ 200**  
[12.21 in<sup>3</sup>/rev] 200 cm<sup>3</sup>/rev. Max cont. Max int.

	[507]	[1015]	[1522]	[2030]	[2537]	[3262]	[PSI]
	3.5	7	10.5	14	17.5	22.5	MPa
GPM	[3.9]	[787]	[1680]	[2609]	[3538]	[4281]	[5377]
	15	<b>73</b>	<b>71</b>	<b>68</b>	<b>64</b>	<b>60</b>	<b>52</b>
TORQUE [LB-IN]	[7.9]	[769]	[1680]	[2600]	[3529]	[4289]	[5306]
	30	<b>87</b>	<b>190</b>	<b>294</b>	<b>399</b>	<b>485</b>	<b>600</b>
TORQUE (N•M)	[10.6]	[761]	[1663]	[2582]	[3511]	[4272]	[5253]
	40	<b>86</b>	<b>188</b>	<b>292</b>	<b>397</b>	<b>483</b>	<b>594</b>
SPEED (RPM)	[13.2]	[708]	[1627]	[2565]	[3493]	[4245]	[5218]
	50	<b>247</b>	<b>245</b>	<b>243</b>	<b>240</b>	<b>235</b>	<b>226</b>
Flow (L/min)	[15.8]	[654]	[1574]	[2530]	[3449]	[4201]	[5147]
	60	<b>74</b>	<b>178</b>	<b>286</b>	<b>390</b>	<b>475</b>	<b>582</b>
Max cont.	[19.8]	[513]	[1415]	[2432]	[3317]	[4068]	[5041]
	75	<b>58</b>	<b>160</b>	<b>275</b>	<b>375</b>	<b>460</b>	<b>570</b>
Max int.	[23.8]	[433]	[1309]	[2299]	[3140]	[3936]	[4908]
	90	<b>49</b>	<b>148</b>	<b>260</b>	<b>355</b>	<b>445</b>	<b>555</b>
							Max cont.
							Max int.

**YMSJ 250**  
[15.38 in<sup>3</sup>/rev] 252 cm<sup>3</sup>/rev. Max cont. Max int.

	[507]	[1015]	[1522]	[2030]	[2537]	[3262]	[PSI]
	3.5	7	10.5	14	17.5	22.5	MPa
GPM	[3.9]	[1035]	[2034]	[3140]	[3980]	[4900]	[5766]
	15	<b>58</b>	<b>55</b>	<b>52</b>	<b>51</b>	<b>47</b>	<b>46</b>
TORQUE [LB-IN]	[7.9]	[1035]	[1990]	[3095]	[3944]	[4953]	[5811]
	30	<b>117</b>	<b>225</b>	<b>350</b>	<b>446</b>	<b>560</b>	<b>657</b>
TORQUE (N•M)	[10.6]	[1017]	[1990]	[3078]	[3909]	[4882]	[5749]
	40	<b>115</b>	<b>225</b>	<b>348</b>	<b>442</b>	<b>552</b>	<b>650</b>
SPEED (RPM)	[13.2]	[973]	[1946]	[3051]	[3874]	[4829]	[5704]
	50	<b>110</b>	<b>220</b>	<b>345</b>	<b>438</b>	<b>546</b>	<b>645</b>
Flow (L/min)	[15.8]	[929]	[1946]	[3007]	[3847]	[4793]	[5678]
	60	<b>105</b>	<b>220</b>	<b>340</b>	<b>435</b>	<b>542</b>	<b>642</b>
Max cont.	[19.8]	[840]	[1901]	[2989]	[3803]	[4749]	[5642]
	75	<b>95</b>	<b>215</b>	<b>338</b>	<b>430</b>	<b>537</b>	<b>638</b>
Max int.	[23.8]	[796]	[1813]	[2936]	[3714]	[4687]	[5589]
	90	<b>90</b>	<b>205</b>	<b>332</b>	<b>420</b>	<b>530</b>	<b>632</b>
							Max cont.
							Max int.

**YMSJ 315**  
[19.20 in<sup>3</sup>/rev] 314.5 cm<sup>3</sup>/rev. Max cont. Max int.

	[507]	[1015]	[1522]	[1740]	[2030]	[2682]	[PSI]
	3.5	7	10.5	12	14	18.5	MPa
GPM	[3.9]	[1415]	[2830]	[4112]	[4908]	[5749]	[6615]
	15	<b>160</b>	<b>320</b>	<b>465</b>	<b>555</b>	<b>650</b>	<b>748</b>
TORQUE [LB-IN]	[7.9]	[1459]	[2848]	[4139]	[4953]	[5819]	[6651]
	30	<b>165</b>	<b>322</b>	<b>468</b>	<b>560</b>	<b>658</b>	<b>752</b>
TORQUE (N•M)	[10.6]	[1415]	[2742]	[4042]	[4829]	[5678]	[6553]
	40	<b>160</b>	<b>310</b>	<b>457</b>	<b>546</b>	<b>642</b>	<b>741</b>
SPEED (RPM)	[13.2]	[1371]	[2697]	[3980]	[4758]	[5634]	[6509]
	50	<b>155</b>	<b>305</b>	<b>450</b>	<b>538</b>	<b>637</b>	<b>736</b>
Flow (L/min)	[15.8]	[1344]	[2671]	[3909]	[4705]	[5589]	[6474]
	60	<b>152</b>	<b>302</b>	<b>442</b>	<b>532</b>	<b>632</b>	<b>732</b>
Max cont.	[19.8]	[1282]	[2609]	[3856]	[4643]	[5554]	[6421]
	75	<b>145</b>	<b>295</b>	<b>436</b>	<b>525</b>	<b>628</b>	<b>726</b>
Max int.	[23.8]	[1167]	[2476]	[3803]	[4599]	[5501]	[6394]
	90	<b>132</b>	<b>280</b>	<b>430</b>	<b>520</b>	<b>622</b>	<b>723</b>
							Max cont.
							Max int.

**YMSJ 37**  
[22.58 in<sup>3</sup>/rev] 370 cm<sup>3</sup>/rev. Max cont. Max int.

	[507]	[1015]	[1305]	[1450]	[1740]	[2030]	[PSI]
	3.5	7	9	10	12	14	MPa
GPM	[3.9]	[1636]	[3202]	[4192]	[4528]	[5200]	[5837]
	15	<b>185</b>	<b>362</b>	<b>474</b>	<b>512</b>	<b>588</b>	<b>660</b>
TORQUE [LB-IN]	[7.9]	[1627]	[3219]	[4201]	[4546]	[5218]	[5846]
	30	<b>184</b>	<b>364</b>	<b>475</b>	<b>514</b>	<b>590</b>	<b>661</b>
TORQUE (N•M)	[10.6]	[1592]	[3202]	[4183]	[4537]	[5200]	[5828]
	40	<b>180</b>	<b>362</b>	<b>473</b>	<b>513</b>	<b>588</b>	<b>659</b>
SPEED (RPM)	[13.2]	[1415]	[3184]	[4174]	[4519]	[5183]	[5819]
	50	<b>160</b>	<b>360</b>	<b>472</b>	<b>511</b>	<b>586</b>	<b>658</b>
Flow (L/min)	[15.8]	[1327]	[3175]	[4166]	[4510]	[5174]	[5811]
	60	<b>150</b>	<b>359</b>	<b>471</b>	<b>510</b>	<b>585</b>	<b>657</b>
Max cont.	[19.8]	1150]	[3122]	[4112]	[4457]	[5165]	[5757]
	75	<b>130</b>	<b>353</b>	<b>465</b>	<b>504</b>	<b>584</b>	<b>651</b>
Max int.	[23.8]	[929]	[3095]	[4086]	[4422]	[5130]	[5722]
	90	<b>105</b>	<b>350</b>	<b>462</b>	<b>500</b>	<b>580</b>	<b>647</b>
							Max cont.
							Max int.

## MOUNTING DATA

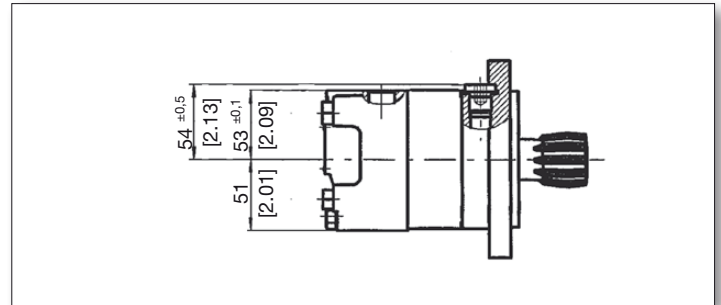
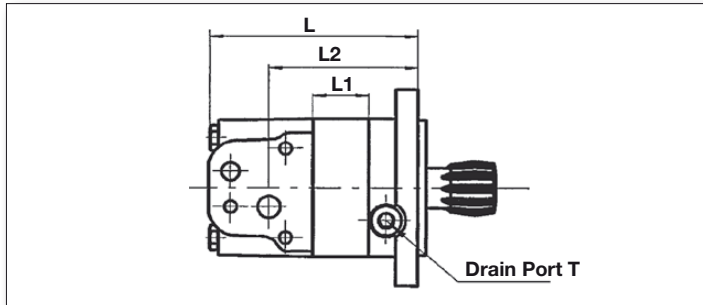

### PORTING DB, DU, SU, SB, M4

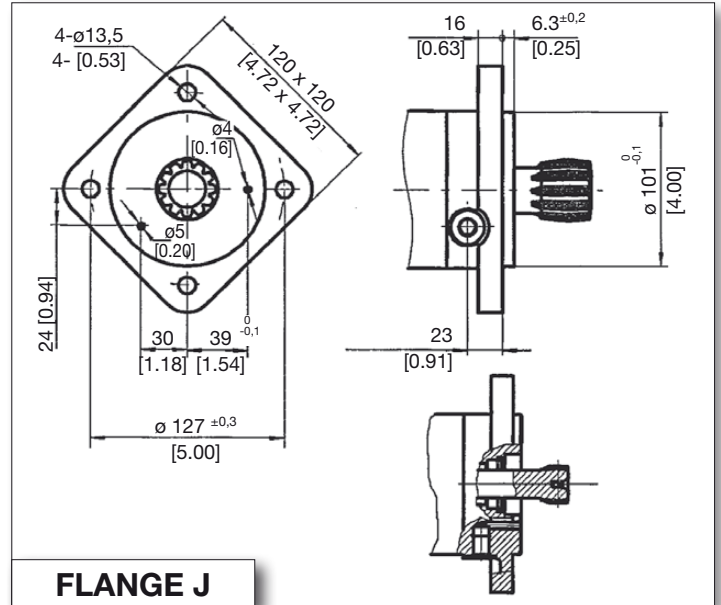
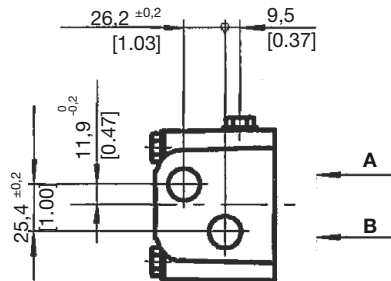

### FLANGE J

### PORTING ED

O-ring Ports  
180 Apart

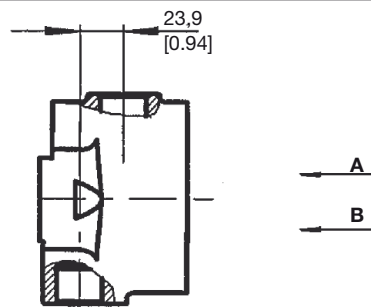

### PORTING MU, MM

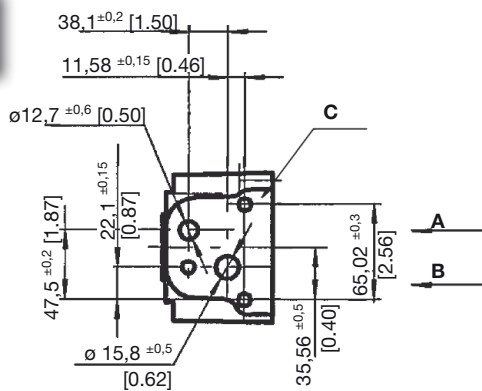

MODEL	[INCHES]			MILLIMETERS		
	L	L1	L2	L	L1	L2
YMSJ 80	[5.28]	[0.52]	[3.39]	134	13	86
YMSJ 100	[5.44]	[0.67]	[3.55]	138	17	90
YMSJ 125	[5.63]	[0.87]	[3.74]	143	22	95
YMSJ 160	[5.85]	[12.90]	[3.96]	148.5	27.5	100.5
YMSJ 200	[6.15]	[1.39]	[4.26]	156	35.1	108
YMSJ 250	[6.62]	[1.85]	[4.73]	168	47	120
YMSJ 315	[7.09]	[2.33]	[5.20]	180	59	132
YMSJ 375	[7.56]	[2.80]	[5.67]	192	71	144

- Note: 1) If the porting MU, MM, S2 is used, the dimension of L2 should be reduced by 1,5 mm and L should be reduced by 4 mm  
 2) If the port ED is used, the dimensions of the L2 should be plus 2,5 mm and L should be plus 2 mm  
 3) The thickness of the stator and rotor is the dimension of L1 + 3mm.

### PORT & DRAIN PORT ORDERING CODES

ORDER CODE	DB	DEPTH	DU	DEPTH	SU	DEPTH	SB	DEPTH	M4	DEPTH	MU	MM	DEPTH	ED	DEPTH
PORTS - A and B	G12	18 mm	G1/2	18 mm	7/8-14 O-ring	18 mm	7/8-14 O-ring	18 mm	M22x1,5	18 mm	12.7 15.8	12.7 15.8		1-1/16-12un	18 mm
TANK PORT - T	G1/4	12 mm	7/16-20UNF	12 mm	7/16-20unf	12 mm	G 1/4	12 mm	M14x1.5	12 mm	7/16-20UNF	G 1/4	12 mm	7/16-20unf	12 mm
BOLTS - C											3x3/8-16UNF	3xM10			

## DIMENSION AND MOUNTING DATA

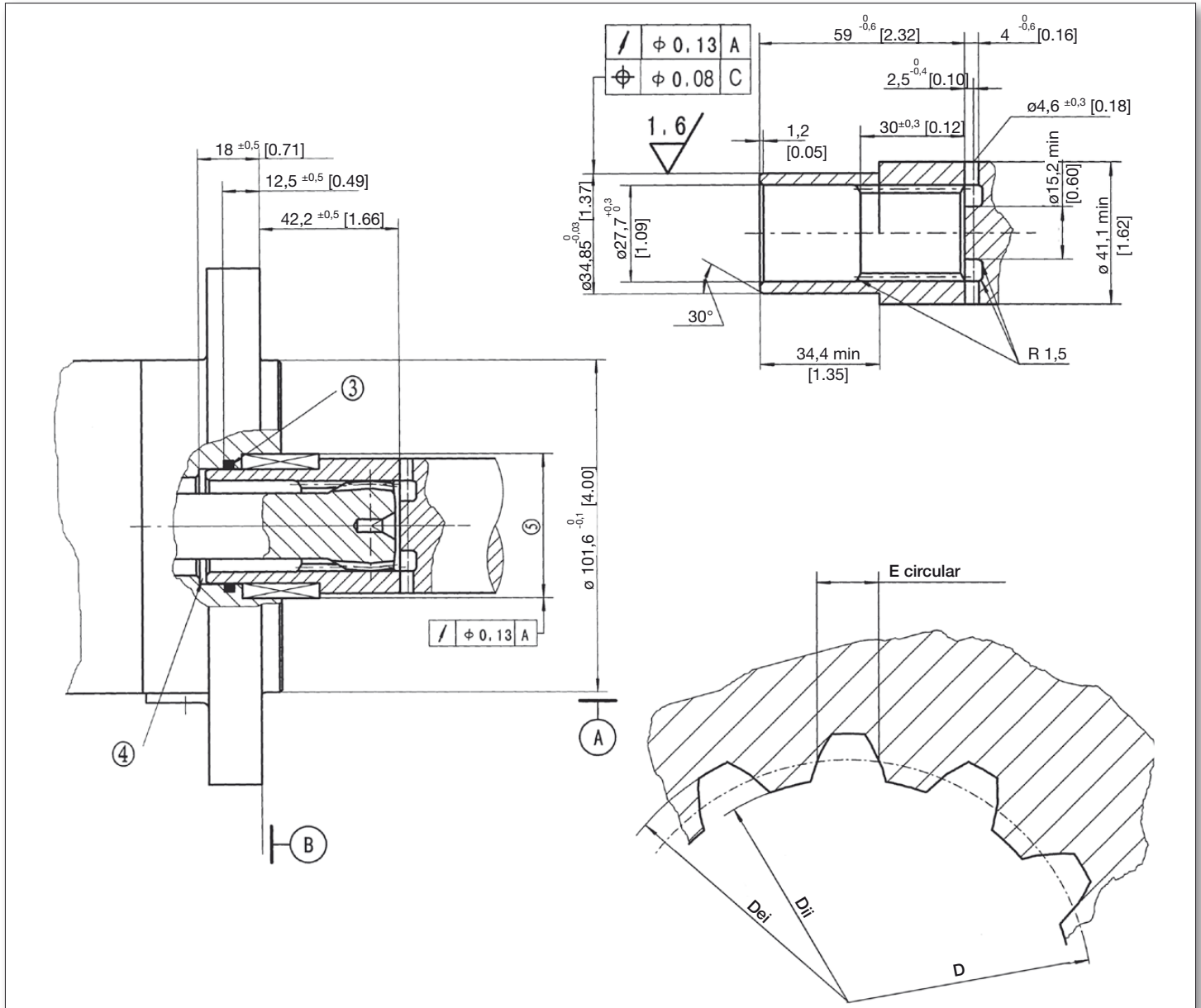

### INTERNAL SPLINE DATA FOR THE ATTACHED COMPONENT

FILLET ROOT SIDE FIT		mm
NUMBER OF TEETH	Z	12
DIAMETRAL PITCH	DP	12/24
PRESSURE ANGLE	$\alpha_D$	30°
PITCH DIA.	D	$\phi$ 25.4
MAJOR DIA.	Dei	$\phi$ 27.6 <sup>+0.14</sup> <sub>0</sub>
MINOR DIA.	Dii	$\phi$ 23.1 <sup>+0.12</sup> <sub>0</sub>
SPACE WIDTH CIRCULAR	E	4.282 ±0.036
DIMENSION BETWEEN TWO PINS (Ø4)	Me	19.02-19.19

- Internal spline in mating part to be as follows: Material to be ASTM A304, 8620H. Carborize to a hardness of 58-62 HRC with case depth (to 50HRC) of 0.75-1 [0.30-.040] (dimensions apply after heat treat).
- Mating part to have critical dimensions as shown. Oil holes must be provided and open for proper oil circulation.
- Some means of maintaining clearance between shaft and mounting flange must be provided
- Seal to be furnished with motor for proper oil circulation thru splines
- Counterbore designed to adapt to a standard sleeve bearing 35.040 [1.3784-1.3795] ID by 44.040-44.070 [1.7339-1.7350] O.D. (Oilite Bronze sleeve bearing AAM3544-22)

## ORDERING INFORMATION

	1	2	3	4	5	6	7
YMSJ							

1	2		3		4		5		6		7	
DISP.	FLANGE		OUTPUT SHAFT		PORT AND DRAIN PORT		ROTATION DIRECTION		PAINT		SPECIAL OPTIONS	
80	J	Square Flange ø 127, Pilot ø 101,6x6,3			MU	1/2", 5/8" Crosshole Manifold 3x3/8-16 UNC, 7/16-20 UNF			OO	NO PAINT		
100					MM	1/2", 5/8" Crosshole Manifold 3xM10, G1/4	R	OPPOSITE			LL	LOW LEAKAGE
125					EE-D	G1/2, G1/4			B	BLACK	FR	FREE RUNNING
160					EE-M2	M22X1,5 - M14X1,5					LS	LOW SPEED VALVE
200					EE-S2	7/8-14 UNF O-ring, 7/16-20 UNF						
250					ED	11/16-12 UNF O-ring, 7/16-20 UNF						
315					DB	G1/2, G1/4						
375					DU	G1/2, 7/16-20 UNF						
					SB	7/8-14 UNF O-ring, G1/4						
					SU	7/8-14 UNF O-ring 7/16-20 UNF						
					M4	M22X1.5, M14X1.5						
					G	G1/2, G1/4						
					M2	M22X1.5, M14X1.5						
					S2	7/8-14 UNF O-ring 7/16-20 UNF						

**ORDERING CODE:**

All options have been determined with letters, numbers or combinations. All boxes must be filled with proper codes. If specification is not in the table, please contact us with your requirements.

# YMT



The **YMT** series motor incorporates the advanced **GEROLOR** gear set which reduces internal friction to a minimum. A **DISC VALVE** distribution system which is internally balanced to reduce friction, leakage and permits better speed control producing higher efficiency, smoother rotation, higher speeds and pressure.

This series has many sizes and options to make it very flexible for many applications. The output shaft is mounted on tapered roller bearings for high radial and axial loads for very high duty applications.

## SPECIFICATIONS

Distribution Type	Model	Displacement		Max. Operating Pressure		Speed Range Continuous	Max. Output Power	
		[in <sup>3</sup> ./rev]	[9.77~48.82]	[PSI]	[3480]		[HP]	[47]
Disc Distribution	YMT	cm <sup>3</sup> /rev.	160 ~ 800	MPa	24	30~614	Kw	35

## QUICK REFERENCE GUIDE

### YMT SERIES QUICK REFERENCE:

Displacements				
[in. <sup>3</sup> /rev]	cm <sup>3</sup> /rev.			
[9.83]	161.1	FLOW UP TO	125 LPM	[33 GPM]
[12.29]	201.4	PRESSURE UP TO	30 MPa	[4350 PSI]
[14.19]	232.5	TORQUE UP TO	1643 Nm	[14530 lbin.]
[15.36]	251.8	SPEED UP TO	770 RPM	
[19.91]	326.3			
[25.07]	410.9			
[31.95]	523.6			
[38.38]	629.1			
[48.92]	801.8			

**Shaft Seals:** Standard high pressure shaft seals permit applications in series or without drain line when required

**Low Speed Valving:** These motors are manufactured following strict procedures to reduce tolerances between all components to permit lower speed, higher efficiency and smoother rotation at very low speeds. These motors are not for high speed or low pressure applications.

**Free Running:** Motors with this option have increased clearances in the rotor set. This allows improved mechanical efficiency, longer life and better performance for high-speed / high-flow applications, winch or similar applications where the motor is cross-ported to allow manual free turning also remay benefit from this option to allow smoother easier free turning of the motor. Last, applications which have many reversals or high pressure spikes can also benefit since the pressure spikes will be reduced by relieving (cross-porting) such spikes internally in the motor. The trade off of these benefits is a slight reduction in volumetric efficiency, particularly at high pressure conditions.

**Special Motors:** These motors have special options like nickel plated shafts or housings for applications in corrosive environments.

### APPLICATION GUIDELINES:

For optimum results the following working conditions are recommended:

- \* Oil temperature should be between 20° - 60° C [68° - 180° F]
- \* Oil filter of 10 - 20 micron
- \* Oil viscosity 42 - 74 mm<sup>2</sup>/s CSA at 40° C
- \* Different shafts are used when there is a radial load or not. Check data pages
- \* For longer life we suggest the motor at start up run for a shorter period of time (one hour) at no more than 30% of rated speed and pressure.



## SPECIFICATION DATA

DISTRIBUTION TYPE		YMT 160	YMT 200	YMT 250	YMT 315	YMT 400	YMT 500	YMT 630	YMT 800	
GEOMETRIC DISPLACEMENT	[in <sup>3</sup> /rev.]	[9.83]	[12.29]	[15.37]	[19.92]	[25.08]	[31.96]	[38.39]	[48.93]	
	cm <sup>3</sup> /rev.	161.1	201.4	251.8	326.3	410.9	523.6	629.1	801.8	
MAX. SPEED RPM	CONT.	614	615	495	380	302	237	196	154	
	INT.	770	743	592	458	364	284	233	185	
MAX. TORQUE [IN. LB.] N*M	CONT.	[IN. LB.]	[4166]	[5209]	[6430]	[8508]	[9684]	[11,011]	[11,656]	[12,948]
		<b>N*M</b>	<b>471</b>	<b>589</b>	<b>727</b>	<b>962</b>	<b>1095</b>	<b>1245</b>	<b>1318</b>	<b>1464</b>
	INT.	[IN. LB.]	[507]	[6350]	[7853]	[10,206]	[11,223]	[12,461]	[13,248]	[13,443]
		<b>N*M</b>	<b>57.3</b>	<b>718</b>	<b>888</b>	<b>1154</b>	<b>1269</b>	<b>1409</b>	<b>1498</b>	<b>1520</b>
	PEAK	[IN.LB]	[5917]	[7411]	[9162]	[11,907]	[12,826]	[14,538]	[14,317]	[1725]
		<b>N*M</b>	<b>669</b>	<b>838</b>	<b>1036</b>	<b>1346.3</b>	<b>1450.3</b>	<b>1643.8</b>	<b>1618.8</b>	<b>1665</b>
MAX. OUTPUT [HP] KW	CONT.	[HP]	[37.1]	[46.8]	[46.2]	[46.8]	[41.8]	[38.6]	[33.9]	[29.8]
		<b>KW</b>	<b>27.7</b>	<b>34.9</b>	<b>34.5</b>	<b>34.9</b>	<b>31.2</b>	<b>28.8</b>	<b>25.3</b>	<b>22.2</b>
	INT.	[HP]	[42.9]	[53.6]	[53.6]	[53.6]	[46.9]	[46.9]	[36.8]	[35.9]
		<b>KW</b>	<b>32</b>	<b>40</b>	<b>40</b>	<b>40</b>	<b>35</b>	<b>35</b>	<b>27.5</b>	<b>26.8</b>
MAX. PRES- SURE DROP [PSI] MPa	CONT.	[PSI]	[2900]	[2900]	[2900]	[2900]	[2610]	[2320]	[2030]	[1813]
		<b>MPa</b>	<b>20</b>	<b>20</b>	<b>20</b>	<b>20</b>	<b>18</b>	<b>16</b>	<b>14</b>	<b>12.5</b>
	INT.	[PSI]	[3480]	[3480]	[3480]	[3480]	[3045]	[2610]	[2320]	[1885]
		<b>MPa</b>	<b>24</b>	<b>24</b>	<b>24</b>	<b>24</b>	<b>21</b>	<b>18</b>	<b>16</b>	<b>13</b>
	PEAK	[PSI]	[4060]	[4060]	[4060]	[4060]	[3480]	[3045]	[2755]	[2320]
		<b>MPa</b>	<b>28</b>	<b>28</b>	<b>28</b>	<b>28</b>	<b>24</b>	<b>21</b>	<b>19</b>	<b>16</b>
MAX. FLOW [GPM] L/MIN	CONT.	[GPM]	[26.4]	[33]	[33]	[33]	[33]	[33]	[33]	[33]
		<b>L/MIN</b>	<b>100</b>	<b>125</b>	<b>125</b>	<b>125</b>	<b>125</b>	<b>125</b>	<b>125</b>	<b>125</b>
	INT.	[GPM]	[33]	[39.6]	[39.6]	[39.6]	[39.6]	[39.6]	[39.6]	[39.6]
		<b>L/MIN</b>	<b>125</b>	<b>150</b>	<b>150</b>	<b>150</b>	<b>150</b>	<b>150</b>	<b>150</b>	<b>150</b>
MAX. INLET PRESSURE [PSI] MPa	CONT.	[PSI]	[3045]	[3045]	[3045]	[3045]	[3045]	[3045]	[3045]	[3045]
		<b>MPa</b>	<b>21</b>	<b>21</b>	<b>21</b>	<b>21</b>	<b>21</b>	<b>21</b>	<b>21</b>	<b>21</b>
	INT.	[PSI]	[3625]	[3625]	[3625]	[3625]	[3625]	[3625]	[3625]	[3625]
		<b>MPa</b>	<b>25</b>	<b>25</b>	<b>25</b>	<b>25</b>	<b>25</b>	<b>25</b>	<b>25</b>	<b>25</b>
	PEAK	[PSI]	[4350]	[4350]	[4350]	[4350]	[4350]	[4350]	[4350]	[4350]
		<b>MPa</b>	<b>30</b>	<b>30</b>	<b>30</b>	<b>30</b>	<b>30</b>	<b>30</b>	<b>30</b>	<b>30</b>
WEIGHT [LB] KG	[LB]	[43]	[44]	[45]	[46]	[48]	[52]	[53]	[55]	
	<b>KG</b>	<b>19.5</b>	<b>20</b>	<b>20.5</b>	<b>21</b>	<b>22</b>	<b>23</b>	<b>24</b>	<b>25</b>	

\* Continuous pressure:

Max. value of operating motor continuously.

\* Intermittent pressure:

Max. value of operating motor in 6 seconds per minute.

\* Peak pressure:

Max. value of operating motor in 0.6 second per minute.

## PERFORMANCE DATA

YMT 160 [9.83 in<sup>3</sup>./rev.] 161.1 cm<sup>3</sup>/rev.

		[580] 4	[1160] 8	[1450] 10	[1740] 12	[2320] 16	[2900] 20	[3480] 24	[PSI] MPa
GPM	[2.7]	[778]	[1557]	[2016]	[2432]	[3193]	[3953]	[4732]	
	10	88	176	228	275	361	447	535	
L / min	[5.3]	[787]	[1601]	[2070]	[2450]	[3290]	[4059]	[4926]	TORQUE (LB-IN)
	20	89	181	234	277	372	459	557	TORQUE (N•M)
Flow (L/min)	[10.6]	[805]	[1592]	[2079]	[2450]	[3370]	[4166]	[5068]	SPEED (RPM)
	40	91	180	235	277	381	471	573	
Flow (L/min)	[15.9]	[725]	[1574]	[2078]	[2449.79]	[3370]	[4157]	[5059]	
	60	82	178	235	277	381	470	572	
Flow (L/min)	[21.1]	[689.84]	[1530.02]	[2025.28]	[2440.95]	[3351.88]	[4121.31]	[5014.55]	
	80	78	173	229	276	379	466	567	
Max cont.	[26.4]	[619]	[1415]	[1928]	[2379]	[3272]	[4024]	[4935]	Max cont.
	100	70	160	218	269	370	455	558	
Max int.	[33.0]	[513]	[1309]	[1866]	[2308]	[3175]	[3962]	[4882]	Max int.
	125	58	148	211	261	359	448	552	
		<b>770</b>	<b>764</b>	<b>758</b>	<b>750</b>	<b>741</b>	<b>731</b>	<b>715</b>	

YMT 200 [12.29 in<sup>3</sup>./rev.] 201.4 cm<sup>3</sup>/rev.

		[580] 4	[1160] 8	[1450] 10	[1740] 12	[2320] 16	[2900] 20	[3480] 24	[PSI] MPa
GPM	[2.7]	[1097]	[2061]	[2556]	[3007]	[4015]	[4953]	[5917]	
	10	124	233	289	340	454	560	669	
L / min	[5.3]	[1106]	[2114]	[2635.52]	[3069]	[4139]	[5094]	[6155]	TORQUE (LB-IN)
	20	125	239	298	347	468	576	696	TORQUE (N•M)
Flow (L/min)	[10.6]	[1061]	[2131]	[2618]	[3113]	[4201]	[5210]	[6332]	SPEED (RPM)
	40	120	241	296	352	475	589	716	
Flow (L/min)	[15.9]	[1026]	[2096]	[2609]	[3113]	[4227]	[5209]	[6350]	
	60	116	237	295	352	478	589	718	
Flow (L/min)	[21.1]	[955]	[2043]	[2556]	[3095]	[4192]	[5183]	[6332]	
	80	108	231	289	350	474	586	716	
Max cont.	[26.4]	[876]	[2008]	[2529]	[3042]	[4166]	[5130]	[6297]	Max cont.
	100	99	227	286	344	471	580	712	
Max int.	[33.0]	[743]	[1840]	[2441]	[2945]	[4059]	[5006]	[6164]	Max int.
	125	84	208	276	333	459	566	697	
Max int.	[39.6]	[619]	[1716]	[2299]	[2865]	[3953]	[4900]	[6032]	Max int.
	150	70	194	260	324	447	554	682	
		<b>743</b>	<b>740</b>	<b>735</b>	<b>727</b>	<b>717</b>	<b>706</b>	<b>682</b>	

YMT 250 [15.37 in<sup>3</sup>./rev.] 251.8 cm<sup>3</sup>/rev.

		[580] 4	[1160] 8	[1450] 10	[1740] 12	[2320] 16	[2900] 20	[3480] 24	[PSI] MPa
GPM	[2.7]	[1220]	[2529]	[3140]	[3706]	[4944]	[6094]	[7287]	
	10	138	286	355	419	559	689	824	
L / min	[5.3]	[1265]	[2618]	[3219]	[3821]	[5130]	[6262]	[7544]	TORQUE (LB-IN)
	20	143	296	364	432	580	708	853	TORQUE (N•M)
Flow (L/min)	[10.6]	[1229]	[2662]	[3290]	[3891]	[5244]	[6394]	[7818]	SPEED (RPM)
	40	139	301	372	440	593	723	884	
Flow (L/min)	[15.9]	[1167]	[2600]	[3290]	[3900]	[5236]	[6430]	[7853]	
	60	132	294	372	441	592	727	888	
Flow (L/min)	[21.1]	[1132]	[2503]	[3219]	[3829]	[5191]	[6377]	[7845]	
	80	128	283	364	433	587	721	887	
Max cont.	[26.4]	[1114]	[2494]	[3140]	[3776]	[5147]	[6332]	[7774]	Max cont.
	100	126	282	355	427	582	716	879	
Max int.	[33.0]	[1026]	[2299]	[3007]	[3661]	[5023]	[6217]	[7641]	Max int.
	125	116	260	340	414	568	703	864	
Max int.	[39.6]	[778]	[2140]	[2830]	[3511]	[4882]	[6067]	[7491]	Max int.
	150	88	242	320	397	552	686	847	
		<b>592</b>	<b>589</b>	<b>585</b>	<b>580</b>	<b>572</b>	<b>565</b>	<b>545</b>	

YMT 315 [19.92 in<sup>3</sup>./rev.] 326.3 cm<sup>3</sup>/rev.

		[580] 4	[1160] 8	[1450] 10	[1740] 12	[2320] 16	[2900] 20	[3480] 24	[PSI] MPa
GPM	[2.7]	[1627]	[3210]	[4006]	[4820]	[6491]	[7880]	[9392]	
	10	184	363	453	545	734	891	1062	
L / min	[5.3]	[1672]	[3361]	[4174]	[4970]	[6695]	[8110]	[9808]	TORQUE (LB-IN)
	20	189	380	472	562	757	917	1109	TORQUE (N•M)
Flow (L/min)	[10.6]	[1689]	[3370]	[4280]	[5041]	[6845]	[8437]	[10,162]	SPEED (RPM)
	40	191	381	484	570	774	954	1149	
Flow (L/min)	[15.9]	[1672]	[3325]	[4360]	[5068]	[6828]	[8508]	[10,206]	
	60	189	376	493	573	772	962	1154	
Flow (L/min)	[21.1]	[1583]	[3263]	[4236]	[4997]	[6951]	[8437]	[10,197]	
	80	179	369	479	565	786	954	1153	
Max cont.	[26.4]	[1495]	[3157]	[4130]	[4970]	[6704]	[8331]	[10,109]	Max cont.
	100	169	357	467	562	758	942	1143	
Max int.	[33.0]	[1300]	[2972]	[3953]	[4811]	[6589]	[8136]	[9967]	Max int.
	125	147	336	447	544	745	920	1127	
Max int.	[39.6]	[1052]	[2812]	[3821]	[4652]	[6306]	[7907]	[9702]	Max int.
	150	119	318	432	526	713	894	1097	
		<b>458</b>	<b>456</b>	<b>453</b>	<b>449</b>	<b>444</b>	<b>431</b>	<b>425</b>	

## PERFORMANCE DATA

YMT 400 [25.08 in<sup>3</sup>./rev.] 410,9 cm<sup>3</sup>/rev. Max cont. Max int.

		[435] 3	[870] 6	[1305] 9	[1740] 12	[2175] 15	[2610] 18	[3045] 21	[PSI] MPa
GPM	[2.7]	[1557]	[3246]	[4953]	[6323]	[7827]	[9286]	[10,692]	
	10	176	367	560	715	885	1050	1209	
L/ min	[5.3]	[1583]	[3272]	[4997]	[6421]	[7951]	[9472]	[10,931]	TORQUE [LB-IN]
	20	179	370	565	726	899	1071	1236	TORQUE (N•M)
Flow (L/min)	[10.6]	[1557]	[3272]	[5015]	[6483]	[8128]	[9649]	[11,170]	SPEED (RPM)
	40	176	370	567	733	919	1091	1263	
Flow (L/min)	[15.9]	[1539]	[3193]	[4979]	[6447]	[8136]	[9684]	[11,223]	
	60	174	361	563	729	920	1095	1269	
Flow (L/min)	[21.1]	[1468]	[3122]	[4891]	[6359]	[8066]	[9587]	[11,170]	
	80	166	353	553	719	912	1084	1263	
Flow (L/min)	[26.4]	[1327]	[2998]	[4758]	[6262]	[7924]	[9437]	[11,073]	
	100	150	339	538	708	896	1067	1252	
Max cont.	[33.0]	[1194]	[2733]	[4634]	[6085]	[7721]	[9242]	[10,799]	
	125	135	309	524	688	873	1045	1221	Max cont.
Max int.	[39.6]	[1114]	[2582]	[4493]	[5890]	[7535]	[9021]	[10,586]	
	150	126	292	508	666	852	1020	1197	Max int.
		<b>364</b>	<b>362</b>	<b>358</b>	<b>354</b>	<b>350</b>	<b>346</b>	<b>339</b>	

YMT 500 [31.96 in<sup>3</sup>./rev.] 523,6 cm<sup>3</sup>/rev. Max cont. Max int.

		[435] 3	[870] 6	[1305] 9	[1740] 12	[2030] 14	[2320] 16	[2610] 18	[PSI] MPa
GPM	[2.7]	[1963]	[3989]	[6120]	[7889]	[9286]	[10,551]	[11,851]	
	10	222	451	692	892	1050	1193	1340	
L/ min	[5.3]	[2043]	[4104]	[6313]	[8119]	[9463]	[10,790]	[12,178]	TORQUE [LB-IN]
	20	231	464	714	918	1070	1220	1377	TORQUE (N•M)
Flow (L/min)	[10.6]	[2034]	[4121]	[6430]	[8322]	[9675]	[11,002]	[12,576]	SPEED (RPM)
	40	230	466	727	941	1094	1244	1422	
Flow (L/min)	[15.9]	[1990]	[4042]	[6315]	[8322]	[9622]	[11,011]	[12,461]	
	60	225	457	714	941	1088	1245	1409	
Flow (L/min)	[21.1]	[1884]	[3812]	[6155]	[8198]	[9516]	[11,002]	[12,390]	
	80	213	431	696	927	1076	1244	1401	
Flow (L/min)	[26.4]	[1716]	[3714]	[6014]	[7968]	[9401]	[10,825]	[12,231]	
	100	194	420	680	901	1063	1224	1383	
Max cont.	[33.0]	[1610]	[3520]	[5669]	[7756]	[9056]	[10,604]	[11,957]	
	125	182	398	641	877	1024	1199	1352	Max cont.
Max int.	[39.6]	[1300]	[3263]	[5466]	[7544]	[8879]	[10,321]	[11,718]	
	150	147	369	618	853	1004	1167	1325	Max int.
		<b>284</b>	<b>283</b>	<b>282</b>	<b>280</b>	<b>278</b>	<b>276</b>	<b>272</b>	

YMT 630 [38.39 in<sup>3</sup>./rev.] 629,1 cm<sup>3</sup>/rev. Max cont. Max int.

		[435] 3	[870] 6	[1305] 9	[1522] 10.5	[1740] 12	[2030] 14	[2320] 16	[PSI] MPa
GPM	[2.7]	[2061]	[4599]	[7031]	[7977]	[9498]	[10,560]	[12,054]	
	10	233	520	795	902	1074	1194	1363	
L/ min	[5.3]	[2096]	[4900]	[7402]	[8428]	[9879]	[10,958]	[12,444]	TORQUE [LB-IN]
	20	237	554	837	953	1117	1239	1407	TORQUE (N•M)
Flow (L/min)	[10.6]	[2114]	[4891]	[7606]	[8729]	[10,356]	[11,568]	[13,116]	SPEED (RPM)
	40	239	553	860	987	1171	1308	1483	
Flow (L/min)	[15.9]	[1972]	[4811]	[7632]	[8649]	[10,365]	[11,656]	[13,248]	
	60	223	544	863	978	1172	1318	1498	
Flow (L/min)	[21.1]	[1946]	[4749]	[7553]	[8534]	[10,365]	[11,621]	[13,239]	
	80	220	537	854	965	1172	1314	1497	
Flow (L/min)	[26.4]	[1840]	[4617]	[7358]	[8358]	[10,224]	[11,524]	[13,160]	
	100	208	522	832	945	1156	1303	1488	
Max cont.	[33.0]	[1778]	[4413]	[7164]	[8234]	[10,056]	[11,426]	[13,018]	
	125	201	499	810	931	1137	1292	1472	Max cont.
Max int.	[39.6]	[1539]	[4351]	[6943]	[8145]	[9914]	[11,294]	[12,859]	
	150	174	492	785	921	1121	1277	1454	Max int.
		<b>233</b>	<b>232</b>	<b>231</b>	<b>230</b>	<b>227</b>	<b>223</b>	<b>217</b>	

YMT 800 [48.93 in<sup>3</sup>./rev.] 801,8 cm<sup>3</sup>/rev. Max cont. Max int.

		[435] 3	[870] 6	[1305] 9	[1522] 10.5	[1812] 12.5	[1885] 13	[PSI] MPa
GPM	[2.7]	[3060]	[5987]	[8871]	[10,250]	[12,072]	[12,293]	
	10	346	677	1003	1159	1365	1390	
L/ min	[5.3]	[3148]	[6120]	[9145]	[10,462]	[12,417]	[12,895]	TORQUE [LB-IN]
	20	356	692	1034	1183	1404	1458	TORQUE (N•M)
Flow (L/min)	[10.6]	[3228]	[6217]	[9428]	[10,931]	[12,903]	[13,408]	SPEED (RPM)
	40	365	703	1066	1236	1459	1516	
Flow (L/min)	[15.9]	[3131]	[6217]	[9375]	[10,940]	[12,948]	[13,443]	
	60	354	703	1060	1237	1464	1520	
Flow (L/min)	[21.1]	[2936]	[6067]	[9286]	[10,843]	[12,948]	[13,390]	
	80	332	686	1050	1226	1464	1514	
Flow (L/min)	[26.4]	[2697]	[5784]	[9065]	[10,675]	[12,780]	[13,319]	
	100	305	654	1025	1207	1445	1506	
Max cont.	[33.0]	[2476]	[5501]	[8747]	[10,445]	[12,576]	[13,151]	
	125	280	622	989	1181	1422	1487	Max cont.
Max int.	[39.6]	[2184]	[5218]	[8428]	[10,224]	[12,435]	[13,054]	
	150	247	590	953	1156	1406	1476	Max int.
		<b>185</b>	<b>184</b>	<b>183</b>	<b>181</b>	<b>179</b>	<b>172</b>	

## MOUNTING DATA

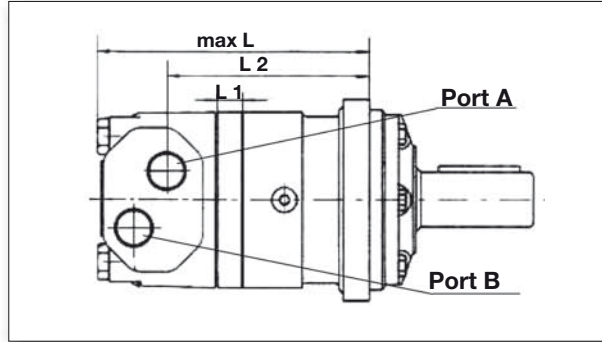
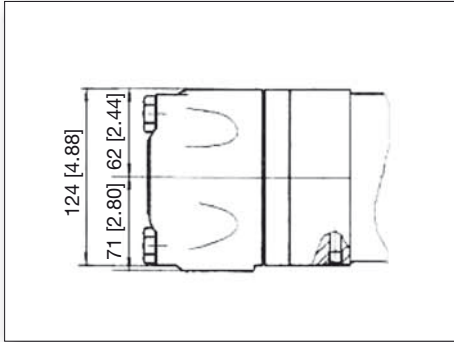

MODEL	[INCHES]		MILLIMETERS	
	L1	L2	L1	L2
YMTW160	[0.67]	[3.03]	17	77
YMTW200	[0.83]	[3.19]	21	81
YMTW250	[1.07]	[3.42]	27	87
YMTW315	[0.79]	[3.58]	20	91
YMTW400	[1.07]	[3.86]	27	98
YMTW500	[1.38]	[4.17]	35	106
YMTW630	[1.85]	[4.64]	47	118
YMTW800	[2.29]	[5.08]	58	129

MODEL	[INCHES]			MILLIMETERS		
	L	L1	L2	L	L1	L2
YMT160	[7.60]	[0.67]	[5.61]	193	17	142.5
YMT200	[7.76]	[0.83]	[5.77]	197	21	146.5
YMT250	[8.00]	[1.07]	[6.01]	203	27	152.5
YMT315	[8.19]	[0.79]	[6.17]	208	20	156.5
YMT400	[8.47]	[1.07]	[6.44]	215	27	163.5
YMT500	[8.78]	[1.38]	[6.76]	223	35	171.5
YMT630	[9.26]	[1.85]	[7.23]	235	47	183.5
YMT800	[9.69]	[2.29]	[7.66]	246	58	194.5

Note: 1) The thickness of the stator and rotor for displacements from 160-250 is the dimension of L1 + 3mm  
 2) The thickness of the stator and rotor for displacements from 315-800 is the dimension of L1 + 7mm.

### PORTS S1,S,G,M3

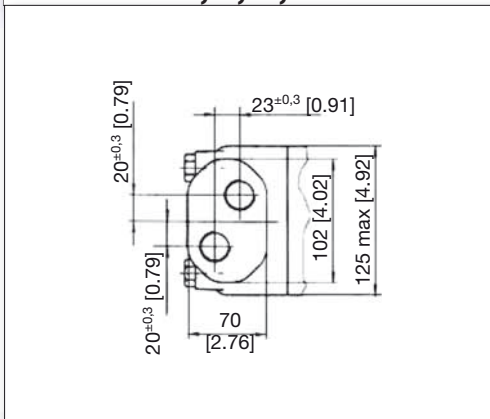

### PORTS D,M

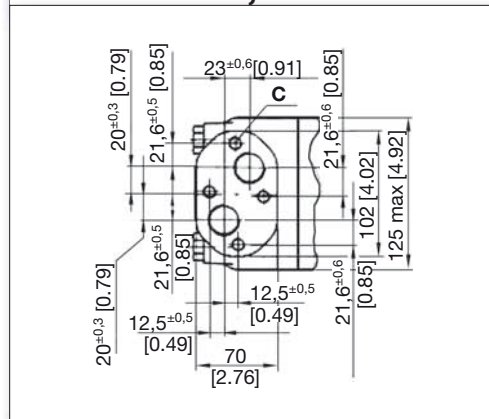

### PORT & DRAIN PORT ORDERING CODES

ORDER CODE	D	DEPTH	M	DEPTH	S	DEPTH	G	DEPTH	M3	DEPTH	S1	DEPTH
PORTS - A and B	G 3/4	18 mm	M27 X 2	18 mm	1-1/16-12 UN	18 mm	G 3/4	18 mm	M27 X 2	18 mm	1-1/16-12 UN	18 MM
TANK PORT - T	G 1/4	12 mm	M14 X1.5	12 mm	9/16-18UNF	12 mm	G 1/4	12 mm	M14X1.5	12MM	7/16-20UNF	12MM
BOLTS - C	4-M10	10 mm	4-M10	10 mm								

## MOUNTING DATA

### FLANGE 4

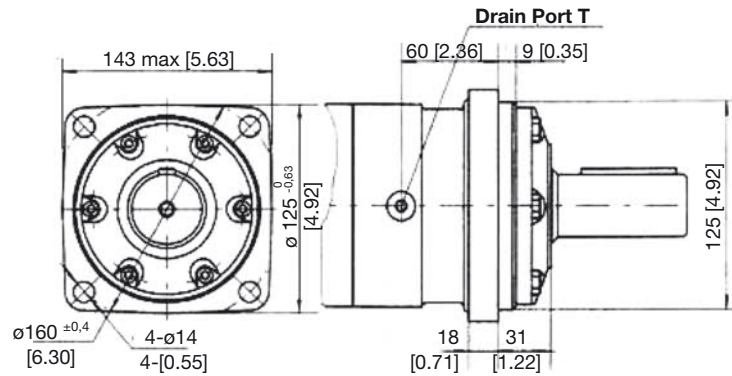

### FLANGE K6

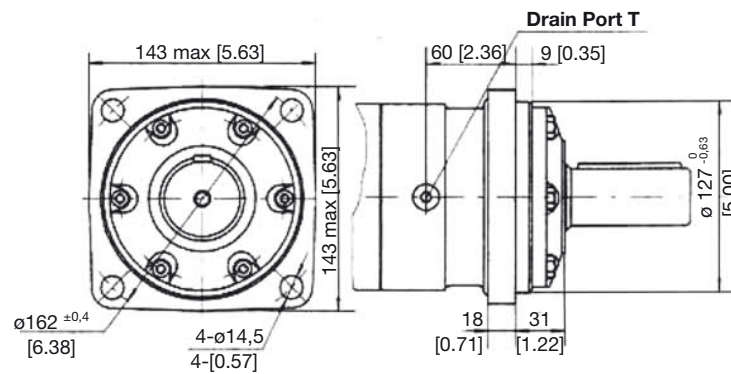

### FLANGE W

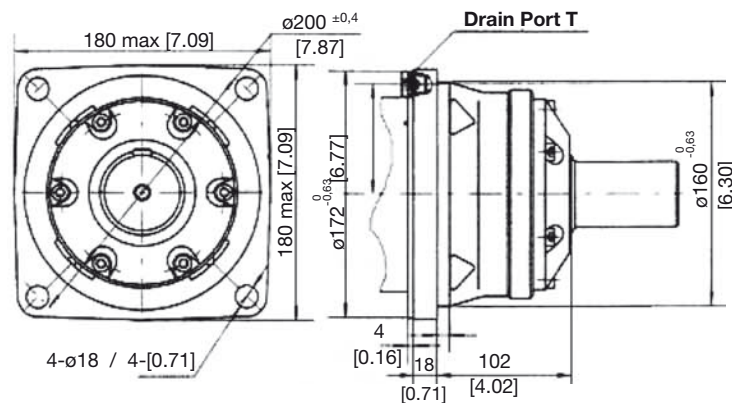

### FLANGE B2E

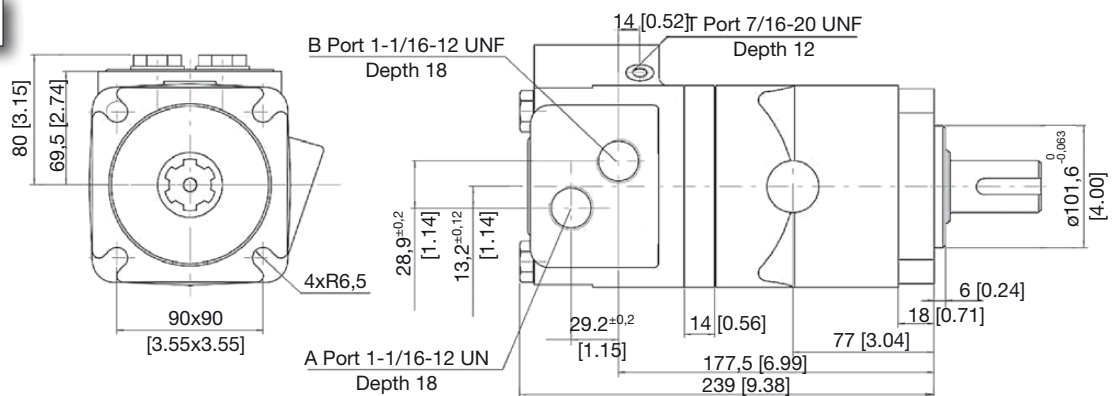

## MOTOR SHAFT EXTENSIONS

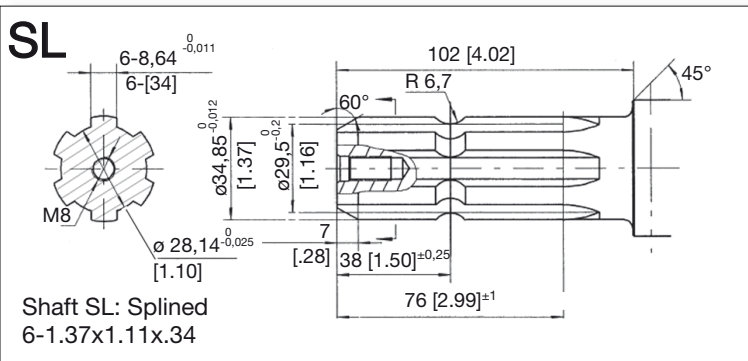
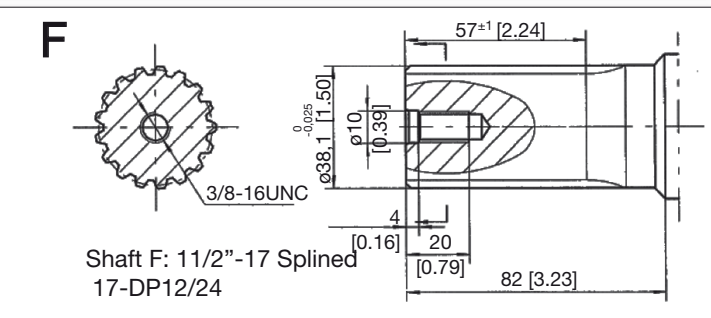
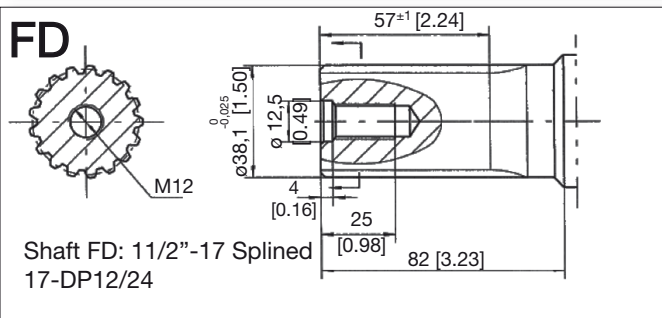
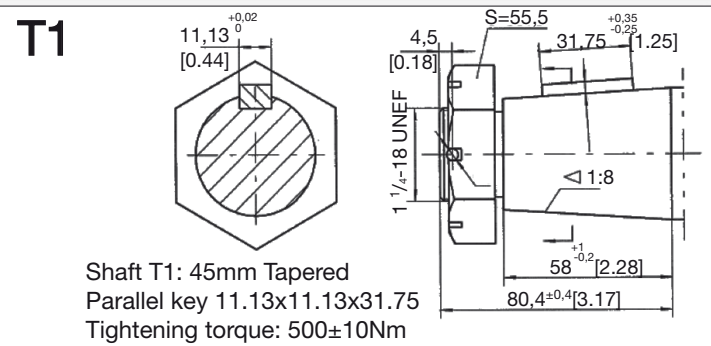
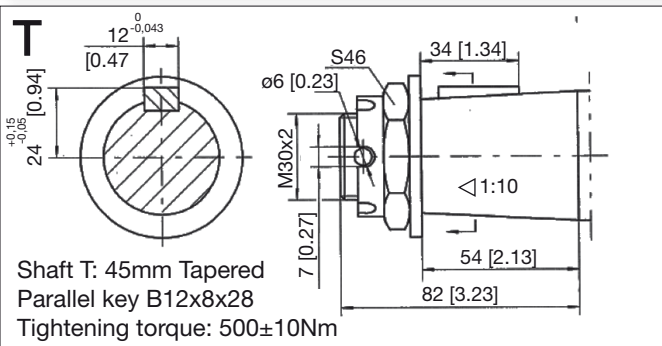
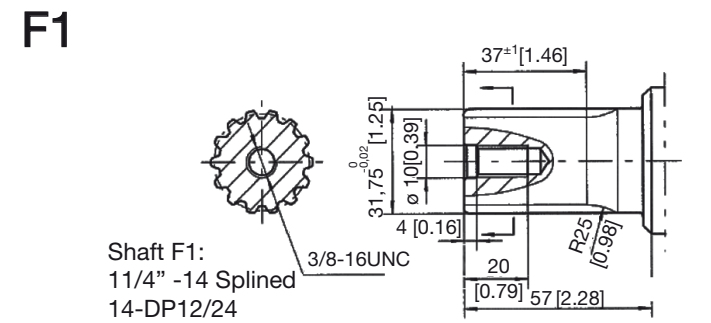
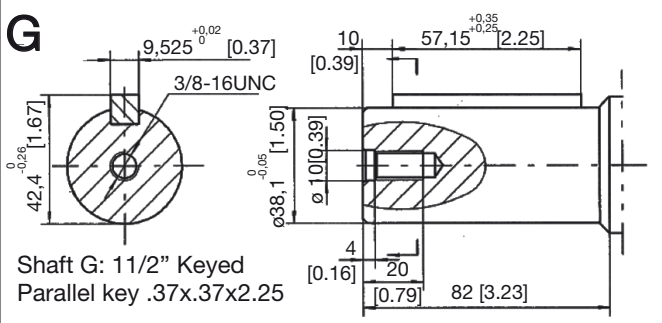
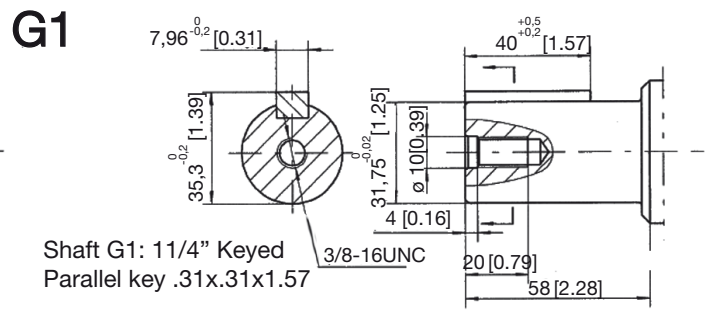
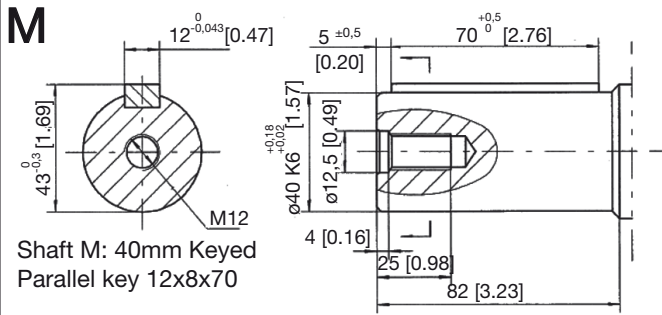

## ADDITIONAL DATA

### PERMISSIBLE SHAFT SEAL PRESSURE

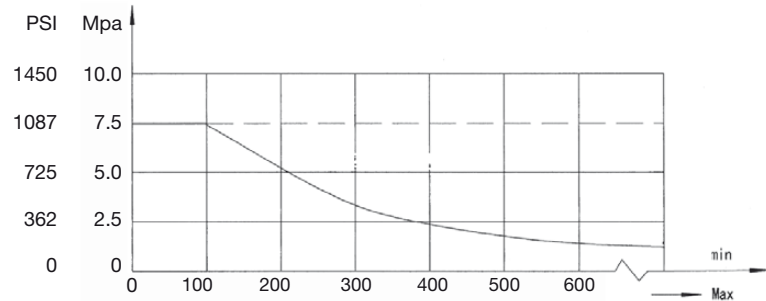
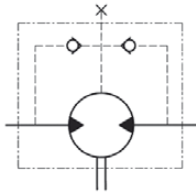

IN APPLICATIONS WITHOUT A DRAIN LINE, THE PRESSURE EXERTED ON THE SHAFT SEAL WILL EXCEED THE PRESSURE IN THE RETURN LINE. IN APPLICATIONS USING A DRAIN LINE, THE PRESSURE ON THE OUTPUT SHAFT SEAL CAN EQUAL THE PRESSURE IN DRAIN LINE.

### DIRECTION OF SHAFT ROTATION

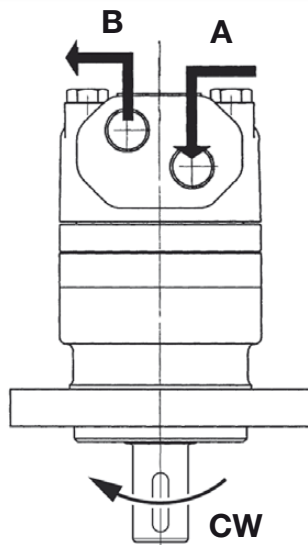

When viewing the motor from the output shaft end, port A is defined to be on the right and port B is defined to be on the left side. Standard rotation motors rotate CW when port A is pressurized. The motors are bi-directional and CCW rotation occurs when port B is pressurized.

Reverse rotation motors can special ordered which will operate with opposite rotation outlined above.

### AXIAL AND RADIAL FORCES

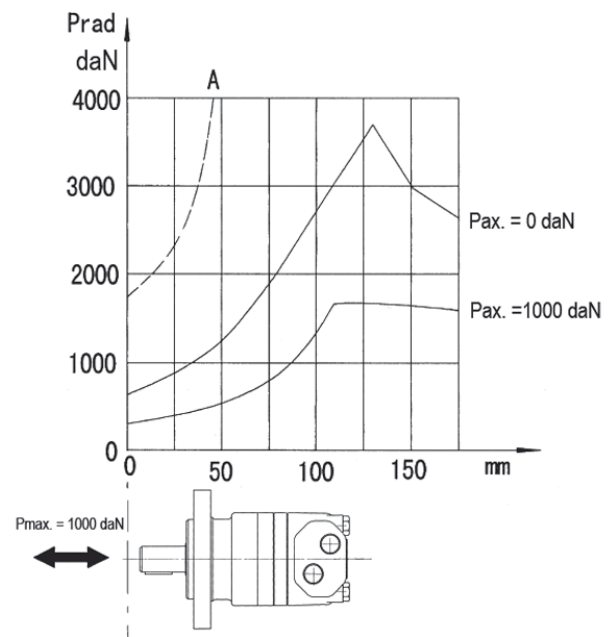

The output shaft is mounted on tapered roller bearings that permit high radial and axial loads. Curve "A" shows Max radial shaft load, Any shaft load exceeding the values quoted in the curve could determine premature failure of the shaft bearings or other parts. The other curves show a B10 life of 3000 hours and 200 RPM.

## ORDERING INFORMATION

	1	2	3	4	5	6	7	8
YMT								

1	2		3		4		5		6		7	
DISP.	FLANGE		OUTPUT SHAFT		PORT AND DRAIN PORT		ROTATION DIRECTION		PAINT		SPECIAL OPTIONS	
160	4	4-Ø14 Square-flange Ø160, pilot Ø125x9	M	Shaft: 40mm Keyed Key 12x8x70	D	G3/4 Manifold Mount 4-M10, G1/4	NONE	STANDARD	00	NO PAINT	NONE	STANDARD
200	K6	4-Ø14.5 Square-flange Ø162, pilot Ø127x9	G	Shaft: 11/2" Keyed parallel Key .38x.38x2.25	M	M27x2 Manifold Mount 4-M10, M14x1.5	R	OPPOSITE			FR	FREE RUNNING
250	W	4-Ø18 Wheel-flange Ø200, pilot Ø160x7	F	Shaft: 11/2"-17, Splined 17-DP12/24	S	1 1/16-12un, 9/16-18unf			B	BLACK		
315	B2E	4-6.5 Square Flange 4" pilot	T	Shaft: 45mm Tapered parallel key B12x28x8	S1	1-1/16-12UN, 7/16- 20UNF					LSV	LOW SPEED VALVE
400			T1	Shaft: 45mm Tapered key 11.13x11.13x31.75	G	G3/4 - G1/4					CRS	CORROSION RESISTANT SHAFT
500			S L	Shaft: Ø34.85, splined 6-34.85x28.14x8.64	M3	M27x2 - M14x1.5					HPS	HIGH PRESSURE SEAL
630			G1	Shaft: 11/4 Keyed parallel key 7.96x7.96x40							HTS	HIGH TEMP SEAL
800			F1	Shaft: 11/4"-14 Splined 14-DP12/24								
			FD	Shaft: 11/2"-17 Splined 17-DP12/24								

### ORDERING CODE:

All options have been determined with letters, numbers or combinations. All boxes must be filled with proper codes. If specification is not in the table, please contact us with your requirements.



# YMTE



The **YMTE** series motor incorporates the advanced **ROLLER** gear set which reduces internal friction to a minimum. A **DISC VALVE** distribution system which is internally balanced to reduce friction, leakage and permit better speed control. Producing efficiency, smoother rotation, higher speed and pressure.

This series has many sizes and options to make it very flexible for many applications. The output shaft is mounted on tapered roller bearings for high radial and axial loads for very high duty applications.

## SPECIFICATIONS

Distribution Type	Model	Displacement		Max. Operating Pressure		Speed Range Continuous	Max. Output Power	
		[in <sup>3</sup> ./rev]	[9.77~48.82]	[PSI]	[3480]		[HP]	[47]
Disc Distribution	YMTE	cm <sup>3</sup> /rev.	160 ~ 800	MPa	24	30~536	Kw	35

## QUICK REFERENCE GUIDE

### YMTE SERIES QUICK REFERENCE:

Displacements				
[in <sup>3</sup> ./rev]	cm <sup>3</sup> /rev.			
[14.19]	232.5	FLOW UP TO	125 LPM	[33 GPM]
[15.36]	251.8	PRESSURE UP TO	30 MPA	[4350 PSI]
[19.91]	326.3	TORQUE UP TO	1643 NM	[14530 LBIN.]
[25.07]	410.9	SPEED UP TO	770 RPM	
[31.95]	523.6			
[38.38]	629.1			
[48.91]	801.8			

**Shaft Seals:** Standard high pressure shaft seals permit applications in series or without drain line when required

**Low Speed Valving:** These motors are manufactured following strict procedures to reduce tolerances between all components to permit lower speed, higher efficiency and smoother rotation at very low speeds. These motors are not for high speed or low pressure applications.

**Free Running:** Motors with this option have increased clearances in the rotor set. This allows improved mechanical efficiency, longer life and better performance for high-speed / high-flow applications, winch or similar applications where the motor is cross-ported to allow manual free turning also may benefit from this option to allow smoother easier free turning of the motor. Last, applications which have many reversals or high pressure spikes can also benefit since the pressure spikes will be reduced by relieving (cross-porting) such spikes internally in the motor. The trade off of these benefits is a slight reduction in volumetric efficiency, particularly at high pressure conditions.

**Special Motors:** These motors have special options like nickel plated shafts or housings for applications in corrosive environments.

### APPLICATION GUIDELINES:

For optimum results the following working conditions are recommended:

- \* Oil temperature should be between 20° - 60° C [68° - 180° F]
- \* Oil filter of 10 - 20 micron
- \* Oil viscosity 42 - 74 mm<sup>2</sup>/s CSA at 40° C
- \* Different shafts are used when there is a radial load or not. Check data pages
- \* For longer life we suggest the motor at start up, run for a shorter period of time (one hour) at no more than 30% of rated speed and pressure.

## SPECIFICATION DATA

- For individual motor performance charts consult equivalent YMT series data

DISTRIBUTION TYPE			YMTE 230	YMTE 250	YMTE 315	YMTE 400	YMTE 500	YMTE 630	YMTE 800
GEOMETRIC DISPLACEMENT	[in <sup>3</sup> /rev.]		[14.19]	[15.37]	[19.92]	[25.08]	[31.96]	[38.39]	[48.93]
	cm <sup>3</sup> /rev.		<b>232.5</b>	<b>251.8</b>	<b>326.3</b>	<b>410.9</b>	<b>523.6</b>	<b>629.1</b>	<b>801.8</b>
MAX. SPEED RPM	CONT.		536	495	380	302	237	196	154
	INT.		<b>643</b>	<b>592</b>	<b>458</b>	<b>364</b>	<b>284</b>	<b>233</b>	<b>185</b>
MAX. TORQUE [IN. LB.] N*M	CONT.	[IN. LB.]	[5925]	[6430]	[8508]	[9684]	[11,011]	[11,656]	[12,948]
		N*M	<b>670</b>	<b>727</b>	<b>962</b>	<b>1095</b>	<b>1245</b>	<b>1318</b>	<b>1464</b>
	INT.	[IN. LB.]	[7261]	[7853]	[10,206]	[11,223]	[12,461]	[13,248]	[13,443]
		N*M	<b>821</b>	<b>888</b>	<b>1154</b>	<b>1269</b>	<b>1409</b>	<b>1498</b>	<b>1520</b>
	PEAK	[IN. LB.]	[8473]	[9162]	[11,907]	[12,826]	[14,538]	[14,317]	[17,250]
		N*M	<b>958</b>	<b>1036</b>	<b>1346.3</b>	<b>1450.3</b>	<b>1643.8</b>	<b>1618.8</b>	<b>1665</b>
MAX. OUTPUT [HP] KW	CONT.	[HP]	[46.5]	[46.2]	[46.8]	[41.8]	[38.6]	[33.9]	[29.8]
		KW	<b>34.7</b>	<b>34.5</b>	<b>34.9</b>	<b>31.2</b>	<b>28.8</b>	<b>25.3</b>	<b>22.2</b>
	INT.	[HP]	[53.6]	[53.6]	[53.6]	[46.9]	[46.9]	[36.8]	[35.9]
		KW	<b>40</b>	<b>40</b>	<b>40</b>	<b>35</b>	<b>35</b>	<b>27.5</b>	<b>26.8</b>
MAX. PRES- SURE DROP [PSI] MPa	CONT.	[PSI]	[2900]	[2900]	[2900]	[2610]	[2320]	[2030]	[1813]
		MPa	<b>20</b>	<b>20</b>	<b>20</b>	<b>18</b>	<b>16</b>	<b>14</b>	<b>12.5</b>
	INT.	[PSI]	[3480]	[3480]	[3480]	[3045]	[2610]	[2320]	[1885]
		MPa	<b>24</b>	<b>24</b>	<b>24</b>	<b>21</b>	<b>18</b>	<b>16</b>	<b>13</b>
	PEAK	[PSI]	[4060]	[4060]	[4060]	[3480]	[3045]	[2755]	[2320]
		MPa	<b>28</b>	<b>28</b>	<b>28</b>	<b>24</b>	<b>21</b>	<b>19</b>	<b>16</b>
MAX. FLOW [GPM] L/MIN	CONT.	[GPM]	[33]	[33]	[33]	[33]	[33]	[33]	[33]
		L/MIN	<b>125</b>	<b>125</b>	<b>125</b>	<b>125</b>	<b>125</b>	<b>125</b>	<b>125</b>
	INT.	[GPM]	[39.6]	[39.6]	[39.6]	[39.6]	[39.6]	[39.6]	[39.6]
		L/MIN	<b>150</b>	<b>150</b>	<b>150</b>	<b>150</b>	<b>150</b>	<b>150</b>	<b>150</b>
MAX. INLET PRESSURE [PSI] MPa	CONT.	[PSI]	[3045]	[3045]	[3045]	[3045]	[3045]	[3045]	[3045]
		MPa	<b>21</b>	<b>21</b>	<b>21</b>	<b>21</b>	<b>21</b>	<b>21</b>	<b>21</b>
	INT.	[PSI]	[3625]	[3625]	[3625]	[3625]	[3625]	[3625]	[3625]
		MPa	<b>25</b>	<b>25</b>	<b>25</b>	<b>25</b>	<b>25</b>	<b>25</b>	<b>25</b>
	PEAK	[PSI]	[4350]	[4350]	[4350]	[4350]	[4350]	[4350]	[4350]
		MPa	<b>30</b>	<b>30</b>	<b>30</b>	<b>30</b>	<b>30</b>	<b>30</b>	<b>30</b>
WEIGHT [LB] KG	[LB]	[45]	[45]	[46]	[48]	[52]	[53]	[55]	
	KG	<b>20.4</b>	<b>20.5</b>	<b>21</b>	<b>22</b>	<b>23</b>	<b>24</b>	<b>25</b>	

\* Continuous pressure:

\* Intermittent pressure:

\* Peak pressure:

Max. value of operating motor continuously.

Max. value of operating motor in 6 seconds per minute.

Max. value of operating motor in 0.6 second per minute.

## PORTING DATA

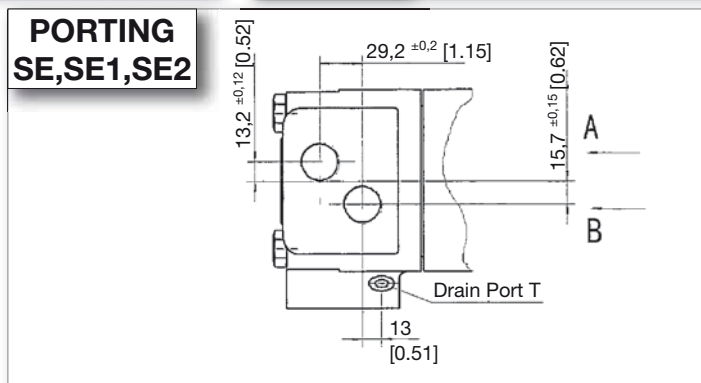
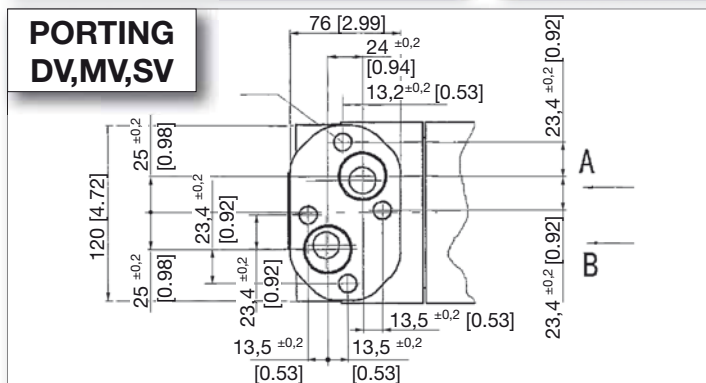
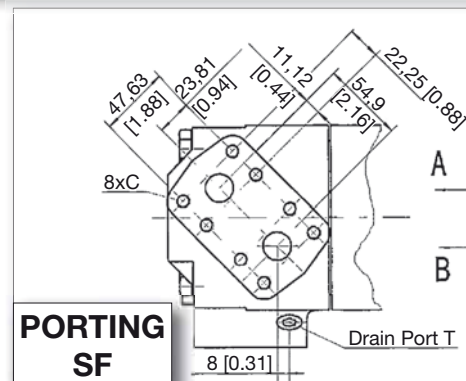
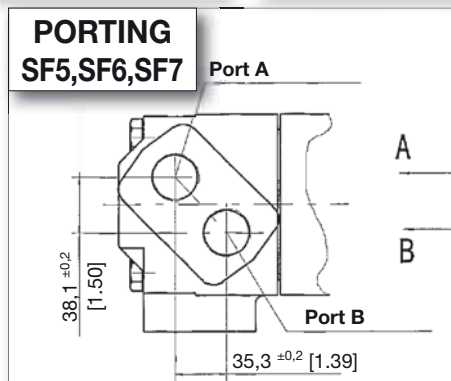
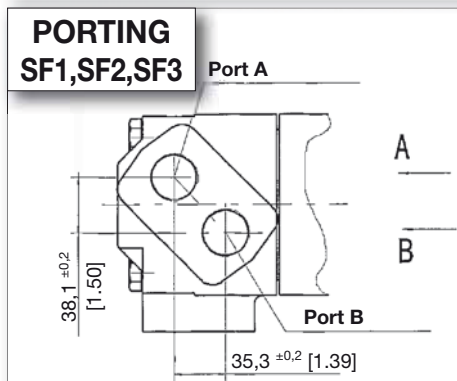
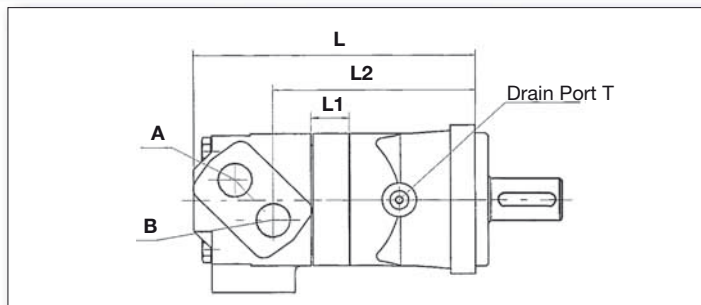
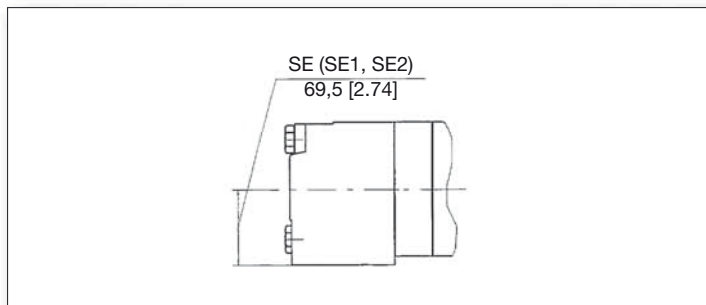

MODEL	[INCHES]			MILLIMETERS		
	L	L1	L2	L	L1	L2
YMTE 230	[9.39]	[0.48]	[6.48]	238.5	12	164.5
YMTE 250	[9.47]	[0.56]	[6.56]	240.5	14	166.5
YMTE 315	[9.71]	[0.79]	[6.80]	246.5	20	172.5
YMTE 400	[9.98]	[1.07]	[7.07]	253.5	27	179.5
YMTE 500	[10.30]	[1.38]	[7.39]	261.5	35	187.5
YMTE 630	[10.77]	[1.85]	[7.86]	273.5	47	199.5
YMTE 800	[11.20]	[2.29]	[8.29]	284.5	58	210.5

Note: 1) The dimensional data for ports SF, SF1 and SF2 are as the chart indicates  
 2) The dimensional data for ports DV, MV and SV are as followed: L dimension-16mm and L2 dimension + 6.5mm.  
 3) The dimensional data for ports SE, SE1, SE2 and WE are as followed: L dimension -70mm and L2 dimension -52mm  
 4) The thickness of the stator and rotor for displacements from 315-800 is the dimension of L1 + 7mm.

ORDER CODE	SF1 SF6	DEPTH	SF2 SF7	DEPTH	SF	DEPTH	DV	DEPTH	MV	DEPTH	SV SF3/SF5	DEPTH	SE	DEPTH	SE1	DEPTH	SE2	DEPTH
PORTS - A and B	M33X2	18 mm	G1	18 mm	3/4"	18 mm	G1	18 mm	M33X2	18 mm	1-5/16-12UN	18 mm	1-1/16-12UN	18 mm	1-1/16-12UN	18 mm	G3/1	18 mm
TANK PORT - T	M14X1.5	12 mm	G 1/4	12 mm	7/16-20UNF	12 mm	G 1/4	12 mm	M14X1.5	12 mm	7/16-20UNF	12 mm	9/16 UNF	12 mm	7/16-20UNF	12 mm	G 1/4	12 mm
BOLTS - C	-	-	-	-	8X3/8-16UNC	-	4XM12	-	4XM12	-	-	-	-	-	-	-	-	-

## MOUNTING FLANGE DATA

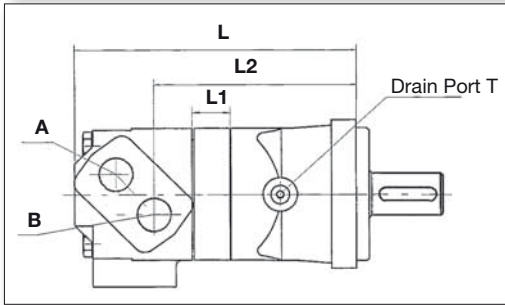

**NOTE:**  
THE THICKNESS  
OF THE STATOR  
AND ROTOR FOR  
DISPLACEMENTS  
315-800 IS THE  
DIMENSION OF  
L1 + 7 MM

MODEL	[INCHES]			MILLIMETERS		
	L	L1	L2	L	L1	L2
YMTE 230	[9.39]	[0.48]	[6.48]	238.5	12	164.5
YMTE 250	[9.47]	[0.56]	[6.56]	240.5	14	166.5
YMTE 315	[9.71]	[0.79]	[6.80]	246.5	20	172.5
YMTE 400	[9.98]	[1.07]	[7.07]	253.5	27	179.
YMTE 500	[10.30]	[1.38]	[7.39]	261.5	35	187.5
YMTE 630	[10.77]	[1.85]	[7.86]	273.5	47	199.5
YMTE 800	[11.20]	[2.29]	[8.29]	284.5	58	210.5

### FLANGE KV

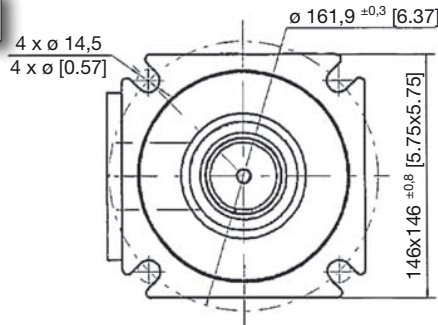

### FLANGE CC

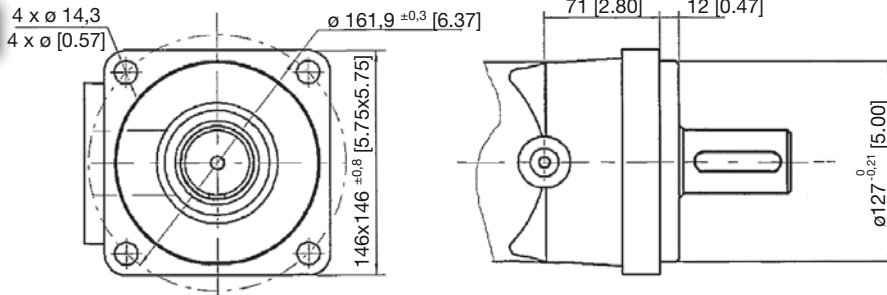

### FLANGE WE

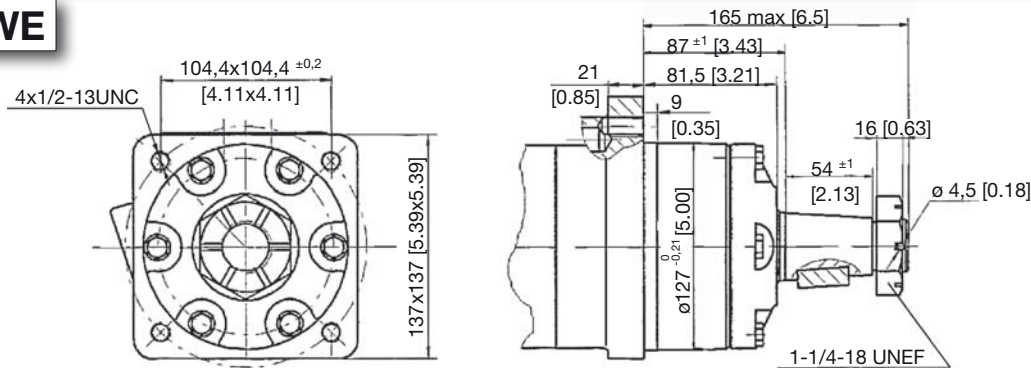

### FLANGE B2E

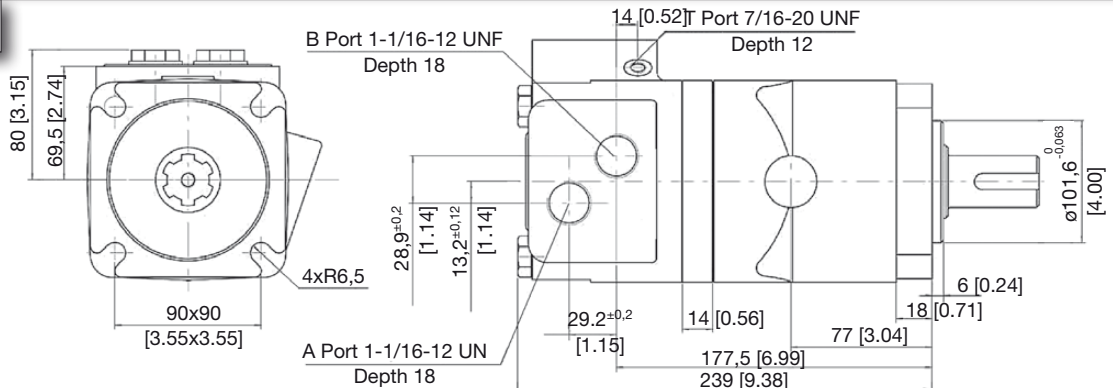

## MOTOR SHAFT EXTENSIONS

**G2**

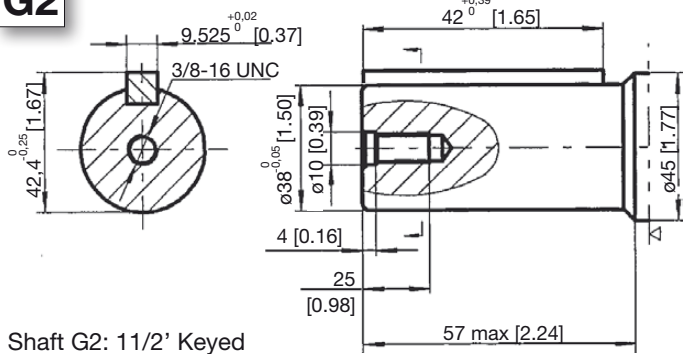

Shaft G2: 11/2' Keyed  
Parallel Key .37x.37x1.65

**FE**

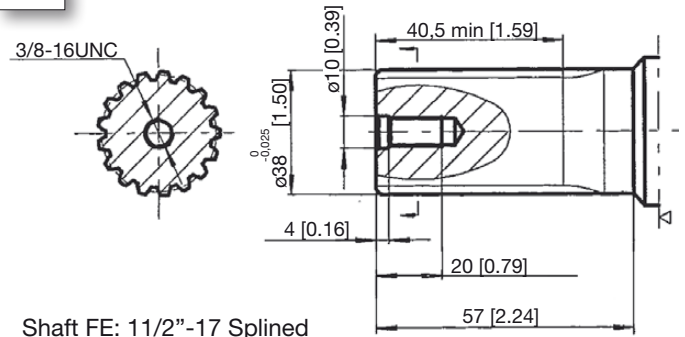

Shaft FE: 11/2''-17 Splined  
17-dp12/24

**Y1**

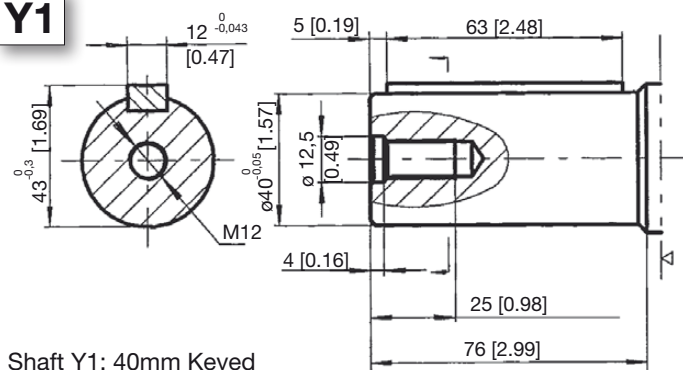

Shaft Y1: 40mm Keyed  
Parallel Key 12x8x63

**Y2**

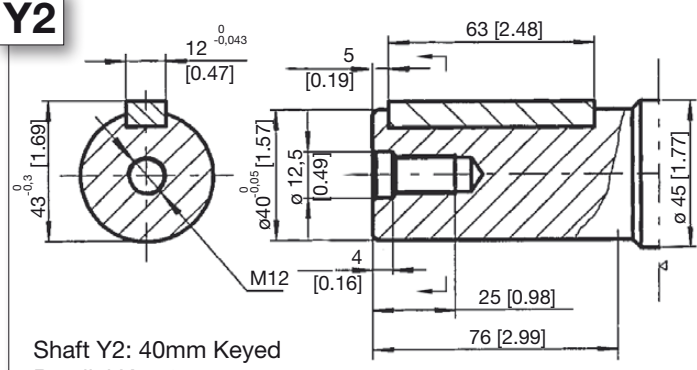

Shaft Y2: 40mm Keyed  
Parallel Key 12x8x63

**T2**

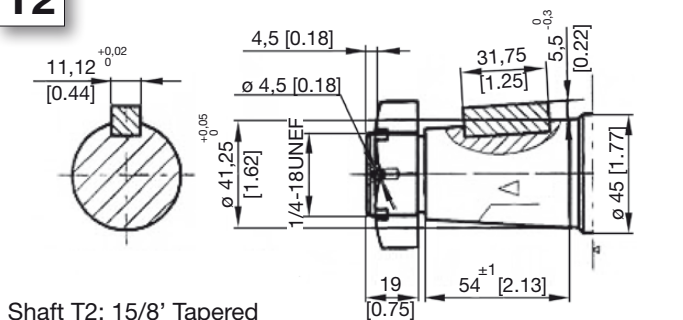

Shaft T2: 15/8' Tapered  
Parallel Key .44x.44x1.25  
Tightening torque: 500±10Nm

**H**

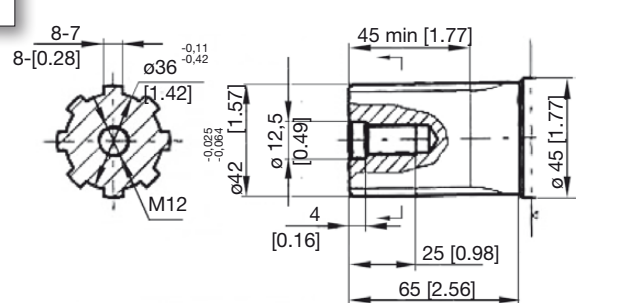

Shaft H: 42mm Splined  
Splines 8-42x36x7

**P**

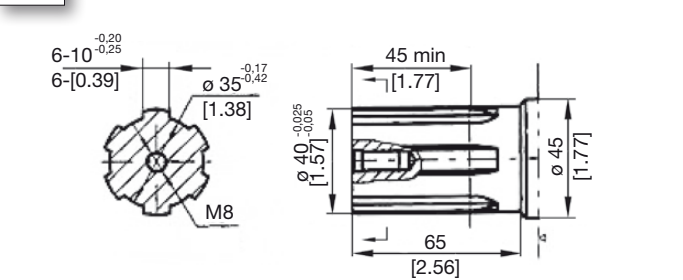

Shaft P: 40mm Splined  
Splines 6-40x35x10

## ADDITIONAL DATA

### PERMISSIBLE SHAFT SEAL PRESSURE

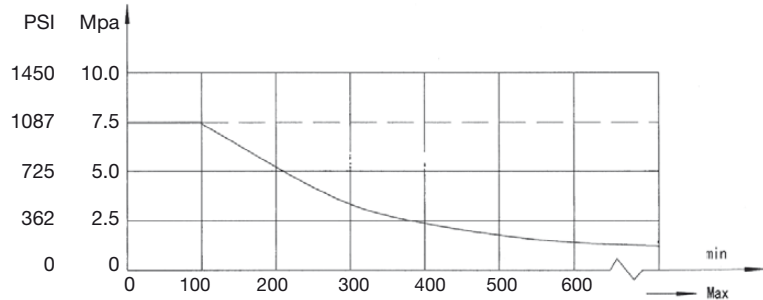
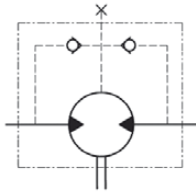

IN APPLICATIONS WITHOUT A DRAIN LINE, THE PRESSURE EXERTED ON THE SHAFT SEAL WILL EXCEED THE PRESSURE IN THE RETURN LINE.  
 IN APPLICATIONS USING A DRAIN LINE, THE PRESSURE ON THE OUTPUT SHAFT SEAL CAN EQUAL THE PRESSURE IN DRAIN LINE.

### DIRECTION OF SHAFT ROTATION

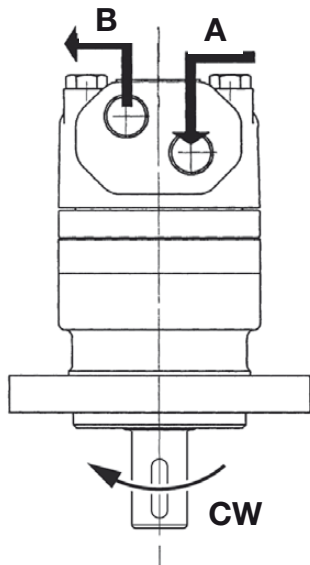

When viewing the motor from the output shaft end, port A is defined to be on the right and port B is defined to be on the left side. Standard rotation motors rotate CW when port A is pressurized. The motors are bi-directional and CCW rotation occurs when port B is pressurized.

Reverse rotation motors can special ordered which will operate with opposite rotation outlined above.

### AXIAL AND RADIAL FORCE

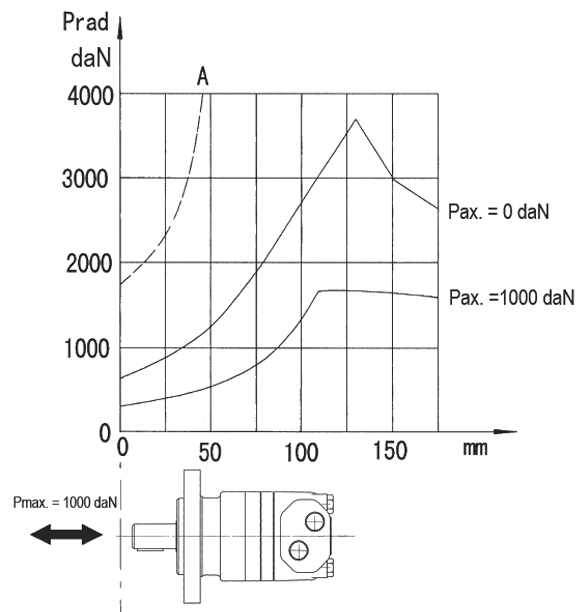

The output shaft is mounted on tapered roller bearings that permit high radial and axial loads. Curve "A" shows MAX radial shaft loads, Any shaft load exceeding the values quoted in the curve could determine premature failure of the shaft, bearings or other parts. The other curves show a B10 life of 3000 Hours and 200 RPM.

## ORDERING INFORMATION

	1	2	3	4	5	6	7
YMTE							

1	2		3		4		5		6		7	
DISP.	FLANGE		OUTPUT SHAFT		PORT AND DRAIN PORT		ROTATION DIRECTION		PAINT		SPECIAL OPTIONS	
230	CC	4-Ø14.3 Square-flange Ø161.9 pilot Ø127X12	G2	11/2" KEYED PARALLEL KEY .37X.37X1.65	SF	3/4' MANIFOLD MOUNT, 8-3/8-16UNC 7/16-20UNF	NONE	STANDARD	00	NO PAINT	NONE	STANDARD
250	KV	4-Ø14.5 Square flange Ø161.9 Ø127x9	FE	11/2"-17 SPLINED 17-DP 12/24	SF1	M33 X 2, M14 X 1.5	R	OPPOSITE			FR	FREE RUNNING
315	WE	4-Ø18 Wheel-flange Ø 147, pilot Ø 127x9	Y1	40MM KEYED PARALLEL KEY 12X8X63	SF2	G1,G1/4			B	BLACK		
400	B2E	4-6.5 Square Flange 101.6 [4.00] Pilot	Y2	40MM KEYED PARALLEL KEY 12X8X63	SE	1-1/16-12UNF O-ring 9/16-18 UNF					LSV	LOW SPEED VALVE
500			T2	15/8" TAPERED PARALLEL KEY .44X.44X1.25	SE1	1-1/16-12UNF O-ring 7/16-20UNF					CRS	CORROSION RESISTANT SHAFT
630			H	42MM SPLINED 8-42X36X7	SE2	G3/4, G1/4					HPS	HIGH PRESSURE SEAL
800			P	40MM SPLINED 6-40X35X10	DV	G1,MANIFOLD MOUNT 4-M12, G1/4					HTS	HIGH TEMP SEAL
			F	1-1/2" - 17 TOOTH SPLINED	MV	M33X2, MANIFOLD MOUNT, 4-M12,M14X1.5						
			G1	1-1/4" KEYED SHAFT	SV	1-5/16-12UNF 7/16-20UNF						
			F1	1-1/4" - 14 TOOTH SPLINED	SF3	1-5/16-12UNF 7/16-20UNF						
					SF5	1-5/16-12 O-ring 7/16-20UNF on rear cover						
					SF6	M33x2, M14x1.5						
					SF7	G1, G 1/4 Drain on rear cover						

**ORDERING CODE:**

All options have been determined with letters, numbers or combinations. All boxes must be filled with proper codes. If specification is not in the table, please contact us with your requirements.



# YMTS



The **YMTS** series motor incorporates the advanced **GEROLOR** gear set which reduces internal friction to a minimum and a **DISC VALVE** distribution system which is internally balanced to reduce friction, leakage and permit better speed control producing higher efficiency, smoother rotation, higher speed and pressure.

This series has many sizes and options to make it very flexible for many applicaton.

## SPECIFICATIONS

Distribution Type	Model	Displacement		Max. Operating Pressure		Speed Range Continuous	Max. Output Power	
		[in <sup>3</sup> ./rev]	[9.77~48.82]	[PSI]	[3480]		[HP]	[47]
DISC Distribution	YMTS	cm <sup>3</sup> /rev.	160 ~ 800	MPa	24	30~614	Kw	35

## QUICK REFERENCE GUIDE

### YMTS SERIES QUICK REFERENCE:

DISPLACEMENTS				
[IN <sup>3</sup> ./REV]	CM <sup>3</sup> /REV.			
[9.83]	161.1	FLOW UP TO	125 LPM	[33.03 GPM]
[12.29]	201.4	PRESSURE UP TO	30 MPA	[4350 PSI]
[14.19]	232.5	TORQUE UP TO	1643 NM	[14530 LBIN.]
[15.36]	251.8	SPEED UP TO	770 RPM	
[19.91]	326.3			
[25.07]	410.9			
[31.95]	523.6			
[38.38]	629.1			
[48.92]	801.8			

**Shaft Seals:** Standard high pressure shaft seals permit applications in series or without drain line when required

**Low Speed Valving:** These motors are manufactured following strict procedures to reduce tolerances between all components to permit lower speed, higher efficiency and smoother rotation at very low speeds. These motors are not for high speed or low pressure applications.

**Free Running:** Motors with this option have increased clearances in the rotor set. This allows improved mechanical efficiency, longer life and better performance for high-speed / high-flow applications, winch or similar applications where the motor is cross-ported to allow manual free turning also remay benefit from this option to allow smoother easier free turning of the motor. Last, applications which have many reversals or high pressure spikes can also benefit since the pressure spikes will be reduced by relieving (cross-porting) such spikes internally in the motor. The trade off of these benefits is a slight reduction in volumetric efficiency, particularly at high pressure conditions.

**Special Motors:** These motors have special options like nickel plated shafts or housings for applications in corrosive environments.

### APPLICATION GUIDELINES:

For optimum results the following working conditions are recommended:

- \* Oil temperature should be between 20° - 60° C [68° - 180° F]
- \* Oil filter of 10 - 20 micron
- \* Oil viscosity 42 - 74 mm<sup>2</sup>/s CSA at 40° C
- \* For longer life we suggest the motor at start up, run for a shorter period of time (one hour) at no more than 30% of rated speed and pressure.

## SPECIFICATION DATA

- For individual motor performance charts consult equivalent YMT series data

DISTRIBUTION TYPE		YMTS 160	YMTS 200	YMTS 230	YMTS 250	YMTS 315	YMTS 400	YMTS 500	YMTS 630	YMTS 800	
GEOMETRIC DISPLACEMENT	[in <sup>3</sup> ./rev.]	[9.83]	[12.29]	[14.19]	[15.37]	[19.92]	[25.08]	[31.96]	[38.39]	[48.93]	
	cm <sup>3</sup> /rev.	<b>161.1</b>	<b>201.4</b>	<b>232.5</b>	<b>251.8</b>	<b>326.3</b>	<b>410.9</b>	<b>523.6</b>	<b>629.1</b>	<b>801.8</b>	
MAX. SPEED RPM	CONT.	614	615	536	495	380	302	237	196	154	
	INT.	<b>770</b>	<b>743</b>	<b>643</b>	<b>592</b>	<b>458</b>	<b>364</b>	<b>284</b>	<b>233</b>	<b>185</b>	
MAX. TORQUE [IN. LB.] N*M	CONT.	[IN. LB.]	[4166]	[5209]	[5925]	[6430]	[8508]	[9684]	[11,011]	[11,656]	[12,948]
		<b>N*M</b>	<b>471</b>	<b>589</b>	<b>670</b>	<b>727</b>	<b>962</b>	<b>1095</b>	<b>1245</b>	<b>1318</b>	<b>1464</b>
	INT.	[IN. LB.]	[507]	[6350]	[7261]	[7853]	[10,206]	[11,223]	[12,461]	[13,248]	[13,443]
		<b>N*M</b>	<b>57.3</b>	<b>718</b>	<b>821</b>	<b>888</b>	<b>1154</b>	<b>1269</b>	<b>1409</b>	<b>1498</b>	<b>1520</b>
	PEAK	[IN. LB.]	[5917]	[7411]	[8473]	[9162]	[11,907]	[12,826]	[14,538]	[14,317]	[1725]
		<b>N*M</b>	<b>669</b>	<b>838</b>	<b>958</b>	<b>1036</b>	<b>1346.3</b>	<b>1450.3</b>	<b>1643.8</b>	<b>1618.8</b>	<b>1665</b>
MAX. OUTPUT [HP] KW	CONT.	[HP]	[37.1]	[46.8]	[46.5]	[46.2]	[46.8]	[41.8]	[38.6]	[33.9]	[29.8]
		<b>KW</b>	<b>27.7</b>	<b>34.9</b>	<b>34.7</b>	<b>34.5</b>	<b>34.9</b>	<b>31.2</b>	<b>28.8</b>	<b>25.3</b>	<b>22.2</b>
	INT.	[HP]	[42.9]	[53.6]	[53.6]	[53.6]	[53.6]	[46.9]	[46.9]	[36.8]	[35.9]
		<b>KW</b>	<b>32</b>	<b>40</b>	<b>40</b>	<b>40</b>	<b>40</b>	<b>35</b>	<b>35</b>	<b>27.5</b>	<b>26.8</b>
MAX. PRES-SURE DROP [PSI] MPa	CONT.	[PSI]	[2900]	[2900]	[2900]	[2900]	[2900]	[2610]	[2320]	[2030]	[1813]
		<b>MPa</b>	<b>20</b>	<b>20</b>	<b>20</b>	<b>20</b>	<b>20</b>	<b>18</b>	<b>16</b>	<b>14</b>	<b>12.5</b>
	INT.	[PSI]	[3480]	[3480]	[3480]	[3480]	[3480]	[3045]	[2610]	[2320]	[1885]
		<b>MPa</b>	<b>24</b>	<b>24</b>	<b>24</b>	<b>24</b>	<b>24</b>	<b>21</b>	<b>18</b>	<b>16</b>	<b>13</b>
	PEAK	[PSI]	[4060]	[4060]	[4060]	[4060]	[4060]	[3480]	[3045]	[2755]	[2320]
		<b>MPa</b>	<b>28</b>	<b>28</b>	<b>28</b>	<b>28</b>	<b>28</b>	<b>24</b>	<b>21</b>	<b>19</b>	<b>16</b>
MAX. FLOW [GPM] L/MIN	CONT.	[GPM]	[26.4]	[33]	[33]	[33]	[33]	[33]	[33]	[33]	[33]
		<b>L/MIN</b>	<b>100</b>	<b>125</b>	<b>125</b>	<b>125</b>	<b>125</b>	<b>125</b>	<b>125</b>	<b>125</b>	<b>125</b>
	INT.	[GPM]	[33]	[39.6]	[39.6]	[39.6]	[39.6]	[39.6]	[39.6]	[39.6]	[39.6]
		<b>L/MIN</b>	<b>125</b>	<b>150</b>	<b>150</b>	<b>150</b>	<b>150</b>	<b>150</b>	<b>150</b>	<b>150</b>	<b>150</b>
MAX. INLET PRESSURE [PSI] MPa	CONT.	[PSI]	[3045]	[3045]	[3045]	[3045]	[3045]	[3045]	[3045]	[3045]	[3045]
		<b>MPa</b>	<b>21</b>	<b>21</b>	<b>21</b>	<b>21</b>	<b>21</b>	<b>21</b>	<b>21</b>	<b>21</b>	<b>21</b>
	INT.	[PSI]	[3625]	[3625]	[3625]	[3625]	[3625]	[3625]	[3625]	[3625]	[3625]
		<b>MPa</b>	<b>25</b>	<b>25</b>	<b>25</b>	<b>25</b>	<b>25</b>	<b>25</b>	<b>25</b>	<b>25</b>	<b>25</b>
	PEAK	[PSI]	[4350]	[4350]	[4350]	[4350]	[4350]	[4350]	[4350]	[4350]	[4350]
		<b>MPa</b>	<b>30</b>	<b>30</b>	<b>30</b>	<b>30</b>	<b>30</b>	<b>30</b>	<b>30</b>	<b>30</b>	<b>30</b>
WEIGHT [LB] KG	[LB]	[43]	[44]	[45]	[45]	[46]	[48]	[52]	[53]	[55]	
	<b>KG</b>	<b>19.5</b>	<b>20</b>	<b>20.4</b>	<b>20.5</b>	<b>21</b>	<b>22</b>	<b>23</b>	<b>24</b>	<b>25</b>	

- \* Continuous pressure:
- \* Intermittent pressure:
- \* Peak pressure:

Max. value of operating motor continuously.  
 Max. value of operating motor in 6 seconds per minute.  
 Max. value of operating motor in 0.6 second per minute.

## DIMENSION AND MOUNTING DATA

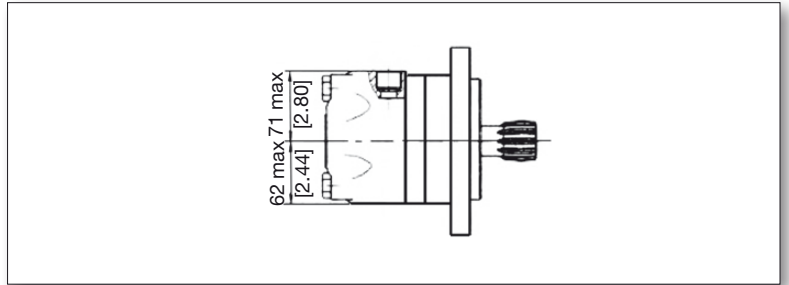
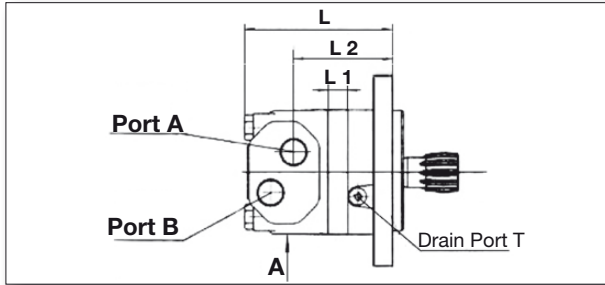

MODEL	[INCHES]			MILLIMETERS		
	L	L1	L2	L	L1	L2
YMTS 160	[5.83]	[0.67]	[3.80]	148	17	96.5
YMTS 200	[5.98]	[0.83]	[3.96]	152	21	100.5
YMTS 250	[6.22]	[1.06]	[4.23]	158	27	107.5
YMTS 315	[6.42]	[0.79]	[4.53]	163	20	115
YMTS 400	6.69]	[1.06]	[4.80]	170	27	122
YMTS 500	[7.01]	[1.38]	[5.12]	178	35	130
YMTS 630	[7.48]	[1.85]	[5.59]	190	47	142
YMTS 800	[7.91]	[2.28]	[6.02]	201	58	153

Note: 1)The thickness of the stator and rotor for displacements from 160-250 is the dimension of L1 + 3mm  
2)The thickness of the stator and rotor for displacements from 315-800 is the dimension of L1 + 7mm.

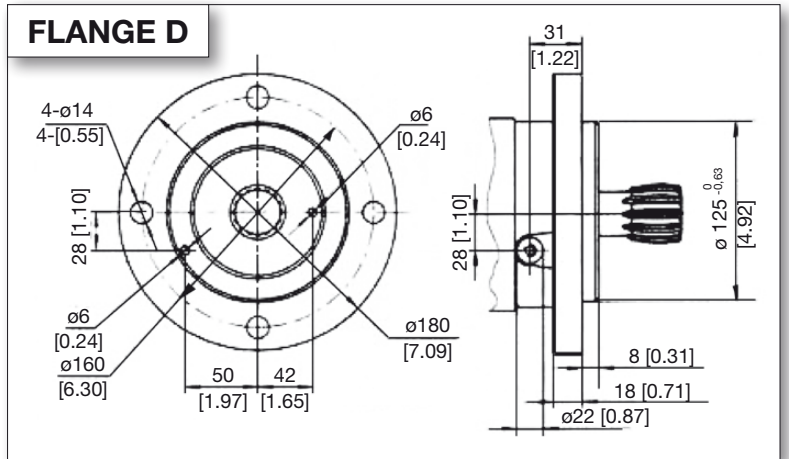

### PORTS S1,S,G2,M3

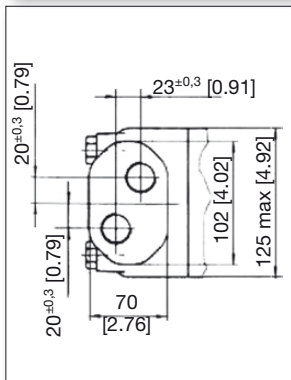

### PORTS D,M

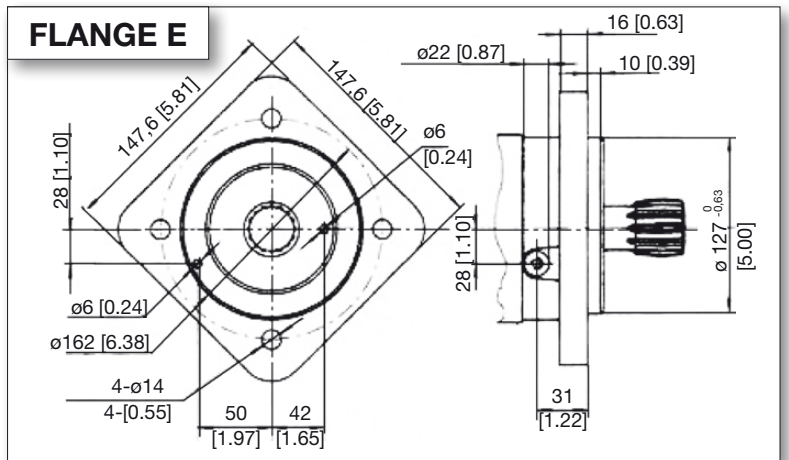
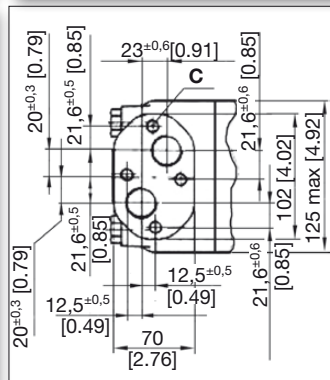

### PORT & DRAIN PORT ORDERING CODES

ORDER CODE	D	DEPTH	M	DEPTH	S	DEPTH	G	DEPTH	M3	DEPTH	S1	DEPTH
PORTS - A and B	G 3/4	18 mm	M27 X 2	18 mm	1-1/16-12 UN	18 mm	G 3/4	18 mm	M27 X 2	18 mm	1-1/16-12 UN	18 MM
TANK PORT - T	G 1/4	12 mm	M14 X1.5	12 mm	9/16-18UNF	12 mm	G 1/4	12 mm	M14X1.5	12 mm	7/16-20UNF	12MM
BOLTS - C	4-M10	10 mm	4-M10	10 mm								

## MOUNTING DATA

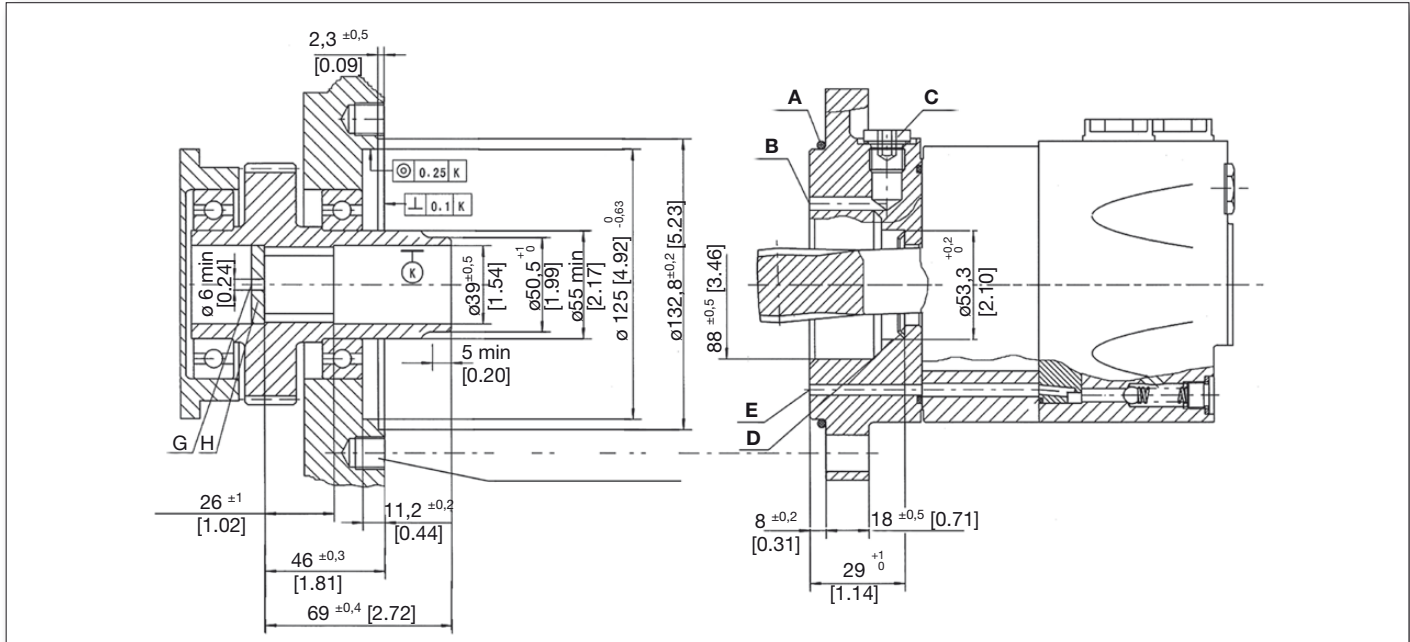

- A: O-ring:125x3
- B: External drain channel
- C: Drain connection G 1/4;12 mm deep
- D: Conical seal ring
- E: Internal drain channel
- F: M12;min. 18mm deep
- G: Oil circulation hole
- H: Hardened stop plate

### INTERNAL SPLINE DATA FOR THE ATTACHED COMPONENT

FILLET ROOT SIDE FIT		mm
NUMBER OF TEETH	Z	16
DIAMETRAL PITCH	DP	12/24
PRESSURE ANGLE	$\alpha_D$	30°
PITCH DIA.	D	Ø33.8656
MAJOR DIA.	$D_{Ei}$	Ø38.4
MINOR DIA.	$D_{Ii}$	Ø32.15
SPACE WIDTH CIRCULAR	E	4.516 ±0.037

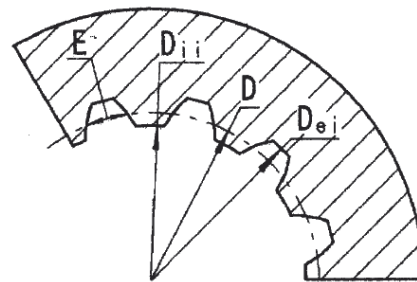

Hardening Specification: HRC 62±2  
Effective case depth 0.7±0.2

## ORDERING INFORMATION

	1	2	3	4	5	6	7
YMTS							

1	2	3	4	5	6	7
DISP.	FLANGE	OUTPUT SHAFT	PORT AND DRAIN PORT	ROTATION DIRECTION	PAINT	SPECIAL OPTIONS
160	D 4-Ø14 Circle-flange Ø160, pilot Ø125x8	NONE Short shaft DP12/24	D G3/4 Manifold Mount 4-M10, G1/4	NONE STANDARD	00 NO PAINT	NONE STANDARD
200			M M27x2 Manifold Mount 4-M10, M14x1.5			FR FREE RUNNING
250	E 4-Ø14.5 Square-flange Ø162, pilot Ø127x10		S 17/16-12 O-ring, 9/16- 18UNF	R REVERSE	B BLACK	LL LOW LEAKAGE
315			S1 1-1/16-12 O-ring, 7/16- 20UNF			LSV LOW SPEED VALVE
400			G G3/4 - G1/4			
500			M3 M27X2, M14X1.5			
630						
800						

### ORDERING CODE:

All options have been determined with letters, numbers or combinations. All boxes must be filled with proper codes. If specification is not in the table, please contact us with your requirements.

# YMTJ

The **YMTJ** series motor incorporates the advanced **GEROLOR** gear set which reduces internal friction to a minimum. A **DISC VALVE** distribution system which is internally balanced to reduce friction, leakage and permits better speed control producing higher efficiency, smoother rotation, higher speed and pressure.

This series has many sizes and options to make it very flexible for many applications.

## SPECIFICATIONS

Distribution Type	Model	Displacement		Max. Operating Pressure		Speed Range Continuous	Max. Output Power	
		[in <sup>3</sup> ./rev]	[14.03 ~48.82]	[PSI]	[3480]		[HP]	[47]
Disc Distribution	YMTJ	cm <sup>3</sup> /rev.	160 ~ 800	MPa	24	30~614	Kw	35

## QUICK REFERENCE GUIDE

### YMTJ SERIES QUICK REFERENCE:

Displacements				
[in <sup>3</sup> ./rev]	cm <sup>3</sup> /rev.			
[14.19]	232.5	FLOW UP TO	125 LPM	[33 GPM]
[15.36]	251.8	PRESSURE UP TO	30 MPA	[4350 PSI]
[19.91]	326.3	TORQUE UP TO	1643 NM	[14530 LBIN.]
[25.07]	410.9	SPEED UP TO	770 RPM	
[31.95]	523.6			
[38.38]	629.1			
[48.84]	801.8			

**Shaft Seals:** Standard high pressure shaft seals permit applications in series or without drain line when required

**Low Speed Valving:** These motors are manufactured following strict procedures to reduce tolerances between all components to permit lower speed, higher efficiency and smoother rotation at very low speeds. These motors are not for high speed or low pressure applications.

**Free Running:** Motors with this option have increased clearances in the rotor set. This allows improved mechanical efficiency, longer life and better performance for high-speed / high-flow applications, winch or similar applications where the motor is cross-ported to allow manual free turning also remay benefit from this option to allow smoother easier free turning of the motor. Last, applications which have many reversals or high pressure spikes can also benefit since the pressure spikes will be reduced by relieving (cross-porting) such spikes internally in the motor. The trade off of these benefits is a slight reduction in volumetric efficiency, particularly at high pressure conditions.

**Special Motors:** These motors have special options like nickel plated shafts or housings for applications in corrosive environments.

### APPLICATION GUIDELINES:

For optimum results the following working conditions are recommended:

- \* Oil temperature should be between 20° - 60° C [68° - 180° F]
- \* Oil filter of 10 - 20 micron
- \* Oil viscosity 42 - 74 mm<sup>2</sup>/s CSA at 40° C
- \* For longer life we suggest the motor at start, run for a shorter period of time (one hour) at no more than 30% of rated speed and pressure.



## SPECIFICATION DATA

- For individual motor performance charts consult equivalent YMT series data

DISTRIBUTION TYPE		YMTJ 160	YMTJ 200	YMTJ 230	YMTJ 250	YMTJ 315	YMTJ 400	YMTJ 500	YMTJ 630	YMTJ 800	
GEOMETRIC DISPLACEMENT	[in <sup>3</sup> /rev.]	[9.83]	[12.29]	[14.19]	[15.37]	[19.92]	[25.08]	[31.96]	[38.39]	[48.93]	
	cm <sup>3</sup> /rev.	<b>161.1</b>	<b>201.4</b>	<b>232.5</b>	<b>251.8</b>	<b>326.3</b>	<b>410.9</b>	<b>523.6</b>	<b>629.1</b>	<b>801.8</b>	
MAX. SPEED RPM	CONT.	614	615	536	495	380	302	237	196	154	
	INT.	<b>770</b>	<b>743</b>	<b>643</b>	<b>592</b>	<b>458</b>	<b>364</b>	<b>284</b>	<b>233</b>	<b>185</b>	
MAX. TORQUE [IN. LB.] N*M	CONT.	[IN. LB.]	[4166]	[5209]	[5925]	[6430]	[8508]	[9684]	[11,011]	[11,656]	[12,948]
		<b>N*M</b>	<b>471</b>	<b>589</b>	<b>670</b>	<b>727</b>	<b>962</b>	<b>1095</b>	<b>1245</b>	<b>1318</b>	<b>1464</b>
	INT.	[IN. LB.]	[507]	[6350]	[7261]	[7853]	[10,206]	[11,223]	[12,461]	[13,248]	[13,443]
		<b>N*M</b>	<b>57.3</b>	<b>718</b>	<b>821</b>	<b>888</b>	<b>1154</b>	<b>1269</b>	<b>1409</b>	<b>1498</b>	<b>1520</b>
	PEAK	[IN. LB.]	[5917]	[7411]	[8473]	[9162]	[11,907]	[12,826]	[14,538]	[14,317]	[17,250]
		<b>N*M</b>	<b>669</b>	<b>838</b>	<b>958</b>	<b>1036</b>	<b>1346.3</b>	<b>1450.3</b>	<b>1643.8</b>	<b>1618.8</b>	<b>1665</b>
MAX. OUTPUT [HP] KW	CONT.	[HP]	[37.1]	[46.8]	[46.5]	[46.2]	[46.8]	[41.8]	[38.6]	[33.9]	[29.8]
		<b>KW</b>	<b>27.7</b>	<b>34.9</b>	<b>34.7</b>	<b>34.5</b>	<b>34.9</b>	<b>31.2</b>	<b>28.8</b>	<b>25.3</b>	<b>22.2</b>
	INT.	[HP]	[42.9]	[53.6]	[53.6]	[53.6]	[53.6]	[46.9]	[46.9]	[36.8]	[35.9]
		<b>KW</b>	<b>32</b>	<b>40</b>	<b>40</b>	<b>40</b>	<b>40</b>	<b>35</b>	<b>35</b>	<b>27.5</b>	<b>26.8</b>
MAX. PRES-SURE DROP [PSI] MP <sub>A</sub>	CONT.	[PSI]	[2900]	[2900]	[2900]	[2900]	[2900]	[2610]	[2320]	[2030]	[1813]
		<b>MP<sub>A</sub></b>	<b>20</b>	<b>20</b>	<b>20</b>	<b>20</b>	<b>20</b>	<b>18</b>	<b>16</b>	<b>14</b>	<b>12.5</b>
	INT.	[PSI]	[3480]	[3480]	[3480]	[3480]	[3480]	[3045]	[2610]	[2320]	[1885]
		<b>MP<sub>A</sub></b>	<b>24</b>	<b>24</b>	<b>24</b>	<b>24</b>	<b>24</b>	<b>21</b>	<b>18</b>	<b>16</b>	<b>13</b>
PEAK	[PSI]	[4060]	[4060]	[4060]	[4060]	[4060]	[3480]	[3045]	[2755]	[2320]	
	<b>MP<sub>A</sub></b>	<b>28</b>	<b>28</b>	<b>28</b>	<b>28</b>	<b>28</b>	<b>24</b>	<b>21</b>	<b>19</b>	<b>16</b>	
MAX. FLOW [GPM] L/MIN	CONT.	[GPM]	[26.4]	[33]	[33]	[33]	[33]	[33]	[33]	[33]	[33]
		<b>L/MIN</b>	<b>100</b>	<b>125</b>	<b>125</b>	<b>125</b>	<b>125</b>	<b>125</b>	<b>125</b>	<b>125</b>	<b>125</b>
	INT.	[GPM]	[33]	[39.6]	[39.6]	[39.6]	[39.6]	[39.6]	[39.6]	[39.6]	[39.6]
		<b>L/MIN</b>	<b>125</b>	<b>150</b>	<b>150</b>	<b>150</b>	<b>150</b>	<b>150</b>	<b>150</b>	<b>150</b>	<b>150</b>
MAX. INLET PRESSURE [PSI] MP <sub>A</sub>	CONT.	[PSI]	[3045]	[3045]	[3045]	[3045]	[3045]	[3045]	[3045]	[3045]	[3045]
		<b>MP<sub>A</sub></b>	<b>21</b>	<b>21</b>	<b>21</b>	<b>21</b>	<b>21</b>	<b>21</b>	<b>21</b>	<b>21</b>	<b>21</b>
	INT.	[PSI]	[3625]	[3625]	[3625]	[3625]	[3625]	[3625]	[3625]	[3625]	[3625]
		<b>MP<sub>A</sub></b>	<b>25</b>	<b>25</b>	<b>25</b>	<b>25</b>	<b>25</b>	<b>25</b>	<b>25</b>	<b>25</b>	<b>25</b>
	PEAK	[PSI]	[4350]	[4350]	[4350]	[4350]	[4350]	[4350]	[4350]	[4350]	[4350]
		<b>MP<sub>A</sub></b>	<b>30</b>	<b>30</b>	<b>30</b>	<b>30</b>	<b>30</b>	<b>30</b>	<b>30</b>	<b>30</b>	<b>30</b>
WEIGHT [LB] KG	[LB]	[43]	[44]	[45]	[45]	[46]	[48]	[52]	[53]	[55]	
	<b>KG</b>	<b>19.5</b>	<b>20</b>	<b>20.4</b>	<b>20.5</b>	<b>21</b>	<b>22</b>	<b>23</b>	<b>24</b>	<b>25</b>	

\* Continuous pressure:

\* Intermittent pressure:

\* Peak pressure:

Max. value of operating motor continuously.

Max. value of operating motor in 6 seconds per minute.

Max. value of operating motor in 0.6 second per minute.

## PORTING DATA

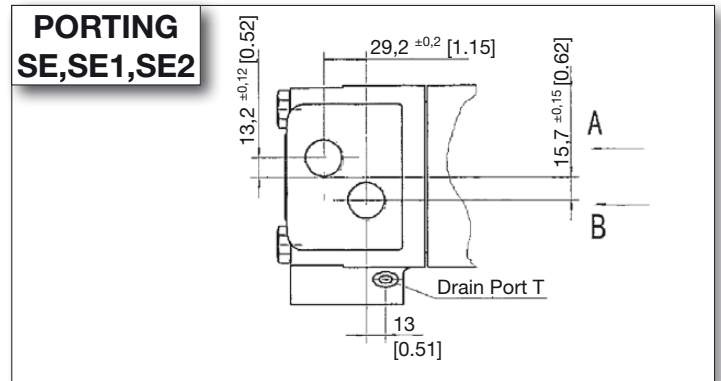
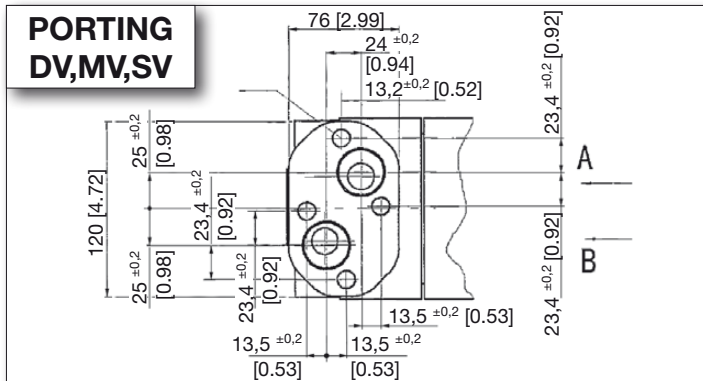
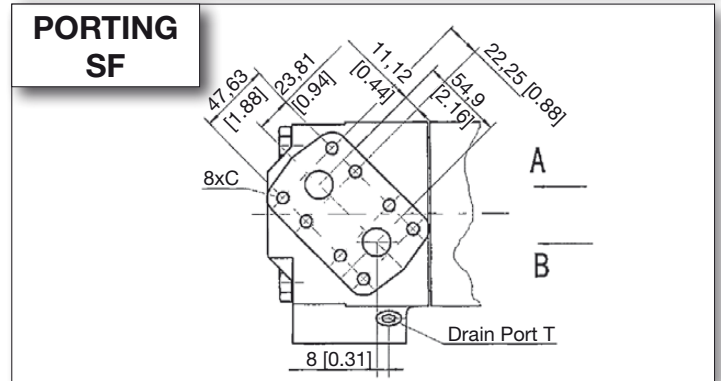
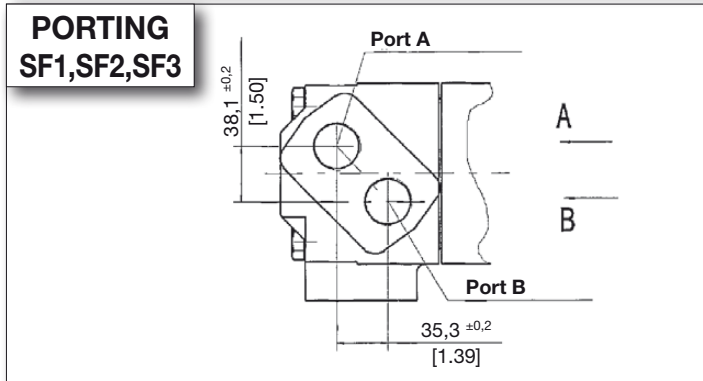
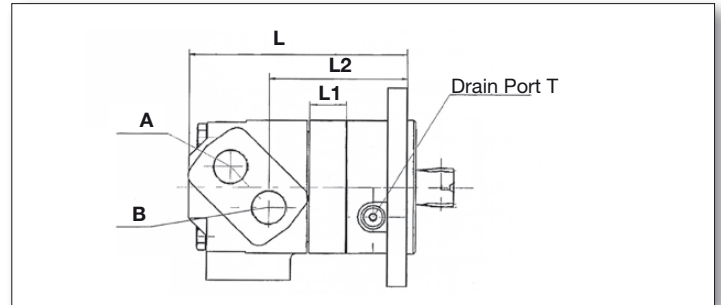
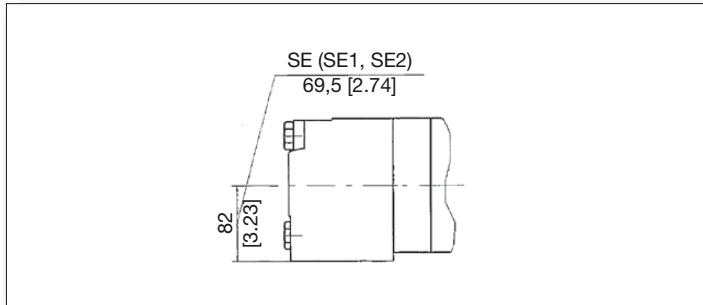

MODEL	[INCHES]			MILLIMETERS		
	L	L1	L2	L	L1	L2
YMTJ 230	[6.93]	[0.48]	[41.15]	176	12	104.5
YMTJ 250	[7.01]	[0.56]	[4.20]	178	14	106.5
YMTJ 315	[7.25]	[0.79]	[4.43]	184	20	112.5
YMTJ 400	[7.52]	[1.07]	[4.71]	191	27	119.5
YMTJ 500	[7.84]	[1.38]	[5.02]	199	35	127.5
YMTJ 630	[8.31]	[1.85]	[5.50]	211	47	139.5
YMTJ 800	[8.74]	[2.29]	[5.93]	222	58	150.5

- Note:
- 1) The dimensional data for ports SF,SF1 and SF2 are as the chart indicates
  - 2) The dimensional data for ports DV,MV and SV are as follows: L dimension-16mm and L2 dimension + 6.5mm.
  - 3) The dimensional data for ports SE,SE1,SE2 and WE are as follows: L dimension -70mm and L2 dimension -59 mm
  - 4) The thickness of the stator and rotor for displacements from 315-800 is the dimension of L1 + 7mm.

### PORT & DRAIN PORT ORDERING CODES

ORDER CODE	SF1	DEPTH	SF2	DEPTH	SF	DEPTH	DV	DEPTH	MV	DEPTH	SV/SF3	DEPTH	SE	DEPTH	SE1	DEPTH	SE2	DEPTH
PORTS - A and B	M33X2	18 mm	G1	18 mm	3/4"	18 mm	G1	18 mm	M33X2	18 mm	1-5/16-12UN	18 mm	1-16-12UN	18 mm	1-1/16-12UN	18 mm	G3/4	18 mm
TANK PORT - T	M14X1.5	12 mm	G1/4	12 mm	7/16-20UNF	12 mm	G 1/4	12 mm	M14X1.5	12 mm	7/16-20UNF	12 mm	9/16-18UNF	12 mm	7/16-20UNF	12 mm	G1/4	12 mm
BOLTS - C					8X3/8-16UNC	-	4XM12	-	4XM12	-	-	-						

## MOUNTING FLANGE DATA

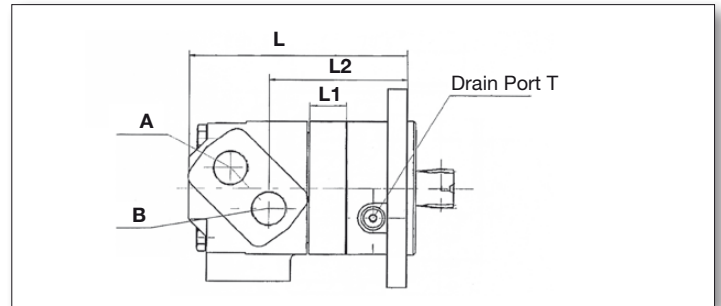
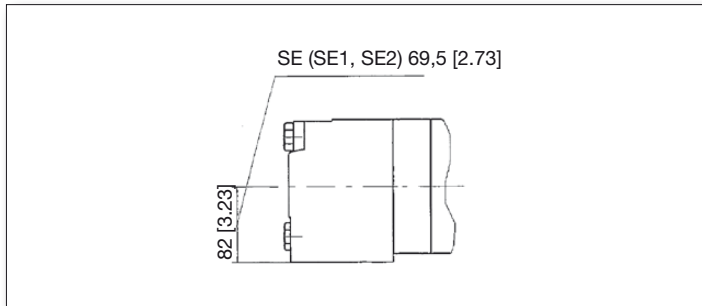

NOTE: THE THICKNESS OF THE STATOR AND ROTOR FOR DISPLACEMENTS 230-800 IS THE DIMENSION OF L1 + 7MM

### FLANGE J

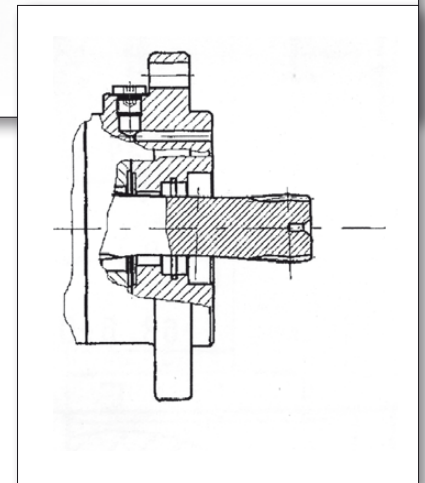
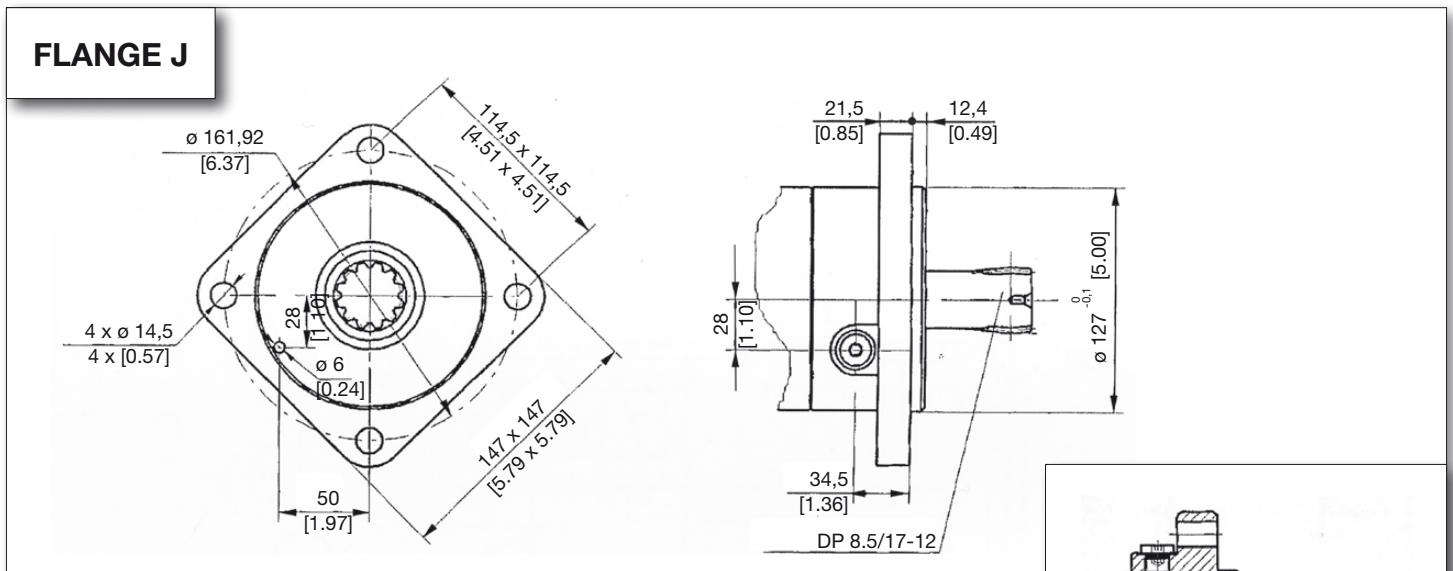

MODEL	[INCHES]			MILLIMETERS		
	L	L1	L2	L	L1	L2
YMTJ 230	[6.93]	[0.48]	[41.15]	176	12	104.5
YMTJ 250	[7.01]	[0.56]	[4.20]	178	14	106.5
YMTJ 315	[7.25]	[0.79]	[4.43]	184	20	112.5
YMTJ 400	[7.52]	[1.07]	[4.71]	191	27	119.5
YMTJ 500	[7.84]	[1.38]	[5.02]	199	35	127.5
YMTJ 630	[8.31]	[1.85]	[5.50]	211	47	139.5
YMTJ 800	[8.74]	[2.29]	[5.93]	222	58	150.5



## MOUNTING DATA

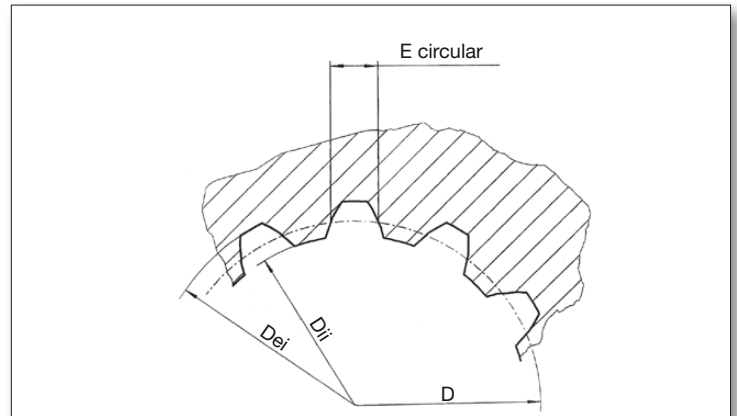
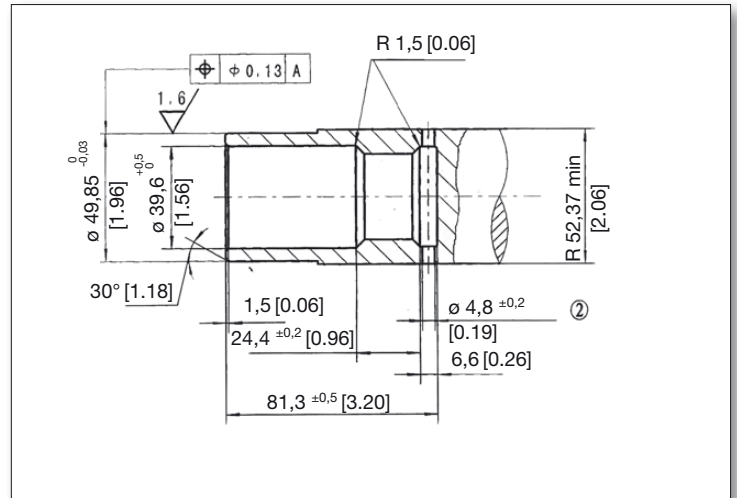
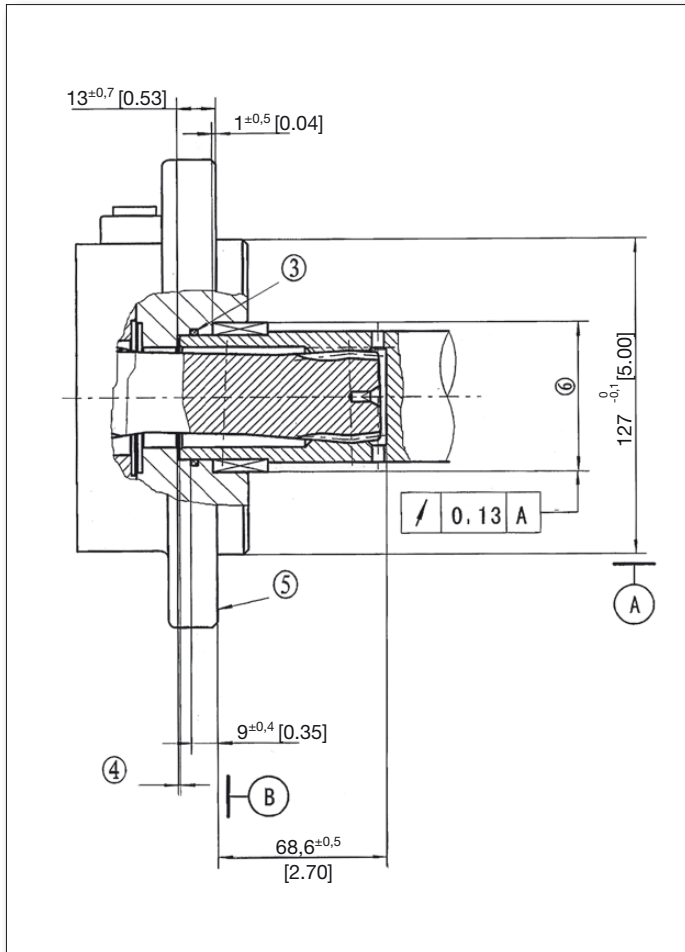

### INTERNAL SPLINE DATA FOR THE ATTACHED COMPONENT

FILLET ROOT SIDE FIT		mm
NUMBER OF TEETH	Z	12
DIAMETRAL PITCH	DP	8.5/17
PRESSURE ANGLE	D	$30^\circ$
PITCH DIA.	D	$\phi 35.858823$
MAJOR DIA.	DEI	$\phi 38.97^{+0.20}_0$
MINOR DIA.	DII	$\phi 33.3^{+0.18}_0$
SPACE WIDTH CIRCULAR	E	$5.866^{\pm 0.032}$
DIMENSION BETWEEN TWO PINS ( $\phi 4$ )	ME	$26.929-27.084$

- Internal spline in mating part to be as follows: Material to be ASTM A304, 8620H. Carborize to a hardness of 60-64 HRC with case depth (to 50HRC) of 0.75-1 [0.30-.040] (dimensions apply after heat treat).
- Mating part to have critical dimensions as shown. Oil holes must be provided and open for proper oil circulation.
- Some means of maintaining clearance between shaft and mounting flange must be provided
- Seal to be furnished with motor for proper oil circulation thru splines
- Similar to SAE "C" Four Bolt Flange
- Counterbore designed to adapt to a standard sleeve bearing 50.010-50.038 [1.9689-1.9700] ID by 60.51-60.079 [2.3642-2.3653] O.D. (Oilite Bronze sleeve bearing)

## ORDERING INFORMATION

	1	2	3	4	5	6	7	8
YMTJ								

1	2	3		4		5		6		7	
DISP.	FLANGE	OUTPUT SHAFT		PORT AND DRAIN PORT		ROTATION DIRECTION		PAINT		SPECIAL OPTIONS	
230	J Squareflange, 161.9mm pilot127mmx12.4	NONE	Short shaft12- DP8.5/17	SF	3/4",Manifold Mount,8-3/8UNC 7/16-20UNF	NONE	STANDARD	00	NO PAINT	NONE	STANDARD
250				SF1	M33X2,M14X1.5	R	REVERSE			FR	FREE RUNNING
315				SF2	G1,G1/4			B	BLACK		
400				SE	1-1/16-12 UN O-ring, 9/16-18UNF					LSV	LOW SPEED VALVE
500				SE1	1-1/16-12UNC O-ring 7/16-20 UNF						
630				SE2	G3/4,G1/4						
800				DV	G1,Manifold Mount, 4-M12 G1/4						
				MV	M33X2, Manifold Mount 4-M12,M14X1.5						
				SV	1-5/16-12UNC O-ring 7/16-20UNF						
	SF3	1-5/16-12 O-ring 7/16-20 UNF									

**ORDERING CODE:**

All options have been determined with letters, numbers or combinations. All boxes must be filled with proper codes. If specification is not in the table, please contact us with your requirements.



# YMV/YMVE



The **YMV** series motors adapts an advanced **GEROLOR** gear set designed with disc distribution flow and high pressure.

This motor series uses the **“ROLOR”** gear type manufactured with most advanced technology and quality available to provide low pressure start up, smooth reliable operation and high efficiency.

The output shaft tapered roller bearings allow for high axial and radial forces.

Advanced design in disc distribution flow, which can automatically compensate in operating with high volume efficiency and long life.

## SPECIFICATIONS

Distribution Type	Model	Displacement		Max. Operating Pressure		Speed Range Continuous	Max. Output Power	
		[in <sup>3</sup> ./rev]	[19.23~6040]	[PSI]	[4060]		RPM	[HP]
Disc Distribution	YMV	cm <sup>3</sup> /rev.	330 ~ 990	MPa	28	10 ~ 446	Kw	58

## QUICK REFERENCE GUIDE

### YMV-YMVE SERIES QUICK REFERENCE:

Displacements				
[in <sup>3</sup> ./rev]	cm <sup>3</sup> /rev.			
[20.32]	333	FLOW UP TO	225 LPM	[59 GPM]
[25.56]	419	PRESSURE UP TO	28 MPa	[4060 PSI]
[31.60]	518	TORQUE UP TO	2470 Nm	[21,84 lb.in.]
[40.63]	666	SPEED UP TO	446 RPM	
[48.87]	801			
[60.40]	990			

**Shaft Seals:** Standard high pressure shaft seals permit applications in series or without drain line when required

**Low Speed Valving:** These motors are manufactured following strict procedures to reduce tolerances between all components to permit lower speed, higher efficiency and smoother rotation at very low speeds. These motors are not for high speed or low pressure applications.

**Free Running:** Motors with this option have increased clearances in the rotor set. This allows improved mechanical efficiency, longer life and better performance for high-speed / high-flow applications, winch or similar applications where the motor is cross-ported to allow manual free turning also may benefit from this option to allow smoother easier free turning of the motor. Last, applications which have many reversals or high pressure spikes can also benefit since the pressure spikes will be reduced by relieving (cross-porting) such spikes internally in the motor. The trade off of these benefits is a slight reduction in volumetric efficiency, particularly at high pressure conditions.

**Special Motors:** These motors have special options like nickel plated shafts or housings for applications in corrosive environments.

### APPLICATION GUIDELINES:

For optimum results the following working conditions are recommended:

- \* Oil temperature should be between 20° - 60° C [68° - 180° F]
- \* Oil filter of 10 - 20 micron
- \* Oil viscosity 42 - 74 mm<sup>2</sup>/s CSA at 40° C
- \* Different shafts are used when there is a radial load or not. Check data pages
- \* For longer life we suggest the motor at start up, run for a shorter period of time (one hour) at no more than 30% of rated speed and pressure.



## SPECIFICATION DATA

DISTRIBUTION TYPE		YMV 315	YMV 400	YMV 500	YMV 630	YMV 800	YMV 1000	
GEOMETRIC DISPLACEMENT	[in./rev.]	[20.32]	[25.57]	[31.61]	[40.63]	[48.88]	[60.40]	
	<b>cm<sup>3</sup>/rev.</b>	<b>333</b>	<b>419</b>	<b>518</b>	<b>666</b>	<b>801</b>	<b>990</b>	
MAX. SPEED RPM	CONT.	446	354	386	223	185	145	
	<b>INT</b>	<b>649</b>	<b>526</b>	<b>425</b>	<b>331</b>	<b>275</b>	<b>220</b>	
MAX. TORQUE [LB. IN.] N*M	CONT.	[LB. IN.]	[8181]	[10790]	[12824]	[14504]	[16008]	[17821]
		<b>N*M</b>	<b>925</b>	<b>1220</b>	<b>1450</b>	<b>1640</b>	<b>1810</b>	<b>2015</b>
	INT.	[LB. IN.]	[9728]	[12727]	[15742]	[17688]	[18661]	[20164]
		<b>N*M</b>	<b>1100</b>	<b>1439</b>	<b>1780</b>	<b>2000</b>	<b>2110</b>	<b>2280</b>
	PEAK	[LB. IN.]	[11931]	[15035]	[18758]	[20677]	[21845]	[21226]
		<b>N*M</b>	<b>1349</b>	<b>1700</b>	<b>2121</b>	<b>2338</b>	<b>2470</b>	<b>2400</b>
MAX. OUTPUT [HP] KW	CONT.	[HP]	[58]	[61]	[78]	[52]	[47]	[38]
		<b>KW</b>	<b>43</b>	<b>45.2</b>	<b>58.6</b>	<b>38.3</b>	<b>35.1</b>	<b>28.6</b>
	INT.	[HP]	[70]	[70]	[70]	[62]	[54]	[54]
		<b>KW</b>	<b>52</b>	<b>52</b>	<b>52</b>	<b>46</b>	<b>40</b>	<b>40</b>
MAX. PRESSURE DROP [PSI] MP <sub>A</sub>	CONT.	[PSI]	[2900]	[2900]	[2900]	[2610]	[2320]	[2030]
		<b>MP<sub>A</sub></b>	<b>20</b>	<b>20</b>	<b>20</b>	<b>18</b>	<b>16</b>	<b>14</b>
	INT.	[PSI]	[3480]	[3480]	[3480]	[3045]	[2610]	[2329]
		<b>MP<sub>A</sub></b>	<b>24</b>	<b>24</b>	<b>24</b>	<b>21</b>	<b>18</b>	<b>16</b>
	PEAK	[PSI]	[4060]	[4060]	[4060]	[3480]	[3045]	[2610]
		<b>MP<sub>A</sub></b>	<b>28</b>	<b>28</b>	<b>28</b>	<b>24</b>	<b>21</b>	<b>18</b>
MAX. FLOW [GPM] L/MIN	CONT.	[GPM]	[39.6]	[39.6]	[39.6]	[39.6]	[39.6]	[39.6]
		<b>L/MIN</b>	<b>150</b>	<b>150</b>	<b>150</b>	<b>150</b>	<b>150</b>	<b>150</b>
	INT.	[GPM]	[59.4]	[59.4]	[59.4]	[59.4]	[59.4]	[59.4]
		<b>L/MIN</b>	<b>225</b>	<b>225</b>	<b>225</b>	<b>225</b>	<b>225</b>	<b>225</b>
MAX. INLET PRESSURE [PSI] MP <sub>A</sub>	CONT.	[PSI]	[3045]	[3045]	[3045]	[3045]	[3045]	[3045]
		<b>MP<sub>A</sub></b>	<b>21</b>	<b>21</b>	<b>21</b>	<b>21</b>	<b>21</b>	<b>21</b>
	INT.	[PSI]	[3625]	[3625]	[3625]	[3625]	[3625]	[3625]
		<b>MP<sub>A</sub></b>	<b>25</b>	<b>25</b>	<b>25</b>	<b>25</b>	<b>25</b>	<b>25</b>
	PEAK	[PSI]	[4350]	[4350]	[4350]	[4350]	[4350]	[4350]
		<b>MP<sub>A</sub></b>	<b>30</b>	<b>30</b>	<b>30</b>	<b>30</b>	<b>30</b>	<b>30</b>
WEIGHT [LB] KG	[LB]	[70]	[72]	[74]	[77]	[80]	[84.6]	
	<b>KG</b>	<b>31.8</b>	<b>32.6</b>	<b>33.5</b>	<b>34.9</b>	<b>36.5</b>	<b>38.6</b>	

\* Continuous pressure:

\* Intermittent pressure:

\* Peak pressure:

Max. value of operating motor continuously.

Max. value of operating motor in 6 seconds per minute.

Max. value of operating motor in 0.6 second per minute.

## PERFORMANCE DATA

YMV 315 [20.32 in<sup>3</sup>/rev] 333 cm<sup>3</sup>/rev. Max cont. Max int.

	[1015]	[1450]	[2030]	[2320]	[2610]	[2900]	[3045]	[3480]	[PSI]
	7	10	14	16	18	20	21	24	MPa
GPM	[7.9]	[2697]	[3847]	[5351]	[6350]	[6987]	[7889]	[8331]	[9375]
L/min	30	305	435	605	718	790	892	942	1060
		<b>89</b>	<b>85</b>	<b>79</b>	<b>71</b>	<b>70</b>	<b>68</b>	<b>62</b>	<b>55</b>
	[15.9]	[2680]	[3936]	[5528]	[6509]	[7323]	[8181]	[8561]	[9702]
	60	303	445	625	736	828	925	968	1097
		<b>183</b>	<b>179</b>	<b>174</b>	<b>168</b>	<b>163</b>	<b>160</b>	<b>154</b>	<b>148</b>
	[23.8]	[2653]	[3891]	[5528]	[6456]	[7305]	[8154]	[8508]	[9569]
	90	300	440	625	730	826	922	962	1082
		<b>275</b>	<b>272</b>	<b>266</b>	<b>258</b>	<b>254</b>	<b>248</b>	<b>242</b>	<b>235</b>
	[27.7]	[2609]	[3847]	[5483]	[6421]	[7270]	[8110]	[8473]	[9534]
	105	295	435	620	726	822	917	958	1078
		<b>325</b>	<b>320</b>	<b>312</b>	<b>306</b>	<b>300</b>	<b>292</b>	<b>290</b>	<b>285</b>
	[31.7]	[2565]	[3812]	[5395]	[6368]	[7252]	[8066]	[8419]	[9463]
	120	290	431	610	720	820	912	952	1070
		<b>371</b>	<b>366</b>	<b>359</b>	<b>350</b>	<b>345</b>	<b>337</b>	<b>332</b>	<b>325</b>
Max cont.	[39.6]	[2459]	[3635]	[5324]	[6332]	[7093]	[7995]	[8331]	[9348]
	150	278	411	602	716	802	904	942	1057
		<b>464</b>	<b>459</b>	<b>454</b>	<b>445</b>	<b>435</b>	<b>428</b>	<b>422</b>	<b>412</b>
Max int.	[50.2]	[2299]	[3467]	[5200]	[6279]	[7031]	[7889]	[8225]	
	190	260	392	588	710	795	892	930	
		<b>595</b>	<b>588</b>	<b>582</b>	<b>575</b>	<b>568</b>	<b>562</b>	<b>555</b>	

YMV 400 [25.56 in<sup>3</sup>/rev] 419 cm<sup>3</sup>/rev. Max cont. Max int.

	[1015]	[1450]	[2030]	[2320]	[2610]	[2900]	[3045]	[3480]	[PSI]
	7	10	14	16	18	20	21	24	MPa
GPM	[7.9]	[3467]	[5236]	[7181]	[8800]	[9286]	[10,436]	[10,569]	[12,249]
L/min	30	392	592	812	995	1050	1180	1195	1385
		<b>71</b>	<b>70</b>	<b>68</b>	<b>63</b>	<b>60</b>	<b>56</b>	<b>52</b>	<b>47</b>
	[15.9]	[3555]	[5430]	[7270]	[9021]	[9463]	[10,790]	[10,922]	[12,603]
	60	402	614	822	1020	1070	1220	1235	1425
		<b>146</b>	<b>142</b>	<b>138</b>	<b>132</b>	<b>127</b>	<b>124</b>	<b>120</b>	<b>118</b>
	[23.8]	[3502]	[5359]	[7208]	[8977]	[9419]	[10,701]	[10,834]	
	90	396	606	815	1015	1065	1210	1225	
		<b>240</b>	<b>238</b>	<b>232</b>	<b>228</b>	<b>222</b>	<b>217</b>	<b>212</b>	
	[27.7]	[3449]	[5306]	[7119]	[8932]	[9392]	[10,657]	[10,790]	
	105	390	600	805	1010	1062	1205	1220	
		<b>270</b>	<b>266</b>	<b>261</b>	<b>258</b>	<b>254</b>	<b>250</b>	<b>248</b>	
	[31.7]	[3396]	[5253]	[7058]	[8888]	[9330]	[10,613]	[10,701]	
	120	384	594	798	1005	1055	1200	1210	
		<b>294</b>	<b>290</b>	<b>286</b>	<b>284</b>	<b>280</b>	<b>276</b>	<b>272</b>	
Max cont.	[39.6]	[3317]	[5147]	[7005]	[8862]	[9198]			
	150	375	582	792	1002	1040			
		<b>370</b>	<b>365</b>	<b>360</b>	<b>358</b>	<b>355</b>			
Max int.	[50.2]	[3184]	[5076]	[6960]	[8729]	[9065]			
	190	360	574	787	987	1025			
		<b>485</b>	<b>480</b>	<b>475</b>	<b>472</b>	<b>470</b>			

YMV 500 [31.60 in<sup>3</sup>/rev] 518 cm<sup>3</sup>/rev. Max cont. Max int.

	[1015]	[1450]	[2030]	[2320]	[2610]	[2900]	[3045]	[3480]	[PSI]
	7	10	14	16	18	20	21	24	MPa
GPM	[7.9]	[3909]	[5970]	[8826]	[10,436]	[11,143]	[12,470]	[13,133]	[15,557]
L/min	30	442	675	998	1180	1260	1410	1485	1759
		<b>57</b>	<b>55</b>	<b>53</b>	<b>52</b>	<b>50</b>	<b>48</b>	<b>44</b>	<b>40</b>
	[15.9]	[4024]	[6058]	[9065]	[10,701]	[11,188]	[12,780]	[13,354]	[15,742]
	60	455	685	1025	1210	1265	1445	1510	1780
		<b>117</b>	<b>115</b>	<b>111</b>	<b>106</b>	<b>101</b>	<b>97</b>	<b>95</b>	<b>90</b>
	[23.8]	[3980]	[5996]	[9021]	[10,657]	[11,143]	[12,824]	[13,443]	[15,795]
	90	450	678	1020	1205	1260	1450	1520	1786
		<b>186</b>	<b>184</b>	<b>183</b>	<b>180</b>	<b>178</b>	<b>173</b>	<b>170</b>	<b>166</b>
	[27.7]	[3936]	[5943]	[8950]	[10,613]	[11,099]	[12,788]	[13,381]	
	105	445	672	1012	1200	1255	1446	1513	
		<b>205</b>	<b>202</b>	<b>198</b>	<b>194</b>	<b>192</b>	<b>187</b>	<b>186</b>	
	[31.7]	[3891]	[5908]	[8888]	[10,560]	[11,055]	[12,373]	[13,354]	
	120	440	668	1005	1194	1250	1399	1510	
		<b>240</b>	<b>238</b>	<b>235</b>	<b>232</b>	<b>230</b>	<b>226</b>	<b>225</b>	
Max cont.	[39.6]	[3847]	[5864]	[8844]	[10,489]	[11,020]			
	150	435	663	1000	1186	1246			
		<b>294</b>	<b>290</b>	<b>286</b>	<b>282</b>	<b>278</b>			
Max int.	[50.2]	[3785]	[5819]	[8782]					
	190	428	658	993					
		<b>373</b>	<b>368</b>	<b>362</b>					

YMV 630 [40.63 in<sup>3</sup>/rev] 666 cm<sup>3</sup>/rev. Max cont. Max int.

	[1015]	[1450]	[2030]	[2320]	[2610]	[2900]	[3045]	[3480]	[PSI]
	7	10	14	16	18	20	21	24	MPa
GPM	[7.9]	[5395]	[7783]	[11,320]	[12,417]	[14,292]	[15,742]	[16,300]	[17,564]
L/min	30	610	880	1280	1404	1616	1780	1843	1986
		<b>43</b>	<b>41</b>	<b>38</b>	<b>36</b>	<b>34</b>	<b>31</b>	<b>30</b>	<b>29</b>
	[15.9]	[5439]	[7853]	[11,816]	[12,488]	[14,398]	[15,919]		
	60	615	888	1336	1412	1628	1800		
		<b>90</b>	<b>87</b>	<b>84</b>	<b>82</b>	<b>81</b>	<b>77</b>		
	[23.8]	[5377]	[7765]	[11,771]	[12,576]	[14,504]	[16,008]		
	90	608	878	1331	1422	1640	1810		
		<b>140</b>	<b>138</b>	<b>136</b>	<b>134</b>	<b>132</b>	<b>128</b>		
	[27.7]	[5306]	[7712]	[11,727]	[12,514]	[14,433]	[15,831]		
	105	600	872	1326	1415	1632	1790		
		<b>164</b>	<b>162</b>	<b>158</b>	<b>155</b>	<b>153</b>	<b>149</b>		
	[31.7]	[5262]	[7650]	[11,586]	[12,426]	[14,372]	[15,742]		
	120	595	865	1310	1405	1625	1780		
		<b>186</b>	<b>183</b>	<b>180</b>	<b>177</b>	<b>174</b>	<b>171</b>		
Max cont.	[39.6]	[5218]	[7562]	[11,515]	[12,364]				
	150	590	855	1302	1398				
		<b>235</b>	<b>232</b>	<b>228</b>	<b>224</b>				
Max int.	[50.2]	[5183]	[7482]						
	190	586	846						
		<b>298</b>	<b>292</b>						

## PERFORMANCE DATA

YMV 800 [48.87 in<sup>3</sup>/rev] 801 cm<sup>3</sup>/rev.

Max  
cont.

	[1015]	[1450]	[2030]	[2320]	[PSI]
	7	10	14	16	MPa
GPM	[7.9]	[6987]	[10,056]	[13,991]	[15,831]
L/min	30	790	1137	1582	1790
		<b>35</b>	<b>33</b>	<b>30</b>	<b>28</b>
	[15.9]	[7093]	[10,100]	[14,062]	[16,008]
	60	802	1142	1590	1810
		<b>68</b>	<b>66</b>	<b>62</b>	<b>60</b>
Flow (L/min)	[23.8]	[7031]	[10,038]	[13,974]	[15,919]
	90	795	1135	1580	1800
		<b>110</b>	<b>107</b>	<b>102</b>	<b>100</b>
	[27.7]	[6960]	[9994]	[13,938]	[15,848]
	105	787	1130	1576	1792
		<b>129</b>	<b>125</b>	<b>120</b>	<b>117</b>
	[31.7]	[6916]	[9941]	[13,699]	[15,565]
	120	782	1124	1549	1760
		<b>146</b>	<b>142</b>	<b>136</b>	<b>132</b>
Max cont	[39.6]	[6863]	[9781]	[13,522]	
	150	776	1106	1529	
		<b>184</b>	<b>180</b>	<b>176</b>	
Max int.	[50.2]	[6792]	[9728]		
	190	768	1100		
		<b>233</b>	<b>229</b>		

Max  
cont.

Max  
int.

YMV 1000 [60.40 in<sup>3</sup>/rev] 990 cm<sup>3</sup>/rev.

Max  
cont.

	[1015]	[1450]	[2030]	[2320]	[PSI]
	7	10	14	16	MPa
GPM	[7.9]	[8649]	[12410]	[12511]	[20075]
L/min	30	978	1410	1980	2270
		<b>28</b>	<b>27</b>	<b>26</b>	<b>24</b>
	[15.9]	[8773]	[12576]	[17821]	[20129]
	60	992	1422	2015	2280
		<b>58</b>	<b>56</b>	<b>55</b>	<b>51</b>
Flow (L/min)	[23.8]	[8129]	[12603]	[17715]	[20129]
	90	987	1425	2003	2276
		<b>87</b>	<b>85</b>	<b>82</b>	<b>76</b>
	[27.7]	[8694]	[12541]	[17635]	[19837]
	105	983	1418	1994	2243
		<b>101</b>	<b>98</b>	<b>94</b>	<b>87</b>
	[31.7]	[8623]	[12461]	[17582]	[19669]
	120	975	1409	1988	2224
		<b>113</b>	<b>109</b>	<b>105</b>	<b>100</b>
Max cont	[39.6]	[8499]	[12099]	[16830]	
	150	961	1368	1903	
		<b>140</b>	<b>136</b>	<b>123</b>	
Max int.	[50.2]	[8340]	[11833]		
	190	943	1338		
		<b>170</b>	<b>158</b>		

Max  
cont.

Max  
int.

## YMV MOUNTING DATA

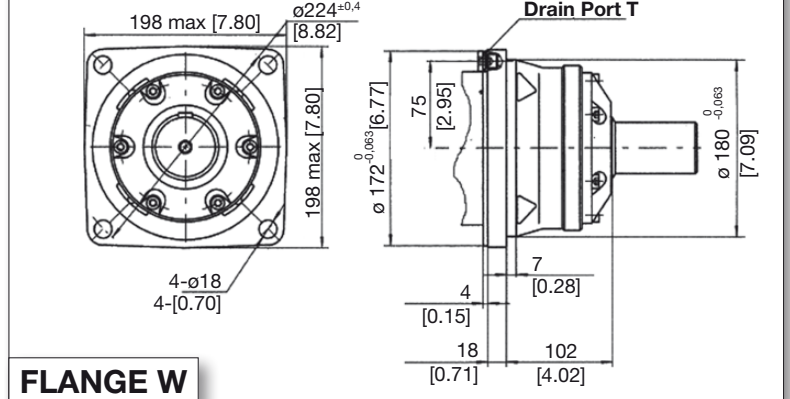
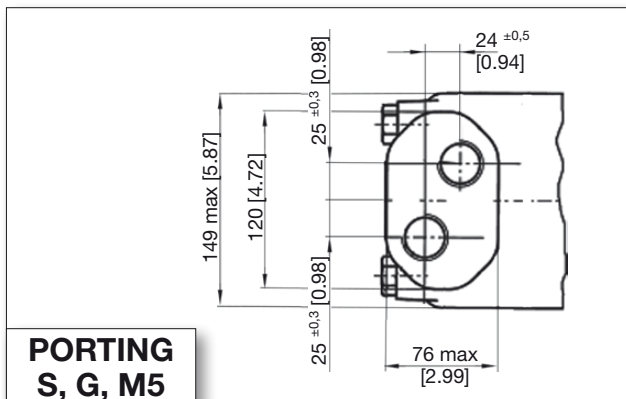
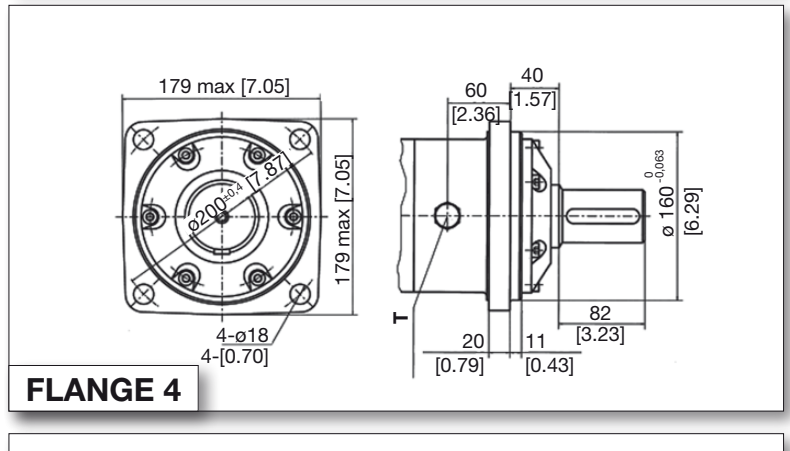
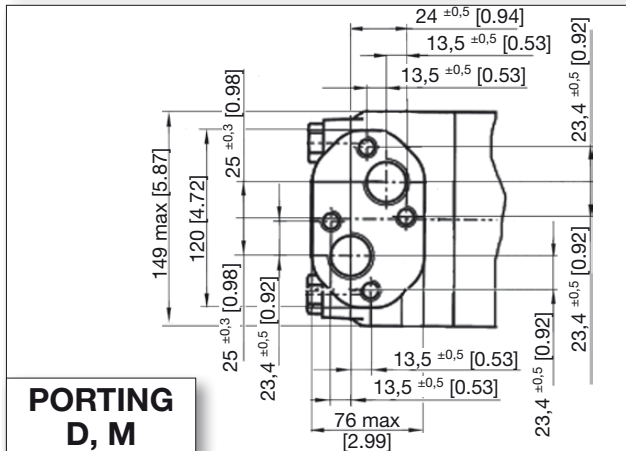
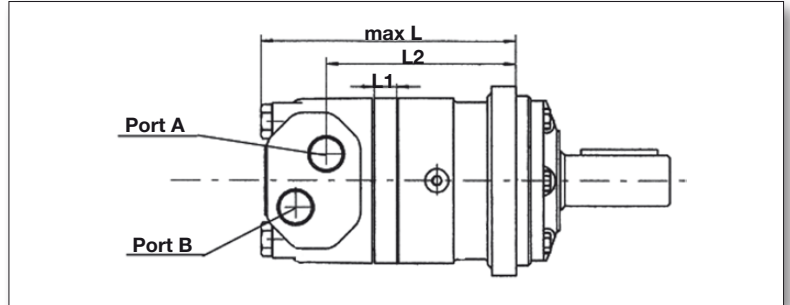
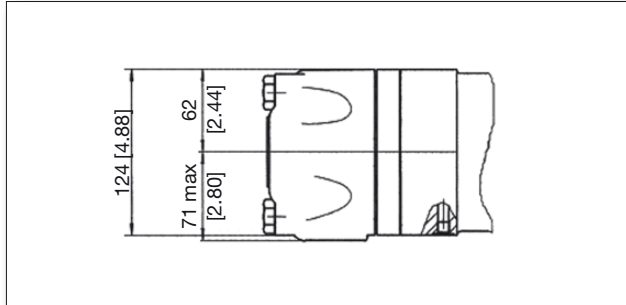

MODEL	[INCHES]			MILLIMETERS		
	L	L1	L2	L	L1	L2
YMV315	[8.55]	[0.79]	[6.36]	217	20	161.5
YMV400	[8.82]	[1.06]	[6.63]	224	27	168.5
YMV500	[9.13]	[1.38]	[6.95]	232	35	176.5
YMV630	[9.61]	[1.85]	[7.42]	244	47	188.5
YMV800	[10.04]	[2.28]	[7.85]	255	58	199.5

MODEL	[INCHES]			MILLIMETERS		
	L	L1	L2	L	L1	L2
YMVW315	[5.85]	[0.79]	[3.68]	148.5	20	93.5
YMV400	[6.12]	[1.06]	[3.96]	155.5	27	100.5
YMV500	[6.44]	[1.38]	[4.27]	163.5	35	108.5
YMV630	[6.91]	[1.85]	[4.74]	175.5	47	120.5
YMV800	[7.34]	[2.28]	[5.18]	186.5	58	131.5

### PORT & DRAIN PORT ORDERING CODES

ORDER CODE	D	DEPTH	M	DEPTH	S	DEPTH	G	DEPTH	M5	DEPTH
PORTS - A and B	G 1	18 mm	M33 X 2	18 mm	1-5/16-12UN	18 mm	G 1	18 mm	M33 X 2	18 mm
TANK PORT - T	G 1/4	12 mm	M14 X1.5	12 mm	9/16-18UNF	12 mm	G 1/4	12 mm	M14X1.5	12 mm
BOLTS - C	4-M12	10 mm	4-M12	10 mm	-	-	-	-	-	-

## YMVE MOUNTING DATA

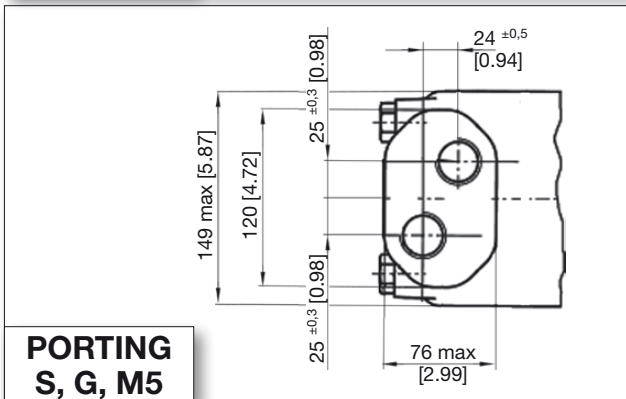
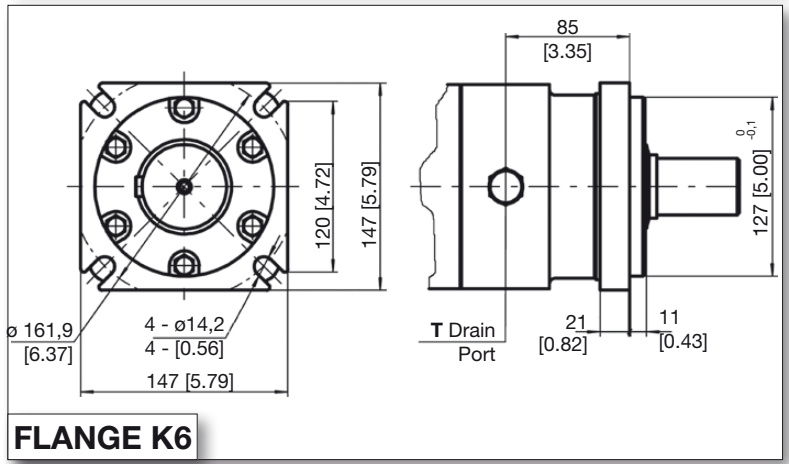
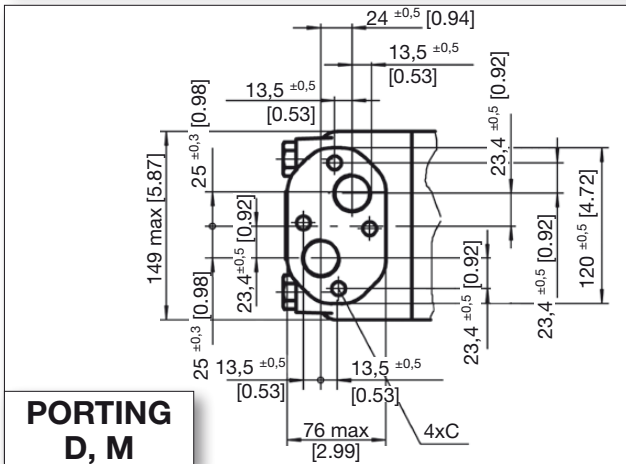
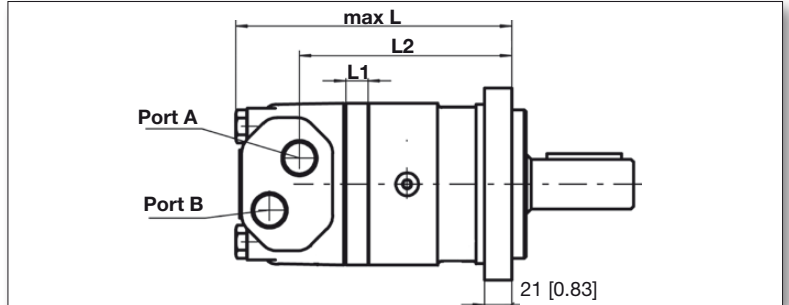
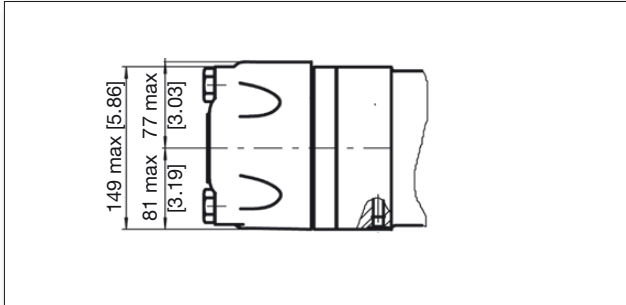

MODEL	[INCHES]			MILLIMETERS		
	L	L1	L2	L	L1	L2
YMVE315	[9.69]	[0.79]	[7.44]	246	20	189
YMVE400	[9.96]	[1.06]	[7.72]	253	27	196
YMVE500	[10.28]	[1.38]	[8.03]	261	35	204
YMVE630	[10.75]	[1.85]	[8.50]	273	47	216
YMVE800	[11.18]	[2.28]	[8.94]	284	58	227

### PORT & DRAIN PORT ORDERING CODES

ORDER CODE	D	DEPTH	M	DEPTH	S	DEPTH	G	DEPTH	M5	DEPTH
PORTS - A and B	G 1	18 mm	M33 X 2	18 mm	1-5/16-12UN	18 mm	G 1	18 mm	M33 X 2	18 mm
TANK PORT - T	G 1/4	12 mm	M14 X1.5	12 mm	9/16-18UNF	12 mm	G 1/4	12 mm	M14X1.5	12 mm
BOLTS - C	4-M12	10 mm	4-M12	10 mm	-	-	-	-	-	-

## MOTOR SHAFT EXTENSIONS

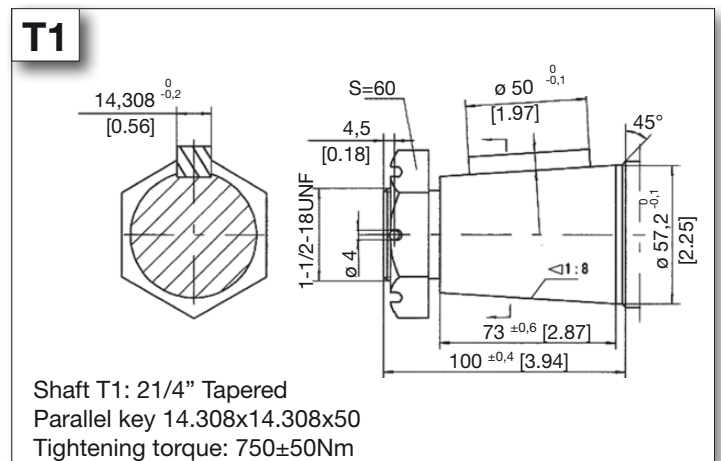
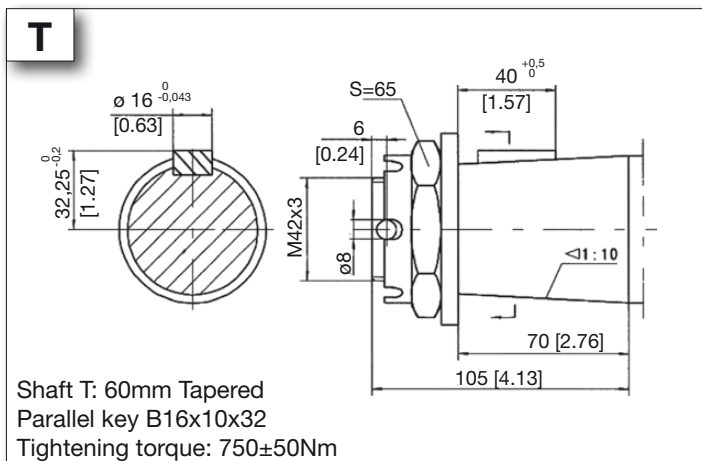
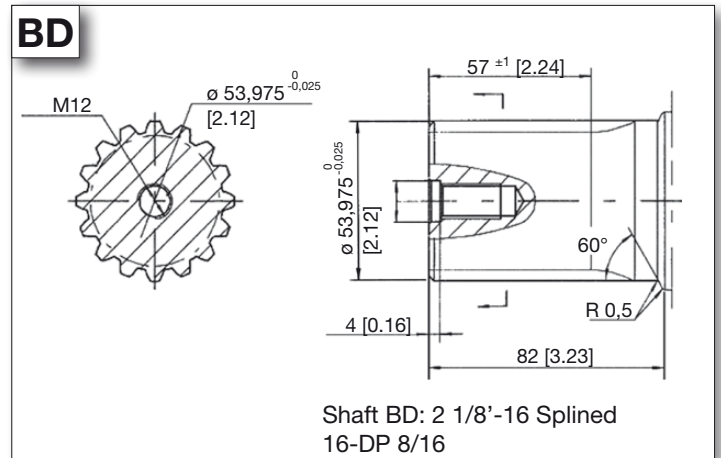
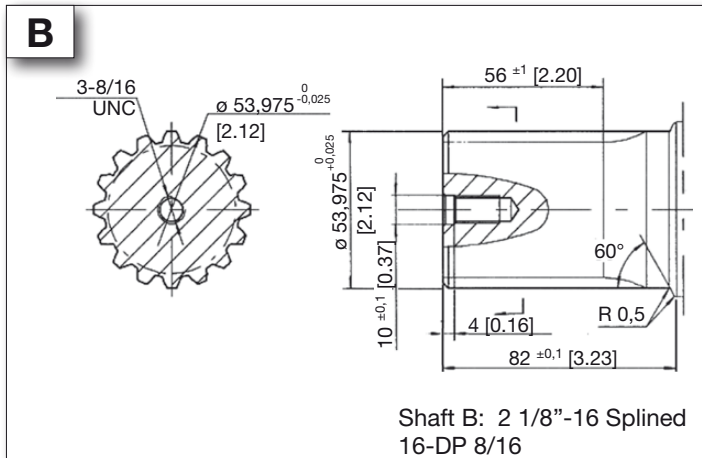
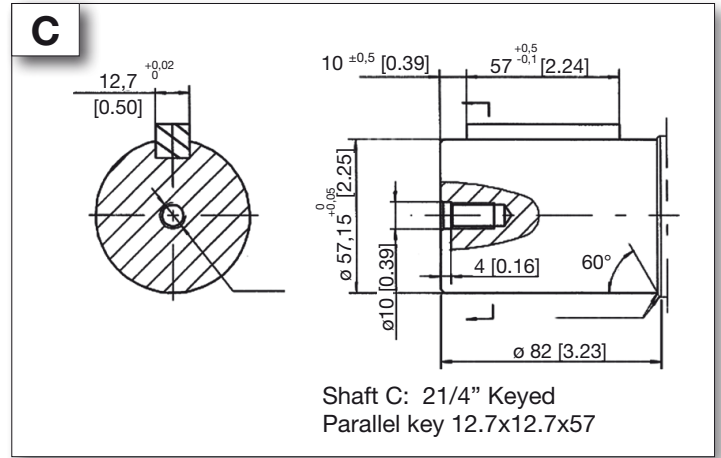
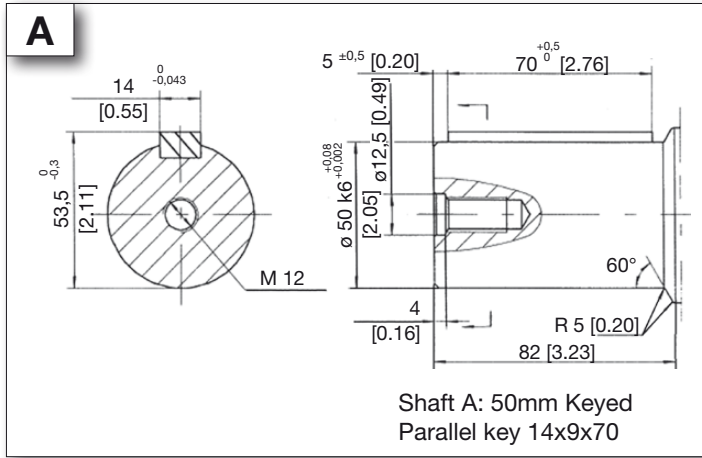

## ADDITIONAL DATA

### PERMISSIBLE SHAFT SEAL PRESSURE

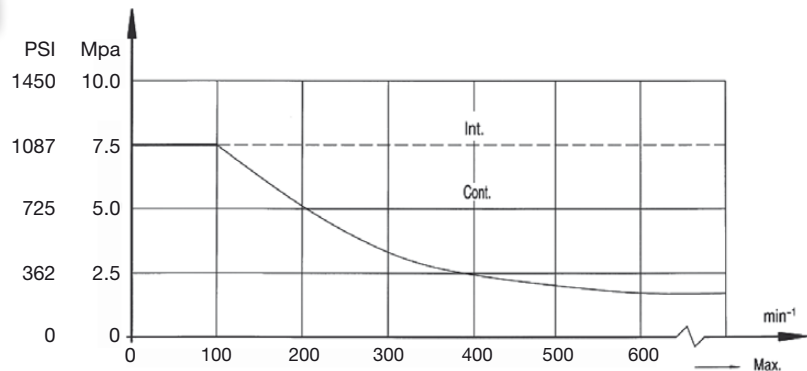
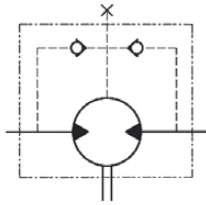

IN APPLICATIONS WITH OUT A DRAIN LINE, THE PRESSURE EXERTED ON THE SHAFT SEAL WILL EXCEED THE PRESSURE IN THE RETURN LINE. IN APPLICATIONS USING A DRAIN LINE, THE PRESSURE ON THE OUTPUT SHAFT SEAL CAN EQUAL THE PRESSURE IN DRAIN LINE.

### DIRECTION OF SHAFT ROTATION

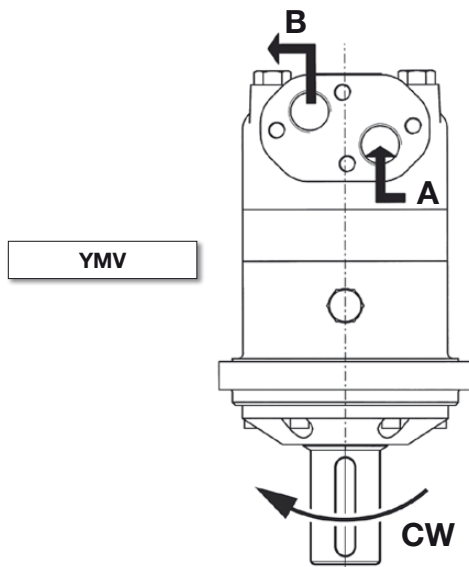

When viewing the motor from the output shaft end, port A is defined to be on the right and port B is defined to be on the left side. Standard rotation motors rotate CW when port A is pressurized. The motors are bi-directional and CCW rotation occurs when port B is pressurized.

Reverse rotation motors can special ordered which will operate with opposite rotation outlined above.

### AXIAL AND RADIAL FORCES

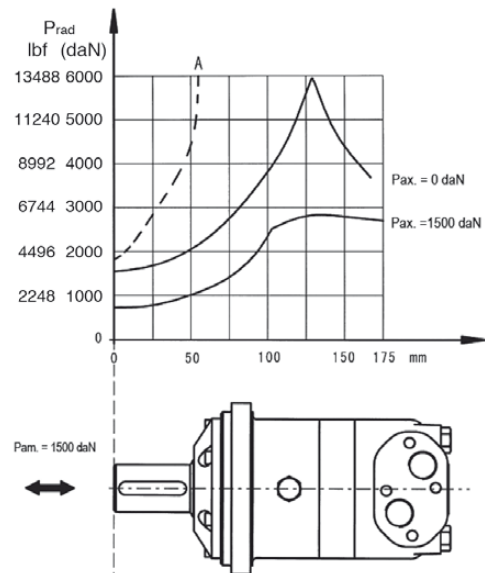

The output shaft runs in tapered bearings that permit high axial and radial forces, Curve "A" shows max radial shaft load, Any shaft loads exceeding the values quoted in the curve will involve a risk of breakage, The two other curve supply to a B10 bearing life of 3000 hours at 200 RPM.

## ORDERING INFORMATION

	1	2	3	4	5	6	7
YMV							

1	2	3	4	5	6	7			
DISP.	FLANGE	OUTPUT SHAFT	PORT AND DRAIN PORT	ROTATION DIRECTION		PAINT		SPECIAL OPTIONS	
315	4 4-Ø14.5 Square-flange, pilot Ø160x11	A Shaft:50mm Keyed , parallel key 14x9x70	D G1 Manifold 4xM12, G1/4	NONE	STANDARD	OO	NO PAINT	NONE	STANDARD
400	W 4-Ø18 Wheel- flange Ø224, pilot Ø180x10	BD Shaft: 2 1/8" Splined 16-DP8/16	M M33x2 Manifold 4xM12, M14x1.5	R	OPPOSITE			FR	FREE RUNNING
500	K6 4-Ø14.2 Square flange Pilot ø 161.9	B Shaft: 2 1/8" Splined 16-DP8/16	S 1-5/16-12UN, 9/16- 18UNF			B	BLACK		
630		C Shaft: 2 1/4" Keyed parallel key 12.7x12.7x57	G G1,G1/4					LSV	LOW SPEED VALVE
800		T 60mm Tape- red parallel key B16x10x32	M5 M33x2, M14x1.5					CRS	CORROSIVE RESISTANT SHAFT
1000		T1 2 1/4" Tapered parallel key 14.308x14.308x50	S1 1-5/16" - 12UN, 7/16-18" UNF CASE					HPS	HIGH PRESSURE SEAL
		G2 1-1/2" Keyed Shaft						HTS	HIGH TEMP SEAL

### ORDERING CODE:

All options have been determined with letters, numbers or combinations. All boxes must be filled with proper codes. If specification is not in the table, please contact us with your requirements.



# YME2



The **YME2** series motors incorporate the advanced **GEROLOR** gear set which reduces internal friction to a minimum and a “**COMMUTATOR VALVE**” distributions system which is internally balanced to reduce friction,leakage and permit better speed control.Producing higher efficiency, smoother rotation, higher speed and pressure.

This series also has many sizes and options to make it very flexible for many applications,The output shaft is supported by needle bearings for high radial and axial load for heavy duty applications,

## SPECIFICATIONS

Distribution Type	Model	Displacement		Max. Operating Pressure		Speed Range Continuous	Max. Output power	
		[in. <sup>3</sup> /rev]	[4.08-22.57]	[PSI]	[2900]		[HP]	[23.99]
commutator Distribution	YME2	cm <sup>3</sup> /rev.	66.8-370	MPa	20	RPM	Kw	17.9

## YME2 SERIES QUICK REFERENCE GUIDE

### YME2 SERIES QUICK REFERENCE:

Displacements				
[in. <sup>3</sup> /rev]	cm <sup>3</sup> /rev.			
[4.08]	66.8	FLOW UP TO	75 LPM	[19.82 GPM]
[4.97]	81.3	PRESSURE UP TO	20 MPa	[2900 PSI]
[6.20]	101.6	TORQUE UP TO	613 Nm	[5421 lb.-in.]
[7.75]	127	POWER UP TO	17,9 Kw	[24 HP]
[9.60]	157.2	SPEED UP TO	842 RPM	
[11.82]	193.6			
[13.80]	226			
[15.69]	257			
[17.57]	287.8			
[19.20]	314.5			
[22.58]	370			

**Shaft Seals:** Standard high pressure shaft seals permit applications in series or without drain line when required

**Low Speed Valving:** These motors are manufactured following strict procedures to reduce tolerances between all components to permit lower speed, higher efficiency and smoother rotation at very low speeds. These motors are not for high speed or low pressure applications.

**Free Running:** Motors with this option have increased clearances in the rotor set. This allows improved mechanical efficiency, longer life and better performance for high-speed / high-flow applications, winch or similar applications where the motor is cross-ported to allow manual free turning also remay benefit from this option to allow smoother easier free turning of the motor. Last, applications which have many reversals or high pressure spikes can also benefit since the pressure spikes will be reduced by relieving (cross-porting) such spikes internally in the motor. The trade off of these benefits is a slight reduction in volumetric efficiency, particularly at high pressure conditions.

**Special Motors:** These motors have special options like nickel plated shafts or housings for applications in corrosive environments.

### APPLICATION GUIDELINES:

For optimum results the following working conditions are recommended:

- \* Oil temperature should be between 20° - 60° C [68° - 180° F]
- \* Oil filter of 10 - 20 micron
- \* Oil viscosity 42 - 74 mm<sup>2</sup>/s CSA at 40° C
- \* Different shafts are used when there is a radial load or not. Check data pages
- \* For longer life we suggest the motor at start up, run for a shorter period of time (one hour) at no more than 30% of rated speed and pressure.

## SPECIFICATION DATA

DISTRIBUTION TYPE		YME2 65	YME2 80	YME2 100	YME2 125	YME2 160	YME2 200	YME2 230	YME2 250	YME2 295	YME2 315	YME2 375	
GEOMETRIC DISPLACEMENT	[in <sup>3</sup> /rev.]	[4.08]	[4.97]	[6.20]	[7.75]	[9.60]	[11.82]	[13.80]	[15.69]	[17.57]	[19.20]	[22.58]	
	cm <sup>3</sup> /rev.	66.8	81.3	101.6	127	157.2	193.6	226	257	287.8	314.5	370	
MAX. SPEED RPM	CONT.	667	543	439	350	283	229	247	216	196	178	152	
	INT.	842	689	553	441	355	289	328	287	254	235	199	
MAX. TORQUE [IN. LB.] N*M	CONT.	[IN. LB.]	[1114]	[1389]	[1689]	[2167]	[2715]	[3378]	[3343]	[3370]	[3476]	[3962]	[3883]
		<b>N*M</b>	<b>126</b>	<b>157</b>	<b>191</b>	<b>245</b>	<b>307</b>	<b>382</b>	<b>378</b>	<b>381</b>	<b>393</b>	<b>448</b>	<b>439</b>
	INT.	[IN. LB.]	[1557]	[1901]	[2370]	[2963]	[3732]	[4599]	[4670]	[4802]	[4838]	[5191]	[5421]
		<b>N*M</b>	<b>176</b>	<b>215</b>	<b>268</b>	<b>335</b>	<b>422</b>	<b>520</b>	<b>528</b>	<b>543</b>	<b>547</b>	<b>587</b>	<b>613</b>
MAX. OUTPUT [HP] KW	CONT.	[HP]	[11.1]	[11.8]	[10.6]	[11.9]	[11.9]	[12.0]	[13.3]	[12.5]	[11.7]	[10.2]	
		<b>KW</b>	<b>8.3</b>	<b>8.8</b>	<b>7.9</b>	<b>8.9</b>	<b>8.9</b>	<b>9</b>	<b>9.9</b>	<b>9.3</b>	<b>8.7</b>	<b>8</b>	<b>7.6</b>
	INT.	[HP]	[18.6]	[19.3]	[18.1]	[18.9]	[20.9]	[21.0]	[24.0]	[22.1]	[20.9]	[19.2]	[18.8]
		<b>KW</b>	<b>13.9</b>	<b>14.4</b>	<b>13.5</b>	<b>14.1</b>	<b>15.6</b>	<b>15.7</b>	<b>17.9</b>	<b>16.5</b>	<b>15.6</b>	<b>14.3</b>	<b>14</b>
MAX. PRESSU- RE DROP [PSI] MPa	CONT.	[PSI]	[2030]	[2030]	[2030]	[2030]	[2030]	[2030]	[1740]	[1595]	[1450]	[1450]	[1305]
		<b>MPa</b>	<b>14</b>	<b>14</b>	<b>14</b>	<b>14</b>	<b>14</b>	<b>14</b>	<b>12</b>	<b>11</b>	<b>10</b>	<b>10</b>	<b>9</b>
	INT.	[PSI]	[2755]	[2755]	[2755]	[2755]	[2755]	[2755]	[2393]	[2248]	[2103]	[1958]	[1813]
		<b>MPa</b>	<b>19</b>	<b>19</b>	<b>19</b>	<b>19</b>	<b>19</b>	<b>19</b>	<b>16.5</b>	<b>15.5</b>	<b>14.5</b>	<b>13.5</b>	<b>12.5</b>
	PEAK	[PSI]	[2900]	[2900]	[2900]	[2900]	[2900]	[2900]	[2610]	[2610]	[2465]	[2320]	[2320]
		<b>MPa</b>	<b>20</b>	<b>20</b>	<b>20</b>	<b>20</b>	<b>20</b>	<b>20</b>	<b>18</b>	<b>18</b>	<b>17</b>	<b>16</b>	<b>16</b>
MAX. FLOW [GPM] L/MIN	CONT.	[GPM]	[11.8]	[11.8]	[11.8]	[11.8]	[11.8]	[11.8]	[15.0]	[15.0]	[15.0]	[15.0]	[15.0]
		<b>L/MIN</b>	<b>45</b>	<b>45</b>	<b>45</b>	<b>45</b>	<b>45</b>	<b>45</b>	<b>45</b>	<b>57</b>	<b>57</b>	<b>57</b>	<b>57</b>
	INT.	[GPM]	[15.1]	[15.1]	[15.1]	[15.1]	[15.1]	[15.1]	[15.1]	[19.82]	[19.82]	[19.82]	[19.82]
		<b>L/MIN</b>	<b>57</b>	<b>57</b>	<b>57</b>	<b>57</b>	<b>57</b>	<b>57</b>	<b>57</b>	<b>75</b>	<b>75</b>	<b>75</b>	<b>75</b>

\* Continuous pressure:

\* Intermittent pressure:

\* Peak pressure:

Max. value of operating motor continuously.

Max. value of operating motor in 6 seconds per minute.

Max. value of operating motor in 0.6 second per minute.

## PERFORMANCE DATA

**YME2 65**  
[4.08 in<sup>3</sup>/rev] 66.8 cm<sup>3</sup>/rev.

		[507]	[1015]	[1522]	[2030]	[2755]	[PSI]
		3.5	7	10.5	14	19	MPa
GPM	[0.5]	[230]	[477]	[734]			
	2	26	54	83			
L/min	[1.3]	[239]	[495]	[769]	[1.043]		
	5	27	56	87	118		
Flow (L/min)	[2.6]	[256]	[531]	[805]	[1.088]	[1.512]	TORQUE (LB-IN)
	10	29	60	91	123	171	TORQUE (N•M)
Flow (L/min)	[4.0]	[265]	[548]	[831]	[1.114]	[1.556]	SPEED (RPM)
	15	30	62	94	126	176	
Flow (L/min)	[5.3]	[248]	[513]	[805]	[1.079]	[1.538]	
	20	28	58	91	122	174	
Flow (L/min)	[6.6]	[212]	[486]	[796]	[1.070]	[1.521]	
	25	24	55	90	121	172	
Flow (L/min)	[9.0]	[194]	[477]	[787]	[1.052]	[1.512]	
	34	22	54	89	119	171	
Max cont.	[11.9]	[177]	[460]	[752]	[1.017]	[1.486]	
	45	20	52	85	115	168	Max cont.
Max int.	[15.1]	[133]	[407]	[707]	[990]	[1.441]	
	57	15	46	80	112	163	Max int.

**YME2 100**  
[6.20 in<sup>3</sup>/rev] 101.6 cm<sup>3</sup>/rev.

		[507]	[1015]	[1522]	[2030]	[2755]	[PSI]
		3.5	7	10.5	14	19	MPa
GPM	[0.5]	[354]	[725]	[1.114]			
	2	40	82	126			
L/min	[1.3]	[363]	[734]	[1.327]	[1.822]		
	5	41	83	150	206		
Flow (L/min)	[2.6]	[371]	[805]	[1.220]	[1.565]	[2.034]	TORQUE (LB-IN)
	10	42	91	138	177	230	TORQUE (N•M)
Flow (L/min)	[4.0]	[371]	[805]	[1.220]	[1.636]	[2.273]	SPEED (RPM)
	15	42	91	138	185	257	
Flow (L/min)	[5.3]	[336]	[778]	[1203]	[1.592]	[2.158]	
	20	38	88	136	180	244	
Flow (L/min)	[6.6]	[345]	[787]	[1.256]	[1.689]	[2.370]	
	25	39	89	142	191	268	
Flow (L/min)	[9.0]	[274]	[699]	[1.158]	[1.583]	[2.211]	
	34	31	79	131	179	250	
Max cont.	[11.9]	[186]	[619]	[1.052]	[1.486]	[2.131]	
	45	21	70	119	168	241	Max cont.
Max int.	[15.1]	[88]	[531]	[964]	[1.397]	[2.052]	
	57	10	60	109	158	232	Max int.

**YME2 80**  
[4.96 in<sup>3</sup>/rev] 81.3 cm<sup>3</sup>/rev.

		[507]	[1015]	[1522]	[2030]	[2755]	[PSI]
		3.5	7	10.5	14	19	MPa
GPM	[0.5]	[292]	[619]	[937]			
	2	33	70	106			
L/min	[1.3]	[309]	[637]	[982]	[1.327]		
	5	35	72	111	150		
Flow (L/min)	[2.6]	[318]	[663]	[1.008]	[1.371]	[1.901]	TORQUE (LB-IN)
	10	36	75	114	155	215	TORQUE (N•M)
Flow (L/min)	[4.0]	[327]	[681]	[1.026]	[1.388]	[1.901]	SPEED (RPM)
	15	37	77	116	157	215	
Flow (L/min)	[5.3]	[309]	[654]	[990]	[1.335]	[1.822]	
	20	35	74	112	151	206	
Flow (L/min)	[6.6]	[309]	[628]	[955]	[1.309]	[1.786]	
	25	35	71	108	148	202	
Flow (L/min)	[9.0]	[274]	[610]	[929]	[1.282]	[1.751]	
	34	31	69	105	145	198	
Max cont.	[11.9]	[203]	[548]	[884]	[1.229]	[1.06]	
	45	23	62	100	139	12	Max cont.
Max int.	[15.1]	[159]	[486]	[867]	[1.185]	[1.645]	
	57	18	55	98	134	186	Max int.

**YME2 125**  
[7.75 in<sup>3</sup>/rev] 127 cm<sup>3</sup>/rev.

		[507]	[1015]	[1522]	[2030]	[2755]	[PSI]
		3.5	7	10.5	14	19	MPa
GPM	[0.5]	[460]	[1.327]	[1.397]			
	2	52	150	158			
L/min	[1.3]	[486]	[990]	[1.503]	[1.954]	[2.565]	
	5	55	112	170	221	290	
Flow (L/min)	[2.6]	[504]	[1.035]	[1.592]	[2.140]	[2.962]	TORQUE (LB-IN)
	10	57	117	180	242	335	TORQUE (N•M)
Flow (L/min)	[4.0]	[495]	[1.044]	[1.592]	[2.167]	[2.927]	SPEED (RPM)
	15	56	118	180	245	331	
Flow (L/min)	[5.3]	[486]	[1.035]	[1.574]	[2.140]	[2.927]	
	20	55	117	178	242	331	
Flow (L/min)	[6.6]	[460]	[982]	[1.565]	[2.105]	[2.874]	
	25	52	111	177	238	325	
Flow (L/min)	[9.0]	[380]	[929]	[1.495]	[2.043]	[2.883]	
	34	43	105	169	231	326	
Max cont.	[11.9]	[336]	[840]	[1.406]	[1.937]	[2.777]	
	45	38	95	159	219	314	Max cont.
Max int.	[15.1]	[186]	[1.556]	[1.247]	[2.476]	[2.671]	
	57	21	176	141	280	302	Max int.

## PERFORMANCE DATA

**YME2 160**  
[9.59 in<sup>3</sup>/rev] 157.2 cm<sup>3</sup>/rev.

	[507] 3.5	[1015] 7	[1522] 10.5	[2030] 14	[2755] 19	[PSI] MPa
GPM L/min	[0.5] 2	[566] 64 <b>10</b>	[1.167] 132 <b>8</b>	[1.760] 199 <b>2</b>		
	[1.3] 5	[601] 68 <b>28</b>	[1.220] 138 <b>26</b>	[1.839] 208 <b>19</b>	[2.485] 281 <b>10</b>	
Flow (L/min)	[2.6] 10	[628] 71 <b>62</b>	[1.300] 147 <b>60</b>	[1.954] 221 <b>56</b>	[2.680] 303 <b>53</b>	[3.706] 419 <b>38</b>
	[4.0] 15	[637] 72 <b>93</b>	[1.309] 148 <b>91</b>	[1.990] 225 <b>87</b>	[2.715] 307 <b>79</b>	[3.767] 426 <b>61</b>
Max cont.	[5.3] 20	[628] 71 <b>126</b>	[1.309] 148 <b>123</b>	[1.972] 223 <b>118</b>	[2.697] 305 <b>110</b>	[3.732] 422 <b>95</b>
	[6.6] 25	[548] 62 <b>157</b>	[1.238] 140 <b>155</b>	[1.928] 218 <b>152</b>	[2.618] 296 <b>141</b>	[3.670] 415 <b>129</b>
Max int.	[9.0] 34	[495] 56 <b>214</b>	[1.185] 134 <b>211</b>	[1.866] 211 <b>206</b>	[2.538] 287 <b>197</b>	[3.608] 408 <b>181</b>
	[11.9] 45	[416] 47 <b>283</b>	[1.123] 127 <b>281</b>	[1.813] 205 <b>275</b>	[2.485] 281 <b>266</b>	[3.458] 391 <b>241</b>
	[15.1] 57	[318] 36 <b>355</b>	[858] 97 <b>352</b>	[1.610] 182 <b>346</b>	[2.299] 260 <b>336</b>	[3.272] 370 <b>311</b>

TORQUE (LB-IN)  
TORQUE (N•M)  
SPEED (RPM)

**YME2 200**  
[11.81 in<sup>3</sup>/rev] 193.6 cm<sup>3</sup>/rev.

	[507] 3.5	[1015] 7	[1522] 10.5	[2030] 14	[2755] 19	[PSI] MPa
GPM L/min	[0.5] 2	[707] 80 <b>9</b>	[1.441] 163 <b>7</b>	[2.167] 245 <b>3</b>		
	[1.3] 5	[778] 88 <b>23</b>	[1.574] 178 <b>21</b>	[2.352] 266 <b>18</b>	[3.113] 352 <b>12</b>	
Flow (L/min)	[2.6] 10	[787] 89 <b>49</b>	[1.601] 181 <b>48</b>	[2.432] 275 <b>43</b>	[3.343] 378 <b>39</b>	[4.572] 517 <b>27</b>
	[4.0] 15	[805] 91 <b>76</b>	[1.663] 188 <b>73</b>	[2.476] 280 <b>68</b>	[3.378] 382 <b>63</b>	[4.599] 520 <b>44</b>
Max cont.	[5.3] 20	[787] 89 <b>101</b>	[1.610] 182 <b>98</b>	[2.432] 275 <b>95</b>	[3.308] 374 <b>86</b>	[4.572] 517 <b>69</b>
	[6.6] 25	[690] 78 <b>127</b>	[1.503] 170 <b>125</b>	[2.397] 271 <b>121</b>	[3.325] 376 <b>113</b>	[4.581] 518 <b>101</b>
Max int.	[9.0] 34	[566] 64 <b>173</b>	[1.397] 158 <b>171</b>	[2.370] 268 <b>165</b>	[3.210] 363 <b>156</b>	[4.440] 502 <b>143</b>
	[11.9] 45	[451] 51 <b>229</b>	[1.388] 157 <b>227</b>	[2.229] 252 <b>221</b>	[3.104] 351 <b>212</b>	[4.369] 494 <b>196</b>
	[15.1] 57	[318] 36 <b>289</b>	[1.220] 138 <b>286</b>	[2.043] 231 <b>279</b>	[2.918] 330 <b>271</b>	[4.148] 469 <b>256</b>

TORQUE (LB-IN)  
TORQUE (N•M)  
SPEED (RPM)

**YME2 230**  
[13.79 in<sup>3</sup>/rev] 226 cm<sup>3</sup>/rev.

	[507] 3.5	[1015] 7	[1522] 10.5	[1740] 12	[2392] 16.5	[PSI] MPa
GPM L/min	[0.5] 2	[858] 97 <b>7</b>	[1.689] 191 <b>4</b>	[2.476] 280 <b>2</b>		
	[1.3] 5	[893] 101 <b>18</b>	[1.760] 199 <b>14</b>	[2.662] 301 <b>8</b>	[3.078] 348 <b>4</b>	
Flow (L/min)	[2.6] 10	[911] 103 <b>43</b>	[1.893] 214 <b>42</b>	[2.874] 325 <b>40</b>	[3.343] 378 <b>36</b>	[4.661] 527 <b>29</b>
	[4.0] 15	[920] 104 <b>65</b>	[1.901] 215 <b>63</b>	[2.892] 327 <b>59</b>	[3.316] 375 <b>52</b>	[4.670] 528 <b>47</b>
Max cont.	[5.3] 20	[893] 101 <b>86</b>	[1.857] 210 <b>84</b>	[2.839] 321 <b>81</b>	[3.281] 371 <b>75</b>	[4.634] 524 <b>66</b>
	[6.6] 25	[840] 95 <b>108</b>	[1.778] 201 <b>106</b>	[2.795] 316 <b>102</b>	[3.219] 364 <b>94</b>	[4.519] 511 <b>87</b>
Max int.	[9.0] 34	[725] 82 <b>147</b>	[1.663] 188 <b>145</b>	[2.724] 308 <b>141</b>	[3.166] 358 <b>135</b>	[4.431] 501 <b>128</b>
	[11.9] 45	[486] 55 <b>197</b>	[1.397] 158 <b>195</b>	[2.441] 276 <b>191</b>	[2.910] 329 <b>186</b>	[4.289] 485 <b>176</b>
	[15.1] 57	[168] 19 <b>247</b>	[1.150] 130 <b>244</b>	[2.264] 256 <b>240</b>	[2.662] 301 <b>230</b>	[3.989] 451 <b>221</b>
	[19.8] 75		[575] 65 <b>328</b>	[1.618] 183 <b>323</b>	[2.211] 250 <b>311</b>	[3.546] 401 <b>303</b>

TORQUE (LB-IN)  
TORQUE (N•M)  
SPEED (RPM)

**YME2 250**  
[15.68 in<sup>3</sup>/rev] 257 cm<sup>3</sup>/rev.

	[507] 3.5	[1015] 7	[1522] 10.5	[1595] 11	[2247] 15.5	[PSI] MPa
GPM L/min	[0.5] 2	[990] 112 <b>6</b>	[1.831] 207 <b>3</b>	[2.733] 309 <b>1</b>		
	[1.3] 5	[1.017] 115 <b>18</b>	[1.928] 218 <b>14</b>	[2.830] 320 <b>8</b>	[3.078] 348 <b>4</b>	
Flow (L/min)	[2.6] 10	[999] 113 <b>39</b>	[2.078] 235 <b>38</b>	[3.166] 358 <b>35</b>	[3.352] 379 <b>31</b>	[4.802] 543 <b>23</b>
	[4.0] 15	[999] 113 <b>58</b>	[2.069] 234 <b>56</b>	[3.157] 357 <b>53</b>	[3.369] 381 <b>45</b>	[4.793] 542 <b>3</b>
Max cont.	[5.3] 20	[982] 111 <b>77</b>	[2.061] 233 <b>75</b>	[3.148] 356 <b>72</b>	[3.325] 376 <b>65</b>	[4.785] 541 <b>48</b>
	[6.6] 25	[964] 109 <b>97</b>	[2.016] 228 <b>95</b>	[3.131] 354 <b>89</b>	[3.281] 371 <b>81</b>	[4.705] 532 <b>69</b>
Max int.	[9.0] 34	[805] 91 <b>131</b>	[1.884] 213 <b>128</b>	[3.060] 346 <b>123</b>	[3.219] 364 <b>116</b>	[4.608] 521 <b>103</b>
	[11.9] 45	[787] 89 <b>174</b>	[1.866] 211 <b>172</b>	[3.051] 345 <b>165</b>	[3.193] 361 <b>157</b>	[4.581] 518 <b>135</b>
	[15.1] 57	[646] 73 <b>216</b>	[1.839] 208 <b>213</b>	[2.998] 339 <b>205</b>	[3.025] 342 <b>197</b>	[4.307] 487 <b>184</b>
	[19.8] 75		[654] 74 <b>287</b>	[1.751] 198 <b>284</b>	[2.662] 301 <b>278</b>	[3.900] 441 <b>267</b>

TORQUE (LB-IN)  
TORQUE (N•M)  
SPEED (RPM)

## PERFORMANCE DATA

### YME2 295

[17.56 in<sup>3</sup>/rev] 287.8 cm<sup>3</sup>/rev.

Max cont. Max int.

		[507]	[1015]	[1595]	[2102]	[PSI]
		3.5	7	11	14.5	MPa
GPM	[1.3]	<b>[1.070]</b>	<b>[2.149]</b>	<b>[3.254]</b>	<b>[4.502]</b>	TORQUE [LB-IN] TORQUE (N•M) SPEED (RPM)
	L/min	121	243	368	509	
5	[2.6]	<b>[1.105]</b>	<b>[2.237]</b>	<b>[3.369]</b>	<b>[4.678]</b>	
	10	125	253	381	529	
[4.0]	[2.6]	33	31	27	20	
	15	<b>[1.141]</b>	<b>[2.308]</b>	<b>[3.476]</b>	<b>[4.838]</b>	
Flow (L/min)	15	129	261	393	547	
	[5.3]	<b>[1.123]</b>	<b>[2.291]</b>	<b>[3.449]</b>	<b>[4.820]</b>	
20	[5.3]	127	259	390	545	
	[6.6]	<b>[1.114]</b>	<b>[2.255]</b>	<b>[3.414]</b>	<b>[4.767]</b>	
25	[6.6]	126	255	386	539	
	[9.0]	<b>[1.088]</b>	<b>[2.193]</b>	<b>[3.361]</b>	<b>[4.696]</b>	
34	[9.0]	123	248	380	531	
	[11.9]	<b>[1.017]</b>	<b>[2.069]</b>	<b>[3.255]</b>	<b>[4.616]</b>	
45	[11.9]	115	234	368	522	
	[15.1]	<b>[955]</b>	<b>[2.007]</b>	<b>[3.175]</b>	<b>[4.546]</b>	
Max cont.	57	108	227	359	514	Max cont.
Max int.	[19.8]		<b>[1.866]</b>	<b>[3.086]</b>	<b>[4.475]</b>	Max int.
	75		211	349	506	
			254	246	231	

### YME2 315

[19.19 in<sup>3</sup>/rev] 314.5 cm<sup>3</sup>/rev.

Max cont. Max int.

		[507]	[1015]	[1595]	[1957]	[PSI]
		3.5	7	11	13.5	MPa
GPM	[1.3]	<b>[1.203]</b>	<b>[2.485]</b>	<b>[3.776]</b>		TORQUE [LB-IN] TORQUE (N•M) SPEED (RPM)
	L/min	136	281	427		
5	[2.6]	<b>[1.230]</b>	<b>[2.583]</b>	<b>[3.874]</b>	<b>[5.076]</b>	
	10	139	287	438	574	
[4.0]	[2.6]	30	29	26	20	
	15	<b>[1.247]</b>	<b>[2.609]</b>	<b>[3.962]</b>	<b>[5.191]</b>	
Flow (L/min)	15	141	295	448	587	
	[5.3]	<b>[1.220]</b>	<b>[2.538]</b>	<b>[3.909]</b>	<b>[5.191]</b>	
20	[5.3]	138	287	442	587	
	[6.6]	<b>[1.158]</b>	<b>[2.476]</b>	<b>[3.812]</b>	<b>[5.014]</b>	
25	[6.6]	131	280	431	567	
	[9.0]	<b>[1.035]</b>	<b>[2.379]</b>	<b>[3.741]</b>	<b>[4.926]</b>	
34	[9.0]	117	269	423	557	
	[11.9]	<b>[1.088]</b>	<b>[2.237]</b>	<b>[3.511]</b>	<b>[4.731]</b>	
45	[11.9]	114	253	397	535	
	[15.1]	<b>[760]</b>	<b>[1.937]</b>	<b>[3.387]</b>	<b>[4.466]</b>	
Max cont.	57	86	219	383	505	Max cont.
Max int.	[19.8]		<b>[955]</b>	<b>[2.538]</b>	<b>[3.679]</b>	Max int.
	75		108	287	416	
			235	231	219	

### YME2 375

[22.57 in<sup>3</sup>/rev] 370 cm<sup>3</sup>/rev.

Max cont. Max int.

		[507]	[1015]	[1305]	[1812]	[PSI]
		3.5	7	9	12.5	MPa
GPM	[1.3]	<b>[1.335]</b>	<b>[2.786]</b>	<b>[3.644]</b>		TORQUE [LB-IN] TORQUE (N•M) SPEED (RPM)
	L/min	151	315	412		
5	[2.6]	<b>[1.371]</b>	<b>[2.865]</b>	<b>[3.776]</b>	<b>[5.359]</b>	
	10	155	324	427	606	
[4.0]	[2.6]	25	24	21	18	
	15	<b>[1.433]</b>	<b>[2.927]</b>	<b>[3.882]</b>	<b>[5.421]</b>	
Flow (L/min)	15	162	331	439	613	
	[5.3]	<b>[1.397]</b>	<b>[2.883]</b>	<b>[3.838]</b>	<b>[5.324]</b>	
20	[5.3]	158	326	434	602	
	[6.6]	<b>[1.335]</b>	<b>[2.795]</b>	<b>[3.750]</b>	<b>[5.209]</b>	
25	[6.6]	151	316	424	589	
	[9.0]	<b>[1.247]</b>	<b>[2.733]</b>	<b>[3.688]</b>	<b>[5.129]</b>	
34	[9.0]	141	309	417	580	
	[11.9]	<b>[1.220]</b>	<b>[2.653]</b>	<b>[3.608]</b>	<b>[5.059]</b>	
45	[11.9]	138	300	408	572	
	[15.1]	<b>[1.044]</b>	<b>[2.485]</b>	<b>[3.476]</b>	<b>[4.864]</b>	
Max cont.	57	118	281	393	550	Max cont.
Max int.	[19.8]		<b>[2.282]</b>	<b>[3.263]</b>	<b>[4.581]</b>	Max int.
	75		258	369	518	
			199	191	183	

## DIMENSION AND MOUNTING DATA

Code: Wheel Mount WS: 7/8-14 O-RING - WD: G1/2 - WM: M22X1.5

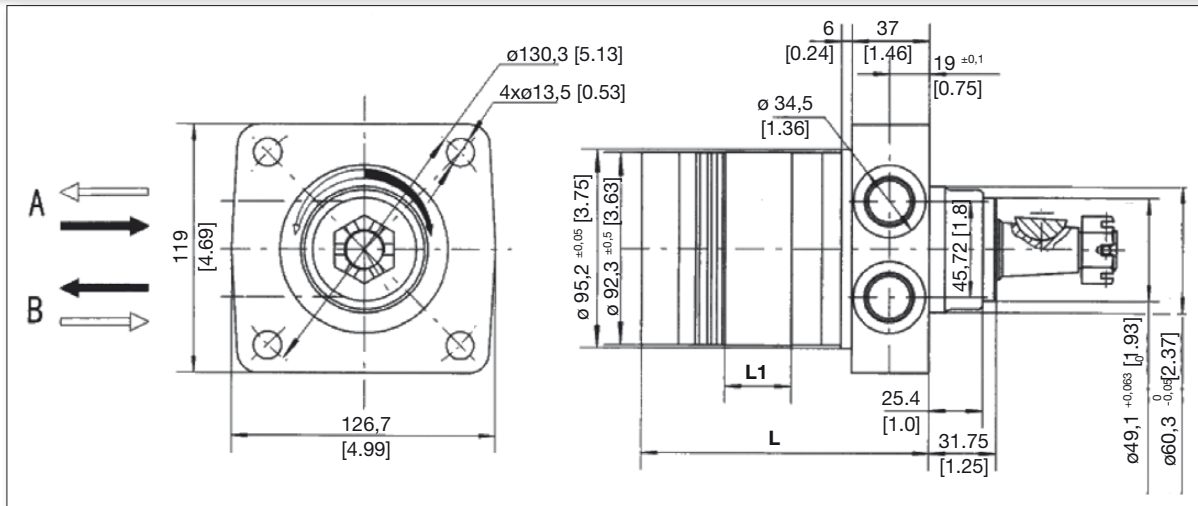

DISPLACEMENT <sup>CM</sup> ³/REV	65	80	100	125	160	200	230	250	295	315	375
L1 (inches)	[0.51]	[0.63]	[0.79]	[0.98]	[1.20]	[1.50]	[1.73]	[1.97]	[2.20]	[2.44]	[2.91]
L1 (mm)	13	16	20	25	30.5	38.1	44	50	56	62	74
L (inches)	[4.69]	[4.80]	[4.96]	[5.16]	[5.37]	[5.67]	[5.91]	[6.14]	[6.38]	[6.61]	[7.09]
L (mm)	119	122	126	131	136.5	144	150	156	162	168	180
WEIGHT (lb)	[16]	[16]	[17]	[18]	[18]	[19]	[20]	[21]	[22]	[23]	[24]
WEIGHT (kg)	7.4	7.5	7.8	8	8.3	8.7	9.2	9.6	10	10.3	10.8

Code: HM Manifold • A. B Port 1/2"

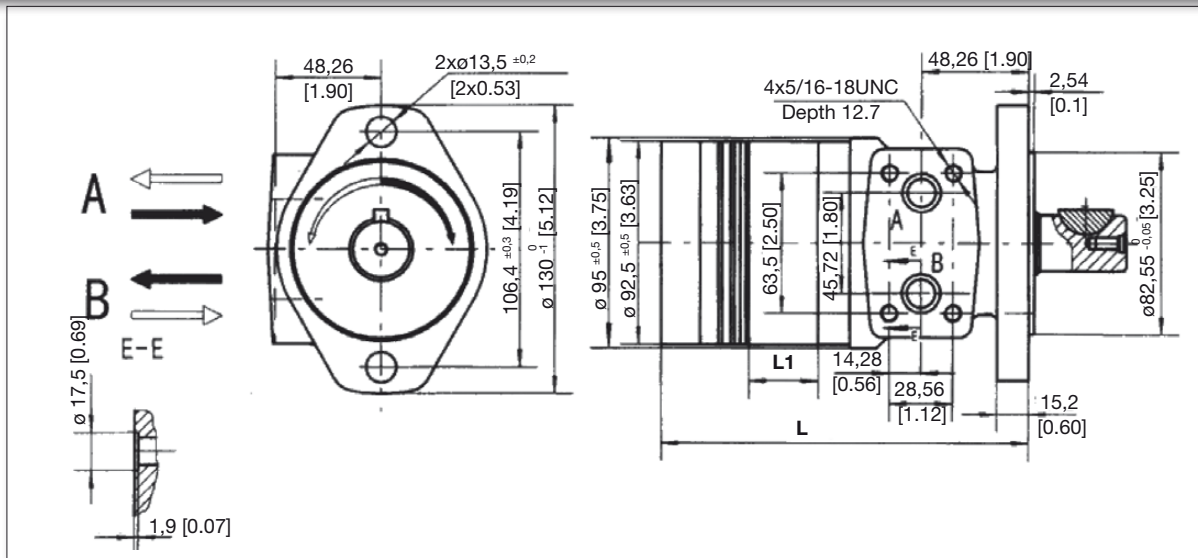

DISPLACEMENT <sup>CM</sup> ³/REV	65	80	100	125	160	200	230	250	295	315	375
L1 (inches)	[0.51]	[0.63]	[0.79]	[0.98]	[1.20]	[1.50]	[1.73]	[1.97]	[2.20]	[2.44]	[2.91]
L1 (mm)	13	16	20	25	30.5	38.1	44	50	56	62	74
L (inches)	[5.87]	[5.98]	[6.14]	[6.34]	[6.56]	[6.85]	[7.09]	[7.32]	[7.56]	[7.80]	[8.27]
L (mm)	149	152	156	161	166.5	174	180	186	192	198	210
WEIGHT (lb)	[14]	[14]	[15]	[15]	[16]	[17]	[18]	[19]	[20]	[20]	[21]
WEIGHT (kg)	6.4	6.5	6.8	7	7.3	7.7	8.2	8.6	9	9.3	9.8

## DIMENSION AND MOUNTING DATA

Code: Port A. B • HS 7/8-14 UNF • HP 1/2-14NPTF • HD G1/2 • HG M22x1,5

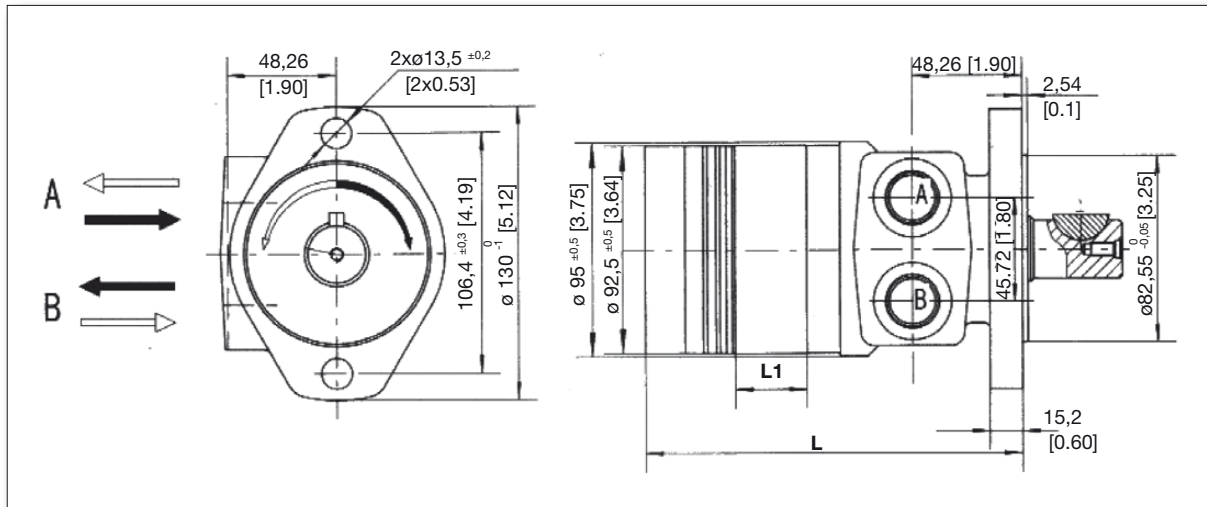

DISPLACEMENT <sup>CM<sup>3</sup>/REV</sup>	65	80	100	125	160	200	230	250	295	315	375
L1 (inches)	[0.51]	[0.63]	[0.79]	[0.98]	[1.20]	[1.50]	[1.73]	[1.97]	[2.20]	[2.44]	[2.91]
L1 (mm)	13	16	20	25	30.5	38.1	44	50	56	62	74
L (inches)	[5.87]	[5.98]	[6.14]	[6.34]	[6.56]	[6.85]	[7.09]	[7.32]	[7.56]	[7.80]	[8.27]
L (mm)	149	152	156	161	166.5	174	180	186	192	198	210
WEIGHT (lb)	[14]	[14]	[15]	[15]	[16]	[17]	[18]	[19]	[20]	[20]	[21]
WEIGHT (kg)	6.4	6.5	6.8	7	7.3	7.7	8.2	8.6	9	9.3	9.8

Code: Port A. B • H4S 7/8-14 UNF • H4P 1/2-14NPTF • H4D G1/2 • H4G M22x1,5

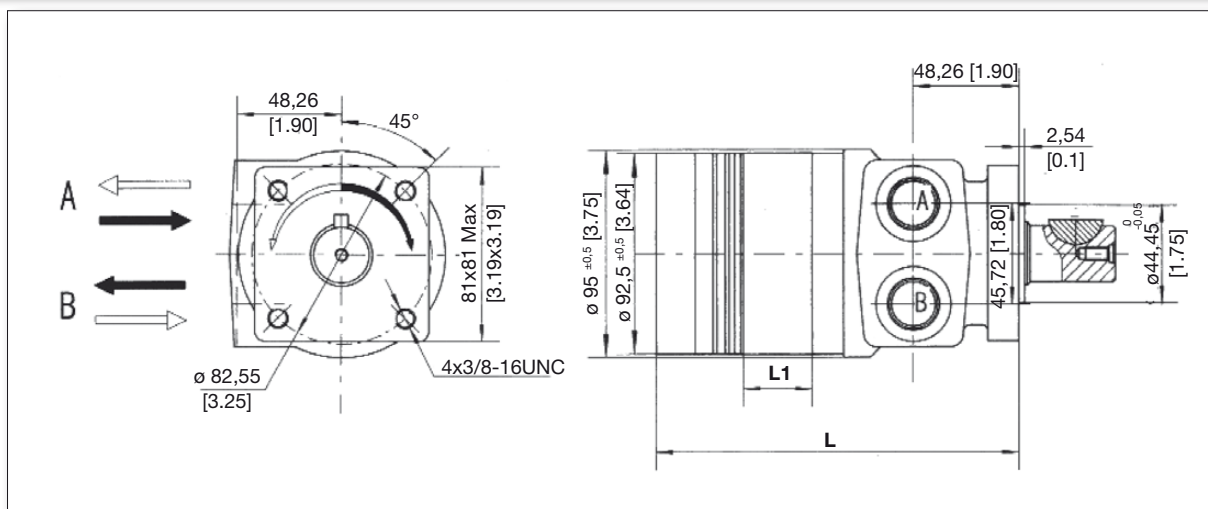

DISPLACEMENT <sup>CM<sup>3</sup>/REV</sup>	65	80	100	125	160	200	230	250	295	315	375
L1 (inches)	[0.51]	[0.63]	[0.79]	[0.98]	[1.20]	[1.50]	[1.73]	[1.97]	[2.20]	[2.44]	[2.91]
L1 (mm)	13	16	20	25	30.5	38.1	44	50	56	62	74
L (inches)	[5.87]	[5.98]	[6.14]	[6.34]	[6.56]	[6.85]	[7.09]	[7.32]	[7.56]	[7.80]	[8.27]
L (mm)	149	152	156	161	166.5	174	180	186	192	198	210
WEIGHT (lb)	[14]	[14]	[15]	[15]	[16]	[17]	[18]	[19]	[20]	[20]	[21]
WEIGHT (kg)	6.4	6.5	6.8	7	7.3	7.7	8.2	8.6	9	9.3	9.8



## DIMENSION AND MOUNTING DATA

Code: Port A, B • HS1 7/8-14 UNF • HP1 1/2-14NPTF • HD1 G1/2 • HG1 M22x1,5

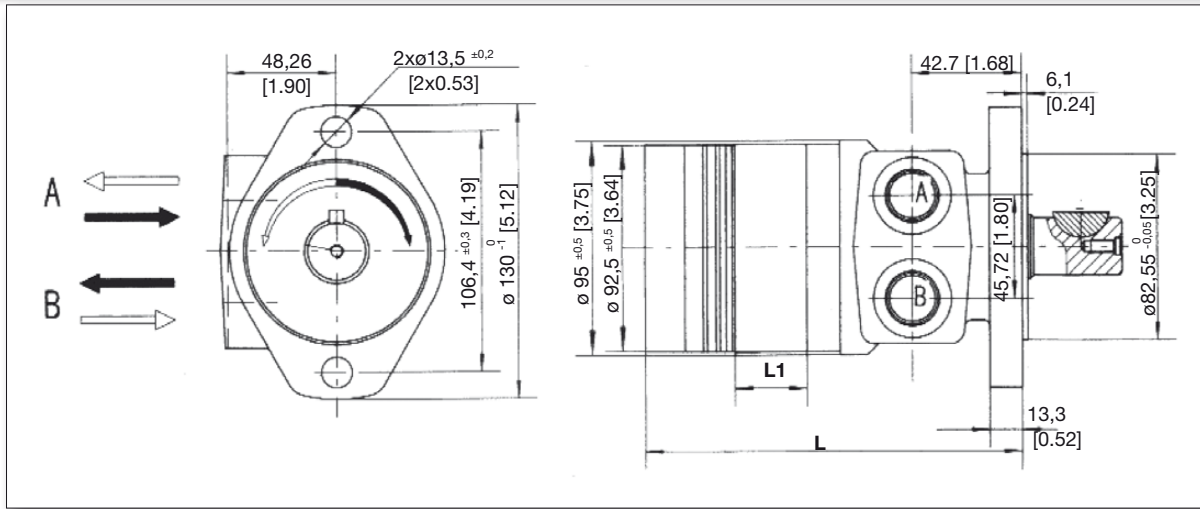

DISPLACEMENT <sup>CM</sup> /REV	65	80	100	125	160	200	230	250	295	315	375
L1 (inches)	[0.51]	[0.63]	[0.79]	[0.98]	[1.20]	[1.50]	[1.73]	[1.97]	[2.20]	[2.44]	[2.91]
L1 (mm)	13	16	20	25	30.5	38.1	44	50	56	62	74
L (inches)	[5.75]	[5.87]	[6.02]	[6.22]	[6.44]	[6.73]	[6.97]	[7.20]	[7.44]	[7.67]	[8.15]
L (mm)	146	149	153	158	163.5	171	177	183	189	195	207
WEIGHT (lb)	[14]	[14]	[15]	[15]	[16]	[17]	[18]	[19]	[20]	[20]	[21]
WEIGHT (kg)	6.4	6.5	6.8	7	7.3	7.7	8.2	8.6	9	9.3	9.8

Code: B • A, B Port M18x1,5

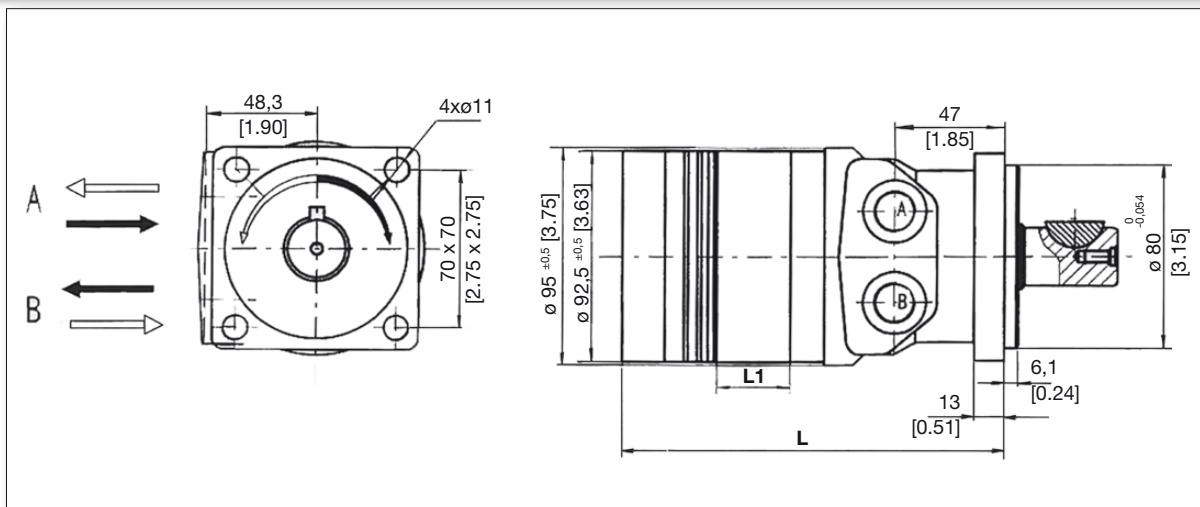

DISPLACEMENT <sup>CM</sup> /REV	65	80	100	125	160	200	230	250	295	315	375
L1 (inches)	[0.51]	[0.63]	[0.79]	[0.98]	[1.20]	[1.50]	[1.73]	[1.97]	[2.20]	[2.44]	[2.91]
L1 (mm)	13	16	20	25	30.5	38.1	44	50	56	62	74
L (inches)	[5.75]	[5.87]	[6.02]	[6.22]	[6.44]	[6.73]	[6.97]	[7.20]	[7.44]	[7.67]	[8.15]
L (mm)	146	149	153	158	163.5	171	177	183	189	195	207
WEIGHT (lb)	[14]	[14]	[15]	[15]	[16]	[17]	[18]	[19]	[20]	[20]	[21]
WEIGHT (kg)	6.4	6.5	6.8	7	7.3	7.7	8.2	8.6	9	9.3	9.8

## SHAFT EXTENSION

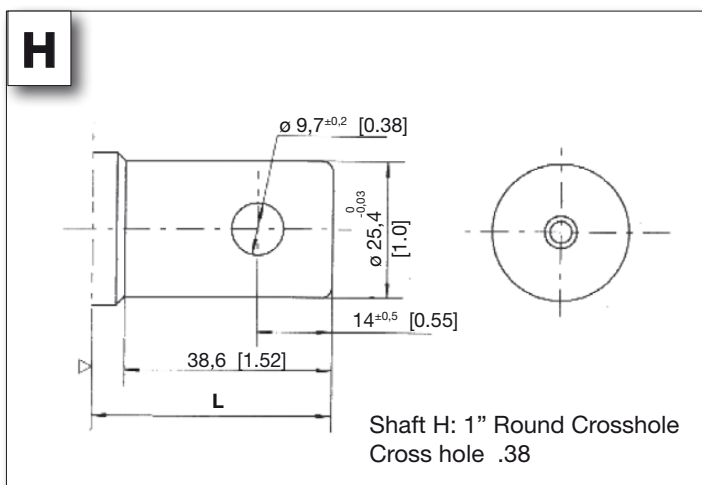
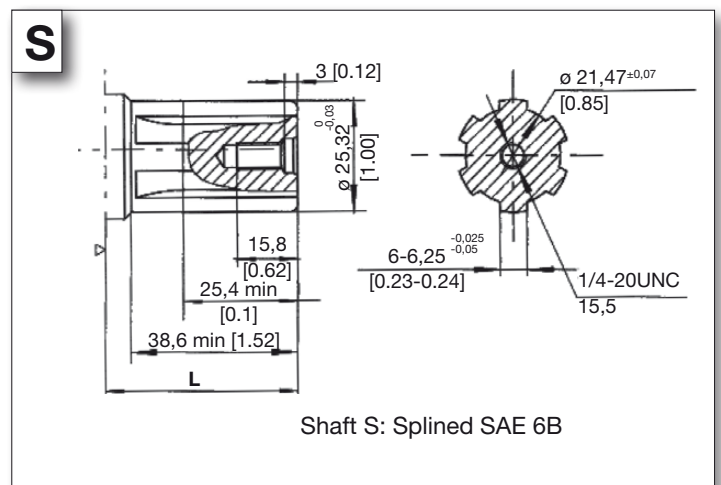
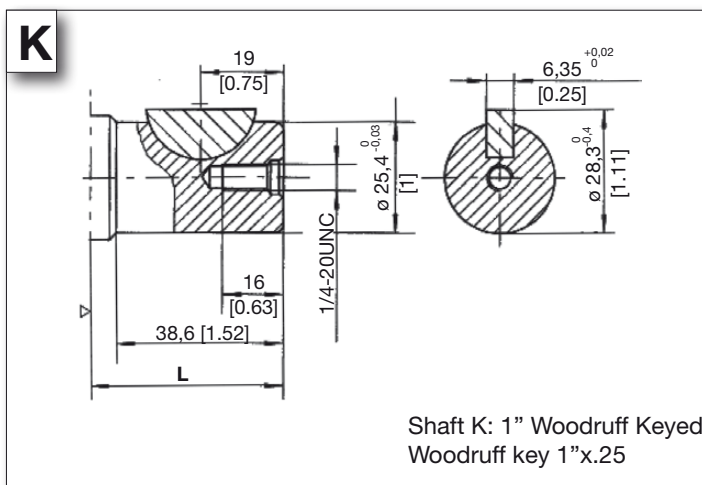
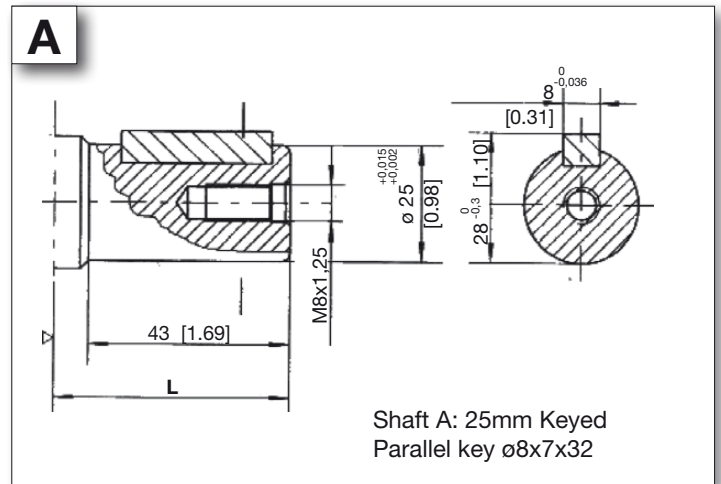
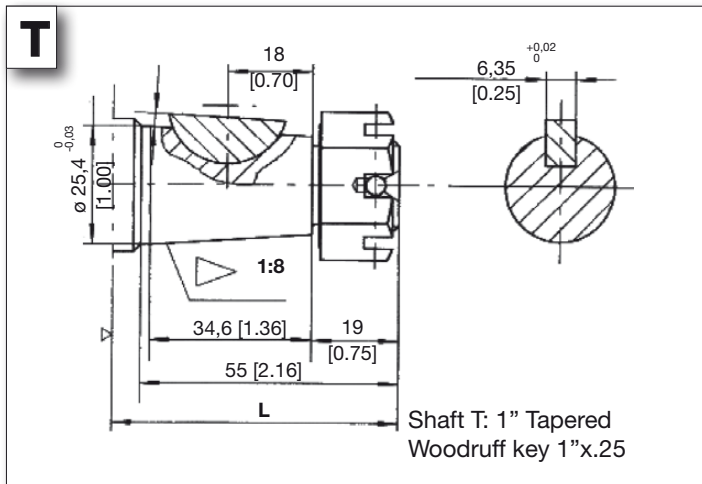

### DIMENSION L

SHAFT MOUNTING	T	A	K	S	H
WS	90.2 [3.55]	78.2 [3.08]	73.9 [2.91]	73.9 [2.91]	73.9 [2.91]
HS/HP					
H4S/H4P	62.3 [2.45]	50.4 [1.98]	44.7 [1.76]	44.7 [1.76]	44.7 [1.76]
HM					

## PERMISSIBLE SHAFT LOADS

**YME2 FOR WHEEL MOUNTING**

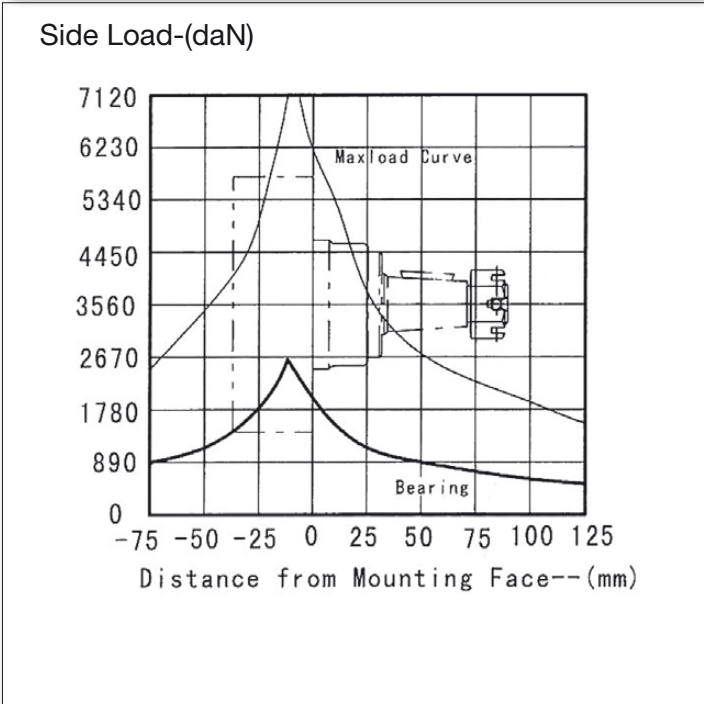

**YME2 FOR OTHER MOUNTING**

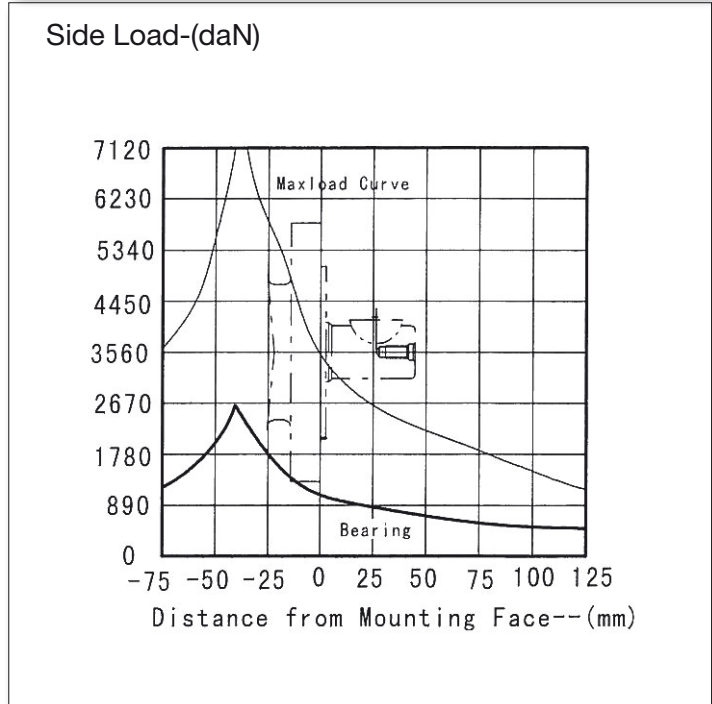

The bearing curve represents allowable bearing loads for an L10 bearing life at  $3 \times 10^6$  revolutions. The maximum load curve is defined by bearing static load capacity, this curve should not be exceeded at any time including shock loads.

## ORDERING INFORMATION

	1	2	3	4	5	6	7
YME2							

1	2		3		4		5		6	
DISP.	FLANGE		OUTPUT SHAFT		ROTATION DIRECTION		PAINT		UNUSUALLY FUNCTION	
65	WS	4-Ø13.5 Wheel-flange, pilot Ø60.3x7 Port 7/8-14 O-ring	T	SHAFT: 1" TAPERED WOODRUFF KEY 1X.25	NONE	STANDARD	00	NO PAINT	NONE	STANDARD
80	WD	4-Ø13.5 Wheel-flange, pilot Ø60.3x7 Port G 1/2	A	SHAFT: 25MM KEYED PARALLEL KEY 8X7X32	R	REVERSE			FR	FREE RUNNING
100	VM	4-Ø13.5 Wheel-flange, pilot Ø60.3x7 Port M22x1,5	K	SHAFT: 1" WOODRUFF KEYED WOODRUFF KEY 1"X.25			B	BLACK		
125	HM	2-Ø13.5 Rhomb-flange, pilot Ø82.5x2.54 Port 1/2 Manifold mount 4x5/8-18	S	SHAFT: 1"SAE 6B SPLINED					LSV	LOW SPEED VALVE
160	HS	2-Ø13.5 Rhomb-flange, pilot Ø82.5x2.54 Port 7/8-14 O-ring	H	SHAFT: 1" ROUND CROSSHOLE CROSSHOLE .38					CRS	CORROSION RESISTANT SHAFT
200	HP	2-Ø13.5 Rhomb-flange, pilot Ø82.5x2.54 Port 1/2-14 NPFT Pipe							HPS	HIGH PRESSURE SEAL
230	HD	2-Ø13.5 Rhomb-flange, pilot Ø82.5x2.54 Port G1/2							HTS	HIGH TEMP SEAL
250	HG	2-Ø13.5 Rhomb-flange, pilot Ø82.5x2.54 Port M22x1.5								
295	H4S	4-3/8-16 Square-flange, pilot Ø44.4x2.54= Port 7/8-14 O-ring								
315	H4P	4-3/8-16 Square-flange, pilot Ø44.4x2.54= Port 1/2-14 NPFT Pipe								
375	H4D	4-3/8-16 Square-flange, pilot Ø44.4x2.54= Port G1/2								
	H4G	4-3/8-16 Square-flange, pilot Ø44.4x2.54= Port M22x1.5								

### ORDERING CODE:

All options have been determined with letters, numbers or combinations. All boxes must be filled with proper codes. If specification is not in the table, please contact us with your requirements.

# YZD



## YZD SERIES HYDRAULIC BRAKE

**YZD** series brake is a wet disc hydraulic brake. The hydraulic disk brake uses spring pressure to apply the brake, and hydraulic pressure to release.

### CHARACTERISTIC FEATURES:

- YZD series incorporates an advance friction disc and spring design: For long life, low noise, high reliability
- 4 tapped drain ports, which makes this unit adaptable to many different positions and applications.
- Flange mountable to **YMP, YMR, YMS** series hydraulic motor

## YZD SERIES HYDRAULIC BRAKE

YZD series hydraulic brakes is shipped without oil and is lubricated during normal operation. Normal operation is to have the brake pressurized in the released position with the vehicle hydraulic system running. Any function which reduced the hydraulic system pressure below the release pressure of the brake will allow the springs to apply the brake.

YZD series hydraulic brakes are designed for use in heavy duty applications on vehicles in the construction, material handling, agricultural, mining, sanitation and timber industries. They are also used in a wide variety of winch and hydro-static drive system applications.

## YZD SERIES HYDRAULIC BRAKE

For optimum results the following working conditions are recommended:

1. Assembly: for YZD, that the brake be cycled before normal operation to insure proper lubrication.
2. Fluid type: mineral based-HM (GB/T763.2-87) (ISO6743/4) of HLP (DIN51524)
3. Oil Temperature range between 20 - 60C [68-180F]
4. Viscosity range: 42 ~ 74 mm<sup>2</sup>/s CSA at 40°C
5. Filtration: nominal filtration of 25 micron, ISO code 20/16
6. Maintenance: change oil after the first 50 ~ 100h; then after every 500 ~ 1000h

## MOUNTING DATA

### YZD-1

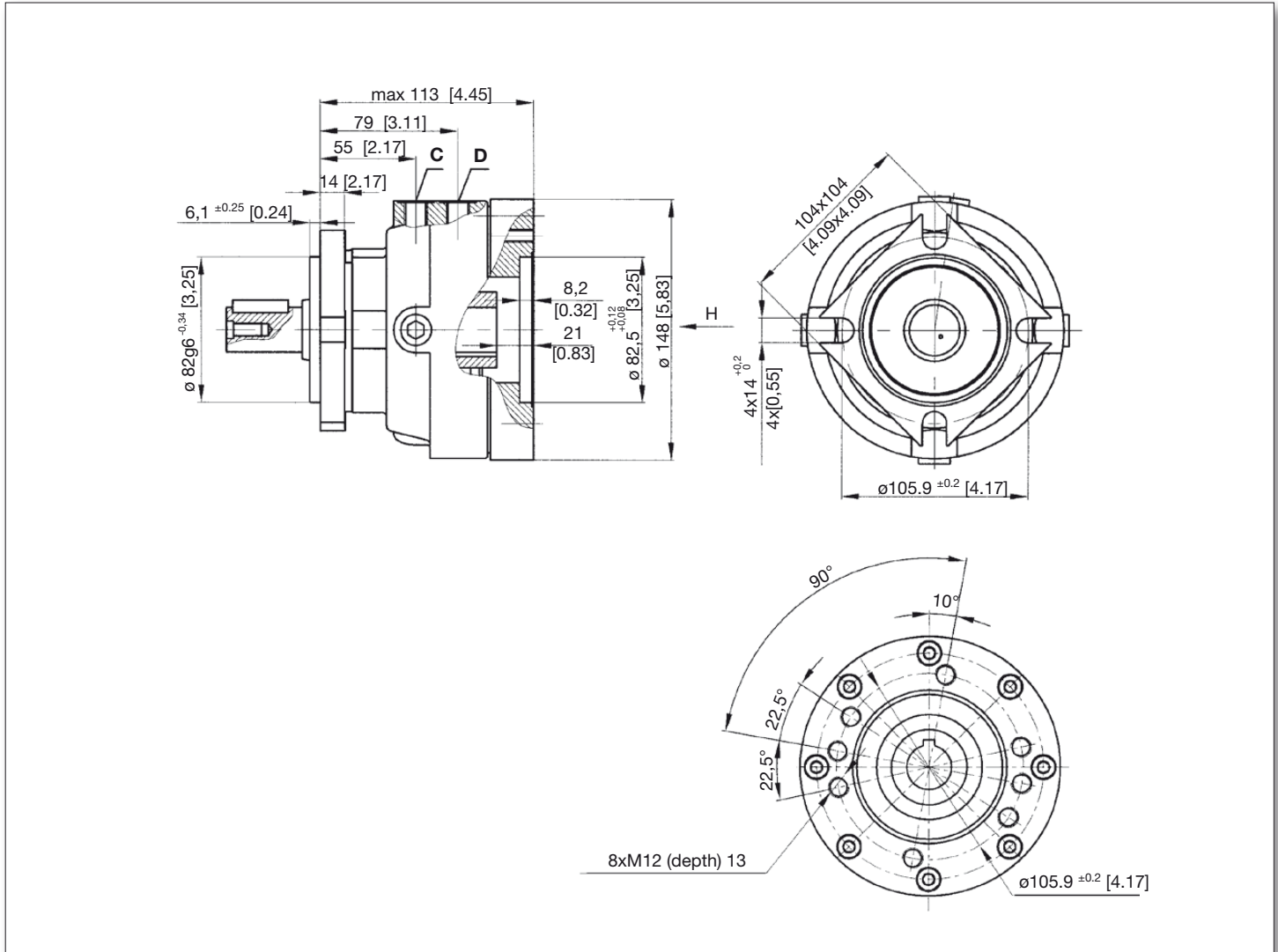

- C Drainage tap G 1/4, 9 mm depth
- D Brake release port G 1/4, 9 mm depth

## MOUNTING DATA

### YZD-2

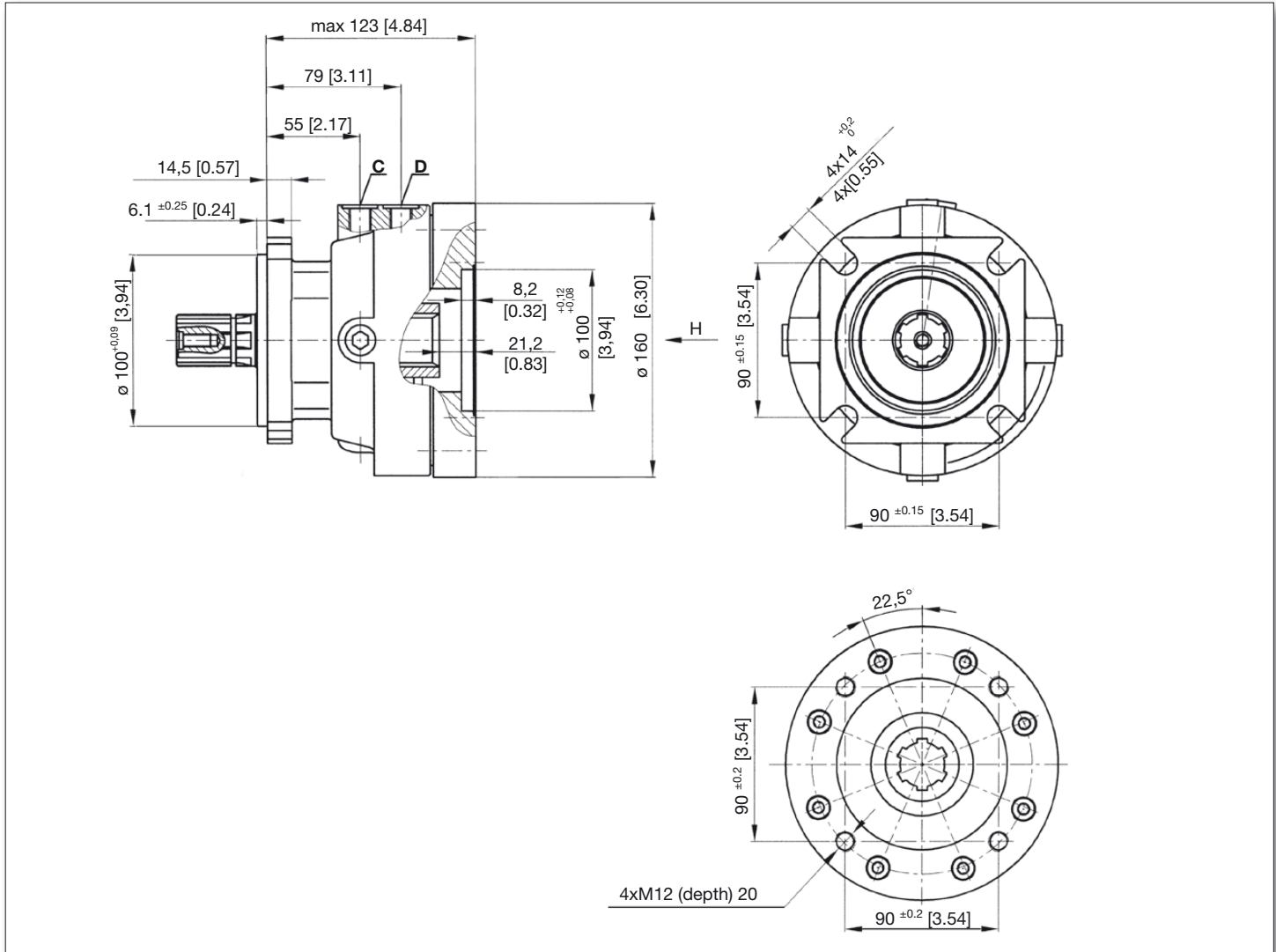

- C Drainage tap G 1/4, 9 mm depth  
 D Brake release port G 1/4, 9 mm depth

## INPUT AND OUTPUT SHAFT DATA

### INPUT SHAFTS

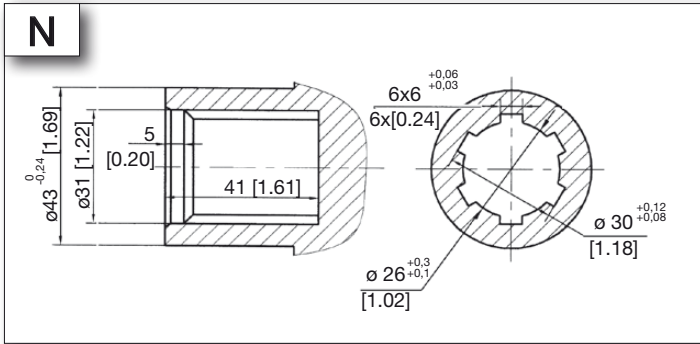
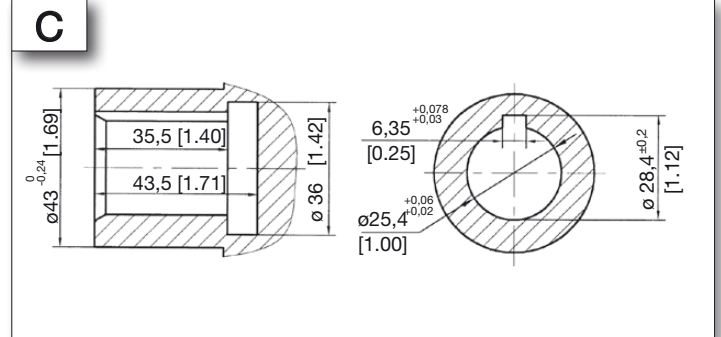
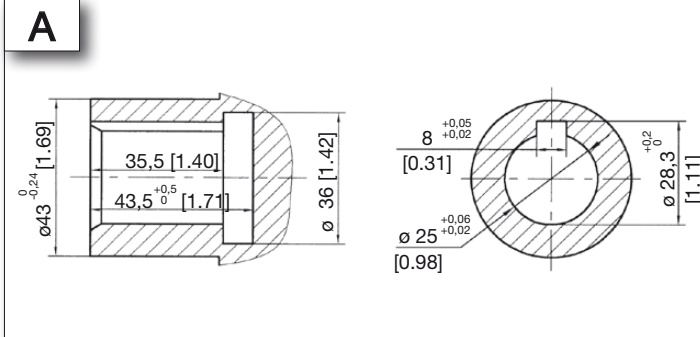

### OUTPUT SHAFTS

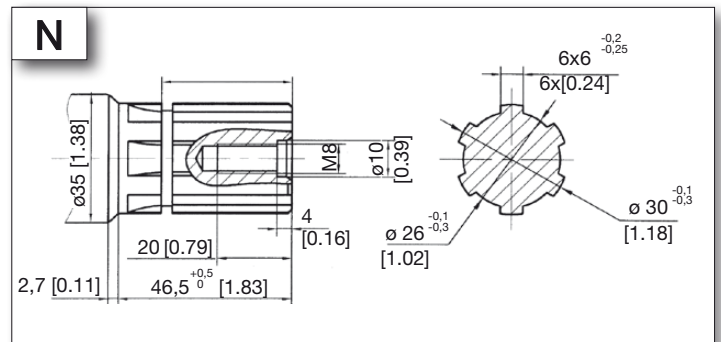
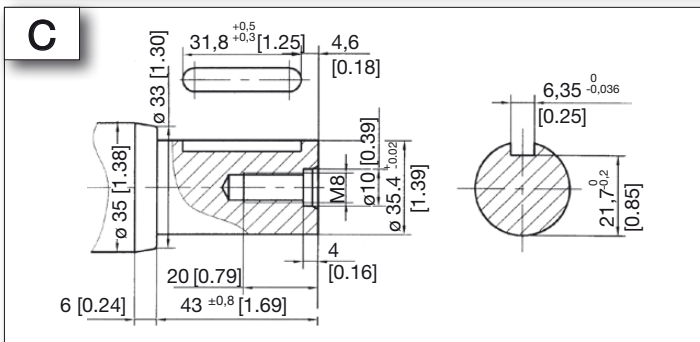
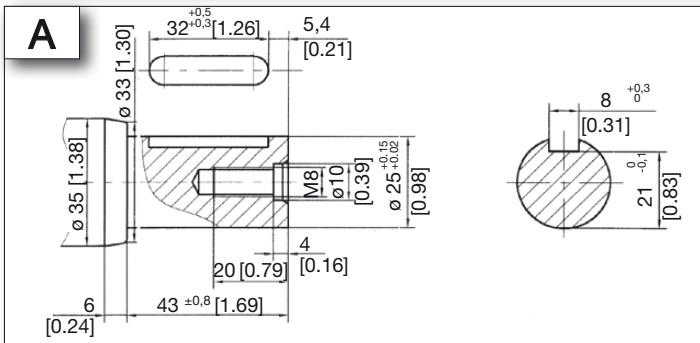



## SPECIFICATIONS

### SCHEMATIC

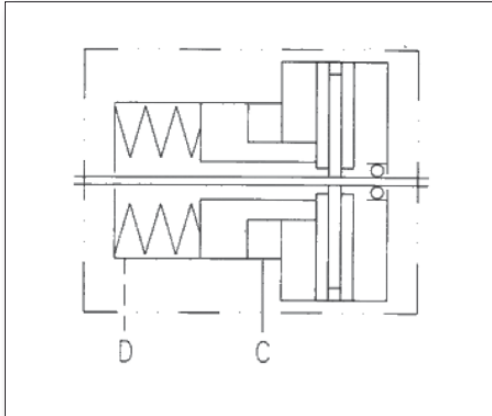

SPECIFICATION		YZD-1		YZD-2
Min static torque*	Nm [lb-in]	200-230 [1768-2034]	410 ~ 450 [3626-3979]	410 ~ 450 [3626-3979]
Min Opening Pressure	Mpa [PSI]	1.7 ~ 2.3 [246-333]		
Max Opening Pressure	Mpa [PSI]	30 [4350]		
Min oil quantity for brake releasing	cm <sup>3</sup> [in <sup>3</sup> ]	7 ~ 8 [.43-.49]		
Oil Volume	cm <sup>3</sup> [in <sup>3</sup> ]	50 ~ 120 [3-7.3]		
Max pressure in drain space	Mpa PSI	0.05 [7.2]		
Weight	Kg [Lbs]	9 [19.80]		9.5 [20.9]

\* Static torque is obtained at working pressure - 0 Mpa

## LOAD CURVES

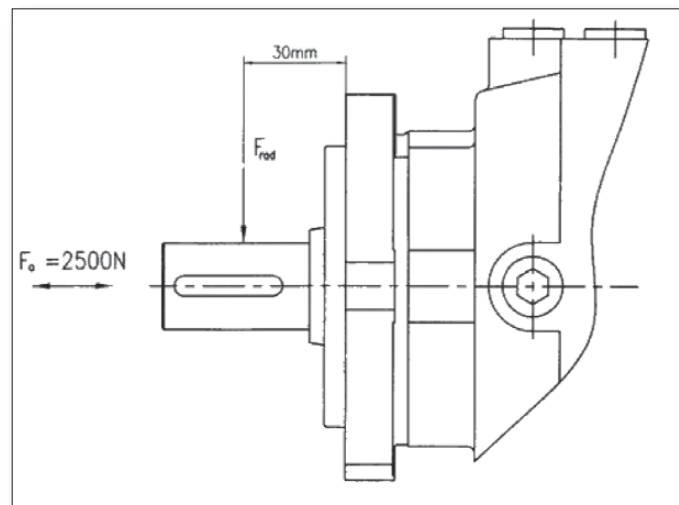
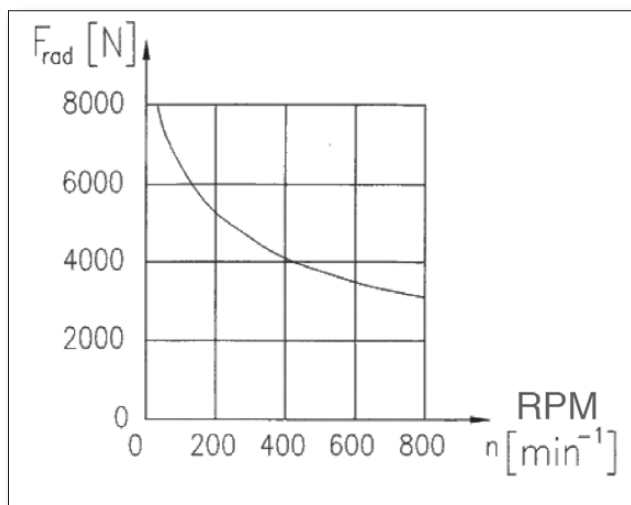

## ORDERING INFORMATION

	1	2	3	4	5	6
YZD						

1	2		3		4		5		6	
CODE.	TORQUE		INPUT SHAFT		OUTPUT SHAFT		PAINT		SPECIAL OPTIONS	
1	210	Torque: 200-230Nm 1768-2034 lb/in	A	25MM Keyed Parallel Key 8x7x32	A	25mm Keyed Parallel Key 8x7x32	B	No Paint	Omit	Standard
	430	Torque: 410-450Nm 3626-3980 lb/in	C	1" Keyed Parallel Key .25x.25x1.25	B	32mm Keyed Parallel Key 10x8x45		Black		
2	430	Torque: 410-450Nm 3626-3980 lb/in	E	Splined 1" 6b	E	Splined 1" 6b				

### ORDERING CODE:

All options have been determined with letters, numbers or combinations. All boxes must be filled with proper codes. If specification is not in the table, please contact us with your requirements.



# LSHT HYDRAULIC MOTOR DATA SHEET

Date: \_\_\_\_\_

Company \_\_\_\_\_

Contact \_\_\_\_\_ Phone \_\_\_\_\_

Machine \_\_\_\_\_ Model \_\_\_\_\_

Existing Motor Mfg \_\_\_\_\_

Code \_\_\_\_\_

Model # \_\_\_\_\_

Quantity \_\_\_\_\_

Type: GEROTOR \_\_\_\_\_ GEROLOR \_\_\_\_\_

Valve Design: SPOOL \_\_\_\_\_ DISC \_\_\_\_\_

Displacement \_\_\_\_\_ Cu in/rev

Max oil flow \_\_\_\_\_ GPM

Max working pressure \_\_\_\_\_ PSI

Nominal oil flow \_\_\_\_\_ GPM Porting \_\_\_\_\_

Nominal working pressure \_\_\_\_\_ PSI Shaft \_\_\_\_\_

Speed \_\_\_\_\_ RPM cont Mnt Flange \_\_\_\_\_

\_\_\_\_\_ RPM int

\_\_\_\_\_ RPM peak

Is a drain line available?  Yes  No

Type of flow circulation  Closed Loop  Open Loop

Free-wheeling required  Yes  No

Max torque \_\_\_\_\_ lb/in

Max fluid temp \_\_\_\_\_ F

Additional application info. \_\_\_\_\_

Duty Cycle	% of Time	Torque lb/in	% of Time	Speed Rpm	% of Time
1					
2					
3					
4					

For Internal use: \_\_\_\_\_ Date: \_\_\_\_\_

Selection \_\_\_\_\_

Reviewed by \_\_\_\_\_

Approved by \_\_\_\_\_





---

## **LIMITED ONE YEAR WARRANTY FOR HYDRAULIC MOTORS**

---

If the hydraulic motor (product) fails to function within one (1) year after the date of its original shipment, or invoice date whichever come first, due to a defect in the materials or workmanship, Young Powertech (YPT) will remedy the defect without charge to the consumer purchaser. The foregoing limited warranty does not cover failure to function caused by damage to the product while in your possession, improper installation, unreasonable use or abuse of the product, failure to provide or use of improper maintenance, failure to follow written installation and instructions.

THE REMEDIES PROVIDED IN THE ABOVE EXPRESS LIMITED WARRANTY ARE THE SOLE AND EXCLUSIVE REMEDIES AVAILABLE TO YOU. NO OTHER EXPRESS WARRANTIES ARE MADE. ALL IMPLIED WARRANTIES, INCLUDING BUT NOT LIMITED TO ANY IMPLIED WARRANTY OF MERCHANTABILITY OR FITNESS FOR A PARTICULAR PURPOSE OR USE, ARE LIMITED IN DURATION AS SET FORTH ABOVE. IN NO EVENT SHALL YPT BE LIABLE FOR ANY INCIDENTAL OR CONSEQUENTIAL DAMAGES.

Some states do not allow limitations on how long an implied warranty lasts or do not allow the exclusion or limitation of incidental or consequential damages, so the above limitations or exclusions may not apply to you. This warranty gives you specific legal rights and you may also have other rights which vary from state to state. The consumer-purchaser must maintain proof of purchase and shipment date of the product to prove the date of purchase and shipment in the unlikely event of a warranty claim.

In order to obtain a return authorization number you must contact Young Powertech Inc. at 610-558-0760 prior to shipping. The customer will be required to ship only the defective parts, freight pre-paid to :

**Young Powertech Inc  
3060 Plaza Dr.  
Unit 107  
Garnet Valley, PA 19061**

Young Powertech Inc, will repair or replace any part found defective and return the unit prepaid by ground shipment to the customer.

In the event that the unit is not found to have a defect the customer will be charged an inspection fee and the unit will be returned freight collect to the customer.





Young Powertech  
3060 Plaza Drive # 107  
Garnet Valley PA 19060  
Tel: (610) 558-0760  
Fax: (610) 558-0762  
e-mail: [info@youngpowertech.com](mailto:info@youngpowertech.com)

YPT-001-2012-8