



LAMIRA™ NEBULIZER SYSTEM

INSTRUCTIONS FOR USE



▲ WARNING

Read and understand these **Instructions For Use** and all safety precautions it contains. Improper use can cause serious or fatal injury or illness.

▲ WARNING

Read and understand the **Prescribing Information** leaflet for information and warnings for the drug ARIKAYCE.

For use only with:

ARIKAYCE®
(amikacin liposome
inhalation suspension)

Limited Population*



Prescription Only

Assembly required. ARIKAYCE vials packaged separately.
*See the full prescribing information for ARIKAYCE for information about the limited population.

Table of Contents

| | |
|--|----|
| A. Introduction | 1 |
| B. Safety Precautions | 2 |
| C. Getting Started | 3 |
| D. Using Batteries or the A/C Power Supply | 4 |
| E. Maintaining Your Lamira | 5 |
| F. Cleaning Your Lamira | 6 |
| G. Disinfecting Your Lamira | 9 |
| H. Assembling your Lamira Handset | 10 |
| I. Taking ARIKAYCE | 13 |
| J. Frequently Asked Questions | 16 |
| K. Troubleshooting | 17 |
| L. Specifications | 19 |

Introduction

The Lamira™ Nebulizer System (Lamira) is a battery operated electronic nebulizer, which vibrates and forces liquid ARIKAYCE through thousands of small holes to form an aerosol mist for inhalation.

These Instructions for Use contain information and safety precautions for the Lamira nebulizer that is made just for the medicine ARIKAYCE® (amikacin liposome inhalation suspension). **Do not** use any other medicine in the Lamira nebulizer.

Warning

Before using your Lamira nebulizer, read and understand all the Instructions for Use and save them for future reference. If you do not understand any part of these directions, contact the Arikares Support Program at 1-833-ARIKARE (1-833-274-5273) before using the Lamira nebulizer.

To reduce the risk of infection, illness, or injury from contamination or improper use, it is important to complete the following 2 steps:

- 1) Rinse and clean the Handset including the Aerosol Head before first use and right after each use.** (see Section F) Do not wash the Controller, Connection Cord, or A/C Power Supply. Use clear liquid soap made for washing dishes to clean the Handset including the Aerosol Head. Do not use liquid dish soaps that are white or antibacterial liquid dish soaps because these may contain additives harmful to the Aerosol Head.
- 2) Disinfect the Handset including the Aerosol Head every day (see Section G).**

Take special note of all safety precautions marked **Danger and Warning**.

Indications for use

Limited by Federal Law for use only with ARIKAYCE.

Read all dangers and warnings before using.

Danger

To reduce the risk of fatal injury from electrocution:

- **Do not** place or store the Lamira Nebulizer System near water or other liquid such as bathtub or sink. **Do not** place or drop into water or other liquid. **Do not** use while bathing.
- **Do not** reach for the Lamira Nebulizer System if it has fallen into water or other liquid. Unplug right away. Pick up the Lamira only after it has been unplugged.

Warning

To reduce the risk of serious injury:

- The Lamira Nebulizer Handset (Handset) is for single patient use. **Do not** share your Handset with other people.
- The Handset is made just for ARIKAYCE. Never use other medicine in the Handset. Using other medicine in the Lamira nebulizer can result in severe injury or death.
- Read, understand and follow all warnings and instructions in these Instructions for Use before using the Lamira nebulizer.
- To reduce the risk of fire, burns and damage or malfunction of the Controller:
 - ✓ **Do not** overload wall outlets or use extension cords.
 - ✓ Keep all electrical cords away from heated surfaces.
 - ✓ **Do not** spray liquids onto the housing of the Controller (Controller). (See Section C: Getting Started) Liquid may cause damage to the electrical parts and could lead to a malfunction. If liquids enter the Controller, contact the Arikares Support Program at 1-833-ARIKARE (1-833-274-5273).
 - ✓ **Do not** insert any object into any opening on the Lamira.
 - ✓ **Do not** operate where oxygen is being given in a closed environment such as an oxygen tent.
- Always unplug the Lamira right after using and before cleaning.
- Before use, check your Lamira for proper assembly. All parts must be connected and firmly in place. Use of an improperly assembled Lamira could decrease or stop the effectiveness of your treatment.
- Use only adapters and accessories that are made for the Lamira. Use of unapproved adapters or accessories can lead to improper administration, injury, leading to damage to the Controller.
- Never substitute the Handset for any other eFlow® Technology Handset such as Altera®, eRapid® or any other eFlow®. Never use the Lamira Aerosol Head (Aerosol Head) in any other eFlow® Technology Handset. This Aerosol Head has unique performance characteristics for ARIKAYCE.
- Never operate the Controller if it is improperly or incompletely assembled or damaged. See Section K: Troubleshooting for more information about alerts that appear when the Lamira is improperly assembled or might be damaged.
- Never operate the Lamira if:
 - ✓ It has damaged cords or plugs,
 - ✓ it is not working properly,
 - ✓ it has been dropped or damaged,
 - ✓ the Controller has been exposed to liquids

- To reduce the risk of infection, illness, or injury from contamination, clean and dry all parts of the Handset after each use. Follow the instructions in Section E to maintain and clean the Lamira.
- Cleaning the Handset properly will help prevent the Aerosol Head from clogging. **Replace the Aerosol Head with a new one after 7 uses.** If the Aerosol Head becomes clogged, the aerosol mist will be reduced, which may increase your inhalation time of therapy. If clogging occurs, use the instructions in Section F to clean the Aerosol Head.
- Cleaning the Handset and Aerosol Head only removes the medicine and saliva. To reduce the risk of serious or fatal illness caused by contamination of the Handset, you must also disinfect the Handset and Aerosol Head after every cleaning. See Section G for disinfection instructions.
- The Lamira contains small parts that may become a choking hazard to small children. The Lamira Connection Cord (Connection Cord) also may become a strangulation hazard.
- **Do Not** allow pets, for example dogs or rodents, near the cables.
- Keep the Lamira out of reach of children.
- Keep the Handset level when in use. Excessive tilting can cause the Controller to shut off leaving unused ARIKAYCE in the Medication Reservoir and resulting in incomplete dosing.
- Closely supervise use when the Lamira is used near children or the physically or mentally impaired.
- **Do not** use your Lamira while driving or in any situation which takes away your full attention.
- If the Lamira has been damaged or is not operating properly, contact the Arikares Support Program at 1-833-ARIKARE (1-833-274-5273).
- **Do not** take the Controller apart at any time. There are no user serviceable parts inside the Controller. Contact the Arikares Support Program at 1-833-ARIKARE (1-833-274-5273) for all Controller service needs.
- **Do not** modify this equipment without authorization from the manufacturer.
- **Do not** use the device in areas exposed to elevated electromagnetic or electrical radiation such as a MRI scanner or high frequency surgical equipment.
- **Do not** place near other medical devices during operation unless both devices are monitored constantly to make sure both are operating properly.
- **Do not** use within 12 inches (30 cm) of portable wireless communication devices such as cell phones or antenna cables or external antennas.
- **Do not** use near airplane or train control systems. Do not use aboard aircraft.
- **Do not** use the nebulizer near anti-theft systems and Radio Frequency Identification (RFID) readers, which are used in a wide variety of settings, including stores, libraries, and hospitals. Do not power on the nebulizer when passing through security screening or theft protection (RFID) systems at entrances or exits of stores, libraries or hospitals. Note that some entrance and exit security systems are not visible.

Technical electromagnetic compatibility data is available in table form upon request from PARI Pharma GmbH or on the Internet at <https://www.pari.com/fileadmin/Electromagnetic-compatibility-4.pdf>

Step C1: Gather your dosing supplies:

- Clear liquid soap for cleaning the Handset
- Distilled water for disinfecting the Handset
- The ARIKAYCE 28 day drug kit will contain the following:
 - 28 vials of ARIKAYCE (1 vial to be used each day for 28 days)
 - 4 Lamira Aerosol Heads (1 Aerosol Head to be used for 7 days and then replaced)
 - 1 Lamira Handset (to be used for 28 days until the next ARIKAYCE drug box arrives)
 - 1 ARIKAYCE Quick Start Guide
 - 1 Instructions For Use Insert
 - 1 Full Prescribing Information Insert

Step C2: Check your Lamira Nebulizer System package to make sure you have the items shown below. Note that the package contains a Handset that should be set aside as a spare. If anything looks damaged, contact the Arikares Support Program at 1-833-ARIKARE (1-833-274-5273).

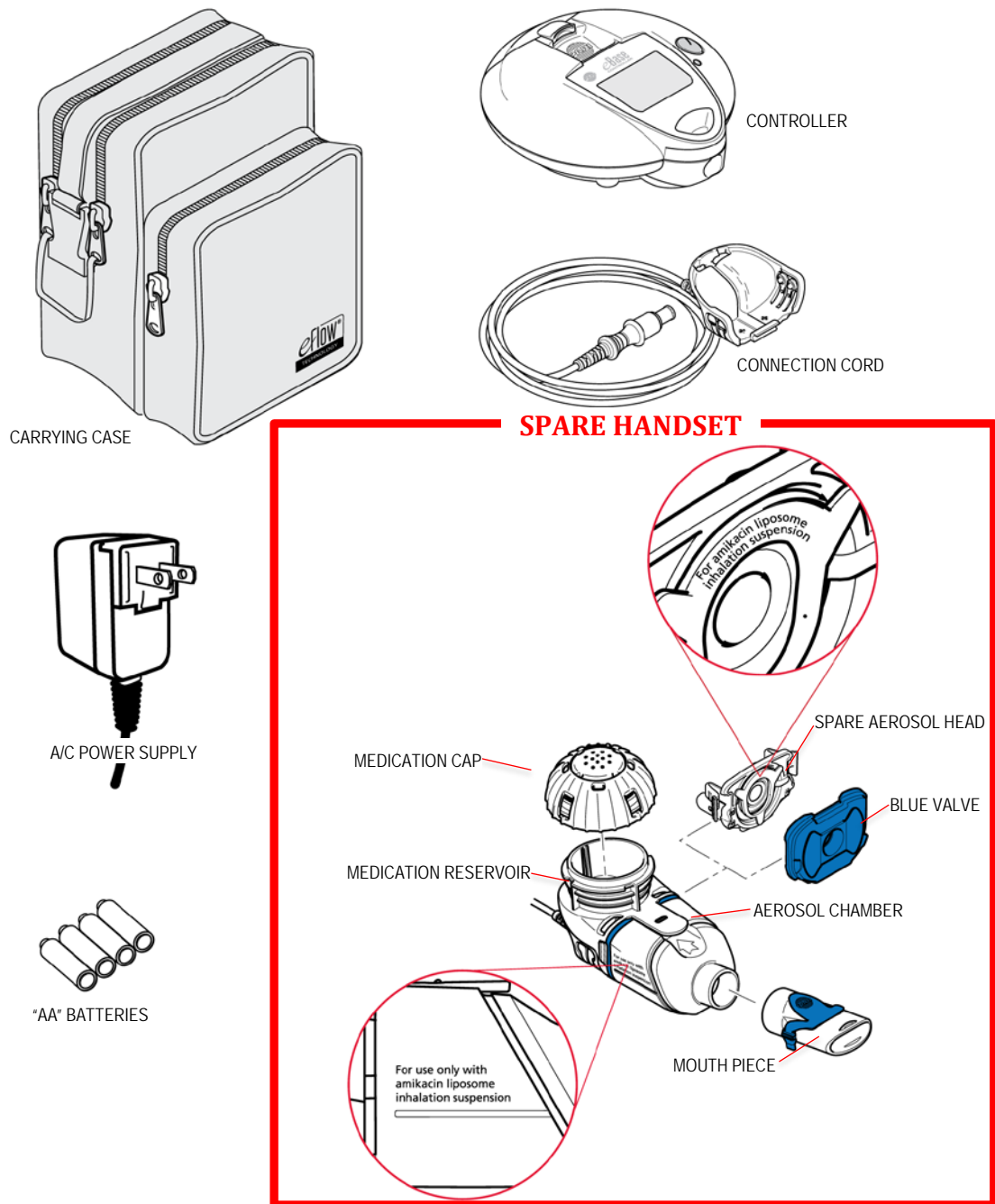

D

Using Batteries or the A/C Power Supply

The Lamira is made to be used with “AA” batteries or with the A/C Power Supply.

Using Batteries: Four (4) high quality “AA” batteries should provide 2 hours of total use.

Step D1: **Open the Battery Door** on the Controller by placing your thumb on the tab of the Battery Door and firmly pulling the tab to open the Door (D-1).

Step D2: **Load the Batteries.** Each Battery Chamber has a small figure that shows the proper position of each battery (D-2). Using the battery “tips” as guides and starting left-to-right for each row, insert the batteries: Tip Out, Tip In, Tip Out, Tip In.

Close the Battery Door. To close the Battery Door, push it closed until you hear it “click” into place.

NOTE: Rechargeable and Disposable Batteries have differences in storage life and output. If you plan to store the Controller for more than 30 days, it is recommended to remove the batteries to reduce the risk of battery leakage.

If you choose not to use the A/C Power Supply, you should have an extra battery set with you at all times.

Using the A/C power supply: The A/C Power Supply will automatically adjust to the incoming voltage and will power the Controller with or without installed batteries. It can be used worldwide, but requires “Plug Converters” for use outside the USA.

Step D3: **Plug the A/C Power Supply into the Controller.** To connect the A/C Power Supply to the Controller, place the Controller on a clean, flat, stable surface. The plug inlet port is located on the underside of the gray Battery Door. Push the round end of the A/C Power Supply plug into the plug inlet port (D-3). **Do not** try to insert the A/C Power Supply into the front of the Controller.

Step D4: **Plug the A/C Power Supply into the wall outlet.** Note that the A/C Power Supply will not charge the batteries in the Controller.

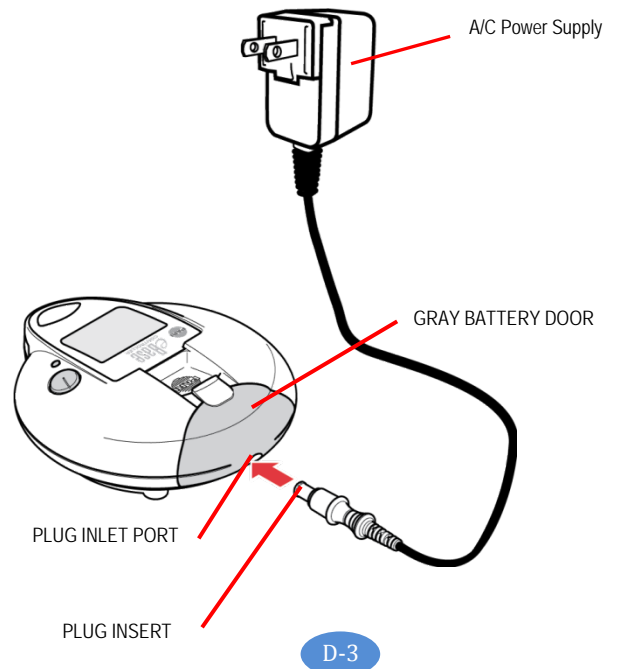
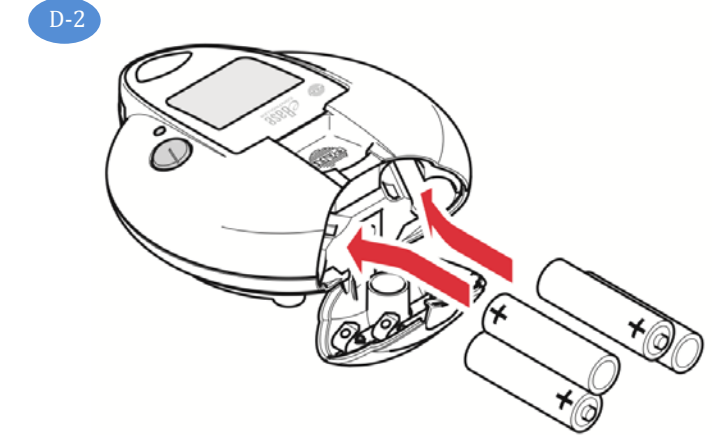
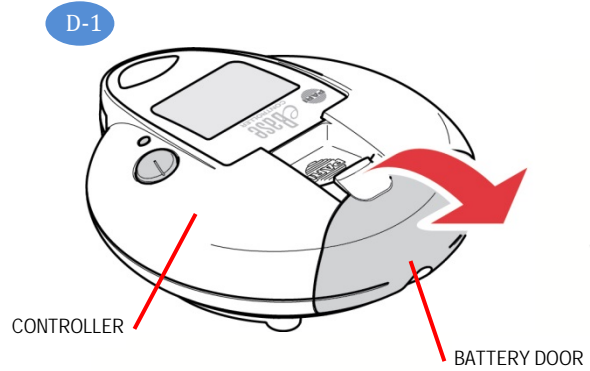

Warning

To reduce the risk of infection, illness, or injury from contamination or improper use, it is important to complete the following 2 steps:

- 1) **Rinse and clean the Handset including the Aerosol Head before first use and right after each use.** (see Section F) Do not wash the Controller, Connection Cord, or A/C Power Supply. Use clear liquid soap made for washing dishes to clean the Handset. Do not use liquid dish soaps that are white or antibacterial liquid dish soaps because these may contain additives harmful to the Aerosol Head.
- 2) **Disinfect the Handset every day** (see Section G).

Caution

- Do not put the Handset or the Aerosol Head in the microwave oven.
- Do not try to clean the Handset or Aerosol Head in a dishwasher.
- Do not try to clean the Handset or the Aerosol Head with brushes or abrasives.

Handset Maintenance Summary (see the next page for complete instructions)

| Instruction | When | Parts cleaned | Method | How Long | Comments |
|-------------|---------------------------------------|---|--|------------------------|---|
| Wipe | After each use | <ul style="list-style-type: none"> • Medication Reservoir and Aerosol Chamber • Mouthpiece | Wipe with clean disposable paper towel. | 1 second per part | Wipe to remove residual medicine and then dispose of paper towel in trash with solid waste. |
| Rinse | Prior to first use and after each use | <ul style="list-style-type: none"> • Aerosol Head • Medication Cap and Seal • Blue Valve • Medication Reservoir and Aerosol Chamber • Mouthpiece | Warm running tap water. | 10 seconds | Rinse each side of the Aerosol Head for 10 seconds. |
| Clean | Prior to first use and after each use | <ul style="list-style-type: none"> • Aerosol Head • Medication Cap and Seal • Blue Valve • Medication Reservoir and Aerosol Chamber • Mouthpiece | Soak each piece in warm soapy water. While soaking swish or shake each piece. | 5 minutes | Use 3 to 5 drops of clear liquid dish soap in a bowl with enough warm water to cover all pieces. Soak longer if Handset has dried or if visibly dirty. |
| Rinse | Prior to first use and after each use | <ul style="list-style-type: none"> • Aerosol Head • Medication Cap and Seal • Blue Valve • Medication Reservoir and Aerosol Chamber • Mouthpiece | Warm running tap water. | Until soap is removed. | Check each part and soak for another 5 minutes if any part looks dirty. |
| Disinfect | Prior to first use and after each use | <ul style="list-style-type: none"> • Aerosol Head • Medication Cap and Seal • Blue Valve • Medication Reservoir and Aerosol Chamber • Mouthpiece | Boil in distilled water. | 5 minutes | Air-dry in a dust-free environment. |

F

Cleaning Your Lamira

⚠ WARNING Your Handset including the Aerosol Head is not sterile. Contamination and moisture may cause the growth of bacteria and the Aerosol Head can be affected by ARIKAYCE left over in it. It is important to rinse, clean, and disinfect your Handset including the Aerosol Head before first use and right after every use. If your Handset or Aerosol Head looks dirty, soak the parts in soapy water for longer than 5 minutes. Do not place the Handset or the Aerosol Head in a dishwasher.

Cleaning your Handset

Step F1: Disconnect your Handset from the Connection Cord (F-1).

F-1

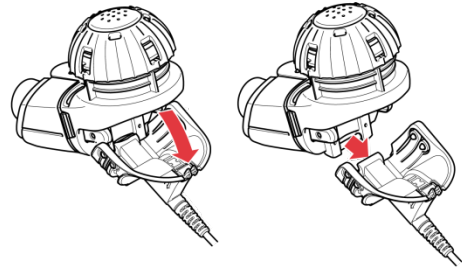

Step F2: Remove the Medication Cap by turning counterclockwise and pulling straight up (F-2).

F-2

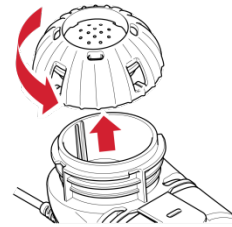

Step F3: Remove the Mouthpiece from the Aerosol Chamber by pulling straight off (F-3). The Blue Flap must still be attached to the mouthpiece as shown in the picture.

F-3

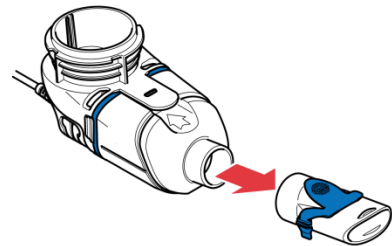

Step F4: Gently pull up on the tab to open the Handset and remove the Blue Valve (F-4).

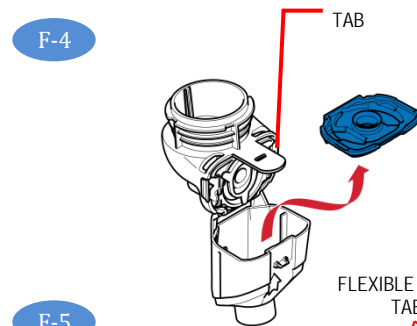

Step F5: Being careful to touch only the plastic outer ring of the Aerosol Head, press the 2 flexible plastic tabs on the side of the Aerosol Head towards each other and remove (F-5). After the Aerosol Head has been used 7 times, throw away (dispose of) and replace with a new one.

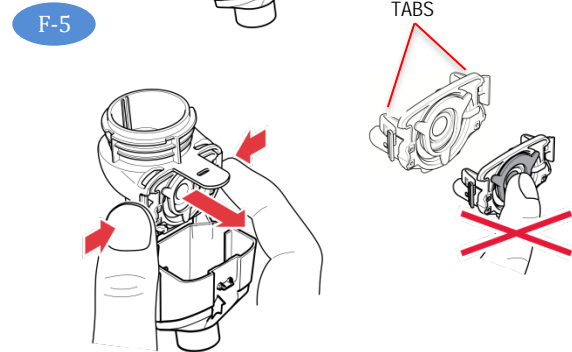

Do not touch the center silver part of the Aerosol Head.

Step F6: Gently wipe away any drops of medicine from the medication reservoir (F-6a), aerosol chamber (F-6b) and mouthpiece (F-6c) before rinsing to reduce antibiotics added to water systems.

Use only plain, dry paper towels or wipes. Do not use towels or wipes that have any chemicals added to them such as alcohol, lotion, or baby wipes.

Be careful not to harm the parts.

Do not wipe the Aerosol Head.

Throw away paper towels by disposing in trash with solid waste.

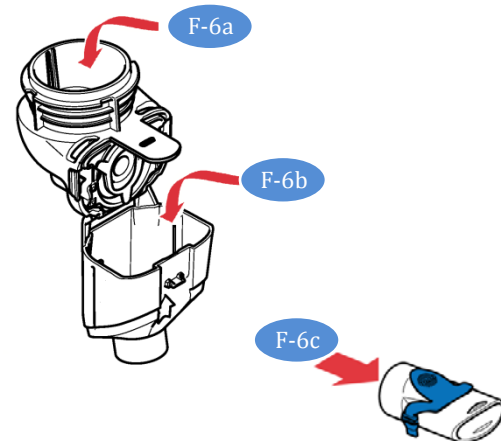

Step F7: Rinse each of the parts under warm running tap water for 10 seconds. Pay special attention to rinsing the Aerosol Head and rinse each side of the Aerosol Head for 10 seconds (F-7). Thorough rinsing of both sides of the Aerosol Head helps to prevent clogging and makes sure the Aerosol Head works properly. Never use a brush or any other object to clean the Aerosol Head.

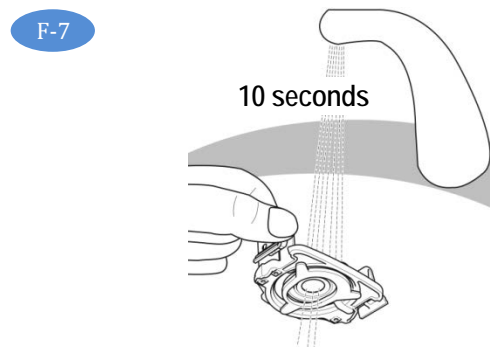

F**Cleaning Your Lamira (continued)**

Step F8: Clean all Handset parts by adding a few drops of clear liquid dish soap and warm tap water to a clean tub or bowl. Cover the Handset parts in the warm soapy water and soak for 5 minutes, shaking them periodically (F-8).

F-8

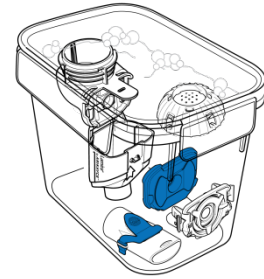

Step F9: Rinse all parts thoroughly under warm running tap water to remove soap (F-9). Check each part and soak for another 5 minutes if any of the parts look dirty. After all parts are cleaned and free from soap, disinfect your Handset.

F-9

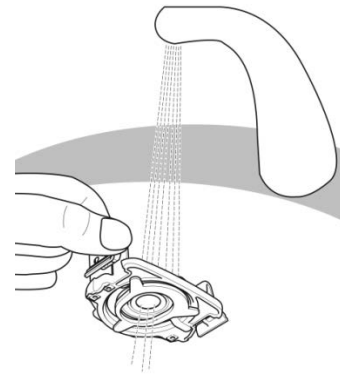

Step F10: Disinfect the Handset including the Aerosol Head after cleaning. In addition to cleaning ARIKAYCE from your Handset, you must also disinfect your Handset to remove bacteria and avoid infection. See Section G for instructions on how to disinfect your Lamira Handset.

Cleaning your Controller and Connection Cord

Step F11: To reduce the risk of electric shock, disconnect all connections before cleaning. Switch off the Controller. Remove the Connection Cord and A/C Power Supply cord from the Controller.

Step F12: Clean the Controller housing and Connection Cord as needed with a soft, clean, damp cloth. Do not place the Controller unit under water or allow liquid to get inside the Controller. Make sure moisture from the cloth does not enter the Controller.

Caution Never let the Controller come in contact with water or cleaning agents. If liquid does get into the Controller, contact the **Arikares Support Program**.

G

Disinfecting Your Lamira

Warning To prevent serious or fatal illness or injury caused by contamination, disinfect your Handset including the Aerosol Head at the end of every day.

Step G1: Clean your Handset right after every use with soapy water as described in Section F.

Step G2: Disinfect your Handset at the end of every day by boiling in distilled water.

To disinfect with boiling water, boil the Handset parts, including the Aerosol Head, in a clean pot of distilled water for a full 5 minutes.

Step G3: Air dry on a lint-free towel (G-3). After the parts are completely dry, wrap them in a lint-free towel for storage. Reassemble just before taking your next treatment. This is to make sure the Blue Valve will not become damaged.

G-3

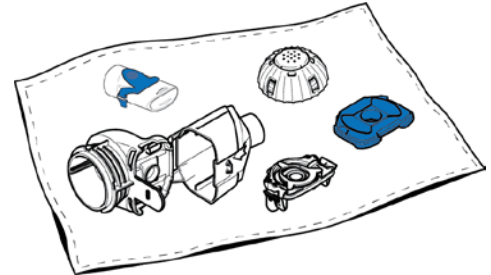

Warning

Your Handset including the Aerosol Head is not sterile. Clean and disinfect your Handset before the first time you use it and after each use (See Sections F and G). Inspect all parts to make sure they are cleaned and are not visibly damaged. Do not use dirty or damaged parts.

Step H1: Clean and Disinfect your Handset before the first time you use it. See Sections F and G.

Step H2: Wash your hands with soap and water and dry them well (H-2).

Step H3: Open the Handset. The Medication Reservoir and the Aerosol Chamber are attached using a "hinge". First, gently pull up on the tab of the hinge (H-3). This will release the Medication Reservoir (H-3). This will release the Aerosol Chamber so that you may open it.

Step H4: Insert the Blue Valve on top of the Aerosol Chamber (H-4). Make sure the 2 valve flaps are positioned down as shown in H-4a. **Do not** push the Blue Valve inside of the Aerosol Chamber. The Blue Valve should be placed on top of the Aerosol Chamber.

Clean and disinfect your Handset before the first time you use it.

H-2

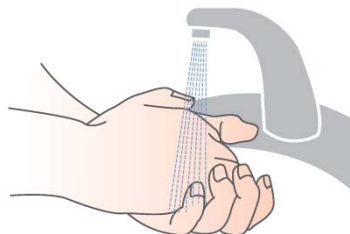

H-3

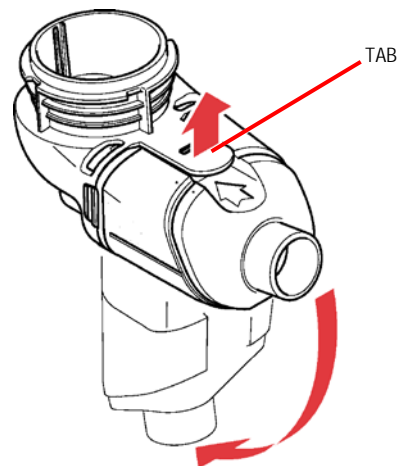

H-4

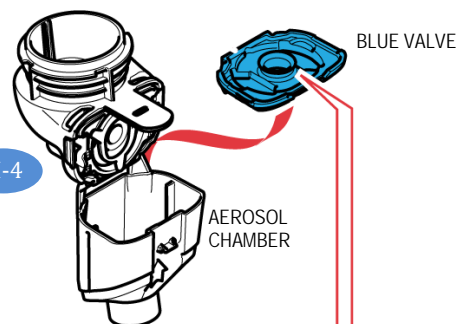

VALVE FLAPS

H-4a

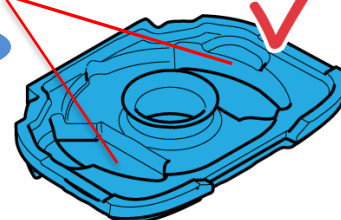

VALVE FLAP

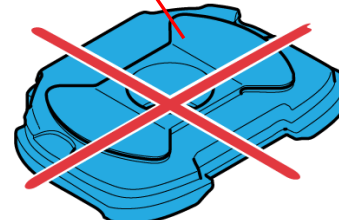

Step H5: Insert the Aerosol Head

Note: It is important that you do not touch the silver part of the Aerosol Head at any time during assembly. (H-5a)

H-5a

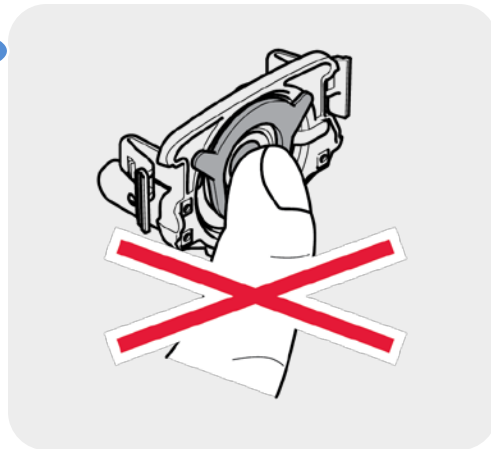

Check to make sure the Aerosol Head is labeled "For Amikacin Liposome Inhalation Suspension". Do not use other eFlow Technology Aerosol Heads in the Lamira. (H-5b).

H-5b

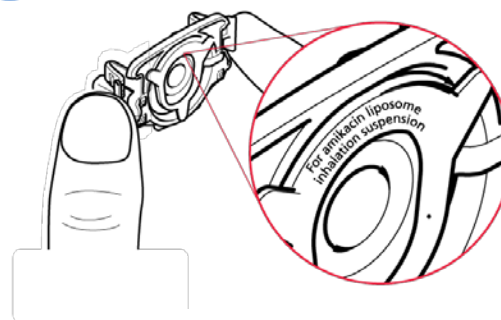

Carefully grasp the Aerosol Head by the 2 flexible plastic tabs on each side of the Aerosol Head. Turn the Aerosol Head so that "For Amikacin Liposome Inhalation Suspension" is facing toward you and is at the top of the Aerosol Head (H-5b).

H-5c

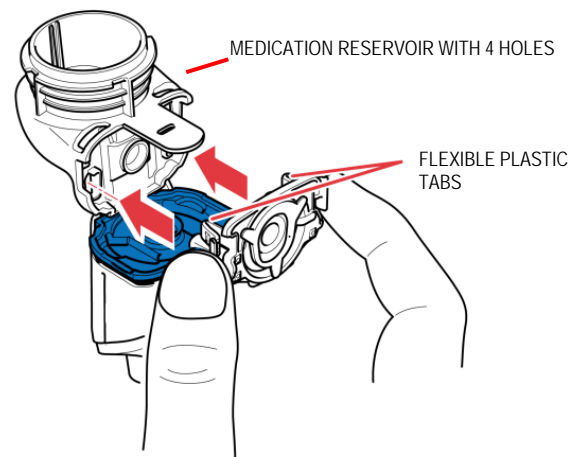

Squeeze the two flexible plastic tabs together while inserting the metal arms and flexible plastic tabs into the Medication Reservoir (H-5c). You should feel the flexible plastic tabs "grab" as you insert it.

H-6

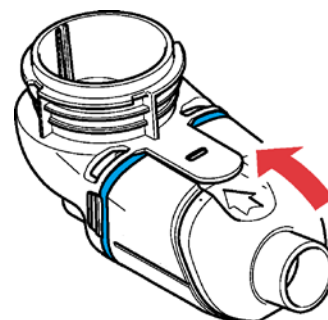

Step H6: Close your Handset by pushing the Aerosol Chamber together with the Medication Reservoir until you hear a "snap" (H-6). If you do not hear a snap, open the Handset and check that the Blue Valve is seated properly (See Step H-4).

Step H7: Attach Mouthpiece to your Handset. Make sure the Blue Flap is facing up (H-7) and is pressed in the slot on the Mouthpiece. Push the Mouthpiece straight onto the Handset. Make sure the Mouthpiece stays attached to the Handset during treatment.

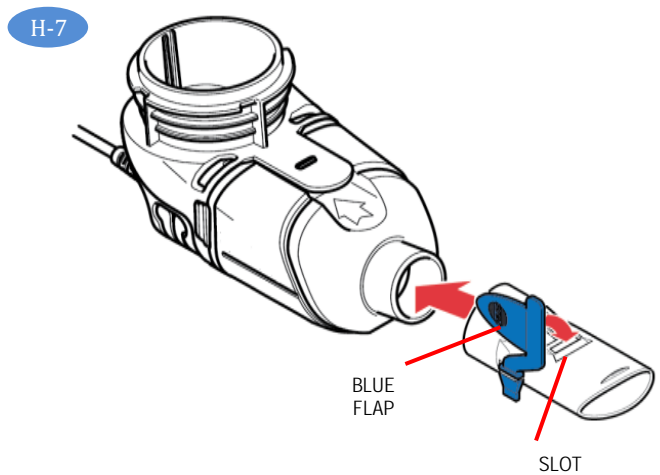

Step H8: Attach the Connection Cord by lining up the bottom of the Connector with the bottom of the Handset (H-8a) and pushing the Connection Cord upward against the rear underside of the Handset (H-8b) until you hear the parts snap together.

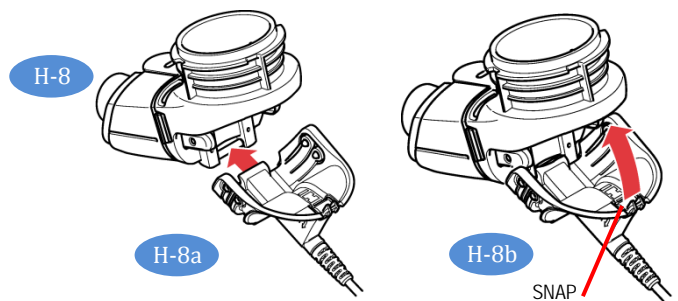

Step H9: Connect the Connection Cord to the Controller. Push the round end of the Connection Cord into the plug inlet port located under the digital display (H-9). Place the Controller with the attached Handset on a clean, flat, stable surface.

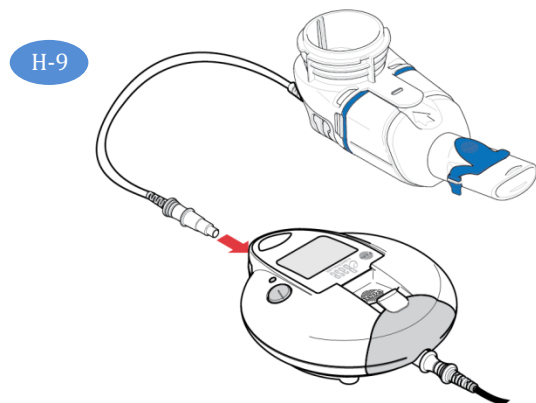

I Taking ARIKAYCE

Important information to know before you start

- If you use a **bronchodilator** (reliever), use the bronchodilator first, before using ARIKAYCE. Refer to your bronchodilator leaflet for information. The nebulizer for ARIKAYCE should only be used for giving ARIKAYCE.
- Each vial of ARIKAYCE is for **single (1 time) use only**.
- **Do not use** ARIKAYCE with any other type of Handset or Aerosol Head than the one provided in the carton.
- **Do not put** other medicines in the Lamira Nebulizer Handset.
- **Do not drink** the liquid in the vial.
- **Do not use** ARIKAYCE if the expiration date has passed.

Getting your ARIKAYCE ready before adding it to the Lamira Nebulizer Handset.

Step I1: Shake the ARIKAYCE vial well for at least 10 to 15 seconds, until the medicine looks the same throughout and well mixed (I-1).

Step I2: Lift orange cap from vial and throw away (dispose of) the orange cap (I-2).

Step I3: Grip metal ring on top of the vial. Pull it down gently (I-3) until 1 side breaks away from the vial (I-3a).

Step I4: Pull the metal band from around the vial top in a circular motion until it comes off completely from the vial (I-4). Throw away (dispose of) the metal band after it is removed.

Step I5: Carefully remove the rubber stopper by pulling it upward (I-5).

Step I6: Make sure your Handset is placed on a clean, flat, stable surface. Pour 1 vial of ARIKAYCE into the Medication Reservoir (I-6). Do not use more than 1 vial for each treatment.

Your ARIKAYCE should be at room temperature before use to make sure that your Lamira operates properly. Bring ARIKAYCE to room temperature by removing it from the refrigerator at least 45 minutes before use. Do not use if your ARIKAYCE has been frozen.

Do not use other medicine in your handset.

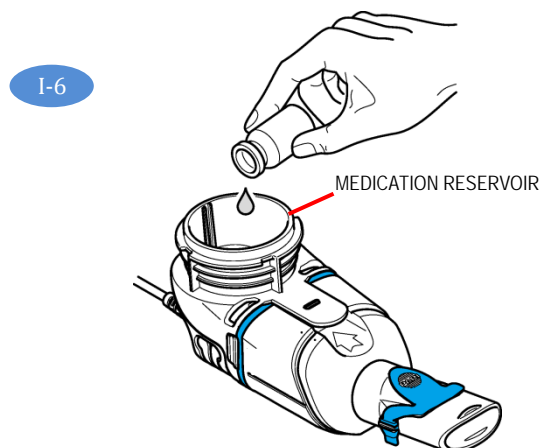
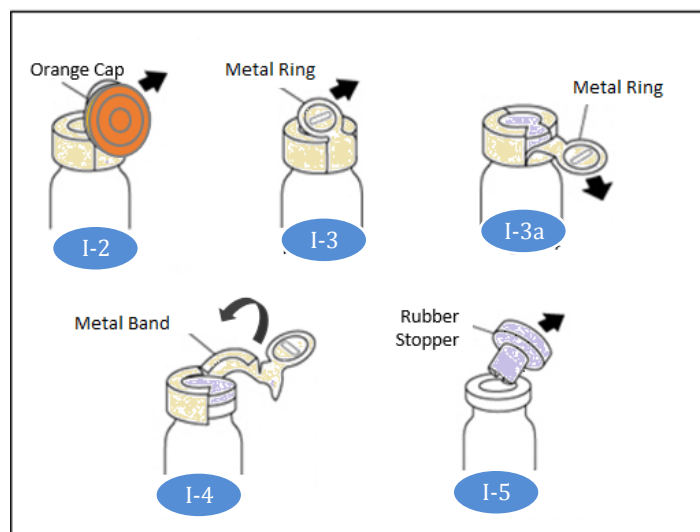

I Taking ARIKAYCE (continued)

Step 17: Attach the Medication Cap by lining up the Tabs on the Medication Cap with the Tab Slots on the Medication Reservoir (I-7). Turn the Medication Cap clockwise until it stops. As the Medication Cap is turned, the inner cap of the Medication Cap should rise.

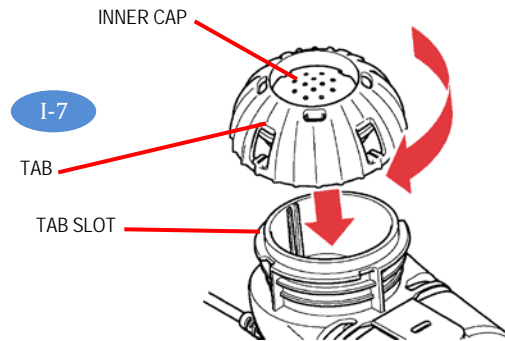

Step 18: To begin your treatment, sit in a relaxed, upright position. Press and hold the On/Off (2 to 3 seconds) (I-8) until the start screen appears on the LCD display (I-8a). You will also hear 1 “beep” and the status light will turn green. The Lamira is now On.

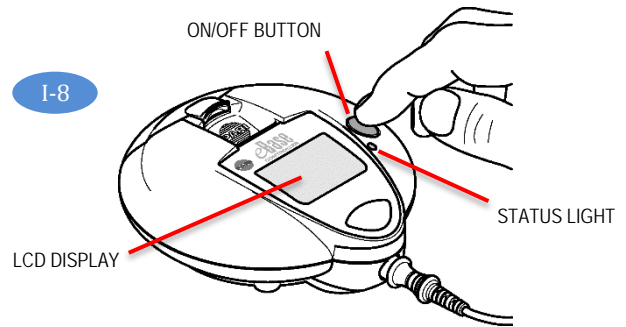

After treatment begins, the treatment screen (I-8b) will replace the start screen (I-8a) and aerosol mist will begin to flow.

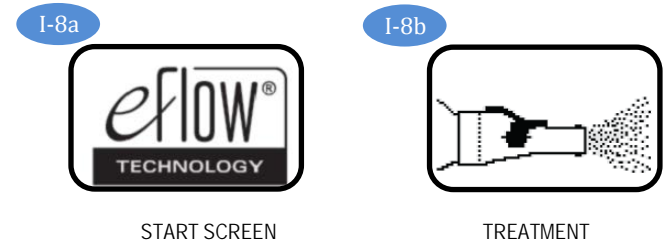

Step 19: Insert the Mouthpiece by placing it on top of your bottom lip and tongue. Close your lips around the Mouthpiece (I-9). Take slow, deep breaths then breathe normally in and out through the Mouthpiece until your treatment is complete. Your treatment should take about 14 minutes, but could take up to 20 minutes.

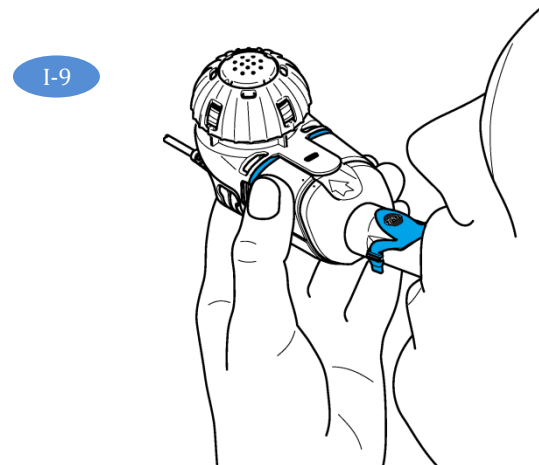

I Taking ARIKAYCE (continued)

Hold the Handset level throughout your treatment. If the Handset is held at an angle over 45 degrees (I-9a), it will sound 2 beeps (and 2 green lights) and shut off after 30 seconds. If this occurs, hold the Handset level and press the On/Off Button to start your treatment again.

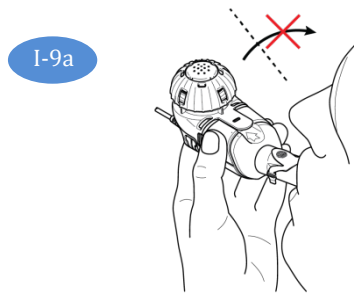

Note: The Lamira can be stopped at any time during operation by pressing the On/Off button for 3 seconds. The screen will go from On (I-9b) to Pause (I-9c), a 5-beep alarm tone will sound, and the status light on the Controller will flash Red-Green. To resume your treatment, press the Controller On/Off button for 1 full second. The Controller will run for up to 20 minutes. If your treatment is not complete after 20 minutes, press the On/Off button to continue treatment.

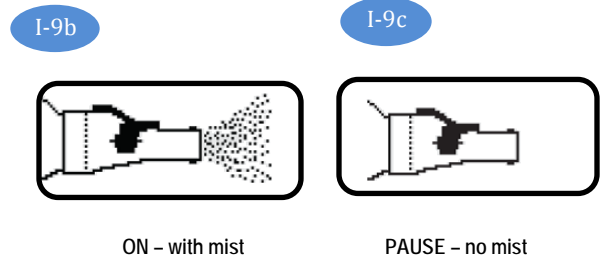

Important Information:

The amount of time to nebulize your ARIKAYCE may change from dose to dose and may become longer unless the cleaning and maintenance instructions are followed (See Maintaining Your Lamira).

Step I10: At the end of your treatment, the following will happen:

- The Lamira will beep 2 times.
- The LED will flash red 2 times.
- The Dose Complete Checkmark will appear briefly on the screen (I-10a).
- The Controller will automatically shut off.

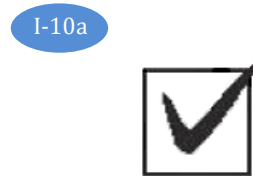

Always check the Medication Reservoir by removing the Medication Cap (I-10b) to make sure you have completed your dose. If more than a few drops of ARIKAYCE remains, replace the Medication Cap (I-10c) and press On/Off start button and complete your dose.

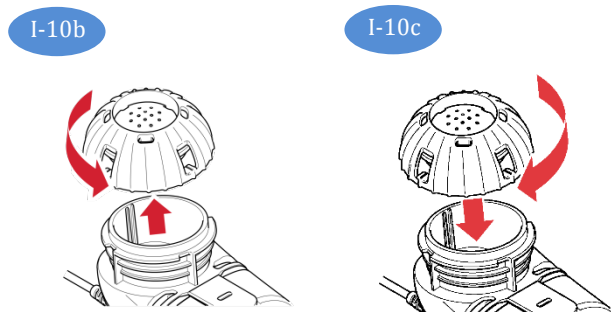

Change your Aerosol Head after 7 uses. After the Aerosol Head has been used 7 times, replace it with a new Aerosol Head during the cleaning process. Follow the instructions in Steps F6 through F9 and replace the Aerosol Head with a new one.

Important: Clean and disinfect your Handset after each use. See sections F and G for instructions.

Change your Aerosol Head after 7 uses.

QUESTION 1: How long should my ARIKAYCE treatment take?

Answer: With normal operation and proper cleaning, your Handset should deliver 1 vial of ARIKAYCE in about 14 minutes but could take up to 20 minutes. Your Lamira should automatically shut off shortly after your treatment is complete or after 20 minutes. If the Lamira turns off after 20 minutes, check the Medication Reservoir. If it is empty, you have received your full dose.

QUESTION 2: How much ARIKAYCE should be left in the Medication Reservoir at the end of my treatment?

Answer: Only a drop of ARIKAYCE should remain in the Medication Reservoir. If more than a drop remains, start the Controller and complete your dose. Then clean the Aerosol Head (Section F). If after proper cleaning, more than a drop remains in the Medication Reservoir, contact the Arikares Support Program at 1-833-ARIKARE (1-833-274-5273).

QUESTION 3: When I turn on my Nebulizer, nothing happens. There does not seem to be any power.

Answer: If you are using batteries, use the figures in each Battery Compartment to check that the batteries are inserted correctly. If the batteries are positioned properly, check to see if the light is blinking on the Controller signaling low battery power. If it is, replace the batteries or use the A/C Power Supply.

Answer: If you are using the A/C Power Supply, check the connection to be sure it is firmly connected to the Power Supply Port located underneath the Battery Compartment.

Be sure that the A/C Power Supply is plugged into a working wall outlet.

QUESTION 4: Sometimes I have trouble removing the Medication Cap at the end of my therapy session.

Answer: A vacuum has formed in the Medication Reservoir. Remove the Connection Cord, open the Handset and carefully remove the Aerosol Head. The Medication Cap will then be easier to remove.

QUESTION 5: What if no mist is coming out of your Handset?

Answer: First, check that the Controller has power. Secondly, make sure the Connection Cord is correctly attached. Thirdly, check to be sure that your Handset has been assembled properly (Section H). Lastly, check to be sure that the ARIKAYCE is in the Medication Reservoir. If the Controller or your Handset still do not function properly, contact the Arikares Support Program at 1-833-ARIKARE (1-833-274-5273).

QUESTION 6: What if liquid is leaking from my Handset during my treatment?

Answer: To prevent leaks, be sure (1) the Blue Valve is properly attached to the Aerosol Chamber, (2) the Aerosol Head is inserted correctly, (3) the Medication Cap is screwed on fully, and (4) the Medication Reservoir and Aerosol Chamber are closed properly and *snapped* together.

Answer: It is normal to have some liquid collect in the Aerosol Chamber. Try to hold the Handset so that liquid does not pour out of the Mouthpiece.

QUESTION 7: What if my Controller shuts off before my treatment begins, or does not restart?

Answer: Low voltage. Replace the batteries or use the AC adapter. Press the On/Off button to continue your treatment.

Answer: Your Handset was tilted above 45°. Hold your Handset level and press the On/Off button to continue your treatment.

Answer: ARIKAYCE is cold. Allow the ARIKAYCE to warm to room temperature and then press the On/Off button to continue your treatment.

QUESTION 8: What if my Controller does not shut off at the end of my treatment?

Answer: Your Controller may take up to 60 seconds to shut off after you complete your dose. If you wish to stop your Controller earlier, press the On/Off button.

Answer: Disconnect the A/C Power Supply from the Controller and remove the batteries. Then, reinsert the Batteries following the procedure in Section D.

Answer: If this situation continues 3 or 4 times, contact the Arikares Support Program at 1-833-ARIKARE (1-833-274-5273).











QUESTION 9: How long will a new set of batteries last?

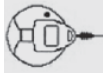

Answer: A new set of batteries should provide 2 hours of total use.

Answer: Consider using rechargeable batteries.

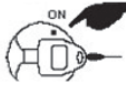
QUESTION 10: What if something arrives damaged?

Answer: Contact the Arikares Support Program at 1-833-ARIKARE (1-833-274-5273).

| | Fault and Condition | Possible Cause and Solution |
|----|--|---|
| 1 | Steady  | Controller running on AC Power. |
| 2 | Steady  | Controller running on battery power. |
| 3 | Flashing  | Empty battery, replace batteries or switch to A/C power. |
| 4 | Flashing  The LED changed from green to red and the battery symbol is blinking during treatment | Low battery, replace batteries or switch to A/C power. |
| 5 | Flashing  Lamira turns on but LED flashes green-red and LCD display flashes this symbol | Bad or missing Connection Cord. Check Connection Cord between Handset and Controller. Bad or missing Aerosol Head. Correct then restart Controller. |
| 6 | Flashing  Lamira beeps 1x, then beeps high-low with the LED flashing and the LCD display flashing this symbol | No ARIKAYCE detected. Add ARIKAYCE. If you have already added ARIKAYCE, gently tap the Handset, hold the Handset level and restart the Controller. |
| 7 | Flashing  Lamira beeps low-high 3 times, the LED flashed green-red, the LCD displays this symbol, and then turns off | Have reached 20 minute maximum time and will shut down. If ARIKAYCE remains, restart the Controller. After treatment is complete, clean and disinfect the Handset including the Aerosol Head. |
| 8 | Steady  Lamira beeps 1 time and LCD shows this symbol | Misting and working properly. |
| 9 | Steady  | Controller has paused. To resume press On/Off button. |
| 10 | Flashing  | Press button to start treatment. |
| 11 | Brief  | Functioning properly, the Controller has started properly. |

| | Fault and Condition | Possible Cause and Solution |
|----|---|--|
| 12 | Brief  <p>The Lamira beeps 2 times, displays this checkmark symbol then turns off.</p> | No ARIKAYCE remaining, your treatment is done. If ARIKAYCE is remaining, your Handset might be tilted. Keep Handset level, gently tap Handset and restart Controller. |
| 13 | <p>The Lamira cannot be activated and no green LED, no screen, and no beep.</p> | Bad, missing or misloaded batteries. Bad or missing A/C Power Supply. |
| 14 | <p>The Lamira beeps 1 time and begins to produce a mist, then stops and shuts off with no beep, no LED, and with ARIKAYCE still present.</p> | Bad batteries or bad A/C Power Supply. Replace batteries or A/C Power Supply and restart Controller. |
| 15 | <p>The Lamira stops before ARIKAYCE is completely used up.</p> | Lost power. Replace batteries or use A/C Power Supply. Tilted Handset. Keep Handset level, gently tap Handset and restart Controller. |
| 16 | <p>The Lamira does not stop automatically after all ARIKAYCE is consumed</p> | Clean and disinfect the Aerosol Head. If condition continues, contact the Arikares Support Program at 1-833-ARIKARE (1-833-274-5273). |
| 17 | <p>Longer than normal nebulization time.</p> | Aerosol Head is dirty. Clean and disinfect the Aerosol Head. Replace the Aerosol Head with a new one from your kit after 7 uses. |
| 18 | <p>Handset leaks.</p> | Make sure Blue Valve is placed correctly in the Handset and the 2 flaps point into the Handset Chamber (see Section H). Make sure Aerosol Head is correctly placed in the Handset. It is normal to have some liquid collect in the Aerosol Chamber and Mouthpiece. The amount depends on the volume of the ARIKAYCE and on your breathing pattern. |
| 19 |  | The On button was accidentally pressed for 10 seconds, which activated the easycare function. The easycare is an accessory that assists in cleaning the Aerosol Head but it is not used for your Lamira. Press the On button briefly to turn-off the Controller and stop the easycare function. |



Specifications

Mechanical

| | |
|---|--------------------|
| Weight: Controller and Handset..... | approx. 8.2 oz. |
| Weight: Controller, Handset, and Batteries..... | approx. 11 oz. |
| Handset Dimensions (W x H x D) | 2.0" X 2.4" X 5.5" |
| Controller Dimensions (H x Ø) | 1.6" X 4.6" |
| Minimum Fill Volume | 0.5 mL |
| Maximum Fill Volume | 8.4 mL |

Electrical

| | |
|-------------------------------|-----------------------------|
| Electrical Requirements | 110 V - 240 V, 50 Hz/60 Hz |
| Power Wattage | 2.0 Watts under normal load |

Transport and Storage

| | |
|---|----------------|
| Temperature | -13° to 158° F |
| Relative Humidity (non-condensing)..... | 0% to 93% |
| Air Pressure..... | 9 to 15 PSI |

Operational

| | |
|---|---------------|
| Temperature | 41° to 104° F |
| Relative Humidity (non-condensing)..... | 15% to 93% |
| Air Pressure..... | 10 to 15 PSI |

Device Classification According to IEC 60601-1

| | |
|---|---------------------|
| Type of electric shock protection (AC power adapter)..... | Protection Class II |
| Degree of protection from electric shock of part used (nebulizer) | Type BF |
| Degree of protection against water ingress per IEC 60529 IP rating (nebulizer)..... | IP 21 |
| Degree of protection when in the presence of flammable mixtures | No protection |
| Continuous operation..... | Operating mode |

Device Performance Characteristics

| | Mean | Range ^a |
|--|-------|--------------------|
| Total Delivered Dose by Breath Simulation ^b (mg) | 312.1 | 273.8 – 350.4 |
| Total Delivered Dose by Breath Simulation (% of label claim ^c) | 52.9 | 46.4 – 59.4 |
| MMAD ^d by NGI ^e (µm) | 4.45 | 4.38 – 4.52 |
| GSD ^f | 1.59 | 1.59 – 1.60 |
| Respiratory Dose by NGI (≤ 5µm, mg) | 327.1 | 316.5 – 337.6 |
| Respiratory Fraction by NGI (≤5µm, % of delivered dose) | 55.6 | 53.8 – 57.4 |

^a Range - two-sided tolerance interval, proportion of total population=0.95
^b Breath simulation - tidal volume of 500 mL, 15 breath per minutes, and inhalation:exhalation ratio is 50:50
^c label claim - 590 mg
^d MMAD - Mass Median Aerodynamic Diameter
^e NGI - Next Generation Impactor
^f GSD - Geometric Standard Deviation

Handset materials

Polypropylene, polyamide, silicone, stainless steel, thermoplastic elastomers. Does not contain any natural rubber (latex).

Disposal

The Lamira components and batteries must be disposed of in accordance with local (state, county or municipal) regulations.

Manufactured by:

PARI Respiratory Equipment, Inc.
 2412 PARI Way
 Midlothian, Virginia 23112 USA
 For patent information: www.PARI.com/ip

©2018 PARI Pharma GmbH. All rights reserved. The PARI logo is a registered trademark of PARI GmbH. Altera®, eRapid®, and eFlow® logo are registered trademarks of PARI Pharma GmbH. Lamira™ is a trademark of PARI Pharma GmbH. ARIKAYCE is a registered trademark of Insmid Incorporated.. Touchspray® made under license from the Technology Partnership.

This Instructions for Use has been approved by the U.S. Food and Drug Administration

678D0204 Draft Rev 18a 9/18