

**BJA<sup>®</sup>**

# TBF TAPE BINDER

## INSTRUCTION MANUAL

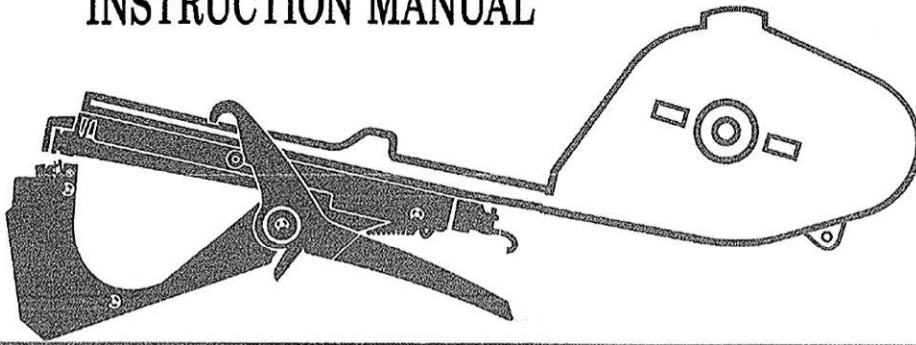

### SPECIFICATIONS

Name	BJA TAPE BINDER Model TBF
Dimensions	158mmH x 29mmW x 355mmL
Staples Used	604E-L
Tape Used	BJA Tape B02 GREEN 11mm x 28m 150 micron thickness
Weight	530gram
Bundling Limit	Max 45mm $\phi$
Blade	BJA Serrated Blade(TBF006)

### HOW TO USE

#### How to Load Staple

- 1 Hold the body with left hand, push up the knob (A) of the pusher unit with right hand, and pull it out backwards.

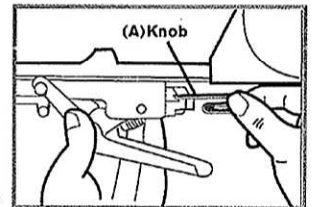

(Fig. 1)

- 2 Pick up staples (B) with right hand and load them into the magazine unit with the staple legs pointing downward; then set them in the pusher unit.

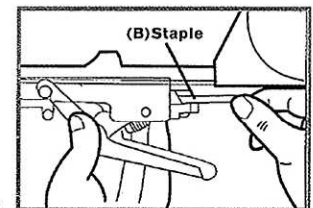

(Fig. 2)

#### How to Open Tape Holder

- 1 Put your finger on UP part(D), then open the cover with the thumb pressing the UP part.

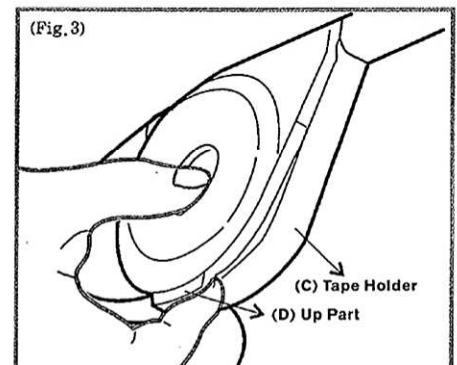

(Fig. 3)

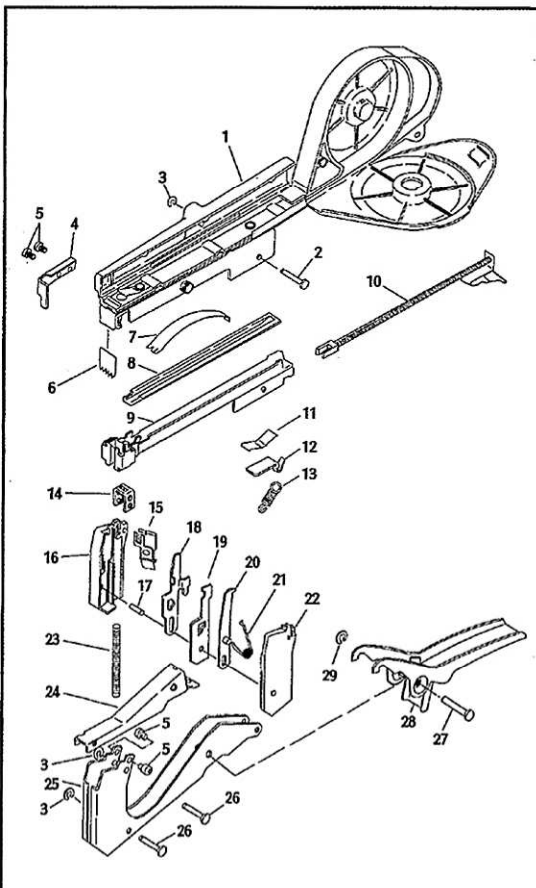

Index No.	Parts Code No.	Description
1	TBF001	Tape Guide
○ * 2	TBF002	Step Pin - A
○ * 3	TBF003	E-Type Retaining Ring -A
○ * 4	TBF004	Rod Holder
○ * 5	TBF005	" + " Screw
○ * 6	TBF006	Serrated Blade
○ * 7	TBF007	Leaf Spring - A
○ * 8	TBF008	Staple Cover
○ 9	TBF009	Magazine Unit
○ * 10	TBF010	Pusher Unit
○ * 11	TBF011	Leaf Spring - B
○ * 12	TBF012	Spring Hook
* 13	TBF013	Tension Spring
○ * 14	TBF014	Clincher
○ 15	TBF015	Support Plate
16	TBF016	Head Case - A
○ * 17	TBF017	Straight Pin
○ * 18	TBF018	Push Plate
○ * 19	TBF019	Clutch Plate
○ * 20	TBF020	Tape Catch Plate
* 21	TBF021	Torsion Coil Spring
22	TBF022	Head Case - B
* 23	TBF023	Compression Spring
○ * 24	TBF024	Inner Cover
* 25	TBF025	Outer Cover
○ * 26	TBF026	Step Pin - B
○ * 27	TBF027	Step Pin - C
* 28	TBF028	Handle Unit
○ * 29	TBF029	E-Type Retaining Ring - B

\*-parts interchangeable with Model TB-B.  
○-parts interchangeable with Model TB-S.

## How to Load the tape

- 1 Open the tape holder (C) cover as mentioned above, and load the tape as shown, and then close until it "snaps".

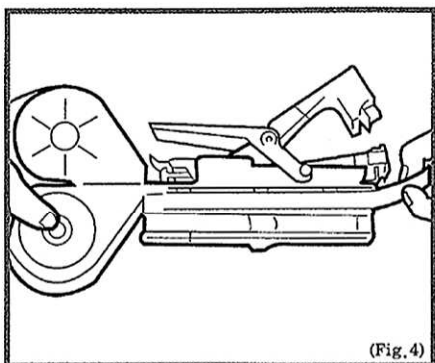

(Fig. 4)

- 2 Set the tape. Hold lightly the head of the Tape Guide with left thumb, and pull the tape downward with right finger. The tape will be set in the tape guide.

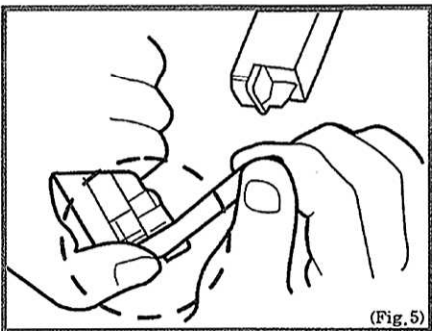

(Fig. 5)

## How to Pull Out Tape

- 1 Grip the handle so that the tape catch will catch the tape end.  
Note : After the tape catch has caught the tape end, do not press the handle harder the tape catch will go back to its normal position, resulting in no pressing of the tape.

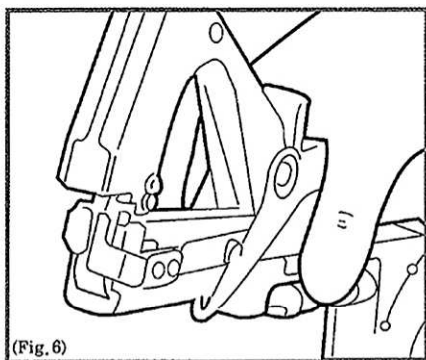

(Fig. 6)

- 2 Release the handle as explained above. The tape will then be pulled out.

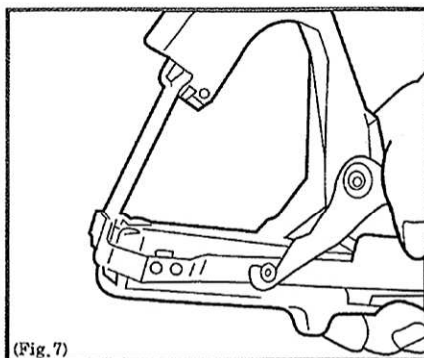

(Fig. 7)

- 3 It might happen that the tape catch will not catch the tape end when you press the handle. (This not trouble with the machine.) If this happens, press the tape catch will return to its normal position.

Note : This should be done only when the tape catch does not catch the tape end.

## How to Bundle Objects

- 1 Press the tape against the object until it is positioned inside the Tape Binder.

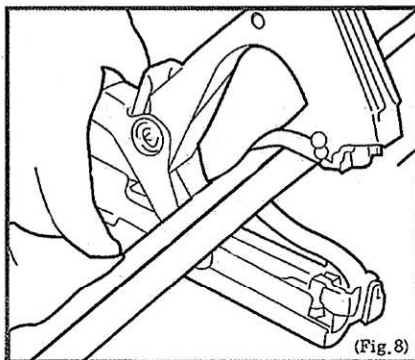

(Fig. 8)

- 2 Then, press the handle fully with the tape positioned centrally, and the object will be bundled by both the tape and staple : simultaneously, the tape is cut off.

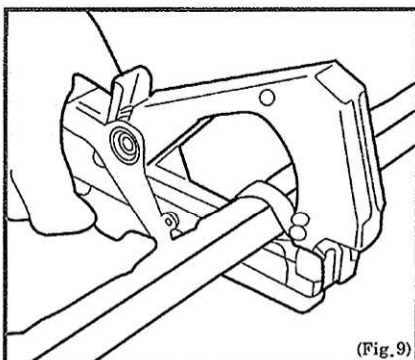

(Fig. 9)

## How to Correct Stuck Staples

- 1 Dismount Pusher Unit and remove the staples loaded, then remove the stuck staples with a steel wire or a small screw driver.

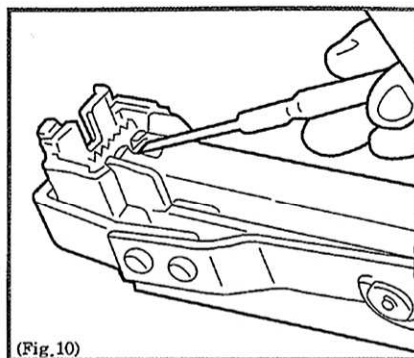

(Fig. 10)

## How to Change Blade

- 1 When the blade becomes worn and not sharp enough to efficiently cut the tape, it should be replaced with a new blade.

Caution : Use the BJA blade (TBF006), for proper tape cutting action and your safety.

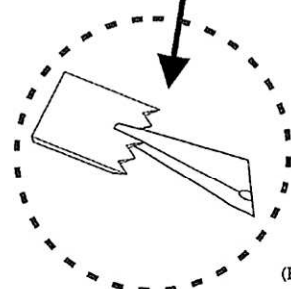
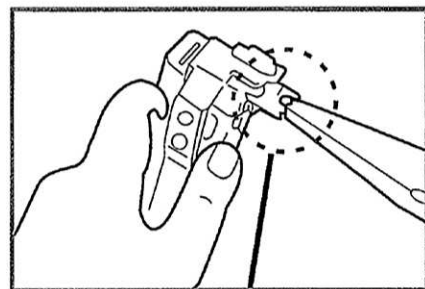

(Fig. 11)

**Note : Make sure the direction of blade like above figure.**

## How to maintain

- 1 After or before working, you are best to oil the three pivot points.

Spare Parts:

- One(1) blade (TBF006)
- Two(2) spring (TBF013)

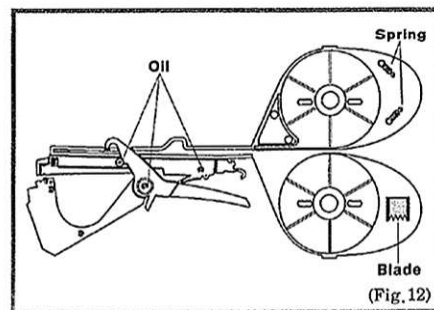

(Fig. 12)