



**NONRESIDENT  
TRAINING  
COURSE**



---

# **Gas Turbine Systems Technician (Electrical) 3/Gas Turbine Systems Technician (Mechanical) 3, Volume 1**

**NAVEDTRA 14113**

# **SUMMARY OF GAS TURBINE SYSTEMS TECHNICIAN (ELECTRICAL) 3/GAS TURBINE SYSTEMS TECHNICIAN (MECHANICAL) 3 TRAINING MANUALS**

## **VOLUME 1**

*Gas Turbine Systems Technician (Electrical) 3/Gas Turbine Systems Technician (Mechanical) 3, Volume 1*, NAVEDTRA 14113, covers information on the ratings, administration and programs, tools and test equipment, electrical theory and mechanical theory, piping systems and their components, support and auxiliary equipment, the power train, the controllable pitch system, and engineering electrical systems and their maintenance procedures.

## **VOLUME 2**

*Gas Turbine Systems Technician (Electrical) 3/Gas Turbine Systems Technician (Mechanical) 3, Volume 2*, NAVEDTRA 14114, contains information on the basic fundamentals of gas turbines, the LM2500 gas turbine, the Allison 501-K17 gas turbine generator, engineering systems, electric plant operation, and the control consoles for the CG-, DD-, DDG-, and FFG-class ships.

## PREFACE

By enrolling in this self-study course, you have demonstrated a desire to improve yourself and the Navy. Remember, however, this self-study course is only one part of the total Navy training program. Practical experience, schools, selected reading, and your desire to succeed are also necessary to successfully round out a fully meaningful training program.

**COURSE OVERVIEW:** This course is designed to assist enlisted personnel in the advancement to GSE Third Class Petty Officer/GSM Third Class Petty Officer. In completing this course you will demonstrate a knowledge of course materials by correctly answering questions on the following topics: the requirements for advancement to GSE3 and GSM3; programs and record keeping procedures needed for the safe operation of the main propulsion systems and the auxiliary equipment aboard ship; proper use of various tools, test equipment, and indicating instruments used aboard gas turbine ships; basic concepts of electrical theory, mechanical theory, and scientific principles applicable to gas turbine engines; the operation and components of auxiliary equipment, including valves and piping system components, main reduction gears and controllable pitch propeller systems, fuel and lube oil systems, associated pumps, and waste heat boiler systems; and basic troubleshooting methods, minor repairs, and test on motors, controllers, and switchboards.

**THE COURSE:** This self-study course is organized into subject matter areas, each containing learning objectives to help you determine what you should learn along with text and illustrations to help you understand the information. The subject matter reflects day-to-day requirements and experiences of personnel in the rating or skill area. It also reflects guidance provided by Enlisted Community Managers (ECMs) and other senior personnel, technical references, instructions, etc., and either the occupational or naval standards, which are listed in the *Manual of Navy Enlisted Manpower Personnel Classifications and Occupational Standards*, NAVPERS 18068.

**THE QUESTIONS:** The questions that appear in this course are designed to help you understand the material in the text.

**VALUE:** In completing this course, you will improve your military and professional knowledge. Importantly, it can also help you study for the Navy-wide advancement in rate examination. If you are studying and discover a reference in the text to another publication for further information, look it up.

*1989 Edition Prepared by  
GSCS Bradford E. Edwards and  
GSEC Edward E. Ragsdale*

Published by  
NAVAL EDUCATION AND TRAINING  
PROFESSIONAL DEVELOPMENT  
AND TECHNOLOGY CENTER

**NAVSUP Logistics Tracking Number  
0504-LP-026-7790**

# CONTENTS

| CHAPTER  | Page    |
|--|---------|
| 1. Rating Information .....  | 1-1     |
| 2. Administration and Programs .....                               | 2-1     |
| 3. Tools and Test Equipment. ....                                  | 3-1     |
| 4. Electrical Theory and Mechanical Theory.....                    | 4-1     |
| 5. Indicating Instruments.....                                     | 5-1     |
| 6. Piping System Components .....                                  | 6-1     |
| 7. Engineering Support and Auxiliary Equipment .....               | 7-1     |
| 8. Power Train and Controllable Pitch Propeller .....              | 8-1     |
| 9. Engineering Electrical Equipment .....                          | 9-1     |
| 10. Engineering Electrical Equipment Maintenance .....             | 10-1    |
| APPENDIX   |         |
| I. Glossary .....  | AI-1    |
| II. Abbreviations and Acronyms .....                               | AII-1   |
| III. Electrical Symbols .....                                      | AIII-1  |
| IV. Piping Print Symbols .....                                     | AIV-1   |
| V. Metric System. ....   | AV-1    |
| VI. List of Navy Electricity and Electronics Training Series ..... | AVI-1   |
| INDEX.....   | INDEX-1 |



# INTRODUCTION

The purpose of this manual is to provide you with the basic foundation of information you need as you continue to advance in the Navy. After reading this manual, you should be able to recognize the increased responsibility needed for advancement and to identify the other sources of information available to you. As you attain each promotional level in your chosen rating, you, as well as the Navy, will benefit. The Navy will benefit and you will continue to do so as you become more adept at the technical aspects of your rating. With each advancement, you accept an increasing responsibility in military and occupational matters.

You will find that your responsibilities for military leadership are the same as those of petty officers in other ratings. Every petty officer is a military person as well as a technical specialist. However, your responsibilities for technical leadership are special to your rating. They are directly related to the nature of your work. Operating and maintaining the ship's engineering systems and equipment is a job of vital importance, and it requires teamwork.

Before you study this book, we recommend that you complete or at least review the following Navy courses:

- Navy Electricity and Electronics Training Series (NEETS), Modules 1, 2, 3, 4, 5, 16, and 21.

The NEETS was developed for use by personnel in many electrical- and electronic-related Navy ratings. Written by, and with the advice of, senior technicians in these ratings, this series provides beginners with fundamental electrical and electronic concepts through the medium of self-study. The presentation is not oriented to any specific rating structure. This series is divided into 22 modules that contain related information organized in traditional paths of instruction. Module 1 introduces you to the course with a short history of electricity and

electronics and proceeds into the characteristics of matter, energy, and direct current. Module 1 also describes some of the general safety precautions and first-aid procedures that should be common knowledge for a person working in the field of electricity. Related safety hints are located throughout the rest of the series. Modules 2 through 5 deal with the generation of electricity; the application of resistors, capacitors, and inductors; and the phenomena of alternating current. Module 16 introduces the beginner to some of the more commonly used pieces of test equipment and their applications. Module 21 introduces you to alternative methods of performing electronics measurements.

As you progress up the ladder of advancement, and to further your knowledge of electricity and electronics, we recommend you become familiar with the remaining 15 modules of this series.

- *Basic Machines*, NAVPERS 10624

*Basic Machines* was written as a reference for the enlisted person in the Navy whose duties require knowledge of the fundamentals of machinery. It begins with the simplest of machines (the lever), then proceeds with a discussion of other types of machines—the block and tackle, wheel and axle, inclined plane, and screw and gear. It explains the concepts of work and power, and differentiates between the terms *force* and *pressure*. The fundamentals of hydrostatic and hydraulic mechanisms are discussed in detail. The final chapters of the book include several examples of the combinations of simple mechanisms to make complex machines.

- *Use and Care of Hand Tools and Measuring Tools*, NAVEDTRA 12085

This training manual (TRAMAN) was written to aid in the maintenance effort. It provides descriptions, general uses, correct operation, and approved maintenance procedures for those hand

tools and power tools commonly used in the Navy. It stresses the importance of good workmanship. Also, by emphasizing good safety practices, it aids in the prevention and minimizing of personnel and equipment damage.

To help you study any book, you should become acquainted with its design. Here are some things you should know about this TRAMAN and its associated nonresident training course (NRTC).

- This TRAMAN is designed to help you fulfill professional requirements for advancement to GSE3 and GSM3. The manual was prepared using the GSE3 and GSM3 occupational standards (OCCSTDs) prescribed by the Chief of Naval Personnel in the *Manual of Navy Enlisted Manpower and Personnel Classifications and Occupational Standards*, NAVPERS 18068 (VOLUME 1). This manual contains the information needed to establish a good foundation for both GSEs and GSMs.

- The Personnel Qualification Standards (PQS) and OCCSTDs for the GSE3 and GSM3 ratings are very similar; therefore, it was more economical to develop a single TRAMAN. We wish to emphasize that the two ratings are separate. In writing one TRAMAN, we absolutely do not intend to infer that the ratings should be compressed at the third class petty officer level.

- This GSE3/GSM3 TRAMAN is written to the OCCSTDs, personnel advancement requirements (PARS), and PQS of the various watch stations of both ratings. Chapter 10 of this TRAMAN is unique to the GSEs.

- You must satisfactorily complete this TRAMAN before you can advance to GSE3 or

GSM3. This is true whether you are in the regular Navy or in the Naval Reserves. However, those personnel who satisfactorily complete Gas Turbine A School may have this course waived by the local command.

- This TRAMAN is written to provide you a basic foundation of information that you will use throughout your naval career as a GSE or GSM. You will find additional information and terminology for your rating in the following appendixes:

Appendix I—a glossary of terms peculiar to the GS ratings. Use it whenever you are not sure of the meaning of a word.

Appendix II—a list of abbreviations and acronyms used throughout this TRAMAN.

Appendix III—electrical and electronic symbols.

Appendix IV—piping print symbols.

Appendix V—metric system.

Appendix VI—list of the NEETS modules.

Appendix VII—list of reference materials used to prepare this TRAMAN.

Information can be organized and presented in many different ways. Before you study the chapters in this book, read the table of contents and note the arrangement of information in this TRAMAN. You will find it helpful to get an overall view of the organization of this TRAMAN before you start to study it.

# CHAPTER 1

## RATING INFORMATION

This training manual is designed to help you increase your knowledge in the various aspects of the Gas Turbine Systems Technician ratings. It will help you prepare for advancement to third class petty officer. Your contribution to the Navy depends on your willingness and ability to accept increasing responsibilities as you advance in rate. When you assume the duties of a Gas Turbine Systems Technician (Electrical) (GSE) or a Gas Turbine Systems Technician (Mechanical) (GSM), you begin to accept certain responsibilities for the work of others. As you advance in your career, you accept additional responsibilities in military subjects as well as occupational and training requirements for the GSE or GSM rating.

After studying this chapter, you should be able to describe the GSE/GSM ratings in terms of their history and present status, to identify the duties and responsibilities of GSEs and GSMs, to summarize the advancement requirements for GSEs and GSMs, and to list the general training sources available for you.

### FORMATION OF THE GSE/GSM RATINGS

In late 1975, with the commissioning of the USS *Spruance* (DD-963), the Navy realized there was a need for the formation of a specialized gas turbine rating. At that time, personnel drawn primarily from the Electrician's Mate (EM), Engineman (EN), and Interior Communications Electrician (IC) ratings were being put through special gas turbine pipeline training for duty aboard the new gas turbine ships. Then, in 1978 the decision was made to form the GSE and GSM ratings. On October 1, 1978, both ratings were put into effect. All EMs, ENs, and ICs with DD-963 class Naval Enlisted Classification Codes (NECs) were converted to GSE or GSM, as applicable. Then, with the introduction of the *Oliver Hazard Perry* (FFG-7) to the fleet, more schools and NECs were required to train

personnel properly to maintain and to operate these ships.

### DUTIES AND RESPONSIBILITIES

A third class GSE or GSM has the opportunity to work with a wide variety of main propulsion, auxiliary, and electrical equipment. The GSE is primarily responsible for the electronic control circuitry interfaces, such as signal conditioners, control consoles, and designated electrical equipment associated with shipboard propulsion and electrical power generating plants. The GSM is primarily responsible for the operation and maintenance of the gas turbine engines (GTEs), gas turbine generators (GTGs), reduction gears, and associated equipment (such as pumps, valves, oil purifiers, heat exchangers, shafts, and shaft bearings). As you continue to advance in the Navy, as a GSE or GSM you will increasingly cross-train between GSE and GSM. This will prepare you for more demanding assignments.

We have arranged the GSE3/GSM3 Volumes 1 and 2 manuals to give you a systematic understanding of your job. The occupational standards (OCCSTDs) used in preparation of the training manuals are contained in the *Manual of Navy Enlisted Manpower and Personnel Classifications and Occupational Standards*, NAVPERS 18068. We recommend that you study the GSE and GSM sections of NAVPERS 18068E to gain an understanding of the skills required of a GSE/GSM. Then study the subject matter carefully. The knowledge you gain will enable you to become a more proficient technician, and you and the Navy will profit from your skills.

### ADVANCEMENT REQUIREMENTS

The office of the Chief of Naval Operations monitors current and future vacancies in the



Navy. These vacancies are changed to quotas for each rate in all Navy ratings. Quotas are used to determine the number of selectees for advancement in each advancement cycle.

Your ability to fill one of the quotas in your rating depends on how well you know and do your job and on your desire and readiness for advancement. The Navy provides you with challenging work and training that helps you learn more about your job. Your seniors are interested in seeing you advance. They provide feedback to you through personal contact and performance evaluations. The rest is up to you.

## **ELIGIBILITY REQUIREMENTS FOR ADVANCEMENT**

You must complete several steps to become eligible for advancement. These steps include completing the time requirements, Personnel Advancement Requirements (PARs), and military required courses and tests; receiving a recommendation by your commanding officer; meeting physical readiness/body fat standards; completing required professional performance courses; and passing the advancement-in-rate examination. For more specific information on your eligibility, contact your educational services officer (ESO).

## **PROFESSIONAL DEVELOPMENT**

Two of the most important aspects of your professional development are **SUSTAINED SUPERIOR PERFORMANCE** and **STUDYING FOR ADVANCEMENT**. How you do your job determines how you are evaluated. To achieve an evaluation of sustained superior performance, you must demonstrate a continual outstanding job performance in all areas of your rate. Your exam performance, rating knowledge, and work performance demonstrate the extent of your studying.

### **Sustained Superior Performance**

Your key to success in the Navy is a sustained superior performance. You can be a top performer among your peers by reaching for your full potential. Remember, the higher your advancement goal, the stiffer the competition. Your performance evaluations must show that you are among the best in the Navy, not just at your present command. The Navy wants and promotes people with a record of doing the job

well. That means doing the job well on shore or at sea. Your performance is reported in your performance evaluation. Let's look at evaluations to see their impact on advancement.

**PERFORMANCE EVALUATIONS.**—Your **ENLISTED PERFORMANCE EVALUATION REPORT** is the most significant management tool in your service record. It is one of the first documents used by your superiors to make advancement decisions about you because it is a continuous record of your performance. You can influence what goes into your evaluation by having sustained superior performance. In plain words, always do top-notch work.

**PERFORMANCE MARK AVERAGE FACTOR.**—The average of your performance evaluation marks are converted to a performance mark average (PMA). This is one of the more important factors used to compute your final multiple score (FMS). Three factors are used in the figuring of your FMS—experience, performance, and exam score. Your FMS is used to rank-order you against all other candidates who take the same exam as you. To give you some idea of the impact your performance has on your FMS (and your chances for advancement), look at the following figures: If you are a candidate for PO3 or PO2, 30 percent of your FMS is based on your performance; if you are a PO1 candidate, the percentage is 35 percent; for CPO, it is 40 percent.

### **Studying for Advancement**

Closely related to your ability to perform in a superior manner is the amount and quality of studying you do. An advancement handbook (*Advancement Handbook for Petty Officers, Gas Turbine Systems Technician (GS)*, NAVED-TRA 71065) is available to help you prepare and study for advancement. A handbook exists for every rating in the Navy. Each handbook is divided into three parts. The first part explains the Navy Advancement System; the second part contains the naval standards (NAVSTDs) with their supporting bibliography; the third part contains the OCCSTDs with their supporting bibliography and the PARs. Your rating handbook shows you what courses are mandatory requirements for advancement.

You should concentrate on three major areas of study, (1) information particular to your job

and command responsibilities, (2) NAVSTDs, and (3) OCCSTDs.

**NAVAL STANDARDS.**—The NAVSTDs describe knowledge and abilities required of every enlisted person in the Navy. The NAVSTDs are cumulative; that is, as you advance in paygrade, you are responsible for NAVSTDs in the paygrade you are trying for, your present paygrade, and all paygrades below. You are tested on your knowledge of NAVSTDs by the military/leadership exams for PO3 through CPO as part of your eligibility requirements.

**OCCUPATIONAL STANDARDS.**—The OCCSTDs are standards that express the Navy's minimum requirements for enlisted occupational skills established by manpower and personnel managers. The OCCSTDs are written as task statements. They form the foundation of a well planned system that dovetails your training, advancement, and job assignments. Besides prescribing tasks expected of you, OCCSTDs also indicate general paygrade responsibility levels. For example, OCCSTD 37012, Maintain Tools, is a routine task that is located at a lower paygrade; more difficult tasks, such as OCCSTD 37049, Supervise Engine Changeouts, are located at a higher paygrade. The OCCSTDs, like the NAVSTDs, are cumulative. That means as you advance in your rating, you are responsible for the OCCSTDs of the rate you are trying for, your present rate, and all lower rates.

**BIBLIOGRAPHIES FOR NAVSTDs AND OCCSTDs.**—You can find supporting bibliographies for NAVSTDs and OCCSTDs in either of two publications, the *Advancement Handbook for Petty Officers* and the *Bibliography for Advancement Study*, NAVED-TRA 10052 (current edition). The bibliographies in both of these publications contain the same references.

## **EXAM AND NOTIFICATION OF RESULTS**

The exam is a 150-question test that you will have up to 3 hours to take. After completing the exam, you will be given the SUBJECT-MATTER SECTION IDENTIFICATION SHEET (fig. 1-1). This is sometimes called the “tear-off sheet.” Keep this sheet. When you receive your EXAMINATION PROFILE INFORMATION FORM (fig. 1-2), you can look at the section of

the text that you need to work on because of low scores. The Subject-Matter Section Identification sheet has three columns. The first column shows the number of sections in the exam, the second column gives you the title of the sections, and the third column shows the OCCSTDs that were covered in that section. The Examination Profile Information form that you will receive when the exam results arrive at your command shows the examination section and your standing in that section compared to all others who took the same exam. The section number corresponds with the Examination Section column on the Subject-Matter Section Identification sheet. Use this information to discover the knowledge, strengths, and weaknesses that you were tested on in this exam only. By looking at the *Advancement Handbook for Petty Officer*, you will find the references used in making up that section of the exam.

## **TRAINING SOURCES**

The Navy provides various types of training. In this section we are going to discuss some of the different types of training and the different sources you can use in locating available training.

### **SCHOOLS**

The Navy provides three major types of schools to assist its personnel. The different types of schools are (1) the technical training schools, (2) Naval Leadership Development Program (NLDP) school, and (3) fire-fighting and damage control schools.

#### **Technical Schools**

The main school for gas turbine personnel is in Great Lakes, Illinois. The GSE/GSM “A” schools and the GSE/GSM “C” schools are located there; however, the Navy has other technical schools on both coasts that will assist personnel in their job. For more information about these other schools, you should talk to your divisional training petty officer.

#### **Naval Leadership Development Program School**

As you advance to third class petty officer, your responsibilities for military leadership will be about the same as those of petty officers in

GIVE THIS SHEET TO YOUR PROCTOR

SUBJECT-MATTER SECTION IDENTIFICATION FOR ALL

GSE 3

EXAMINATIONS WITH SERIAL NUMBERS FROM

1110001 TO 1119999

1. This examination is divided into SUBJECT-MATTER SECTIONS. The titles of these sections are general in nature and represent the occupational requirements at this rate. The chart below shows both the sectional breakdown for this rate and the standards from Section I of the Manual of Navy Enlisted Manpower and Personnel Classifications and Occupational Standards (NAVPERS 18068-D including Change 1) which support the questions.
2. The total bibliography for THIS examination is contained in Bibliography for Advancement Examination Study (NAVEDTRA 10052-AG) which is prepared in its entirety for your rating along with its appropriate Occupational Standards in a separate booklet. This booklet may be obtained from your ESO.
3. This SUBJECT-MATTER IDENTIFICATION SHEET is to be retained by your command until receipt of your examination results and your EXAMINATION PROFILE INFORMATION FORM. Fill in your NAME, RATE, DIV, and SHIP/STA in the spaces provided below before handing this sheet to your exam proctor.
4. Your EXAMINATION PROFILE INFORMATION FORM (explained on the back of this sheet) will be sent to you by separate correspondence. Using the SUBJECT-MATTER IDENTIFICATION SHEET and your EXAMINATION PROFILE INFORMATION FORM will assist you in identifying your strengths and weaknesses in comparison to other candidates for this examination.

| EXAMINATION SECTION | SUBJECT-MATTER TITLE                  | STANDARDS SUPPORTING THE QUESTIONS (FROM NAVPERS 18068)                     | NAME _____<br>DIV _____<br>SHIP/STA _____<br>RATE _____ |
|---------------------|---------------------------------------|---|---|
| 1                   | FUNDAMENTALS OF ELECTRICITY           | 14065, 14213, 14257, 24423, 24490, 26007, 46003                             |   |
| 2                   | TOOLS AND REPAIR EQUIPMENT            | 24007, 94163, 94799   |   |
| 3                   | COMPUTER PRINCIPLES AND LOGIC         | 14065, 24423, 26007, 31204  |   |
| 4                   | ELECTRICAL POWER DISTRIBUTION SYSTEMS | 14065, 14213, 24007, 24423, 28091, 88006, 88007                             |   |
| 5                   | TEST EQUIPMENT                        | 14257, 24423, 24490   |   |
| 6                   | GAS TURBINE PRINCIPLES                | 14065, 31003, 31204, 89005  |   |
| 7                   | ENGINEERING PLANT OPERATIONS          | 14257, 24032, 26007, 31003, 31198, 31204, 31205, 31206, 88005, 88007, 98240 |   |
| 8                   | 3-M SYSTEMS                           | 26007, 50929  |   |

THIS SHEET MUST BE USED WITH THE MANUAL OF NAVY ENLISTED MANPOWER AND PERSONNEL CLASSIFICATIONS AND OCCUPATIONAL STANDARDS (NAVPERS 18068)

Figure 1-1.—Subject-Matter Section Identification sheet.

NETISA 10461/94 (8-75)

**DEPARTMENT OF THE NAVY**  
 NAVAL EDUCATION AND TRAINING PROGRAM  
 DEVELOPMENT CENTER  
 PENSACOLA, FLORIDA 32509

  
 SERIES/DATE      ACTIVITY      CODE  
    12345      AB

FROM: COMMANDING OFFICER

TO: (YOUR NAME WILL APPEAR HERE)

SUBJ: EXAMINATION PROFILE INFORMATION

(YOUR EXAM SERIAL NUMBER AND THE DATE WILL APPEAR HERE)

---

THE INFORMATION PROVIDED BELOW IS A PROFILE OF YOUR RELATIVE STANDING WITH ALL OTHERS IN YOUR RATE IN EACH SUBJECT MATTER SECTION. THE INFORMATION IS TO BE USED WITH THE SUBJECT MATTER IDENTIFICATION SHEET FOR THE EXAMINATION SERIES INDICATED. STANDINGS ARE BASED ON OVER 90% RETURNS. NO SIGNIFICANT CHANGE WITH ALL RETURNS IN

| EXAMINATION STATUS | YOUR FINAL MULTIPLE | MINIMUM MULTIPLE REQUIRED | SECTION  | 1 | 2 | 3  | 4 | 5 | 6  | 7 | 8 | 9 | 10 | 11 | 12 | PAGE |
|--------------------|---------------------|---------------------------|----------|---|---|----|---|---|----|---|---|---|----|----|----|------|
|                    |                     |                           | STANDING | A | A | HA | L | P | LA | P | A | E |    |    |    |      |

COPY TO SERVICE RECORD      CODE INTERPRETATION     
 S: Superior+upper 10%      HA: High Average+upper 40%      L: Low+lower 30%  
 E: Excellent+upper 20%      A: Average+middle      P: Poor+lower 20%  
 H: High 30%      LA: Low Average+lower 40%      V: Very Poor+lower 10%

YOU MAY CONTACT YOUR ESO FOR DATA USED FOR YOUR MULTIPLE COMPUTATION

Figure 1-2.—Examination Profile Information form.

other ratings. (All petty officers have military as well as technical duties.) Operating and maintaining a ship's engineering plant and associated equipment requires teamwork along with a special kind of leadership ability that can only be developed by personnel who have a high degree of technical competence and a deep sense of personal responsibility. Strive to improve your leadership ability and technical knowledge through study, observation, and practical application.

Technical leadership involves more than just giving orders. In fact, you can demonstrate some of the most important aspects of technical leadership even if you are not directly supervising other personnel. As a GSE or GSM, you demonstrate technical leadership when you follow orders exactly, when you follow safety precautions, and when you accept responsibility. Also, when you continue to increase your professional knowledge and when you perform every detail of your work with integrity and reliability, you improve your technical leadership know-how.

Another way in which to gain additional leadership skills is through attendance at the Naval Leadership Development Program (NLDP) school. All petty officers should attend this school to fine tune the leadership skills they have attained through study, observation, and application.

### Fire-Fighting and Damage Control Schools

At various times throughout your Navy career, you may also attend various fire-fighting and damage control schools. There can NEVER be enough emphasis placed on the importance of damage control aboard ship. You will find that damage control and fire drills will be held routinely in port, at sea, and during special fleet exercises or refresher training. You must learn your duties for damage control emergencies to the very best of your ability because your life and the lives of your shipmates may depend on your actions.

### TRAINING MANUALS

There are two general types of training manuals (TRAMANS). RATING manuals (such as this one) are prepared for most enlisted ratings. A rating manual gives information directly related to the OCCSTDs of one rating. SUBJECT MATTER manuals or BASIC manuals give information that applies to more than one rating.

Training manuals are revised to keep them up-to-date technically. The revision of a rate training manual is identified by a letter following the NAVEDTRA number. You can tell whether any particular copy of a training manual is the latest edition by checking the NAVEDTRA number and the letter following this number in the most recent edition of the *List of Training Manuals and*

*Correspondence Courses*, NAVEDTRA 10061. (NAVEDTRA 10061 is actually a catalog that lists all current training manuals and courses; you will find this catalog useful in planning your study program.)

Each time a TRAMAN is revised, it is brought into conformance with the official publications and directives on which it is based. However, during the life of any edition of a TRAMAN, changes are made to the official sources and discrepancies arise. In the performance of your duties, you should always refer to the appropriate official publication or directive. If the official source is listed in *Bibliography for Advancement Study*, NAVEDTRA 10052, the Naval Education and Training Program Management Support Activity (NETPMSA) uses it as a source in preparing the fleetwide examinations for advancement. In case of a discrepancy between any publications listed in NAVEDTRA 10052 for a given rate, the examination writers use the most recent material.

Training manuals are designed to help you prepare for advancement. The following suggestions may help you make the best use of this manual and other Navy training publications when you prepare for advancement.

1. Study the NAVSTDs and the OCCSTDs for your rating before you study the training manual and refer to the standards frequently as you study. Remember, you are studying the manual primarily to meet these standards.

2. Set up a regular study plan. It will probably be easier for you to stick to a schedule if you can plan to study at the same time each day. If possible, schedule your studying for a time of day when you do not have many interruptions or distractions.

3. Before you begin to study any part of the manual intensively, become familiar with the entire book. Read the preface and the table of contents. Check through the index. Thumb through the book without any particular plan. Look at the illustrations and read bits here and there as you see things that interest you. Review the glossary. It provides definitions that apply to words or terms as they are used within the engineering field and within the text. There are many words with more than one meaning. Do not

assume that you know the meaning of a word! As you study, if you cannot recall the use of a word, look it up in the glossary. For your convenience, a list of abbreviations and a table on conversion to the metric system appear as appendixes in the back of this manual.

4. Look at the training manual in more detail to see how it is arranged. Look at the table of contents again. Then, chapter by chapter, read the introduction, the headings, and the sub-headings. In this manner you will get a pretty clear picture of the scope and content of the book. As you look through the book, ask yourself some questions.

- What do I need to learn about this?
- What do I already know about this?
- How is this information related to information given in other chapters?
- How is this information related to the OCCSTDs?

## EDUCATIONAL GUIDANCE

Numerous personnel are available aboard ship who can assist you in furthering your Navy education.

### Divisional Training Petty Officer

Your divisional training petty officer can help you with any questions you may have about where to obtain study material. The training petty officer usually issues you your PQS material and maintains the associated progress chart.

### Educational Services Officer

The ESO maintains the TRAMANS, non-resident training courses (NRTC), and NRTC answer sheets. The ESO can also assist you with off-duty education such as the Scholastic Aptitude Test (SAT) and the College Level Examination

Program (CLEP) tests, as well as enrollment in local colleges.

### **Command Career Counselor**

The command career counselor can assist you in applying for schools, arranging for duty stations in conjunction with GUARD reenlistments, and any other questions you may have about your career path.

## **SUMMARY**

This chapter has covered information of the rating, duties and responsibilities, advancement requirements, and training sources. All these areas are important in their own right. If you wish to advance in the Navy, you should study the OCCSTDs and the publications mentioned in the *Advancement Handbook for Petty Officers*.



## CHAPTER 2

# ADMINISTRATION AND PROGRAMS

As you progress up the ladder of advancement, you will be required to become more and more involved with the administrative portion of your rates. Administration is the machinery by which an organization plans and accomplishes its assigned responsibilities. Experience has demonstrated that the issuance of procedures in writing fosters the use of the best available techniques for administration. Additionally, it provides for uniformity of operations in light of the continuing turnover of personnel within the GSE/GSM ratings.

The Navy has many programs that will affect you at some time in your Navy career. In this chapter you will learn the basics of some of the programs that will affect you as a GSE or GSM. This chapter is not designed to make you an expert in any of these programs, rather it will make you aware of their existence and advise you where to seek more in-depth information. Programs we discuss include only those you will need to know about while carrying out your assigned duties.

After studying this chapter, you should be able to identify and locate the publications, blueprints, catalogs, charts, directives, drawings, manuals, and schematics you will need to perform your day-to-day tasks. You should be able to describe the proper procedures for submitting work deferrals, completions, and maintenance data system forms. Also, you should be able to recognize the various types of logs and records and explain how they are maintained and why they are kept. You should be able to discuss with some accuracy the various programs pertinent to you as an engineer (that is, safety, equipment tag-out, personnel protection, fluid management, physical security, environmental quality, gauge calibration, and valve maintenance); understand how the Personnel Qualifications Standards (PQS) program will mold you into a more competent watch stander; and discuss the function of the Main Space Fire

Doctrine and how it interacts with the Engineering Operational Sequencing System (EOSS).

### SOURCES OF INFORMATION

One of the most useful things you can learn about a subject is how to find out more about it. No single publication can give you all the information you need to perform the duties of your rating. You should learn where to look for accurate, authoritative, up-to-date information on all subjects related to engineering administration and engineering programs. In this section we will discuss most of the publications you will use. These publications contain the detailed information you need for advancement and for everyday work. Some are subject to change or revision from time to time—some at regular intervals, others as the need arises. When using any publication that is subject to change or revision, be sure you have the latest edition. When using any publication that is kept current by changes, be sure you have a copy in which all official changes have been made. Studying canceled or obsolete information will not help you to do your work or to advance in rate. At best, it is a waste of time; at worst, it may be dangerously misleading.

### NAVAL SEA SYSTEMS COMMAND PUBLICATIONS

The publications issued by the Naval Sea Systems Command (NAVSEA) are of particular importance to engineering department personnel. They disseminate authoritative information concerning equipment operation and technical or safety matters requiring immediate fleet implementation. They also provide the status of selected technical/logistic issues for the various classes of ships. Although you do not need to know everything in these publications, you should have a general idea of their content.



The *Naval Ships' Technical Manual (NSTM)* is the basic engineering doctrine publication of NAVSEA. NAVSEA keeps the manual up-to-date by quarterly changes. When NAVSEA issues new or revised chapters, they designate them with a new chapter numbering system.

The following chapters of the *Naval Ships' Technical Manual* are of particular importance to GSEs and GSMs; they reflect the new and old numbers for each chapter.

| <u>NEW</u>    | <u>OLD</u> | <u>CHAPTER</u>  |
|---------------|------------|---|
| 078           | (9950)     | Gaskets, Packings, and Seals  |
| 220,<br>Vol 2 | (9560)     | Boiler Water/Feedwater - Test and Treatment   |
| 221           |            | Boilers   |
| 234           | (9416)     | Marine Gas Turbines   |
| 241           | (9420)     | Propulsion Reduction Gears, Couplings, and Associated Components                        |
| 243           | (9430)     | Shafting, Bearings, and Seals   |
| 244           | (9431)     | Bearings  |
| 245           | (9440)     | Propellers  |
| 254           | (9460)     | Condensers, Heat Exchangers, and Air Ejectors   |
| 255           | (9562)     | Feedwater System and Apparatus  |
| 262           | (9450)     | Lubricating Oils, Greases, and Hydraulic Fluids and Lubrication Systems                 |
| 300           | (9600)     | Electric Plant General  |
| 302           | (9630)     | Electric Motors and Controllers   |
| 491           | (9690)     | Electric Measuring and Test Instruments   |
| 503           | (9470)     | Pumps   |
| 504           | (9870)     | Pressure, Temperature, and Other Mechanical and Electromechanical Measuring Instruments |
| 505           | (9480)     | Piping Systems  |
| 541           | (9550)     | Ship Fuel and Fuel Systems  |

## MANUFACTURERS' TECHNICAL MANUALS

Another important source of information you can use is the manufacturer's technical manual for the piece of equipment you are working on. These manuals contain all the information necessary for operation, troubleshooting, overhaul, and repair. For example, they contain information on gas turbine engine (GTE) component change-out and engine change-out.

## DRAWINGS

Some of your work as a GSE/GSM will require you to read and work from mechanical drawings. You can find information on how to read and interpret drawings in *Blueprint Reading and Sketching*, NAVEDTRA 12014.

Besides knowing how to read drawings, you must know how to locate applicable drawings. For some purposes, the drawings included in the manufacturers' technical manuals for the machinery or equipment may give you the information you need. In many cases, however, you may have to consult the onboard drawings. The onboard drawings are sometimes referred to as ship's plans or ship's blueprints. An index called the ship's drawing index (SDI) lists the onboard drawings. The SDI lists all working drawings that have a NAVSHIPS drawing number, all manufacturers' drawings designated as certification data sheets, equipment drawing lists, and assembly drawings that list detail drawings. The SDI identifies the onboard drawings by an asterisk (\*).

Drawings are listed in numerical order in the SDI. Onboard drawings are filed according to numerical sequence. Two types of numbering systems are in use for drawings with NAVSHIPS numbers. The older system is an S-group numbering system. The newer system, used on all NAVSHIPS drawings since 1 January 1967, is a consolidated index numbering system. A cross-reference list of S-group numbers and consolidated index numbers is given in *NAVSHIPS Consolidated Index of Materials and Services Related to Construction and Conversion*.

## SHIPS' MAINTENANCE AND MATERIAL MANAGEMENT (3-M) SYSTEMS

The *Ships' Maintenance and Material Management (3-M) Manual*, OPNAVINST 4790.4, describes in detail the Ships' 3-M Systems. The

primary objective of the Ships' 3-M Systems is to provide for managing maintenance and maintenance support in a way to ensure maximum equipment operational readiness. The Ships' 3-M Systems is divided into two subsystems. They are the Planned Maintenance System (PMS) and the Maintenance Data System (MDS).

### **PURPOSES OF PMS**

The PMS was established for several purposes:

1. To reduce complex maintenance to simplified procedures that are easily identified and managed at all levels
2. To define the minimum planned maintenance required to schedule and control PMS performances
3. To describe the methods and tools to be used
4. To provide for the detection and prevention of impending casualties
5. To forecast and plan manpower and material requirements
6. To plan and schedule maintenance tasks
7. To estimate and evaluate material readiness
8. To detect areas requiring additional or improved personnel training and/or improved maintenance techniques or attention
9. To provide increased readiness of the ship

### **BENEFITS OF PMS**

The PMS is a tool of command. By using PMS, the commanding officer can readily determine whether his ship is being properly maintained. Reliability and availability are improved. Preventive maintenance reduces the need for major corrective maintenance, increases economy, and saves the cost of repairs.

The PMS assures better records because the shipboard maintenance manager has more useful data. The flexibility of the system allows for programming of inevitable changes in employment schedules. This helps to better plan preventive maintenance,

The PMS helps leadership and management reduce frustrating breakdowns and irregular hours of work, and thus improves morale. It enhances the effectiveness of all hands.

### **LIMITATIONS OF PMS**

The PMS is not self-starting; it does not automatically produce good results. It requires considerable professional guidance and continuous direction at each level of the system's operation. One individual must have both the

authority and the responsibility at each level of the system's operation.

Training in the maintenance steps as well as in the system is necessary. No system is a substitute for the actual, technical ability required of the petty officers who direct and perform the upkeep of the equipment.

### **CURRENT SHIP'S MAINTENANCE PROJECT**

The Current Ship's Maintenance Project (CSMP) is a numerical listing of outstanding deficiencies for all work centers aboard ship. Previously, an appropriate shore facility prepared and distributed the CSMP. However, because of deployment schedules and delays in mailing, the CSMP did not reflect the actual status of completed actions. Now, with the introduction of a 3-M computer system, most ships can prepare and update their own CSMP and deliver it on tape to the appropriate shore facility.

As a third class petty officer, you prepare forms for deferred maintenance actions and/or work requests. If a problem arises with a piece of equipment that cannot be repaired within 30 days, you must prepare a deferred action. If the problem is beyond a ship's force capability to repair, you have to prepare a deferred action/work request. It is very important that you maintain a timely and accurate account for trend analysis so supervisors can organize effective work schedules.

Because of rapid changes in the Ships' 3-M Systems, always refer to a current copy of the *Ships' Maintenance and Material Management (3-M) Manual*.

### **ENGINEERING ADMINISTRATION**

In this section we will discuss the portions of engineering administration pertinent to you as a third class GSE or GSM, such as the *Engineering Department Organization and Regulations Manual (EDORM)*, logs and records, programs, the Personnel Qualification Standards (PQS), the Main Space Fire Doctrine, and the EOSS.

### **EDORM**

The *EDORM* is a joint type-commander instruction (COMNAVSURFLANTINST 3540.18 and COMNAVSURFPACINST 3540.14) that is usually modified by each ship to suit the ship's special requirements. You should refer to it for matters pertaining to the organization,

management, operation, and readiness of the engineering department.

### STANDING/NIGHT ORDERS

The various operating orders that you must become familiar with include standard (or standing) orders, standing orders for special evolutions, and night orders.

One of the commanding officer's standing orders specifically pertaining to the engineering department is the Restricted Maneuvering Doctrine. This is an instruction that is reviewed by each new commanding officer and approved or revised to his own requirements. It includes main engine combinations, generator combinations, standby setups, and casualty procedures to use during

| ENGINEERING LOG  |                                 |           |                                    |                              | (9.77 EDITION IS OBSOLETE) |                               | CLASSIFICATION |      |
|--|---------------------------------|-----------|------------------------------------|------------------------------|----------------------------|-------------------------------|----------------|------|
| NAVSEA 3120/2B (REV. 10-81) S/N 0116-LF-031-2115                     |                                 |           |                                    |                              |                            |                               |                |      |
| U.S.S.   |                                 |           |                                    |                              |                            |                               | HULL NUMBER    |      |
| DAY  | MONTH                           | YEAR      | TIME ZONE                          | TIME ZONE CHANGE TO          |                            | TIME ZONE CHANGE FROM         |                |      |
| AT/PASSAGE FROM  |                                 |           |                                    | PASSAGE TO                   |                            | TOTAL MILES TRAVELED TODAY    |                |      |
| EQUIPMENT STATUS <i>(Need not be completed for continuing pages)</i> |                                 |           |                                    |                              |                            |                               |                |      |
| MAIN ENGINES   |                                 |           | PLANT STATUS                       |                              |                            | BOILERS                       |                |      |
| GENERATORS   |                                 |           |                                    | STEERING ENGINES COMBINATION |                            |                               |                |      |
| DAYS OUT OF DRY DOCK   |                                 |           | CATAPULT STATUS <i>(CV's Only)</i> |                              |                            | DAYS SINCE LAST HULL CLEANING |                |      |
| DRAFT FWD  |                                 | DRAFT AFT |                                    | DRAFT MEAN                   |                            | TONS                          |                |      |
| LIQUID LOAD  |                                 |           |                                    | PERCENT OF FULL LOAD (%)     |                            |                               |                |      |
| MAJOR EQUIPMENT OUT OF COMMISSION                                    |                                 |           |                                    |                              |                            |                               |                |      |
| EXAMINED DAILY AND CERTIFIED TO BE CORRECT                           |                                 |           |                                    |                              |                            |                               |                |      |
| SIGNATURE OF ENGINEER OFFICER/RANK                                   |                                 |           |                                    |                              |                            | DATE OF SIGNATURE             |                |      |
| TIME   | RECORD OF ALL EVENTS OF THE DAY |           |                                    |                              |                            | DAY                           | MONTH          | YEAR |
|  |                                 |           |                                    |                              |                            |                               |                |      |
|  |                                 |           |                                    |                              |                            |                               |                |      |
|  |                                 |           |                                    |                              |                            |                               |                |      |
|  |                                 |           |                                    |                              |                            |                               |                |      |
|  |                                 |           |                                    |                              |                            |                               |                |      |
| CLASSIFICATION   |                                 |           |                                    |                              |                            |                               | PAGE NO.       |      |
| (Leave back side blank)  |                                 |           |                                    |                              |                            |                               |                |      |

Figure 2-1.—Engineering Log, NAVSEA 3120/2B.



location or route of the ship; and remarks chronicling important events.

Entries made in the Engineering Log must follow instructions given (1) on the Engineering Log-Instructions, NAVSEA 3120/2D (fig. 2-3),

(2) in chapter 10 of U.S. *Navy Regulations*, (3) in chapter 090 of *Naval Ships' Technical Manual*, and (4) in directives from the type commander.

Remarks written in the Engineering Log must include (1) personnel casualties (injuries),

|   |  |                              |
|---|--|------------------------------|
| <b>ENGINEERING LOG-INSTRUCTIONS</b><br>NAVSEA 3120/2D (REV. 10-81) S/N 0116-LF-031-2125   | (9-77 EDITION)<br>IS OBSOLETE  | <b>FOR OFFICIAL USE ONLY</b> |
| <b>ENGINEERING LOG INSTRUCTIONS FOR ALL SURFACE SHIPS</b>   |  |                              |
| <b>Instructions For Keeping The<br/>         Engineering Log - Title Page, Form NAVSEA 3120/2A (Rev. 10-81);<br/>         Engineering Log, Form NAVSEA 3120/2B (Rev. 10-81); Engineering<br/>         Log - Continuation, Form NAVSEA 3120/2C (Rev. 10-81); Engineering<br/>         Log - Instructions, Form NAVSEA 3120/2D (Rev. 10-81)</b>   |  |                              |
| <b>(For All Surface Ships)</b>  |  |                              |
| <p>1 The Engineering Log shall be maintained in accordance with Art. 0724 of Navy Regulations, and Section 423 of OPNAVINST 3120 32A. It shall be neatly written in pen or pencil. The original writing is the legal record and must be preserved. It is not desired that the log be recopied except when one or more pages are sent away from the ship. A reproduced copy will then be used.</p> <p>2 If the information in the sheet is classified, fill in the classification of the log sheet at the top and bottom in the spaces provided. (For example: Classified by OPNAVINST 3063. Review By: 1 Mar 1992)</p> <p>3 Fill out the data cover sheet, form NAVSEA 3120/2A.</p> <p style="margin-left: 20px;">a Page numbering shall be completed with the number on the last page of the last day of the month.</p> <p style="margin-left: 20px;">b Examined and approved signatures are completed at the end of the month.</p> <p>4 Complete the log. All unused blanks shall be crossed out. Do not erase. All errors shall be lined out, initialed, and dated by the person making the original entry.</p> <p style="margin-left: 20px;">a Fill in the heading. Fill in the total miles traveled at the end of the day.</p> <p style="margin-left: 20px;">b Fill in the equipment status section. This section must be completed on the first page of each day only. Continuation sheets will be used when required.</p> <p style="margin-left: 40px;">(1) Main engines - Enter engines which are in use. (If a single engine ship, enter number one.)</p> <p style="margin-left: 40px;">(2) Plant status - Enter split/cross-connected/cold iron/auxiliary/modified main, etc.</p> <p style="margin-left: 40px;">(3) Boilers - Enter boilers which are on the line.</p> <p style="margin-left: 40px;">(4) Generators - Enter SSTG/SSDG which are on the line and in parallel operation, e.g., 1 and 2, 4 and 6, ....</p> <p style="margin-left: 40px;">(5) Steering engines combination - Enter both unit (motor) and cable.</p> <p style="margin-left: 40px;">(6) Enter the number of days out of dry dock.</p> <p style="margin-left: 40px;">(7) Enter catapults which are operating and from which spaces each is being provided with steam, e.g., 1/2, 2/4, 3/2, 4/3.</p> <p style="margin-left: 40px;">(8) Enter the number of days since the last hull cleaning.</p> <p style="margin-left: 40px;">(9) Enter the draft readings when in port. When underway, enter the percentage of liquid load (in gallons), fuel (including aircraft if applicable) and water (including ballast and list control if applicable). Then, calculate the draft from the percent of full load, which shall include ammunition and food.</p> | <p style="margin-left: 20px;">(10) Major equipment out of commission (OOC): Enter engines, boilers, SSTG/SSDG, emergency generators, steering gear and combinations of major auxiliary equipment which cause main machinery to be OOC, e.g., # 1A and B lube oil service pumps, or # 2A and B FDB, etc. The intent of this section is to list only those components which affect the overall operation of the ship by placing a limitation on the performance or flexibility of the ship. If space is not sufficient to make all entries, they shall be continued in the section "RECORD OF EVENTS OF THE DAY."</p> <p style="margin-left: 20px;">c Examined daily and certified to be correct. This section shall be examined, verified as correct and signed by the Engineering Officer at the end of each day.</p> <p style="margin-left: 20px;">d Page numbers-Pages shall be numbered consecutively with the first day of each month numbered page one. The back of each page shall be left blank.</p> <p style="margin-left: 20px;">e Record the events of the day.</p> <p style="margin-left: 40px;">(1) Remarks shall be entered by watch or days as applicable.</p> <p style="margin-left: 40px;">(2) The remarks shall be a chronological listing of the day's events, each of which shall be written at the time of occurrence. The following is a complete listing of all requirements generated by the chain of command above the Type Commander level. If Type Commanders desire to increase the recording requirements, an instruction shall be published in the 3100 series including all additional requirements.</p> <p style="margin-left: 40px;">(a) Personal casualties</p> <p style="margin-left: 40px;">(b) Equipment casualties</p> <p style="margin-left: 40px;">(c) Shifting of major equipment</p> <p style="margin-left: 40px;">(d) Changing to and from maneuvering combinations</p> <p style="margin-left: 40px;">(e) Beginning and ending major evolutions: General Quarters, refueling, entering port, etc.</p> <p style="margin-left: 40px;">(f) Change in catapult status (CV only)</p> <p style="margin-left: 40px;">(g) Shifting lube oil strainers</p> <p style="margin-left: 40px;">(h) Opening and inspecting main engines, generators and boilers, and any changes made therein.</p> <p style="margin-left: 40px;">(i) Setting safeties on boilers</p> <p style="margin-left: 40px;">(j) Disposition and changes in principal auxiliaries which affect main machinery operation.</p> <p>5 The Engineering Log may be destroyed 3 years after the date of the last entry. When a ship is stricken, current logs must be forwarded to the nearest Records Management Center.</p> |                              |
| <b>FOR OFFICIAL USE ONLY</b>  |  |                              |

Figure 2-3.—Engineering Log-Instructions, NAVSEA 3120/2D.

(2) equipment casualties, (3) changes in equipment status, (4) changing to or from maneuvering combinations, and (5) such other matters as specified by competent authority. You must write each entry at the time the event occurred. Use standard Navy phraseology, and write each entry as a complete statement.

Type commanders may increase the recording requirements. Instructions on these increased requirements will be published by written directives from the type commanders.

The original Engineering Log, prepared neatly in black ink or pencil, is the legal record. The engineering officer of the watch (EOOW) (under

way) or the engineering duty officer (EDO) (in port) will prepare and sign the remarks. You may not make erasures in the log. Make corrections with a single line drawn through the original entry so that it remains legible. Then write the correct entry. Only the person required to sign the log for that watch can make corrections, additions, or changes, and that person must initial the margin of the page.

The engineer officer reviews the log daily for completeness and accuracy and signs it in the space provided. The commanding officer approves and signs the Engineering Log-Title Page, NAVSEA 3120/2A (fig. 2-4), on the last

| ENGINEERING LOG-TITLE PAGE<br>NAVSEA 3120/2A (REV. 10-81) S/N 0118-LF-001-2110 |  | NAVSEA 3120/2 (P-77)<br>IS OBSOLETE | FOR OFFICIAL USE ONLY |
|--|--|-------------------------------------|-----------------------|
| <h1>ENGINEERING LOG</h1>   |  |                                     |                       |
| U.S.S. _____   |  |                                     |                       |
| HULL NUMBER _____  |  |                                     |                       |
| FOR MONTH OF: _____  |  |                                     |                       |
| FOR YEAR OF: _____   |  |                                     |                       |
| CONSISTING OF PAGES 1 THROUGH _____  |  |                                     |                       |
| EXAMINED DAILY AND CERTIFIED TO BE CORRECT:                                    |  |                                     |                       |
| SIGNATURE OF ENGINEER OFFICER/RANK   |  | DATE OF CERTIFICATION               |                       |
| APPROVED BY:   |  |                                     |                       |
| SIGNATURE OF COMMANDING OFFICER/RANK   |  | DATE APPROVED                       |                       |
| FOR COMPLETION UPON CHANGE OF COMMAND  |  |                                     |                       |
| SIGNATURE OF COMMANDING OFFICER BEING RELIEVED/RANK                            |  | DATE OF CHANGE OF COMMAND           |                       |
| PRINTED NAME OF COMMANDING OFFICER BEING RELIEVED                              |  |                                     |                       |
| TO BE RETAINED ON BOARD 3 YEARS  |  |                                     |                       |
| FOR OFFICIAL USE ONLY  |  |                                     |                       |

Figure 2-4.—Engineering Log-Title Page, NAVSEA 3120/2A.

calendar day of each month and on the day he relinquishes command.

The ship maintains completed Engineering Log sheets in a ring or post binder and retains them on board for 3 years. Personnel making entries in the Engineering Log number the pages consecutively. A new series of page numbers commences on the first day of each month.

**Engineer's Bell Book**

The Engineer's Bell Book, NAVSHIPS 3120/1, shown in figure 2-5, is a record of all orders received by the station in control of the throttles regarding a change in the movement of the propellers. The throttle operator (or assistant) makes entries as soon as he receives an order. An assistant may make entries when the ship is in a special maneuvering situation that may call for

numerous or rapid speed changes. This allows the throttle operator to give complete attention to answering the bells.

All entries made in the Engineer's Bell Book must follow the Instructions for Keeping the Engineer's Bell Log, NAVSEA 3120/1 (8-85). It is maintained in the following manner:

1. Use a separate bell sheet for each shaft each day. When a station controls more than one shaft, use the same sheet for all shafts controlled by that station.
2. Record the time the order was received in column 1 (fig. 2-5).
3. Record the order received in column 2. Record minor speed changes by entering the revolutions per minute (rpm) or pitch change

ENGINEER'S BELL BOOK ALL VESSELS  
NAVSEA 3120/1 (Rev. 8-85)

### ENGINEER'S BELL BOOK



SHIP TYPE  
HULL NUMBER

1 2 3 4 5 6 7

SHEET SERIAL  
YEAR  
MONTH  
ZONE  
DAY

10 11 12 13 14 15 16 17

Ship Name

J

SHAFT NUMBER(S)  
CLASS  
HANDL.

74 77 78 79

Record of all BELLS, SIGNALS, and ORDERS received regarding movement of propellers this date.

En route from \_\_\_\_\_ to \_\_\_\_\_ Clocks set back or ahead \_\_\_\_\_ hrs. \_\_\_\_\_ min. at \_\_\_\_\_

| (1)<br>TIME | (2)<br>SIGNAL | (3)<br>R.P.M. | (4)<br>COUNTER<br>OR<br>PITCH SET | (1)<br>TIME | (2)<br>SIGNAL | (3)<br>R.P.M. | (4)<br>COUNTER<br>OR<br>PITCH SET | (1)<br>TIME | (2)<br>SIGNAL | (3)<br>R.P.M. | (4)<br>COUNTER<br>OR<br>PITCH SET |
|-------------|---------------|---------------|-----------------------------------|-------------|---------------|---------------|-----------------------------------|-------------|---------------|---------------|-----------------------------------|
| 18 21       | 24 28         | 29 32         | 33 38                             | 18 21       | 24 28         | 29 32         | 33 38                             | 18 21       | 24 28         | 29 32         | 33 38                             |
|             |               |               |                                   |             |               |               |                                   |             |               |               |                                   |
|             |               |               |                                   |             |               |               |                                   |             |               |               |                                   |
|             |               |               |                                   |             |               |               |                                   |             |               |               |                                   |
|             |               |               |                                   |             |               |               |                                   |             |               |               |                                   |
|             |               |               |                                   |             |               |               |                                   |             |               |               |                                   |
|             |               |               |                                   |             |               |               |                                   |             |               |               |                                   |
|             |               |               |                                   |             |               |               |                                   |             |               |               |                                   |



S/N 0116-LF-031-2001

Figure 2-5.—Engineer's Bell Book, NAVSHIPS 3120/1.

ordered. Record major speed changes using the following symbols:

1/3—ahead 1/3 speed

2/3—ahead 2/3 speed

I—ahead standard speed

II—ahead full speed

III—ahead flank speed

Z—stop

B1/3—back 1/3 speed

B2/3—back 2/3 speed

BF—back full speed

BEM—back emergency speed

4. Enter the rpm corresponding to the major speed change ordered in column 3. When the order is a minor speed change of rpm only, make no entry in column 2.

5. Record the pitch set in feet (FFG-7 class) or percent (DD-963/DDG-993/CG-47 classes) in column 4.

Before going off watch, the throttle operator and the EOOW sign the log on the two lines following the last entry. The next watch continues the record.

When control is at the ship control console (SCC) on the bridge, bridge personnel maintain the Engineer's Bell Book; when control is at the central control station (CCS), the CCS personnel maintain the Engineer's Bell Book. Engine-room personnel maintain the Engineer's Bell Book if throttle control is maintained in the engine room.

You cannot make alterations or erasures in the Engineer's Bell Book. Correct errors in the Engineer's Bell Book in the same manner as the Engineering Log, by drawing a single line through the incorrect entry and recording the correct entry on the following line. The EOOW, officer of the deck (OOD), or watch supervisor, as appropriate, will initial corrected entries.

### **Automatic Bell Log**

On DD-963, DD-993, and CG-47 class ships, the automatic bell logger printout (Automatic Bell

Log) is also a legal record. At the end of each watch, the EOOW signs the automatic printouts in the same manner as the Engineer's Bell Book. When the automatic bell logger and/or the data logger are in operation, all bells are automatically logged. Unless specified by local instructions, you are not required to maintain a bell book on the DD-963, DD-993, and CC-47 class ships.

### **Equipment Operating Logs**

Watch standers are required to maintain a variety of handwritten machinery logs. Each command prepares its own logs. They cover equipment designated by the type commanders, squadron commanders, and your own command. Items generally covered include waste heat boilers (WHBs), gas turbine generators (GTGs), air compressors, reduction gears, and line shaft bearings (LSBs). As each command has different requirements, the list of logs maintained will vary.

All equipment operating logs have high- and low-limit set points printed for each reading. The person maintaining the logs circles in red all out-of-limits readings. Entries in the remarks section of the logs note the reason for the out-of-limits condition and the action taken to correct the condition. At the end of each watch, the EOOW should review and initial all of the logs maintained on his watch.

### **PROGRAMS**

Engineering petty officers are normally responsible for a myriad of administrative programs. You will use these programs to manage and record inspections, tests, maintenance, safety, liquid systems, and repairs. No one program is more important than another, but some require more time and paper work. You must keep on top of each one of these programs to have a successful administrative organization.

The administrative programs include safety programs, equipment maintenance and repair programs, and management programs. Some of the programs we discuss may overlap into two or three areas. For our purposes, we will discuss them in their major group.

#### **Safety Program**

The objective of the Navy's Safety Program is to enhance operational readiness by reducing the frequency and severity of on- and off-duty mishaps to personnel and the cost of material and



property damage attributed to accidental causes. The use of the term *Safety Program* in this chapter signifies both occupational safety and health.

Operating personnel must be thoroughly familiar with the technical manuals and other publications concerning equipment under their care. Operating personnel must continuously exercise good judgment and employ common sense in the preparation, setting-up, and operation of all engines to prevent damage to the engines and injury to personnel.

Personnel can prevent damage to machinery by properly preparing and operating the equipment; by following instructions and procedures outlined in the EOSS (which is discussed in the last section of this chapter); by observing cleanliness in handling all parts of the engine, lubricating oils, and fuel oils; and by being completely familiar with all parts and functions of the machinery.

You can prevent damage to the ship by operating the machinery so no loss of power occurs at an inopportune time, by keeping engines ready for service in any emergency, and by preventing hazardous conditions that may cause fire or explosion. Always maintain fire-fighting equipment in a "ready to use" state.

You can prevent injury to personnel by having a thorough knowledge of duties, by knowing how to properly handle tools and operate equipment, by observing normal precautions around moving parts, and by receiving constant training.

Other everyday safety habits that you should follow include (1) maintaining clean fuel, air, coolants, lubricants, and operating spaces; (2) preventing the accumulation of oil in the bilges or other pockets or foundations and subbases; (3) taking care, particularly when on an uneven keel, that water in the bilges does not reach electrical machinery or wiring; and (4) ensuring that safety guards are provided at exposed danger points.

**SPECIFIC GAS TURBINE SAFETY PRECAUTIONS.**—In the interest of personnel and machinery safety, you must adhere to the following safety precautions specifically related to the gas turbine:

1. Do not attempt to operate equipment by overriding automatic shutdown or warning devices.
2. Disconnect batteries or other sources of electrical power before performing maintenance.

This prevents injuries from short circuits and accidental cranking of engines.

3. Avoid holding or touching spark plugs, ignition units, or high-tension leads while they are energized.

4. When turning an engine by hand, use standard safety procedures to prevent injuries to fingers or hands.

5. Retain adequate speed control of the power turbine (PT) by keeping the fuel control and speed control governors connected. When operating or starting an engine, do not, under any circumstances, disconnect the governors.

6. Do not use oxygen to pressure test fuel lines and equipment.

7. Do not use compressed air to spin ball or roller bearings after cleaning them.

8. Take precautions to avoid inhaling vapors of lacquer thinner, trichlorethylene, and similar solvents.

9. Avoid changes to the high-speed stop on the fuel control and adjustments to the speed control governors. If you have to make adjustments, follow the appropriate technical manual procedure.

10. Follow the appropriate guides in the NAVSEA technical manuals for making periodic inspections and testing the safety control circuits and automatic shutdown devices.

11. Do not wear jewelry and watches while working on GTEs.

12. Take precautions to avoid touching exposed hot parts of the engine. Do not perform maintenance work until the engine has been shut down and cooled.

13. To protect against personnel or fire hazards, ensure that all thermal insulation and/or shields are intact and sound.

14. If a false start occurs, always purge the engine using the EOSS procedure. This is very important and cannot be overemphasized.

15. Make certain that the combustor drains operate freely. Do not allow fuel to accumulate in the combustion chamber prior to light-off. Later firing could cause a hot start.

16. Wear proper ear protection in the engine room while GTEs are in operation.

17. Ensure all ducting permits free flow. Air intake and exhaust openings must allow unrestricted flow of the gas. The performance of gas turbines drops off quite rapidly with increased duct losses.

18. Always test overspeed trips and governor mechanisms by following instructions in the manufacturers' technical manuals. Never test the overspeed trip by manually overriding the speed control governor. When the overspeed trip does not function properly, no overspeed protection exists.

**ELECTRICAL SAFETY.**—The prevention of accidents is possible. It is your job to recognize unsafe conditions and correct them. Observing safety precautions helps keep your equipment operating, helps your career in the Navy, and possibly determines whether or not you survive.



**ZAP!**

It takes one minute to write a safety rule  
One hour to hold a safety meeting  
One week to plan a safety program  
One month to put a plan into operation  
One year to win a safety award  
*BUT* it takes just one second to destroy  
all this with a mishap.

**DON'T GET  
TURNED ON  
BY ELECTRICITY!**

CBS GS 5R7  
Navy Safety Office  
NAS, Norfolk, VA



**Think safety.** No person is safer than the most careless act performed. Safety is stressed in numerous places throughout this training manual. For a more complete reference of detailed safety precautions, refer to *Naval Ships' Technical*

*Manual*, chapters 300 and 400; OPNAVINST 3120.32, *Standard Organization and Regulations of the U.S. Navy (SORM)*; and OPNAVINST 5100.19, *Safety Precautions for Forces Afloat*.

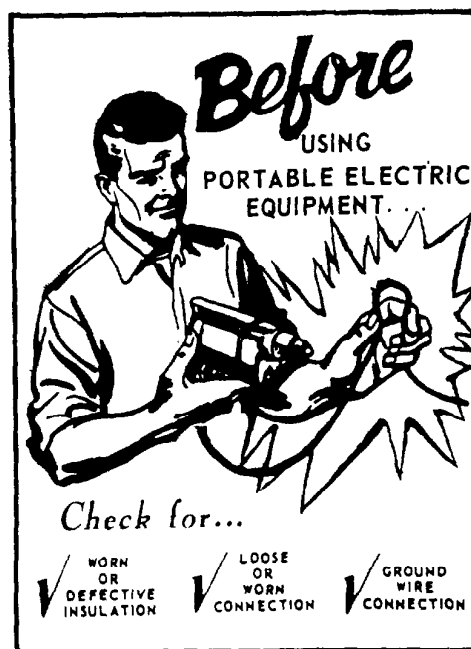
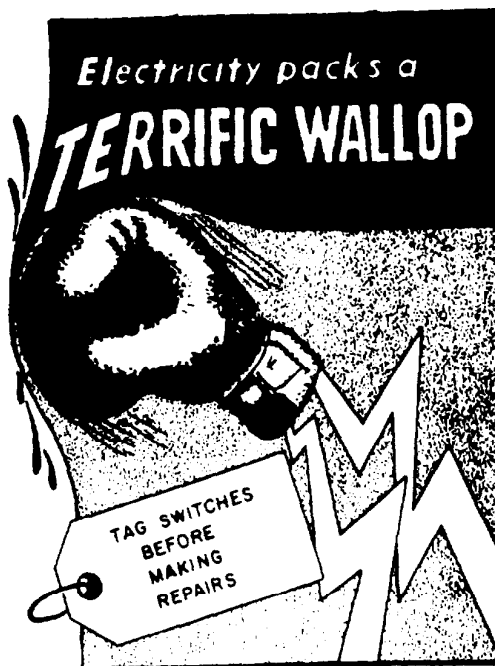
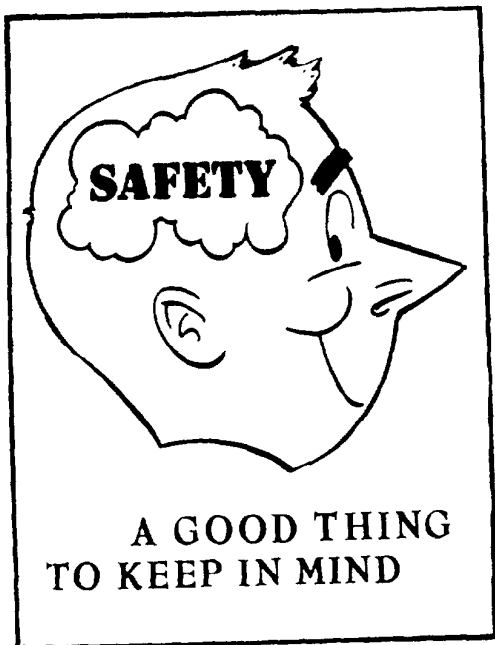

Figure 2-6.—Safety posters.

**Electrical Hazards and Precautions.**—You must recognize hazardous electrical conditions and take immediate steps to correct them. Safety posters (figs. 2-6 and 2-7) help warn of dangers in working areas or help remind you to be safety

conscious. Warning signs (red) and caution signs (yellow) located where hazardous conditions exist help promote safety.

The danger of shock from the 450-volt alternating current (ac) ship's service system is well

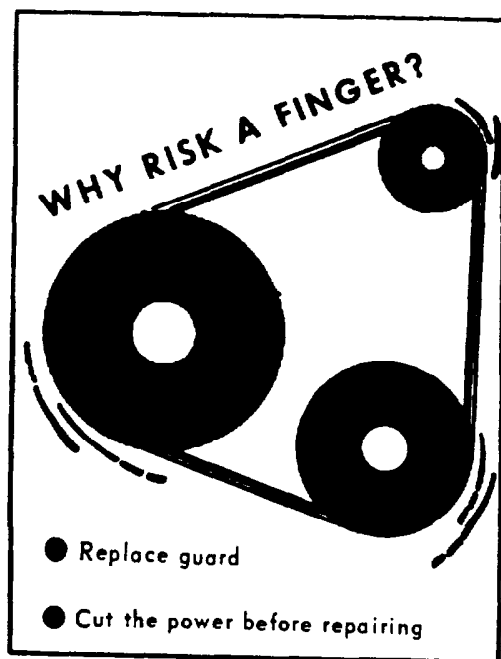
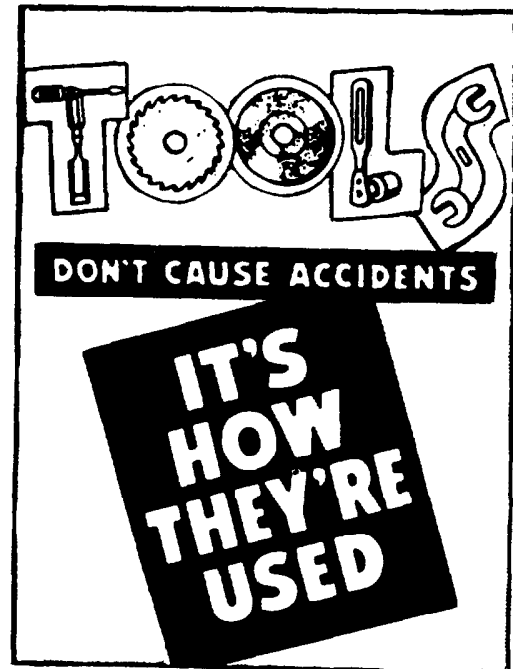

Figure 2-7.—Safety posters.

recognized by operating personnel in the fleet. This is shown by the relatively few reports of serious electrical shock received from this voltage, despite its widespread use. However, a number of shipboard fatalities have been reported due to contact with 115-volt circuits. Low-voltage (115 volts and below) circuits are very dangerous and can cause death. This is most likely to occur when the resistance of the body is lowered by moisture and especially when current passes through or across the chest. Extra care and awareness of the hazards associated with normal shipboard conditions must be emphasized. Perspiration and/or damp clothing result in a decrease in the resistance of the human body. Low body resistance along with the ship's metal structure are the breeding grounds for severe electrical shock.

Accidentally placing or dropping a metal tool, a rule, a flashlight case, or any other conducting article across an energized line can cause a short circuit. The arc and fire that may result on even relatively low-voltage circuits can cause extensive damage to equipment and serious injury to personnel.

Since the ship's service power distribution systems are designed to be ungrounded, many personnel believe it is safe to touch one conductor since no electrical current flows. This is not true. If one conductor of an ungrounded system is touched while the body is in contact with the ship's hull or other metal equipment enclosure, a fatal electric current may pass through the body. **TREAT ALL ELECTRIC CIRCUITS AS HAZARDOUS.** Where working conditions warrant it, wear appropriate protective clothing.

Make it a habit to look for and correct defective tools and equipment, improper grounding, and rotating machinery hazards.

**Hand Tools.**—Normally, you should have no problems when working with hand tools. It is entirely possible that you have seen some dangerous practices in the use of hand tools that should have been avoided. One unsafe practice involves the use of tools with plastic or wooden handles that are cracked, chipped, splintered, broken, or otherwise unserviceable. Using such tools will probably result in accidents and personal injuries, such as cuts, bruises, and foreign objects being thrown in the eyes. If unserviceable hand tools are not repairable, discard and replace them. For further instructions on the safe use of hand tools, refer to chapter 3 of this TRAMAN and *Use and Care of Hand Tools and Measuring Tools*, NAVEDTRA 12085.

**Portable Electric Power Tools.**—Portable power tools should be clean, properly oiled, and

in good repair. Before using them, inspect them to see that they are properly grounded. Plug a tool equipped with a three-prong plug only in a three-hole electrical receptacle. Never remove the third prong. Make absolutely sure the tool is equipped with a properly grounded conductor. If the tool has a metal case, be sure to ground it following chapter 300 of *Naval Ships' Technical Manual*. The newer, double-insulated plastic-framed tools do NOT have ground wires and have only a two-prong plug.

Observe all safety precautions when operating any portable electric equipment. Wear rubber gloves whenever plugging into or unplugging from any 115-volt circuit or under particularly hazardous conditions. Some of these conditions include environments such as wet decks, bilge areas, or when working over the side of the ship in rafts or small boats.

Before using any portable electrical equipment, visually examine the attached cable with plug (including extension cords, when used). Tears, chafing, exposed insulated conductors, and damaged plugs are causes for cable or plug replacement. Where PMS is installed, conduct tests following instructions on the maintenance requirement cards (MRCs).

Other safe practices in the use of portable electric power tools include the following:

- Before using the tool, lay all portable cables so you and others cannot trip over them. Normally, the length of extension cords used with portable tools will not exceed 25 feet. Extension cords of 100 feet are authorized on flight and hangar deck areas only. Extension cords of 100 feet are also found in damage control lockers, but are labeled for **Emergency Use Only**.

- Do not use jury-rigged extension cords that have metal "handy boxes" for receptacle ends of the cord. All extension cords must have nonconductive plugs and receptacle housings.

- Do not unplug a cord by yanking on it.

- When making electrical connections, always start at the load and work back to the source. When disconnecting electrical connections, start at the source and work toward the load.

- Stow the tool in its assigned place after you are through using it.

**RESCUE AND FIRST AID FOR ELECTRIC SHOCK.**—Your job is risky even under the best working conditions. Despite the fact that accidents are preventable, you run a good chance of

getting shocked, burned, and being exposed to one or more hazards. If you are at the scene of an accident, you will be expected to assist the victim as quickly as possible.

When a victim is rendered unconscious by electric shock, you should start artificial resuscitation as soon as possible. The only logical permissible delay is that time required to free the victim from contact with the electricity in the quickest, safest way. This step must be done with great care, otherwise there may be two victims rather than one.

If contact is with a portable electric tool, light, appliance, equipment, or portable extension cord, turn off the bulkhead supply switch or remove the plug from its bulkhead receptacle. Clearly warn other persons arriving at the scene not to touch the suspected equipment until it is unplugged. You should seek aid to unplug the device as soon as possible.

Where a victim is in contact with stationary equipment, such as a bus bar or electrical connections, pull the victim free if the equipment cannot be quickly de-energized, or if the ship's operations or survival prevent immediate securing of the circuits. To save time in pulling the victim free, improvise a protective insulation for yourself. For example, instead of hunting for a pair of rubber gloves to use in grasping the victim, you can safely pull the victim free by using your belt a line, or a wooden cane. During the rescue, do not allow any part of your body to directly touch the hull, metal structure, furniture, or victim's skin.

After removing a victim of electric shock from contact with the electricity, he or she may need first aid, cardiopulmonary resuscitation (CPR), or closed-chest cardiac massage. We are not going to discuss these various procedures in this manual. Your ship's corpsman will teach them to you during the annual electrical safety lecture aboard ship.

### **Equipment Tag-Out Program**

An effective tag-out program is necessary because of the complexity of modern ships as well as the cost, delay, and hazard to personnel that

could result from the improper operation of equipment. The purpose of the equipment tag-out program is to provide a procedure to prevent improper operation when a component, equipment, system, or portion of a system is isolated or in an abnormal condition. This procedure should also be used when other safety devices, such as blank flanges, are installed for testing, maintenance, or casualty isolation.

The use of **DANGER** or **CAUTION** tags is not a substitute for other safety measures, such as locking valves, pulling fuses, or racking out circuit breakers. Tags applied to valves, switches, or other components should indicate restrictions on operation of systems or equipment, or restrictions necessary to avoid damage to safety devices. Never use tags for identification purposes.

The procedures in this program are mandatory to standardize tag-out procedures used by all ships and repair activities. The program also provides a procedure for use when an instrument is unreliable or is not in normal operating condition. It is similar to the tag-out procedure except that labels instead of tags are used to indicate instrument status. The tag-out program must be enforced during normal operations as well as during construction, testing, repair, or maintenance. Strict enforcement of tag-out procedures is required by both you and any repair activity that may be working on your equipment.

**RESPONSIBILITY.**—The commanding officer is responsible for the safety of the entire command. It is the duty of the commanding officer to ensure that all personnel know all applicable safety precautions and procedures and to ensure compliance with the program. The engineer officer is responsible to the commanding officer for ensuring that personnel assigned to the engineering department understand and comply with this program.

When repairs are done by a repair activity, a dual responsibility exists for the safety of the repair personnel to ensure that conditions are safe for all work being done. The ship tended is responsible for and controls the tag-out program on the systems that require work. The repair activity is responsible for ensuring compliance with the program.

**PROCEDURES.**—When you identify the need to tag out a piece of equipment or a system, you must get permission from an authorizing officer. The authorizing officer for the engineering department will be the EOOW while under way or the EDO while in port. If the system or equipment tagged is placed out of commission,

the authorizing officer must get permission from the engineer officer and the commanding officer. When permission has been received, the authorizing officer then directs you to prepare the tag-out record sheet and tags.

Normally, the petty officer in charge of the work fills out and signs the record sheet and prepares the tags. The record sheet is filled out for a stated purpose. All tags for that purpose are normally listed on one record sheet. Each sheet is assigned a log serial number. All tags associated with it are given the same log serial number and a sequential number is entered on the record sheet. For example, tag E107-4 is the fourth tag issued on the record sheet with the log serial number 107 for engineering.

The record sheet includes reference to any documents that apply—such as PMS, technical manuals, and other instructions, the reason for the tag-out, the hazards involved, any amplifying instructions, and the work necessary to clear the tags. Use enough tags to completely isolate the system or circuit being worked on to prevent operation from any and all stations that could exercise control. Indicate the location and condition of the tagged item by the simplest means (for example, FOS-11A, closed).

When the tags and record sheets are filled out, a second person must make an independent check of the tag coverage.

When attaching the tags, you must ensure that the item is in the position or condition indicated

|   |   |
|---|---|
| SYSTEM/COMPONENT/IDENTIFICATION   | DATE/TIME                                   |
| SIGNATURE OF PERSON ATTACHING TAG   | SIGNATURE OF PERSON CHECKING TAG            |
| <b>CAUTION</b>  |   |
| DO NOT OPERATE THIS EQUIPMENT UNTIL<br>SPECIAL INSTRUCTIONS ON REVERSE SIDE ARE<br>THOROUGHLY UNDERSTOOD. |   |
| SIGNATURE OF AUTHORIZING OFFICER  | SIGNATURE OF REPAIR ACTIVITY REPRESENTATIVE |
| SERIAL No. <span style="float: right;">NAVSHIPS 9890/5 (REV) (FRONT) FORMERLY NAVSHIPS 9890</span>        |   |

**BLACK LETTERING ON YELLOW TAG**

|  |                              |
|--|------------------------------|
| <b>CAUTION</b>   | NAVSHIPS 9890/5 (REV) (BACK) |
| DO NOT OPERATE THIS<br>EQUIPMENT UNTIL SPECIAL<br>INSTRUCTIONS BELOW ARE<br>THOROUGHLY UNDERSTOOD. |                              |

Figure 2-8.—Caution tag (colored yellow).

on the tag. As you attach each tag, you then must sign the tag and initial the record sheet. After all tags are attached, a second qualified person ensures the items are in the position and condition indicated, verifies proper tag placement, signs the tags, and initials the record sheet.

**TYPES OF TAGS.**—The following is a list of the various tags and the applications required to be used from time to time.

**Caution Tag.**—A **YELLOW** tag (fig. 2-8) is used as a precautionary measure to provide temporary special instructions or to indicate that unusual caution must be exercised to operate

equipment. These instructions must give the specific reason that the tag was installed. The use of such phrases as **DO NOT OPERATE WITHOUT EOOW PERMISSION** is not appropriate since equipment or systems are not operated unless permission has been granted by responsible authority. A **CAUTION** tag is **NOT** used any time personnel or equipment can be endangered while performing evolutions using normal operating procedures; a **DANGER** tag is used in this case.

**Danger Tag.**—A **RED** tag (fig. 2-9) is used to prohibit the operation of equipment that could

|  |                                   |           |   |
|--|-----------------------------------|-----------|---|
| SYSTEM/COMPONENT/IDENTIFICATION  |                                   | DATE/TIME |   |
| POSITION OR CONDITION OF ITEM TAGGED                                       |                                   |           |   |
| <b>SERIAL NO.</b>  | <b>DANGER</b>                     |           |   |
|  | <b>DO NOT OPERATE</b>             |           |   |
|  | SIGNATURE OF PERSON ATTACHING TAG |           | SIGNATURES OF PERSONS CHECKING TAG          |
|  | SIGNATURE OF AUTHORIZING OFFICER  |           | SIGNATURE OF REPAIR ACTIVITY REPRESENTATIVE |
| NAVSHPIS 8898/8 (REV. ) (FRONT) (FORMERLY NAVSHPIS 8000) S/N 0108-041-8000 |                                   |           |   |

BLACK LETTERING ON RED TAG

|   |  |
|---|--|
| <b>DANGER</b>   |  |
| <b>DO NOT OPERATE</b>   |  |
| OPERATION OF THIS EQUIPMENT WILL<br>ENDANGER PERSONNEL OR HARM THE<br>EQUIPMENT. THIS EQUIPMENT SHALL<br>NOT BE OPERATED UNTIL THIS TAG<br>HAS BEEN REMOVED BY AN AUTHOR-<br>IZED PERSON. |  |
| NAVSHPIS 8898/8 (REV. ) (BACK)  |  |

Figure 2-9.—Danger tag (colored red).



jeopardize the safety of personnel or endanger equipment. Under no circumstances should equipment be operated when tagged with **DANGER** tags.

**Out-Of-Calibration Labels.—ORANGE** labels (fig. 2-10) are used to identify instruments that are out of calibration and may not work properly. This label indicates the instrument may be used for system operation only with extreme caution.

**Out-Of-Commission Labels.—RED** labels (fig. 2-11) are used to identify instruments that do not work properly because they are defective or isolated from the system. This indicates the instrument cannot be relied on and must be repaired and recalibrated, or be reconnected to the system before use.

**ENFORCEMENT.**—The tag-out log is kept in a designated space, usually CCS. Supervisory watch standers review the log during watch relief. Active tag-outs are spot checked periodically to ensure tag integrity is being maintained.

An audit of the tag-out log is conducted by the EDO every 2 weeks while in port, prior to getting under way, and weekly if in the yards or at a maintenance availability. Results of the audit are reported to the engineer officer.

To ensure that tag-out procedures are enforced properly, the engineer officer checks the log frequently. If he notes any errors, he brings them to the attention of the proper personnel.

**Personnel Protection Programs**

In this section we will discuss three areas that are of great concern to you as a watch stander. These are heat stress, noise pollution, and handling hazardous materials.

|                                  |      |
|----------------------------------|------|
| <b>OUT OF CALIBRATION</b>        |      |
| SERIAL NO.                       | DATE |
| AUTHORIZED BY/ CONCURRENCE<br>BY |      |
| TAG BY                           | TIME |
| ERROR                            |      |

Figure 2-10.—Out-of-calibration label (colored orange).

|                                  |      |
|----------------------------------|------|
| <b>OUT OF COMMISSION</b>         |      |
| SERIAL NO.                       | DATE |
| AUTHORIZED BY/ CONCURRENCE<br>BY |      |
| TAG BY                           | TIME |

Figure 2-11.—Out-of-commission label (colored red).

**HEAT STRESS.**—While working in hot environments or during strenuous physical work in cool as well as hot ambient conditions, personnel are apt to suffer heat disorders. The results are loss of time from duty and possible death. Many of these illnesses result in prolonged or permanent impairment of the affected person’s ability to withstand heat. Unacclimatized and overweight personnel are particularly susceptible to heatstroke and other heat disorders.

Because of these hazards, exposure of personnel to extended periods of strenuous physical work in spaces of high ambient temperature must conform with NAVMED P-5052-5.

**NOISE POLLUTION.**—Control of noise emission is an important aspect of pollution control. Noise above certain sound levels can cause a wide variety of unwanted effects on personnel, ranging from discomfort and anxiety to illness and deafness. Because of these hazards, exposure of personnel to high sound levels must conform with OPNAVINST 5100.23.

Noise levels generated from GTEs are on the order of 100 to 125 decibels (db). These levels are enough to cause partial or total deafness to unprotected personnel. Three primary noise sources exist in a gas turbine installation. They are (1) the inlet passages, (2) the exhaust ducts, and (3) the engine core.

Noise from the inlet passages and exhaust ducts can be controlled by the installation of acoustic insulation to the structure. Noise from the engine core is controlled by the module surrounding the engine. To prevent negation of the soundproofing characteristics of structural insulation, the insulation must be constantly maintained at a high degree of repair.

Personnel working in an environment where the noise level is greater than 84 db must wear approved hearing protection. If you must be in

an area where the noise level is greater than 104 db (such as running checks on a gas turbine module (GTM) with the module door open), you must wear double hearing protection -earplugs and earmuff protectors.

**HANDLING HAZARDOUS MATERIAL.**—Because of the high rotational speeds and high temperatures generated by GTEs, petroleum-based oils are not suitable for use. Most of today's GTEs use synthetic-based oils containing polyesters. These oils are usually less viscous than those used in reciprocating engines.

The synthetic oil in general use aboard gas turbine ships is MIL-L-23699. You must use special precautions and handling procedures because these oils can remove paint and are toxic. When handling synthetic oils, you must avoid spills. Prolonged contact with the oil can cause skin irritations, such as dermatitis. Inhalation of vapors can cause irritation of the respiratory tract. When working with this oil, you should always wear a face shield, rubber gloves, and an apron. If you do come in contact with synthetic oil, remove any oil-soaked clothing and wash with soap and water. If you have oil splashed into your eyes, immediately flush them with water and seek medical attention.

### **Fluid Management Program**

In this section, we will discuss the receipt, transfer, stowage, and discharge of lube oils. The flammable liquid management program, the analysis of petroleum test results, and the corrective action required for abnormal conditions will also be discussed. You will find that knowledge of fluid management is useful in your day-to-day evolutions and essential to meeting your watch-stander qualifications as oil king. For more specific details and procedures, refer to *Naval Ships' Technical Manual*, chapters 262 and 541.

**LUBE OIL.**—Proper lubrication is vital to the operation of all shipboard machinery. In the following paragraphs we will describe lube oil quality control, the handling of new lube oils and hydraulic fluids (including synthetic oils), and the prevention and clean-up of oil spills.

**Quality Control.**—Each batch of lubricant must be tested, as required by the specifications in effect at the time the batch enters the supply system. Samples of the oils stored in the supply

system must be taken periodically to ensure product quality. When NAVSEA receives reports of lubricant difficulties, it takes immediate steps to determine the problem by testing used and unused lubricant samples and by investigating equipment malfunctions. In this manner, product quality is being maintained and is upgraded when necessary.

**Care of New Lube Oil.**—Upon receiving new lube oil on board ship, and immediately before placing the oil in the storage tanks, you must thoroughly test it using the procedures specified in *Naval Ships' Technical Manual*, chapter 262. Be certain that the proper grade has been delivered and that the oil meets all physical and chemical properties described in the procurement specification. New lube oil should be delivered to ships in a clear and bright condition. If the new oil does not meet the procurement specification, it may have deteriorated or have been contaminated during storage or handling. Shore laboratory testing is required to determine usability.

New oil is delivered to ships either in bulk by tank trucks or as packaged products in drums, pails, or cans. Before off-loading or handling MIL-L-17331 (2190 TEP) tank truck deliveries, sample the oil and visually check all truck compartments. Shore laboratory testing may be required to determine usability. Check for intact seals on commercial trucks and verify delivery documents. If oil quality or quantity is questionable, do not take the oil on board until the problem is resolved with the activity personnel responsible for the delivery. When delivery is by Navy trucks, it should include a laboratory test report of the lube oil quality. Ensure that the truck hose is connected to the correct ship manifold. Upon completion of delivery, sound the lube oil tanks and verify all quantities with the truck meter readings.

Packaged lubricating oil is normally sealed and the containers are marked to identify the content. Do not use the oil if the container markings are not clear. Fifty-five gallon drums are fitted with cap seals on the bungs. If these seals are missing or damaged, do not use the oil until the quality can be verified by shore laboratory analysis. When initially opening a new drum and pail, take a thief sample and visually inspect it for quality. If the sample is contaminated or appears abnormal, isolate the container and do not use until the quality can be established. If other containers show similar quality problems, submit a defective material report (NAVSUPINST 4440.120). Before

using packaged lube oil, you should filter it through a 60-mesh or finer screen. Do not pour oil directly from drums or cans into the operating equipment. Before introducing new or renovated oil into the circulating systems or storage tanks, pass it through an operating centrifugal purifier to remove contaminants.

You will have to maintain specimens of satisfactory oil in properly labeled and corked glass containers. Upon receiving a new supply of oil, take samples for comparison with the specimens of the same brand to make certain that the correct oil has been received. Every oil has definite general characteristics, such as color, odor, and specific gravity, that an experienced engineer may recognize. These specimens are also useful in checking for darkening of in-use oils.

**Precautions Against Oil Spills.**—Any planned industrial process, operation, or product must integrate the prevention of environmental pollution. The preferred method of abatement and control of environmental pollution is at the source of the pollutants.

You should know the potential sources of oil spills and oil waste that may cause pollution if proper procedures are not carried out. The following is a list of common sources of oil and oily waste that find their way into the water:

1. Spillage during fueling, defueling, and internal transfer operations
2. Leakage through hull structure into bilges
3. Stripping from the contaminated oil settling tank
4. Ballast water from fuel tanks of non-compensated fuel systems or bulk carriers
5. Ballast water from compensated fuel tank systems during refueling, defueling, and internal transfer operations
6. Tank cleaning operations
7. Leakage and drainage from equipment and systems
8. Contaminated oil from centrifugal purifiers
9. Used oil from equipment during an oil change

Before any fueling, defueling, or internal transfer operation is started, ensure that all machinery and piping systems have been checked for tightness and signs of leaking glands, seals, and gaskets. When changing oil or adding oil to machinery, take care not to spill the oil into the bilge. Have a drip pan and rags ready for use if needed. Keep a close watch when centrifugal

purifiers are in operation to make sure they do not lose the water seal and dump the oil into the bilge or the contaminated oil tank. During tank cleaning operations, pump all oily waste from the tank into the sludge barge.

Since control of shipboard oil pollution is complicated by the many and varied sources of oily waste, ships have oil pollution control systems. These systems serve to

1. reduce oily waste generation,
2. store waste oil and oily waste,
3. monitor oil and oily waste,
4. transfer or off-load waste oil and oily waste to shore facilities, and
5. process oily waste.

It is the responsibility of the training officers to ensure that formal training is provided to key personnel responsible for maintaining and operating pollution control equipment.

**Reporting and Clean-Up of Oil Spills.**—All oil spills and slicks or sheens within the 50-mile prohibited zone of the United States must be reported immediately in following the provisions of OPNAVINST 5090.1. Ships have been given the capability to provide immediate and remedial action until relieved by shore-based response units or, in the case of non-Navy or foreign ports, to clean up the entire spill. Shore-based units are seldom available in non-Navy or foreign ports.

A cleanup kit has been developed for use by ships' crews. A description of the kit and instructions for its use will be found in the *U.S. Navy Oil Spill Containment and Cleanup Kit, Mark I*, NAVSEA 0994-LP-013-6010. This manual includes safety precautions applicable to the use of the kit, as well as the recommended shipboard allowance. The Navy training film MN-11316 documents and demonstrates the use of the kit on an actual spill. Many times quick reaction by a trained crew can result in the containment of, and often in the collection of, the entire spill without the assistance of shore-based personnel.

**F-76 FUEL OIL (NAVY DISTILLATE).**—Fuel system management involves procedures related to the receipt of fuel and the maintenance of the fuel system equipment. In addition, it involves those procedures that limit the discharge of fuel into the water. Under this topic, we will discuss general requirements for receipt, storage, testing, and tank stripping of F-76 fuel. For more

specific information, refer to *Naval Ships' Technical Manual*, chapter 541.

**Receiving Fuel.**—Just before replenishment, tanks that were ballasted must be tested for water contamination and stripped as necessary. At the beginning, midpoint, and end of replenishment, as a minimum, draw a fuel sample from a test connection and test for bottom sediment and water (BS&W). The maximum allowable BS&W of an acceptable replenishment sample is 0.1 percent. You may use a “clear and bright” appearance during fueling as a secondary indication of acceptable fuel quality pending BS&W determination. You may accept only fuels conforming to MIL-F-16884G (F-76) or, as an alternate, MIL-5624 (JP-5 and F-44). When fueling from NATO sources, you can accept F-75 fuel as an acceptable substitute. F-44 is the NATO designation for JP-5, and F-75 is the NATO designation for fuel that has a lower pour point than F-76. Lighter colored fuels, in general, tend to have less sediment (particulate matter) than darker fuels. They present a lesser filtration burden. Test non-compensated storage tanks for water contamination 24 hours after filling and strip as necessary.

**Service Tank Replenishment.**—You must test nonseawater-compensated fuel storage tanks (from which the service or auxiliary service tank is to be replenished) for water contamination. Before beginning fuel transfer, strip the tanks as necessary. Sample the centrifugal purifier discharge and visually test it 5 minutes after initiation of transfer, and every 30 minutes thereafter. An acceptable sample is one visually determined to be clear and bright. When a sample fails to meet the clear and bright criteria, this indicates a need for tank inspection and/or purifier cleaning.

Recirculate the service tank using the centrifugal purifier for the maximum time available, but no less than 3 hours, or for as many hours as required to recirculate the contents of the service tank. Recirculation reduces the amount of solid contaminants in the fuel.

Fuel contaminants may be less dense, more dense, or as dense as the fuel itself. As a result, one pass through the purifier may remove as much as 50 percent of the incoming contaminants or as little as 10 percent. Multiple passes can eventually remove as much as 90 percent of the total contaminants or at least reduce the level to below that required for engine use. Reducing the level of contamination in the fuel service tank can also result in a reduction in the usage of coalescer and

separator elements and of prefilter elements if they are used. Ensure that the centrifugal purifier bowl is clean. Otherwise, the recirculation will be of little value.

Before placing the standby (or auxiliary) service tank in use, test the tank bottom for water contamination and strip as necessary. Recirculate the propulsion service tank using the centrifugal purifier for the maximum time available.

Sample the filter/separator discharge and test it 5 minutes after a service tank is placed on suction and at least once every 4 hours during system operation. An acceptable sample contains sediment less than 2.64 milligrams per liter (mg/l) and free water less than 40 parts per million (ppm). Failure of the filter/separator to achieve the required fuel quality indicates either the need for coalescer element replacement or insufficient service tank recirculation.

**Tank Stripping.**—At the earliest opportunity, the ship's force must determine (and record) the height of the stripping tail pipe terminus relative to the tank bottom. Stripping of noncompensated tanks is conducted when the water level exceeds the height of the stripping tail pipe. Use a thief sample, water-indicating paste, or a tank stripping sample to determine the water level. Terminate stripping when the water level falls below the stripping tail pipe terminus. This is evidenced by tank bottom testing or when the stripping pump discharge sample does not indicate significant free water.

You must test noncompensated fuel tanks, fuel gravity feed tanks, fuel head tanks, and JP-5 emergency head tank bottoms weekly for the presence of water. Strip them as necessary. In addition, strip these tanks before fuel receipt, transfer, or service.

**F-44 FUEL OIL (JP-5).**—In this section we will discuss the general procedures for receiving, stripping tanks, and testing of F-44 fuel. As a GSE3 or GSM3, you will be involved in one or more of the above procedures on a daily basis. You will note that testing requirements for JP-5 fuel differ somewhat from those of F-76 fuel. While the test equipments used in propulsion fuels are the same, the procedures and criteria are different. The sampling procedures and time requirements also differ.

**Receiving JP-5 Fuel.**—Before and during receipt of JP-5 fuel, take samples in containers that permit visible inspection of the fuel. The criteria for the acceptance or rejection of JP-5 fuel is as follows:

1. A clear, clean sample indicates acceptable JP-5 fuel is being received.

2. If the sample is cloudy, stop the replenishment operation until the source of the cloud is determined by observing the sample.

- If the cloud disappears at the bottom, air is present and the JP-5 fuel is acceptable.

- If the cloud disappears at the top, water is present. In this event, fleet oilers will begin proper stripping and will usually correct cloudiness caused by large amounts of free water.

- If the cloud does not begin clearing in 5 minutes, heat the sample to about 25° above the temperature of the fuel in the tank from which the sample was taken. If the sample clears, the cloud was due only to dissolved water and the JP-5 is acceptable. If the sample does not clear, excessive water is present and you should accept the JP-5 fuel only in an emergency.

3. If the sample contains excessive solid contamination, accept the JP-5 only in an emergency. To make JP-5 that contains excessive amounts of water and/or solids acceptable for aircraft use, you can use the following methods:

- Extend the settling time.
- Meticulously strip the tank.
- Properly use and maintain the centrifugal purifier and the filter/separators in the transfer system and the main service system.

**Stripping Procedures.**—You should continue stripping JP-5 tanks until a sample from the stripping pump outlet indicates all sediment and water in the tanks has been removed. A visual sample is sufficient for storage tank stripping. However, under certain circumstances, you must test service tanks using a free water detector and contaminated fuel detector. For detailed information on requirements for stripping of storage and service tanks, refer to *Naval Ships' Technical Manual*, chapter 542.

**Testing JP-5 Fuel.**—Testing of JP-5 fuel is done at an approved testing laboratory and also

aboard ship. Personnel must take samples for off-ship tests monthly or as ordered if operating conditions permit. Take samples from the following locations:

1. The service filter discharge
2. One nozzle per quadrant

Take samples from the service system filter and fueling station nozzles after the system has been recirculated for at least 2 minutes. Ensure the fuel samples are typical of the fuel delivered to the aircraft. Take samples during aircraft fueling operations.

You must use glass containers of 1 quart minimum size. Ensure the inner cap seal does not contain paraffin, corrosive metal, or other material liable to contaminate fuel. The containers should have noncorrosive, noncontaminating caps to eliminate false or misleading laboratory message reports that could require disruption of fueling from a satisfactory filter.

Thoroughly clean and dry the containers. Inspect them for cleanliness before use. Before sampling JP-5 fuel, rinse the clean container and flush it several times with the fuel being sampled. Then fill it, leaving about a 1/2-inch space for expansion. Cap and mark the glass container immediately. Mark the glass sample container to include all of the following items:

1. Heading: Aviation Fuel Sample
2. Identification of the ship submitting the sample (name and hull number).
3. The fueling station number or service filter/seperator discharge sampled.
4. The type of fuel.
5. The date the sample is drawn.
6. The name of the person drawing the sample.
7. Laboratory instructions: Test for sediment, flash point, and corrosion (if applicable). Notify the ship by message if the sediment contamination exceeds 2.0mg/1, if flash point is below 136°F (57.8°C) or if FSII is less than 0.03 percent. The message should specify items 3, 4, and 6, as well as the sample results. A follow-up routine report of the test results for all samples submitted is requested.
8. Resamples of reported contaminated samples must include the following markings: Resample, request immediate analysis, and the message report.
9. On special samples, outline suspected problems and symptoms.

You must ensure the minimum amount of time possible elapses between sampling and receipt of the report of laboratory analysis. Ships have to use the test results to ensure clean fuel. Schedule routine and monthly sampling for optimum use of available transportation to fuel laboratory locations. Take samples immediately before entering port while the ship's aviation fuel system is in normal operating condition. Deliver the samples by the quickest means possible to the nearest fuel laboratory. For detailed information on the sampling and testing requirements of JP-5 fuel, refer to *Naval Ships' Technical Manual*, chapter 542.

**BOILER WATER/FEEDWATER.**—On ships with WHBs, you may be responsible for testing and treating the WHB with various chemicals to maintain the boiler water within prescribed limits. To be certified for boiler-water and feedwater testing, you must attend school, pass the course, and be certified by your ship's commanding officer as being qualified. In this section we will not attempt to go into detail as to each individual test and requirement, but we will discuss the reasons for treating the WHB and your responsibilities for the necessary tests and administration.

**Shipboard Water Cycle.**—The overall shipboard water cycle is a closed system in which feedwater is fed to the boiler, the water is heated to generate steam, the steam does work, and it is then condensed and returned to the feedwater system. Water for the cycle is obtained from seawater, which is taken into a distiller and evaporated to produce distillate. The distillate is stored in reserve feedwater tanks until needed as makeup feed. When needed to replace system losses, it is pumped to the system. It is then pumped to the deaerating feed tank (DFT), if the ship is so equipped, where oxygen and other gases are removed. This deaerated water, now called feedwater, is pumped to the boiler where heat is applied. The boiler water is converted to steam, and then it is used to operate auxiliary equipment and provide heat energy to different parts of the ship. When most of the heat energy has been removed, the steam is condensed in the condenser. Then it is ready to be recycled once again.

Because the cycle is continuous and closed, the same water remains in the system except for nonrecoverable losses, such as boiler blowdowns, laundry presses, and miscellaneous leaks. Makeup

feedwater is required to compensate for these system losses.

Although the shipboard water cycle is continuous, different terminology is used to describe the water at different points. These distinctions are necessary because water quality standards vary throughout the system. The following terms identify the water at various points:

1. Distillate—The evaporated water that is discharged from the ship's distilling plant. The distillate is stored in the feedwater tanks which are designated as the on-line feed tank and reserve feed tank by the chief engineer.
2. Feedwater—The term used to designate the water stored in the feed tanks.
3. Boiler water—The feedwater becomes boiler water as it enters the boiler and boiler tubes.
4. Condensate—After the steam has done its work, it is returned to its liquid state by cooling in a condenser. The condenser is a heat exchanger in which seawater cools the steam and returns it to liquid form. It is then returned to the feed tank.

**Contamination.**—Boilers cannot be operated safely and efficiently without careful attention to, and control of, feedwater and boiler water quality. With proper control of water chemistry, proper plant operation, and proper lay-up during idle periods, boilers should last the life of the ship with no need to renew boiler tubes. If water conditions are not controlled within allowable limits, rapid deterioration of waterside surfaces, scale formation, and carry-over will occur. This leads to serious boiler casualties. Because boilers concentrate all feedwater contaminants as steam is generated, boiler water quality and reliable boiler operation depend directly upon control of feedwater quality.

Because of ship operations, propulsion systems use water from two sources, seawater and shore water. For boiler operations, these waters are considered contaminated due to various chemicals in them. These chemicals can cause serious boiler failures because of chemical reactions within the boiler. Some of the effects of contamination of boiler water and feedwater are as follows:

1. pH (acidic and caustic corrosion)-Failure to maintain a correct pH balance can cause corrosion. Excessive acidity causes the film on the boiler tube metal to dissolve, resulting in corrosion of the inner tubes of the boiler. Excessive

alkalinity can cause caustic corrosion, which can cause damage as severe as acidic corrosion.

2. Hardness-Calcium and magnesium are the major hardness constituents and primary sources of scale in boilers. The major source of scale is shore water. Scale deposits act as insulators and reduce heat transfer across a surface. Deposits on the boiler tubes will cause the temperature of the metal to increase until overheating, metal softening, blistering, and failure occur.

3. Dissolved oxygen (pitting)-When dissolved oxygen enters the boiler water, it causes localized corrosion and pitting of tube metal.

4. Chloride (pitting corrosion)-Excessive chloride readings indicate seawater contamination. Chloride dissolves the protective layer on boiler metal and pitting corrosion instead of general corrosion results.

The boiler cannot be operated safely and efficiently without careful attention to, and control of, feedwater and boiler water.

**Waste Heat Boiler Treatment.**—The requirements for treating and maintaining WHBs are contained in *Naval Ships' Technical Manual*, chapter 220. To maintain the WHB, you will need to perform the required tests on the boiler water, feedwater, and shore water. The WHBs are treated by two methods, continuous injection and/or the batch feed method. Normally, the preferred method is continuous injection. If this method fails, you can use the batch feed method.

The boilers are treated with trisodium phosphate (TSP) and disodium phosphate (DSP). The TSP provides alkalinity and phosphate. The DSP provides additional phosphate without significantly affecting the alkalinity.

Testing of the WHB for alkalinity, phosphate, and chloride is at the following frequencies:

1. Within 30 minutes after the generator is started
2. Within 1 hour before beginning blowdowns
3. Thirty to 60 minutes after blowdowns
4. As often as required to maintain the limits, but at least every 8 hours (maximum of 8 hours between samples)
5. Thirty to 60 minutes after batch chemical treatment
6. Within 1 1/2 hours before the generator is secured

7. Whenever unusual conditions exist as determined by the EOOW or EDO

If an emergency should arise and it becomes necessary to use shore source feedwater not meeting the requirements for feedwater, sample and test the boiler water hourly. Then treat it accordingly. Hourly testing followed by required treatment must continue until the distilling plants are producing the required quality water and the distillate can be used as makeup.

**Handling and Safety of Treatment Chemicals.**—When handling the TSP or caustic soda, you must wear a face shield, rubber gloves, and a rubber apron. Concentrated solutions of these chemicals are corrosive and will cause burns to the skin, eyes, and body tissue. If you get TSP, caustic soda, or their solutions anywhere on your body, flush the area with cold water. Obtain immediate medical attention if it enters your eyes.

Ensure the safety dispensing bottle is marked and used for boiler-water treatment chemicals only. The safety dispensing bottle is made from linear polyethylene, which has a maximum use temperature of 176°F. As the TSP and DSP dissolve, they generate heat. Water temperature will increase slightly. Do not use hot water to dissolve the chemicals. This may cause the safety dispensing bottle to exceed its temperature use limits.

You can add TSP to water or vice versa without difficulty. You should always add DSP to water because DSP tends to cake if water is poured over it.

### Physical Security Program

Physical security involves the security of the engineering plant to ensure unauthorized entry into unoccupied space and unauthorized tampering with engineering equipment does not occur. Basically, physical security entails the installation and use of security devices (locks and locking pins) to prevent unauthorized personnel from altering the configuration of the engineering plant. This could include preventing engineering personnel from using fluids without reporting their use. It could also prevent anyone from sabotaging the plant. Specific instructions on the management of the physical security program are contained in the *EDORM*.

The physical security program should be designed with common sense and accountability in mind. If something is to be locked, the keys

should only be issued to persons who have a need to use them. A program that gives everyone access to everything is ineffective. Some method must be maintained to allow duty section personnel access to keys, when necessary. Methods for this include watch key rings, duty engineer keys, and an engineering key locker.

The reduction gear covers are also included in physical security. The keys for these high-security locks are held by the chief engineer. Since no opening of a reduction gear is allowed without his approval, he should be the only person allowed to have these keys. For more information on reduction gear security, refer to the *Naval Ships' Technical Manual*, Chapter 241, "Propulsion Reduction Gears, Couplings, and Associated Components."

### **Environmental Quality**

All Navy personnel are responsible for finding ways to reduce pollution of our land, air, and water. You can do your part by strictly complying with U.S. Navy regulations and instructions. For more detailed information concerning pollution abatement, refer to the *Environmental and Natural Resources Manual*, OPNAVINST 5090.1.

### **Gauge Calibration**

Calibration of shipboard gauges and meters is essential to ensure proper operation of complex engineering equipment. Calibration is normally done by specially trained personnel. Most of this calibration is scheduled under 3-M Systems scheduling. Use standard 3-M forms to request outside assistance from the readiness support group (RSG) in your homeport for this calibration. For detailed information on the gauge calibration program, refer to the *Naval Ships' Technical Manual*, Chapter 491, "Electrical Measuring and Testing Equipment," and Chapter 504, "Pressure, Temperature, and Other Mechanical and Electromechanical Measuring Instruments."

### **Valve Maintenance**

Each ship in the Navy depends on the integrity of its valves to prevent flooding, to correctly secure systems, and to ensure proper management of liquid systems. Since a ship has numerous piping systems with many valves, a method to ensure proper valve maintenance is needed. The 3-M Systems includes maintenance on

many valves, but it does not have complete shipwide system valve coverage. A sound valve maintenance program can ensure proper maintenance of all shipboard valves.

When starting an effective valve maintenance, personnel must verify all valves in a piping system. To accomplish this, they must use a variety of resources. These include EOSS drawings, ship's prints, and damage control plates. After a list is developed, you will be responsible for checking it against the actual ship's piping to determine the condition of each valve and ensure each valve is actually in place. Maintenance workers assigned to this task should not change the status of any valve. This is to ensure that they do not inadvertently change the status of the engineering plant. Periodic valve maintenance ensures that valves are packed properly, lubricated, painted correctly (for example, no paint on threads or stem), have the correct type and color coding of handwheel installed, and have identification tags installed. Check all valves with locking devices to ensure the locks are in place, adequate, and intact.

Supervisors of the valve maintenance program generate and maintain local forms to keep a record of valve maintenance. Most of the maintenance can be scheduled during underway periods; however, you should ensure that proper tag-out procedures are followed. For additional information on valve maintenance, refer to OPNAVINST 3540.5.2.

## **PERSONNEL QUALIFICATION STANDARDS**

The PQS documents describe the knowledge and skills a trainee must have to perform certain duties. They speed up the learning progress since each person knows exactly what information to obtain to prepare for qualifying in increasingly complex duties. They individualize learning so each person may take advantage of opportunities to learn on the job. They place the responsibilities for learning on the trainee and encourage self-achievement. They offer a means for the supervisor to check individual speed and performance by providing a convenient record of accomplishment.

Since the PQS have been assembled by groups of experienced officers and petty officers, they attempt to represent the guidance that would be furnished if each person had an individual instructor throughout each step.

Every PQS is designed to support advancement in rating requirements as stated in the



*Navy Enlisted Manpower and Personnel Classifications and Occupational Standards, NAVPERS 18068-E.*

Every PQS document contains the following sections:

1. Introduction
2. Glossary of Qualification Standard Terms
3. Table of Contents
4. 100 series-Fundamentals
5. 200 series-Systems
6. 300 series-Watch Standing
  
7. Bibliography
8. Feedback Forms

## **MAIN SPACE FIRE DOCTRINE**

The Main Space Fire Doctrine is a ship-generated instruction that promulgates policy, implements procedures, and assigns responsibilities for action in the combatting of main space fires. According to this instruction, main space fires can be combatted with installed Halon 1301 systems, installed aqueous film-forming foam (AFFF), portable fire-fighting equipment, EOSS, underway and in-port fire parties, and repair parties. The procedures contained in this instruction are to be followed by all personnel for conditions specified, such as in-port cold iron, auxiliary steaming, and under way.

## **ENGINEERING OPERATIONAL SEQUENCING SYSTEM**

The Navy has developed a system known as the EOSS. Essentially, the EOSS is to the operator as the PMS is to the maintainer.

Main propulsion plants in ships of today's modern Navy are becoming more technically complex as each new class of ship is built and joins the fleet. Increased complexity requires increased engineering skills for proper operation. Ships that lack the required experienced personnel have had material casualties. These casualties have jeopardized their operational readiness. Rapid turnover of engineering personnel who man and operate the ships further compounds the problem of developing and maintaining a high level of operator and operating efficiency.

The Navy has been increasingly aware of these problems. Studies have been done to evaluate the methods and procedures presently used in operating complex engineering plants. The results

of these studies have shown that in many instances sound operating techniques were not followed. Some of the circumstances found to be prevailing in engineering plants are as follows:

- The information needed by the watch stander was usually scattered throughout publications that were generally not readily available.

- The bulk of the publications were not systems oriented. Reporting engineering personnel had to learn specific operating procedures from "old hands" presently assigned. Such practices could ultimately lead to misinformation or degradation of the transferred information. These practices were costly and resulted in nonstandard operating procedures, not only between adjoining spaces, but also between watch sections within the same space.

- Posted operating instructions often did not apply to the installed equipment. They were conflicting or incorrect. No procedures were provided for aligning the various systems with other systems.

- The light-off and securing schedules were prepared by each ship and were not standardized between ships. The schedules were written for general, rather than specific, equipment or system values. They did not include alternatives between all the existing modes of operation.

Following these studies, NAVSEA developed the EOSS, which is designed to help eliminate operational problems. The EOSS involves the participation of all personnel from the department head to the watch stander. The EOSS is a set of systematic and detailed written procedures. The EOSS uses charts, instructions, and diagrams developed specifically for the operational and casualty control function of a specific ship's engineering plant.

The EOSS is designed to improve the operational readiness of the ship's engineering plant. It does this by increasing its operational efficiency and providing better engineering plant control. It also reduces operational casualties and extends the equipment life. These objectives are accomplished first by defining the levels of control; second, by operating within the engineering plant; and last, by providing each supervisor and operator with the information needed. This is done by putting these objectives

in words they can understand at their watch station.

The EOSS is composed of three basic parts.

- The *User's Guide*
- The engineering operational procedures (EOP)
- The engineering operational casualty control (EOCC)

### **EOSS User's Guide**

The *User's Guide* is a booklet that explains the EOSS package and how it is used to the ship's best advantage. It contains document samples and explains how they are used. It provides recommendations for training the ship's personnel using the specified procedures.

The EOSS documentation is developed using work-study techniques. All existing methods and procedures for plant operation and casualty control procedures are documented. These include the actual ship procedures as well as those procedures contained in available reference sources.

Each action is subjected to a critical examination to evaluate the adequacy of the present procedures. At the completion of this analytic phase, new procedural steps are developed into an operational sequencing system. Step-by-step, time-sequenced procedures, and configuration diagrams are prepared to show the plant layout in relation to operational components. The final step in the development phase of an EOSS is a validation on board ship. This is done to ensure technical accuracy and adequacy of the prepared sequencing system. All required corrections are made. They are then incorporated into the package before installation aboard ship.

The resulting sequencing system provides the best tailored operating and engineering operational casualty control procedures available pertaining to a particular ship's propulsion plant. Each level is provided with the information required to enable the engineering plant to respond to any demands placed upon it.

### **Engineering Operational Procedures**

The operational portion of the EOSS, the EOP, has all the information necessary for the proper operation of a ship's engineering plant. It also has guides for scheduling, controlling, and directing plant evolutions through operational modes. This includes receiving shore services, to various modes of in-port auxiliary plant steaming, to underway steaming.

The EOP documentation is prepared for specifically defined operational stages. These are defined as stages I, II, and III.

Stage I deals with the total engineering plant under the direct responsibility of the plant supervisor (EOOW). The EOOW coordinates the placing in operation and securing of all systems and components normally controlled by the various space supervisors. This person also supervises those functions that affect conditions internal to the engineering plant, such as jacking, testing, and spinning main engines. The EOP documentation assists the plant supervisor to ensure optimum plant operating efficiency, proper sequencing of events in each operational evolution, and the training of newly assigned personnel. During a plant evolution, the EOOW designates control and operation of the following systems and components:

- Systems that interconnect one or more engineering plant machinery spaces and electrical systems.
- Major components, such as main engines, and electrical generators.
- Systems and components required to support the engineering plant or other ship functions, such as distilling plants, air compressors, fire pumps, and auxiliaries. These may be placed in operation or secured in response to demand upon their services.

To assist the plant supervisor with these operations, the EOP section provides the following documents:

- Index pages listing each document in the stage I station by identification number and title.



- A diagram for shore services connection locations. This diagram delineates the location of shore service connections for steam, electrical power, feedwater, potable water, firemain, and fuel oil.

- Training diagrams (fig. 2-13) delineating each major piping system to aid in plant familiarization and training of newly assigned personnel. These diagrams indicate the relative locations of lines, valves, and equipment.

Stage II deals with the system component level under supervision of the space supervisor in each engine room (ER) and auxiliary machinery room (AMR), and the electric plant control console (EPCC) operator (EPCC watch). In stage II, the space supervisor accomplishes the tasks delegated by the plant supervisor. The EOP documentation assists the space supervisor in properly sequencing events, controlling the operation of equipment, maintaining an up-to-date status of the operational condition of the equipment assigned, and

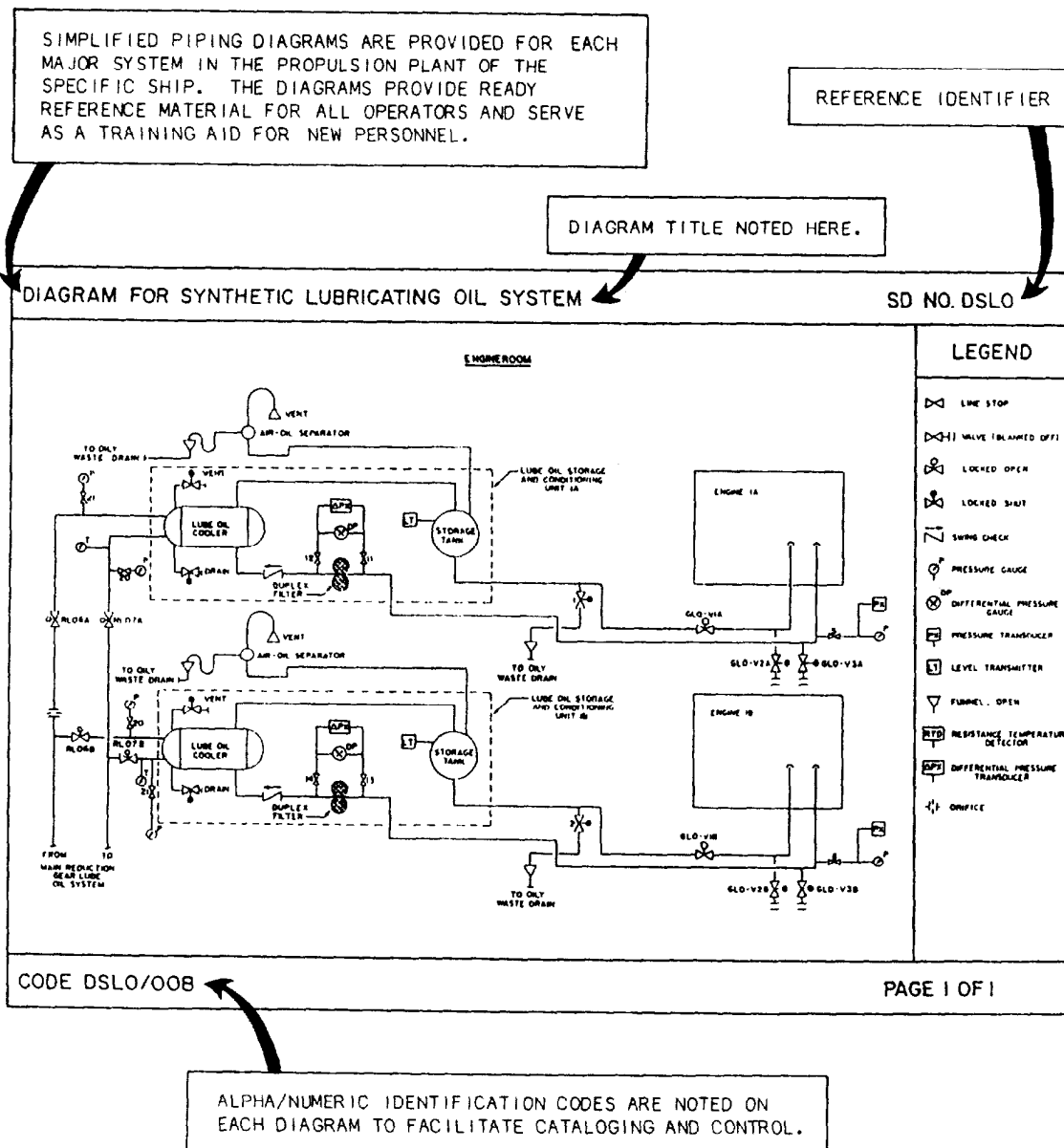

training newly assigned personnel. To assist the space supervisor in the effort, the EOP section provides the following stage II documents:

- Index pages listing each document by identification number and title for each specified operating group, such as ER, AMR, or electrical system.
- Space procedure charts (similar to the plant procedure chart) providing the step-by-step procedures to be accomplished within a space to satisfy and support the requirements of the plant procedure charts.
- Space status board providing a schematic of major systems and a tabular listing of the major equipment within the individual machinery spaces for maintaining a plot of system alignments and equipment operating status. This board is similar in configuration to the casualty control board for the stage I documentation shown in figure 2-14.
- Diagram for electrical plant status delineating generators, switchboards, and shorepower connections within the electrical distribution systems. This diagram is provided in

both the electrical operating group and in the stage I (EOOW) documentation for maintaining a plot of the system alignment.

- Diagram for plant steaming conditions versus optimum generator combinations provided in the electrical operating group documentation. This specifies the preferred electric power generator combination. This diagram is the same as that provided in the stage I documentation.
- Training diagrams of each major piping system developed for stage I, plus diagrams of such systems as the fuel-oil service system and the main engine lube oil system that are normally located within the machinery spaces.

Stage III deals with the system component level under the supervision of component operators. The component operators place equipment in and out of operation, align systems, and monitor and control their operation. This is done by manipulating required valves, switches, and controls. Stage III documents include the following:

- Index pages listing each document by identification number and title for each specified

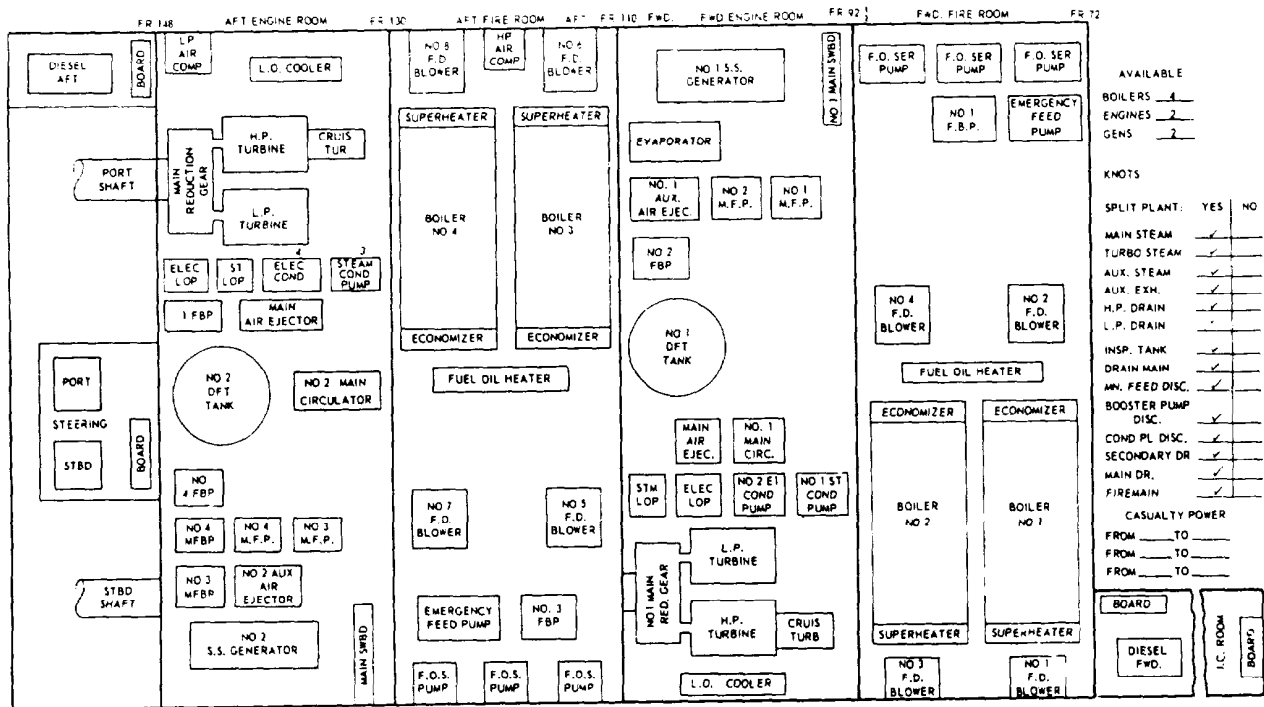

Figure 2-14.—Casualty control board.

system, such as the fuel-oil service system and the lube oil service system.

- Component procedure cards providing step-by-step procedures for systems' alignment or component operation.

- Component procedure cards as required to support each operation or alignment.

- Alignment diagrams (fig. 2-15) amplifying the written procedure to assist the component operator in proper systems' alignment. Alignment

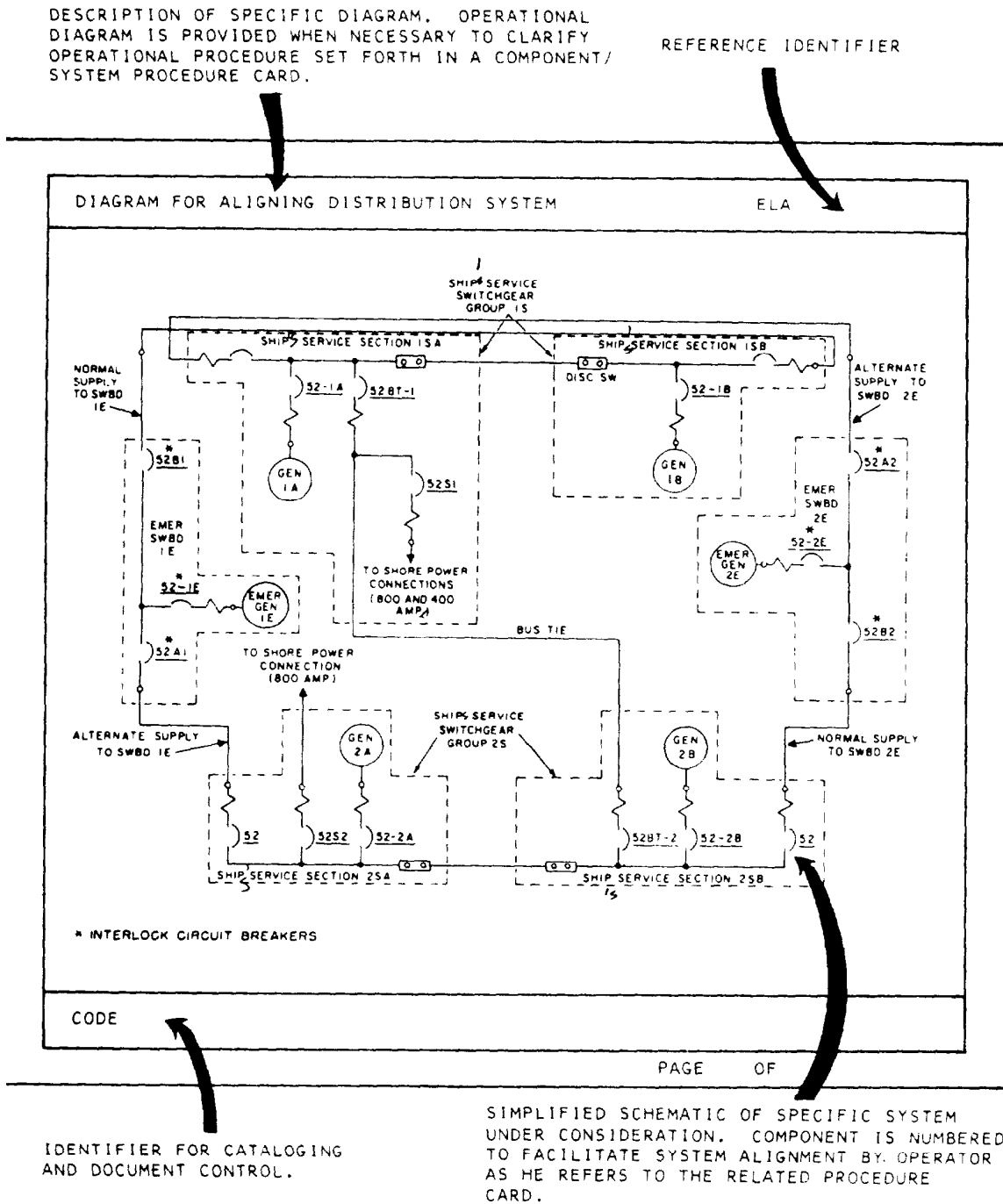

Figure 2-15.—Sample component/system alignment diagram.

diagrams are provided whenever two or more alignment conditions exist for a given system or component.

The operational use of EOP documentation is of primary importance at all levels in controlling, supervising, and operating the engineering plant.

### **Engineering Operational Casualty Control**

The engineering operational casualty control (EOCC) is the casualty control portion of the EOSS. It contains information relevant to the recognition of casualty symptoms and their probable causes and effects. Also, it has information on actions taken to prevent a casualty. It specifies procedures for controlling single- and multiple-source casualties.

Casualty prevention must be the concern of everyone on board. Proper training of all personnel must provide an adequate knowledge and experience in effective casualty prevention. The EOCC manual has efficient, technically correct casualty control and prevention procedures. These procedures relate to all phases of an engineering plant. The EOCC documents possible casualties that may be caused by human error, material failure, or battle. The EOCC manual describes proven methods for the control of a casualty. It also provides information for prevention of further damage to the component, the system, or the engineering plant.

The EOCC manuals (books) are available at each watch station for self-indoctrination. The manuals contain documentation to assist engineering personnel in developing and maintaining maximum proficiency in controlling casualties to the ship's propulsion plant.

Proficiency in EOCC procedures is maintained through a well-administered training program. Primary training concentrates on the control of single-source casualties. These are casualties that may be attributed to the failure or malfunction of a single component or the failure of piping at a specific point in a system. Advanced training concentrates on the control of multiple casualties or on conducting a battle problem. An effective, well-administered watch-stander training program

will contain, as a minimum, the following elements:

- Recognition of the symptoms
- Probable causes
- Probable effects

Preventive actions that may be taken to reduce, eliminate, or control casualties

An EOSS package is not intended to be forgotten once it is developed and installed aboard a ship. It offers many advantages to the ship's operational readiness capabilities and provides detailed step-by-step sequencing of events for all phases of the engineering plant operation. Because it is work studied and system oriented, the EOSS provides the basic information for the optimum use of equipment and systems. It does this by specifying correct procedures tailored for a specific plant configuration.

The EOSS is not intended to eliminate the need for skilled plant operators. No program or system can achieve such a goal. The EOSS is a tool for better use of manpower and skills available. Although the EOSS is an excellent tool for shipboard training of personnel, it is primarily a working system for scheduling, controlling, and directing plant operations and casualty control procedures.

### **SUMMARY**

The information you studied in this chapter has provided you with a general knowledge of the publications, maintenance records, logs, and programs that you will use in your day-to-day routine aboard ship. We have strived to present an overview of a majority of the administrative functions of a GSE3 or GSM3. All of these areas are important in their own right. Some of the subjects will be discussed in greater detail in later chapters. In this chapter we referred you to other publications that will give you a more in-depth explanation of the material covered. You should study them to become a more proficient and reliable technician.

## CHAPTER 3

# TOOLS AND TEST EQUIPMENT

As a third class GSE or GSM, you will be working with different types of hand tools and testing equipment. Your responsibilities include the routine maintenance of the equipment in your engineering spaces. After reading this chapter, you should be able to describe some of the devices you may use during your maintenance procedures. The devices discussed in this chapter are not all the tools and equipment that a GS3 might use. For further information, refer to *Use and Care of Hand Tools and Measuring Tools*, NAVEDTRA 12085, and the Navy Electricity and Electronics Training Series (NEETS), modules 1, 3, and 16. To determine the specific device recommended for each procedure, refer to the appropriate manufacturers' technical manuals, the *Naval Ships' Technical Manual*, and/or other information books.

### HAND TOOLS

Everyone has used a hand tool at one time or another for some type of job. The types of hand

tools described in the following sections are some that you might use, but with which you possibly are not familiar.

### WIRE-TWISTER PLIERS

Wire-twister pliers (fig. 3-1) are three-way pliers that hold, twist, and cut. They are designed to reduce the time used in twisting safety wire on nuts and bolts. To operate them, grasp the wire between the two diagonal jaws, and then use your thumb to bring the locking sleeve into place. When you pull on the knob, the twister twirls and makes uniform twists in the wire. You can push back the spiral rod into the twister without unlocking it. Then another pull on the knob will give a tighter twist to the wire. A squeeze on the handle unlocks the twister. Now you can cut the wire to the desired length with the side cutter. Occasionally, lubricate the spiral of the twister.

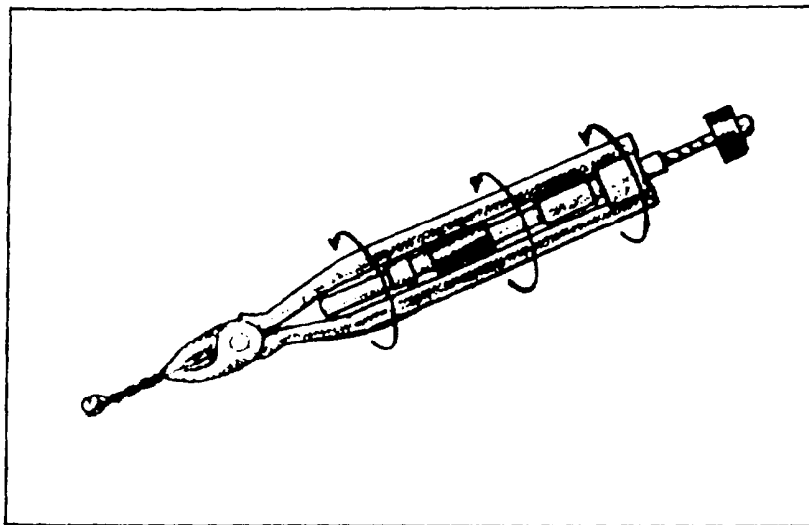
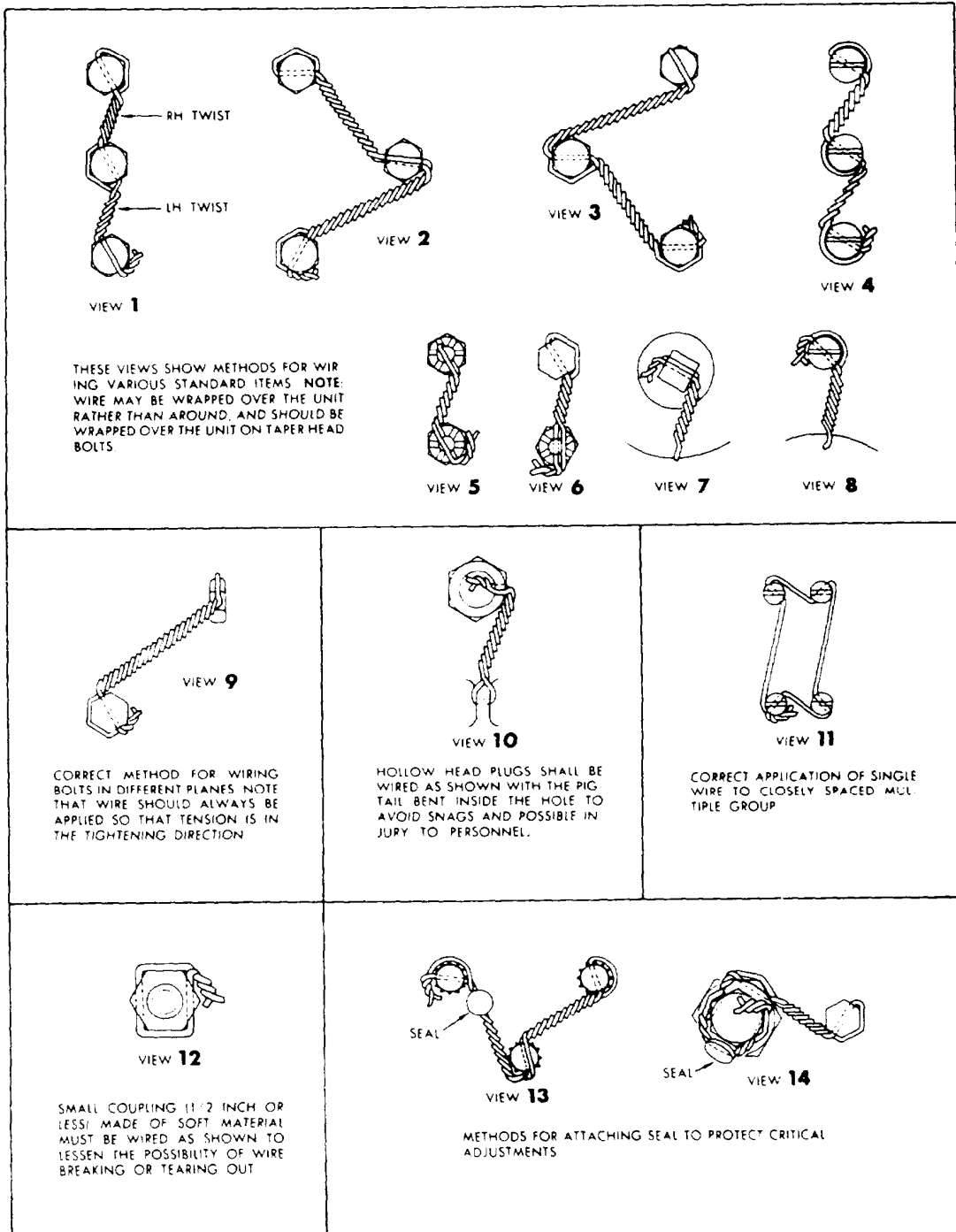

Figure 3-1.—Wire-twister pliers.





293.4

Figure 3-2.—Safety-wiring practices.

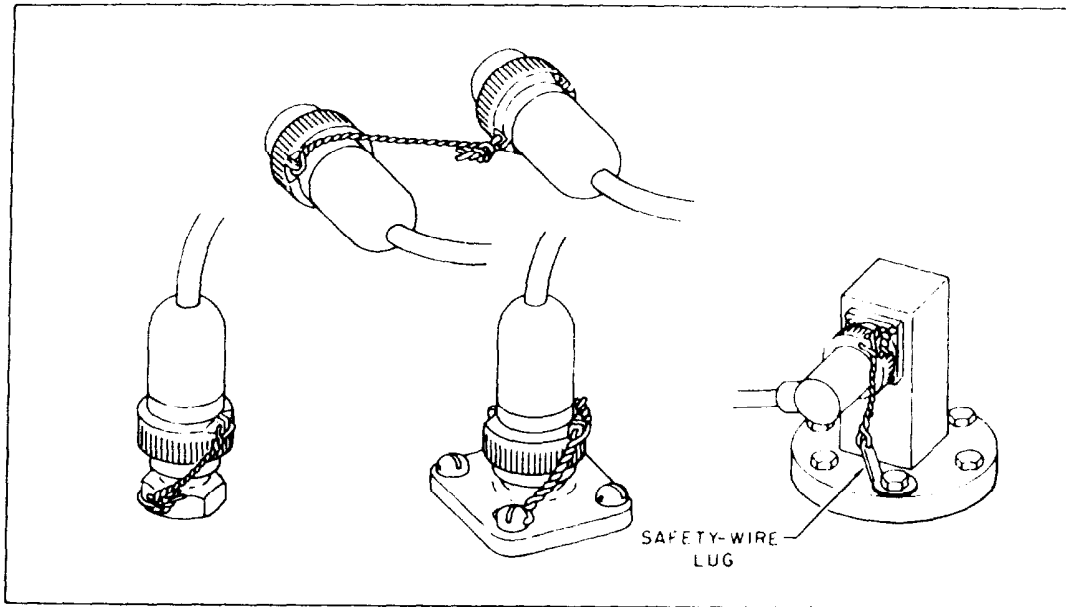

293.5

Figure 3-3.—Safety-wiring electrical connectors.

Figures 3-2 and 3-3 show examples of safety-wiring techniques that you should follow. The figures do not show all possible safety-wiring combinations; however, safety-wiring practices should conform to those shown. Consult specific manufacturers' technical manuals for approved materials and techniques to use in any given application. You will find step-by-step procedures for safety-wiring in *Propulsion Gas Turbine Module LM2500, Trouble Isolation*, volume 2, part 3, S9234-AD-MMO-050/LM2500, section 8.1.

## WRENCHES

While performing your maintenance procedures, you will use a variety of wrenches. This section is about the recommended wrenches you need to be familiar with while working on the gas turbine engine (GTE). You will also learn about wrenches and hand tools that are not recommended for use on the GTE.

### Recommended Wrenches

The only hand tools you should use on GTEs are chrome-plated, nickel-plated, or unplated hand tools. The CROWFOOT wrench (fig. 3-4, view A) is a very handy tool to use for

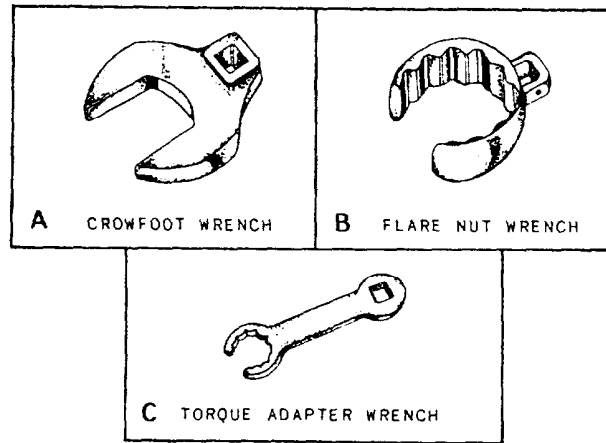

Figure 3-4.—Crowfoot, flare nut, and torque adapter wrenches.

maintenance procedures. You can use it to gain accessibility to hard to reach areas where other wrenches are difficult to use. The head of the wrench is designed like an open-end wrench. However, the other end is designed to accommodate accessories, such as extensions, breaker bars, and torque wrenches. Crowfoot wrenches come in a wide variety of sizes like those of the open-end type of wrenches.

The FLARE NUT wrench (fig. 3-4, view B) is similar to a box wrench. The difference is a slot cut in the wrench head which allows it to fit over tubing or wiring and then onto the fastener. There are two types of this wrench you might use on your ship. The first type is long handled, similar to the regular box wrench, with a different size on each end. The second type is short. The other end is designed to accommodate accessories, such as extensions, breaker bars, and torque wrenches. These flare nut wrenches are made with 6, 8, 12, and 16 points or notches. The wrenches on your ship will generally be 12 points because of the numerous 12-point fasteners used on the GTE. You can also use the 12-point wrench effectively on 6-point (hex head) fasteners. As with the crowfoot wrenches, the flare nut wrenches come in a wide variety of sizes.

The TORQUE ADAPTER wrench (fig. 3-4, view C) is similar to a box wrench. The other end is designed to accommodate accessories, such as extensions, breaker bars, and torque wrenches. They are used to reach nuts and bolts that are in hard to reach locations.

### Nonrecommended Wrenches and Hand Tools

The adjustable wrench and cadmium-plated or silver-plated tools are NOT recommended for

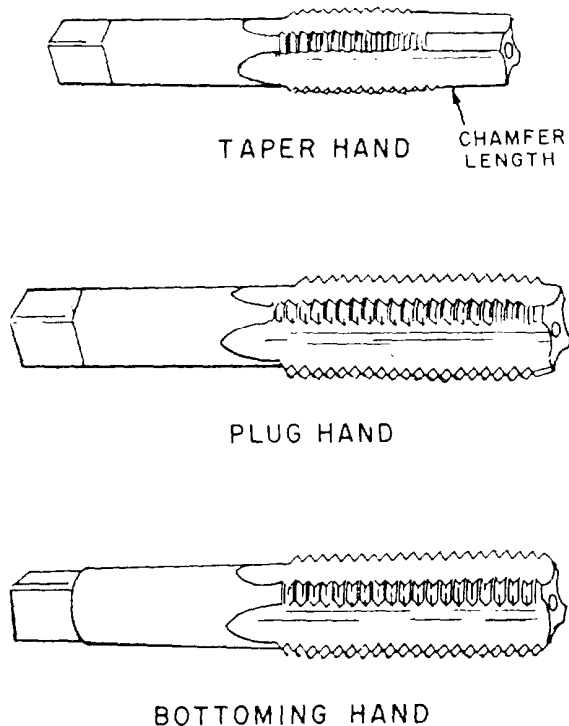

Figure 3.5.—Types of common taps.

you to use while working on GTEs. You might, however, use them elsewhere for maintenance.

The ADJUSTABLE wrench is useful because it will fit nuts and bolts that are odd-sized or slightly damaged or burred. BUT, good engineering practice dictates that you use the proper size wrench for the work you are doing. Parts on the GTEs are made of high-quality materials and are standard sizes. Because of the design of the adjustable wrench, it could cause extensive damage to the GTE. If it slips, gouging and/or scratching could occur. Do not use a part if it is damaged in any way.

DO NOT use CADMIUM-PLATED or SILVER-PLATED hand tools when working on titanium parts of GTEs. If you use these hand tools, you could cause particles of cadmium or silver to become imbedded in the titanium parts. At temperatures above 600°F, the cadmium or silver can cause embrittlement. This results in overstressed areas and possible cracking. To prevent this, use chrome-plated, nickel-plated, or unplated hand tools on titanium parts.

### TAPS AND DIES

Taps and dies are used to cut threads in metal, plastics, or hard rubber. The taps are used for cutting internal threads, and the dies are used to cut external threads. Many different types of taps are available. However, the most common are the taper, plug, and bottoming (fig. 3-5).

The taper (starting) hand tap has a chamfer length of 8 to 10 threads. You would use these taps when starting a tapping operation and when tapping through holes.

Plug hand taps have a chamfer length of 3 to 5 threads and are designed for use after the taper tap.

Bottoming hand taps are used for threading the bottom of a blind hole. They have a very short chamfer length of only 1 to 1 1/2 threads. This



Figure 3-6.—Rethreading die.

tap is always used after the plug tap has been used. Both the taper and plug taps should precede the use of the bottoming hand tap.

Dies are available in several different shapes and are of the solid or adjustable type. Figure 3-6 shows a solid type of rethreading die. It is used mainly for dressing over bruised or rusty threads on screws or bolts. It is available in a variety of sizes for rethreading American standard coarse and fine threads. These dies are usually hexagon in shape and can be turned with a socket, box, open-end, or any wrench that will fit.

Round split adjustable dies (fig. 3-7) are called "button" dies. You can use them in either hand diestocks or machine holders. The adjustment in

the screw adjusting type is made by a fine-pitch screw which forces the sides of the die apart or allows them to spring together. The adjustment in the open adjusting type is made by three screws in the holder, one for expanding and two for compressing the dies. Round split adjustable dies are available in a variety of sizes to cut American standard coarse and fine threads, special form threads, and the standard sizes of threads that are used in Britain and other European countries. For hand threading, these taps and dies are held in tap wrenches and diestocks (fig. 3-8).

### THREAD CHASERS

Thread chasers are threading tools that have several teeth. They are used to rethread (chase)

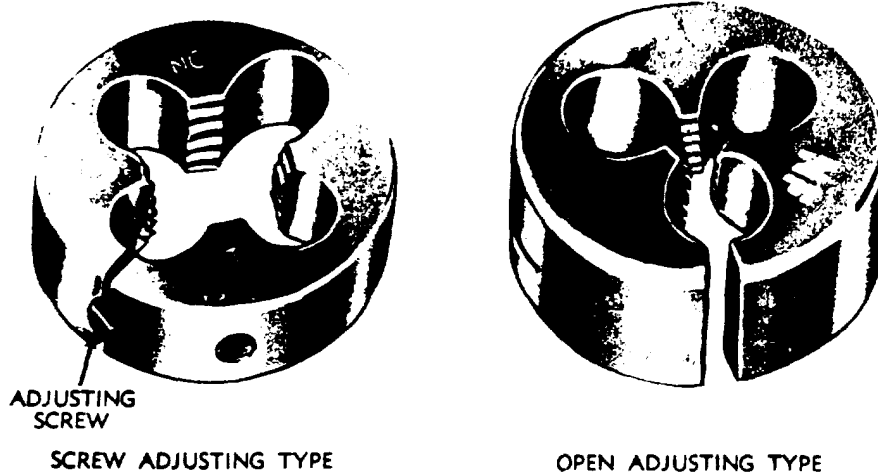

Figure 3-7.—Types of adjustable dies.

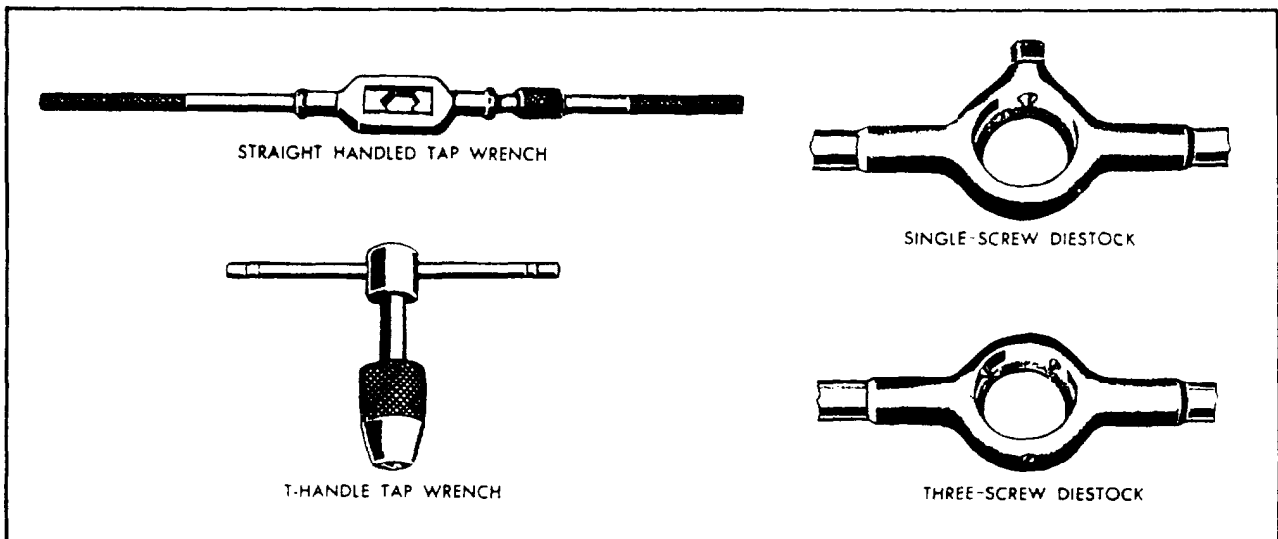

Figure 3-8.—Tap wrenches and diestocks.

damaged external or internal threads (fig. 3-9). These tools are available to chase standard threads. The internal thread chaser has its cutting teeth located on a side face. The external thread chaser has its cutting teeth on the end of the shaft. The handle end of the tool shaft tapers to a point.

### SCREW AND TAP EXTRACTORS

Screw extractors are used to remove broken screws without damaging the surrounding material or the threaded hole. Tap extractors are used to remove broken taps.

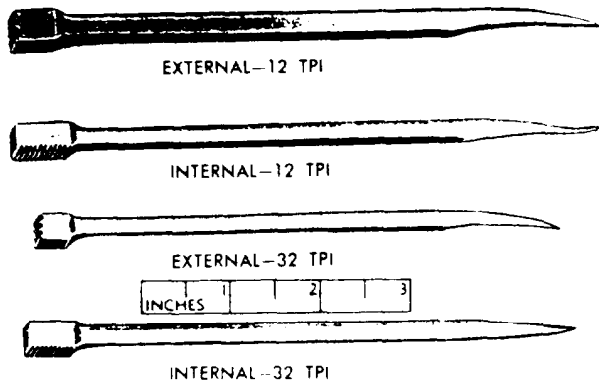

Figure 3-9.—Thread chasers.

Tap extractors are straight and have prongs from end to end (fig. 3-10, view A). These extractors are available to remove broken taps ranging from 1/4 inch to 1 inch in outside diameter. Spiral tapered extractors (fig. 3-10, view B) are sized to remove screws and bolts ranging from 3/16 inch to 3 1/2 inches in outside diameter.

Most sets of extractors include twist drills and a drill guide. Tap extractors are similar to the screw extractors and are sized to remove taps ranging from 3/16 to 3 1/2 inches in outside diameter.

### MECHANICAL FINGERS

You can retrieve small articles that have fallen into places where you cannot reach them by hand with the mechanical fingers. You can also use this tool when starting nuts or bolts in difficult areas. The mechanical fingers (fig. 3-11) have a tube containing flat springs that extend from the end of the tube to form clawlike fingers, much like the screw holder. The springs are attached to a rod that extends from the outer end of the tube. A plate is attached to the end of the tube; a similar plate, which you press with your thumb, is attached to the end of the rod. A coil spring placed around the rod between the two plates holds them

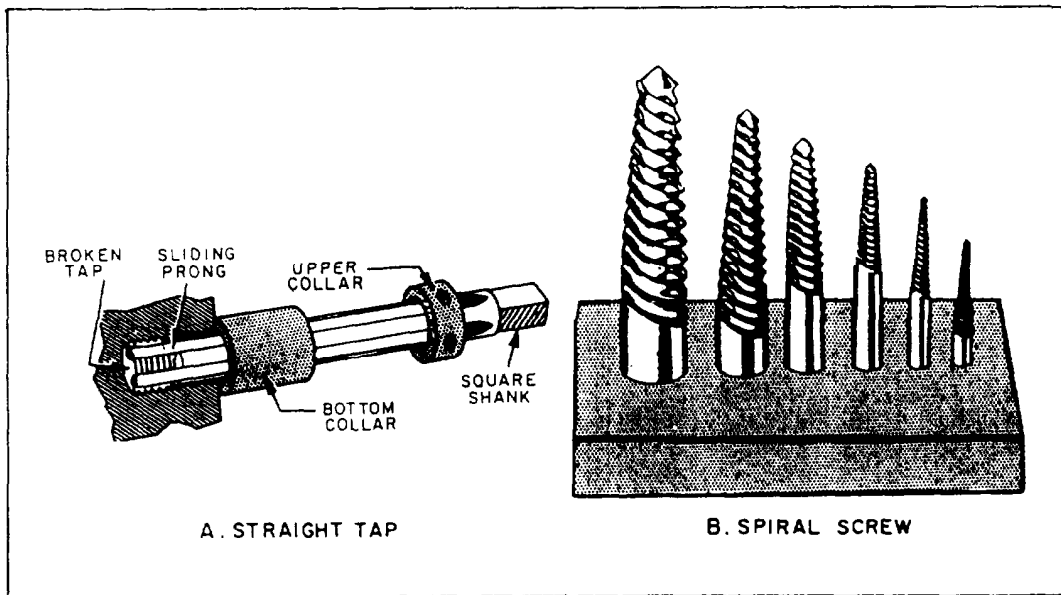

Figure 3-10.—Tap and screw extractors.

apart and retracts the fingers into the tube. With the bottom plate grasped between your fingers and enough thumb pressure applied to the top plate to compress the spring, the tool fingers extend from the tube in a grasping position. When the thumb pressure is released, the tool fingers retract into the tube as far as the object they hold allows. Thus, enough pressure is applied on the object to hold it securely. Some mechanical fingers have a flexible end on the tube to permit their use in close quarters or around obstructions.

**NOTE: Do NOT use mechanical fingers as a substitute for wrenches or pliers. The fingers are made of thin sheet metal or spring wire and you can easily damage them by overloading.**

**INSPECTION MIRROR**

Several types of inspection mirrors are available for use in maintenance. The mirror is issued in a variety of sizes and may be

round or rectangular. The mirror is connected to the end of a rod and may be fixed or adjustable (fig. 3-12).

The inspection mirror will aid you in making detailed inspection where you cannot directly see the inspection area. By angling the mirror, and with the aid of a flashlight, you can inspect most required areas. A late model inspection mirror features a light to aid you in viewing those dark places where the use of a flashlight is not convenient.

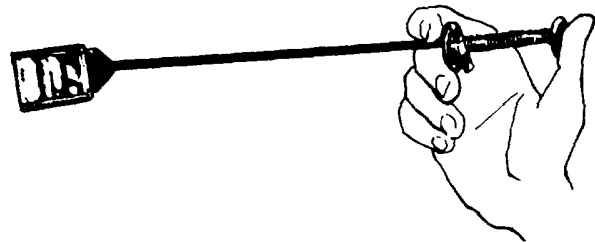

Figure 3-12.—Adjustable inspection mirror.

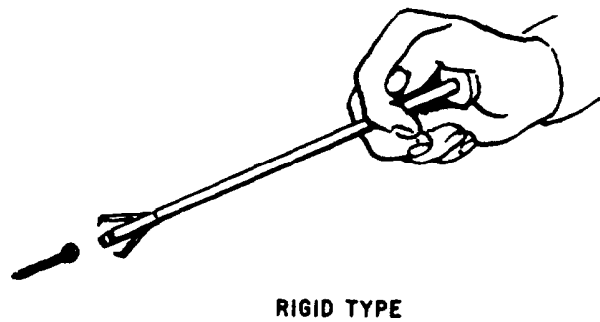
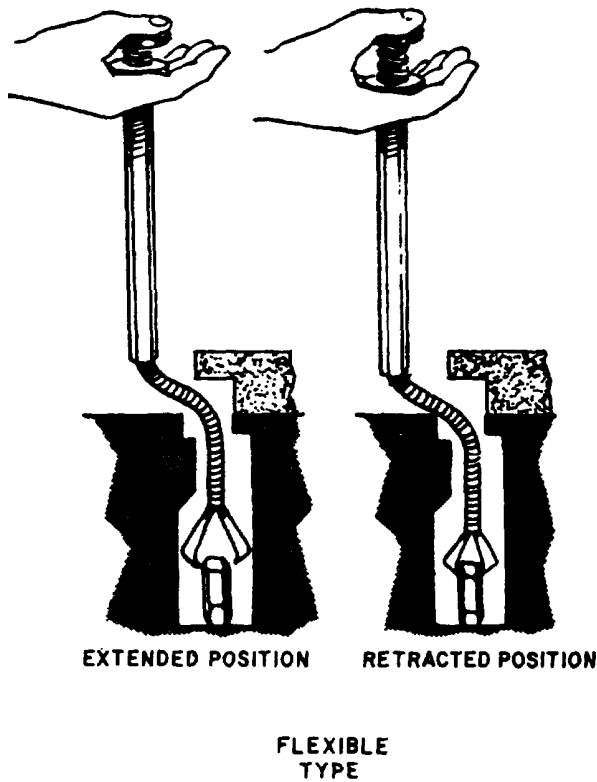

Figure 3-11.—Mechanical fingers.

## WIRE-WRAP HAND TOOLS

Basically, wire wrapping is simply winding a solid wire tightly around a stiff pin to provide a good junction. Figure 3-13 shows some of the types of hand tools currently available for this purpose. Wire-wrap hand tools are used with different sized bits and sleeves, depending on the size of the wire being used. Some ships have wire-wrap kits for the GSs. On other ships you might need to borrow these hand tools from other divisions, such as the Data Systems Technicians or the Fire Control Technicians. The principles and techniques of wire-wrapping will be discussed in chapter 10 of this training manual.

### PRECISION TOOLS

When performing maintenance or repair on various equipment, you are required to

adjust, tighten, or space components to specific tolerances. To do this, you must have an understanding of how to use and read the measuring instruments involved, such as torque wrenches, micrometers, and depth gauges. This section covers some of the measuring instruments you need to become familiar with.

### TORQUE WRENCHES

Torque wrenches are used to tighten nuts, bolts, and fasteners to specific tolerances. Due to the variations in temperatures associated with operating equipment, various parts are placed under stress. If parts are not tightened evenly and in a uniform manner, one or two bolts or fasteners could bear the brunt of the stress. This can result in damaged and broken parts. Proper tightening following the manufacturer's instructions

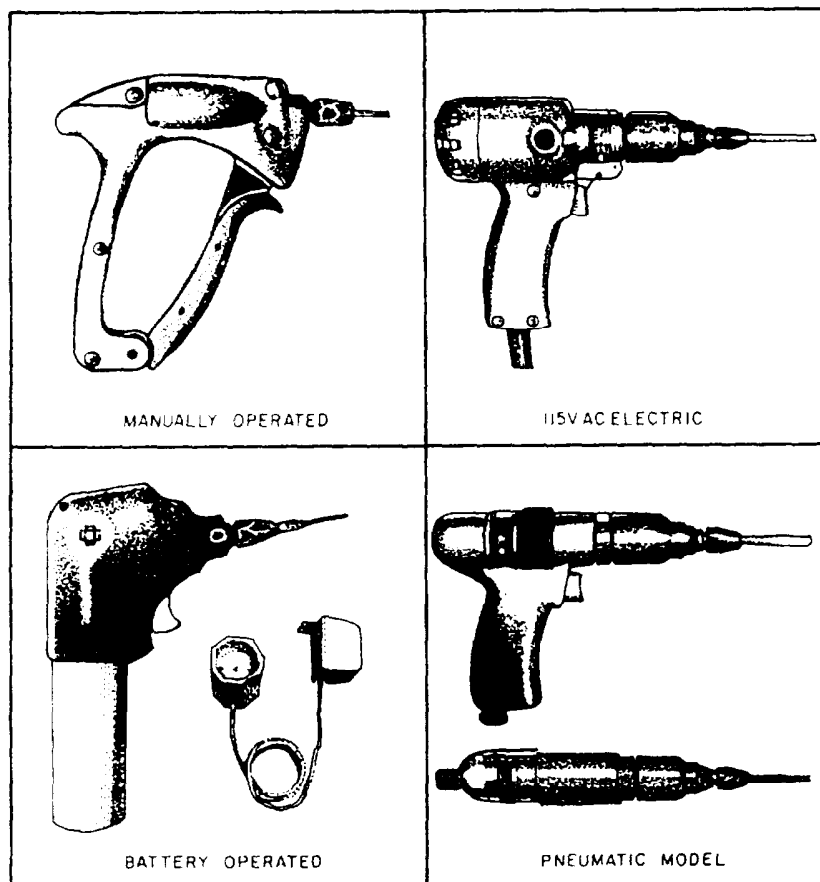

Figure 3-13.—Examples of wire-wrap tools.

and standards will prevent this. Torque wrenches must be kept in calibration. Ensure you use ONLY calibrated torque wrenches.

### Types of Torque Wrenches

The three most commonly used torque wrenches are the deflecting beam, dial indicating, and micrometer setting types (fig. 3-14). When using the deflecting beam and the dial indicating torque wrenches, you read the torque on a dial or scale mounted on the handle of the wrench.

The torque wrench you will probably use is the micrometer setting. This type is easier to use because you do not have to watch a dial or pointer while using the wrench.

To use a micrometer setting wrench, unlock the grip and adjust the handle to the desired setting on the micrometer scale. Then, relock the grip. Install the required socket or adapter to the square drive of the handle. Place the wrench assembly on the nut or bolt and pull in a clockwise direction with a smooth, steady motion. (A fast or jerky motion results in an improperly torqued unit.) When the applied torque reaches the torque value, which is indicated on the handle setting,

a signal mechanism automatically issues an audible click. Next the handle releases, or “breaks,” and moves freely for a short distance. You can easily feel the release and free travel and know when the torquing process is complete.

The procedure for using the deflecting beam and the dial indicating wrenches is the same as the micrometer setting wrench; however, you have to hold the torque at the desired value until the reading is steady.

### Torque Values

Torque values are expressed in pound-inches (lb-in.) or pound-feet (lb-ft). One pound-inch (or 1 pound-foot) is the twisting force of 1 pound applied to a twist fastener (such as a bolt or nut) with 1 inch (or 1 foot) of leverage. This twisting force is applied to the fastener to secure the components. When you are working with or reading torque values, they are usually expressed in inch-pounds (in.-lb) or foot-pounds (ft-lb).

A manufacturer’s or a technical manual generally specifies the amount of torque you should apply to a fastener. To assure getting the correct amount of torque on the fastener, use the wrench according to the manufacturer’s instructions. When using an adapter (such as a crowfoot wrench) with a torque wrench, you must calculate the correct adapter torque.

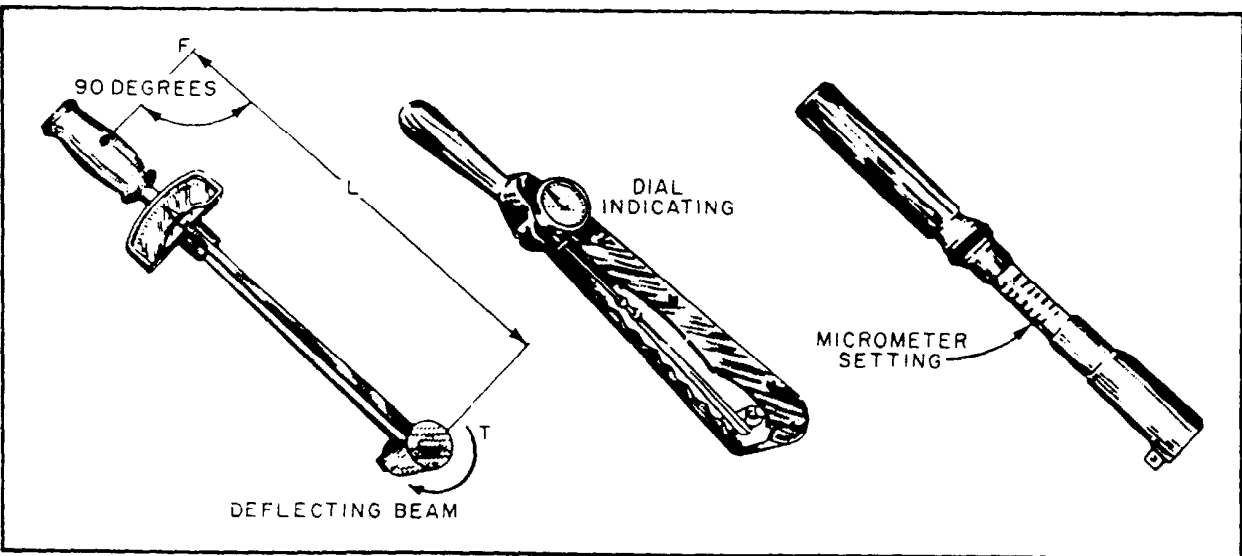

Figure 3-14.—Torque wrenches.



Figure 3-15 shows a step-by-step method to calculate torque.

### Proper Use of Torque Wrenches

Use the torque wrench which will read about midrange for the amount of torque to be applied.

BE SURE THAT THE TORQUE WRENCH HAS A CURRENT CALIBRATION LABEL ON IT BEFORE YOU USE IT. The accuracy of torque-measuring depends a lot on how the threads are cut and on the cleanliness of the threads of the item being torqued. Make sure you inspect and clean the threads. If the manufacturer

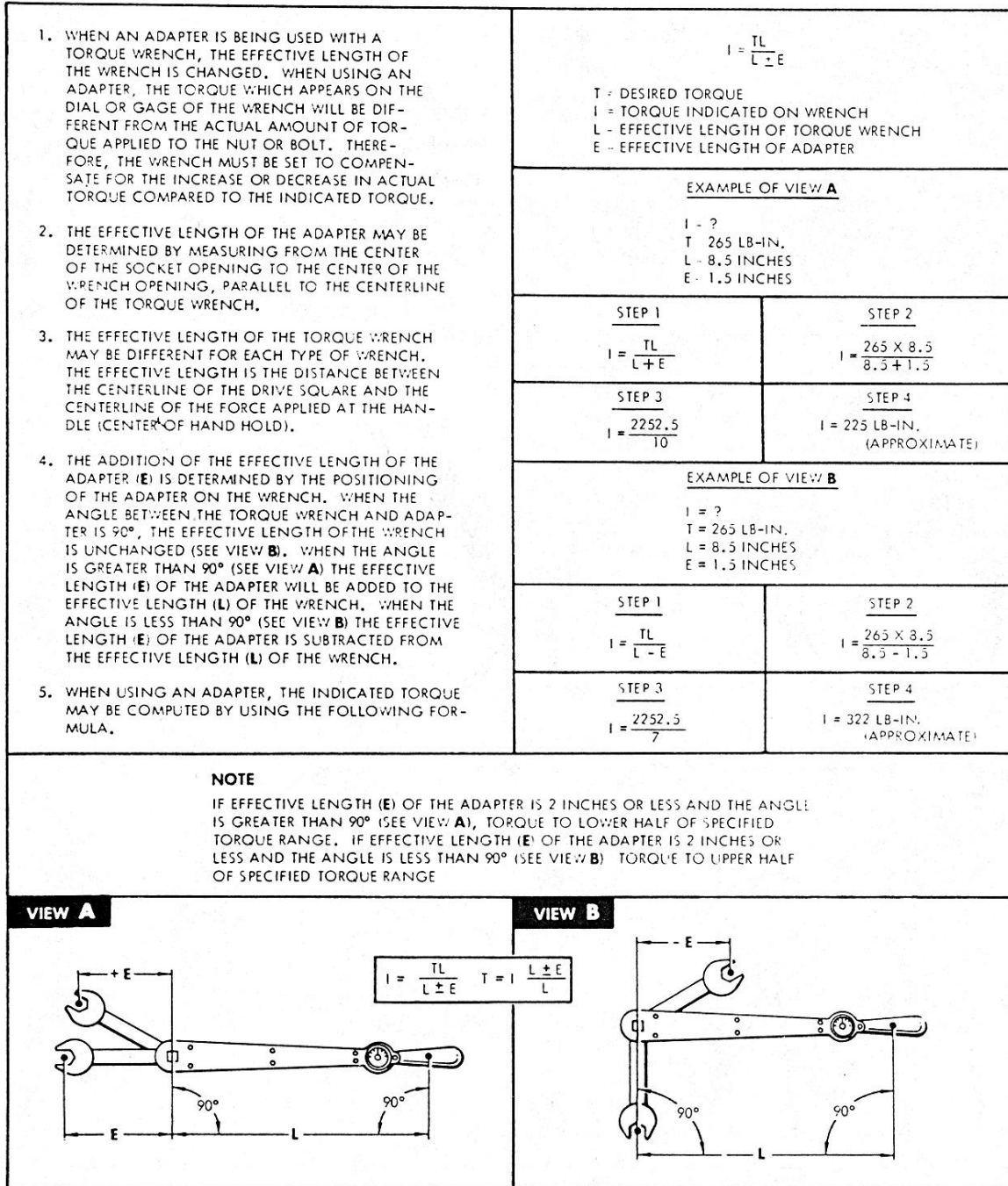

Figure 3-15.—Determining torque wrench correction factors.

specifies a thread lubricant, use it to obtain the most accurate torque reading.

Torque wrenches are delicate and expensive tools. Observe the following precautions when using them :

1. Do not move the setting handle below the lowest torque setting when you use the micrometer setting. However, place it at its lowest setting prior to returning it to storage.

2. Do not use the torque wrench to apply greater amounts of torque than its rated capacity.

3. Do not use the torque wrench to break loose bolts that have been previously tightened.

4. Do not drop the wrench. The resulting jolt can affect its accuracy.

5. Do not apply a torque wrench to a nut that has been tightened. Back off the nut one turn with

a nontorque wrench and retighten to the correct torque with the indicating torque wrench.

6. Do not use a torque wrench before checking its calibration date. Calibration intervals have been established for all torque tools used in the Navy. When a tool is calibrated by a qualified calibration activity at a shipyard, tender, or repair ship, a label showing the next calibration due date is attached to the handle. Check this date before you use a torque tool to ensure that it is not overdue for calibration.

You can find specific information on torque values for equipment in the manufacturer's technical manual.

### SIMPLE CALIPERS

Simple calipers are used in conjunction with a scale to measure diameters. Figure 3-16

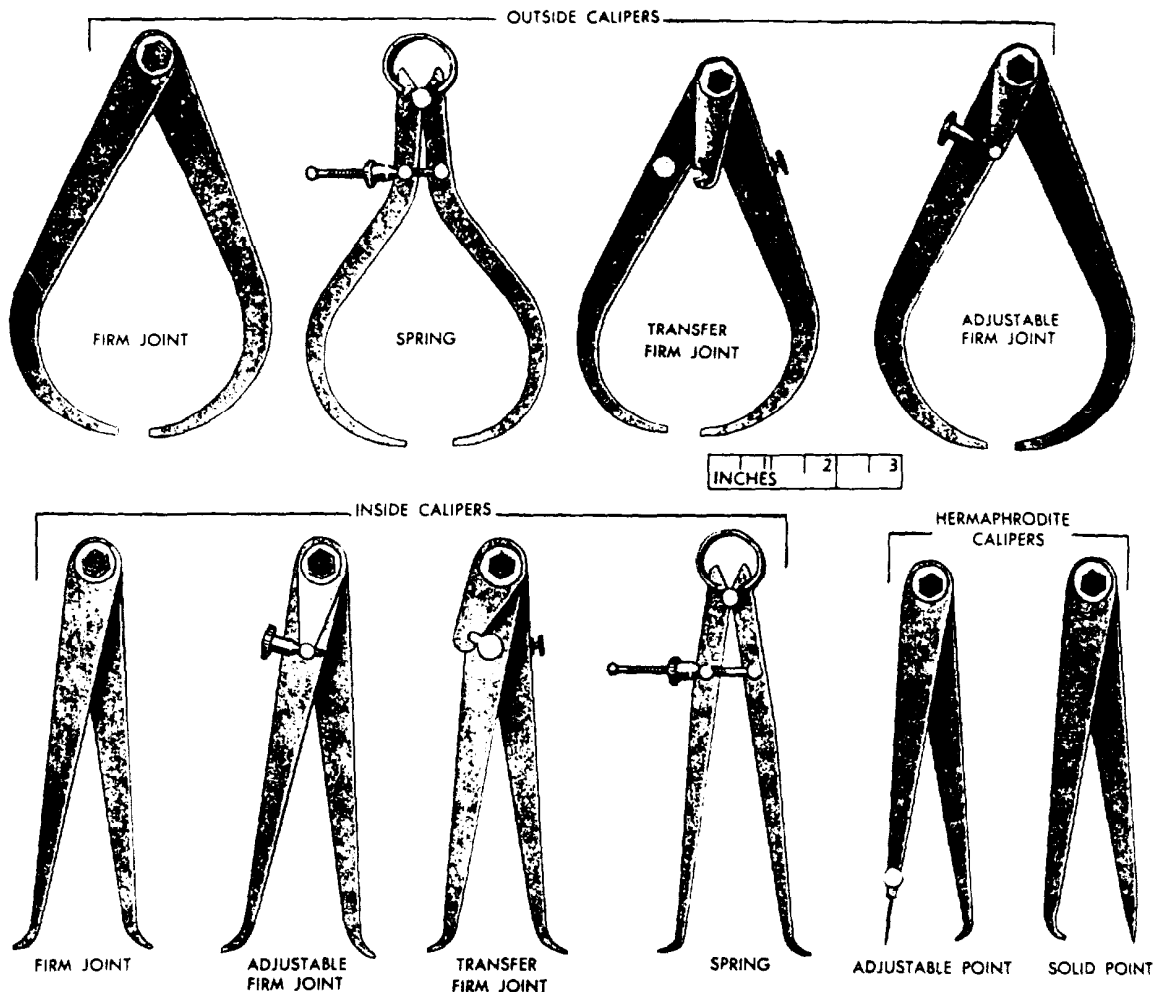

Figure 3-16.—Simple calipers-noncalibrated.

4.17A

shows the calipers most commonly used in the Navy.

Outside calipers for measuring outside diameters are bow-legged; those used for inside diameters have straight legs with the feet turned outward. You adjust calipers by pulling or pushing the legs to open or close them. You can make fine adjustment on calipers by tapping one leg lightly on a hard surface to close them or by turning them upside down and tapping on the joint end to open them.

Spring-joint calipers have the legs joined by a strong spring hinge and linked together by a screw and adjusting nut. For measuring chamfered cavities (grooves), or for use over flanges, transfer calipers are available. They are equipped with a small auxiliary leaf attached to one of the legs by a screw. The measurement is made as with ordinary calipers; then the leaf is locked to the leg. The legs may be opened or closed as needed to clear the obstruction, and then brought back and locked to the leaf again, which restores them to the original setting.

A different type of caliper is the hermaphrodite, sometimes called an odd-leg caliper. This caliper has one straight leg ending in a sharp point, sometimes removable, and one bow leg. The hermaphrodite caliper is used chiefly for locating the center of a shaft or for locating a shoulder.

You can find out more about how to use and to care for simple calipers in

*Use and Care of Hand Tools and Measuring Tools*, NAVEDTRA 12085 chapter 3.

### SLIDE CALIPER

The main disadvantage of using ordinary calipers is that they do not give a direct reading of a caliper setting. As explained earlier, you must measure a caliper setting with a rule. To overcome this disadvantage, use slide calipers (fig. 3-17). This instrument is occasionally called a caliper rule.

Slide calipers can be used for measuring outside, inside, and other dimensions. One side of the caliper is used as a measuring rule, while the scale on the opposite side is used in measuring outside and inside dimensions. Graduations on both scales are in inches and fractions. A locking screw holds the slide caliper jaws in position during use. Stamped on the frame are the words IN and OUT. You use these in reading the scale while making inside and outside measurements, respectively.

### VERNIER CALIPER

A vernier caliper (fig. 3-18) consists of an L-shaped member with a scale engraved on the long shank. A sliding member is free to move on the bar and carries a jaw which matches the arm of the L. The vernier scale is engraved on a small plate that is attached to the sliding member.

Perhaps the most distinct advantage of the vernier caliper, over other types of caliper, is the

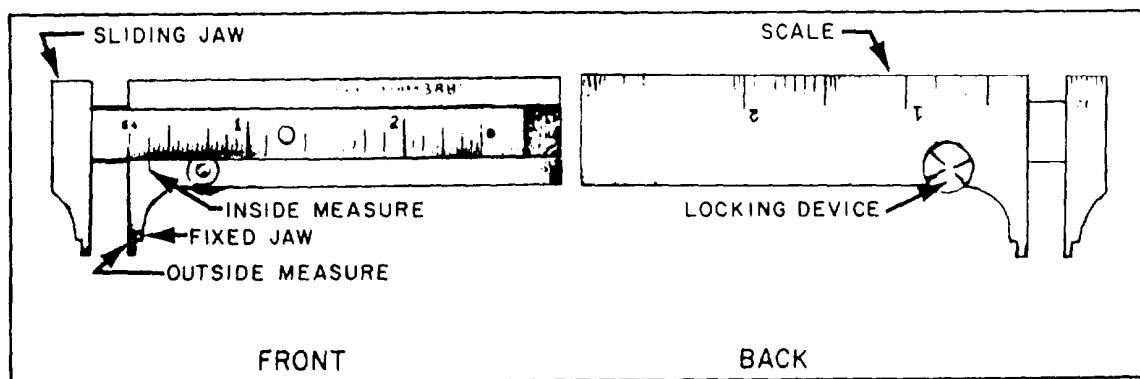

Figure 3-17.—Slide caliper.

ability to provide very accurate measurements over a large range. It can be used for both internal and external surfaces. To use the vernier caliper, you must be able to measure with a slide caliper and read a vernier scale.

## MICROMETER

In much wider use than the vernier caliper is the micrometer caliper, commonly called the "mike." A person who is working with machinery or in a machine shop must thoroughly understand the mechanical principles, construction, use, and care of the micrometer. Figure 3-19 shows an

outside micrometer caliper with the various parts clearly indicated. The most commonly used micrometers are accurate to measure distances to the nearest 1/1,000th of an inch, but if you need to measure to the nearest 1/10,000th of an inch, you can use a vernier micrometer caliper. The measurement is usually expressed or written as a decimal; so you must know the method of writing and reading decimals.

## Types of Micrometers

There are three types of micrometers that are most commonly used throughout the Navy: the outside micrometer caliper (including the screw

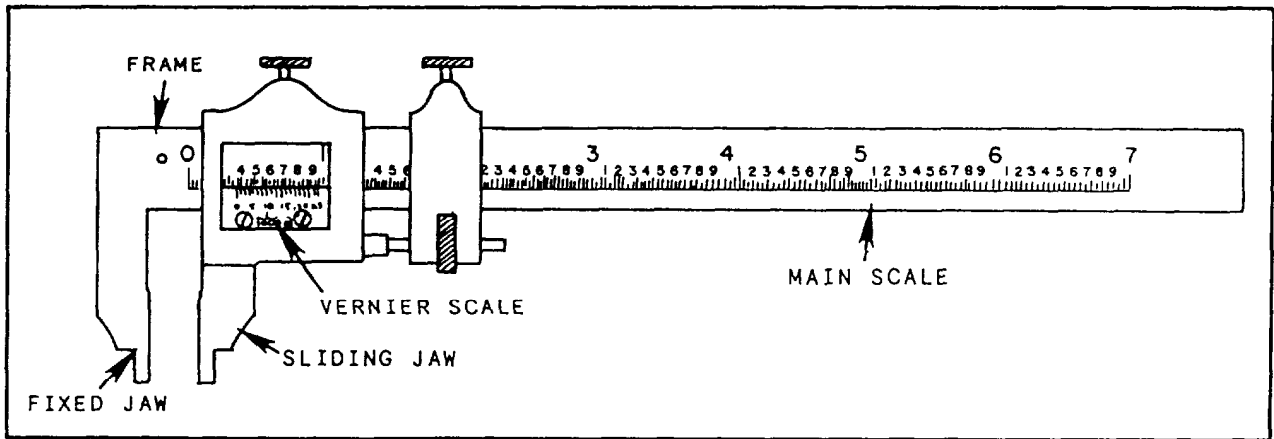

28.4B

Figure 3-18.—Vernier caliper.

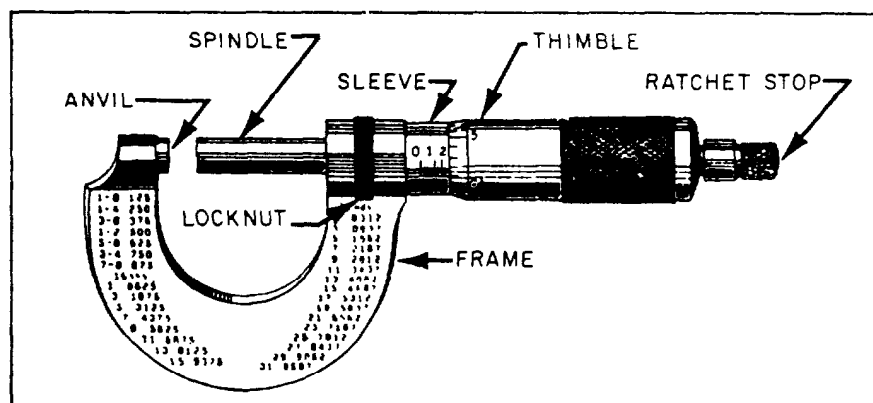

4.20.1A

Figure 3-19.—Nomenclature of an outside micrometer caliper.

thread micrometer), the inside micrometer, and the depth micrometer (fig. 3-20). The outside micrometer is used for measuring outside dimensions, such as the diameter of a piece of round stock. The screw thread micrometer is used to determine the pitch diameter of screws. The inside micrometer is used for measuring inside dimensions. For example, it is used to measure the inside diameter of a tube or hole, the bore of a cylinder, or the width of a recess. The depth micrometer is used for measuring the depth of holes or recesses.

### Selecting the Proper Micrometer

The types of micrometers commonly used are made so that the longest movement possible between the spindle and the anvil is 1 inch. This movement is called the range. The frames of micrometers, however, are available in a wide variety of sizes, from 1 inch up to as large as 24 inches. The range of a 1-inch micrometer is from 0 to 1 inch; in other words, it can be used on work where the part to be measured is 1 inch or less. A 2-inch micrometer has a range from 1 inch to 2 inches, and it measures only work between 1 and 2 inches thick; a 6-inch micrometer has a range from 5 to 6 inches, and it measures

only work between 5 and 6 inches thick. Therefore, in selecting a micrometer, you must first find the approximate size of the work to the nearest inch, and then select a micrometer that fits it. For example, to find the exact diameter of a piece of round stock, use a rule and find the approximate diameter of the stock. If it is 3 1/4 inches, you need a micrometer with a 3- to 4-inch range to measure the exact diameter. Similarly, with inside and depth micrometers, you must fit rods of suitable lengths into the tool to get the approximate dimension within an inch; then, you read the exact measurement by turning the thimble. The size of a micrometer indicates the size of the largest work it measures.

### Reading a Micrometer Caliper

Figure 3-21 shows an enlarged sleeve and thimble scales on the micrometer caliper. To understand these scales, you need to know that the threaded section on the spindle, which revolves, has 40 threads per inch. Therefore, every time the thimble completes a revolution, the spindle advances or recedes 1/40 inch (0.025 inch).

Notice that the horizontal line on the sleeve is divided into 40 equal parts per inch. Every

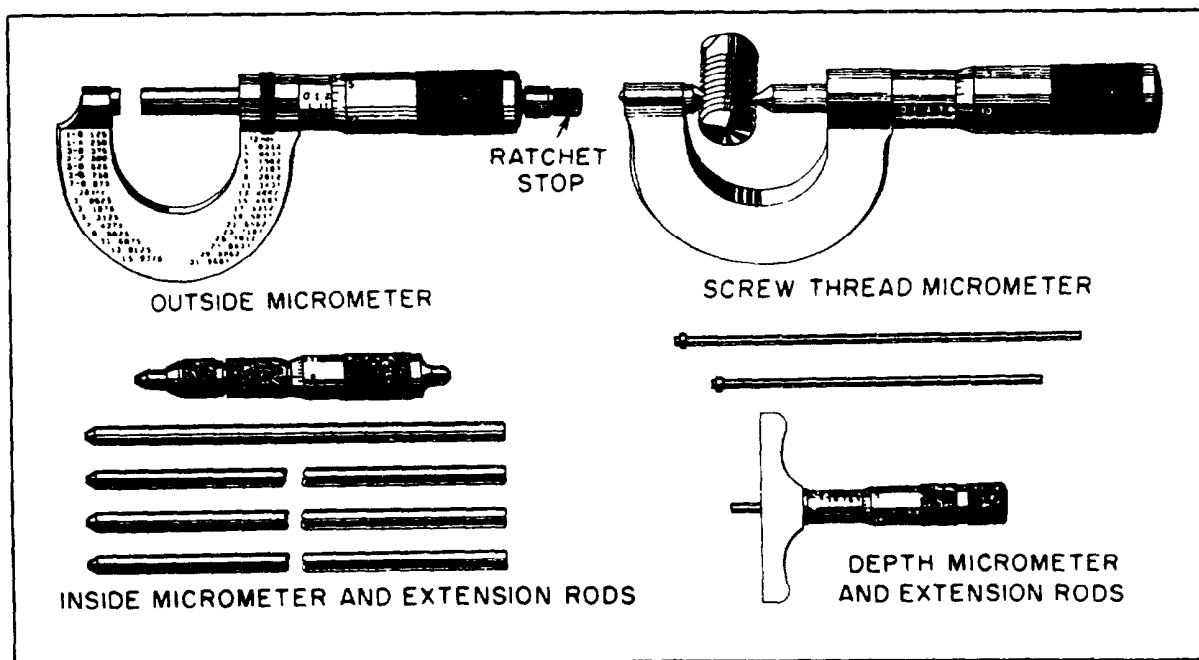

Figure 3-20.—Common types of micrometers.

4.20.1B

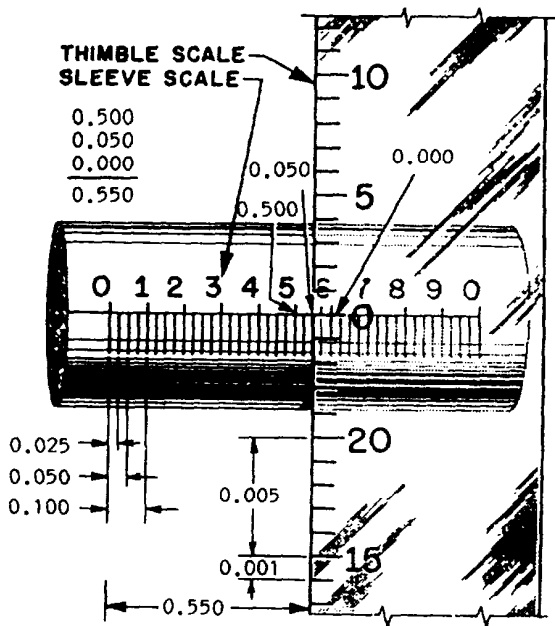

Figure 3-21.—Sleeve and thimble scales of a micrometer (enlarged).

fourth graduation is numbered 1, 2, 3, 4, and so on, representing 0.100 inch, 0.200 inch, and so on. When you turn the thimble so that its edge is over the first sleeve line past the 0 on the thimble scale, the spindle has opened 0.025 inch. If you turn the spindle to the second mark, it has moved 0.025 inch plus 0.025 inch or 0.050 inch. You use the scale on the thimble to complete your reading when the edge of the thimble stops between graduated lines. This scale is divided into 25 equal parts, each part representing 1/25 of a turn; and 1/25 of 0.025 inch is 0.001 inch. As you can see, every fifth line on the thimble scale is marked 5, 10, 15, and so on. The thimble scale, therefore, permits you to take very accurate readings to the thousandths of an inch; since you can estimate between the divisions on the thimble scale, fairly accurate readings to the ten thousandth of an inch are possible.

The closeup in figure 3-22 helps you to understand how to take a complete micrometer reading. Count the units on the thimble scale and add them to the reading on the sleeve scale. The reading in the figure shows a sleeve reading of 0.250 inch (the thimble having stopped slightly more than halfway between 2 and 3 on the sleeve) with the 10th line on the thimble scale coinciding with the horizontal sleeve line. Number 10 on this scale

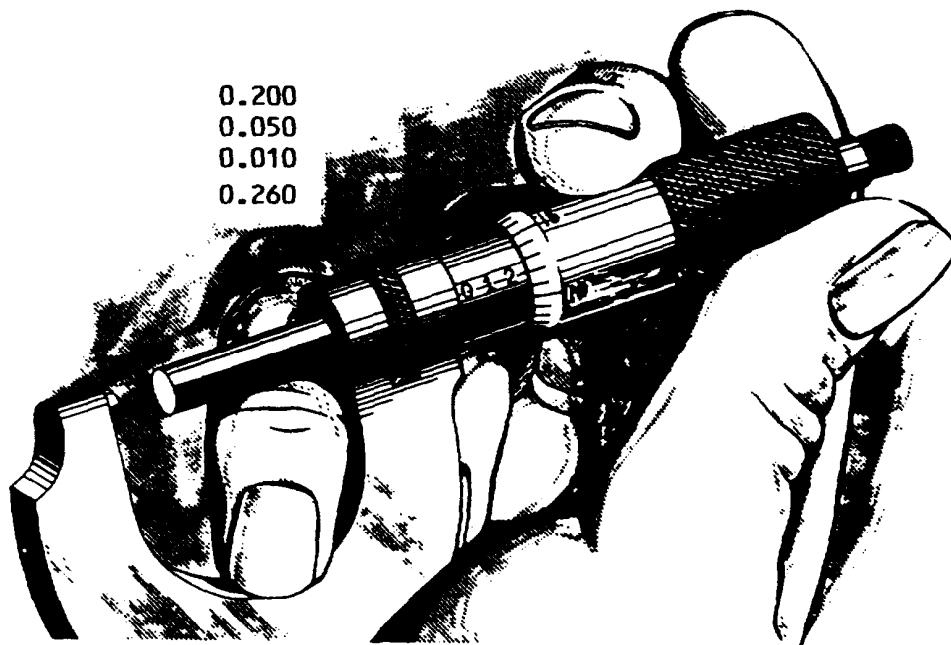

Figure 3-22.—Read a micrometer caliper.

means that the spindle has moved away from the anvil an additional 10 times 0.001 inch, or 0.010 inch. Add this amount to the 0.250 inch sleeve reading, and the total distance is 0.260 inch.

### Reading a Vernier Micrometer Caliper

Many times you are required to work to exceptionally precise dimensions. Under these conditions you should use a micrometer that is accurate to ten thousandths of an inch. This degree of accuracy is obtained by the addition of a vernier scale. This scale (fig. 3-23) furnishes the fine readings between the lines on the thimble rather than making you estimate. The 10 spaces on the vernier are equivalent to 9 spaces on the thimble. Therefore, each unit on the vernier scale is equal to 0.0009 inch, and the difference between the sizes of the units on each scale is 0.0001 inch.

When a line on the thimble scale does not coincide with the horizontal sleeve line, you can determine the additional space beyond the readable thimble mark by finding which vernier mark coincides with a line on the thimble scale. Add this number, as that many ten thousandths of an inch, to the original reading. In figure 3-24, see how the second line on the vernier scale coincides with a line on the thimble scale.

This means that the 0.011 mark on the thimble scale has been advanced an additional 0.0002 of

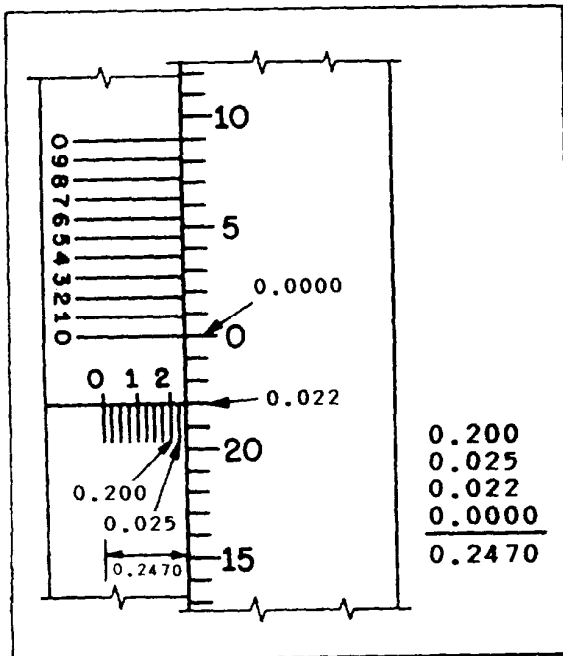

Figure 3-23.—Vernier scale on a micrometer.

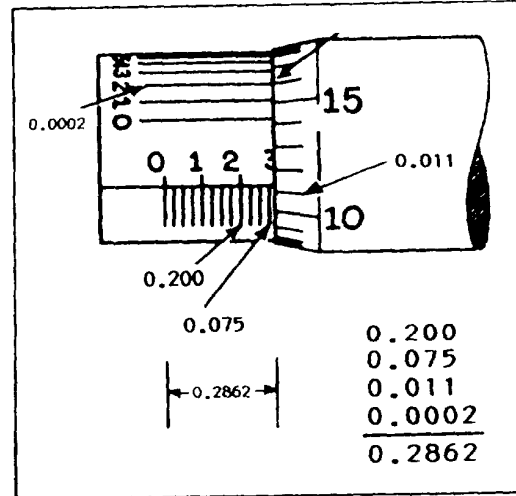

Figure 3-24.—Read a vernier micrometer caliper.

an inch beyond the horizontal sleeve line. When you add this to the other readings, the reading will be  $0.200 + 0.075 + 0.011 + 0.0002 = 0.2862$  of an inch, as shown.

## TEST EQUIPMENT

As a GSE or a GSM, you are responsible for operating various pieces of test equipment when performing maintenance and repair procedures. You must fully understand the operation of this test equipment and must be able to interpret the results of these tests.

Some of the equipment you will find in use are gauge calibration equipment, vibration analysis equipment, horoscopes, fuel testing equipment, and electrical/electronic test equipment.

### DEADWEIGHT TESTER/GAUGE COMPARATOR

Several types of deadweight testers are available. The types are determined by whether the pressure medium is fluid or gas. The fluid deadweight testers use oil or water as the pressure medium; bifluid deadweight testers use oil and water. Pneumatic deadweight testers use a gas, usually pure nitrogen, as the pressure medium.

You will ONLY use the deadweight tester/gauge comparator to compare a gauge to a known pressure. You will do this by applying a pressure with the pump to the standard comparator gauge and the gauge to be compared.

Since the construction details vary for the different types of testers, you should read the manufacturer's catalog or the applicable *Naval*

*Ships' Technical Manual* for specific care and maintenance information.

## ULTRAVIOLET TEST UNIT

The ultraviolet (UV) test unit is a battery-operated unit that outputs an ultraviolet light beam to test the ultraviolet light flame detectors. The test unit is a cylindrical object. It has a pistol type of grip that contains a trigger to control the unit attached to the bottom side of the cylinder.

## HEAT GUN

The heat gun is a device that outputs forced hot air. This is used to test the temperature detectors in the gas turbine enclosure. The heat gun looks and works on the same principle as a blow dryer.

## STROBOSCOPE

The stroboscope is an instrument that permits rotating or reciprocating objects to be viewed intermittently and produce the optical effect of slowing down or stopping motion. For example, electric fan blades revolving at 1,800 rpm will apparently be stationary if viewed under a light that flashes uniformly 1,800 times per minute. At 1,799 flashes per minute, the blades will appear to rotate forward at 1 rpm, and at 1,801 flashes per minute, they will appear to rotate backward at 1 rpm.

The strobotac (fig. 3-25) is an electronic flash device that has a very short flash duration (on the order of a few millionths of a second). This allows very rapid motion to be stopped. The strobotac box contains a swivel mount with a strobotron lamp in a parabolic reflector, an electronic pulse generator that controls the flashing rate, and a power supply that operates from the ac power line. The flashing rate is controlled by the large knob. The corresponding speed in rpm is indicated on an illuminated dial viewed through windows in the knob.

## BORESCOPE

The borescope is an instrument used to inspect the internal parts of the GTE. Inspection is performed by passing a fiber optic probe (rigid or flexible) through parts in the engine. This allows the operator to view the engine parts in the gas flow path.



77.310

Figure 3-25.—Strobotac.

## Function of the Borescope

The word *borescope* is made up of two words. These are *bore*, which means cylindrical cavity (such as in the case of a hydraulic cylinder or gun barrel), and *scope*, which means to observe. In the borescope application of inspecting the gas path components of GTEs, the majority of the observing to be done is at some angle relative to the axis of the borescope inspection hole (port). You can think of the borescope as a type of periscope.

This periscope would be a simple device if it were not for the need to illuminate the object observed. In the equipment described in this



manual, fiber optics are used to transmit light from a remote source to an opening at the end of the borescope probe. The use of fiber optics removes the heat of the bulb from the probe and eliminates the electrical parts from inside it.

The Wolf and Eder borescopes now in use in the fleet are the rigid, probe fiber optic illuminated type. Both borescopes have been manufactured to the same specifications; although some minor design differences exist, their operating principles remain unchanged.

The three basic items that are required for a standard rigid, fiber illuminated borescope setup (fig. 3-26) are as follows:

1. Fiber light projector-A remote unit that supplies the light needed to see the object.
2. Fiber light guide-A flexible cable composed of fiber strands that transmits the light from the light source to the borescope.
3. Probes and adapters-A system of prisms and lenses surrounded by light carrier bundles that transmit light to illuminate the object. The prism and lens system returns the illuminated image from the distal tip to the eye.

## Borescope Use

The borescope is a precision periscope instrument. It is designed for you to inspect the gas path components of GTEs without having to disassemble the engine. The borescope probes (periscopes) contain precision optics that are easily damaged by rough handling. Foam-padded carrying cases are provided to insulate these instruments from shock. The light projector is in one case, and all the remaining equipment is in the other case. Many different kinds of probes and adapters are available from borescope manufacturers. The equipment described in this manual has been selected to meet the inspection requirements of the LM2500 GTE. The need to inspect other machinery, in most instances, requires additional borescoping components of a configuration to be compatible with the geometry of that equipment. Additional borescope accessories needed to inspect any machine other than the LM2500 GTE will be described when we discuss the inspection of that particular piece of equipment.

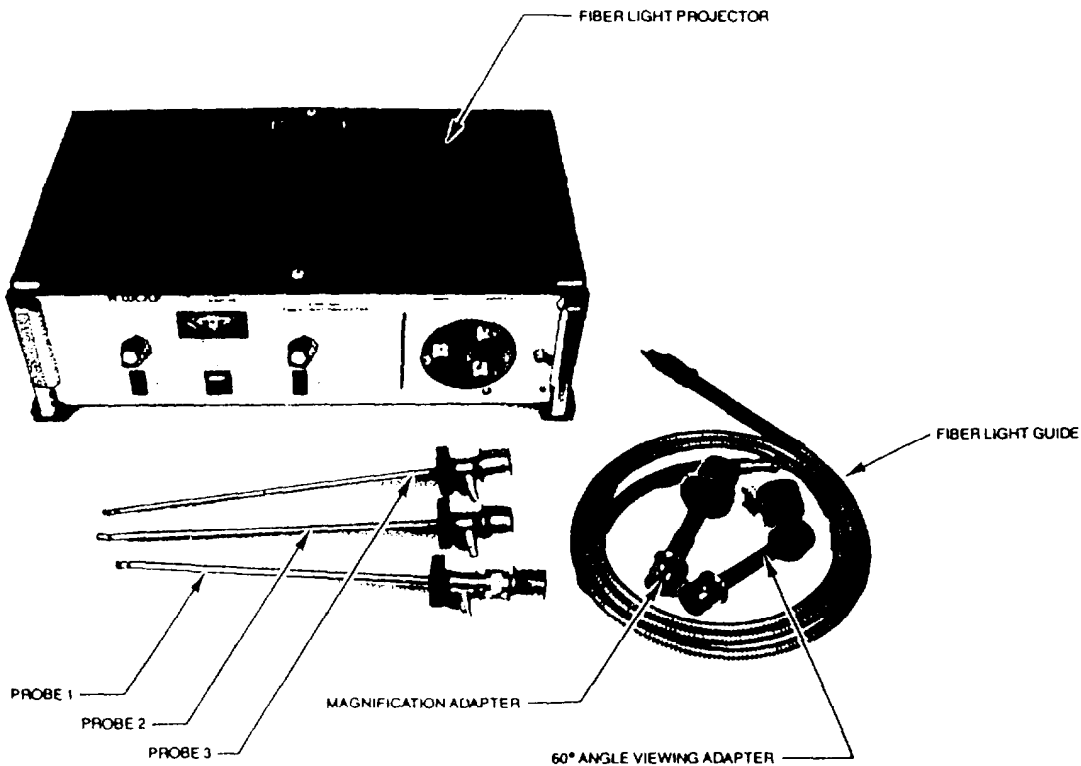

Figure 3-26.—Wolf borescope equipment.

291.181

Three Wolf probes are used for inspecting the LM2500 GTE (fig. 3-27). Each probe has a unique configuration that has special capabilities. The parameters that are varied to achieve these properties are the viewing angle, the field of vision, and the magnifying factor. Understanding the capabilities of each probe will help you find out the best way to use it. The numbering of the probes has nothing to do with their importance or the sequence in which they are used.

Figure 3-27 provides parameters that define the probes. A quick review of these parameters reveals the characteristics of each probe. Probe No. 1, with a 90-degree direction of vision, has a narrow field of view and a high magnification factor. The magnification factor of 1:1 at 7 inches means that an object 7 inches away can be seen as true size, but objects closer than 7 inches can appear magnified. This probe is very difficult to use for searching for an object because of its narrow field of view. Also, its short depth of field requires constant refocusing. The important feature of probe No. 1 is its ability to provide greater magnification to an object already identified (most inspection areas in the LM2500

GTE are less than 7 inches from the inspection ports). Although all probes have been made to the same specification, some variance in the magnification factor is provided by the Wolf and Eder No. 1 probes. The Eder probe has a magnification factor of 1:1 at 5 inches instead of at 7 inches. Eder is working to standardize their probe. However, the user should be aware that it is an Eder and verify the optical characteristics of the probe in his kit.

Probes No. 2 and No. 3 are identical with the exception that No. 2 is looking down (100° from axis of probe) and No. 3 is looking up (70° down from axis of the probe). Objects 2 inches away from the ends of these probes appear at their true size. Objects closer than 2 inches appear magnified, and objects further than 2 inches appear reduced. The advantage of these probes is that they have a wide view and are suited for searching. They also have a large depth of field which does not require constant refocusing. With these probes, all objects 1/4-inch distance from the probe tip to infinity will be in focus.

The direction of view is always given in degrees. Some manufacturers consider the

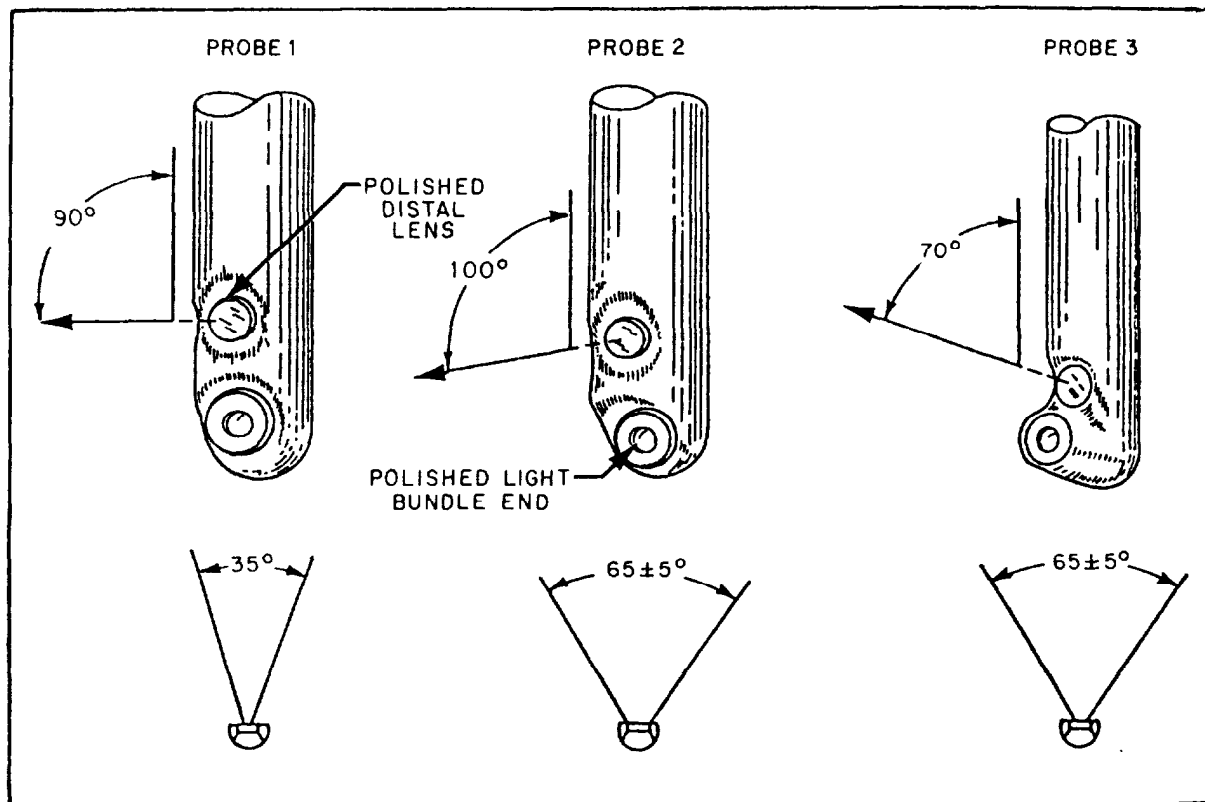

Figure 3-27.—Probe used with Wolf borescope.

eyepiece as 0°; therefore, a direct view scope would be 180° (Wolf). Others start with the probe tip as 0° and count back toward the eyepiece. The Wolf borescope probes (fig. 3-27) use a direction of vision corresponding to the standards of the medical profession.

Borescoping and evaluation of results from an engine inspection are best learned from experience. You should work with an experienced inspector when learning the use of the borescope. Technical manuals provide acceptable and non-acceptable limitations for engine damage; most ships have borescope inspection report sheets. You will turn these sheets in to the chief engineer; they show the inspection results and your evaluations. From these sheets the chief engineer can make the decision to continue to use the engine or to have the engine repaired to operable condition.

## VIBRATION ANALYSIS

Vibration analysis is a method of determining a piece of machinery's mechanical condition by measuring its vibration characteristics under normal operating conditions. Vibration analysis is an extremely effective tool. This analysis can accurately indicate whether a machine has mechanical defects and which specific part is defective.

With a vibration analysis program on board your ship, you can detect machinery problems in their early stages. In this way, you can prevent complete failure of the equipment and possible severe damage to the equipment.

You can use this analysis program to make a baseline profile of new equipment. When doing preventive maintenance, you can compare the



Figure 3-28.—Model 309 vibration meter,

291.169

baseline with the current readings to check the machinery condition. It can also be used to troubleshoot equipment for suspected problems and to verify that proper repairs have been made to overhauled equipment.

The principle of vibration analysis is based on the fact that all machines vibrate. These vibrations are caused by the allowable tolerance errors that are inherent in the machines manufacture; they form the baseline vibration signature of the individual machine. Similar machines have similar vibration signatures that differ from each other only by their manufacturing and installation tolerances.

When a machine's vibration signature changes under its standard operating conditions, the indication is that an impending defect is starting to change the machine's mechanical condition. Different defects cause the vibration signature to change in different ways; thus, the vibration signature provides a means of determining the source of the problem as well as warning of the problem itself.

### Vibration Meter

The information that we provide on vibration meters is a general description of the meters. For information concerning operation of this

equipment, consult the manufacturer's technical manual.

The basic instrument for a vibration preventive maintenance program is the vibration meter. Figure 3-28 shows a typical vibration meter used on board ships. This is a portable, handheld unit that is used for periodic machinery checks. It measures the overall vibration of a machine, which is essentially a summation of all the vibrations present in the machine at the measurement point.

The portable, battery-powered meter is supplied with a carrying case. This case holds the instrument instruction manual, vibration pickup, 4-foot pickup cable, 9-inch probe, magnetic holder, magnetic shield, and meter carrying strap.

### Vibration Analyzers

The vibration analyzer provides a vibration measurement capability beyond that available in the vibration meter. The vibration meter's function is to determine the mechanical condition of machinery by measuring overall vibration amplitude. When the meter detects a mechanical defect, however, it is not capable of pinpointing the specific cause. This is the purpose of the vibration analyzer.

A vibration analyzer (fig. 3-29) contains a tunable filter and a stroboscopic light. You use

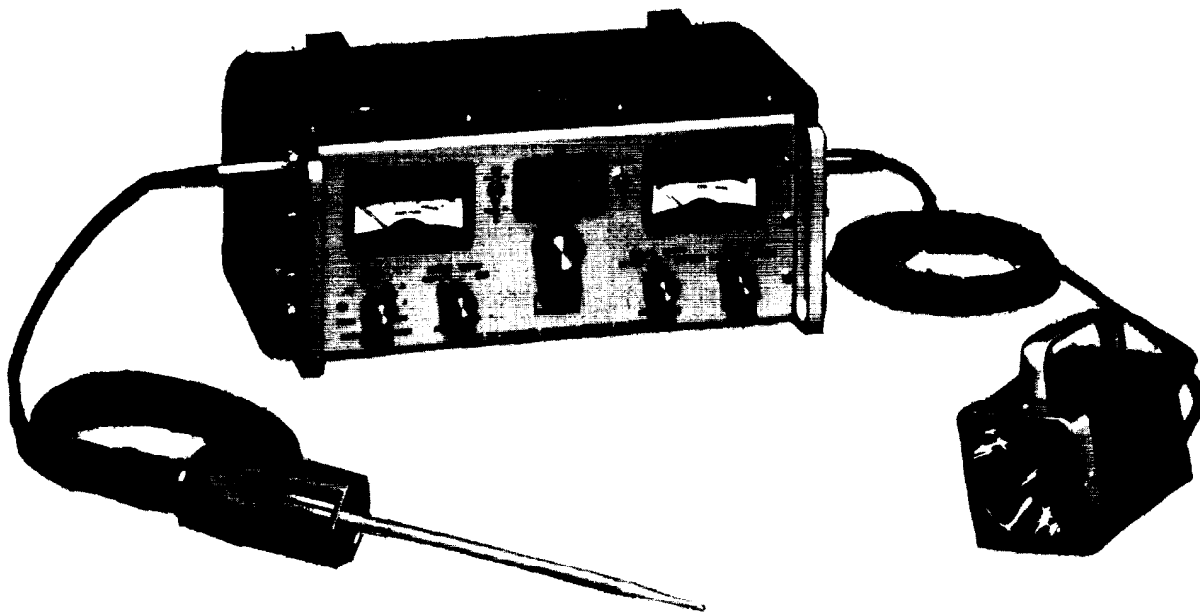

Figure 3-29.—Model 350 vibration analyzer.

these to measure the vibration amplitude, frequency, and phase. These are the three vibration characteristics needed to describe and identify any vibration.

### **PRESSURE TRANSDUCER CALIBRATION KIT**

You will use the pressure transducer calibration kit when performing maintenance on the various pressure transducers. The kit consists of three suitcase type of containers and a dual diaphragm vacuum pump.

The absolute pressure calibration unit is in one container. You will use this unit when calibrating the absolute pressure transducers. The unit has two panel-mounted gauges, a high-pressure regulator, a vacuum/pressure regulator, and a selector valve. The three connection ports are for high-pressure supply, regulated pressure out, and vacuum source.

The gauge pressure and differential pressure calibration unit is in another container. Use this unit when you calibrate the gauge pressure and differential pressure transducers. The unit has

three panel-mounted gauges, a high-pressure regulator, and a selector valve.

The third container provides storage for the multimeter and leads, the nitrogen bottle regulator, and the hose assemblies. The nitrogen bottle is separate and does NOT come with the kit.

Before you calibrate any of the pressure transducers, be sure the gauges on the calibration units do not require calibrating. For detailed instructions, refer to *Propulsion Gas Turbine Module LM2.500, Trouble Isolation*, volume 2, part 3, S9234-AD-MMO-050/LM2500.

### **CENTRIFUGE**

The centrifuge is used to conduct the BS&W test on fuel or to separate different liquids and solids from liquids. The centrifuge (fig. 3-30) consists of a top piece from which four metal tube carriers swing. The carrier holds glass centrifuge tubes graduated to 100 ml. An electric motor rotates the top piece with the tubes. The centrifuge has an adjustable rheostat to select the speed.

To operate the centrifuge, place two tubes with the 100 ml of fuel at opposite ends of the carrier. Then whirl them for 15 minutes at a speed of



**Figure 3-30.—Centrifuge**

1,500 rpm. Read the combined volume of water and sediment at the bottom of each tube. Readings from the tubes are a direct percentage of water and sediment. Determine the BS&W of the fuel, add the readings from the two centrifuge tubes, and divide by two. should repeat this operation until the volume of water and sediment in each tube remains constant for two consecutive readings. In general, you will not have to perform more than four whirlings.

### **PENSKY-MARTENS CLOSED-CUP FLASH POINT TESTER**

The Pensky-Martens closed-cup flash point tester determines the flash point of fuel received on board ship. Figure 3-31 shows the tester, which

contains a cup with a lid, a stirring device, a thermometer, and a heat source.

The flash point of a petroleum product is the lowest temperature at which it gives off sufficient vapors to form a combustible mixture that can be ignited momentarily. Knowledge of the flash point aids you in determining precautionary measures to take against fire and explosion hazards. A flash point substantially lower than expected is a reliable indication of contamination with a highly volatile product (such as aviation gasoline). Contamination of a product can lower its flash point beyond safe handling and storage procedures for that product. This test will also indicate dilution of the product by substances that will cause the flash point to be excessively high. The minimum flash point for all fuel on Navy ships is 140°F.

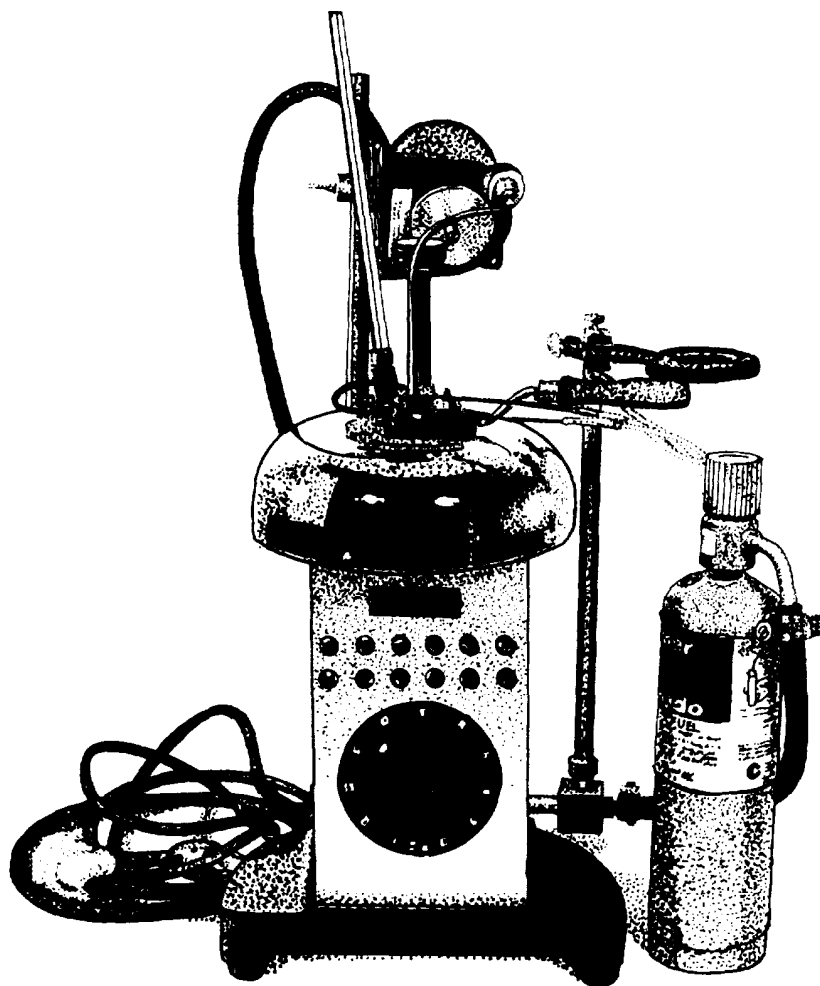

Figure 3-31.—Pensky-Martens closed-cup flash point tester.

## FREE WATER DETECTOR

The Free Water Detector (FWD) (fig. 3-32) is a small portable instrument that quantitatively determines

free or mechanically suspended water present in aircraft fuels. You can use it to test both naval distillate and JP-5. The test procedures for these two fuels differ as do the criteria the fuels must meet.

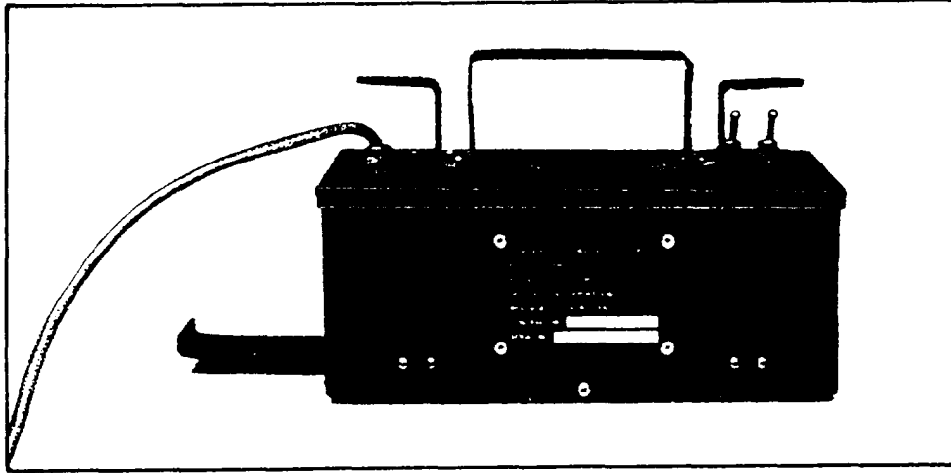

Figure 3-32.—A.E.L. Mk II.

291.100

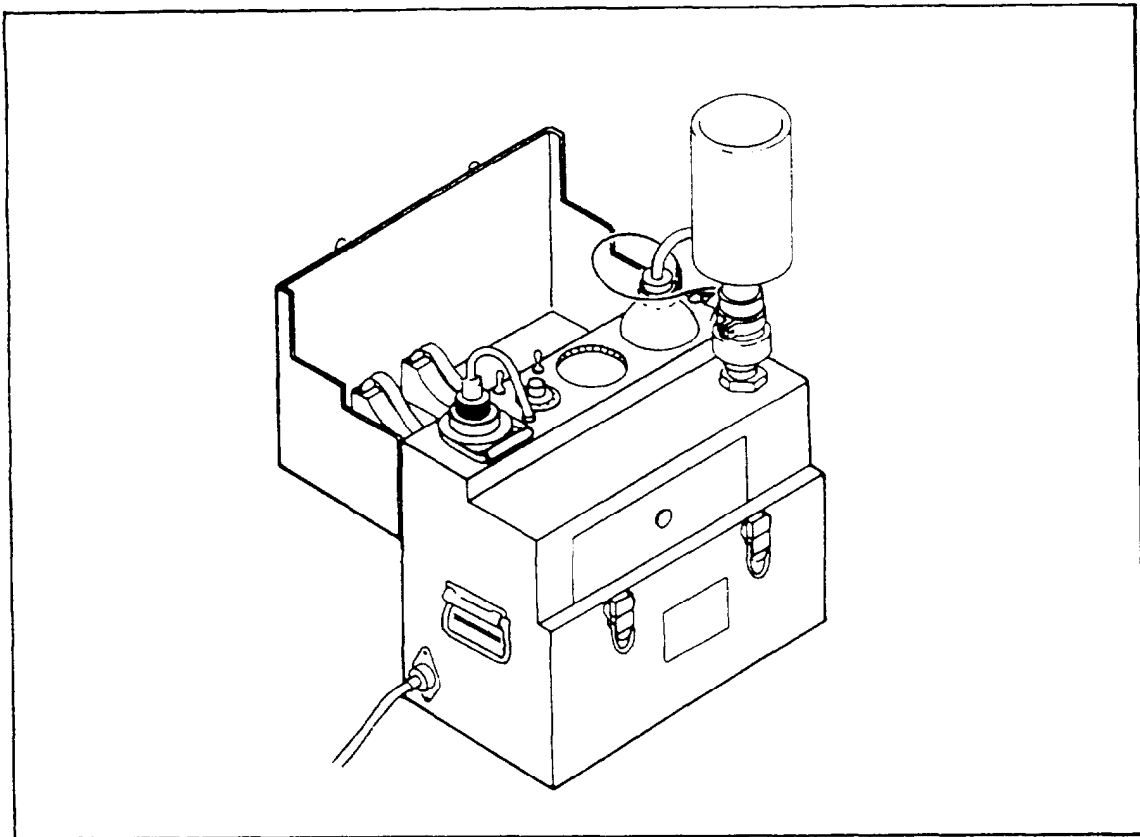

Figure 3-33.—A.E.L. ML III.

The FWD is a small aluminum box containing an UV lamp source for viewing the fluorescence resulting from the reaction of free water in the fuel with a chemical-impregnated test pad. Incorporated into the box are the FWD components necessary for viewing the fluorescence, including the UV light momentary switch, transformer, and test pad holder slider.

### CONTAMINATED FUEL DETECTOR

The Contaminated Fuel Detector (CFD) (fig. 3-33) is a portable instrument that determines the quantity of solid contamination present in naval distillate and JP-5. You are required to have one CFD on board for each type of fuel to maintain your operation fuel quality assurance and aviation certification.

The CFD consists of a fuel sample container, a fuel-millepore filtration system (with the filter), and a light transmission system to determine the quantity of solid contamination on a millepore filter. It is reliable, accurate, and rugged. This fuel detector is capable of providing a quick determination of the quantity of solid contaminants in fuels.

The contaminated fuel detector is a self-contained unit. All components necessary for filtration and measurement of transmitted light are in one serviceable package. A drawer, compartments, and holders are available for storage of filters, sampling bottles, filter holder, power cable, and vital spare parts.

### RESISTANCE BOXES

At one time or another while performing maintenance actions, you will use a resistance box,

sometimes called a decade box. Figure 3-34 shows an example of this box. These boxes, generally oblong in shape, contain variable resistors. On top of the boxes you will see either four, five, or six rotary switches, depending on the type of box used. Each switch will have the numbers 0 through 9 on it. Below each switch you will see a number known as the multiplier. Three terminals are on the right-hand side of the box to connect it with the circuit(s). Some of the boxes may also have a decimal point, such as between switches (3) and (4) in figure 3-34.

The resistance boxes have different ohmic value designations. Printed on the top of the box you will find the upper limit. For example, a 1-kilohm ( $K\Omega$ ) box will range from 0.01 to 999.99 ohms, a 1-megohm ( $M\Omega$ ) box will range from 1 to 999,999 ohms, and so forth.

Each rotary switch on the box controls its own variable resistor. These resistors are arranged so that each resistor's value can be collectively added to each other. Using the figure and reading the switches from left to right, (1) is in the hundreds place, (2) is tens, (3) is ones, (4) is tenths, and (5) is hundredths. To determine the value of a resistor, such as (2) in the figure, read the dial setting, which is 3, and its multiplier, which is  $RX10$ . This becomes  $3R \times 10$  or 30 ohms  $\times 10$ . Therefore, the value of resistor (2) is 30 ohms at this setting. Calculate all of the other resistors in the same manner. Then add the values of each resistor together to get the total resistance of the box. What is the total resistance of the box in figure 3-34? If you figured it out correctly, it would be 730.19 ohms.

You will use these resistance boxes when checking the calibrations of equipment, such as power turbine total inlet pressure ( $P_{t,5,4}$ ) sensors and various transducers.

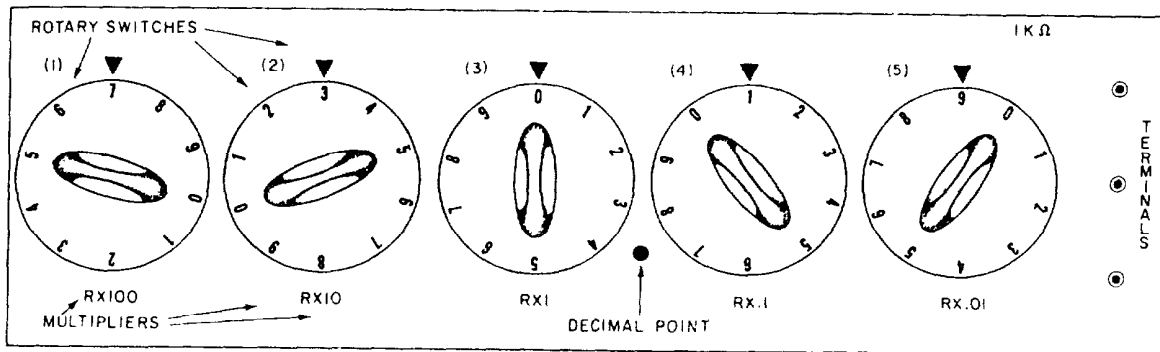

Figure 3-34.—Decade resistance box.



## POWER SUPPLY

The power supply you will use is a portable device. You will use it to perform maintenance or to check equipment operation. The power supply ranges from 0 to 50 volts direct current (dc). This is more than adequate for the majority of your work.

This type of power supply is simple and easy to use. On the front of the power supply are the output controls, a voltage meter, and the terminal connections.

When using a power supply, make sure you follow all safety precautions. Refer to the manufacturer's technical manual for the proper

operating procedures. To avoid damaging the equipment you are working on, know its limits and do not exceed them. When making connections, be sure you observe proper polarity.

## MULTIMETERS

During troubleshooting, you will often be required to measure voltage, current, and resistance. Rather than using three or more separate meters for these measurements, you can use the MULTIMETER. The multimeter contains circuitry that allows it to function as a voltmeter, an ammeter, or an ohmmeter. A multimeter is often called a VOLT-OHM-MILLIAMMETER (vom).

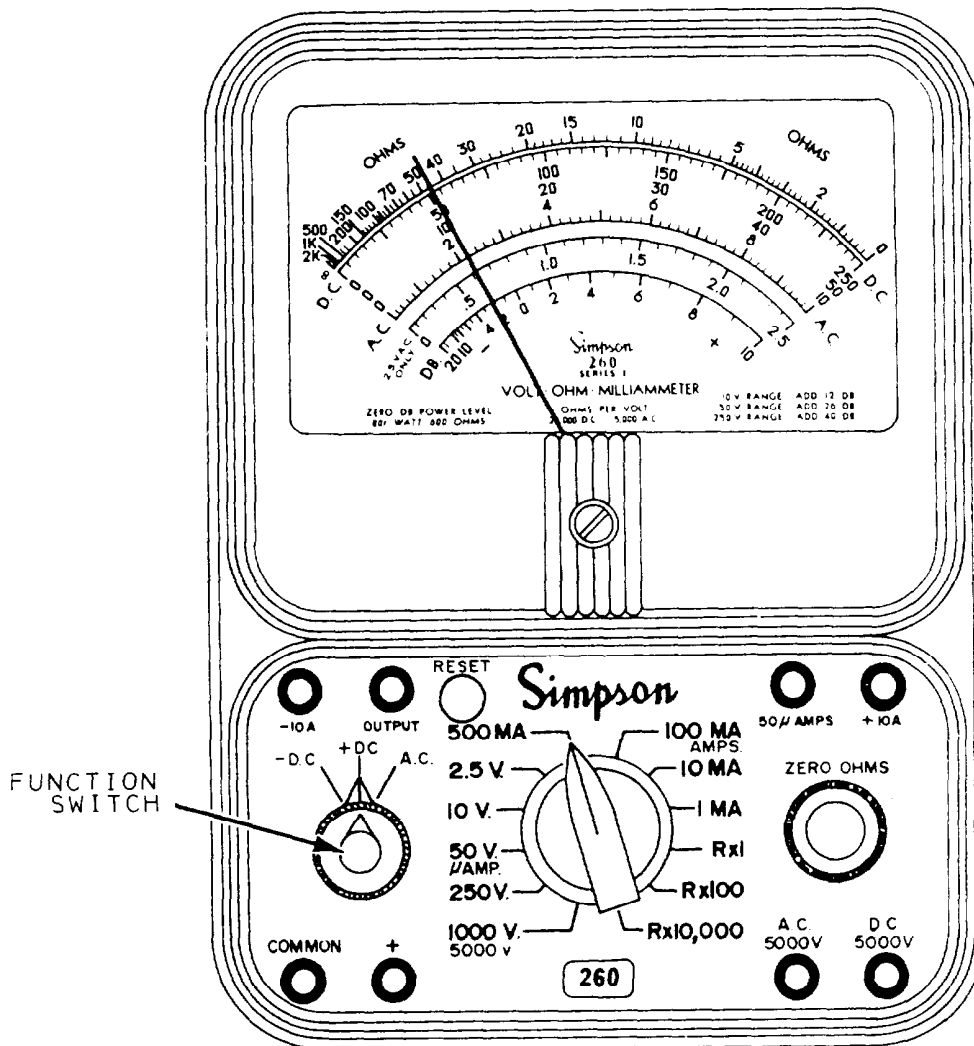

Figure 3-35.—Simpson 260, volt-ohm-milliammeter (vom).

The Simpson 260 multimeter (fig. 3-35) is a typical vom used in the Navy today. It has a meter movement for you to use to take the readings. You must look at the switches to determine which scale to use on the meter. A disadvantage of this type of vom is it tends to "load" the circuit under test.

**ELECTRONIC DIGITAL MULTIMETERS**

The electronic digital multimeter can do the same job as the multimeter. The main difference between the two types of multimeters is the electronic digital multimeter display is digital and it has a higher input impedance. Because of the higher input impedance of the electronic digital multimeter, the loading effect is less and the measurements taken are more accurate.

One example of a typical electronic digital multimeter in use within the Navy is the Model 8000A electronic digital multimeter. Most electronic digital multimeters overcome the disadvantage of requiring a continuous external power source by combining an external ac source with an internal rechargeable battery. Figure 3-36 shows the Model 8000A electronic digital multimeter.

**MEGOHMMETER**

You cannot use an ordinary ohmmeter for measuring multimillion ohm values of resistances, such as those in conductor insulation. To test for such insulation breakdown, you need to use a

much higher potential than that supplied by the battery of an ohmmeter. This potential is placed between the conductor and the outside of the insulation. A megohmmeter (Megger) is used for these tests. Figure 3-37 shows a portable megohmmeter with two main elements: (1) a hand-driven dc generator, which supplies the necessary voltage for making the measurement, and (2) the instrument portion, which indicates the value of the resistance you are measuring.

**OSCILLOSCOPES**

Many different types of oscilloscopes are available. They vary from relatively simple test instruments to highly accurate laboratory models.

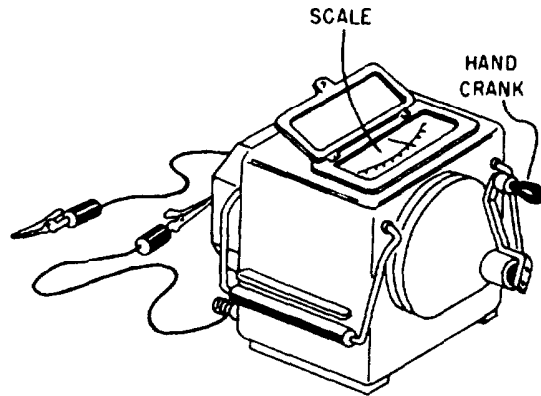

Figure 3-37.—Megohmmeter.

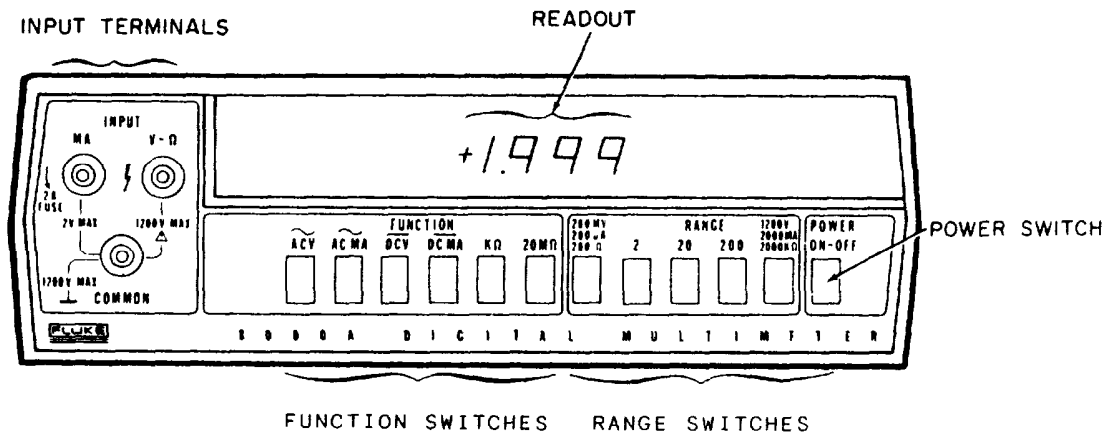

Figure 3-36.—Digital voltmeter operating features.

Figure 3-38 shows the front panel of a dual-trace, general-purpose oscilloscope. It is commonly used in the fleet.

Oscilloscopes vary greatly in the number of controls and connectors. Usually, the more controls and connectors, the more versatile the instrument. Regardless of the number, all oscilloscopes have similar controls and connectors. Once you learn the fundamental operation of these common controls, you can move with relative ease from one model of oscilloscope to another. Occasionally, controls that serve similar functions will be differently labeled from one model to another. However, you will find that most controls are logically grouped and that their names usually indicate their function.

The oscilloscope in figure 3-38 is referred to as a DUAL-TRACE OSCILLOSCOPE. It accepts and displays two vertical signal inputs at the same time—usually for comparison of the two signals or one signal and a reference signal. This scope can also accept just one input. In this case it is used as a SINGLE-TRACE OSCILLOSCOPE.

## SIGNAL GENERATORS

The many types of signal generators (oscillators) vary from relatively simple test instruments to highly accurate laboratory models. Their function is to produce ac of the desired frequency and amplitudes.

One of the primary uses of a signal generator is to set power turbine (PT) speed trip set points. Figure 3-39 shows a typical wide-range oscillator.

## FREQUENCY COUNTERS

Many different types of frequency counters are available. They vary from relatively simple test instruments to highly accurate instruments. Frequency counters function to measure frequencies that already exist.

You can use a frequency counter in conjunction with the signal generator to check the output frequency of a signal generator for more accuracy.

## HYDROMETER

You will be responsible for maintaining the batteries for the uninterruptible power supply

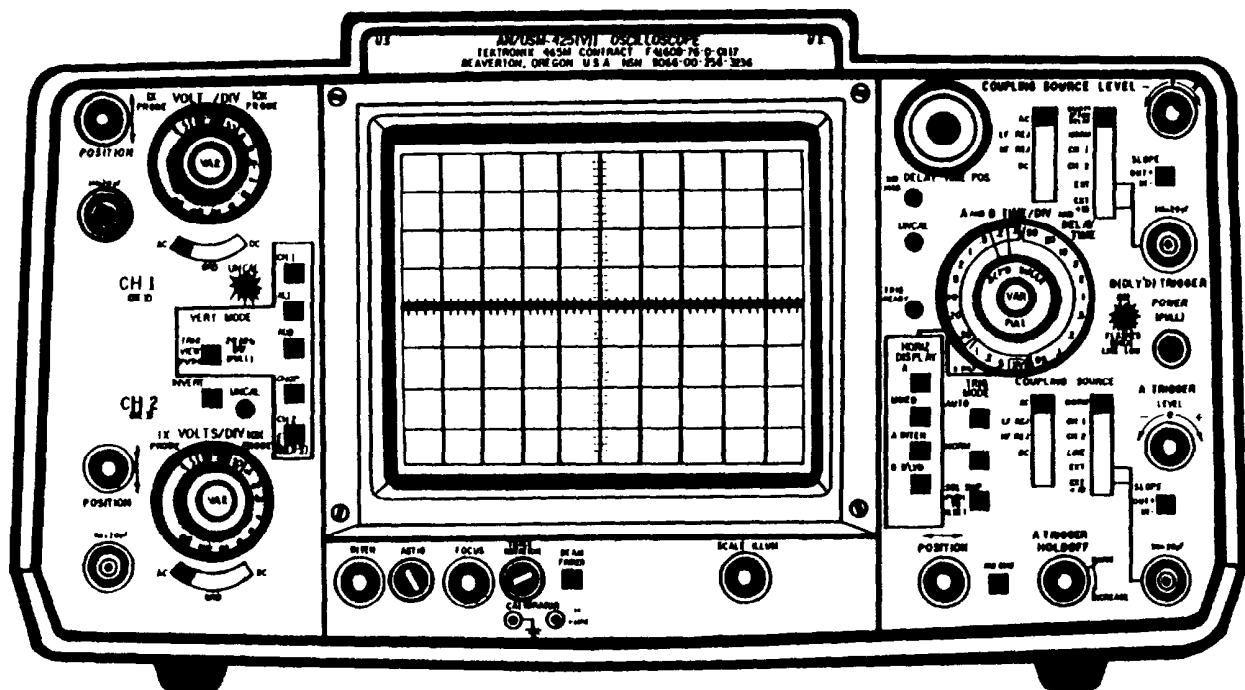
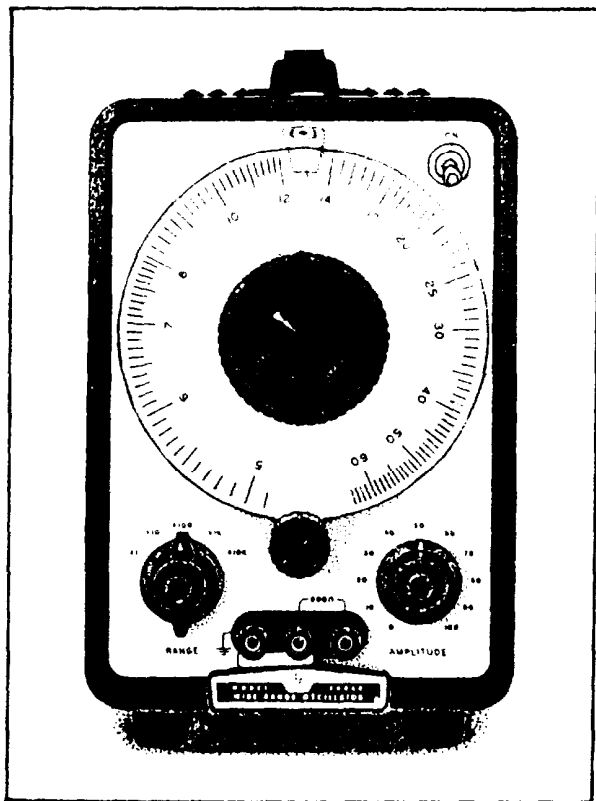

Figure 3-38.—Dual-trace oscilloscope.

298.36



140.144

Figure 3-39.—A typical wide-range oscillator.

(UPS). This section will not cover the batteries, but the tool required to check them. We will discuss batteries in chapters 9 and 10 of this manual.

A hydrometer measures active ingredients in the electrolyte of the battery. The hydrometer measures the SPECIFIC GRAVITY of the electrolyte. Specific gravity is the ratio of the weight of the electrolyte to the weight of the same volume of pure water. The electrolyte's active ingredients, such as sulfuric acid or potassium hydroxide, are heavier than water. Because the active ingredient is heavier than water, the more active ingredient there is in the electrolyte, the heavier the electrolyte will be; the heavier the electrolyte, the higher the specific gravity.

A hydrometer (fig. 3-40) is a glass syringe with a float inside it. The float is a sealed, hollow glass tube weighted at one end. Marked on the side of the float is a scale calibrated in specific gravity. Use the suction bulb to draw the electrolyte into the hydrometer. Make sure enough electrolyte is drawn into the hydrometer for the float to rise.

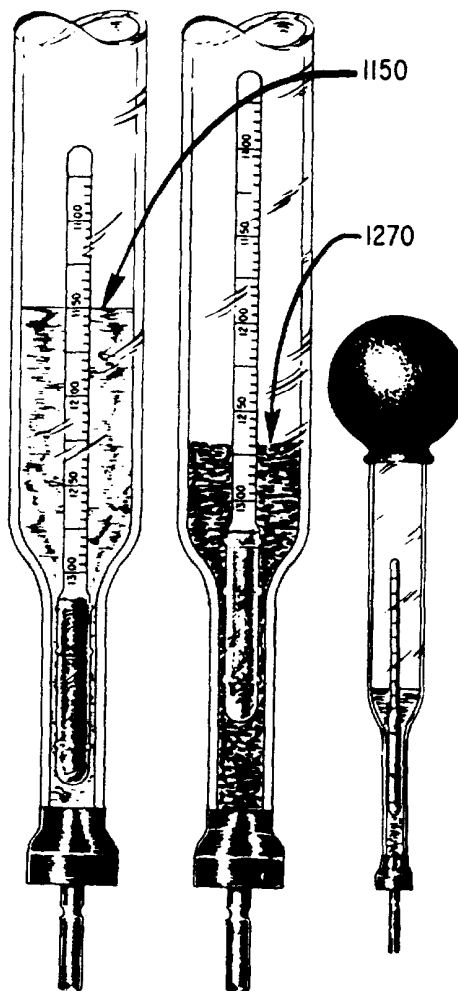

Figure 3-40.—Hydrometer.

Do not fill the hydrometer too much so that the float rises into the suction bulb.

Since the weight of the float is at its base, the float will rise to a point determined by the weight of the electrolyte. If the electrolyte has a large concentration of active ingredient, the float will rise higher than if the electrolyte has a small concentration of active ingredient.

To read the hydrometer, hold it in a vertical position and take the reading at the level of the electrolyte. Refer to the manufacturer's technical manual for battery specifications for the correct specific gravity ranges.

**NOTE: Flush hydrometers with fresh water after each use to prevent inaccurate readings. Do not use storage battery hydrometers for any other purpose.**

When working with batteries, ensure you wear proper protective clothing (such as safety glasses, rubber gloves, rubber apron, and rubber boots). The battery water contains acids which can ruin clothes and cause severe burning. Be sure you follow the safety precautions found in *Naval Ships' Technical Manual*, Chapter 313, "Portable Storage and Dry Batteries," and those found on the PMS card.

## HOISTING AND LIFTING DEVICES

When performing maintenance, you may have to move or lift some of the heavy equipment or components. You can use various devices to do this. The selection of the proper device depends on many factors, such as the equipment to be moved and the available work space. A working knowledge of the following devices will aid you in selecting the right device.

### CHAIN HOISTS

Chain hoists (chain falls) provide an easy and efficient method for hoisting loads by hand. The advantages of chain hoists are that one person can raise a load of several tons, and the load can remain stationary without being secured. A chain hoist permits small movements, accurate adjustment of height, and gentle handling of loads. For these reasons they are particularly useful in hoisting motors or parts which must be precisely aligned with other parts. Two of the most common types used for vertical hoisting operations are the differential chain hoist and the spur gear hoist (fig. 3-41). The load capacity of a chain hoist can range from 1/2 ton to 40 tons and is stamped on the shell of the upper block.

The differential chain hoist is suitable for light loads. This hoist is only about 35 percent efficient. In other words, about 35 percent of the energy that you exert is converted into useful work for lifting the load. The remaining 65 percent of the energy is spent in overcoming friction in the gears, bearings, and chains.

The spur gear hoist is used for operations that require frequent use of a hoist and where few personnel are available to operate it. The spur gear hoist is about 85 percent efficient.

The lower hook is usually the weakest part in the assembly of a chain hoist. This is intended as a safety measure so the hook will start to spread open if overloaded. Thus, you must closely watch the hook to detect any sign of overloading in time to prevent damage.

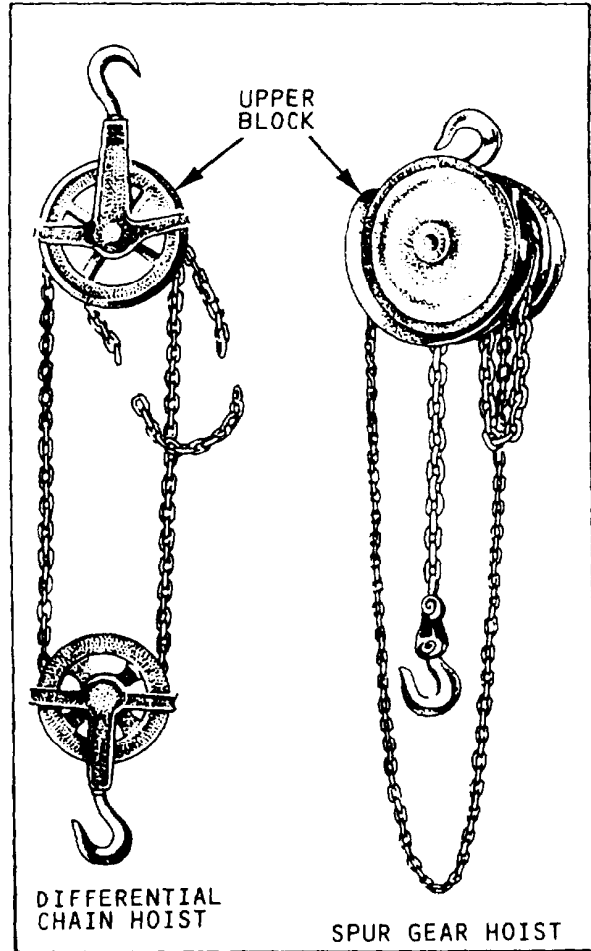

Figure 3-41.—Chain hoists.

Before using a chain hoist, inspect it to ensure safe operation. Replace a hook that shows signs of spreading or excessive wear. If links in the chain are distorted, the chain hoist has probably been overloaded. Make sure the hoist is in good repair before attempting to lift a load.

### HAND-OPERATED RATCHET LEVER HOISTS

Hand-operated ratchet lever hoists (fig. 3-42), more commonly called come-a-longs, are similar to the chain hoist. The main difference is that you operate a ratchet handle to move the load vice a chain. The direction of movement is changed by a lever on the side of the unit or in the handle.

Compared to the chain hoist, the come-a-long is smaller because of the size difference of the top

portion of the units. The come-a-long is used in maintenance as is the chain hoist; however, because the ratchet mechanism does not allow for minimal movements, it is NOT recommended for use in the alignment of parts.

**PUSH-PULL HYDRAULIC JACK**

A push-pull hydraulic jack, commonly called a port-a-power, consists of a pump and ram connected by a flexible hose (fig. 3-43). Jacks of

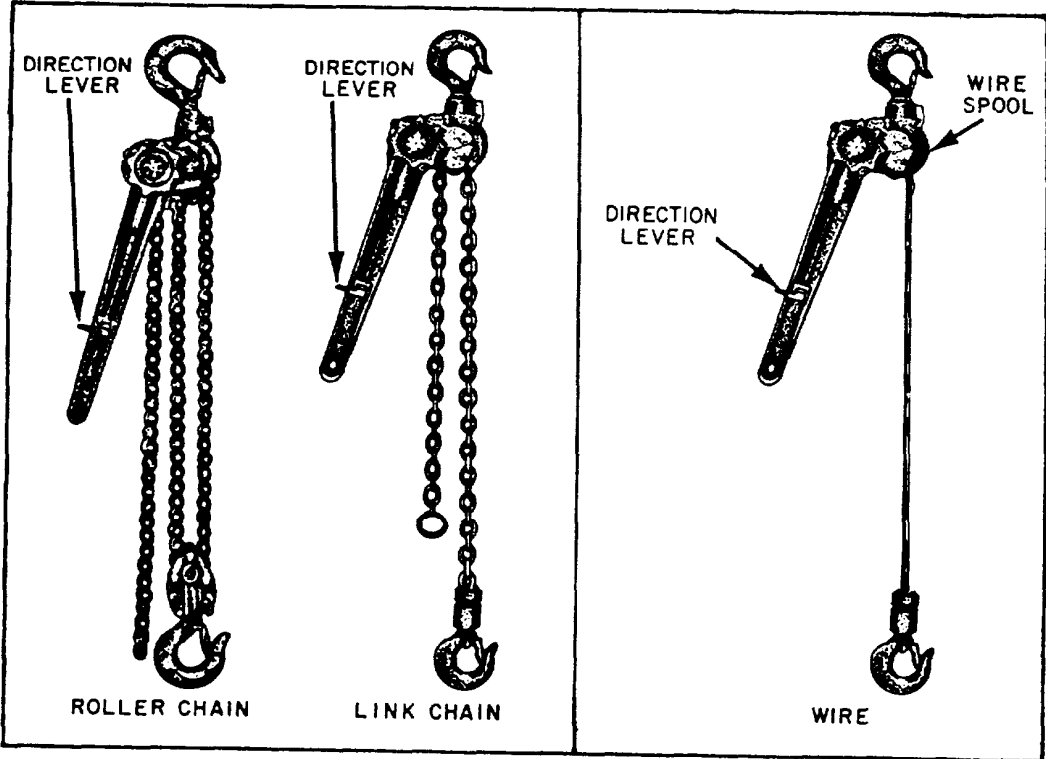

Figure 3-42.—Hand-operated ratchet lever hoist (come-a-long).

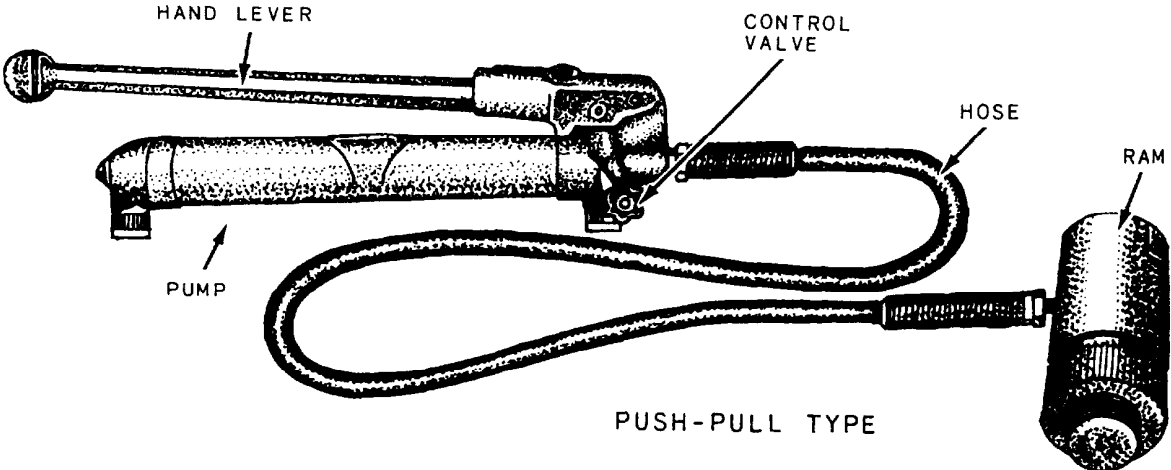

Figure 3-43.—Push-pull hydraulic jack (port-a-power).

226.27.1

this type are rated at 2-, 7-, 20-, 30-, and 100-ton capacities and have diversified applications. These jacks are furnished with an assortment of attachments. These attachments enable you to perform countless pushing, pulling, lifting, pressing, bending, spreading, and clamping operations. The pump is hand operated. A flexible hydraulic hose allows you to operate the ram in any desired position and from a safe distance. You can retract the ram automatically by turning a single control valve.

When using the port-a-power to raise a part, make certain no one is under the part. Keep fingers away from all moving parts. Be sure to place blocking or other supports under the part when it is raised to the desired height to prevent it from dropping if the jack fails. Before using a hydraulic jack of any type, make sure it is filled with fluid and has no apparent leaks.

## CRANES

As a general rule, the cranes you use are located pierside. The crane is used when equipment must be moved to a pierside facility, such as a shore intermediate maintenance activity (SIMA), for overhaul. The ship's personnel generally moves any equipment to the main deck of your ship, and then the crane operator off-loads it. Obviously, when removing a GTE, the ship's personnel do not move the engine topside. In this situation, the crane drops its hook down the inlet plenum of the GTE. Special rails are installed in the inlet plenum to facilitate the removal.

**NOTE: Before you use any of the hoisting and lifting devices, ensure that they are in good working order. If you use beam clamps, C-clamps, or wire straps, make sure they are secured properly and in good condition before attaching the lifting devices to them.**

## SUMMARY

In this chapter we have introduced you to some of the tools and test equipment that you will use during maintenance or while performing operational checks. We have not covered all of the equipment you will use because either you are already familiar with them or they are specialized equipment for use in specific instances. One example of this specialized equipment is the special support equipment for the LM2500 GTE. NAVSEA Technical Manual S9234-AA-MMA-000/LM2500 covers the special equipment used in conjunction with the LM2500 GTE. It will provide you with a good description of the function of this equipment.

You will find that an in-depth knowledge of test equipment is especially useful in troubleshooting equipment problems, and an understanding of the use of the correct tools at the proper time will make you a more efficient technician. Remember, for further information refer to *Use and Care of Hand Tools and Measuring Tools*, NAVEDTRA 12085, and Navy Electricity and Electronics Training Series (NEETS), modules 1, 3, and 16. You should also consult each equipment's technical manual for the correct test equipment operation and proper use.

## CHAPTER 4

# ELECTRICAL THEORY AND MECHANICAL THEORY

In this chapter we will discuss electrical theory and mechanical theory and how you will use these theories in the everyday performance of your assigned tasks. During our discussion we will demonstrate a few examples of the theories that are pertinent and/or necessary to you at your level of training. You need to understand the basic laws and principles of electrical theory and mechanical theory to form a foundation for the further development of your knowledge. It is our intention to ensure you understand the basics before you attempt the practical application of these theories. The practical application of electrical theory and mechanical theory will be discussed in later chapters. To fully grasp and understand the laws and principles discussed in this chapter, you should be familiar with the knowledge provided in the NEETS training modules 1 through 5 and *Basic Machines*, NAVEDTRA 10624-A.

After studying this chapter, you should be able to (1) state the pertinent laws and principles of electrical theory (Ohm's, Kirchhoff's, Coulomb's, and the law of magnetism); (2) recognize the requirements needed to produce and the various methods used for electric power generation; (3) state the basic laws and principles of mechanical theory (Charles's, Boyle's, Pascal's, and Newton's first, second, and third laws, and Bernoulli's principle); (4) describe energy and explain its different forms; (5) relate the theory of leverage to the moving and lifting of objects; (6) recognize the different temperature scales and point out their relationship to each other; and (7) identify the different types of pressure (gauge, atmospheric, barometric, and absolute) and point out their relationship to each other.

### ELECTRICAL THEORY

Electrical theory is just that, THEORY. Presently, little more is known than the ancient Greeks knew about the fundamental nature of

electricity, but tremendous strides have been made in harnessing and using it. Elaborate theories concerning the nature and behavior of electricity have been advanced and have gained wide acceptance because of their apparent truth and demonstrated workability.

### LAWS

By learning the rules and laws applying to the behavior of electricity and by understanding the methods used to produce and control electricity, you may learn about electricity without ever having determined its fundamental identity. Your persistence and ability to sort out facts and ask detailed questions will determine how thoroughly you understand electrical theory and laws, and how they pertain to you. For an indepth discussion of the basic laws of electricity, you should study NEETS, module 1.

#### Ohm's Law

In the early part of the nineteenth century, George Simon Ohm proved by experiment that a precise relationship exists between current, voltage, and resistance. This relationship is called **Ohm's law**. It states that

**the current in a circuit is DIRECTLY proportional to the applied voltage and INVERSELY proportional to the circuit resistance.**

Simply stated, this means that as the resistance in a circuit increases, the current decreases proportionally.

#### Kirchhoff's Voltage Law

In 1847, G. R. Kirchhoff extended the use of Ohm's law by developing a simple concept



concerning the voltages contained in a series loop. **Kirchhoff's law** states that

**the algebraic sum of the voltage drops in any closed path in a circuit and the electromotive forces in that path are equal to zero.**

To state Kirchhoff's law another way, the voltage drops and voltage sources in a circuit are equal at any given moment in time. If the voltage sources are assumed to have one sign (positive or negative) at that instant and the voltage drops are assumed to have the opposite sign, the result of adding the voltage sources and voltage drops will be zero. For more detailed information on the use and application of Kirchhoff's law, refer to chapter 3 of NEETS, module 1.

**NOTE: In applying Kirchhoff's law to direct current (dc) circuits, the term electromotive force (emf) applies to voltage sources, such as batteries or power supplies. Kirchhoff's law is also used in alternating current (ac) circuits (which are covered in NEETS, module 2).**

### **Coulomb's Law**

The relationship between attracting or repelling charged bodies was first discovered by a French scientist named Charles A. Coulomb. **Coulomb's law** states that

**charged bodies attract or repel each other with a force that is directly proportional to the product of their individual charges, and is inversely proportional to the square of the distance between them.**

Simply stated, the amount of attracting or repelling force which acts between two electrically charged bodies in free space depends on two things—(1) their charges and (2) the distance between them.

### **Law of Magnetism**

To properly understand the principles of electricity, you need to understand magnetism and the effects of magnetism on electrical equipment. Magnetism and electricity are so closely related that knowledge of either subject would be incomplete without at least a basic knowledge of the other.

Much of today's modern electrical and electronic equipment could not function without magnetism. Modern computers, tape recorders, and video reproduction equipment use magnetized tape and/or discs. High-fidelity speakers use magnets to convert amplifier outputs into audible sound. Electrical motors use magnets to convert electrical energy into mechanical motion; generators use magnets to convert mechanical motion into electrical energy. Simply stated, the **law of magnetism** states that

**like poles repel, unlike poles attract.**

**MAGNETIC FIELDS.**—The space surrounding a magnet where magnetic forces act is known as the magnetic field. You can prove that the magnetic field is very strong at the poles and weakens as the distance from the poles increases by conducting simple experiments. It will also be apparent that the magnetic field extends from one pole to the other, constituting a loop about the magnet.

Although magnetic lines of force are imaginary, a simplified version of many magnetic phenomena can be explained by assuming the magnetic lines to have certain real properties. The lines of force can be compared to rubber bands, which stretch outward when a force is exerted upon them and contract when the force is removed. The characteristics of magnetic lines of force can be described as follows:

1. Magnetic lines of force are continuous and will always form closed loops.
2. Magnetic lines of force will never cross one another.
3. Parallel magnetic lines of force traveling in the same direction repel one another. Parallel magnetic lines of force traveling in opposite directions tend to unite with each other and form into single lines traveling in a direction determined by the magnetic poles creating the lines of force.
4. Magnetic lines of force tend to shorten themselves. Therefore, the magnetic lines of force existing between two unlike poles cause the poles to be pulled together.
5. Magnetic lines of force pass through all materials, both magnetic and nonmagnetic.
6. Magnetic lines of force always enter or leave a magnetic material at right angles to the surface.

**MAGNETIC EFFECTS.**—The total number of magnetic lines of force leaving or entering the

pole of a magnet is called the **MAGNETIC FLUX**. The number of flux lines per unit area is known as **FLUX DENSITY**. The intensity of a magnetic field is directly related to the magnetic force exerted by the field. The force between two poles is directly proportional to the product of the pole strengths and inversely proportional to the square of the distance between the two poles.

Magnetism can be induced in a magnetic material by several means. The magnetic material may be placed in the magnetic field, brought into contact with a magnet, or stroked by a magnet. Stroking and contact both indicate actual contact with the material but are considered in magnetic studies as magnetizing by **INDUCTION**.

**MAGNETIC SHIELDING.**—There is no known **INSULATOR** for magnetic flux. If a non-magnetic material is placed in a magnetic field, there is no appreciable change in flux—that is, the flux penetrates the nonmagnetic material. If a magnetic material (for example, soft iron) is placed in a magnetic field, the flux may be redirected to take advantage of the greater permeability of the magnetic material, as shown in figure 4-1. Permeability is the quality of a substance that determines the ease with which it can be magnetized.

The sensitive mechanisms of electric instruments and meters can be influenced by stray magnetic fields, which will cause errors in their readings. Because instrument mechanisms cannot be insulated against magnetic flux, it is necessary to employ some means of directing the flux around the instrument. This is accomplished by placing a soft-iron case, called a **MAGNETIC SCREEN** or **SHIELD**, about the instrument. Because the flux is established more readily through the iron (even though the path is longer)

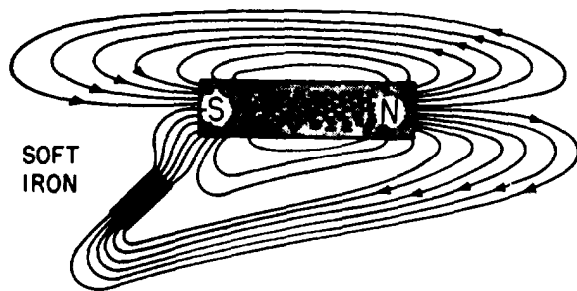

Figure 4-1.—Effects of a magnetic substance in a magnetic field.

than through the air inside the case, the instrument is effectively shielded, as shown by the watch and soft-iron shield in figure 4-2.

For further information on magnetism, you should refer to **NEETS**, module 1.

## ELECTRICAL POWER GENERATION

A generator is a machine that converts mechanical energy to electrical energy using the **principle of magnetic induction**. This principle is based on the fact that

**if a conductor is moved within a magnetic field in such a way that the conductor cuts across magnetic lines of force, voltage is generated in the conductor.**

The **AMOUNT** of voltage generated depends on (1) the strength of the magnetic field, (2) the angle at which the conductor cuts the magnetic field, (3) the speed at which the conductor is moved, and (4) the length of the conductor within the magnetic field.

The **POLARITY** of the voltage depends on the direction of the magnetic lines of flux and the direction of movement of the conductor.

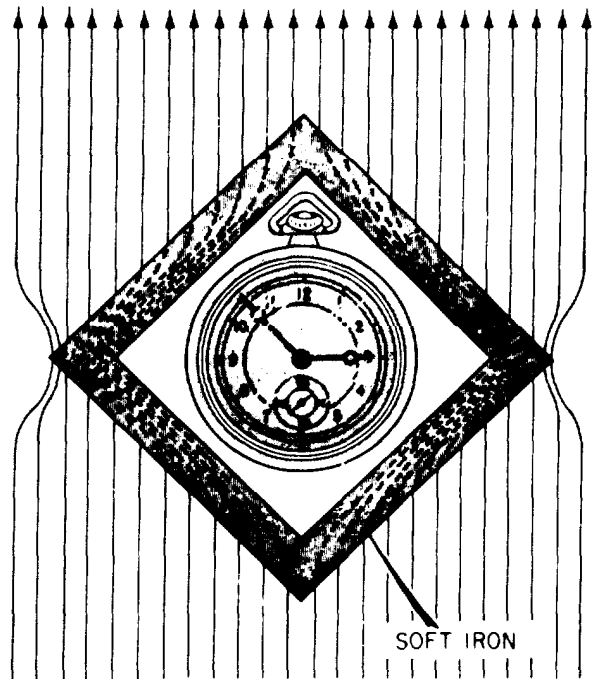

Figure 4-2.—Magnetic shield.

## Methods of Producing Electrical Power

The following is a list of the six most common methods of producing emf. Some of these methods are much more widely used than others. We will first define the methods for you, and then we will discuss them in more detail.

1. **MAGNETISM**—Voltage produced in a conductor when the conductor moves through a magnetic field, or when a magnetic field moves through the conductor in such a manner as to cut the magnetic lines of force of the field.

2. **FRICTION**—Voltage produced by rubbing two materials together.

3. **PRESSURE** (piezoelectricity)—Voltage produced by squeezing crystals of certain substances.

4. **HEAT** (thermoelectricity)—Voltage produced by heating the joint (junction) where two unlike metals are joined.

5. **LIGHT** (photoelectricity)—Voltage produced by light striking photosensitive (light sensitive) substances.

6. **CHEMICAL ACTION**—Voltage produced by chemical reaction in a battery cell.

## VOLTAGE PRODUCED BY MAGNETISM.

Magnets or magnetic devices are used for thousands of different jobs. One of the most useful and widely employed applications of magnets is in the production of vast quantities of electric power from mechanical sources. The mechanical power may be provided by a number of different sources, such as gasoline or diesel engines and water or steam turbines. However, the final conversion of these source energies to electricity is done by generators employing the principle of electromagnetic induction. We will discuss here the fundamental operating principle of all such electromagnetic induction generators.

To begin with, three fundamental conditions must exist before a voltage can be produced by magnetism. These conditions are

1. a **CONDUCTOR**, in which the voltage will be produced,

2. a **MAGNETIC FIELD** in the conductor's vicinity, and

3. a **RELATIVE MOTION** between the field and the conductor. The conductor must be moved so as to cut across the magnetic lines of force, or the field must be moved so that the lines of force are cut by the conductor.

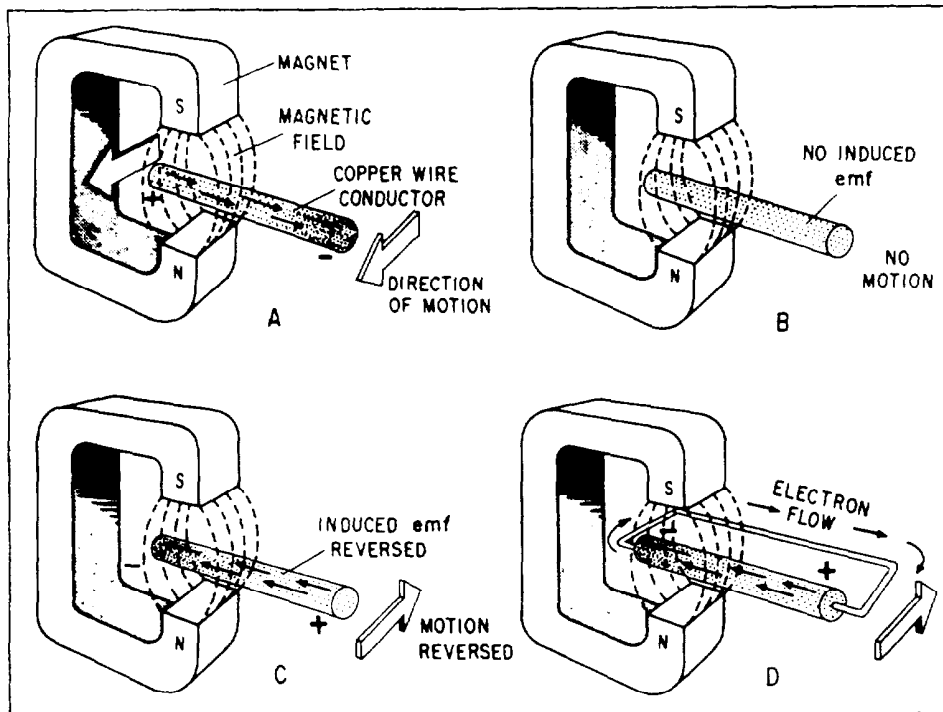

Figure 4-3.—Voltage produced by magnetism.

According to these conditions, when a conductor or conductors move across a magnetic field so as to cut the lines of force, electrons within the conductor are impelled in one direction or another. Thus, an electric force, or voltage, is created.

In figure 4-3, note the presence of the three conditions needed for creating an induced voltage:

1. There is a conductor (copper wire).
2. There is a magnetic field between the poles of the C-shaped magnet.
3. There is relative motion. The wire is moved back and forth **ACROSS** the magnetic field.

In figure 4-3, view A, the conductor is moving **TOWARD** the front of the page. The right-hand end becomes negative, and the left-hand end becomes positive. This occurs because of the magnetically induced emf acting on the electrons in the copper. The conductor is stopped, view B, motion is eliminated (one of the three required conditions), and there is no longer an induced emf. Consequently, there is no longer any difference in potential between the two ends of the wire. The conductor at view C is moving away from the front of the page. An induced emf is again created. However, note carefully that the **REVERSAL OF MOTION** has caused a **REVERSAL OF DIRECTION** in the induced emf.

If a path for electron flow is provided between the ends of the conductor, electrons will leave the negative end and flow to the positive end. This condition is shown in view D. Electron flow will continue as long as the emf exists. In studying figure 4-3, note that the induced emf could also have been created by holding the conductor stationary and moving the magnetic field back and forth.

#### **VOLTAGE PRODUCED BY FRICTION.—**

This is the least used of the six methods of producing voltages. Its main application is in Van de Graf generators, used by some laboratories to produce high voltages. As a rule, friction electricity (often referred to as static electricity) is a nuisance. For instance, a flying aircraft accumulates electric charges from the 'friction between its skin and the passing air. These charges often interfere with radio communication, and

under some other circumstances can even cause physical damage to the aircraft. Most individuals are familiar with static electricity and have probably received unpleasant shocks from friction electricity upon sliding across dry seat covers or walking across dry carpets, and then coming in contact with some other object.

#### **VOLTAGE PRODUCED BY PRESSURE.—**

This action is referred to as piezoelectricity. It is produced by compressing or decompressing crystals of certain substances. To study this form of electricity, the meaning of the word *crystal* must first be understood. In a crystal, the molecules are arranged in an orderly and uniform manner. Figure 4-4 shows a substance in its non-crystallized state and its crystallized state.

For the sake of simplicity, assume that the molecules of this particular substance are spherical (ball-shaped). In the noncrystallized state, view A, note that the molecules are arranged irregularly. In the crystallized state, view B, the molecules are arranged in a regular and uniform manner. This illustrates the major physical difference between crystal and noncrystal forms of matter. Natural crystalline matter is rare; an example of matter that is crystalline in its natural form is diamond, which is crystalline carbon. Most crystals are manufactured.

Crystals of certain substances, such as Rochelle salt or quartz, exhibit peculiar electrical characteristics. These characteristics, or effects, are referred to as piezoelectric. For instance, when a crystal of quartz is compressed, as in

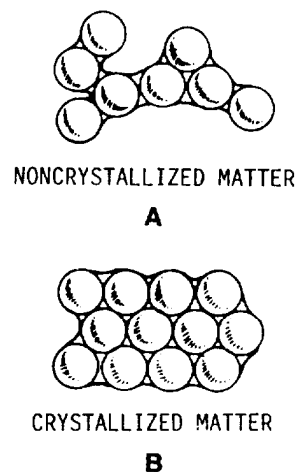

Figure 4-4.—Molecules of noncrystallized and crystallized matter.

figure 4-5, view A, electrons tend to move through the crystal as shown. This tendency creates an electrical difference of potential between the two opposite faces of the crystal. (The fundamental reasons for this action are not known. However, the action is predictable, and therefore useful.) If an external wire is connected while the pressure and emf are present, electrons will flow. If the pressure is held constant, the electron flow will continue until the charges are equalized. When

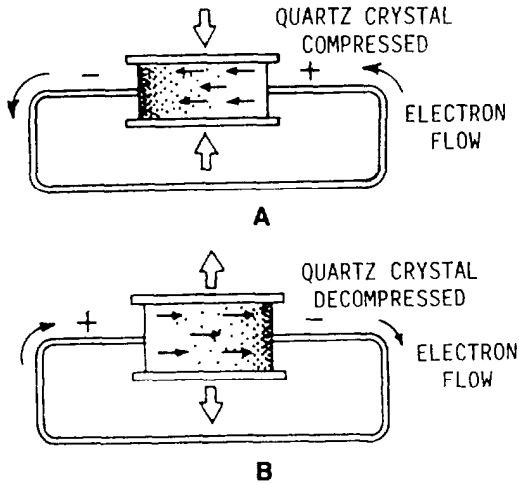

Figure 4-5.—Quartz crystal. A. Compressed. B. Decompressed.

the force is removed, the crystal is decompressed and immediately causes an electric force in the opposite direction, view B. Thus, the crystal is able to convert mechanical force, either pressure or tension, to electrical force.

The power capacity of a crystal is extremely small. However, they are useful because of their extreme sensitivity to changes of mechanical force or changes in temperature. Due to other characteristics not mentioned here, crystals are most widely used in communication equipment.

#### VOLTAGE PRODUCED BY HEAT.—

When a length of metal, such as copper, is heated at one end, electrons tend to move away from the hot end toward the cooler end. This is true of most metals. However, in some metals, such as iron, the opposite takes place and electrons tend to move TOWARD the hot end. Figure 4-6 shows this characteristic. The negative charges (electrons) are moving through the copper away from the heat and through the iron toward the heat. They cross from the iron to the copper at the hot junction and from the copper through the current meter to the iron at the cold junction. This device is generally referred to as a thermocouple.

Thermocouples have somewhat greater power capacities than crystals, but their capacity is still very small if compared to some other sources. The thermoelectric voltage in a thermocouple depends mainly on the difference in temperature between

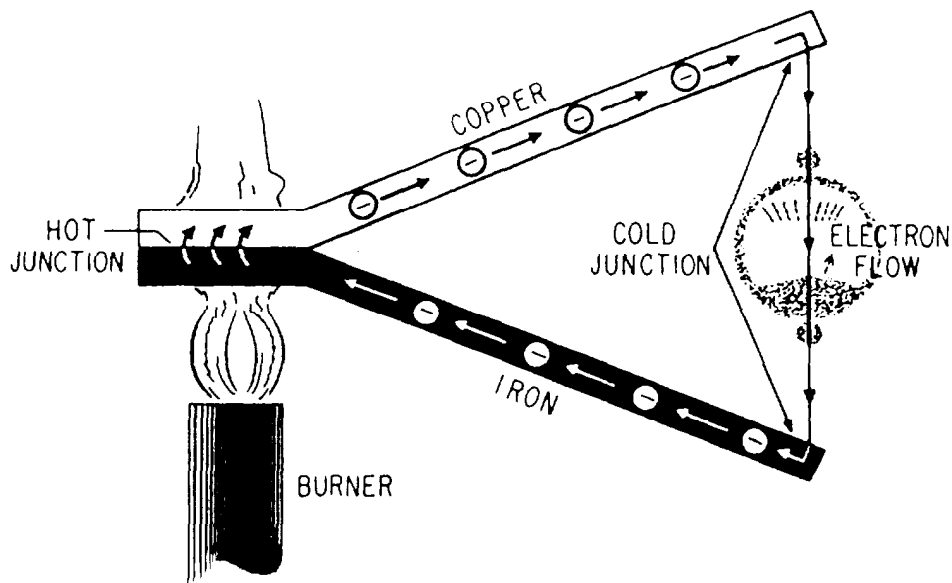

Figure 4-6.—Voltage produced by heat.

the hot and cold junctions. Consequently, they are widely used to measure temperature and as heat-sensing devices in automatic temperature control equipment. Thermocouples generally can be subjected to much greater temperatures than ordinary thermometers, such as the mercury or alcohol types.

**VOLTAGE PRODUCED BY LIGHT.—**

When light strikes the surface of a substance, it may dislodge electrons from their orbits around the surface atoms of the substance. This occurs because the light has energy, the same as any moving force.

Some substances, mostly metallic ones, are far more sensitive to light than others. That is, more electrons will be dislodged and emitted from the surface of a highly sensitive metal, with a given amount of light, than will be emitted from a less sensitive substance. Upon losing electrons, the photosensitive (light sensitive) metal becomes positively charged, and an electric force is created. Voltage produced in this manner is referred to as a photoelectric voltage.

The photosensitive materials most commonly used to produce a photoelectric voltage are various compounds of silver oxide or copper oxide. A complete device that operates on the photoelectric principle is referred to as a photoelectric cell. Many sizes and types of photoelectric cells are in use, each of which serves the special purpose for which it was designed. Nearly all, however, have some of the basic features of the photoelectric cells shown in figure 4-7.

The cell (fig. 4-7, view A) has a curved light-sensitive surface focused on the central anode. When light from the direction shown strikes the sensitive surface, it emits electrons toward the anode. The more intense the light, the greater is the number of electrons emitted. When a wire is connected between the filament and the back, or dark side, the accumulated electrons will flow to the dark side. These electrons will eventually pass through the metal of the reflector and replace the electrons leaving the light-sensitive surface. Thus, light energy is converted to a flow of electrons, and a usable current is developed.

The cell (fig. 4-7, view B) is constructed in layers. A base plate of pure copper is coated with light-sensitive copper oxide. An additional semitransparent layer of metal is placed over the

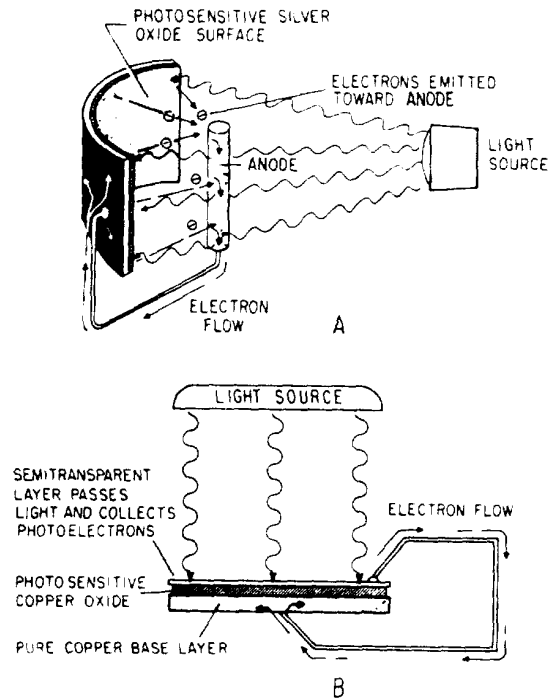

Figure 4-7.—Voltage produced by light.

copper oxide. This additional layer serves two purposes:

1. It is **EXTREMELY** thin to permit the penetration of light to the copper oxide.
2. It also accumulates the electrons emitted by the copper oxide.

An externally connected wire completes the electron path, the same as in the reflector type of cell. The photocell's voltage is used as needed by connection of the external wires to some other device, which amplifies (enlarges) it to a usable level.

A photocell's power capacity is very small. However, it reacts to light-intensity variations in a very short time. This characteristic makes the photocell very useful in detecting or accurately controlling a great number of processes or operations. For instance, the photoelectric cell, or some form of the photoelectric principle, is used in television cameras, automatic manufacturing process controls, door openers, burglar alarms, and so forth.

**VOLTAGE PRODUCED BY CHEMICAL ACTION .—** Up to this point, it has been shown

that electrons may be removed from their parent atoms and set in motion by energy derived from a source of magnetism, friction, pressure, heat, or light. In general, these forms of energy do not alter the molecules of the substance being acted upon. That is, molecules are not usually added, taken away, or split up when subjected to these four forms of energy. Only electrons are involved.

When the molecules of a substance are altered, the action is referred to as **CHEMICAL**. For instance, if the molecules of a substance combines with atoms of another substance, or gives up atoms of its own, the action is chemical in nature. Such action always changes the chemical name and characteristics of the substance affected. For instance, when atoms of oxygen from the air come in contact with bare iron, they merge with the molecules of iron. This iron is oxidized. It has changed chemically from iron to iron oxide, or rust. Its molecules have been altered by chemical action.

In some cases, when atoms are added to or taken away from the molecules of a substance, the chemical change will cause the substance to take on an electric charge. The process of producing a voltage by chemical action is used in batteries.

### Left-Hand Rule For Generators

In the preceding section we gave you a basic overview of voltage generation. This section will explain and demonstrate the left-hand rule for generators.

The left-hand rule for generators is a good representation of the relationships between motion, magnetic force, and resultant current in the generation of a voltage. By using this rule, you may find any of the three quantities if the other two are known. This rule is explained in the following manner.

Extend the thumb, forefinger, and middle finger of your left hand at right angles to one another, as shown in figure 4-8. Point your thumb in the direction the conductor is being moved. Point your forefinger in the direction of magnetic flux (from north to south). Your middle finger will then point in the direction of current flow in an external circuit to which the voltage is applied.

The more complex aspects of power generation by use of mechanical motion and magnetism are discussed indepth in module 5 of the NEETS series.

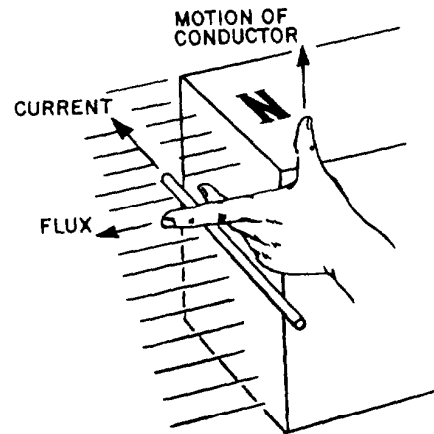

Figure 4-8.—Left-hand rule for generators.

## MECHANICAL THEORY

To understand basic mechanical theory, you must be familiar with the physics concepts used. In the following paragraphs we will discuss some of the laws and principles that will enable you to better understand these concepts.

### LAWS AND PRINCIPLES

In this section we will first define, and then explain, the basic laws and principles of mechanical theory.

- **CHARLES'S LAW:** If the pressure is constant, the volume of an enclosed dry gas varies directly with the absolute temperature.

- **BOYLE'S LAW:** The volume of an enclosed gas varies inversely with the applied pressure, provided the temperature remains constant.

- **NEWTON'S LAWS:** The first law states that a body at rest tends to remain at rest. A body in motion tends to remain in motion. The second law states that an imbalance of force on a body tends to produce an acceleration in the direction of the force. The acceleration, if any, is directly proportional to the force and inversely proportional to the mass of the body. Newton's third law states that for every action there is an equal and opposite reaction.

- **PASCAL'S LAW:** Pressure exerted at any point upon an enclosed liquid is transmitted undiminished in all directions.

- **BERNOULLI'S PRINCIPLE:** If an incompressible fluid flowing through a tube reaches a constriction, or narrowing of the tube, the velocity of fluid flowing through the constriction increases and the pressure decreases.

### Charles's Law

Jacques Charles, a French scientist, provided much of the foundation for the modern kinetic theory of gases. He found that, if the pressure is held constant, all gases expand and contract in direct proportion to the change in the absolute temperature. Any change in the temperature of a gas causes a corresponding change in volume. Therefore, if a given sample of a gas were heated while confined within a given volume, the pressure should increase. Actual experiments found that for each 1°C increase in temperature, the increase in pressure was about 1/273 of the pressure at 0°C. Thus, it is normal practice to state this relationship in terms of absolute temperature. In equation form, this part of the law becomes

$$P_1 T_2 = P_2 T_1,$$

where

P = pressure, and

T = temperature.

In words, this equation states that with a constant volume, the absolute pressure of an enclosed gas varies directly with the absolute temperature. Remember, when using this formula, you must convert stated pressures and temperatures to absolute values.

### Boyle's Law

Compressibility is an outstanding characteristic of gases. Robert Boyle, an English scientist, was among the first to study this characteristic. He called it the "springiness" of air. He discovered that when the temperature of an enclosed sample of gas was kept constant and the pressure doubled, the volume was reduced to half the former value. As the applied pressure was decreased, the resulting volume increased. From

these observations he concluded that for a constant temperature the product of the volume and pressure of an enclosed gas remains constant. This conclusion became Boyle's law.

You can demonstrate Boyle's law by confining a quantity of gas in a cylinder that has a tightly fitted piston. Apply force to the piston so as to compress the gas in the cylinder to some specific volume. If you double the force applied to the piston, the gas will compress to one half its original volume (fig. 4-9).

Changes in the pressure of a gas also affect the density. As the pressure increases, its volume decreases; however, there is no change in the weight of the gas. Therefore, the weight per unit volume (density) increases. So it follows that the density of a gas varies directly with the pressure if the temperature is constant.

### Newton's Laws

Sir Isaac Newton was an English philosopher and mathematician who lived from 1642 to 1727 A.D. He was the formulator of the basic laws of modern philosophy concerning gravity and motion.

**NEWTON'S FIRST LAW.**—Newton's first law states that a body at rest tends to remain at rest. A body in motion tends to remain in motion. This law can be demonstrated easily in everyday use. For example, a parked automobile will remain motionless until some force causes it to move—a body at rest tends to remain at rest. The second portion of the law—a body in motion tends to remain in motion—can be demonstrated only in a theoretical sense. The same car placed in motion would remain in

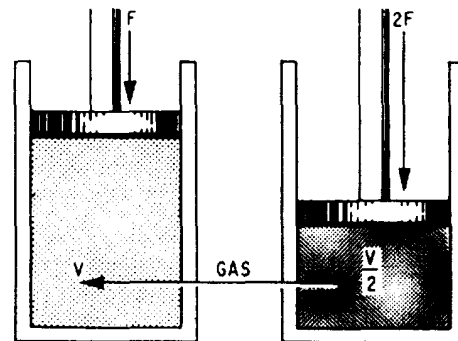

Figure 4-9.—Gas compressed to half its original volume by a double force.



motion (1) if all air resistance were removed, (2) if no friction were in the bearings, and (3) if the surface were perfectly level.

**NEWTON'S SECOND LAW.**—Newton's second law states that an imbalance of force on a body tends to produce an acceleration in the direction of the force. The acceleration, if any, is directly proportional to the force. It is inversely proportional to the mass of the body. This law can be explained by throwing a common softball. The force required to accelerate the ball to a rate of  $50 \text{ ft/sec}^2$  would have to be doubled to obtain an acceleration rate of  $100 \text{ ft/sec}^2$ . However, if the mass of the ball were doubled, the original acceleration rate would be cut in half. You would have  $50 \text{ ft/sec}^2$  reduced to  $25 \text{ ft/sec}^2$ .

**NEWTON'S THIRD LAW.**—Newton's third law states that for every action there is an equal and opposite reaction. You have demonstrated this law if you have ever jumped from a boat up to a dock or a beach. The boat moved opposite to the direction you jumped. The recoil from firing a shotgun is another example of action-reaction. Figure 4-10 depicts these examples.

In an airplane, the greater the mass of air handled by the engine, the more it is accelerated by the engine. The force built up to thrust the plane forward is also greater. In a gas turbine, the thrust velocity can be absorbed by the turbine rotor and converted to mechanical energy. This is done by adding more and progressively larger power turbine wheels.

### Pascal's Law

Blaise Pascal was a French philosopher and mathematician who lived from 1623 to 1662 A.D. His work, simply stated, could be interpreted as pressure exerted at any point upon an enclosed liquid is transmitted undiminished in all directions.

Pascal's law governs the BEHAVIOR of the static factors concerning noncompressible fluids when taken by themselves.

### Bernoulli's Principle

Jacques (or Jakob) Bernoulli was a Swiss philosopher and mathematician who lived from 1654 to 1705 A.D. He worked extensively with hydraulics and the pressure-temperature relationship. Bernoulli's principle governs the RELATIONSHIP of the static and dynamic

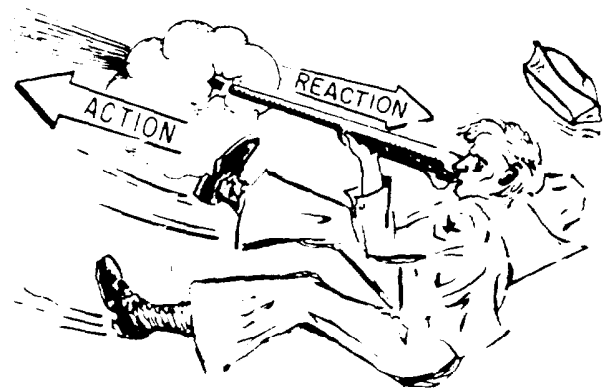
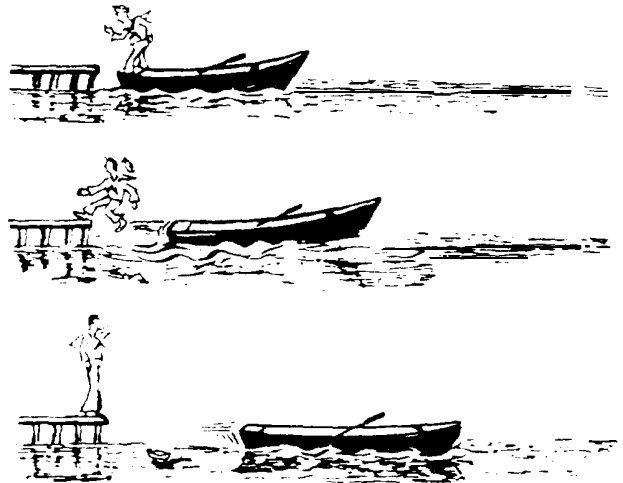

Figure 4-10.—Newton's third law of motion.

factors concerning noncompressible fluids. Consider the system shown in figure 4-11. Chamber A is under pressure and is connected by a tube to chamber B, which is also under pressure. Chamber A is under static pressure of 100 psi. The pressure at some point, X, along the connecting tube consists of a velocity pressure of 10 psi. This is exerted in a direction parallel to the line of flow. Added is the unused static pressure of 90 psi, which obeys Pascal's law and operates equally in all directions. As the fluid enters chamber B from the constricted space, it is slowed down. In so doing, its velocity head is changed back to pressure head. The force required to absorb the fluid's inertia equals the force required to start the fluid moving originally. Therefore, the static pressure in chamber B is again equal to that in chamber A. It was lower at intermediate point X.

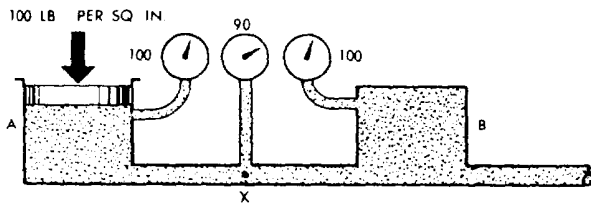

Figure 4-11.—Relationship of static and dynamic factors—Bernoulli's principle.

Figure 4-11 disregards friction and it is not encountered in actual practice. Force or head is also required to overcome friction. But, unlike inertia effect, this force cannot be recovered again although the energy represented still exists somewhere as heat. Therefore, in an actual system the pressure in chamber B would be less than in chamber A. This is a result of the amount of pressure used in overcoming friction along the way.

At all points in a system the static pressure is always the original static pressure LESS any velocity head at the point in question. It is also LESS the friction head consumed in reaching that point. Both velocity head and friction represent energy that came from the original static head. Energy cannot be destroyed. So, the sum of the static head, velocity head, and friction at any point in the system must add up to the original static head. This, then, is Bernoulli's principle; more simply stated, if a noncompressible fluid flowing through a tube reaches a constriction, or narrowing of the tube, the velocity of fluid flowing through the constriction increases, and the pressure decreases.

## ENERGY

Can you define energy? Although everyone has a general idea of the meaning of energy, a good definition is hard to find. Most commonly, perhaps, energy is defined as the capacity for doing work. This is not a very complete definition. Energy can produce other effects which cannot possibly be considered work. For example, heat can flow from one object to another without doing work; yet heat is a form of energy, and the process of heat transfer is a process that produces an effect.

A better definition of energy, therefore, states that energy is the capacity for producing an effect.

Energy exists in many forms. For convenience, we usually classify energy according to the size and nature of the bodies or particles with which it is associated. Thus we say that MECHANICAL ENERGY is the energy associated with large bodies or objects—usually, things that are big enough to see. THERMAL ENERGY is energy associated with molecules. Chemical energy is energy that arises from the forces that bind the atoms together in a molecule. Chemical energy is demonstrated whenever combustion or any other chemical reaction takes place. Electrical energy, light, X rays, and radio waves are examples of energy associated with particles that are even smaller than atoms.

Each of these types of energy (mechanical energy, thermal energy, and so forth) must also be classified as being either stored energy or energy in transition.

STORED ENERGY can be thought of as energy that is actually contained in or stored in a substance or system. There are two kinds of stored energy: (1) potential energy and (2) kinetic energy. When energy is stored in a substance or system because of the relative POSITIONS of two or more objects or particles, we call it potential energy. When energy is stored in a substance or system because of the relative VELOCITIES of two or more objects or particles, we call it kinetic energy.

If you do not completely understand this classification, come back to it from time to time as you read the following sections on mechanical energy and thermal energy. The examples and discussion given in the following sections will probably help you understand this classification.

## Mechanical Energy

Let's consider the two stored forms of mechanical energy. Mechanical POTENTIAL energy exists because of the relative positions of two or more objects. For example, a rock resting on the edge of a cliff in such a position that it will fall freely if pushed has mechanical potential energy. Water at the top of a dam has mechanical potential energy. A sled that is being held at the top of an icy hill has mechanical potential energy.

Mechanical KINETIC energy exists because of the relative velocities of two or more objects. If you push that rock, open the gate of the dam, or let go of the sled, something will move. The rock will fall; the water will flow; the sled will slide down the hill. In each case the mechanical

potential energy will be changed to mechanical kinetic energy. Another way of saying this is that the energy of position will be changed to the energy of motion.

In these examples, you will notice that an external source of energy is used to get things started. Energy from some outside source is required to push the rock, open the gate of the dam, or let go of the sled. All real machines and processes require this kind of boost from an energy source outside the system. For example, there is a tremendous amount of chemical energy stored in fuel oil; but this energy will not turn the power turbine until you have expended some energy to start the oil burning. Similarly, the energy in any one system affects other energy systems. However, it is easier to learn the basic principles of energy if we forget about all the energy systems that might be involved in or affected by each energy process. In the examples given in this chapter, therefore, we will consider only one energy process or energy system at a time, disregarding both the energy boosts that may be received from outside systems and the energy transfers that may take place between the system we are considering and other systems.

Notice that both mechanical potential energy and mechanical kinetic energy are stored forms of energy. It is easy to see why we regard mechanical potential energy as being stored, but it is not so easy to see the same thing about mechanical kinetic energy. Part of the trouble comes about because mechanical kinetic energy is often referred to as the energy of motion, thus leading to the false conclusion that energy in transition is somehow involved. This is not the case, however. Work is the only form of mechanical energy that can be properly considered as energy in transition.

If you have trouble with the idea that mechanical kinetic energy is stored, rather than in transition, think of it like this: A bullet that has been fired from a gun has mechanical kinetic energy because it is in motion. The faster the bullet is moving, the more kinetic energy it has. There is no doubt in anybody's mind that the bullet has the capacity to produce an effect, so we may safely say that it has energy. Although the bullet is not in transition, the energy of the bullet is not transferred to any other object or system until the bullet strikes some object that resists its passage. When the bullet strikes against a resisting object, then, and only then, can we say that energy in transition exists, in the form of heat and work.

In this example, we are ignoring the fact that some work is done against the resistance of the air and that some heat results from the passage of the bullet through the air. But this does not change the basic idea that kinetic energy is stored energy rather than energy in transition. The air must be regarded as a resisting object, which causes some of the stored kinetic energy of the bullet to be converted into energy in transition (heat and work) while the bullet is passing through the air. However, the major part of the stored kinetic energy does not become energy in transition until the bullet strikes an object firmer than air which resists its passage.

Mechanical potential energy is measured in foot-pounds. Consider, for example, the rock at the top of the cliff. If the rock weighs 5 pounds and if the distance from the rock to the earth at the base of the cliff is 100 feet, 500 foot-pounds of mechanical potential energy exist because of the relative positions of the rock and the earth. Another way of expressing this idea is by the formula

$$PE = W \times D,$$

where

PE = total potential energy of the object (in foot-pounds),

W = total weight of the object (in pounds),  
and

D = distance between the earth and the object (in feet).

Mechanical kinetic energy is also measured in foot-pounds. The amount of kinetic energy present at any one time is directly related to the velocity of the moving object and to the weight of the moving object.

Mechanical potential energy can be changed into mechanical kinetic energy. If you push that 5-pound rock over the edge of the 100-foot cliff, it begins to fall, and as it falls, it loses potential energy and gains kinetic energy. At any given moment, the total amount of mechanical energy (potential plus kinetic) stored in the system is the same—that is, 500 foot-pounds. But the proportions of potential energy and kinetic energy are changing all the time as the rock is falling. Just before the rock hits the earth, all the stored mechanical energy is kinetic energy. As the rock hits the earth, the kinetic energy is changed into energy in transition—that is, work and heat.

Mechanical kinetic energy can likewise be changed into mechanical potential energy. For example, suppose you throw a baseball straight up in the air. The ball has kinetic energy while it is in motion, but the amount of kinetic energy decreases and the amount of potential energy increases as the ball travels upward. When the ball has reached its uppermost position, just before it starts its fall back to earth, it has only potential energy. Then, as it falls back toward the earth, the potential energy is changed into kinetic energy again.

Mechanical energy in transition is called WORK. When an object is moved through a distance against a resisting force, we say that work has been done. The formula for calculating work is

$$W = F \times D,$$

where

W = work,

F = force, and

D = distance.

As you can see from this formula, you need to know how much force is exerted and the distance through which the force acts before you can find how much work is done. The unit of force is the pound. When work is done against gravity, the force required to move an object is equal to the weight of the object. Why? Because weight is a measure of the force of gravity or, in other words, a measure of the force of attraction between an object and the earth. How much work will you do if you lift that 5-pound rock from the bottom of the 100-foot cliff to the top? You will do 500 foot-pounds of work—the weight of the object (5 pounds) times the distance (100 feet) that you move it against gravity.

We also do work against forces other than the force of gravity. When you push an object across the deck, you are doing work against friction. In this case, the force you work against is not only the weight of the object, but also the force required to overcome friction and slide the object over the surface of the deck.

Notice that mechanical potential energy, mechanical kinetic energy, and work are all measured in the same unit, foot-pounds. One foot-pound of work is done when a force of 1 pound acts through a distance of 1 foot. One foot-pound of mechanical potential energy or mechanical kinetic energy is the amount of energy that is required to accomplish 1 foot-pound of work.

The amount of work done has nothing at all to do with how long it takes to do it. When you lift a weight of 1 pound through a distance of 1 foot, you have done one foot-pound of work, regardless of whether you do it in half a second or half an hour. The rate at which work is done is called POWER. The common unit of measurement for power is the HORSEPOWER (hp). By definition, 1 horsepower is equal to 33,000 foot-pounds of work per minute or 550 foot-pounds of work per second. Thus a machine that is capable of doing 550 foot-pounds of work per second is said to be a 1 horsepower machine. (As you can see, your horsepower rating would not be very impressive if you did 1 foot-pound of work in half an hour. Figure it out. It works out to be just a little more than one-millionth of a horsepower.)

### Thermal Energy

All substances are composed of very small particles called molecules. The energy associated with molecules is called thermal energy. Thermal energy, like mechanical energy, exists in two stored forms and in one transitional form. The two stored forms of thermal energy are called (1) internal potential energy, and (2) internal kinetic energy. Thermal energy in transition is called HEAT.

Although molecules are too small to be seen, they behave in some ways pretty much like the larger objects we considered in the discussion of mechanical energy. Molecules have energy of position (internal potential energy) because of the forces which attract molecules to each other. In this way, they are somewhat like the rock and the earth we considered before. Molecules have energy of motion (internal kinetic energy) because they are constantly in motion. Thus, the two stored forms of thermal energy—internal potential energy and internal kinetic energy—are in some ways similar to mechanical potential energy and mechanical kinetic energy, except that everything is on a smaller scale.

For most purposes, we will not need to distinguish between the two stored forms of thermal energy. Therefore, instead of referring to internal potential energy and internal kinetic energy, from now on we will simply use the term *internal energy*. By internal energy, then, we will mean the sum total of all internal energy stored in the substance or system because of the motion of the molecules and because of the forces of attraction between molecules. Although the term

may be unfamiliar to you, you probably know more about internal energy than you realize. Because molecules are constantly in motion, they exert a pressure on the walls of the pipe, cylinder, or other object in which they are contained. Also, the temperature of any substance arises from, and is directly proportional to, the activity of the molecules. Therefore, every time you read thermometers and pressure gauges you are finding out something about the amount of internal energy contained in the substance. High pressures and temperatures indicate that the molecules are moving rapidly and that the substance therefore has a lot of internal energy.

HEAT is a more familiar term than internal energy, but may actually be more difficult to define correctly. The important thing to remember is that heat is THERMAL ENERGY IN TRANSITION—that is, it is thermal energy that is moving from one substance or system to another.

An example will help to show the difference between heat and internal energy. Suppose there are two equal lengths of pipe made of identical materials and containing steam at the same pressure and temperature. One pipe is well insulated; the other is not insulated at all. From everyday experience you know that more heat will flow from the uninsulated pipe than from the insulated pipe. When the two pipes are first filled with steam, the steam in one pipe contains exactly as much internal energy as the steam in the other pipe. We know this is true because the two pipes contain equal volumes of steam at the same pressure and at the same temperature. After a few minutes, the steam in the uninsulated pipe will contain much less internal energy than the steam in the insulated pipe, as we can tell by measuring the pressure and the temperature of the steam in each pipe. What has happened? Stored thermal energy—internal energy—has moved from one system to another, first from the steam to the pipe, then from the uninsulated pipe to the air. This MOVEMENT or FLOW of thermal energy from one system to another is called heat.

A good deal of confusion exists concerning the use of the word *heat*. For example, you will hear people say that a hot object contains a lot of heat when they really mean that it contains a lot of internal energy. Or you will hear that heat is added to, or removed from a substance. Since heat is the FLOW of thermal energy, it can no more be added to a substance than the flow of water could be added to a river. (You might add water, and this addition might increase the

flow; but you could hardly say that you added flow.) The only kind of thermal energy that can in any sense be added to or removed from a substance is INTERNAL ENERGY.

The distinction between heat and internal energy must be clear in your own mind before you can understand the basic principles of a gas turbine plant.

## Energy Transformations

The machinery and equipment in the engineering plant aboard ship are designed either to carry energy from one place to another or to change a substance from one form to another. The principles of energy transformations and some of the important energy changes that occur in the shipboard propulsion cycle are discussed in the following paragraphs.

**CONSERVATION OF ENERGY.**—The basic principle dealing with the transformation of energy is the PRINCIPLE OF THE CONSERVATION OF ENERGY. This principle can be stated in several ways. Most commonly, perhaps, it is stated that energy can be neither destroyed nor created, but only transformed. Another way to state this principle is that the total quantity of energy in the universe is always the same. Still another way of expressing this principle is the equation, Energy in = Energy out.

The energy out may be quite different in form from the energy in, but the total amount of energy input must always equal the total amount of energy output.

Another principle, the PRINCIPLE OF THE CONSERVATION OF MATTER, states that matter can be neither created nor destroyed, but only transformed. As you probably know the development of the atom bomb demonstrated that matter can be converted into energy; other developments have demonstrated that energy can be converted into matter. Therefore, the principle of the conservation of energy and the principle of the conservation of matter are no longer considered as two parts of a single law or principle but are combined into one principle. That principle states that matter and energy are interchangeable, and the total amount of energy and matter in the universe is constant.

The interchangeability of matter and energy is mentioned here only to point out that the statement energy in must equal energy out is not strictly true for certain situations. However, any noticeable conversion of matter into energy or

energy into matter can occur only under very special conditions, which we need not consider now. All the energy transformations that we will deal with can be understood quite simply if we consider only the principle of the conservation of energy—that is, ENERGY IN MUST EQUAL ENERGY OUT.

**TRANSFORMING HEAT TO WORK.—**

The energy transformation of primary interest in the shipboard gas turbine plant is the transformation from heat to work. To see how this transformation occurs, we need to consider the pressure, temperature, and volume relationships which hold true for gases. These relationships may be summarized as follows:

- When the temperature is held constant, increasing the pressure on a gas causes a proportional decrease in volume. Decreasing the pressure causes a proportional increase in volume.
- When the pressure is held constant, increasing the temperature of a gas causes a proportional increase in volume. Decreasing the temperature causes a proportional decrease in volume.
- When the volume is held constant, increasing the temperature of a gas causes a proportional increase in pressure. Decreasing the temperature causes a proportional decrease in pressure.

**LEVERS/LEVERAGE**

The LEVER is one of the six types of simple machines. The others are the BLOCK, the WHEEL AND AXLE, the INCLINED PLANE, the SCREW, and the GEAR. Physicists recognize only two basic “principles” in machines; namely, the lever and the inclined plane. The block, the wheel and axle, and the gear may be considered levers. The wedge and the screw use the principle of the inclined plane. In this section we will discuss levers and leverage only.

The simplest machine, and perhaps the one with which you are most familiar, is the LEVER. A seesaw is a familiar example of a lever in which one weight balances the other. There are three basic parts which you will find in all levers; namely, the FULCRUM, a force or EFFORT, and a RESISTANCE. The mechanical advantage gained by using a lever is called LEVERAGE.

Look at the lever in figure 4-12. You see the pivotal point F (fulcrum); the effort (E), which you apply at a distance (A) from the fulcrum; and a resistance (R), which acts at a distance (a) from the fulcrum. Distances A and a are the lever arms. Figure 4-13 shows the three classes of levers. The location of the fulcrum (the fixed or pivot point) with relation to the resistance (or weight) and the effort determines the lever class.

**FIRST-CLASS LEVERS**

In the first-class lever (fig. 4-13, view A), the fulcrum is located between the effort and the resistance. As mentioned earlier, the seesaw is a good example of the first-class lever. The amount of weight and the distance from the fulcrum can be varied to suit the need. Another good example is the oars in a rowboat. Notice that the sailor in

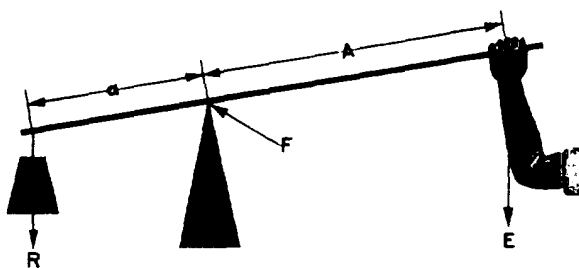

Figure 4-12.—A simple lever.

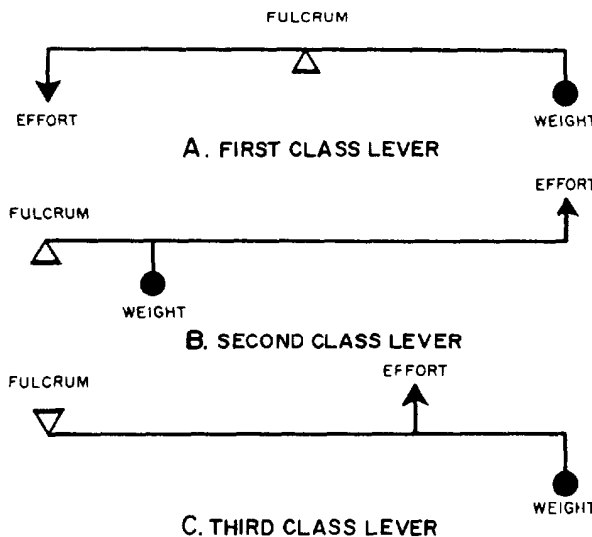

Figure 4-13.—Three classes of levers.

figure 4-14 applies his effort on the handles of the oars. The oarlock acts as the fulcrum, and the water acts as the resistance to be overcome. In this case, as in figure 4-12, the force is applied on one side of the fulcrum and the resistance to be overcome is applied to the opposite side, hence this is a first-class lever. Crowbars, shears, and pliers are common examples of this class of lever.

## SECOND-CLASS LEVERS

The second-class lever (fig. 4-13, view B) has the fulcrum at one end; the effort is applied at the other end. The resistance is somewhere between these points. The wheelbarrow in figure 4-15 is a good example of a second-class lever. If you apply 50 pounds of effort to the handles of a wheelbarrow 4 feet from the fulcrum (wheel), you can lift 200 pounds of weight 1 foot from the fulcrum. If the load were placed further

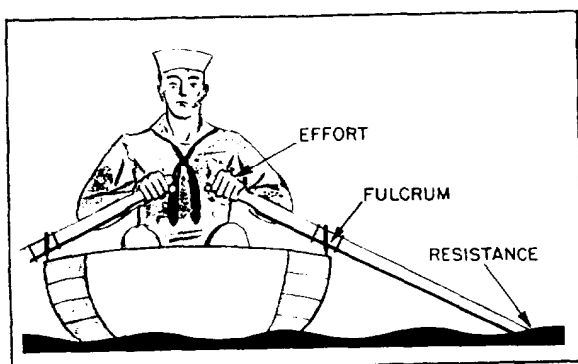

Figure 4-14.—Oars are levers.

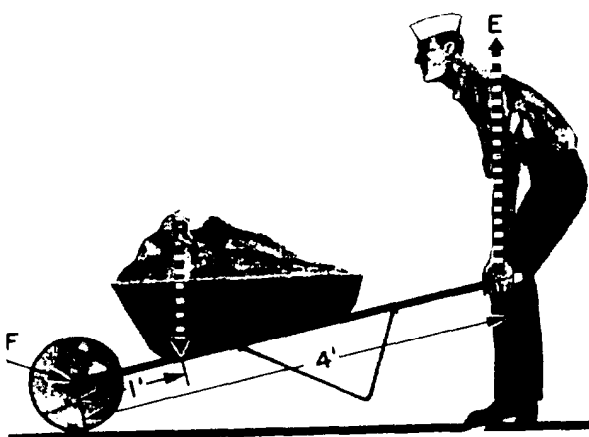

Figure 4-15.—This makes it easier.

back away from the wheel, would it be easier or harder to lift?

Both first- and second-class levers are commonly used to help in overcoming big resistances with a relatively small effort.

## THIRD-CLASS LEVERS

Occasionally you will want to speed up the movement of the resistance even though you have to use a large amount of effort. Levers that help you accomplish this are third-class levers. As shown in figure 4-13, view C, the fulcrum is at one end of the lever and the weight or resistance to be overcome is at the other end, with the effort applied at some point between. You can always spot third-class levers because you will find the effort applied between the fulcrum and the resistance. Look at figure 4-16. It is easy to see that while point E is moving the short distance (e), the resistance (R) has been moved a greater distance (r). The speed of R must have been greater than that of E since R covered a greater distance in the same length of time.

Your arm (fig. 4-17) is a third-class lever. It is this lever action that makes it possible for you to flex your arms so quickly. Your elbow is the fulcrum. Your biceps muscle, which ties into your forearm about an inch below the elbow, applies the effort; and your hand is the resistance, located some 18 inches from the fulcrum. In the split second it takes your biceps muscle to contract an inch, your hand has moved through an 18-inch arc. You know from experience that it takes a big pull at E to overcome a relatively small resistance at R. Just to remind yourself of this principle, try closing a door by pushing on it about 3 or 4 inches from the hinges (fulcrum). The moral is, you don't use third-class levers to do heavy jobs, you use them to gain speed.

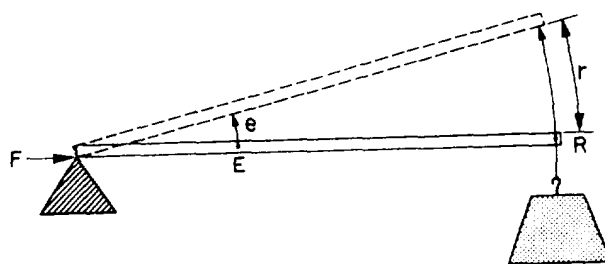

Figure 4-16.—A third-class lever.

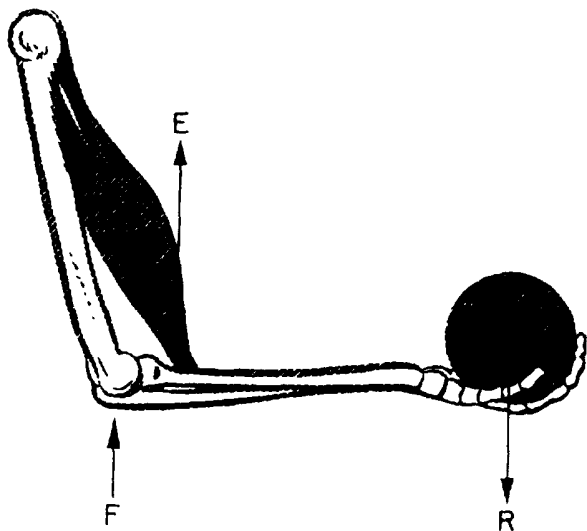

Figure 4-17.—Your arm is a lever.

## MEASUREMENT OF TEMPERATURE

Temperature is measured by bringing a measuring system (such as a thermometer) into contact with the system to be measured. You will often need to know the expansion of a liquid, the pressure of a gas, emf, electrical resistance, or some other mechanical, electrical, or optical property that has a definite and known relationship to temperature.

The measurement of a property other than temperature can take us only so far in the measuring of temperature. In noting changes in temperature, we must be able to assign a numerical value to any given temperature. For this we need temperature scales. The two most familiar temperature scales are the Celsius scale and the Fahrenheit scale.

The Celsius scale is often called the centigrade scale in the United States and Great Britain. By international agreement, however, the name was changed from centigrade to Celsius in honor of the eighteenth-century Swedish astronomer, Anders Celsius. The symbol for a degree on this scale (no matter whether it is called Celsius or centigrade) is °C. The Celsius scale takes 0°C as the freezing point and 100°C as the boiling point of pure water at standard sea level atmospheric pressure. The Fahrenheit scale takes 32°F as the freezing point and 212°F as the boiling point of pure water at standard sea level atmospheric pressure. The interval between the freezing point

and the boiling point is divided into 100 degrees on the Celsius scale and divided into 180 degrees on the Fahrenheit scale.

Since the actual value of the interval between the freezing point and the boiling point is identical, the numerical readings on Celsius and Fahrenheit thermometers have no absolute significance and the size of the degree is arbitrarily chosen for each scale. The relationship between degrees Celsius and degrees Fahrenheit is given by the formulas

$$^{\circ}\text{F} = \left(\frac{9}{5}\text{^{\circ}\text{C}}\right) + 32$$

and

$$\text{^{\circ}\text{C}} = \frac{5}{9} (\text{^{\circ}\text{F}} - 32).$$

Many people have trouble remembering these formulas, with the result that they either get them mixed up or have to look them up in a book every time a conversion is necessary. If you concentrate on trying to remember the basic relationships given by these formulas, you may find it easier to make conversions. The essential points to remember are these:

1. Celsius degrees are larger than Fahrenheit degrees. One Celsius degree is equal to 1.8 Fahrenheit degrees, and each Fahrenheit degree is only 5/9 of a Celsius degree.
2. The zero point on the Celsius scale represents exactly the same temperature as the 32-degree point on the Fahrenheit scale.
3. The temperatures 100°C and 212°F are identical.

In some scientific and engineering work, particularly where heat calculations are involved, an absolute temperature scale is used. The zero point on an absolute temperature scale is the point called ABSOLUTE ZERO. Absolute zero is determined theoretically, rather than by actual measurement. Since the pressure of a gas at constant volume is directly proportional to the temperature, we assume that the pressure of a gas is a valid measure of its temperature. On this assumption, the lowest possible temperature (absolute zero) is defined as the temperature at which the pressure of a gas would be zero.

Two absolute temperature scales have been in use for many years. The Rankine absolute scale is an extension of the Fahrenheit scale; it is sometimes called the Fahrenheit absolute scale.



Degrees on the Rankine scale are the same size as degrees on the Fahrenheit scale, but the zero point on the Rankine scale is at  $-459.67^{\circ}$  Fahrenheit. In other words, absolute zero is zero on the Rankine scale and  $-459.67^{\circ}$  on the Fahrenheit scale.

A second absolute scale, the Kelvin, is more widely used than the Rankine. The Kelvin scale was originally conceived as an extension of the Celsius scale, with degrees of the same size but with the zero point shifted to absolute zero. Absolute zero on the Celsius scale is  $-273.15^{\circ}$ .

In 1954, a new international absolute scale was developed. The new scale was based upon one fixed point, rather than two. The one fixed point was the triple point of water—that is, the point at which all three phases of water (solid, liquid, and vapor) can exist together in equilibrium. The

triple point of water, which is  $0.01^{\circ}\text{C}$  above the freezing point of water, was chosen because it can be reproduced with much greater accuracy than either the freezing point or the boiling point. On this new scale, the triple point was given the value 273.16 K. Note that neither the word *degrees* nor the symbol  $^{\circ}$  is used; instead, the units are referred to as Kelvin and the symbol K is used rather than the symbol  $^{\circ}\text{K}$ .

In 1960 the triple point of water was finally adopted as the fundamental reference for this temperature scale. The scale now in use is the international Practical Temperature Scale of 1968 (ITS-68). However, you often see this scale referred to as the Kelvin scale.

Although the triple point of water is considered the basic or fundamental reference for the ITS-68, five other fixed points are used to

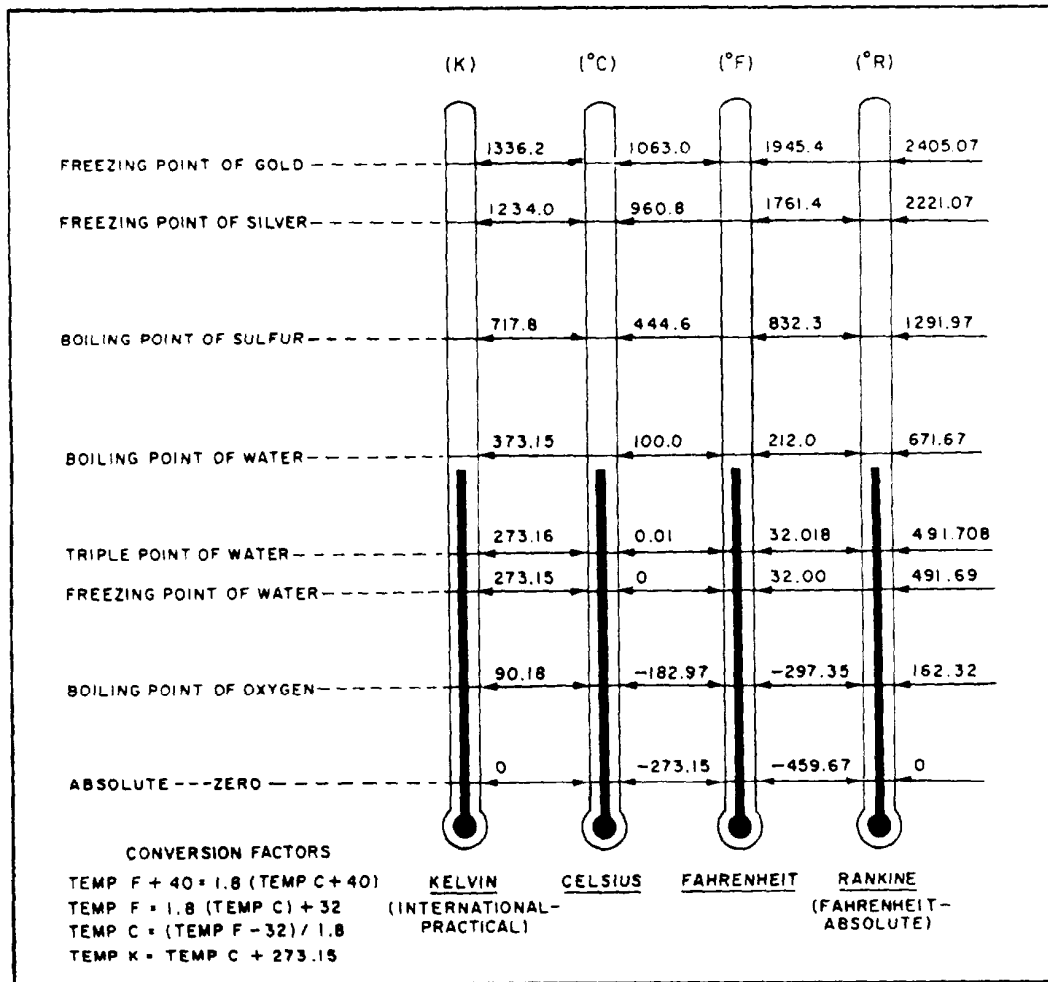

Figure 4-18.—Comparison of Kelvin, Celsius, Fahrenheit, and Rankine temperatures.

help define the scale. These are the freezing point of gold, the freezing point of silver, the boiling point of sulfur, the boiling point of water, and the boiling point of oxygen.

Figure 4-18 is a comparison of the Kelvin, Celsius, Fahrenheit, and Rankine temperatures. All of the temperature points listed above absolute zero are considered as fixed points on the Kelvin scale except for the freezing point of water. The other scales are based on the freezing and boiling points of water.

### PRESSURE DEFINITIONS

Pressure like temperature is one of the basic engineering measurements and one that must be frequently monitored aboard ship. As with temperature readings, pressure readings provide you with an indication of the operating condition of equipment. Pressure is defined as the force per unit area.

The simplest pressure units are the ones that indicate how much force is applied to an area of a certain size. These units include pounds per square inch, pounds per square foot, ounces per square inch, newtons per square millimeter, and dynes per square centimeter, depending upon the system you use.

You also use another kind of pressure unit that involves length. These units include inches of water, inches of mercury (Hg), and inches of some other liquid of a known density. Actually, these units do not involve length as a fundamental dimension. Rather, length is taken as a measure of force or weight. For example, a reading of 1 inch of water (1 in. H<sub>2</sub>O) means that the exerted pressure is able to support a column of water 1 inch high, or that a column of water in a U-tube would be displaced 1 inch by the pressure being measured. Similarly, a reading of 12 inches of mercury (12 in.Hg) means that the measured pressure is sufficient to support a column of mercury 12 inches high. What is really being expressed (even though it is not mentioned in the pressure unit) is that a certain quantity of material (water, mercury, and so on) of known density exerts a certain definite force upon a specified area. Pressure is still force per unit area, even if the pressure unit refers to inches of some liquid.

In interpreting pressure measurements, a great deal of confusion arises because the zero point on most pressure gauges represents atmospheric pressure rather than zero absolute pressure. Thus it is often necessary to specify the kind

of pressure being measured under any given conditions. To clarify the numerous meanings of the word *pressure*, the relationships among gauge, atmospheric, vacuum, and absolute pressures, are shown in figure 4-19.

**GAUGE PRESSURE** is the pressure actually shown on the dial of a gauge that registers pressure relative to atmospheric pressure. An ordinary pressure gauge reading of zero does not mean that there is no pressure in the absolute sense; rather, it means that there is no pressure in excess of atmospheric pressure.

**ATMOSPHERIC PRESSURE** is the pressure exerted by the weight of the atmosphere. At sea level, the average pressure of the atmosphere is sufficient to hold a column of mercury at the height of 76 centimeters or 29.92 inches. Since a column of mercury 1 inch high exerts a pressure of 0.49 pound per square inch at its base, a column of mercury 29.92 inches high exerts a pressure that is equal to  $29.92 \times 0.49$  or about 14.7 psi. Since we are dealing now in absolute pressure, we say that the average atmospheric pressure at sea level is 14.7 pounds per square inch absolute (psia). It is zero on the ordinary pressure gauge.

Notice, however, that the figure of 14.7 psia represents the average atmospheric pressure at sea level; it does not always represent the actual pressure being exerted by the atmosphere at the moment that a gauge is being read.

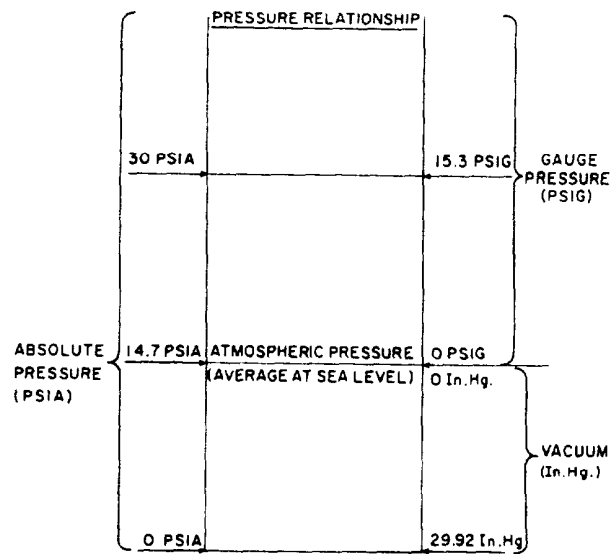

Figure 4-19.—Relationships among gauge pressure, atmospheric pressure, vacuum, and absolute pressure.

BAROMETRIC PRESSURE is the term used to describe the actual atmospheric pressure that exists at any given moment. Barometric pressure may be measured by a simple mercury column or by a specially designed instrument called an aneroid barometer.

A space in which the pressure is less than atmospheric pressure is said to be under partial vacuum. The amount of vacuum is expressed in terms of the difference between the absolute pressure in the space and the pressure of the atmosphere. Most commonly, vacuum is expressed in inches of mercury, with the vacuum gauge scale marked from 0 to 30 in.Hg. When a vacuum gauge reads zero, the pressure in the space is the same as atmospheric pressure—or, in other words, there is no vacuum. A vacuum gauge reading of 29.92 in.Hg would indicate a perfect (or nearly perfect) vacuum. In actual practice, it is impossible to obtain a perfect vacuum even under laboratory conditions. A reading between 0 and 29.92 in.Hg is a partial vacuum.

ABSOLUTE PRESSURE is atmospheric pressure plus gauge pressure or minus vacuum. For example, a gauge pressure of 300 psig equals an absolute pressure of 314.7 psia (300 + 14.7). Or, for example, consider a space in which the measured vacuum is 10 in.Hg; the absolute pressure in this space is figured by subtracting the measured vacuum (10 in.Hg) from the nearly perfect vacuum (29.92 in.Hg). The absolute pressure then will be 19.92 or approximately 20 in.Hg absolute. It is important to note that the amount of pressure in a space under vacuum can only be expressed in terms of absolute pressure.

You may have noticed that sometimes we use the letters psig to indicate gauge pressure and other times we merely use psi. By common convention, gauge pressure is always assumed

when pressure is given in pounds per square inch, pounds per square foot, or similar units. The g (for gauge) is added only when there is some possibility of confusion. Absolute pressure, on the other hand, is always expressed as pounds per square inch absolute (psia), pounds per square foot absolute (psfa), and so forth. It is always necessary to establish clearly just what kind of pressure we are talking about, unless this is very clear from the nature of the discussion.

To this point, we have considered only the most basic and most common units of measurement. It is important to remember that hundreds of other units can be derived from these units; remember also that specialized fields require specialized units of measurement. Additional units of measurement are introduced in appropriate places throughout the remainder of this training manual. When you have more complicated units of measurement, you may find it helpful to first review the basic information given here.

## SUMMARY

We have discussed the basic laws and principles covering electrical and mechanical theory. This chapter was provided to give you only a basis on which to expand your knowledge of electrical and mechanical fundamentals. It is important that you have a sound understanding of these laws and principles. The complex electrical systems and the internal pressure-temperature relationships in a simple GTE make it imperative that you understand the material presented. If you have problems understanding this material, you should reread the pertinent portions until you have absorbed the basic concepts.

## CHAPTER 5

# INDICATING INSTRUMENTS

Constantly used throughout this text is the word *monitor*. As used in this text, monitor means to observe, record, or detect an operation or condition using instruments. As a GSE3/GSM3, your most important job aboard ship is to monitor. As a watch stander, you observe and detect malfunctions in the operating equipment and take the necessary action to prevent damage to the equipment. For accuracy, the best method of observing and detecting a malfunction in equipment is through use of indicating instruments, such as temperature and pressure gauges. These gauges range from direct acting, such as ordinary thermometers, to electrically activated resistance detectors. The main function of all indicating instruments is to give information on the operating condition of the equipment. When you are operating equipment, these instruments give you the ability to compare normal operating conditions or preset limits to the actual operating conditions. This comparison permits you to detect an abnormal condition before it causes major damage to the equipment. An example of this is a main reduction gear (MRG) bearing failure. As a watch stander, by taking your hourly readings from the bearing thermometer, you would notice a rise in temperature from hour to hour; you would be able to inform your supervisor of a suspected problem. If a sudden failure occurs, such as loss of lube oil to the bearing, the sudden rise in temperature would activate a remote alarm when it reached a preset point. The alarm would alert personnel in the engine room and the EOOW station. This would allow the watch to institute casualty control procedures to minimize the damage. We used this example to emphasize to you the importance of indicating instruments to shipboard operation.

In this chapter we describe the various types of indicating instruments that you, as a GSE3/GSM3, will come in contact with while operating and maintaining gas turbine propulsion systems. These include temperature, pressure, level, and remote indicators. Upon completion of

this chapter, you should be able to describe the types of temperature and pressure measuring instruments, liquid level indicators, electrical indicating instruments, and miscellaneous sensors used in the control and monitoring of GTEs and auxiliary and support equipment.

### TEMPERATURE MEASURING INSTRUMENTS

Temperature is the degree of hotness or coldness of a substance measured on a definite scale. Temperature is measured when a measuring system, such as a thermometer, is brought into contact with the system to be measured. You often need to know the expansion of a liquid, the pressure of a gas, emf, electrical resistance, or some other mechanical, electrical, or optical property that has a definite and known relationship to temperature. Thus we infer the temperature of the measured system by the measurement of some property of the system. The temperature measuring instruments that we discuss are of three types: mechanical, electrical, and mechanical-electrical. The mechanical-electrical temperature instruments are switches.

### MECHANICAL TEMPERATURE MEASURING DEVICES

Since temperature is one of the basic engineering variables, temperature measurement is essential to the proper operation of a shipboard engineering plant. You will frequently be called upon to measure the temperature of steam, water, fuel, lubricating oil, and other vital fluids; in many cases you will have to enter the results of this measurement in engineering records and logs.

Devices used for measuring temperature may be classified in various ways. In this section we will discuss only the expansion thermometer types. Expansion thermometers operate on the principle that the expansion of solids, liquids, and gases

has a known relationship to temperature changes. The types of expansion thermometers discussed here are (1) liquid-in-glass thermometers, (2) bimetallic expansion thermometers, and (3) filled-system thermometers.

### Liquid-in-Glass Thermometers

Liquid-in-glass thermometers are probably the oldest, the simplest, and the most widely used devices for measuring temperature. A liquid-in-glass thermometer (fig. 5-1) has a bulb and a very fine bore capillary tube containing alcohol, or some other liquid that expands uniformly as the temperature rises or contracts uniformly as the temperature falls. The selection of liquid is based on the temperature range in which the thermometer is to be used.

Almost all liquid-in-glass thermometers are sealed so atmospheric pressure does not affect the

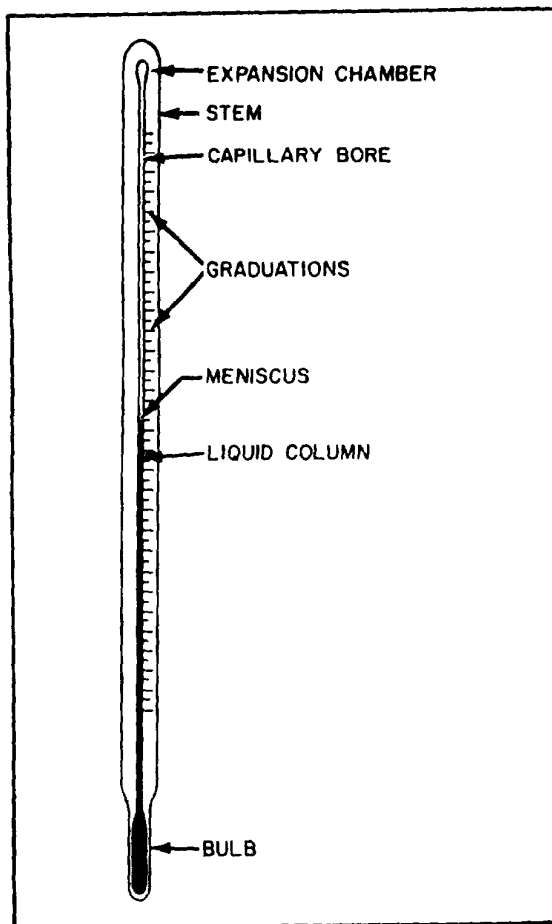

Figure 5-1.—Liquid-in-glass thermometer.

reading. The space above the liquid in this type of thermometer may be a vacuum or filled with an inert gas such as nitrogen, argon, or carbon dioxide.

The capillary bore may be either round or elliptical. In any case, it is very small, so a relatively small expansion or contraction of the liquid causes a relatively large change in the position of the liquid in the capillary tube. Although the capillary bore itself is very small in diameter, the walls of the capillary tube are quite thick. Most liquid-in-glass thermometers have an expansion chamber at the top of the bore to provide a margin of safety for the instrument if it should accidentally be overheated.

Liquid-in-glass thermometers may have graduations etched directly on the glass stem or placed on a separate strip of material located behind the stem. Many thermometers used in shipboard engineering plants have the graduations marked on a separate strip; this type is generally easier to read than the type that has the graduations marked directly on the stem.

You will seldom find liquid-in-glass thermometers on gas turbine ships. As a GSE/GSM, you may still find this type of thermometer in use in the oil and water test lab for analytical tests on fuel, oil, and water.

### Bimetallic Expansion Thermometer

Bimetallic expansion thermometers make use of different metals having different coefficients of linear expansion. The essential element in a

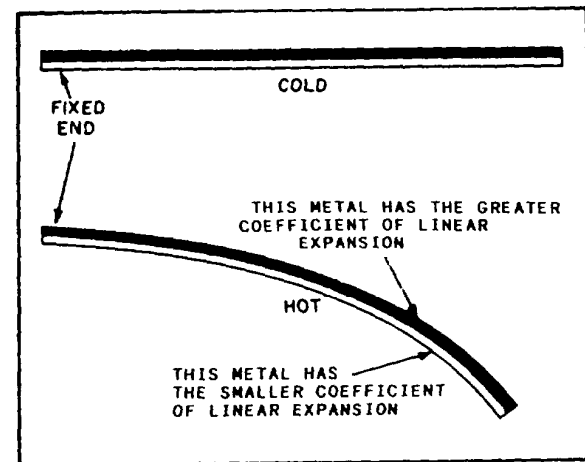

Figure 5-2.—Effect of unequal expansion of a bimetallic strip.

bimetallic expansion thermometer is a bimetallic strip consisting of two layers of different metals fused together. When such a strip is subjected to temperature changes, one layer expands or contracts more than the other, thus tending to change the curvature of the strip.

Figure 5-2 shows the basic principle of a bimetallic expansion thermometer. When one end of a straight bimetallic strip is fixed in place, the other end tends to curve away from the side that has the greater coefficient of linear expansion when the strip is heated.

For use in thermometers, the bimetallic strip is normally wound into a flat spiral (fig. 5-3), a single helix, or a multiple helix. The end of the strip that is not fixed in position is fastened to the end of a pointer that moves over a circular scale. Bimetallic thermometers are easily adapted for use as recording thermometers; a pen is attached to the pointer and positioned in such a way that it marks on a revolving chart.

### Filled-System Thermometers

In general, filled-system thermometers are designed for use in locations where the indicating part of the instrument must be placed some distance away from the point where the temperature is to be measured. For this reason they are often called distant-reading thermometers. However, this is not true of all filled-system thermometers. In a few designs, the capillary tubing is extremely short, and in a few, it is nonexistent. In general, however, filled-system thermometers are designed to be distant-reading thermometers. Some distant-reading thermometers may have capillaries as long as 125 feet.

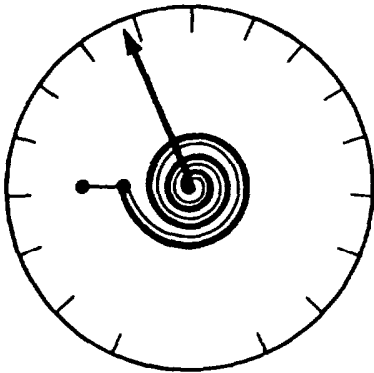

Figure 5-3.—Bimetallic thermometer (flat, spiral strip).

There are two basic types of filled-system thermometers. One has a Bourdon tube that responds primarily to changes in the volume of the filling fluid; the other is one in which the Bourdon tube responds primarily to changes in the pressure of the filling fluid. Clearly, some pressure effect will exist in volumetric thermometers, and some volumetric effect will exist in pressure thermometers.

A distant-reading thermometer (fig. 5-4) consists of a hollow metal sensing bulb at one end of a small-bore capillary tube, which is connected at the other end to a Bourdon tube or other device that responds to volume changes or to pressure changes. The system is partially or completely filled with a fluid that expands when heated and contracts when cooled. The fluid may be a gas, an organic liquid, or a combination of liquid and vapor.

The device usually used to indicate temperature changes by its response to volume changes or to pressure changes is called a Bourdon tube. A Bourdon tube is a curved or twisted tube which is open at one end and sealed

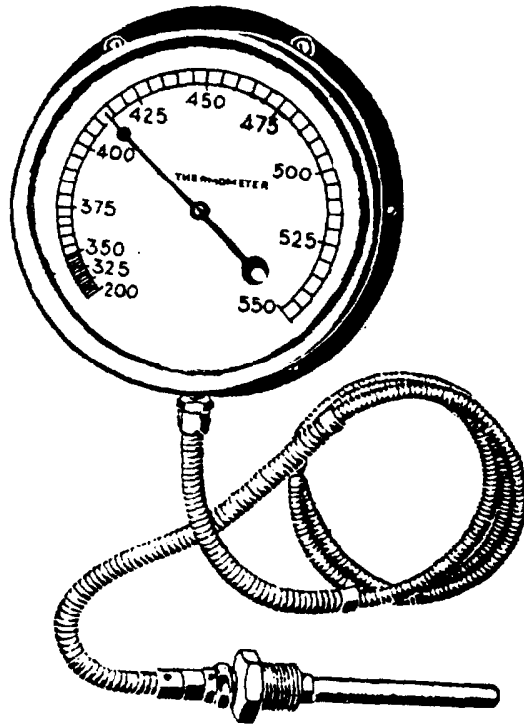

Figure 5-4.—Distant-reading, Bourdon-tube thermometer.

at the other (fig. 5-5). The open end of the tube is fixed in position, and the sealed end is free to move. The tube is more or less elliptical in cross section; it does not form a true circle. It becomes less circular when there is an increase in the volume or in the internal pressure of the contained fluid; this tends to straighten the tube. Opposing this action, the spring action of the tube metal tends to coil the tube. Since the open end of the Bourdon tube is rigidly fastened, the sealed end moves as the volume or pressure of the contained fluid changes. A pointer is attached to the sealed end of the tube through appropriate linkages; the assembly is placed over an appropriately calibrated dial. The result is a Bourdon-tube gauge that may be used for measuring temperature or pressure, depending upon the design of the gauge and the calibration of the scale.

Bourdon tubes are made in several shapes for various applications. The C-shaped Bourdon tube shown in figure 5-5 is perhaps the most commonly used type; spiral and helical Bourdon tubes are used where design requirements include the need for a longer length Bourdon tube.

## ELECTRICAL TEMPERATURE MEASURING DEVICES

On the gas turbine propulsion plant, you will have to monitor temperature readings at remote locations. Expansion thermometers provide indications at the machinery locations or on gauge

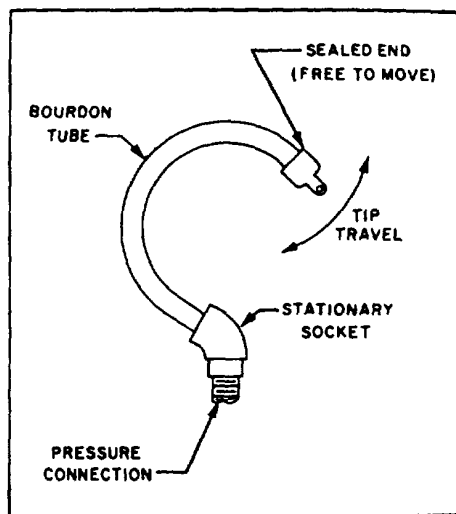

Figure 5-5.—C-shaped Bourdon tube.

panels in the immediate area. To provide remote indications at a central location, you use electrical temperature measuring devices in conjunction with signal conditioners. The devices we will discuss in this section are the resistance temperature detectors (RTDs), the resistance temperature elements (RTEs), and thermocouples. These devices sense variable temperatures at a given point in the system and transmit the signals to a remotely located indicator.

## Resistance Temperature Detectors

The RTDs operate on the principle that electrical resistance changes in a predictable manner with temperature changes. The elements of RTDs are made of nickel, copper, or platinum. Nickel and copper are used for temperatures of 600°F or lower. Platinum elements are used for temperatures of 600°F or greater. Figure 5-6 shows two typical types of RTDs.

As with the bimetallic thermometers, you will usually find RTDs mounted in thermowells. Thermowells protect sensors from physical damage by keeping them isolated from the medium being measured. This arrangement also lets you change the RTD without securing the system in which it is mounted. This makes your maintenance easier and less messy.

As temperature increases around an RTD, the corresponding resistance will also increase at a proportional value. The temperature applied to an RTD, if known, will give you a known resistance value. You can find these resistance values listed in tables in the manufacturers' technical manuals. Normally, only a few resistance values are given.

To test an RTD, you will have to heat it to a specific temperature. At this temperature the resistance of the RTD should be at the resistance shown in the table. The most common method of heating an RTD is to use a pan of hot water and a calibrated thermometer. Some newer ships and repair activities test RTDs using a thermobulb tester. This method is more accurate and easier to use. For specific instructions, refer to the manufacturers' technical manuals supplied with the equipment.

The most common fault you will find with an RTD will be either a short circuit or an open circuit. You can quickly diagnose these faults by using digital display readings or data log print-outs. By observing the reading or the printout, you may find that the indication is either zero or a very low value. A malfunction of this type

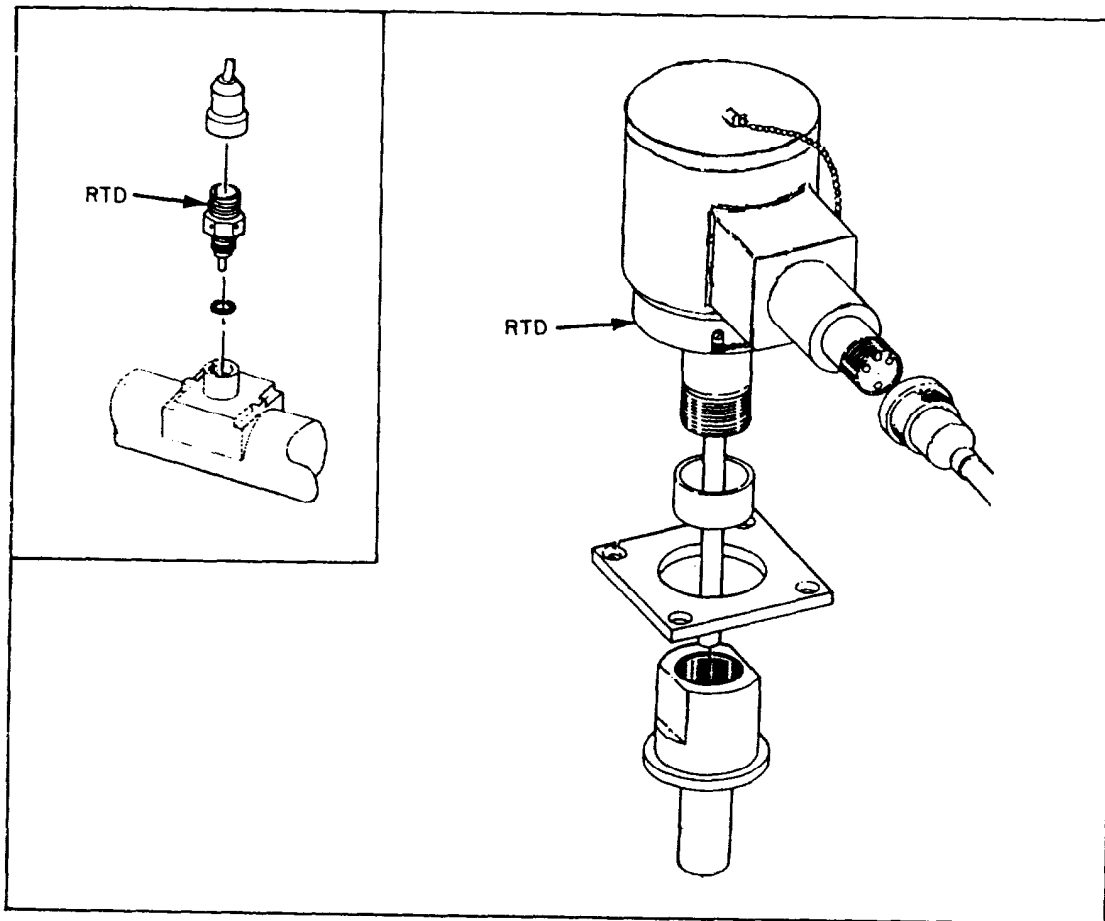

Figure 5-6.—Two typical types of RTDs.

means a short circuit exists in either the RTD or its associated wiring. A very high reading, such as 300°F on a 0°F to 300°F RTD, could indicate an open circuit. You should compare these readings to local thermometers. This ensures that no abnormal conditions exist within the equipment that the RTD serves.

If an RTD is faulty, you should replace it at the earliest opportunity. Internal repairs cannot be made to RTDs at the shipboard level. Until you can replace the faulty RTD, you should inform the watch standers that the RTD is unreliable. The engine-room watch standers should periodically take local readings to ensure the equipment is operating normally.

### Resistance Temperature Elements

The most common types of temperature sensors you will find in gas turbine propulsion plants are the RTEs. They operate on the same principle as the RTDs. As the temperature of the

sensor increases, the resistance of the RTE also increases at a proportional value. All RTEs that you encounter have a platinum element and have an electrical resistance of 100 ohms at a temperature of 32°F. Four different temperature ranges of RTEs are commonly used, but you will find that the probe size varies. The four temperature ranges and their probe sizes are as follows:

| TEMPERATURE RANGE<br>(Degrees Fahrenheit) | RTE PROBE LENGTH<br>(Inches) |
|---|------------------------------|
| -20° to +150°                             | 6                            |
| 0° to +400°                               | 2, 4, 10                     |
| 0° to +1000°                              | 2                            |
| -60° to +500°                             | 6                            |

You may find some RTEs that are connected to remote mounted signal conditioning modules.



These modules convert the ohmic value of the RTE to an output range of 4 to 20 milliamperes (mA) direct current (dc). However, most RTEs read their value directly into the propulsion electronics as an ohmic value.

The 0° to +400°F and the —60° to +500°F range RTEs are commonly mounted in a thermowell. Since you can change the RTE without securing the equipment it serves, this also simplifies maintenance.

### Thermocouples

Thermocouple sensors are used to monitor LM2500 power turbine inlet temperature ( $T_{5.4}$ ) and Allison 501-K17 turbine inlet temperature (TIT). Although each engine uses a different type of thermocouple, the theory of operation is the same. These sensors work on the principle that when two dissimilar metals are fused together at a junction by heat, a small voltage is produced. The amount of this voltage is directly proportional to the  $T_{5.4}$  or TIT.

Figure 5-7 shows the LM2500 and the Allison 501-K17 thermocouples. You should note that although they are physically different, their operation is the same. Both thermocouples

are composed of the metals Chromel and Alumel.

**LM2500 THERMOCOUPLES.**—The LM2500 uses eleven thermocouples to monitor  $T_{5.4}$ . Individual thermocouples cannot be replaced though, as they are arranged in four groups. These groups, or harnesses, are the components you must change if you have a faulty thermocouple. Figure 5-8 shows the four harnesses. You should note that the two upper harnesses and the lower right harness each contains three thermocouples. The lower left harness has only two thermocouples. Be very careful when you replace a harness. Take care not to damage a probe or bend the harness. For complete detailed information on replacement of thermocouple harnesses, refer to the *Propulsion Gas Turbine Module LM2500*, Volume 2, Part 3, NAVSEA S9234-AD-MMO-050.

**ALLISON 501-K17 THERMOCOUPLES.**—Eighteen dual-element, Chromel-Alumel thermocouples are used on the Allison 501-K17 to monitor TIT. Unlike the thermocouples of the LM2500, you can change these thermocouples individually. Each of these sensors has two independent elements that allow two sampling circuits per thermocouple. Only one circuit is used for monitoring TIT; the other circuit is not

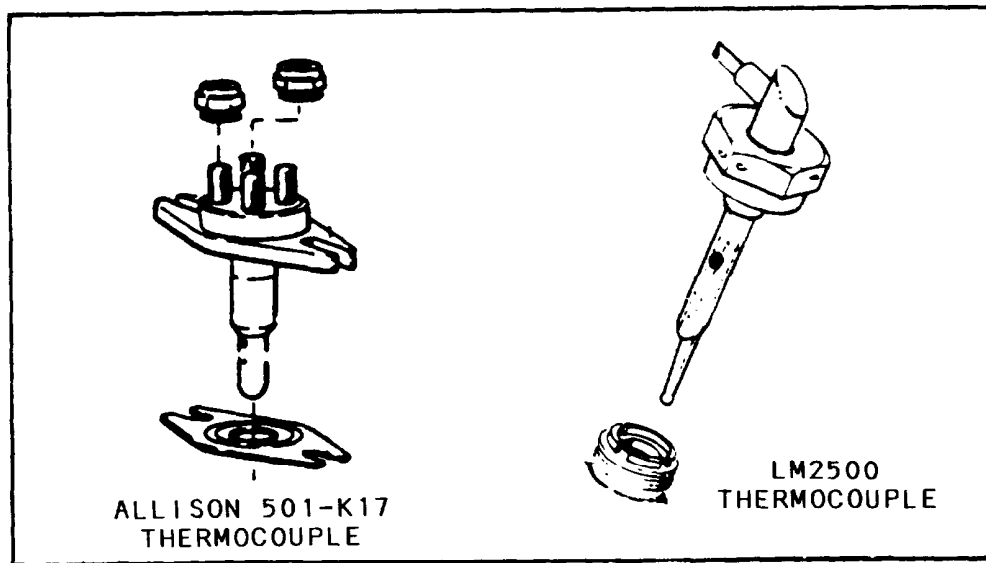

Figure 5-7.—Thermocouples.

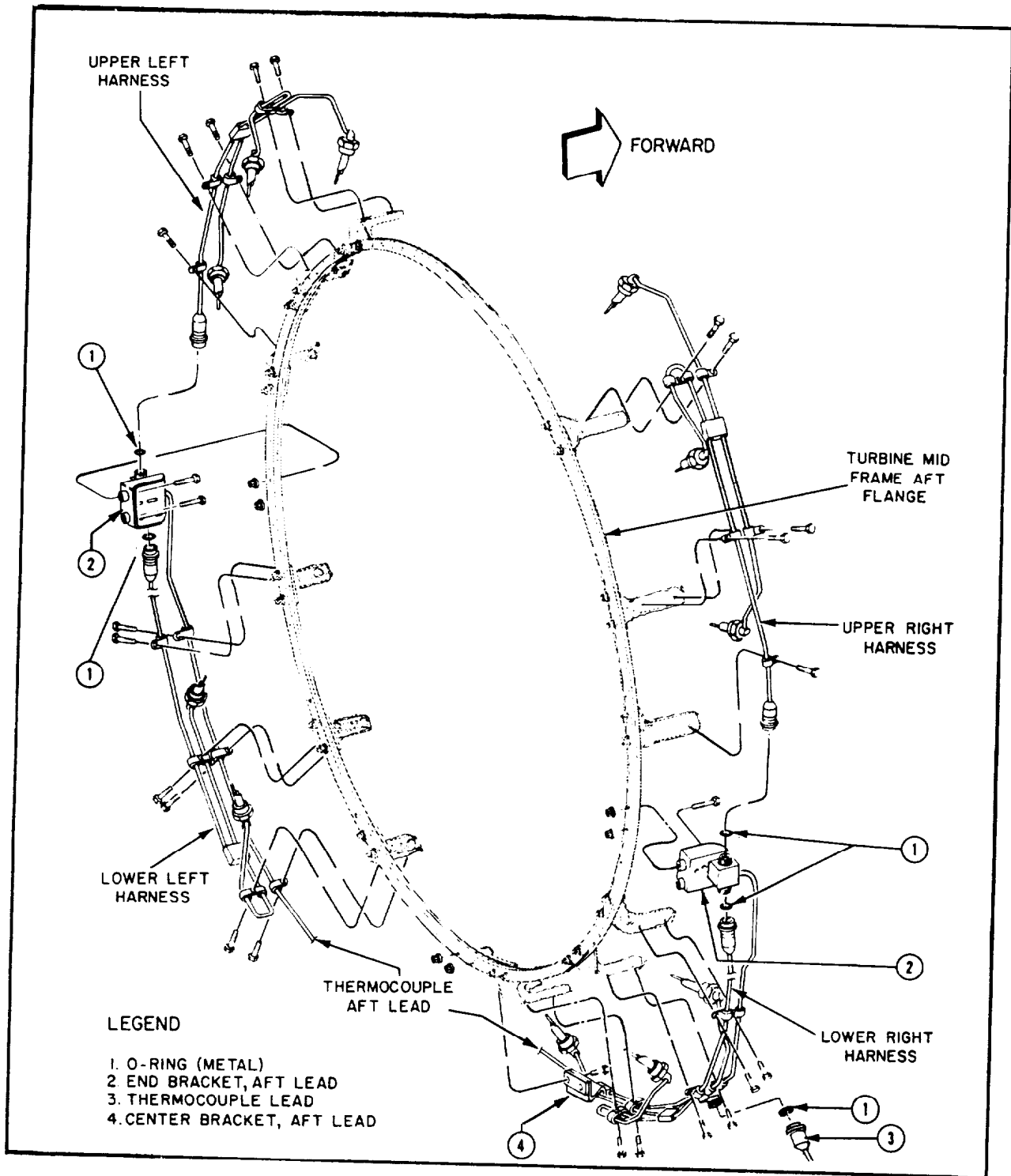

Figure 5-8.—LM2500 thermocouple harness.

monitored. Figure 5-9) shows the thermocouple installation on the Allison 501 - K17.

The interconnecting harness for the thermocouples, as shown in figure 5-9, mounts on the outer combustion case forward of the thermocouples. This harness includes four separate leads for each of the eighteen sensors. Two separate electrical circuits are maintained. The harness is made in two halves, a right-hand side and a left-hand side. Note in figure 5-9 that the harness is split near the thermocouple junction. This allows you to easily remove the wiring without major engine disassembly. The electrical signals from the thermocouples are averaged within the harness. The output of the thermocouple harness is sent to the local operating panel (LOCOP) for signal conditioning.

A faulty thermocouple will give you a false TIT reading. The TIT is a basic parameter for the liquid fuel valve (LFV) adjustment. Therefore, a faulty sensor would result in an incorrectly adjusted LFV. You should check the continuity of the thermocouples if you suspect the TIT reading is incorrect. Also, check it if you suspect the LFV is out of adjustment. The thermocouple continuity is read with an ohmmeter. Each thermocouple has four terminals, but only two are used for monitoring TIT. Find the two terminals that are used for TIT and read the resistance between them. If the reading on a thermocouple is over 10 ohms, you must replace that sensor.

For instructions on thermocouple replacement, refer to the appropriate manufacturers' technical manuals.

## TEMPERATURE SWITCHES

Temperature switches operate from temperature changes occurring in an enclosure, or in the air surrounding the temperature sensing element. The operation of the temperature switch is not much different than that of the pressure switch. Actually, both switches are operated by changes in pressure. The temperature element is arranged so changes in temperature cause a change in the internal pressure of a sealed-gas or air-filled bulb or helix, which is connected to the actuating device by a small tube or pipe. Figure 5-10 shows you a temperature switch and two types of sensing elements.

### Construction

You can connect the bulb and helix units to the switch section. The bulb unit (fig. 5-10, item A) is normally used when you need to control liquid temperatures. However, it may control air or gas temperatures. This only happens if the circulation around it is rapid and the temperature changes at a slow rate.

The helical unit (fig. 5-10, item B) has been specifically designed for air and gas temperature

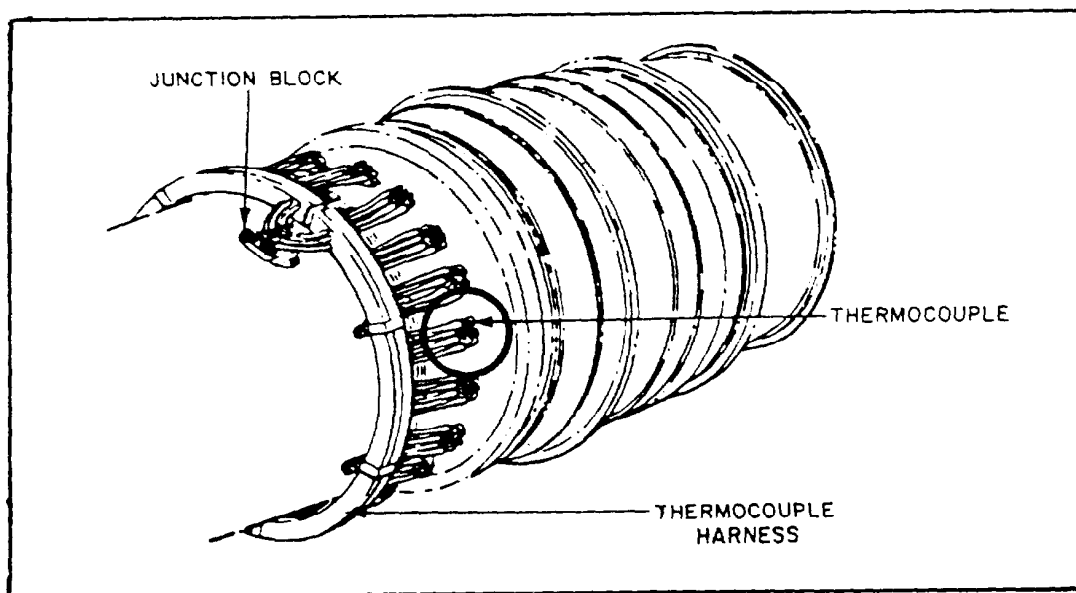

Figure 5-9.—Allison 501-K17 thermocouple harness.

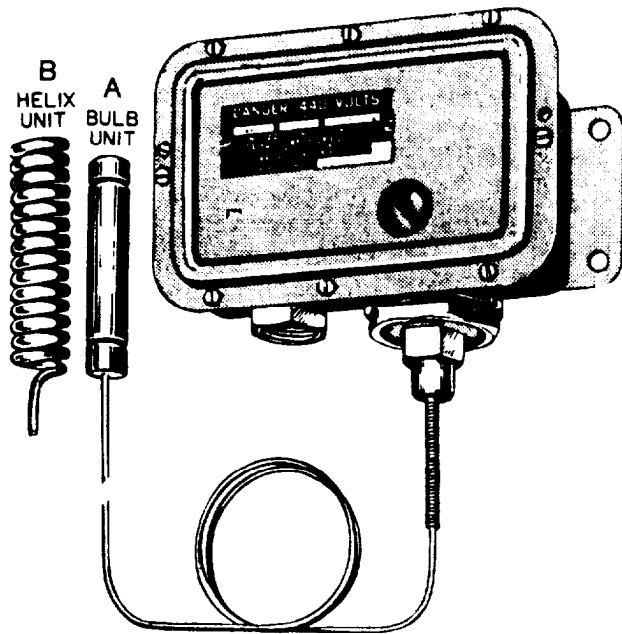

Figure 5-10.—Temperature switch with two types of sensing elements. A . Bulb unit. B. Helix unit.

control circuits. For the thermal unit to be most effective, it must be located at a point of unrestricted circulation. This is so it can “feel” the average temperature of the substance you wish to control.

Temperature changes cause a change in the volume of the sealed-in gas, which causes movement of a diaphragm. The movement is transmitted by a plunger to the switch arm. The moving contact is on the arm. A fixed contact may be arranged so the switch will open or close on a temperature rise. This allows the switch contacts to be arranged to close when the temperature drops to a predetermined value and to open when the temperature rises to the desired value. The reverse action can be obtained by a change in the contact positions.

The difference in temperature for the contact opening set point and closing set point is the differential. The switch mechanism has a built-in differential adjustment so the differential can be varied over a small range. Once set, the differential remains essentially constant at all temperature settings.

Some switches are stamped WIDE DIFFERENTIAL. These switches are adjusted in the same manner described for the regular controls. However, because of slight design changes, it is

possible to get wider variation in differential settings.

### Adjustments

To set the operating range of the switch, turn the differential adjustment screw (fig. 5-11) counterclockwise against the stop for minimum differential. Bring the temperature to the value at which the circuit is to be closed. If the switch contacts are open at this temperature, turn the range screw slowly clockwise until the contacts close. If the contacts are closed when the desired temperature is reached, turn the range screw counterclockwise until the contacts open; then turn the screw slowly clockwise until the contacts close. These adjustments set the closing temperature.

The temperature is now raised to the point where the circuit is to be opened. Since the differential adjustment is now set at minimum, the circuit will probably open at a lower temperature than desired; therefore, turn the differential adjustment screw clockwise to widen the differential until the desired opening temperature is obtained. For further instructions on how to adjust these switches, refer to the manufacturers’ technical manuals.

## PRESSURE MEASURING INSTRUMENTS

Pressure, like temperature, is one of the basic engineering measurements and one that must be

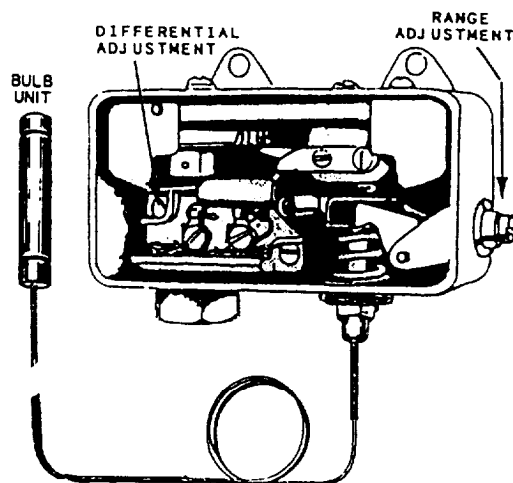

Figure 5-11.—Temperature switch.

frequently monitored aboard ship. As with temperature readings, pressure readings provide you with an indication of the operating condition of equipment. Pressure measuring instruments that we discuss are of three types: mechanical, electrical, and mechanical-electrical. The mechanical-electrical pressure instruments are switches.

### MECHANICAL PRESSURE MEASURING INSTRUMENTS

Two of the primary mechanical pressure measuring instruments found aboard ship are the

Bourdon-tube and the bellows elements. Bourdon-tube elements are suitable for the measurement of very high pressures up to 100,000 psig. The upper limit for bellows elements is about 800 psig.

### Bourdon-Tube Elements

Bourdon-tube elements used in pressure gauges are essentially the same as those described for use in filled-system thermometers. Bourdon tubes for pressure gauges are made of brass, phosphor bronze, stainless steel,

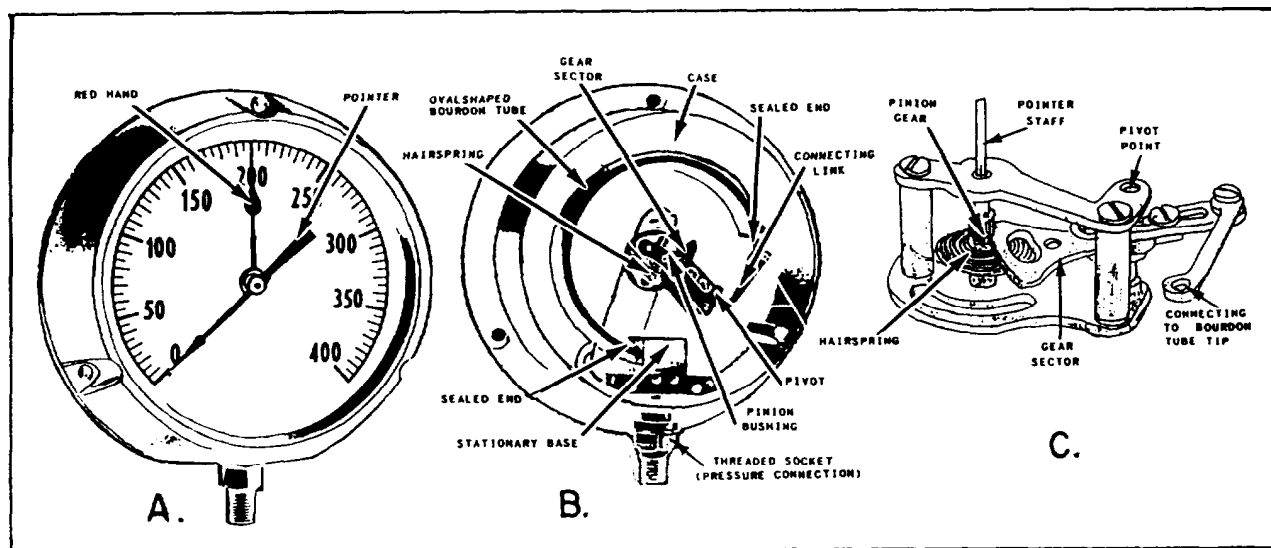

Figure 5-12.—Simplex Bourdon-tube pressure gauge.

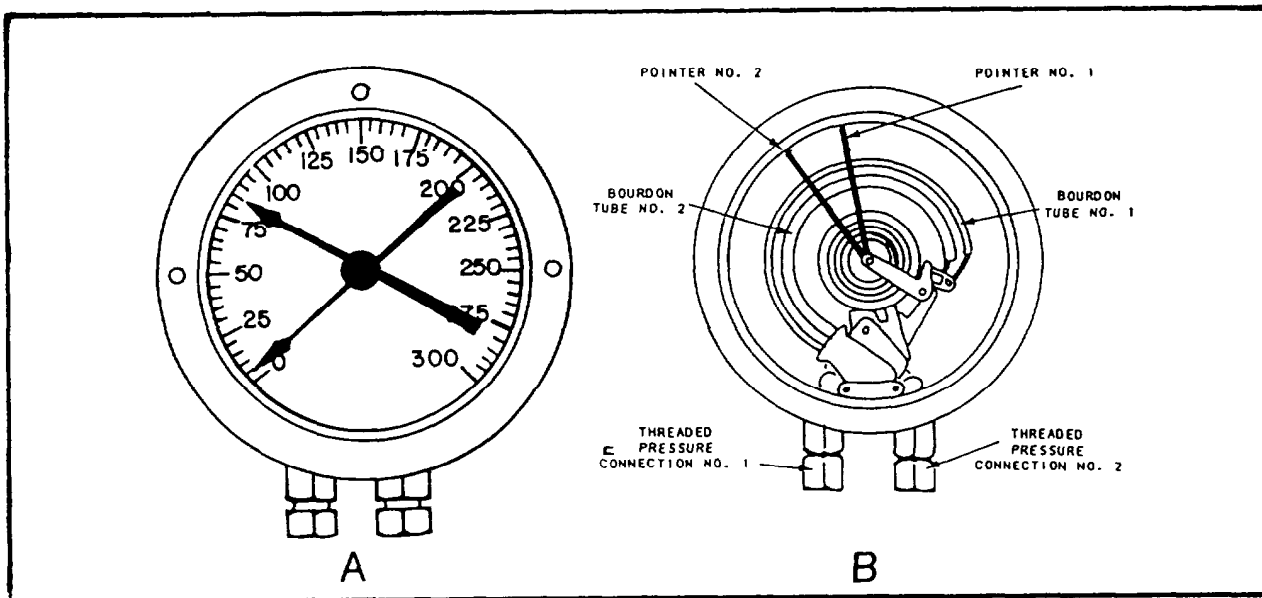

Figure 5-13.—Duplex Bourdon-tube pressure gauge.

beryllium-copper, or other metals, depending upon the requirements of service.

Bourdon-tube pressure gauges are often classified as simplex or duplex, depending upon whether they measure one pressure or two. A simplex gauge has only one Bourdon tube and measures only one pressure. Figure 5-12 shows a simplex Bourdon-tube pressure gauge with views of the dial and gear and operating mechanisms. The pointer marked RED HAND in view A is a manually positioned hand that is set at or slightly above the maximum normal operating pressure of the machinery. The hand marked POINTER is the only hand that moves in response to pressure changes.

When two Bourdon tubes are mounted in a single case, with each mechanism acting independently but with the two pointers mounted

on a common dial, the assembly is called a duplex gauge. Figure 5-13 shows a duplex gauge with views of the dial and operating mechanism. Note that each Bourdon tube has its own pressure connection and its own pointer. Duplex gauges are used to give simultaneous indication of the pressure at two different locations.

Bourdon-tube vacuum gauges are marked off in inches of mercury, as shown in figure 5-14. When a gauge is designed to measure both vacuum and pressure, it is called a compound gauge; it is marked off both in inches of mercury and in psig, as shown in figure 5-15.

Differential pressure may also be measured with Bourdon-tube gauges. One kind of Bourdon-tube differential pressure gauge is shown in figure 5-16. This gauge has two Bourdon tubes

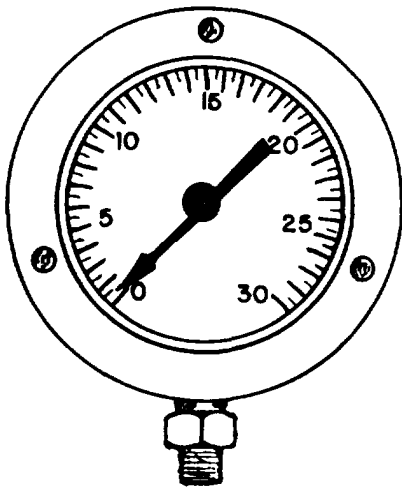

Figure 5-14.—Bourdon-tube vacuum gauge.

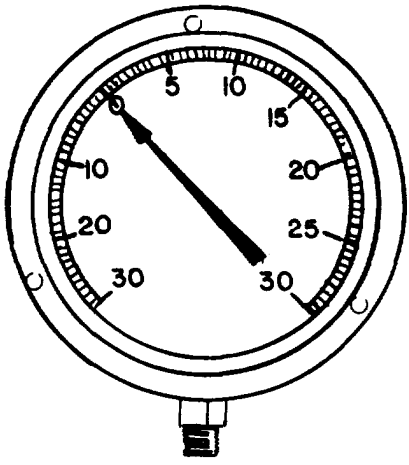
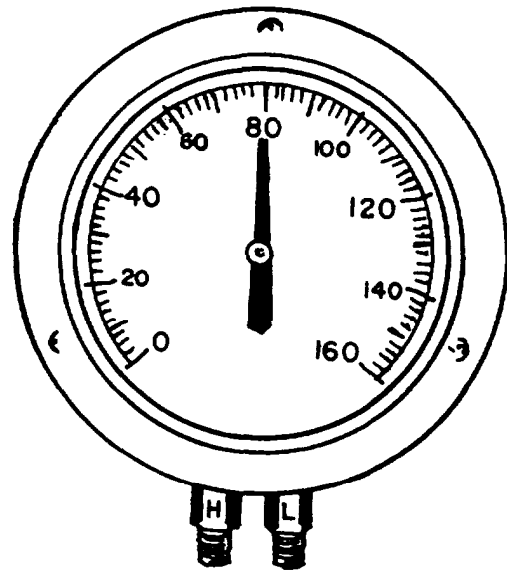

Figure 5-15.—Compound Bourdon-tube gauge.

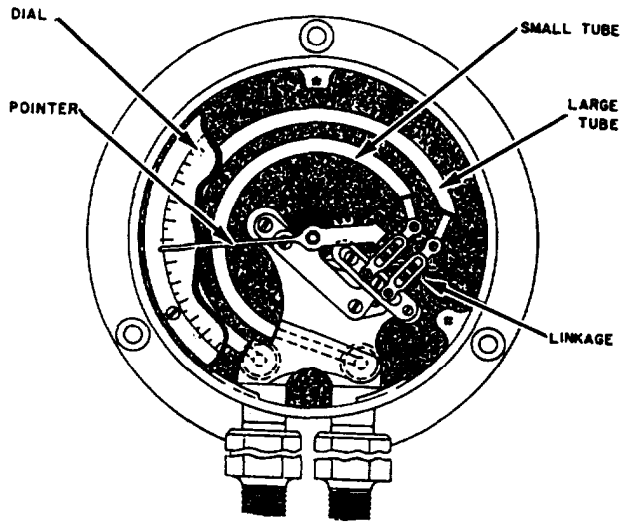

Figure 5-16.—Bourdon-tube differential pressure gauge.

but only one pointer. The Bourdon tubes are connected in such a way that they are the pressure difference, rather than either of the two actual pressures indicated by the pointer.

### Bellows Element

A bellows elastic element is a convoluted unit that expands and contracts axially with changes in pressure. The pressure to be measured can be applied to the outside or to the inside of the bellows; in practice, most bellows measuring devices have the pressure applied to the outside of the bellows, as shown in figure 5-17. Like Bourdon-tube elements, bellows elastic elements are made of brass, phosphor bronze, stainless

steel, beryllium-copper, or other metal suitable for the intended service of the gauge.

Most bellows gauges are spring-loaded--that is, a spring opposes the bellows and thus prevents full expansion of the bellows. Limiting the expansion of the bellows in this way protects the bellows and prolongs its life. In a spring-loaded bellows element, the deflection is the result of the force acting on the bellows and the opposing force of the spring.

Although some bellows instruments can be designed for measuring pressures up to 800 psig, their primary application aboard ship is in the measurement of quite low pressures or small pressure differentials.

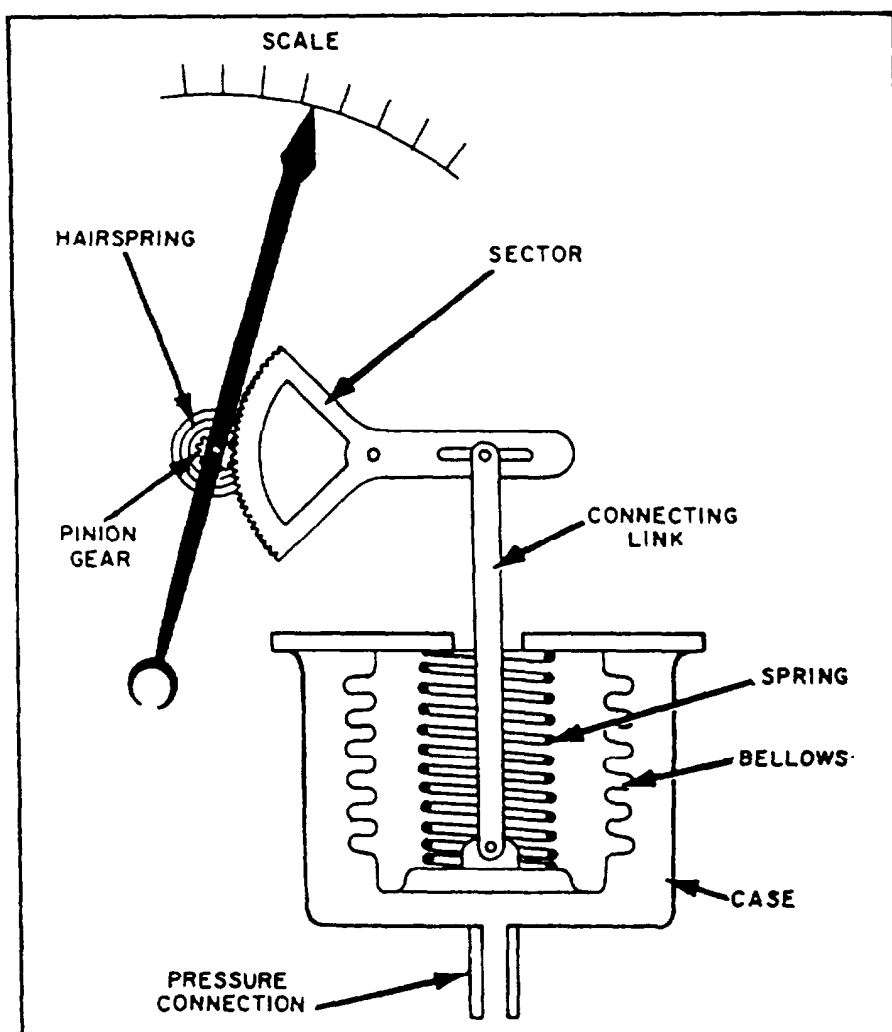

Figure 5-17.—Bellows gauge.

Many differential pressure gauges are of the bellows type. In some designs, one pressure is applied to the inside of the bellows and the other pressure is applied to the outside. In other designs, a differential pressure reading is obtained by opposing two bellows in a single case.

Bellows elements are used in various applications where the pressure-sensitive device must be powerful enough to operate not only the indicating pointer but also some type of recording device.

## ELECTRICAL PRESSURE MEASURING INSTRUMENTS (TRANSDUCERS)

Transducers are devices that receive energy from one system and retransmit it to another system. The energy retransmitted is often in a different form than that received. In this section, we will discuss the pressure transducer. This device receives energy in the form of pressure and retransmits energy in the form of electrical current.

Transducers allow monitoring at remote locations on gas turbine propulsion plants. Mechanical gauges provide pressure readings at the machinery locations or on gauge panels in the immediate area. At a central location remote readings are provided by using transducers in

conjunction with signal conditioners. Transducers provide the capability of sensing variable pressures and transmitting them in proportional electrical signals. Pressure transducers, like pressure switches, are widely used in ship propulsion and auxiliary machinery spaces. They are used to monitor alarms and in machinery operation.

### Pressure Transducer Operation

Pressure transducers are generally designed to sense absolute, gauge, or differential pressure. The typical unit (fig. 5-18) receives pressure through the pressure ports. It transmits an electrical signal, proportional to the pressure input, through the electrical connector. Pressure transducers are available in pressure ranges from 0 to 6 inches water differential to 0 to 10,000 psig. Regardless of the pressure range of a specific unit, the electrical output is always the same. The electrical signal is conditioned by the signal conditioners before being displayed on an analog meter or a digital readout located on one of the control consoles.

### Pressure Transducer Calibration

Pressure transducers should be calibrated on a bench before installation. The equipment needed

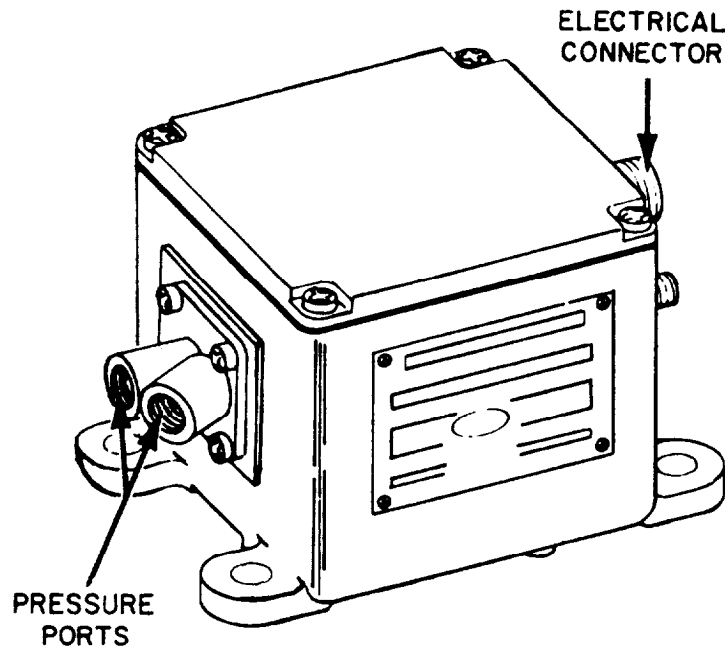

Figure 5-18.—Pressure transducer assembly.



and its setup are shown in figures 5-19 and 5-20. After setting up your test equipment as shown, you will be ready to start calibrating the transducer. If your ship doesn't have a calibration lab or isn't qualified to calibrate gauges, then

you will have to send your transducers to a calibration activity. If you have a problem with a transducer or have to replace a transducer, you can compare it to a known standard by using the calibration kit.

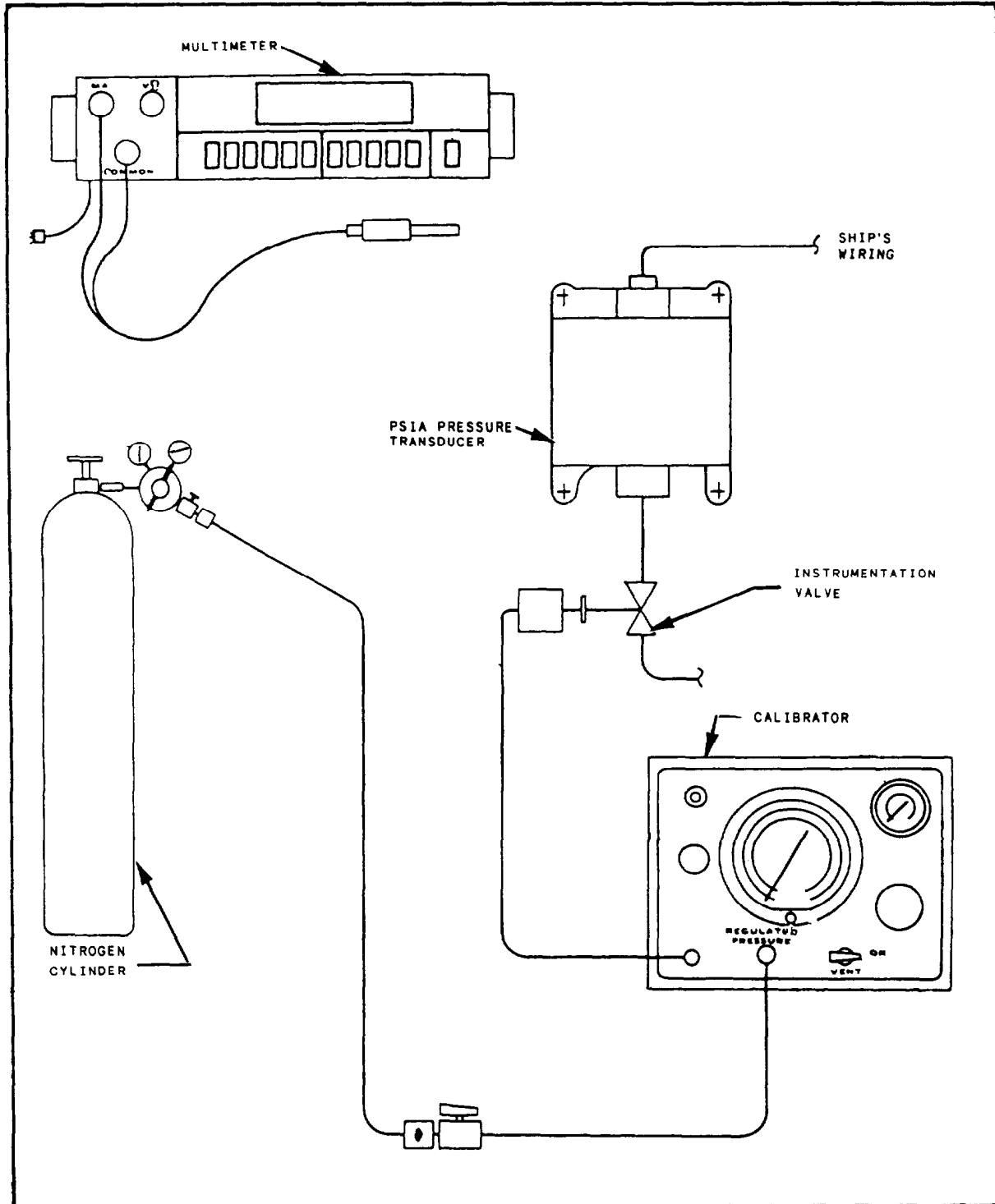

Figure 5-19.—Calibration setup for absolute pressure transducers.

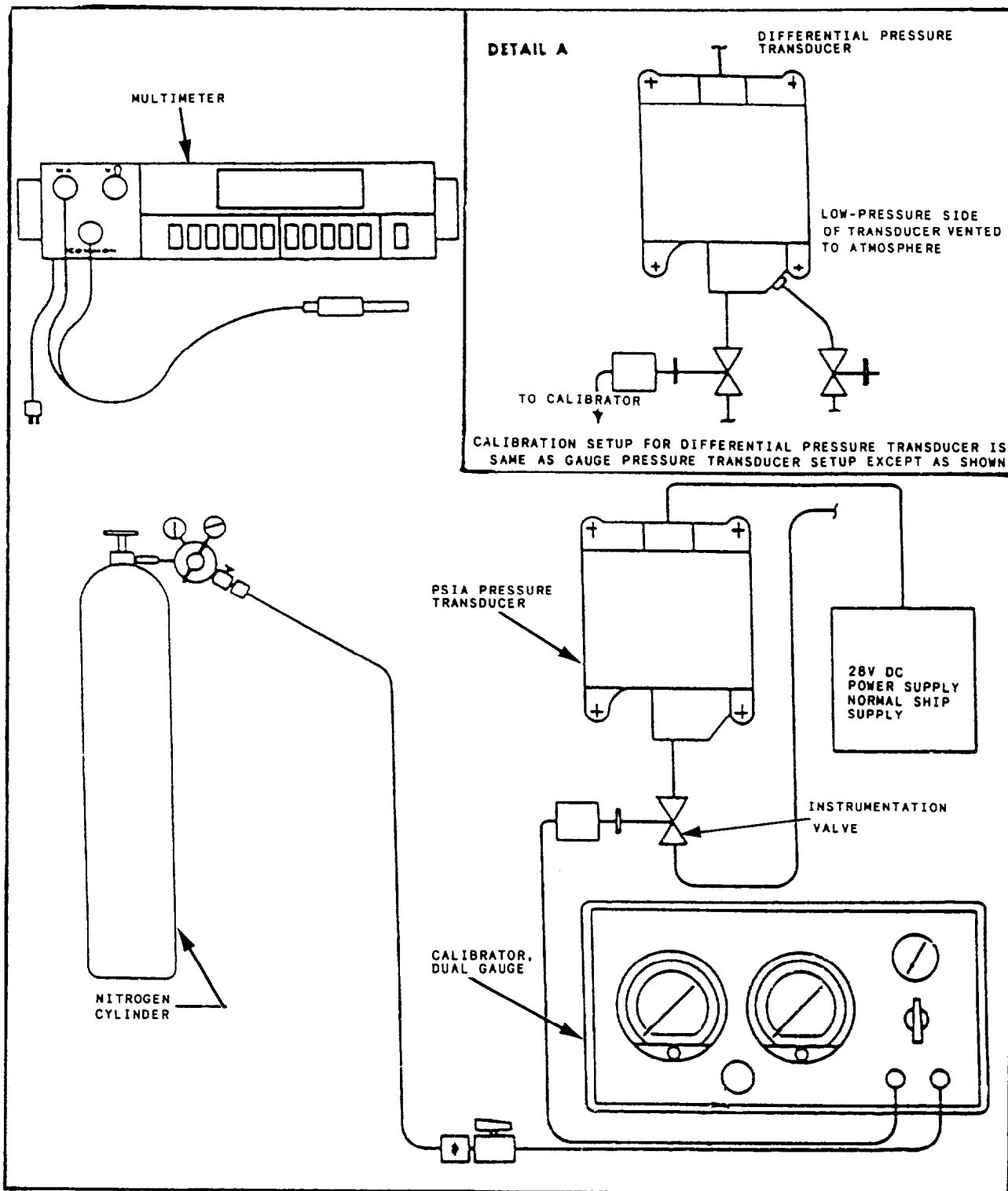

Figure 5-20.—Calibration setup for pressure transducers.

The following simple setup procedural steps should help you understand and calibrate pressure transducers commonly found on gas turbine ships. These steps are condensed from paragraphs 8.2-24 and 8.2-25 of the *Propulsion Gas Turbine Module LM2500*, Volume 2, Part 3, NAVSEA S9234-AD-MMO-050.

To calibrate a 0- to 250-psig transducer, close the instrumentation valve and remove the cap. Remove the cover from the transducer and connect the multimeter. The multimeter should read  $4 \text{ mA} \pm 0.3$ . If necessary, adjust the ZERO ADJUST potentiometer. Now connect the pressure hose to the instrumentation valve and apply 250 psig to the transducer. The multimeter should read  $20 \text{ mA} \pm 0.3$ . If necessary, adjust the SPAN ADJUST potentiometer to obtain this reading. Recheck first and last values whenever you make either ZERO or SPAN adjustments. Now check the middle value, in this case 125 psi, and the multimeter should read  $12 \text{ mA} \pm 0.3$ . To derive the middle value of the output current, subtract 4 from 20, divide by 2, and add 4 to the sum. For information on calibration of transducers, refer to the *Propulsion Gas Turbine Module LM2500*, Volume 2, Part 3, NAVSEA S9234-AD-MMO-050, or *Pressure Transducer - Strain Gauge Assembly*, NAVSEA 0987-LP-059-5010.

**NOTE: When calibrating a differential pressure transducer, apply the pressure to the high port and vent the low port to the atmosphere.**

## PRESSURE SWITCHES

Another type of pressure indicating instrument is the contact or pressure switch. This instrument either opens or closes a set of contacts at a preset pressure. This switch can provide you with an alarm indication or initiate an action such as stopping a piece of equipment at a preset pressure.

Often when a measured pressure reaches a certain maximum or minimum value, a pressure sensing device activates. This may be in the form of an alarm to sound a warning or a light to give a signal. The pressure switch shown in figure 5-21 is a device commonly used to energize or de-energize an auxiliary control system. This switch is normally contained in a metal case with a removable cover. It is equipped with a pressure port and an electrical connector. The pressure switch converts, through a set of contacts, the motion of a diaphragm or bellows into an

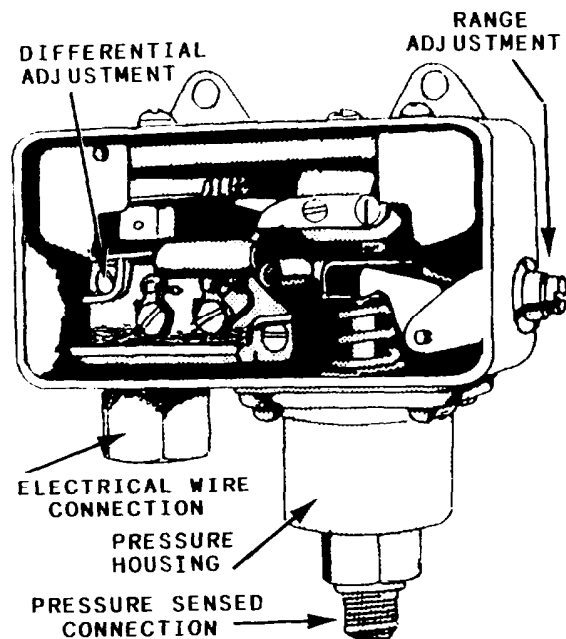

Figure 5-21.—Pressure switch.

electrical signal. Pressure switches are used to sense gauge or differential pressures on pneumatic as well as hydraulic systems. They are manufactured in many sizes and configurations, but all perform basically the same function.

## Construction of Pressure Switches

One of the simplest pressure switches is the single-pole, single-throw, quick-acting one, also shown in figure 5-21. This switch contains a seamless metallic bellows in the housing, which is displaced by changes in pressure. The bellows works against an adjustable spring that determines the pressure needed to actuate the switch. Through suitable linkages, the spring causes the contacts to open or close the electrical circuit. This is done automatically when the operating pressure falls or rises from a specified value. A permanent magnet in the switch mechanism provides a positive snap on both the opening and the closing of the contacts. This snap action prevents excessive arcing of the contacts. The switch is constantly energized. However, it is the closing of the contacts that energizes the entire electrical circuit.

You can find switches in many sizes and configurations. The switch used depends upon its application.

## Setting Pressure Switches

To set a pressure switch, you first have to set a known pressure in the operational range of the switch. Normally, you do this by using a test setup like that shown in figure 5-22. In an emergency, you can use the pressure of the system in which the switch is installed. But you should reset the switch as soon as possible using a calibrator. Many types of pressure calibrators are used in the fleet. Refer to the manufacturer's technical manual for the correct operating instructions for your unit.

The adjustments on the pressure switches are the same as the adjustments on the temperature switches that we described earlier in this chapter.

## LIQUID LEVEL INDICATORS

In a gas turbine propulsion plant, you will have to monitor systems and tanks for liquid level. Sometimes you are only required to know if a level exceeds or goes below a certain preset parameter. Other circumstances require that you know the exact level. If only a predetermined limit is needed, you can use a float switch. This will make contact when the set point is reached and will sound an alarm. If you need to know a specific level, then you must use a variable sensing device.

The sensor used for indicating a tank level is commonly called a tank level indicator (TLI). This sensor will tell you the exact amount of liquid in a tank. In the following paragraphs we will describe the operation of each of these sensors and their applications. Refer to the manufacturers' technical manuals for more information on the procedures used to adjust each type of device.

## TANK LEVEL INDICATORS

Many tank levels on gas turbine ships are monitored to provide the exact liquid level in them. Fuel tanks, for example, are monitored to ensure they do not overflow. They are also monitored to let the engineer officer know the amount of fuel aboard the ship. The sensors used to monitor these levels are TLIs. Each of the level-monitored tanks contains a level transmitter. A typical transmitter section contains a voltage divider resistor network extending the length of the section. Magnetic reed switches are tapped at 1-inch intervals along the resistor network. The reed switches are sequentially connected through series resistors to a common conductor. This network is enclosed in a stem that is mounted vertically in the tank. A float containing bar magnets rides up and down the stem as the level changes.

In many tanks, you have to use more than one transmitter section to measure the full range. The

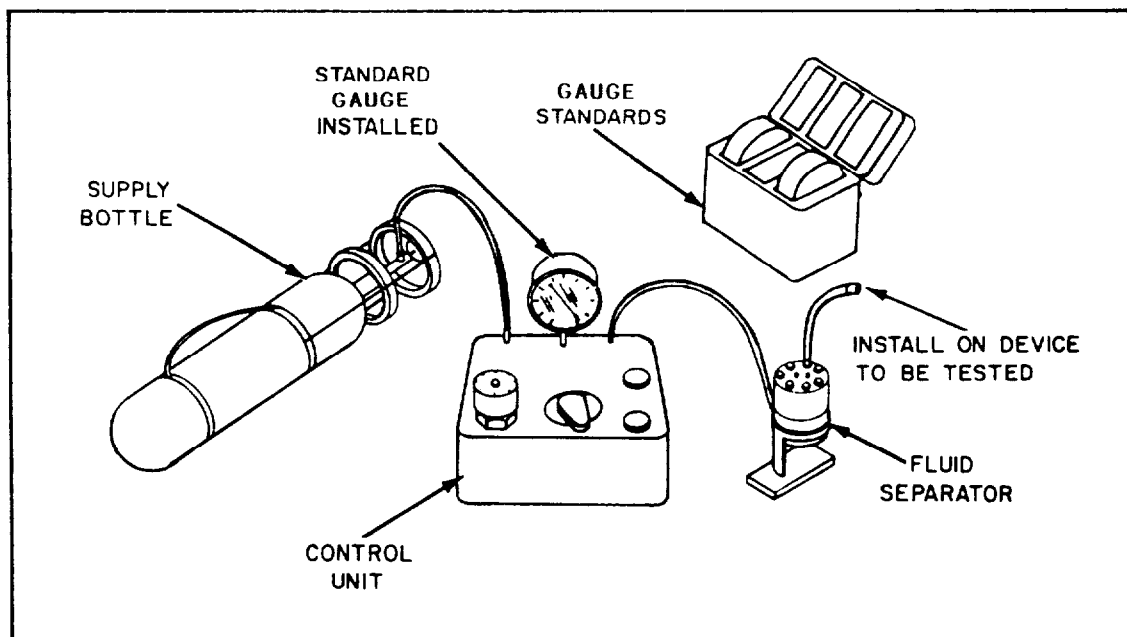

Figure 5-22.—Typical setup for calibrating a pressure device.

physical arrangement of some tanks makes this necessary. When multiple sections are used, they are electrically connected as one continuous divider network.

Two types of floats are used. In noncompensated tanks, the float is designed to float at the surface of the fuel or JP-5. For seawater compensated tanks, the float is designed to stay at the seawater/fuel interface.

### CONTACT LEVEL SENSORS

Many times you do not have to know the exact level of a tank until it reaches a preset level. When this type of indication is needed, you can use a contact or float switch. Two types of float level switches are used on gas turbine ships. One type

is the lever operated switch. It is activated by a horizontal lever attached to a float. The float is located inside the tank. When the liquid level reaches a preset point, the lever activates the switch.

The other type of level switch uses a magnet-equipped float sliding on a vertical stem. The stem contains a hermetically sealed, reed switch. The float moves up and down the stem with the liquid level. It magnetically opens or closes the reed switch as the float passes over it. Figure 5-23 shows the construction of the magnetically operated float switch. Magnetic float switches may be constructed with more than one float on a stem. This type of switch can detect multiple levels in the same tank, such as a high- and low-level alarm. You may also wire multiple stems together to provide this same feature.

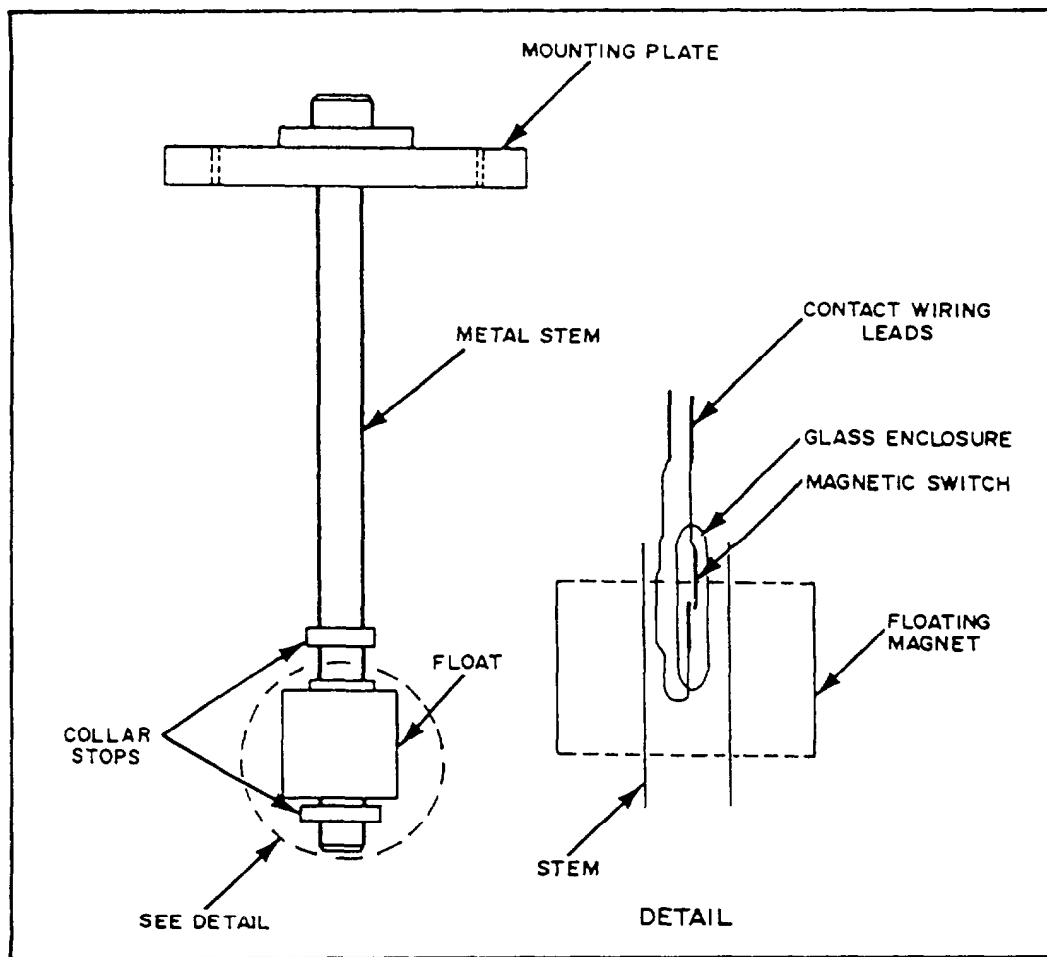

Figure 5-23.—Magnetic float switch.

## ELECTRICAL INDICATING INSTRUMENTS

Electrical indicating instruments (meters) are used to display information that is measured by some type of electrical sensor. Meters on the control console, although they display units such as pressure or temperature, are in fact dc voltmeters. The signal being sensed is conditioned by a signal conditioner. It is then converted to 0- to 10-volt dc, proportional to the parameters being sensed. Electrical values, such as wattage and current, are measured and displayed at ship's service switchboards. The electrical values are then conditioned and displayed on the electric plant console. The meters on the electrical plant console are also the 0- to 10-volt dc type of meters. The meters we will discuss in this chapter are found on the ship's service switchboards. Normally, shipboard repair is not done on switchboard meters. If you suspect the switchboard meters are out of calibration or broken, you should have them sent to a repair facility. You can find more information on the theory of operation of these meters in the Navy Electricity and Electronics Training Series (NEETS), Module 3, *Introduction to Circuit Protection, Control, and Measurement*, NAV-EDTRA 172-03-00-79.

### VOLTMETERS

Both dc and ac voltmeters determine voltage the same way. They both measure the current that the voltage is able to force through a high resistance. Voltage measuring is always connected in parallel with (across) a circuit. The

voltmeters installed in switchboards and control consoles (fig. 5-24) all have a fixed resistance value. Portable voltmeters, used as test equipment, usually have a variable resistance. These resistances are calibrated to the different ranges that the meters will display. The normal range for the switchboard and electric plant meters is 0 to 600 volts.

### AMMETERS

Ammeters (fig. 5-25) are used to indicate the current passing through a conductor. Different types of ammeters are used for either ac or dc. However, any ac ammeter will indicate on dc with a lower degree of accuracy.

The construction of installed ammeters is such that they are not able to handle the current that passes through the conductor being measured. Ammeters are required to be connected in series with the circuit to be measured. Since the meters cannot handle the high switchboard current, the switchboard ammeters operate through current transformers. This arrangement isolates the instruments from line potential. The current transformer produces in its secondary a definite fraction of the primary current. This arrangement makes it possible to measure large amounts of current with a small ammeter.

### CAUTION

**THE SECONDARY OF A CURRENT TRANSFORMER CONTAINS A DANGEROUS VOLTAGE. NEVER WORK AROUND OR ON CURRENT TRANSFORMERS WITHOUT TAKING PROPER SAFETY PRECAUTIONS.**

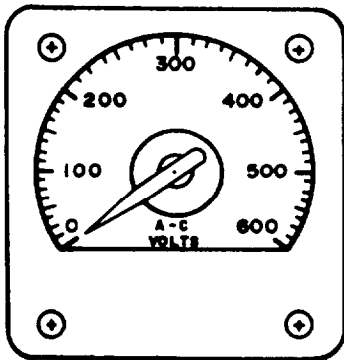

Figure 5-24.—An ac voltmeter.

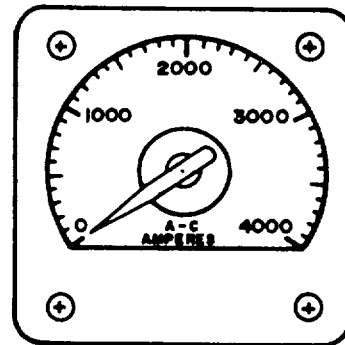

Figure 5-25.—An ac ammeter.

## FREQUENCY METERS

Frequency meters (fig. 5-26) measure the cycles per second rate of ac. The range of frequency meters found on gas turbine ships is between 55 hertz (Hz) and 65 hertz. Frequency of the ac used on ships rarely varies below 57 Hz and seldom exceeds 62 Hz. A frequency meter may have a transducer that converts the input frequency to an equivalent dc output. The transducer is a static device employing two separately tuned series resonant circuits that feed a full-wave bridge rectifier. A change in frequency causes a change in the balance of the bridge. This causes a change in the dc output voltage.

## KILOWATT METERS

Wattage is measured by computing values of current, voltage, and power factor. The kilowatt meters used on ships automatically take these values into account when measuring kilowatt (kW) produced by a generator. Kilowatt meters

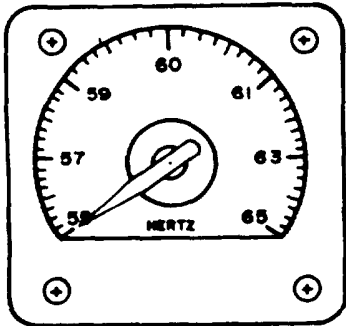

Figure 5-26.—Frequency meter.

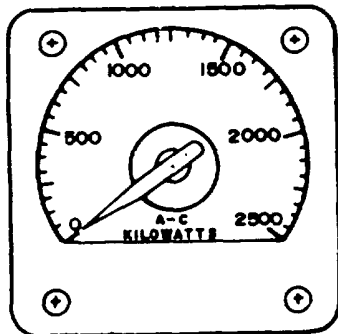

Figure 5-27.—Kilowatt meter.

are connected to both current and potential transformers to allow them to measure line current and voltage. The kW meter shown in figure 5-27 is similar to the ones used on gas turbine ships. Since each type of generator on gas turbine ships is rated differently, the scale will be different on each class of ship.

The amount of power produced by a generator is measured in kilowatts. Therefore, when balancing the electrical load on two or more generators, you should ensure kW is matched. Loss of the kW load is the first indication of a failing generator. For example, two generators are in parallel and one of the two units experiences a failure. To determine which of the two units is failing, compare the kW reading. Normally, the generator with the lowest kW would be the failing unit. However, you should know there is one case where this is not true. During an overspeed condition, both units will increase in frequency. But the failing unit will be the one with the higher kW load.

## SYNCHROSCOPES

Before connecting a 3-phase generator to bus bars already connected to one or more other generators, you must ensure that certain conditions prevail. A synchroscope is the device you will use to find out if the following conditions have been met:

1. Phase sequence must be the same for generator and bus bars.
2. Generator and bus-bar voltage must be the same.
3. Generator and bus-bar frequency must be the same.
4. Generator frequency must be practically constant for an appreciable period of time.
5. The generator and bus-bar voltage must be in phase. They must reach their maximum voltages at the same time. This is so that when connected, they will oppose excessive circulation of current between the two machines.

Figure 5-28 shows a synchroscope. It is basically a power factor meter connected to measure the phase relation between the generator and bus-bar voltages. The moving element is free to rotate continuously. When the two frequencies are exactly the same, the moving element holds a fixed position. This shows the constant phase relation between the generator and bus-bar voltages. When the frequency is slightly different, the phase relation is always changing. In this case, the moving element of the synchroscope rotates

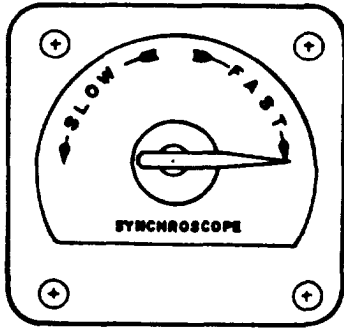

Figure 5-28.—Synchroscope.

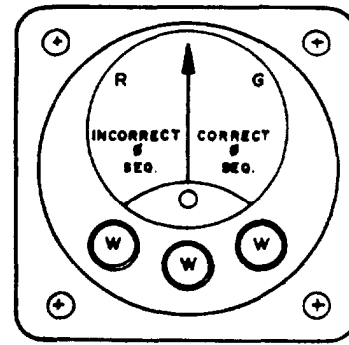

Figure 5-29.—Phase-sequence indicator.

constantly. The speed of rotation is equal to the difference in frequency; the direction shows whether the generator is fast or slow. The generator is placed on line when the pointer slowly approaches a mark. This mark shows that the generator and bus-bar voltages are in phase.

### PHASE-SEQUENCE INDICATORS

The sequence in which the currents of a 3-phase system reach their maximum values is determined by phase-sequence indicators. Figure 5-29 shows an example of this type of indicator.

Gas turbine ships have phase-sequence indicators installed in switchboards which may be connected to shore power. These instruments indicate whether shore power is of correct or incorrect phase sequence before shipboard equipment is connected to shore power. Three-phase motors, when connected to incorrect phase-sequence power, rotate in the opposite direction.

The phase-sequence indicator has three neon lamps that light when all three phases are energized. A meter connected to a network of resistors and condensers shows correct or incorrect sequence on a marked scale.

### MISCELLANEOUS SENSORS

Several of the sensors used in the gas turbine propulsion plant are not pressure or temperature sensors. These devices, such as ice detectors, speed sensors, vibration sensors, and UV flame detectors, are used to monitor or protect the gas turbine plant from damage.

### ICE DETECTOR SYSTEM

Under certain atmospheric conditions, ice can form in the inlet airflow system. This can happen

when the temperature falls below 41°F and the relative humidity is above 70 percent. The formation of ice in the inlet has two detrimental effects. It can restrict airflow to the gas turbine with a resultant loss of power. Also, if allowed to build up in large quantities, ice chunks can break off. They can go through the gas turbine compressor causing foreign object damage (FOD).

The ice detector sensor is located in the lower left corner of the inlet barrier wall. It senses inlet temperature and humidity and transmits proportional electrical signals to the signal conditioner. The signal conditioner is mounted on the underside of the base. It provides a signal for the icing alarm at the propulsion console when icing conditions exist.

### Ice Detectors

The detector shown in figure 5-30 consists of a sensor assembly mounted in a body secured to

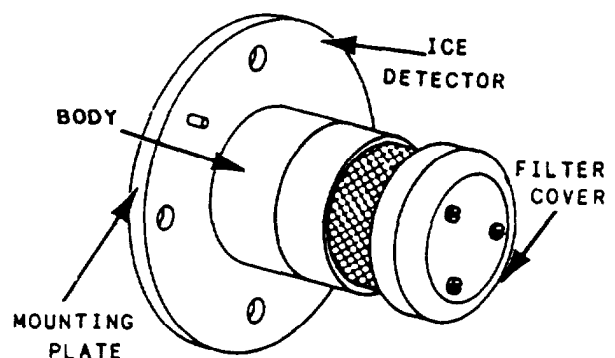

Figure 5-30.—Ice detector.



a mounting plate assembly. The body and mounting plate are machined from stainless steel. A filter cover assembly protects the sensing element while allowing the passage of atmospheric air over two sensors. It consists of a temperature sensor and a humidity sensor. Electrical connection to the sensing element is made through a fixed plug secured to the mounting plate.

Changes in temperature of the air flowing over the sensor assembly vary the electrical resistance of the temperature sensor. As temperature decreases, the resistance of the temperature increases; at 41°F, resistance is about 2.4 kilohms (kΩ). The change in resistance modifies a dc signal in the ice-detector signal conditioner.

Changes in the moisture content of the air flowing over the sensor assembly vary the electrical resistance of the humidity sensor. The humidity sensor is a salt-treated wafer. As it absorbs moisture from the surrounding air, its resistance decreases as the humidity increases; at 70 percent relative humidity, resistance is about 435 kΩ. The change in resistance affects the feedback to an amplifier in the ice-detector signal conditioner.

### Ice-Detector Signal Conditioners

The ice-detector signal conditioner (fig. 5-3 1) is contained in a metal box. The box is attached to the underside of the base/enclosure. It contains two printed-circuit board assemblies, a transformer, and a relay and capacitor. The box is closed by a cover bearing identification labels.

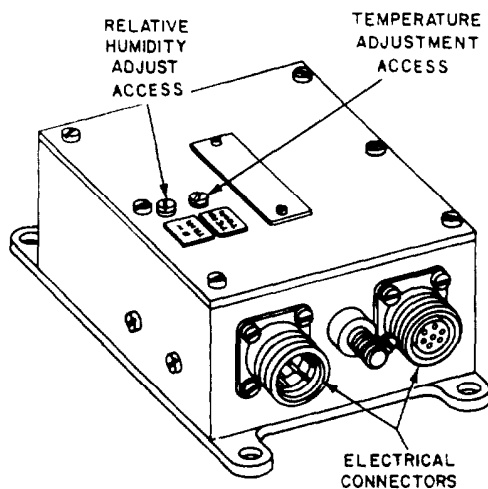

Figure 5-31.—Ice-detector signal conditioner.

The two screws on the top cover access holes to two potentiometers positioned on the upper circuit board assembly.

### SPEED SENSORS

One of the more important parameters sensed in a gas turbine propulsion plant is speed. Speed is measured on reduction gears and gas turbines. The reduction gear speed is monitored to inform the propulsion plant operators of the propeller shaft speed. Gas turbine speed is measured to ensure the turbine does not overspeed. Also, gas turbine speed is used as an input to the control systems of the engine. Two types of speed sensors are used to measure the required speeds. One type is the tachometer generator, used on reduction gears. The other type is the magnetic speed pickup, used to sense gas turbine speeds. In some applications, it is used to sense reduction gear speeds.

#### Tachometer Generators

Main reduction gears (MRGs) use tachometer generators to provide electrical signals for remote indication of propulsion shaft speed. The output of the tachometer generator is voltage pulses proportional to the speed of the propeller shaft. The tachometer signal is amplified. Then it is sent to the propulsion electronics for use in data and bell logging and display of shaft speed. You can find more information on tachometer generator operation by referring to the related technical manual found on your ship.

#### Magnetic Speed Pickup Transducer

The magnetic speed pickup transducer is usually referred to as a magnetic speed pickup and is the most common type of speed sensor found in gas turbine propulsion plants. It is used for sensing gas turbine speed on the LM2500 and the Allison 501-K17. It is also used to measure reduction gear speed for controllable pitch propeller (CPP) systems on the FFG-7 class ships. The MRGs of the DD-963 class ships use magnetic speed pickups for sensing clutch engagement speeds.

Magnetic speed pickups sense speed by using a toothed gear that cuts the magnetic field of the pickup. The output of the sensor is a square-wave ac voltage. This voltage is converted to a proportional dc voltage in a signal conditioner. The output of the signal conditioner is used in

control functions as well as for indications of equipment speed. Figure 5-32 shows the magnetic speed pickup transducer used in an LM2500 power turbine.

The most important thing you should remember when replacing a speed pickup is to check the depth setting. You can measure the depth clearance with either a special tool supplied by the equipment manufacturer or a depth micrometer. Set the proper clearance by using either shims or locknuts. If you do not set the clearance properly, the magnetic sensor will be either too close to the toothed gear or too far from it. If it is too close, it may be damaged by the rotating gear. If it is too far from the gear, the unit will fail to give the proper voltage signal. Always refer to the appropriate manufacturer's technical manual when you replace a magnetic speed sensor.

### VIBRATION SENSORS

One of the first indications of internal damage to gas turbines is high vibration. High-vibration conditions can be indications of failed bearings, damaged blading, or a dirty compressor. The GTEs found on Navy ships use velocity vibration and accelerometer-type pickups. Figure 5-33 shows a typical velocity vibration pickup used on GTEs.

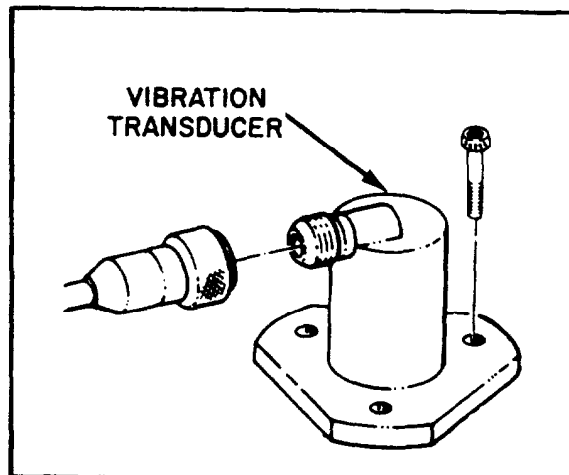

Figure 5-33.—Velocity vibration transducer.

The vibration pickup is a linear velocity transducer (transfers mechanical energy to electrical energy). The magnetic circuit is closed through the circular air gap between the pole piece sleeve in the case and the pole pieces on the magnet assembly. The air gap is interrupted by the coils. (The flux field in the air gap is normally aligned with the approximate midpoint of the two coils by the centering action of the two springs.) As the engine vibrates, the rigidly

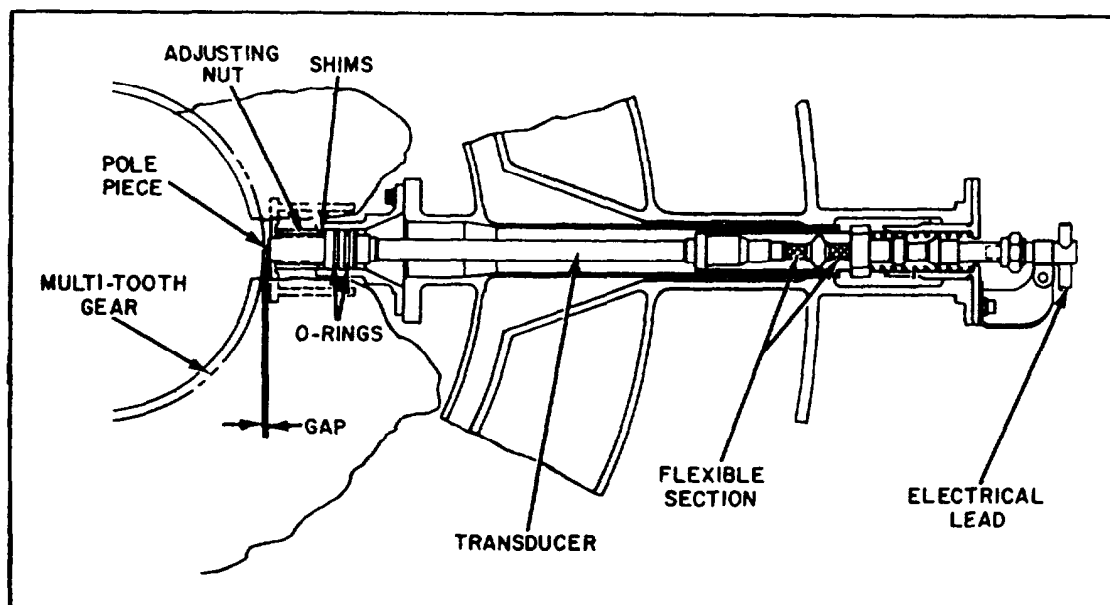

Figure 5-32.—Magnetic speed pickup used on the LM2500 power turbine.

mounted case and coil move with the vibration. Due to its inertia, the magnet assembly remains stationary. The coil windings cut through the magnetic field in the air gap, inducing a voltage in the coils. This voltage is proportional to the velocity of vibration. You may use vibration filters to filter out the frequencies that are transmitted

from sources external to the gas turbine. By the use of these filters, you can narrow the cause of vibration down to one section of an engine. On the LM2500 the power turbine operates at a slower speed than the gas generator. By use of filters, you can determine the location of the engine vibration. You can tell if it is from the

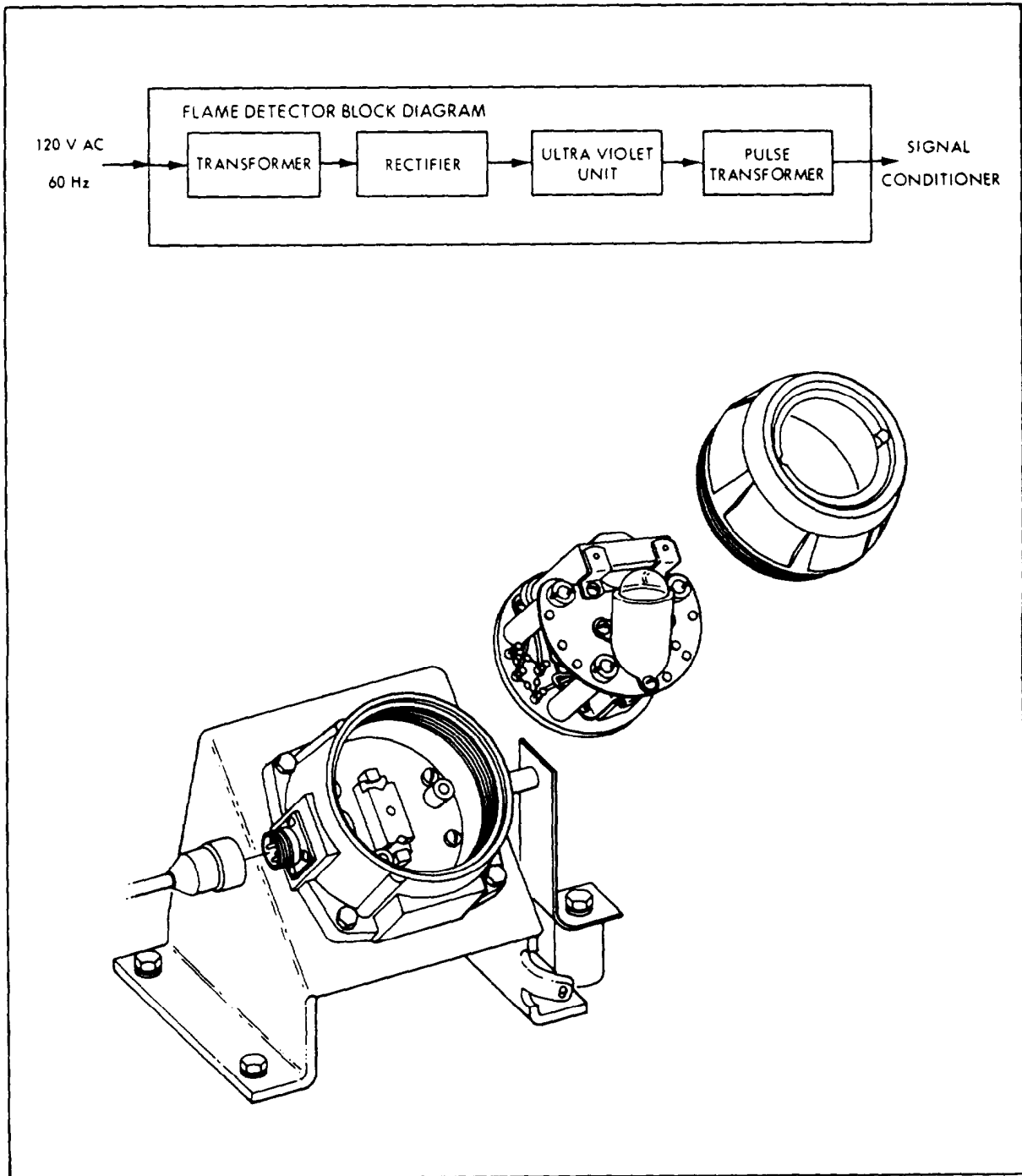

Figure 5-34.—Flame-detector block diagram and typical flame detector.

lower-frequency power turbine or the higher-frequency gas generator.

## ULTRAVIOLET FLAME DETECTOR

Ultraviolet flame detectors are used in GTMs to detect the presence of fire. These sensors are used along with temperature sensors in the LM2500. They are used alone in the Allison 501-K17 for fire protection. The fire detection system alerts the operator of fire in the module. On twin-shaft ships it also activates the fire stop sequence and releases fire-extinguishing agents to extinguish a fire in the Allison 501-K17 module or in the LM2500 module.

### Flame Detector

The flame detector (fig. 5-34) is an electronic tube that responds to UV radiation in ordinary flames. It is insensitive to infrared (IR) and ordinary visible light sources. The tube has two symmetrical electrodes within the gas-filled envelope. It operates on pulsating dc. Alternating

current enters the detector and is stepped up by a transformer. This ac is then rectified to pulsating dc, which is fed to the UV sensor. Ultraviolet light containing wavelengths in the range of 1900 to 2100 angstrom units ionize the gas in the tube. This allows the current to flow through the tube. The current then goes to a pulse transformer which couples it to the signal conditioner.

### Flame-Detector Signal Conditioner

The flame-detector signal conditioner (fig. 5-35) is contained in a metal box. The box is attached to the underside of the base/enclosure of the LM2500. On the Allison 501-K17, the unit is located in the alarm terminal box on the generator end of the module base.

Identical detector cards (one for each UV sensor) are located in the signal conditioner. The detector card amplifies, rectifies, and filters the current pulses from the UV sensor. This provides an output voltage level proportional to the UV light level at the UV sensor.

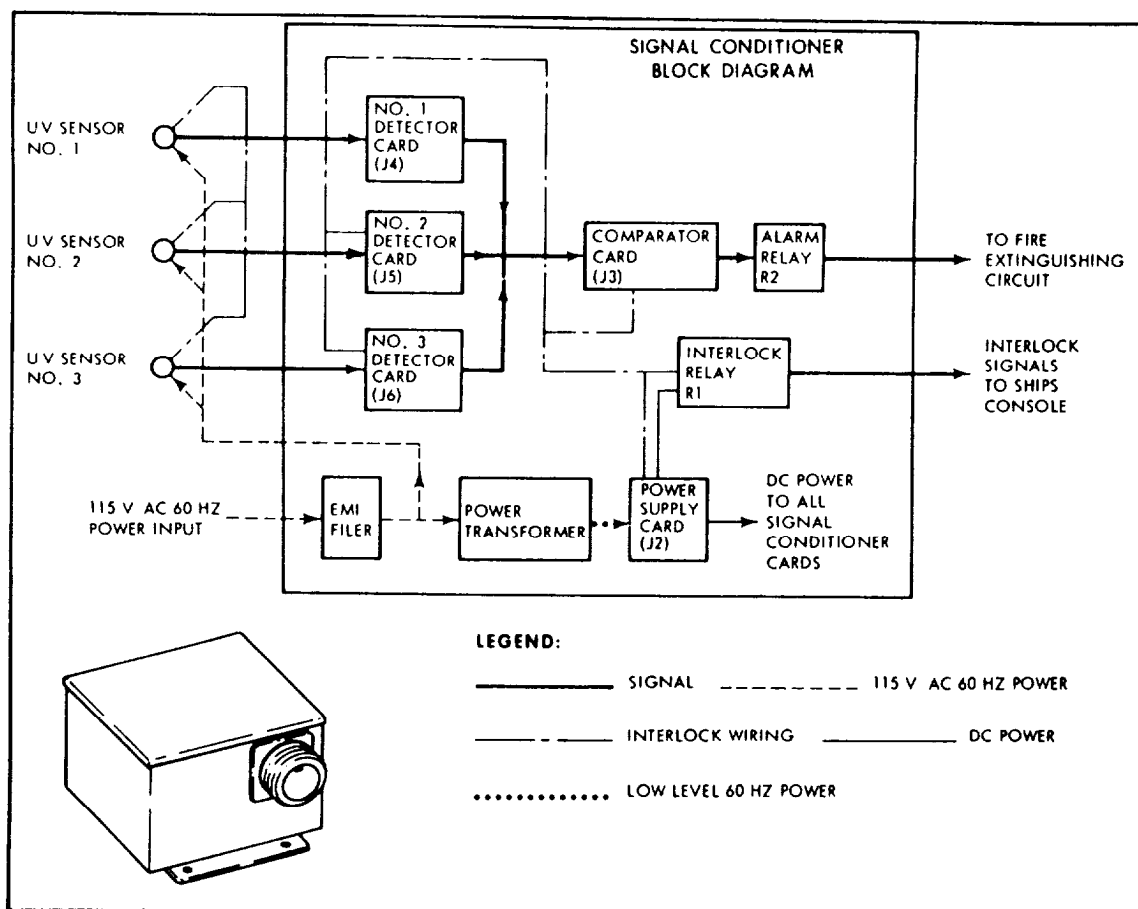

Figure 5-35.—Flame-detector signal conditioner block diagram and typical signal conditioner unit.

## **SUMMARY**

In this chapter we introduced you to many of the sensing and indicating devices found on gas turbine ships. Only the most common and frequently used devices were

covered. You may come across other types of specialized sensors or indicating instruments not covered in this chapter. If you have any questions on indicating instruments, always refer to the appropriate manufacturer's technical manual.

## CHAPTER 6

# PIPING SYSTEM COMPONENTS

As a GSE3 or GSM3, some portion of your daily routine will involve working with valves, steam traps, filters and strainers, heat exchangers, piping, gasket and packing materials, fasteners, and insulation. You will be responsible for routine maintenance of this equipment in your spaces and possibly throughout the ship. The machinery of a system cannot work properly unless the piping system components that make up that system are in good working order. The information in this chapter, as it is throughout the book, is of a broad and general nature. You should refer to the appropriate manufacturer's technical manuals and/or ship's plans, information books, and plant or valve manuals for specific problems with individual equipment.

After studying this chapter, you should have the knowledge to be able to (1) identify, maintain, and repair the various types of manually, mechanically, remotely, electrically, and pneumatically operated valves common to the gas turbine propelled class ships; the various types of steam traps common in the waste heat systems; the various types of strainers and filters used in the ships' fuel oil, lube oil, hydraulic oil, and air systems; the various types of heat exchangers used in ships' auxiliary systems; the various types of piping, tubing, and hose assemblies; and the various fittings, unions, joints, supports, hangers, and safety shields used with the above components; (2) identify, select, and properly use gaskets, packing material, and O-rings used for repair and maintenance; (3) identify, inspect, and select the correct fasteners used for securing the components of various piping systems or valves; and (4) select and install the correct insulation materials used in today's modern naval ship systems.

### VALVES

A valve is any device used for the control of fluids in a closed system. In this section we will

discuss valve construction and the most common types of valves you will use in the day-to-day operation and maintenance of the various ship-board engineering systems. Valves are typed or classified according to their use in a system.

### VALVE CONSTRUCTION

Valves are usually made of bronze, brass, cast or malleable iron, or steel. Steel valves are either cast or forged and are made of either plain steel or alloy steel. Alloy steel valves are used in high-pressure, high-temperature systems; the disks and seats (internal sealing surfaces) of these valves are usually surfaced with a chromium-cobalt alloy known as Stellite. Stellite is extremely hard.

Brass and bronze valves are never used in systems where temperatures exceed 550°F. Steel valves are used for all services above 550°F and in lower temperature systems where internal or external conditions of high pressure, vibration, or shock would be too severe for valves made of brass or bronze. Bronze valves are used almost exclusively in systems that carry salt water. The seats and disks of these valves are usually made of Monel, a metal that has excellent corrosion- and erosion-resistant qualities.

Most submarine seawater valves are made of an alloy of 70 percent copper to 30 percent nickel (70/30).

### VALVE TYPES

Although many different types of valves are used to control the flow of fluids, the basic valve types can be divided into two general groups: stop valves and check valves.

Besides the basic types of valves, many special valves, which cannot really be classified as either stop valves or check valves, are found in the engineering spaces. Many of these valves serve to control the pressure of fluids and are known as pressure-control valves. Other valves are identified by names that indicate their general function, such

as thermostatic recirculating valves. The following sections deal first with the basic types of stop valves and check valves, then with some of the more complicated special valves.

### Stop Valves

Stop valves are used to shut off or, in some cases, partially shut off the flow of fluid. Stop valves are controlled by the movement of the valve stem. Stop valves can be divided into four general categories: globe, gate, butterfly, and ball valves. Plug valves and needle valves may also be considered stop valves. Since plug valves and needle valves are covered sufficiently in *Fireman, NAVEDTRA 10520*, we will not discuss them in this manual.

**GLOBE VALVES.**—Globe valves are probably the most common valves in existence. The globe valve derives its name from the globular shape of the valve body. However, positive identification of a globe valve must be made internally because other valve types may have globular appearing bodies. Globe valve inlet and outlet openings are arranged in several ways to suit varying requirements of flow. Figure 6-1 shows the common types of globe valve bodies; straight-flow, angle-flow, and cross-flow. Globe valves are used extensively throughout the engineering plant and other parts of the ship in a variety of systems.

**GATE VALVES.**—Gate valves are used when a straight-line flow of fluid and minimum

restriction is desired. Gate valves are so named because the part which either stops or allows flow through the valve acts somewhat like the opening or closing of a gate and is called, appropriately, the gate. The gate is usually wedge shaped. When the valve is wide open, the gate is fully drawn up into the valve, leaving an opening for flow through the valve the same size as the pipe in which the valve is installed. Therefore, there is little pressure drop or flow restriction through the valve. Gate valves are not suitable for throttling purposes since the control of flow would be difficult due to valve design and since the flow of fluid slapping against a partially open gate can cause extensive damage to the valve. Except as specifically authorized, gate valves should not be used for throttling.

Gate valves are classified as either **RISING-STEM** or **NONRISING-STEM** valves. On the nonrising-stem gate valve shown in figure 6-2, the stem is threaded on the lower end into the gate. As the handwheel on the stem is rotated, the gate travels up or down the stem on the threads, while the stem remains vertically stationary. This type of valve almost always has a pointer-type indicator threaded onto the upper end of the stem to indicate valve position.

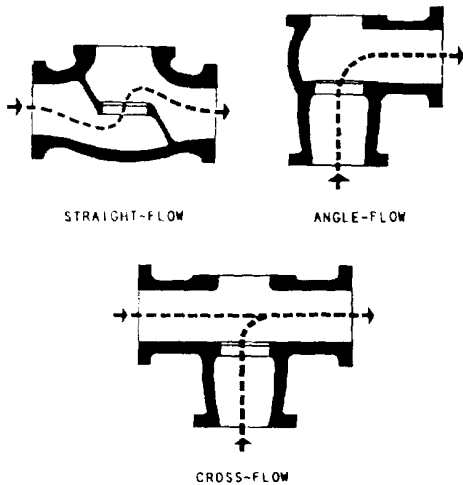

Figure 6-1.—Types of globe valve bodies.

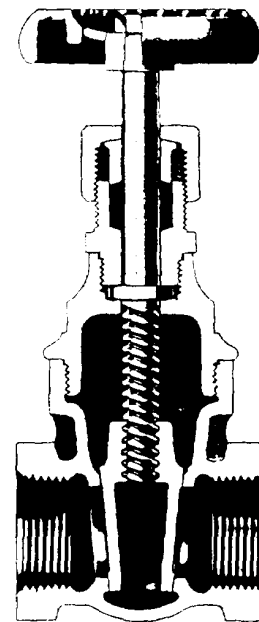

Figure 6-2.—Cutaway view of a gate valve (nonrising-stem type).

The rising-stem gate valve, shown in figure 6-3, has the stem attached to the gate; the gate and stem rise and lower together as the valve is operated.

Gate valves used in steam systems have flexible gates. The reason for using a flexible gate is to prevent binding of the gate within the valve when the valve is in the closed position. When steam lines are heated, they will expand, causing some distortion of valve bodies. If a solid gate fits snugly between the seat of a valve in a cold steam system, when the system is heated and pipes elongate, the seats will compress against the gate, wedging the gate between them and clamping the valve shut. This problem is overcome by use of a flexible gate (two circular plates attached to each other with a flexible hub in the middle). This design allows the gate to flex as the valve seat compresses it, thereby preventing clamping.

**BUTTERFLY VALVES.**—The butterfly valve, one type of which is shown in figure 6-4, may be used in a variety of systems aboard ship. These valves can be used effectively in freshwater, saltwater, JP-5, F-76 (naval distillate), lube oil, and chill water systems aboard ship. The butterfly

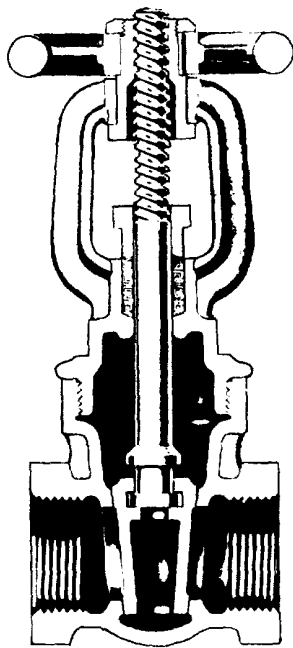

Figure 6-3.—Cutaway view of a gate valve (rising-stem type).

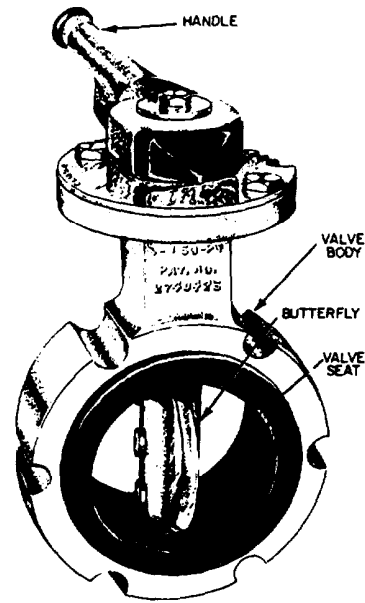

Figure 6-4.—Butterfly valve.

valve is light in weight, relatively small, relatively quick-acting, provides positive shut-off, and can be used for throttling.

The butterfly valve has a body, a resilient seat, a butterfly disk, a stem, packing, a notched positioning plate, and a handle. The resilient seat is under compression when it is mounted in the valve body, thus making a seal around the periphery of the disk and both upper and lower points where the stem passes through the seat. Packing is provided to form a positive seal around the stem for added protection in case the seal formed by the seat should become damaged.

To close or open a butterfly valve, turn the handle only one quarter turn to rotate the disk 90°. Some larger butterfly valves may have a handwheel that operates through a gearing arrangement to operate the valve. This method is used especially where space limitation prevents use of a long handle.

Butterfly valves are relatively easy to maintain. The resilient seat is held in place by mechanical means, and neither bonding nor cementing is necessary. Because the seat is replaceable, the valve seat does not require lapping, grinding, or machine work.

**BALL VALVES.**—Ball valves, as the name implies, are stop valves that use a ball to stop or



start the flow of fluid. The ball (fig. 6-5) performs the same function as the disk in the globe valve. When the valve handle is operated to open the valve, the ball rotates to a point where the hole through the ball is in line with the valve body inlet and outlet. When the valve is shut, which requires only a 90° rotation of the handwheel for most valves, the ball is rotated so the hole is perpendicular to the flow openings of the valve body, and flow is stopped.

Most ball valves are of the quick-acting type (requiring only a 90° turn to operate the valve either completely open or closed), but many are planetary gear operated. This type of gearing allows the use of a relatively small handwheel and operating force to operate a fairly large valve. The gearing does, however, increase the operating time for the valve. Some ball valves contain a swing check located within the ball to give the valve a check valve feature. Ball valves are normally found in the following systems aboard ship: seawater, sanitary, trim and drain, air, hydraulic, and oil transfer.

### Check Valves

Check valves are used to allow fluid flow in a system in only one direction. They are operated by the flow of fluid in the piping. A check valve may be of the swing type, lift type, or ball type.

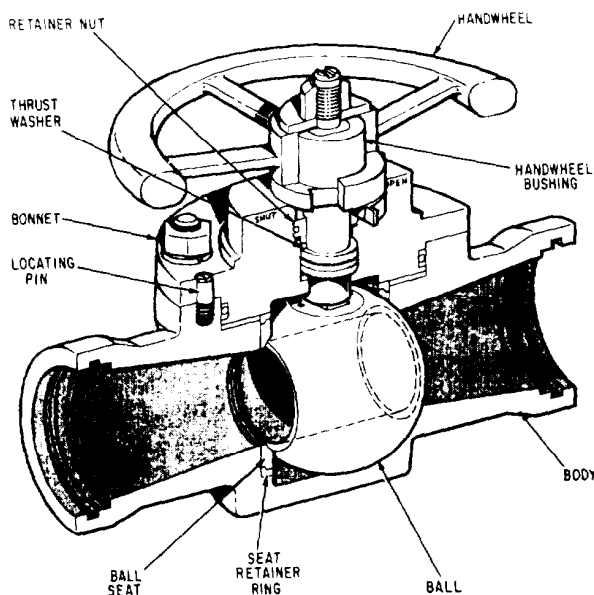

Figure 6-5.—Typical seawater ball valve.

As we have seen, most valves can be classified as being either stop valves or check valves. Some valves, however, function either as stop valves or as check valves—depending on the position of the valve stem. These valves are known as STOP-CHECK VALVES.

A stop-check valve is shown in cross section in figure 6-6. This type of valve looks very much like a lift-check valve. However, the valve stem is long enough so when it is screwed all the way down it holds the disk firmly against the seat, thus preventing any flow of fluid. In this position, the valve acts as a stop valve. When the stem is raised, the disk can be opened by pressure on the inlet side. In this position, the valve acts as a check valve, allowing the flow of fluid in only one direction. The maximum lift of the disk is controlled by the position of the valve stem. Therefore, the position of the valve stem limits the amount of fluid passing through the valve even when the valve is operating as a check valve.

Stop-check valves are widely used throughout the engineering plant. Stop-check valves are

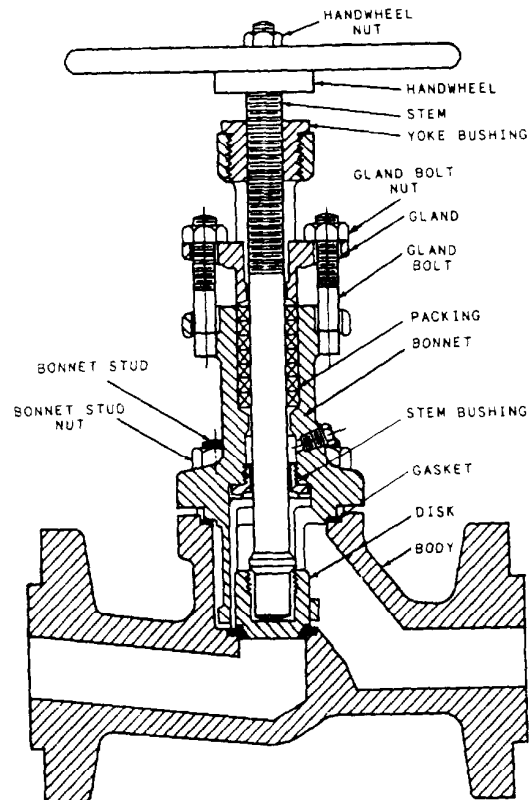

Figure 6-6.—Stop-check valve.

used in many drain lines and on the discharge side of many pumps.

### Special-Purpose Valves

There are many types of automatic pressure control valves. Some of them merely provide an escape for pressures exceeding the normal pressure; some provide only for the reduction of pressure; and some provide for the regulation of pressure.

**RELIEF VALVES.**—Relief valves are automatic valves used on system lines and equipment to prevent overpressurization. Most relief valves simply lift (open) at a preset pressure and reset (shut) when the pressure drops only slightly below the lifting pressure. Figure 6-7 shows a relief valve of this type. System pressure simply acts under the valve disk at the inlet of the valve. When system pressure exceeds the force exerted by the valve spring, the valve disk lifts off its seat, allowing some of the system fluid to escape through the valve outlet until system pressure is reduced to just below the relief set point of the valve. The spring then reseats the valve. An operating lever is provided to allow manual cycling of the relief valve or to gag it open for certain tests. Virtually all relief valves are provided with some type of device to allow manual cycling.

Other types of relief valves are the high-pressure (HP) air safety relief valve and the bleed air surge relief valve. Both of these types of valves are designed to open completely at a specified lift

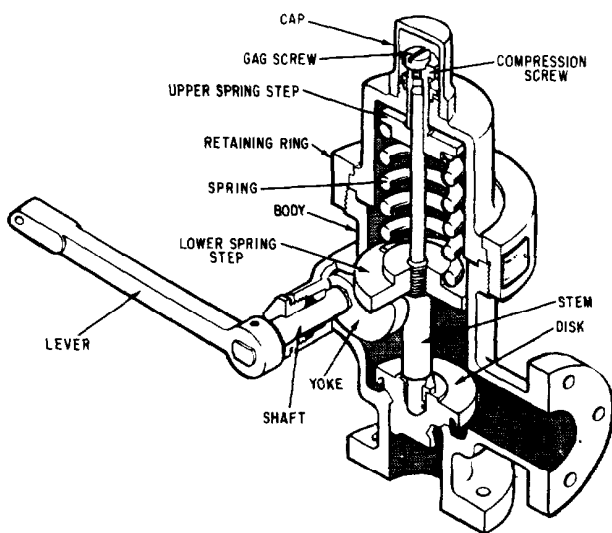

Figure 6-7.—Typical relief valve.

pressure and to remain open until a specific reset pressure is reached-at which time they shut. Many different designs of these valves are used, but the same result is achieved.

**SPRING-LOADED REDUCING VALVES.**—Spring-loaded reducing valves, one type of which is shown in figure 6-8, are used in a wide variety of applications. Low-pressure air reducers and others are of this type. The valve simply uses spring pressure against a diaphragm to open the valve. On the bottom of the diaphragm, the outlet pressure (the pressure in the reduced pressure system) of the valve forces the disk upward to shut the valve. When the outlet pressure drops below the set point of the valve, the spring pressure overcomes the outlet pressure and forces the valve stem downward, opening the valve. As the outlet pressure increases, approaching the desired value, the pressure under the diaphragm begins to overcome spring pressure, forcing the valve stem upwards, shutting the valve. You can adjust the downstream pressure by removing the valve cap and turning the adjusting screw, which varies the spring pressure against the diaphragm. This particular

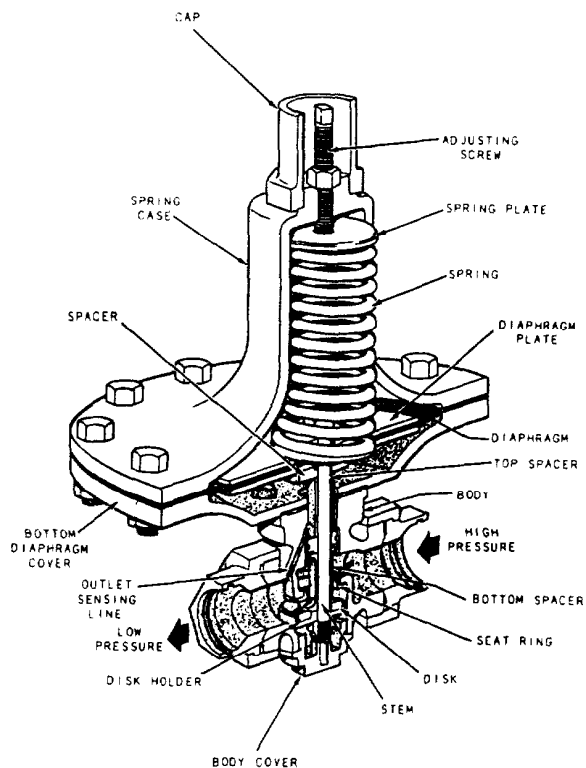

Figure 6-8.—Pressure-reducing (spring-loaded) valve.

spring-loaded valve will fail in the open position if a diaphragm rupture occurs.

**REMOTE-OPERATED VALVES.**—Remote operating gear is installed to provide a means of operating certain valves from distant stations. Remote operating gear may be mechanical, hydraulic, pneumatic, or electric.

Some remote operating gear for valves is used in the normal operation of valves. For example, the main drain system manual valves are opened and closed by a reach rod or a series of reach rods and gears. Reach rods may be used to operate engine-room valves in instances where the valves are difficult to reach from the operating stations.

Other remote operating gear is installed as emergency equipment. Some of the main drain

and almost all of the secondary drain system valves are equipped with remote operating gears. You can operate these valves locally, or in an emergency, you can operate them from remote stations. Remote operating gear also includes a valve position indicator to show whether the valve is open or closed.

**PRESSURE-REDUCING VALVES.**—Pressure-reducing valves are automatic valves that provide a steady pressure into a system that is at a lower pressure than the supply system. Reducing valves of one type or another are found, for example, in firemain, seawater, and other systems. A reducing valve can normally be set for any desired downstream pressure within the design limits of the valve. Once the valve is set, the reduced pressure will be maintained regardless of

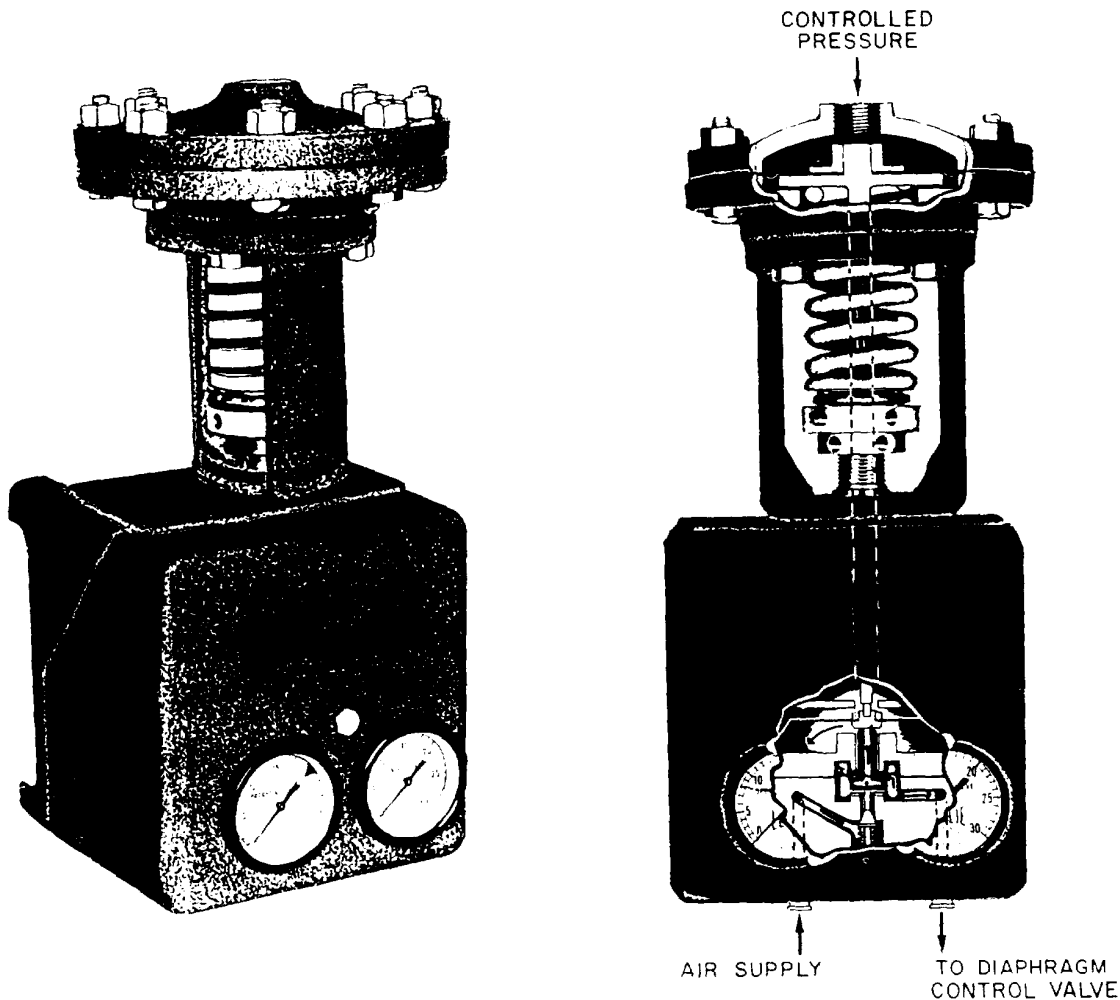

Figure 6-9.—Air-operated control pilot.

changes in the supply pressure (as long as the supply pressure is at least as high as the reduced pressure desired) and regardless of the amount of reduced pressure fluid that is used.

Various designs of pressure-reducing valves are in use. Two of the types most commonly found on gas turbine ships are the spring-loaded reducing valve (already discussed) and the air-pilot operated diaphragm reducing valve.

Air-pilot operated diaphragm control valves are used extensively on naval ships. The valves and pilots are available in several designs to meet different requirements. They may be used to reduce pressure, to increase pressure, as unloading valves, or to provide continuous regulation of pressure. Valves and pilots of very similar design can also be used for other services, such as liquid-level control and temperature control.

The air-operated control pilot may be either direct acting or reverse acting. A direct-acting, air-operated control pilot is shown in figure 6-9. In this type of pilot, the controlled pressure—that is, the pressure from the discharge side of the diaphragm control valve—acts on top of a diaphragm in the control pilot. This pressure is balanced by the pressure exerted by the pilot adjusting spring. If the controlled pressure increases and overcomes the pressure exerted by the pilot adjusting spring, the pilot valve stem is forced downward. This action causes the pilot

valve to open, thereby increasing the amount of operating air pressure going from the pilot to the diaphragm control valve. A reverse-acting pilot has a lever that reverses the pilot action. In a reverse-acting pilot, therefore, an increase in controlled pressure produces a decrease in operating air pressure.

In the diaphragm control valve, operating air from the pilot acts on the valve diaphragm. The superstructure, which contains the diaphragm, is direct acting in some valves and reverse acting in others. If the superstructure is direct acting, the operating air pressure from the control pilot is applied to the TOP of the valve diaphragm. If the superstructure is reverse acting, the operating air pressure from the pilot is applied to the UNDERSIDE of the valve diaphragm.

Figure 6-10 shows a very simple type of direct-acting diaphragm control valve with operating air pressure from the control pilot applied to the top of the valve diaphragm. Since the valve in the figure is a downward seating valve, any increase in operating air pressure pushes the valve stem downward toward the closed position.

Now look at figure 6-11. This is also a direct-acting valve with operating air pressure from the control pilot applied to the top of the

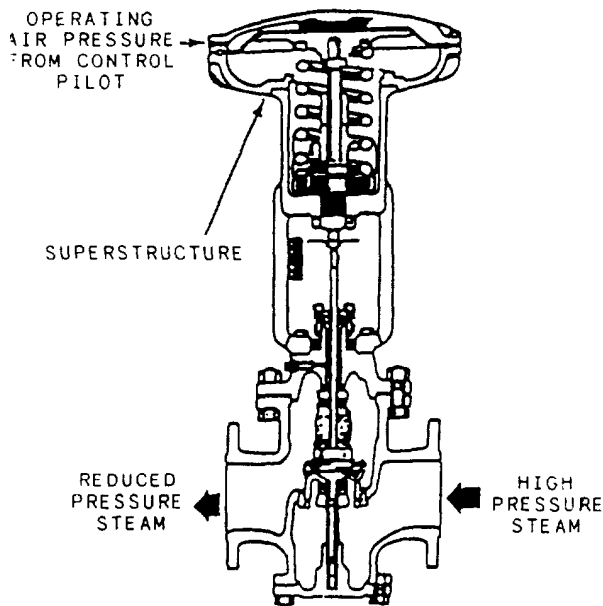

Figure 6-10.—Diaphragm control valve, downward-seating type.

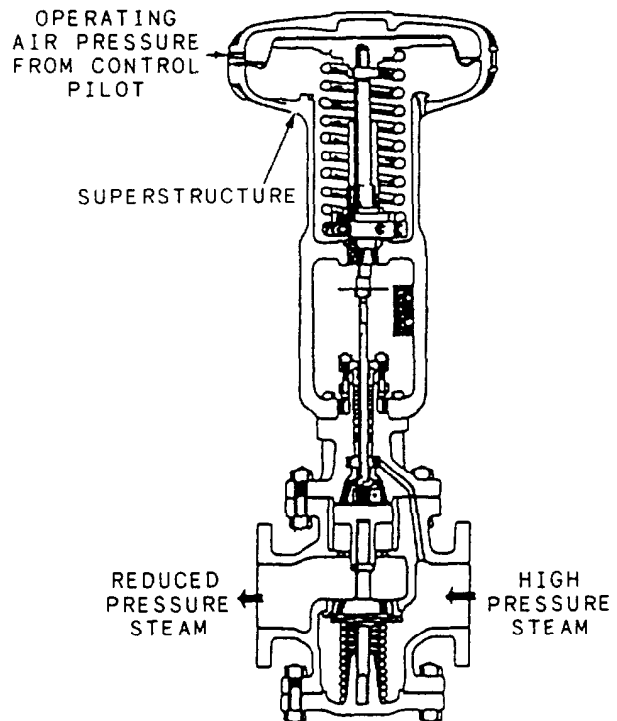

Figure 6-11.—Diaphragm control valve, upward-seating type.

valve diaphragm. Note that the valve shown in figure 6-11 is more complicated than the one shown in figure 6-10 because of the added springs under the seat. The valve shown in figure 6-11 is an upward seating valve rather than a downward seating valve. Therefore, any increase in operating air pressure from the control pilot tends to OPEN this valve rather than to close it.

As you have seen, the air-operated control pilot may be either direct acting or reverse acting. The superstructure of the diaphragm control valve may be either direct acting or reverse acting. And, the diaphragm control valve may be either upward seating or downward seating. These three factors, as well as the purpose of the installation, determine how the diaphragm control valve and its air-operated control pilot are installed in relation to each other.

To see how these factors are related, let's consider an installation in which a diaphragm control valve and its air-operated control pilot are used to supply controlled-steam pressure.

Figure 6-12 shows one arrangement that you might use. Assume that the service requirements indicate the need for a direct-acting, upward-seating diaphragm control valve. Can you figure out which kind of a control pilot—direct acting or reverse acting—should be used in this installation?

Try it first with a direct-acting control pilot. As the controlled pressure (discharge pressure from the diaphragm control valve) increases, increased pressure is applied to the diaphragm of the direct-acting control pilot. The valve stem is

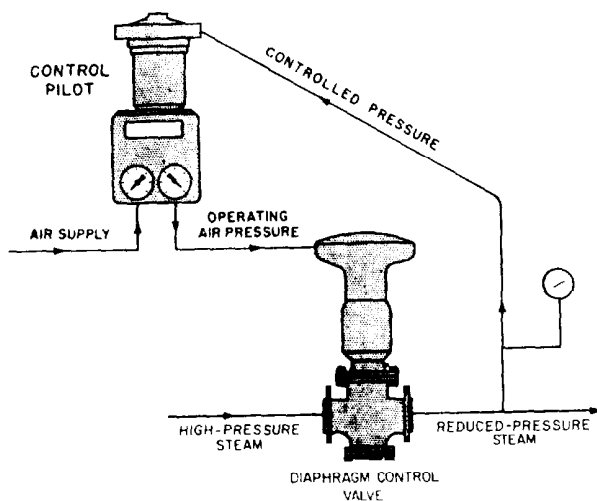
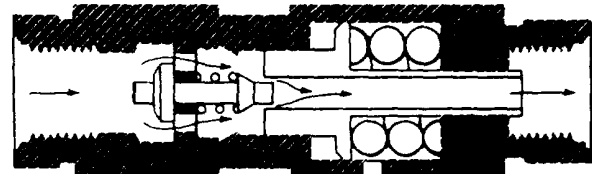

Figure 6-12.—Arrangement of control pilot and diaphragm control valve for supplying reduced-steam pressure.

pushed downward and the valve in the control pilot is opened. This increases the operating air pressure from the control pilot to the top of the diaphragm control valve. The increased operating air pressure acting on the diaphragm of the valve pushes the stem downward, and since this is an upward seating valve, this action OPENS the diaphragm control valve still wider. Obviously, this won't work for this application. An INCREASE in controlled pressure must result in a DECREASE in operating air pressure. Therefore, we made a mistake in choosing the direct-acting control pilot. For this particular pressure-reducing application, you should choose a REVERSE-ACTING control pilot.

It is not likely that you will be required to decide which type of control pilot and diaphragm control valve is needed in any particular installation. But you must know how and why they are selected so you do not make mistakes in repairing or replacing these units.

**PRIORITY VALVES.**—In systems with two or more circuits, it is sometimes necessary to have some means of supplying all available fluid to one particular circuit in case of a pressure drop in the system. A priority valve is often incorporated in the system to ensure a supply of fluid to the critical/vital circuit. The components of the system are arranged so the fluid to operate each circuit, except the one critical/vital circuit, must



A. PRIORITY FLOW

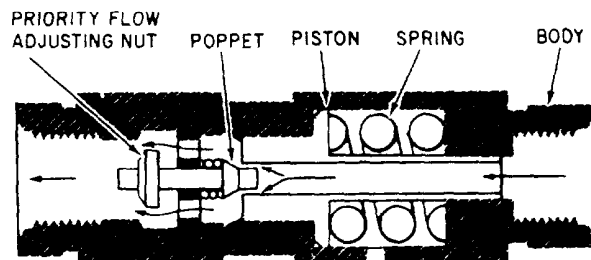

B. FREE FLOW

Figure 6-13.—Priority valve.

flow through the priority valve. A priority valve may also be used within a subsystem containing two or more actuating units to ensure a supply of fluid to one of the actuating units. In this case, the priority valve is incorporated in the subsystem in such a location that the fluid to each actuating unit, except the critical/vital unit, must flow through the valve.

Figure 6-13 shows one type of priority valve. View A of figure 6-13 shows the valve in the priority-flow position; that is, the fluid must flow through the valve in the direction shown by the arrows to get to the noncritical/vital circuits or actuating units. With no fluid pressure in the valve, spring tension forces the piston against the stop and the poppet seats against the hole in the center of the piston. As fluid pressure increases, the spring compresses and the piston moves to the right. The poppet follows the piston, seating the hole in the center of the piston until the preset pressure is reached. (The preset pressure depends upon the requirements of the system and is set by the manufacturer.) Assume that the

critical/vital circuit or actuating unit requires 1500 psi. When the pressure in the valve reaches 1500 psi, the poppet reaches the end of its travel. As the pressure increases, the piston continues to move to the right, which unseats the poppet and allows flow through the valve, as shown in view A of figure 6-13. If the pressure drops below 1500 psi, the compressed spring forces the piston to the left, the poppet seats, and flow through the valve stops.

Figure 6-13, view B, shows the priority valve in the free-flow position. The flow of fluid moves the poppet to the left, the poppet spring compresses, and the poppet unseats. This allows free flow of fluid through the valve.

### VALVE MANIFOLDS

Sometimes suction must be taken from one of many sources and discharged to another unit or units of either the same or another group. A valve manifold is used for this type of operation. An example of such a manifold (fig. 6-14) is the fuel

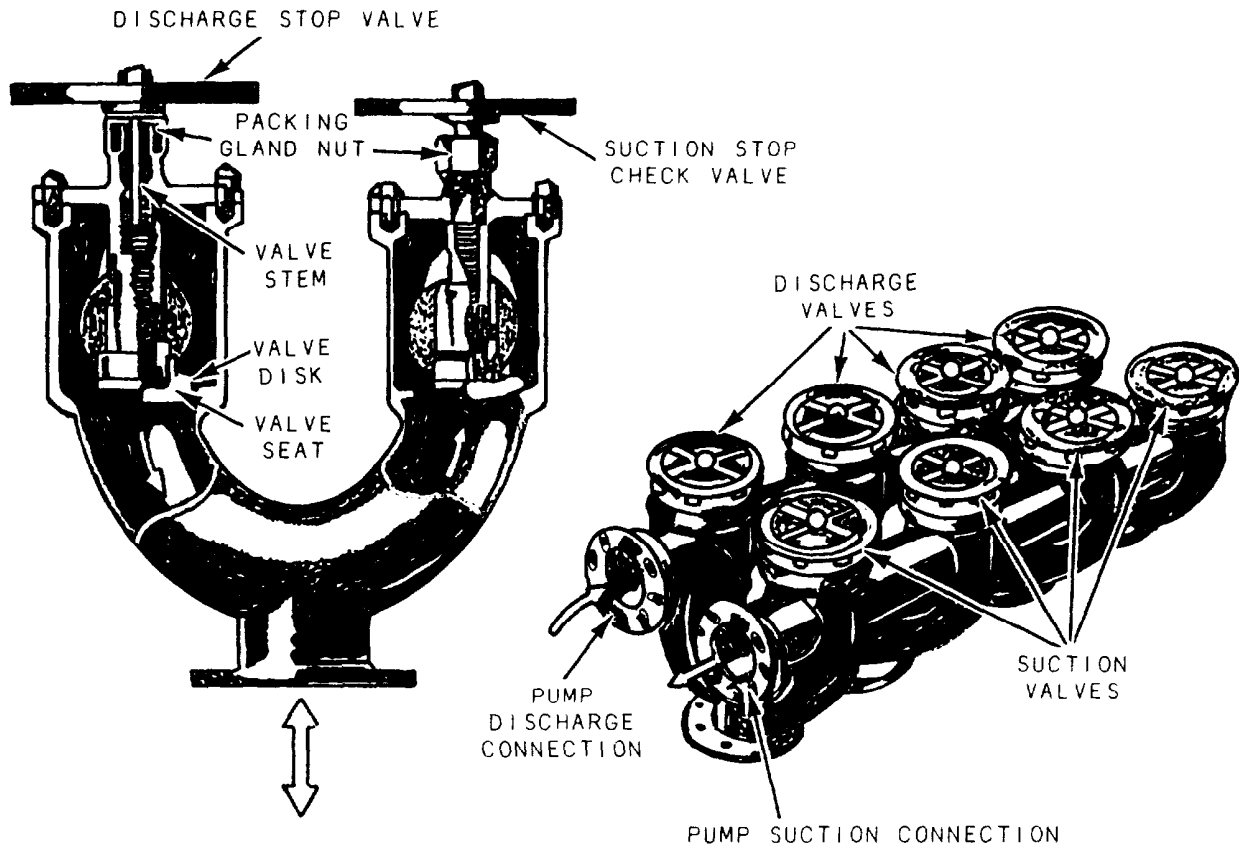

Figure 6-14.—Valve manifold showing cutaway view of the valves and typical combination of suction and discharge valves.

oil filling and transfer system where provision must be made for the transfer of oil from any tank to any other tank, to the service system, or to another ship. If, for example, the purpose is to transfer oil from tank No. 1 to tank No. 4, the discharge valve for tank No. 4 and the suction valve from tank No. 1 are opened, and all other valves are closed. Fuel oil can now flow from tank No. 1, through the suction line, through the pump, through the discharge valve, and into tank No. 4. The manifold suction valves are often of the stop-check type to prevent draining of pumps when they are stopped.

**VALVE HANDWHEEL IDENTIFICATION AND COLOR CODING**

Valves are identified by markings inscribed on the rims of the handwheels, by a circular label plate secured by the handwheel nut, or by label plates attached to the ship’s structure or to the adjacent piping.

Piping system valve handwheels and operating levers are marked for training and casualty control purposes with a standardized color code. Color code identification is in conformance with the color scheme of table 6-1. Implementation of this color scheme provides uniformity among all naval surface ships and shore-based training facilities.

**MAINTENANCE**

Preventive maintenance is the best way to extend the life of valves and fittings. Always refer to the applicable portion of the *Standard Navy Valve Technical Manual*, NAV-SEA 0948-LP-012-5000, if possible. When making repairs on more sophisticated valve types, use the available manufacturer’s technical manuals. As soon as you observe a leak, determine the cause, and then apply the proper corrective maintenance. Maintenance may be as simple as tightening a packing nut or gland. A leaking flange joint may need only to have the bolts tightened or to have a new gasket or O-ring inserted. Dirt and scale, if allowed to collect, will cause leakage. Loose hangers permit sections of a line to sag, and the weight of the pipe and the fluid in these sagging sections may strain joints to the point of leakage.

Whenever you are going to install a valve, be sure you know the function the valve is going to perform—that is, whether it must start flow, stop flow, regulate flow, regulate pressure, or prevent backflow. Inspect the valve body for the information that is stamped upon it by the

**Table 6-1.—Valve Handwheel Color Code**

| <u>FLUID</u>       | <u>VALVE HANDWHEEL &amp; OPERATING LEVER</u> |
|--------------------|--|
| STEAM.....         | WHITE  |
| POTABLE-WATER..... | DARK BLUE                                    |
| NITROGEN.....      | LIGHT GRAY                                   |
| HP AIR .....       | DARK GRAY                                    |
| LP AIR.....        | TAN  |
| OXYGEN .....       | LIGHT GREEN                                  |
| SALT WATER .....   | DARK GREEN                                   |
| JP-5.....          | PURPLE                                       |
| FUEL OIL .....     | YELLOW                                       |
| LUBE OIL .....     | STRIPED YELLOW/BLACK                         |
| FIRE PLUGS .....   | RED  |
| FOAM DISCHARGE ... | STRIPED RED/GREEN                            |
| GASOLINE .....     | YELLOW                                       |
| FEEDWATER .....    | LIGHT BLUE                                   |
| HYDRAULIC .....    | ORANGE                                       |
| HYDROGEN.....      | CHARTREUSE                                   |
| HELIUM .....       | BUFF   |
| HELIUM/OXYGEN .... | STRIPED BUFF/GREEN                           |
| SEWAGE .....       | GOLD   |

manufacturer: type of system (oil, water, gas), operating pressure, direction of flow, and other information.

You should also know the operating characteristics of the valve, the metal from which it is made, and the type of end connection with which it is fitted. Operating characteristics and the material are factors that affect the length and kind of service that a valve will give; end connections indicate whether or not a particular valve is suited to the installation.

When you install valves, ensure they are readily accessible and allow enough headroom for full operation. Install valves with stems pointing upward if possible. A stem position between straight up and horizontal is acceptable, but avoid the inverted position (stem pointing downward). If the valve is installed with the stem pointing downward, sediment will collect in the bonnet and score the stem. Also, in a line that is subject to freezing temperatures, liquid that is trapped in the valve bonnet may freeze and rupture it.

Since you can install a globe valve with pressure either above the disk or below the disk (depending on which method will be best for the operation, protection, maintenance, and repair of the machinery served by the system), you should use caution. The question of what would happen if the disk became detached from the stem is a major consideration in determining whether pressure should be above the disk or below it. If you are required to install a globe valve, be SURE to check the blueprints for the system to see which way the valve must be installed. Very serious casualties can result if a valve is installed with pressure above the disk when it should be below the disk, or below the disk when it should be above.

Valves that have been in constant service for a long time will eventually require gland tightening, repacking, or a complete overhaul of all parts. If you know that a valve is not doing the job for which it was intended, dismantle the valve and inspect all parts. You must repair or replace all defective parts.

The repair of globe valves (other than routine renewal of packing) is limited to refinishing the

seat and/or disk surface. When doing this work, you should observe the following precautions:

- When refinishing the valve seat, do not remove more material than is necessary. You can finish valves that do not have replaceable valve seats only a limited number of times.
- Before doing any repair to the seat and disk of a globe valve, check the valve disk to make certain it is secured rigidly to and is square on the valve stem. Also, check to be sure that the stem is straight. If the stem is not straight, the valve disk cannot seat properly.
- Carefully inspect the valve seat and valve disk for evidence of wear, for cuts on the seating area, and for improper fit of the disk to the seat. Even if the disk and seat appear to be in good condition, you should perform a spot-in check to find out whether they actually are in good condition.

Figure 6-15 shows a standard checkoff diagram for performing a routine inspection and minor maintenance of a valve.

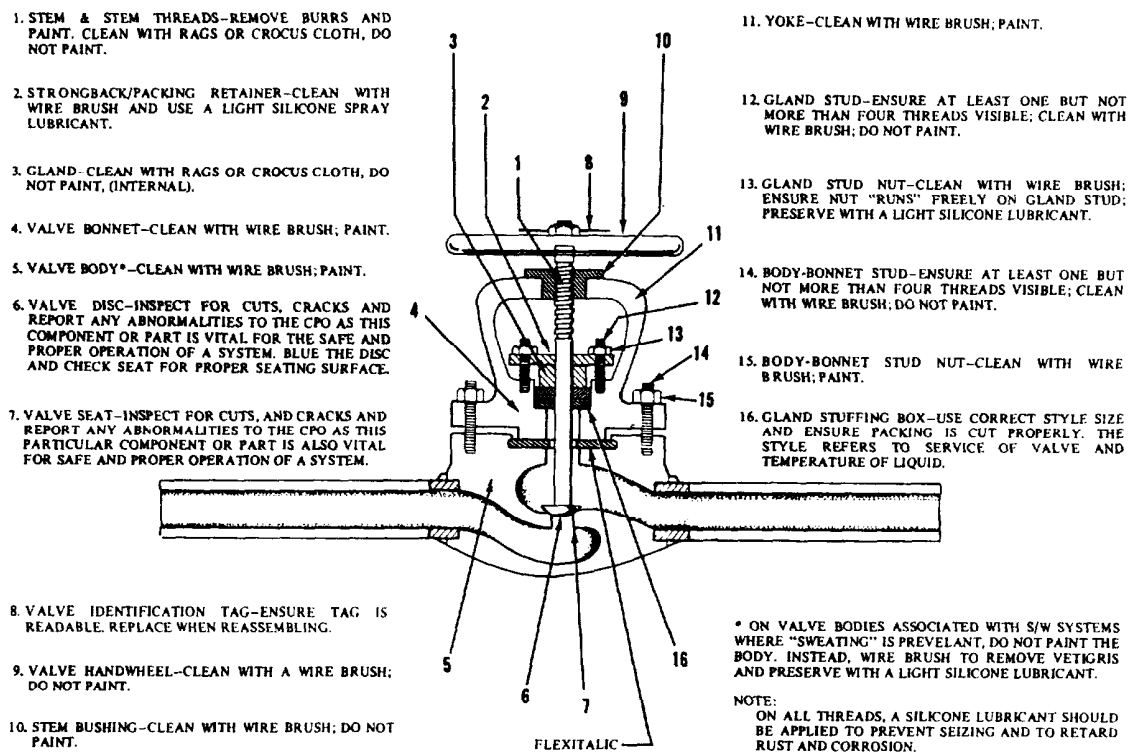

Figure 6-15—Valve maintenance checkoff diagram.



## Spotting-In Valves

The method used to visually determine whether the seat and the disk of a valve make good contact with each other is called spotting-in. To spot-in a valve seat, you first apply a thin coating of Prussian blue (commonly called Blue Dykem) evenly over the entire machined face surface of the disk. Insert the disk into the valve and rotate it one-quarter turn, using a light downward pressure. The Prussian blue will adhere to the valve seat at those points where the disk makes contact. Figure 6-16 shows the appearance of a correct seat when it is spotted-in; it also shows the appearance of various kinds of imperfect seats.

After you have noted the condition of the seat surface, wipe all the Prussian blue off the disk surface. Apply a thin, even coat of Prussian blue to the contact face of the seat and place the disk on the valve seat again and rotate the disk one-quarter turn. Examine the resulting blue ring on the valve disk. The ring should be unbroken and of uniform width. If the blue ring is broken in any way, the disk is not making proper contact with the seat.

## Grinding-In Valves

The manual process used to remove small irregularities by grinding together the contact surfaces of the seat and disk is called grinding-in. Grinding-in should not be confused with refacing processes in which lathes, valve reseating machines, or power grinders are used to recondition the seating surfaces.

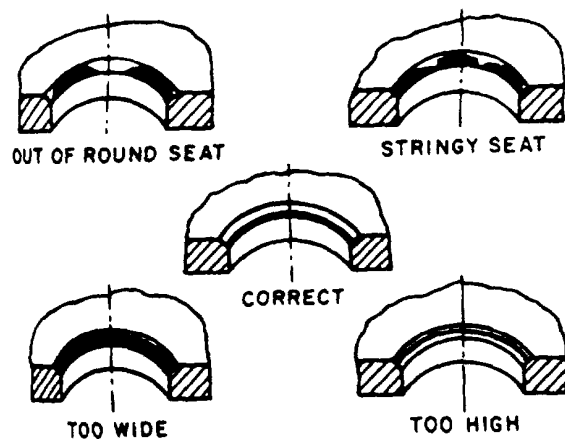

Figure 6-16.—Examples of spotted-in valve seats.

To grind-in a valve, first apply a light coating of grinding compound to the face of the disk. Then insert the disk into the valve and rotate the disk back and forth about one-quarter turn; shift the disk-seat relationship from time to time so the disk will be moved gradually, in increments through several rotations. During the grinding process, the grinding compound will gradually be displaced from between the seat and disk surfaces; therefore, you must stop every minute or so to replenish the compound. When you do this, wipe both the seat and the disk clean before applying the new compound to the disk face.

When you are satisfied that the irregularities have been removed, spot-in the disk to the seat in the manner previously described.

Grinding-in is also used to follow up all machining work on valve seats or disks. When the valve seat and disk are first spotted-in after they have been machined, the seat contact will be very narrow and will be located close to the bore. Grinding-in, using finer and finer compounds as the work progresses, causes the seat contact to become broader. The contact area should be a perfect ring covering about one-third of the seating surface.

Be careful to avoid overgrinding a valve seat or disk. Overgrinding will produce a groove in the seating surface of the disk; it will also round off the straight, angular surface of the disk. Machining is the only process by which overgrinding can be corrected.

## Lapping Valves

When a valve seat contains irregularities that are slightly larger than can be satisfactorily removed by grinding-in, the irregularities can be removed by lapping. A cast-iron tool (lap) of exactly the same size and shape as the valve disk is used to true the valve seat surface. The following are some precautions you should follow when lapping valves:

- Do not bear heavily on the handle of the lap.
- Do not bear sideways on the handle of the lap.
- Change the relationship between the lap and the valve seat occasionally so that the lap will gradually and slowly rotate around the entire seat circle.

- Keep a check on the working surface of the lap. If a groove develops, have the lap refaced.
- Always use clean compound for lapping.
- Replace the compound frequently.
- Spread the compound evenly and lightly.
- Do not lap more than is necessary to produce a smooth even seat.
- Always use a fine grinding compound to finish the lapping job.
- Upon completion of the lapping job, spot-in and grind-in the disk to the seat.

You should use only approved abrasive compounds for reconditioning valve seats and disks. Compounds for lapping valve disks and seats are supplied in various grades. Use a coarse grade compound when you find extensive corrosion or deep cuts and scratches on the disks and seats. Use a medium grade compound as a follow-up to the coarse grade; you may also use it to start the reconditioning process on valves that are not too severely damaged. Use a fine grade compound when the reconditioning process nears completion. Use a microscopic-fine grade for finish lapping and for all grinding-in.

### Refacing Valves

Badly scored valve seats must be refaced in a lathe, with a power grinder, or with a valve reseating machine. However, the lathe, rather than the reseating machine, should be used for refacing all valve disks and all hard-surfaced valve seats. Work that must be done on a lathe or with a power grinder should be turned over to shop personnel.

### Repacking Valves

If the stem and packing of a valve are in good condition, you can normally stop packing gland leaks by tightening up on the packing. You must be careful, however, to avoid excessive thread engagement of the packing gland studs (if used) and to avoid tightening old, hardened packing which will cause the valve to seize. Subsequent operation of such a valve may score or bend the stem.

Coils, rings, and corrugated ribbon are the common forms of packing used in valves. The form of packing to be used in repacking a particular valve will depend on the valve size, application, and type. Packing materials will be discussed in more detail later in this chapter.

## STEAM TRAPS

Steam traps are installed in steam lines to drain condensate from the lines without allowing the escape of steam. There are many different designs of steam traps; some are suitable for high-pressure use and others for low-pressure use.

### TYPES OF STEAM TRAPS

Some types of steam traps that are used in the Navy are the mechanical steam traps, bimetallic steam traps, and orifice-type steam traps.

#### Mechanical Steam Traps

Mechanical steam traps in common use include bucket-type traps and ball-float traps.

The operation of the bucket-type steam trap, shown in figure 6-17, is controlled by the

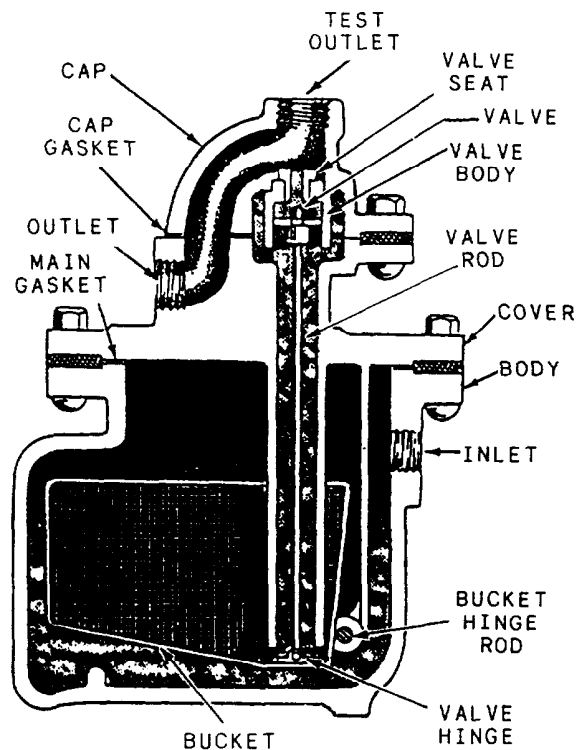

Figure 6-17.—Bucket-type steam trap.

condensate level in the trap body. The bucket valve is connected to the bucket in such a way that the valve closes as the bucket rises. As condensate continues to flow into the trap body, the valve remains closed until the bucket is full. When the bucket is full, it sinks and thus opens the valve. The valve remains open until enough condensate has blown out to allow the bucket to float, thus closing the valve.

Figure 6-18 shows a ball-float steam trap. This trap works much in the same way as the bucket trap. Condensate and steam enter the body of the trap, and the condensate collects at the bottom. As the condensate level rises, the ball float rises until it is raised enough to open the outlet valve of the trap. When the outlet valve opens, the condensate flows out of the trap into the drain system, and the float level drops, shutting off the valve until the condensate level rises again.

### Bimetallic Steam Traps

Bimetallic steam traps of the type shown in figure 6-19 are used in many ships to drain condensate from main steam lines, auxiliary steam lines, and other steam components. The main working parts of this steam trap are a segmented bimetallic element and a ball-type check valve.

The bimetallic element has several bimetallic strips fastened together in a segmented fashion, as shown in figure 6-19. One end of the bimetallic element is fastened rigidly to a part of the valve body; the other end, which is free to move, is

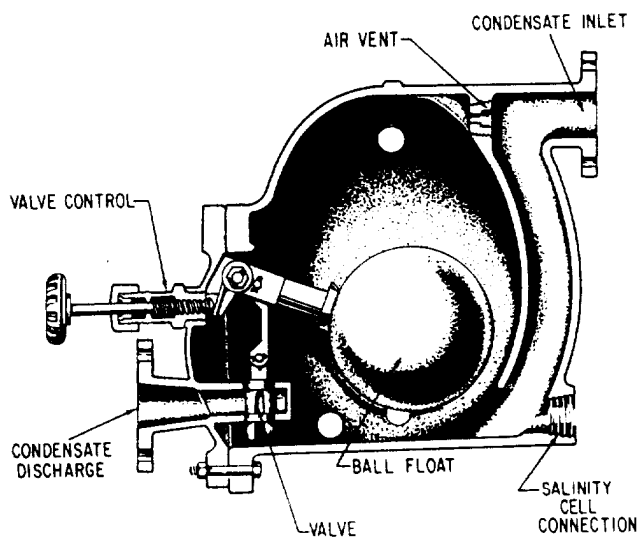

Figure 6-18.—Ball-float steam trap.

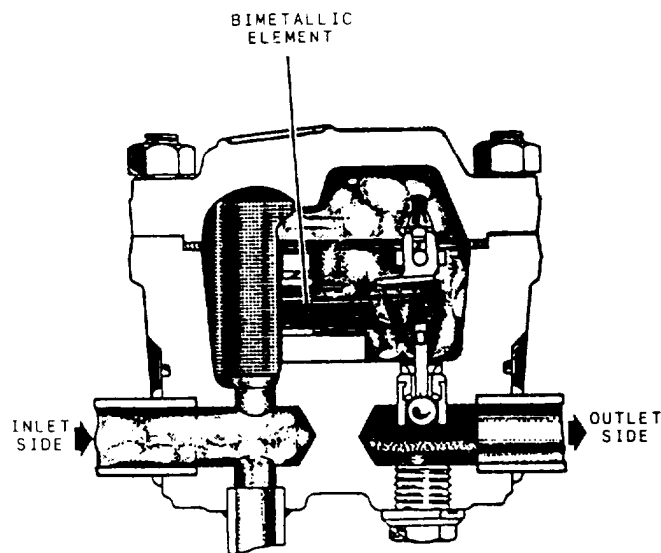

Figure 6-19.—Bimetallic steam trap.

fastened to the top of the stem of the ball-type check valve.

Line pressure acting on the check valve keeps the valve open. When steam enters the trap body, the bimetallic element expands unequally because of the different response to the temperature of the two metals; the bimetallic element deflects upward at its free end, thus moving the valve stem upward and closing the valve. As the steam cools and condenses, the bimetallic element moves downward, toward the horizontal position, thus opening the valve and allowing some condensate to flow out through the valve. As the flow of condensate begins, an unbalance of line pressure across the valve is created; since the line pressure is greater on the upper side of the ball of the check valve, the valve now opens wide and allows a full capacity flow of condensate.

### Orifice Steam Traps

Aboard ship, continuous-flow steam traps of the orifice type are used in systems or services in which condensate forms at a fairly steady rate. Figure 6-20 shows one orifice-type steam trap.

Several variations of the orifice-type steam trap exist, but all have one thing in common—they have no moving parts. One or more restricted passageways or orifices allow condensate to trickle through but do not allow steam to flow through. Besides orifices, some orifice-type steam traps have baffles.

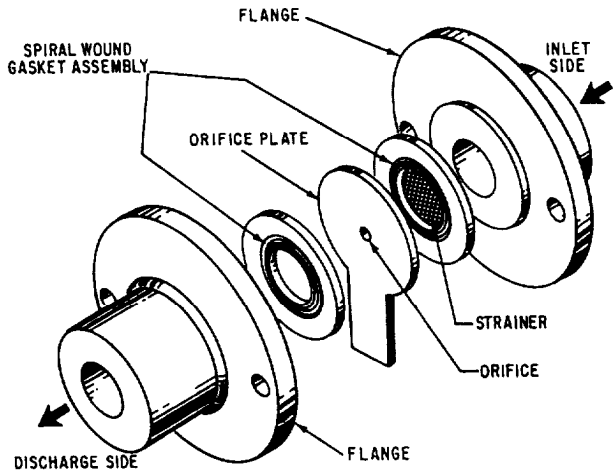

Figure 6-20.—Constant-flow drain orifice.

## MAINTENANCE

A strainer is installed just ahead of each steam trap. The strainer must be kept clean and in good condition to keep scale and other foreign matter from getting into the trap. Scale and sediment can clog the working parts of a steam trap and seriously interfere with the working of the trap.

Steam traps that are not operating properly can cause problems in systems and machinery. One way to check on the operation of a steam trap is to listen to it. If the trap is leaking, you will probably be able to hear it blowing through. Another way to check the operation of steam traps is to check the pressure in the drain system. A leaking steam trap causes an unusual increase in pressure in the drain system. When observing this condition, you can locate the defective trap by cutting out (isolating from the system) traps, one at a time, until the pressure in the drain system returns to normal.

You should disassemble, clean, and inspect defective steam traps. After determining the cause of the trouble, repair or replace parts as required. In some steam traps, you can replace the main working parts as a unit; in others, you may have to grind in a seating surface, replace a disk, or perform other repairs. You should reseal defective trap discharge valves. Always install new gaskets when reassembling steam traps.

## FILTERS AND STRAINERS

Fluids are kept clean in a system principally by devices such as filters and strainers. Magnetic

plugs (fig. 6-21) also are used in some strainers to trap iron and steel particles carried by fluid. Studies have indicated that even particles as small as 1 to 5 microns have a degrading effect, causing failures and hastening deterioration in many cases.

There will always be controversy over the exact definitions of filters and strainers. In the past, many such devices were named filters but technically classed as strainers. To minimize the controversy, the National Fluid Power Association gives us these definitions:

**FILTER**—A device whose primary function is the retention, by some porous medium, of insoluble contaminants from a fluid.

**STRAINER**—A coarse filter.

To put it simply, whether the device is a filter or a strainer, its function is to trap contaminants from fluid flowing through it. “Porous medium” simply refers to a screen or filtering material that allows fluid flow through it but stops various other materials.

## MESH AND MICRON RATINGS

Filters, which may be made of many materials other than wire screen, are rated by MICRON size. A micron is one-millionth of a meter or 39-millionths of an inch. For comparison, a grain of salt is about 70 microns across. The smallest particle visible to the naked eye is about

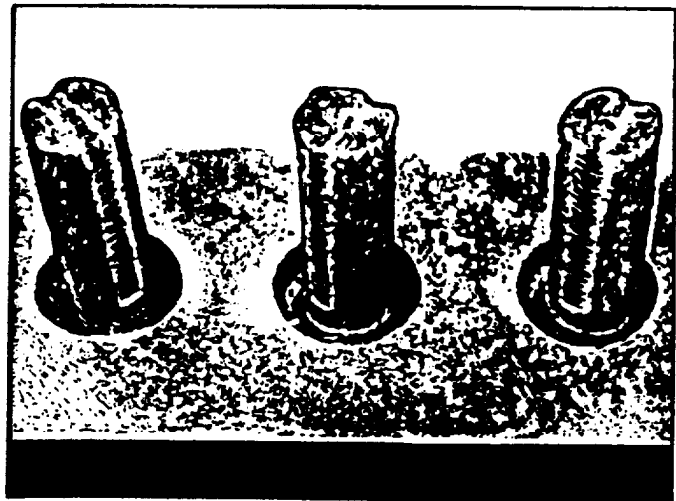
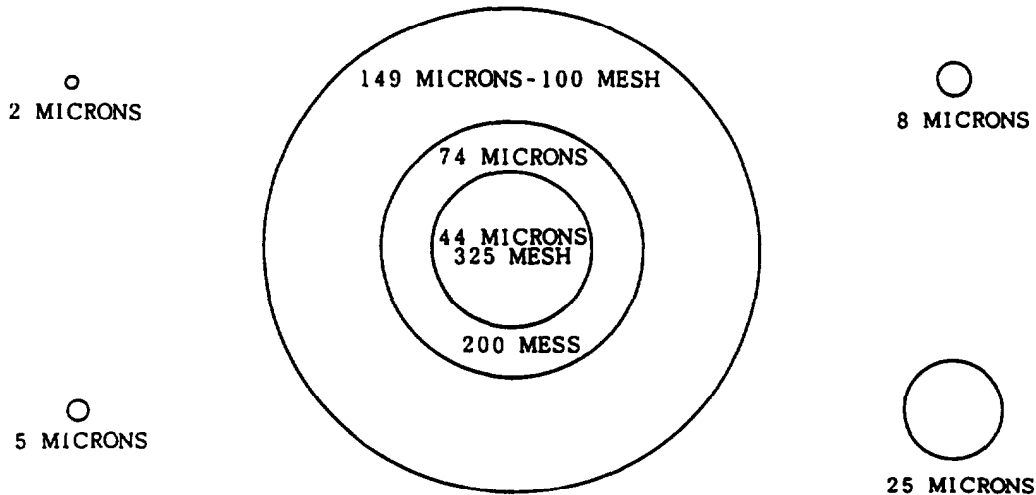

Figure 6-21.—Magnetic plugs.

**RELATIVE SIZE OF MICRONIC PARTICLES**  
MAGNIFICATION 500 TIMES



**RELATIVE SIZES**

|   |            |
|---|------------|
| LOWER LIMIT OF VISIBILITY (NAKED EYE) . . . . . | 40 MICRONS |
| WHITE BLOOD CELLS . . . . .                     | 25 MICRONS |
| RED BLOOD CELLS . . . . .                       | 8 MICRONS  |
| BACTERIA (COCCI) . . . . .                      | 2 MICRONS  |

**LINEAR EQUIVALENTS**

|                    |                             |                   |
|--------------------|-----------------------------|-------------------|
| 1 INCH _____       | 25.4 MILLIMETERS _____      | 25,400 MICRONS    |
| 1 MILLIMETER _____ | 0.0394 INCHES _____         | 1,000 MICRONS     |
| 1 MICRON _____     | 25,400 OF AN INCH _____     | 0.001 MILLIMETERS |
| 1 MICRON _____     | $3.94 \times 10^{-5}$ _____ | 0.000039 INCHES   |

**SCREEN SIZES**

| MESHES PER<br>LINEAR INCH | U.S.<br>SIEVE NO. | OPENING IN<br>INCHES | OPENING IN<br>MICRONS |
|---------------------------|-------------------|----------------------|-----------------------|
| 52.38 _____               | 50 _____          | 0.0117 _____         | 297.0                 |
| 72.45 _____               | 70 _____          | 0.0083 _____         | 210.0                 |
| 101.01 _____              | 100 _____         | 0.0059 _____         | 149.0                 |
| 142.86 _____              | 140 _____         | 0.0041 _____         | 105.0                 |
| 200.00 _____              | 200 _____         | 0.0029 _____         | 74.0                  |
| 270.26 _____              | 270 _____         | 0.0021 _____         | 53.0                  |
| 323.00 _____              | 325 _____         | 0.0017 _____         | 44.0                  |
|                           |                   | 0.00039 _____        | 10.0                  |
|                           |                   | 0.000019 _____       | 0.5                   |

Figure 6-22.—Relationship of micron sizes.

40 microns. Figure 6-22 shows the relationship of the various micron sizes with mesh and standard sieve sizes.

A simple screen or a wire strainer is rated for filtering "fineness" by a MESH number or its near equivalent, STANDARD SIEVE number. The higher the mesh or sieve number, the finer the screen.

When a filter is specified as so many microns, it usually refers to the filter's NOMINAL rating. A filter nominally rated at 10 microns, for example, would trap most particles 10 microns in size or larger. The filter's ABSOLUTE rating, however, would be a somewhat higher size, perhaps 25 microns. The absolute rating is the size of the largest opening or pore in the filter. Absolute rating is an important factor only when it is mandatory that no particles above a given size be allowed to circulate in the system.

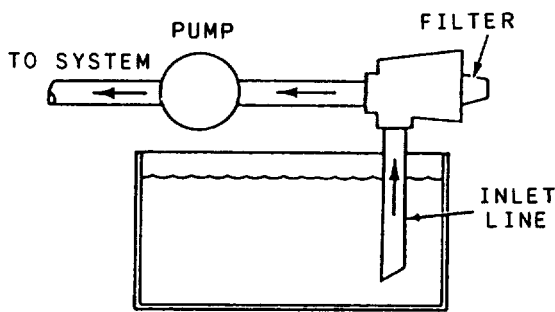

Figure 6-23.—Inlet line filter.

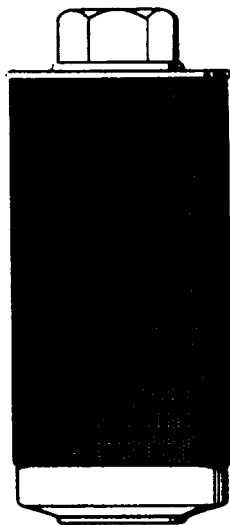

Figure 6-24.—Inlet strainer.

## FILTER/STRAINER LOCATION

There are three general areas in a system for locating a filter; the inlet line, the pressure line, or a return line. Both filters and strainers are available for inlet lines. Filters are normally used in other lines.

### Inlet Filters and Strainers

Figure 6-23 shows the location of an inlet line filter. An inlet line filter is usually a relatively coarse mesh filter. A fine mesh filter (unless it is very large) creates more pressure drop than can be tolerated in an inlet line.

Figure 6-24 shows a typical strainer of the type installed on pump inlet lines inside a reservoir. It is relatively coarse as filters go, being constructed of fine mesh wire. A 100-mesh strainer protects the pump from particles above about 150 microns in size.

### Pressure Line Filters

A number of filters are designed for installation right in the pressure line (fig. 6-25) and can trap much smaller particles than inlet line filters. Such a filter might be used where system components, such as valves, are less dirt-tolerant than the pump. The filter thus would trap this fine contamination from the fluid as it leaves the pump. Pressure line filters must be able to withstand the operating pressure of the system.

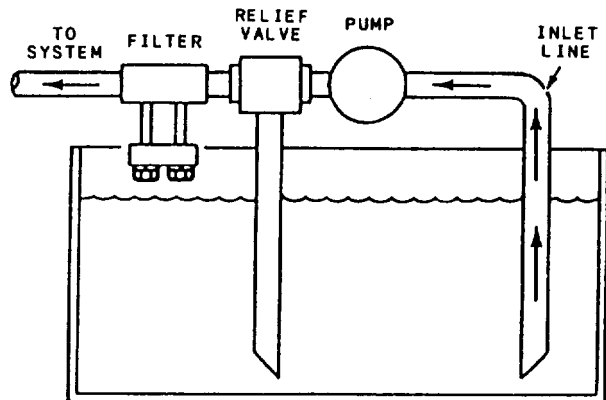

Figure 6-25.—Pressure line filter.

## Return Line Filters

Return line filters (fig. 6-26) also can trap very small particles before the fluid returns to the reservoir/tank. They are particularly useful in systems which do not have large reservoirs/tanks to allow contaminants to settle out of the fluid. A return line filter is nearly a must in a system with a high-performance pump, which has very close clearances and usually cannot be sufficiently protected by an inlet line filter.

## FILTER/STRAINER MATERIALS

The materials used in filters and strainers are classified as mechanical, absorbent, or adsorbent.

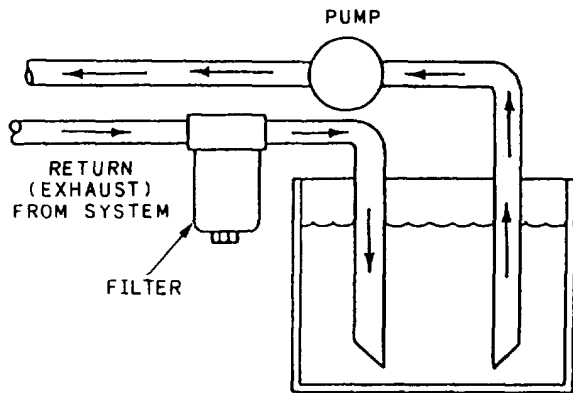

Figure 6-26.—Return line filter.

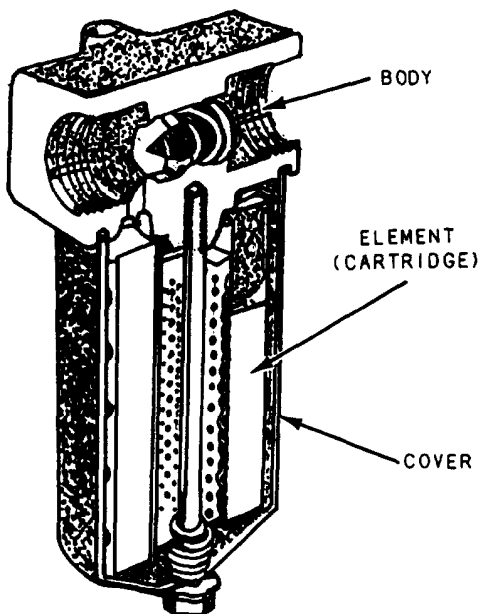

Figure 6-27.—Filter assembly using a surface-type element.

Most strainer material is of the mechanical type which operates by trapping particles between closely woven metal screens and/or disks, and metal baskets. The mechanical type of material is used mostly where the particles removed from the medium are of a relatively coarse nature.

Absorbent filters are used for most minute-particle filtration in fluid systems. They are made of a wide range of porous materials, including paper, wood pulp, cotton, yarn, and cellulose. Paper filters are usually resin-impregnated for strength.

Adsorbent (or active) filters, such as charcoal and Fuller's earth, are used mostly in gaseous or vapor systems. This type of filter material should not be used in hydraulic systems since they remove essential additives from the hydraulic fluid.

## CONSTRUCTION OF FILTER ELEMENTS

Filter elements are constructed in various ways. The three most common filter element construction types are the surface-type (most common), the depth-type, and the edge-type.

Surface-type filter elements (fig. 6-27) are made of closely woven fabric or treated paper with pores to allow fluid to flow through. Very accurate control of the pore size is a feature of the surface-type elements.

A depth-type filter element (fig. 6-28) is composed of layers of a fabric or fibers which provide many tortuous paths for the fluid to flow

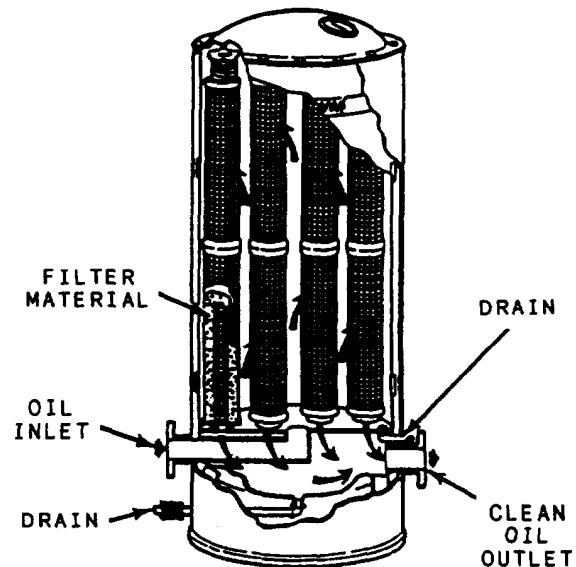

Figure 6-28.—Depth-type filter element.

through. The pores or passages vary in size, and the degree of filtration depends on the flow rate. Increases in flow rate tend to dislodge trapped particles. This filter is limited to low-flow, low pressure-drop conditions.

An edge-type filter element (fig. 6-29) separates particles from fluids passing between finely spaced plates. The filter shown features stationary cleaner blades that scrape out the collected contaminants when the handle is twisted to turn the element.

## TYPES OF FILTERS

In this section we will discuss the various filters (simplex, duplex, full flow, proportional flow, and indicator) that you will most frequently find installed in equipment.

### Simplex Filter

The simplex filter has one or more cylindrically shaped fine mesh screens or perforated metal sheets. The size of the opening in the screens or the perforated metal sheets determines the size of particles filtered out of the fluid. The design of this type of filter is such that total flow must pass through a simplex filter.

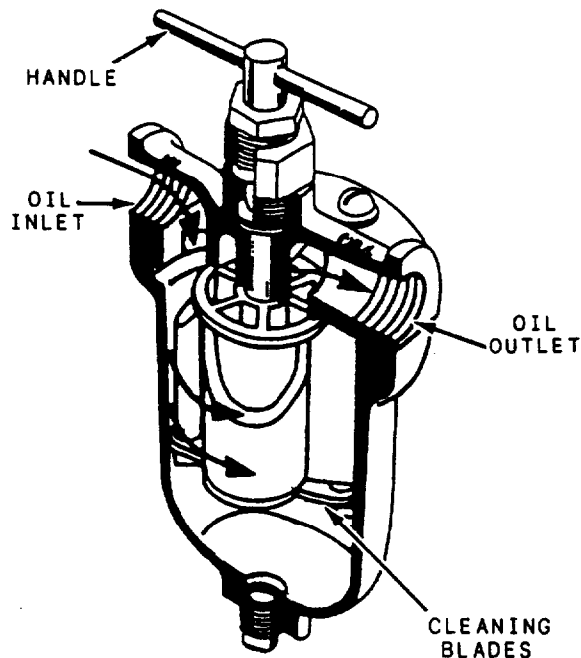

Figure 6-29.—Edge-type filter element.

## Duplex Filters

Duplex filters are similar to simplex filters except in the number of elements and in provision for switching the flow through either element. A duplex filter may consist of a number of single element filters arranged in parallel operation, or it may consist of two or more filters arranged within a single housing. The full flow can be diverted, by operation of valves, through any single element. The duplex design is most commonly used in fuel or hydraulic systems because the ability to shift to an offline filter when the elements are cleaned or changed is desirable without the system being secured.

### Full-Flow Filters

The term full-flow applied to a filter means that all the flow into the filter inlet port passes through the filtering element. In most full-flow filters, however, there is a bypass valve preset to open at a given pressure drop and divert flow past the filter element. This prevents a dirty element from restricting flow excessively. Figure 6-30 shows a full-flow filter. Flow, as shown, is out-to-in; that is, from around the element through it to its center. The bypass opens when total flow can no longer pass through the contaminated element without raising the system pressure. The element is replaceable after removing a single bolt.

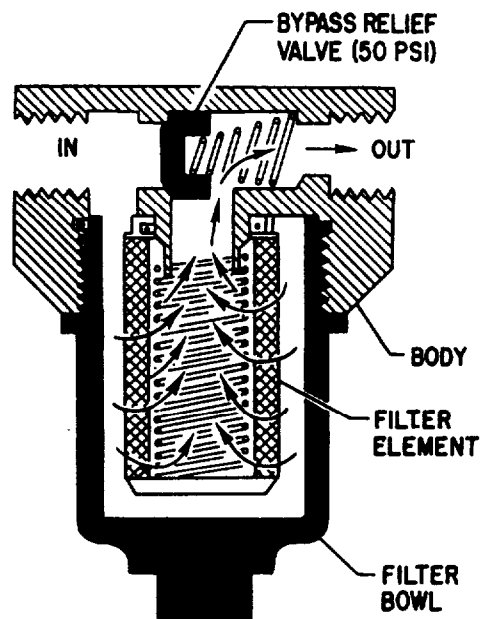

Figure 6-30.—Full-flow filter.



## Proportional-Flow Filters

A proportional-flow filter (fig. 6-31) may use the Venturi effect to filter a portion of the fluid flow. The fluid can flow in either direction. As it passes through the filter body, a venturi throat causes an increase in velocity and a decrease in pressure. The pressure difference forces some of the fluid through the element to rejoin the main stream at the venturi. The amount of fluid filtered is proportional to the flow velocity. Hence the name proportional-flow filter.

## Indicating Filters

Indicating filters are designed to signal the operator when the element needs cleaning. There are various types of indicators, such as color-coded, flag, pop-up, and swing arm. Figure 6-32 shows a color-coded indicating filter. The element is designed so it begins to move as the pressure increases due to dirt accumulation. One end is linked to an indicator that shows the operator just

how clean or dirty the element is. Another feature of this type of filter is the ease and speed with which the element can be removed and replaced. Most filters of this kind are designed for inlet line installation.

## Filter/Separator

The filter/separator is a two-stage unit consisting of a coalescer stage and a separator stage within a single housing. Each stage is made up of replaceable elements, the number of which is determined by such considerations as the capacity of the elements in gallons per minute (gpm) and the elements dirt retaining properties. Coalescer elements filter solids from the fluid and cause small particles of undissolved water to combine (coalesce) into larger drops of water that, because of their weight, will settle in the filter/separator sump. Separator elements are provided to remove any remaining free water that has not coalesced. Water that accumulates in the

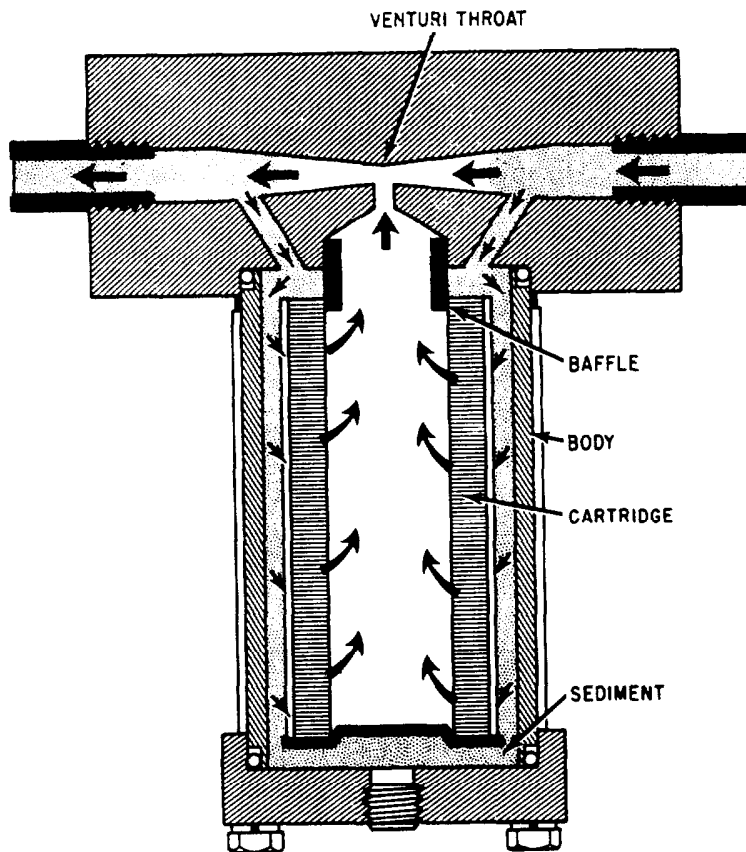

Figure 6-31.—Proportional-flow filter.

any substantial increase in the overall size and weight of the unit.

### Type of Construction

Surface heat exchangers are often given names that indicate general features of design and construction. Basically, all surface heat exchangers are of SHELL-AND-TUBE construction. However, the shell-and-tube arrangement is modified in various ways and in some cases it is not easy to recognize the basic design. Shell-and-tube heat exchangers include such types as (1) straight tube, (2) U-bend tube, (3) helical or spiral tube, (4) double tube, (5) strut tube, and (6) plate tube heat exchangers.

**STRAIGHT TUBE.**—In straight tube heat exchangers, the tubes are usually arranged in a bundle and enclosed in a cylindrical shell. The ends of the tubes may be expanded into a tube sheet at each end of the bundle, or they may be expanded into one tube sheet and packed and ferruled into the other. The ferrules allow the tube to expand and contract slightly with temperature changes.

**U-BEND TUBE.**—U-bend tube heat exchangers, sometimes called RETURN BEND heat exchangers, have a bundle of U-shaped tubes inside a shell. Since the tubes are U-shaped, there is only one tube sheet. The shape of the tubes provides enough allowance for expansion and contraction.

**HELICAL OR SPIRAL TUBE.**—Helical or spiral tube heat exchangers have one or more coils of tubing installed inside a shell. The tubes may communicate with headers at each end of the shell or, if a relatively simple unit, the ends of the tubing may pass through the shell and serve as the inlet and the outlet for the fluid that flows through the coil of tubing.

**DOUBLE TUBE.**—Double tube heat exchangers have one tube inside another. One fluid flows through the inner tube and the other fluid flows between the outer and inner tubes. The outer tube may thus be regarded as the shell for each inner tube. The shells, or outer tubes, are usually arranged in banks and are connected at one end by a common tube sheet with a partitioned cover that serves to direct the flow. Many double tube heat exchangers are of U-bend construction to allow for expansion and

contraction. The fuel oil service/transfer heaters, commonly used by the Navy, are examples of a double tube heat exchanger.

**STRUT TUBE AND PLATE TUBE.**—Strut tube and plate tube heat exchangers are noticeably different in design from the other shell-and-tube heat exchangers. The tubes in both strut tube and plate tube heat exchangers consist of pairs of flat, oblong strips; one fluid flows inside the tubes and the other flows around the outside. Strut tube and plate tube heat exchangers are used primarily as water coolers and lubricating oil coolers in internal-combustion engines; they are also used as lube oil coolers for start air compressors.

### Direction of Flow

In surface heat exchangers the fluids may flow parallel to each other, counter to each other, or at right angles to each other.

**PARALLEL FLOW.**—In parallel flow (fig. 6-33), both fluids flow in the same direction. If a parallel flow heat exchanger has a lengthy heat transfer surface, the temperatures of the two fluids will be practically equal as the fluids leave the heat exchanger.

**COUNTERFLOW.**—In counterflow (fig. 6-34), the two fluids flow in opposite directions. Counterflow heat exchangers are used in many applications that require large temperature changes in the cooled or heated fluids. Fuel oil heaters, lube oil coolers, and many internal-combustion engine coolers are examples of this type.

**CROSSFLOW.**—In crossflow (fig. 6-35), one fluid flows at right angles to the other. Crossflow is particularly useful for removing latent heat, thus condensing a vapor to a liquid. Counterflow

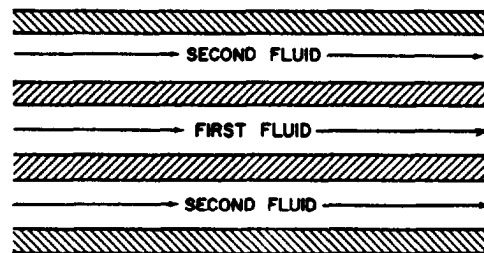

Figure 6-33.—Parallel flow in heat exchanger.

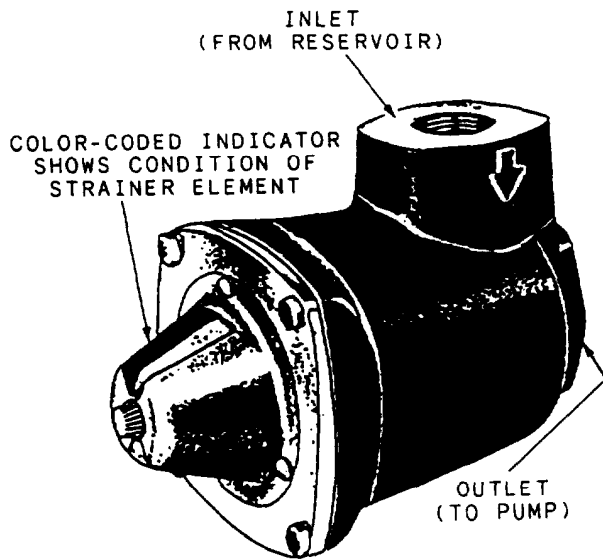

Figure 6-32.—Color-coded indicating filter.

filter/separator sump is removed through a drain line, either automatically or manually.

### In-Line or Cone Filter

In-line or cone filters have conical-shaped fine mesh screen or perforated metal sheet that is inserted into the system pipe and secured by a set of flanges. Its system application determines whether it is considered a filter or strainer. It is most commonly used in seawater systems, where it is considered a strainer. This type of filter is prohibited in fuel systems.

### MAINTENANCE

Proper operation of filters, strainers, and filter separators is essential for satisfactory gas turbine and diesel engine performance. Besides clogging the systems with foreign matter, continued operation with unfiltered fluids results in accelerated pump wear and system degradation. Routine maintenance of filters, strainers, and filter/separators is adequately covered in *Naval Ships' Technical Manual*, Chapter 541, "Petroleum Fuel Stowage, Use, and Testing," paragraphs 541-8.51 through 541-8.59.

## HEAT EXCHANGERS

Any device or apparatus designed to allow the transfer of heat from one fluid (liquid or gas) to

another fluid is a heat exchanger. Distilling plants, MRG lube oil coolers, fuel oil transfer heaters, and fuel oil service heaters are primary examples of heat exchangers; in common usage, however, they are not referred to as heat exchangers.

For heat to transfer from one substance to another, a difference in the temperature of the two substances must exist. Heat flow or heat transfer can occur only from a substance that is at a higher temperature to a substance that is at a lower temperature. When two objects that are at different temperatures are placed in contact with one another, or near each other, heat will flow from the warmer object to the cooler one until both objects are at the same temperature. Heat transfer occurs at a faster rate when there is a large temperature difference than when there is only a slight temperature difference. As the temperature difference approaches zero, the rate of heat flow also approaches zero.

In some heat exchangers we want to RAISE THE TEMPERATURE of one fluid. Fuel oil heaters, combustion air preheaters, lube oil heaters, and many other heat exchangers used aboard ship serve this function.

In other heat exchangers, we want to LOWER THE TEMPERATURE of one fluid. Lube oil coolers, start air coolers, and bleed air coolers are examples of this type of heat exchanger.

In this section we describe some of the heat exchangers that you will find in the engineering spaces.

## CLASSIFICATION OF HEAT EXCHANGERS

Heat exchangers may be classified according to the path of heat flow, the relative direction of the flow of the fluids, the number of times either fluid passes the other fluid, and the general construction features, such as the type of surface and the arrangement of component parts. The types of heat exchangers in common use in naval ships are described in the following sections by these basic methods of classification.

### Type of Surface

Surface heat exchangers are known as PLAIN SURFACE units if the surface is relatively smooth, or as EXTENDED SURFACE units if the surface is fitted with rings, fins, studs, or some other kind of extension. The main advantage of the extended surface unit is that the extensions increase the heat transfer area without requiring

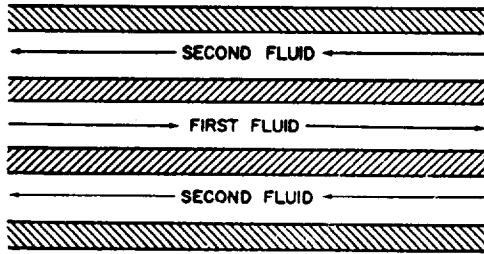

Figure 6-34.—Counterflow in heat exchanger.

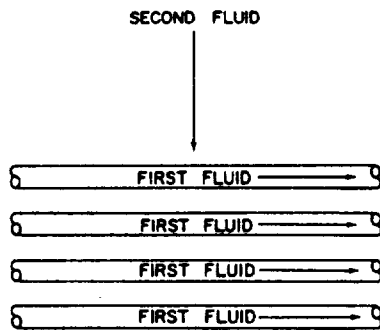

Figure 6-35.—Crossflow in heat exchanger.

and crossflow heat exchangers are more commonly used than the parallel flow aboard ship. In many heat exchangers, the types of flow are combined in various ways so it is not always easy to determine whether the flow is basically parallel, counter, or cross.

### Number of Passes

Surface heat exchangers may be classified as SINGLE-PASS units if one fluid passes another only once, or as MULTIPASS units if one fluid passes another more than once. Multipass flow is obtained by the arrangement of the tubes and the fluid inlets and outlets or by the use of baffles to guide a fluid so it passes the other fluid more than once before it leaves the heat exchanger.

### Path of Heat Flow

When classified according to the path of heat flow, heat exchangers are of two basic types. In the INDIRECT or SURFACE heat exchanger, the heat flows from one fluid to the other through a tube, plate, or other surface that separates the two fluids; in the DIRECT-CONTACT heat

exchanger, the heat is transferred directly from one fluid to another as the two fluids mix. Practically all heat exchangers used aboard Navy ships are of the indirect or surface type.

## MAINTENANCE OF HEAT EXCHANGERS

Foreign matter lodged on or in the tubes of a heat exchanger interferes with and reduces the rate of heat transfer from one fluid to the other. Heat exchangers requiring the most attention are those where the cooling medium is seawater. Marine growth can form on the tube surfaces and, in extreme cases, completely block the flow.

The seawater side of the tubes should be cleaned as often as necessary. The intervals will depend on the rate that slime, marine growth, scale, mud, oil, grease, and so forth, are deposited on the tube walls. The amount of such deposits depends on the operating environment and existing conditions. Operation in shallow water, for example, may cause rapid fouling of the tubes.

The resistance of heat exchanger tubes to corrosion depends on a thin, adherent, continuous film of corrosion products on the surface exposed to seawater; therefore, you must be extremely careful when cleaning the tubes not to use abrasive tools capable of marring or scratching the surface of the tubes. You should never use wire brushes or rubber plugs having metal parts inside condenser tubes. Any scratch or perforation of the corrosion-resistant film will form a pit that will widen and deepen. Eventually this can result in tube failure (through corrosion pitting), in the same manner as occurs when foreign matter lodges on the tube surface.

For ordinary cleaning, push an air lance through each tube, wash the tube sheets clean, and remove all foreign matter from the water chests. In installations with severe fouling, push a water lance through each tube to remove foreign matter. For extreme fouling, you should run a rotating bristle brush through each tube—or drive soft rubber plugs, available at shipyards, through the tubes by using air or water pressure. Afterwards, ensure this procedure is followed by water-lancing.

## ZINCS

Where zinc anodes are required to protect the heat exchanger materials from electrolysis, good metallic contact must exist between the anodes and the metal of the condenser.

A casual inspection of a badly scaled zinc anode, especially while it is still wet, may lead personnel to believe that the metal is exposed instead of the scale. The anode, even though it appears to be in good condition, should be cleaned with a chipping hammer to learn the true condition of the metal. Whenever zincs are inspected or cleaned, check the condition of the metallic contact between the anode and its support.

## PIPING

The control and application of fluid power would be impossible without a suitable means of conveying the fluid from the power source to the point of application. Fluid lines used for this purpose are called piping. They must be designed and installed with the same care applicable to other components of the system. To obtain this desired result, attention must be given to the various types, materials, and sizes of lines available for the fluid power system. The different types of lines and their application to fluid power systems are described in the first part of this section. The last part of this section is devoted to the various connectors applicable to the different types of fluid lines.

### IDENTIFICATION OF PIPING

The three most common lines used in fluid power systems are pipe, tubing, and flexible hose. They are sometimes referred to as rigid (pipe), semirigid (tubing), and flexible piping. In commercial usage, there is no clear distinction between piping and tubing, since the correct designation for each product is established by the manufacturer. If the manufacturer calls its product pipe, it is pipe; if the manufacturer calls it tubing, it is tubing.

In the Navy, however, a distinction is made between pipe and tubing. The distinction is based on the method used to determine the size of the product. There are three important dimensions of any tubular product—outside diameter (OD), inside diameter (ID), and wall thickness. The product is called tubing if its size is identified by actual measured outside diameter and by actual wall thickness. The product is called pipe if its size is identified by a nominal dimension and wall thickness.

### PIPING MATERIALS

The pipe and tubing used in fluid systems today are commonly made from steel, copper, brass, aluminum, and stainless steel. The hose

assemblies are constructed of rubber or Teflon<sup>®</sup>. Each of these materials has its own distinct advantages or disadvantages, depending upon its application.

Steel piping and tubing are relatively inexpensive, have a high tensile strength, are suitable for bending and flanging, and are very adaptable to high pressures and temperatures. Its chief disadvantage is a comparatively low resistance to corrosion.

Copper and brass piping and tubing have a high resistance to corrosion and are easily drawn or bent. Pipe or tubing made from these materials is unsuitable for systems with high temperatures, stress, or vibration because they have a tendency to harden and break.

Aluminum has many characteristics and qualities required for fluid systems. It has a high resistance to corrosion, is lightweight, is easily drawn or bent, and (when combined with certain alloys) will withstand high pressures and temperatures.

Stainless steel piping or tubing is relatively lightweight and is used in a system that will be exposed to abrasion, high pressure, and intense heat. Its main disadvantage is high cost.

### FLEXIBLE HOSE ASSEMBLIES

The flexible hose assembly is a specific type of flexible device that uses reinforced rubber hose

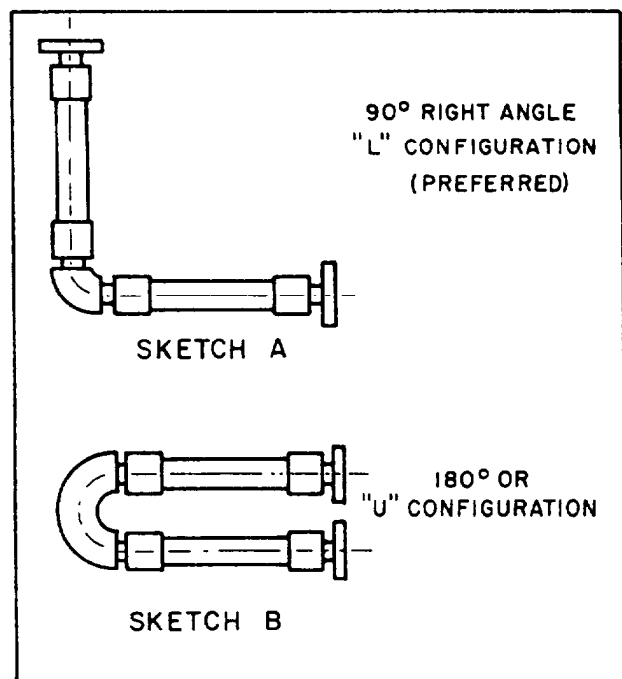

Figure 6-36.—90° and 180° flexible hose configurations.

and metal end fittings. It is used to absorb motions between resiliently mounted machinery and fixed or resiliently mounted piping systems. The motions to be considered may be of either relatively large size due to high-impact shock or of smaller size due to the vibratory forces of rotating machinery. The configuration selected must contain enough hose to accommodate shock and vibratory motions without stressing the hose assembly or machinery to an unacceptable degree.

**Approved Flexible Hose Configurations**

The arrangements (or configurations) determined to give the best noise attenuation characteristics and to accommodate the motions of resiliently mounted equipment are shown in figures 6-36 and 6-37. The 90° “L” configuration (dogleg) is the preferred configuration; however, where space and piping arrangement

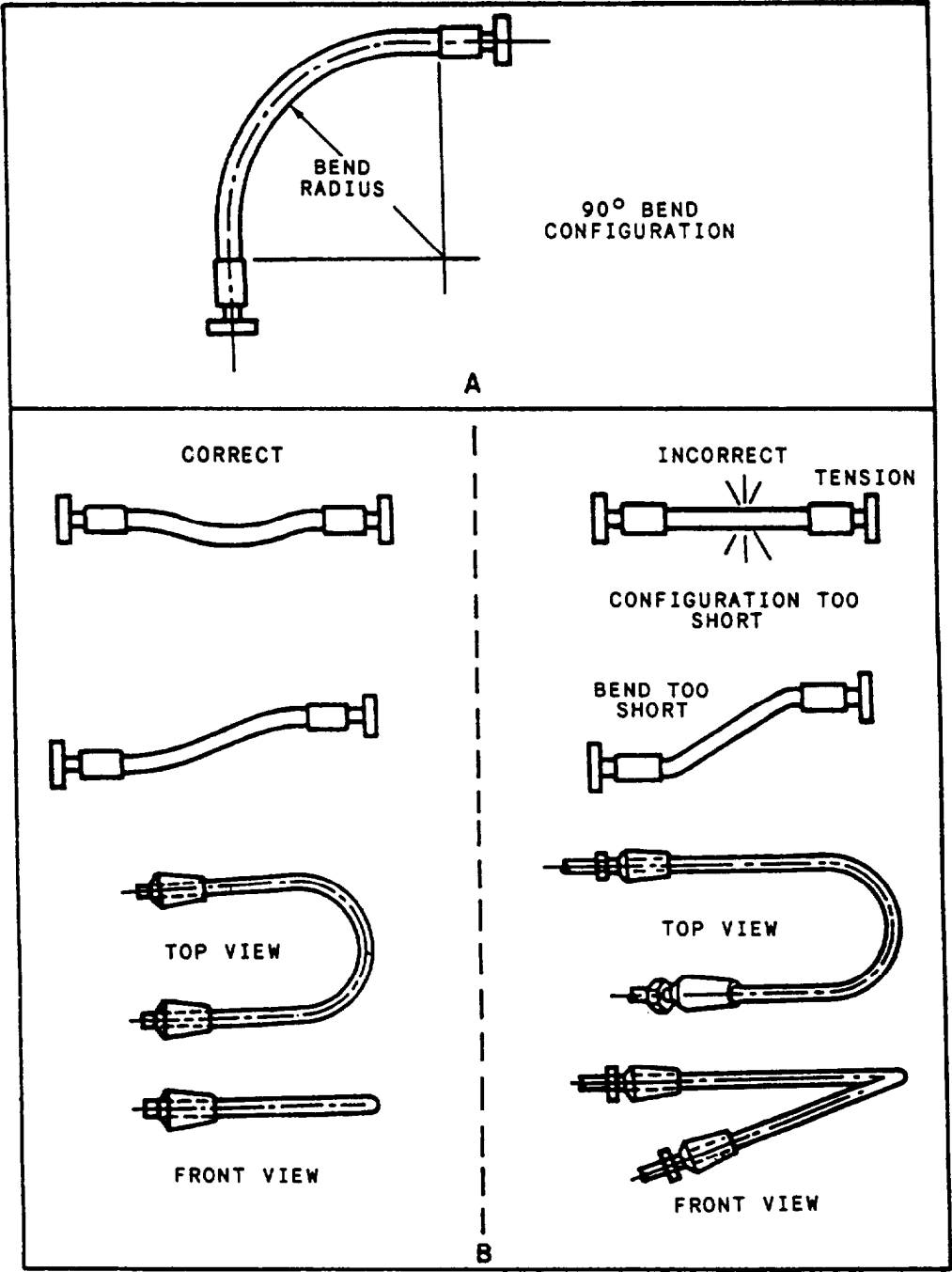

Figure 6-37.—Other approved single hose length configurations.

prohibit the use of the “L” configuration, a 180° or “U” configuration may be used. The 90° “L” and 180° “U” configurations are shown as sketches A and B of figure 6-36.

A configuration that uses a single length of hose bent to about 90° is approved where the hose does not bend below its specified minimum bending radius when the equipment moves to the maximum limits allowed by its mounts (view A of fig. 6-37). The straight single hose configuration and the 180° single hose bend (view B of fig. 6-37) are also approved for use where the hose size is less than 1 inch ID.

Flexible connections that use rubber hose are not used in systems where the maximum continuous operating temperature is in excess of 200°F.

### Hose Identification

Hose is identified by the manufacturer’s part number and the size or dash number. The dash number is the nominal hose inside diameter in sixteenths of an inch. Hose built to military specification (MILSPEC) requirements have the number of the specification and, where applicable, the class of hose, the quarter and year of manufacture, and the manufacturer’s trademark. This information is molded or otherwise permanently repeated periodically on the hose cover (sometimes referred to as the “lay line marking”). Other information permanently marked on the hose cover is the manufacturer’s code and the date of manufacture. For interpretations of commercial lay line markings, refer to the appropriate manufacturer’s catalog or manual.

### Fitting Identification

Use special care in identifying hose fittings because their designation is more complex than hose. A fitting suitable for connecting to a given hose size can end in more than one size and type of connection to the piping. A fitting, therefore, must be identified by the manufacturer’s part number, the size of the end connection that joins the piping system, and the dash size to show the size hose to which it makes up. For interpretation of manufacturer markings, consult the appropriate manufacturer’s manual. Fittings

meeting military specification requirements have the specification number, class of fitting (where applicable), type, size, and manufacturer’s trademark.

A cross index between the manufacturers’ designations and military specifications and information to correctly identify approved hoses and fittings can be found in *Piping Devices, Flexible Hose Assemblies*, volume 1, NAVSEA S6430-AE-TED-010.

### Inspection of Hose and Fittings Prior To Make-Up

The basic inspection methods for hose and fittings are listed as follows:

1. Ensure that the hose and couplings are the correct ones for the intended use and that the age of the rubber hose does not exceed a shelf life of 4 years. Teflon<sup>®</sup> and metal hose have no limiting shelf life.
2. Inspect for signs that the hose has been twisted. Use the hose lay line for a guide to determine whether or not any twist is present. If twisted, reject.
3. Inspect for signs that the hose has been kinked or bent beyond its minimum bend radius. If suspect, reject.
4. Inspect for signs of loose inner liner. If found, cut the hose to see if this condition exists throughout the entire length. If suspect, reject.
5. Visually check the inner liner and outer rubber cover of the hose for breaks, hairline cuts, or severe abrasions. If any suspect areas are found, reject.
6. Inspect the fittings for defects, such as cracked nipples and damaged threads. If suspect, or if defects are found, reject.

Procedures for making up hoses and fittings can also be found in the *Naval Ships’ Technical Manual*, chapter 505, or the appropriate manufacturer’s catalog or manual, and are not covered here due to the many types available.

### Visual Inspection

After assembling the hose and fittings, visually inspect the entire configuration to ensure the following:

1. The hose inner liner and outer cover is intact and contains no cuts or harmful abrasions.

2. The hose has not been twisted (check the lay line).
3. The circumferential chalk line on the hose next to the coupling has been drawn before the hydrostatic test.
4. The internal spring (if installed) is evenly spaced and flat against the inner liner. Ensure a gap exists between one of the end fittings and the end of the spring.

### Hydrostatic Test

Upon completion of visual inspection, hydrostatically shop test the hose assembly with fresh water. For each style and size hose, test the pressure to ensure that it is twice the maximum allowable pressure shown in chapter 505 of *Naval Ships' Technical Manual*. When you test pressure, hold for not more than 5 minutes nor less than 60 seconds. When test pressure is reached, visually inspect the hose assembly for the following defects:

1. Leaks or signs of weakness
2. Twisting of the hose (this indicates that some twist existed before pressure was applied)
3. Slippage of the hose out of the coupling (a circumferential chalk line can help determine this)

If any of the above occurs, reject the assembly.

### CAUTION

**Do not confuse hose elongation under pressure with coupling slippage. If the chalk line returns to near its original position, no slippage has occurred and the assembly is satisfactory. If there is any doubt, perform a second test. If doubt persists after the second test, reject the assembly.**

### Air Test

Hose assemblies intended for gas or air service must also be tested with air or nitrogen at 100 psi and the assembly immersed in water. Random bubbles may appear over the hose and in the fitting area when the assembly is first

pressurized. Do not construe this as a defect. However, if the bubbles persist in forming at a steady rate at any particular point on the hose, reject the assembly.

### Installation of Flexible Hose Assemblies

After completion of tests, proceed as follows:

1. Install as soon as possible.
2. Do not leave the hose assembly around on decks or on docks where they can be subjected to any form of abuse.
3. Make up hose assemblies as late as possible during the availability schedule to minimize the chances of damage while the ship is being overhauled.
4. Install plastic dust caps, plugs, or tape ends to protect threaded areas until the hose assembly is installed.

When installing flexible base connections, observe the following requirements:

1. Ensure each leg of hose is free of twist between end fittings.
2. Ensure the fixed piping near the flexible configuration is properly supported so that it does not vibrate from the resiliently mounted equipment.
3. Ensure the configurations are clear of all surrounding structures and remain so when resiliently mounted equipment moves through its maximum excursion under shock.
4. Locate flexible connection as close as possible to the sound-mounted unit.
5. Support the free elbow of the configuration with an approved pipe hanger so as not to sag or otherwise unduly stress or distort the configuration.
6. Do not appreciably change the alignment of the hose configuration between the unpressurized and pressurized conditions. If you do, you could cause misalignment or improper support at the fixed end.



7. Obtain metal hose assembly identification tags (fig. 6-38) from your local SIMA and secure them onto one of the legs of the hose configuration. The tag is made of a non-corroding material. Do not remove or alter the tag once it is attached.
8. Leave the configuration in a condition where one end can hang down unsupported during installation or dismantling of piping. Otherwise, you can damage the hose wire reinforcement.

### **Periodic Inspection By Ship's Force**

No less than once a quarter, preferably about once a month, visually inspect all flexible piping connections to determine whether any signs of weakness or unusual conditions exist. Inspect the hose in other systems semiannually. To assist you when performing this inspection, you should compile a checkoff list of hose assemblies and locations for your assigned spaces or equipment. This list will consist of all flexible devices installed (and their locations) together with a list of inspections to be performed on each flexible device. When you perform the listed inspections, note the following:

1. Evidence of leakage at fitting ends.
2. Discoloration of fittings (possible indication wire reinforcement is rusting).
3. Slippage of hose out of fitting.
4. Twisting of hose or other distortion or unusual appearance.
5. Cracking of outer rubber cover.
6. Rubber cover rubbed thin by abrasion or chafing.
7. High pulsations, fluid hammer, or whipping caused by pressure pulsations.
8. Large vibrations due to improper supports at the fixed end.
9. Large area of hose covered with paint. (The intent of this requirement is to eliminate having the flexible hose connections deliberately painted. The hose does not have to be replaced if a few paint drops inadvertently fall onto it. Do not attempt to clean off dried paint from the hose.)
10. Check hangers to ensure they have not broken off, distorted, or otherwise damaged.
11. Soft spots or bulges on hose body (indicates weakening of bond between

outer rubber cover and wire braid or deterioration of the reinforcing wire).

12. If results of visual inspection indicates weakening of hose or fittings, or makes hose configuration suspect, replace the hose immediately, if at all possible. Keep under surveillance while under pressure until it is replaced.
13. If necessary to remove a flexible hose configuration from the system, examine the interior of the hose for cracks or other signs of deterioration of the inner liner. Do not damage the liner by trying to dislodge sea growth. Do not remove the end fittings from any section of hose which is to be installed.
14. Presence of identification tag.

### **Storage**

The following guidelines are recommended for proper storage of hose and fittings:

- Hose-Hose should be stored in a dark, dry atmosphere away from electrical equipment; temperature should not exceed 125°F. Storage in straight lengths is preferred, but if hose is to be coiled, take care to ensure the diameter of the bend is not less than 3 feet. To prevent damage during storage, wrap the hose with burlap or other suitable material.
- Reusable End Fittings-Protect all threads with tape or other suitable material, and wrap the entire fitting in a protective covering to prevent nicking or other damage.

### **Shelf Life**

The following are shelf life requirements for hose and reusable end fittings:

- Hose-Do not install reinforced rubber hose that is over 4 years old from the date of manufacture. This time is measured from the quarter and year of manufacture but does not include the quarter year of manufacture. Consider the shelf life of hose ended upon installation aboard ship. To ensure against its accidental use, dispose of any hose not installed that has exceeded the above shelf life.

- Reusable End Fittings-There is no shelf life for end fittings. They should be replaced on an individual basis when examination makes them suspect.

### Servicing

No servicing or maintenance is required since hose or fittings must be replaced at the slightest suspicion of potential failure. If a fitting is removed from a section of hose, that hose section must not be reused, regardless of its service life.

### Service Life of Rubber Hose

All rubber hose has a periodic replacement time. All flexible rubber hose connections will be replaced every 5 years ( $\pm$  6 months) in critical systems and every 12 years in noncritical systems. Wire braided Teflon® hose has no specified shelf or service life. Its replacement is based on inspection of the hose for excessive wear or damage.

### FITTINGS

Some type of connector must be provided to attach the pipe, tube, or hose to the other components of the system and to connect sections of the line to each other. There are many different types of connectors (commonly called fittings) provided for this purpose. Some of the most common types of fittings are covered in the following paragraphs.

### Threaded Joints

The threaded joints are the simplest type of pipe fittings. Threaded fittings are not widely used aboard modern ships except in low-pressure water piping systems. The pipe ends connected to the union are threaded, silver-brazed, or welded into the tail pieces (union halves); then the two ends are joined by setting up (engaging and tightening up on) the union ring. The male and female connecting ends of the tail pieces are carefully ground to make a tight metal-to-metal fit with each other. Welding or silver-brazing the ends to the tail pieces prevents contact of the carried fluid or gas with the union threading.

|  |                          |
|--|--------------------------|
| HOSE ASSEMBLY IDENTIFICATION TAG (SHIP _____ ) |                          |
| SRD DWG NO _____                               | SYST. PRESSURE _____ PSI |
| SRP ITEM NO _____                              | START SERVICE            |
| HOSE TYPE/SIZE _____                           | DATE _____               |
| SERVICE _____                                  |                          |

A

ID TAG WHEN SELECTED RECORD DRAWING IS AVAILABLE

|  |                          |
|--|--------------------------|
| HOSE ASSEMBLY IDENTIFICATION TAG (SHIP _____ ) |                          |
| PIPING ARR. DWG. NO. _____                     | SYST. PRESSURE _____ PSI |
| ASSY. PC. NO. _____                            | START SERVICE            |
| HOSE TYPE/SIZE _____                           | DATE _____               |
| SERVICE _____                                  |                          |

B

ID TAG WHEN SELECTED RECORD DRAWING DOES NOT EXIST

Figure 6-38.—Hose assembly identification tags.

## Bolted Flange Joints

Bolted flange joints (fig. 6-39) are suitable for all pressures now in use. The flanges are attached to the piping by welding, brazing, screw threads (for some low-pressure piping), or rolling and bending into recesses. Those shown in figure 6-39 are the most common types of flange joints used. Flange joints are manufactured for all standard fitting shapes, such as the tee, cross, elbow, and return bend. The Van Stone and the welded-neck flange joints are used extensively where piping is subjected to high pressures and heavy expansion strains. The design of the Van Stone flange makes it easier to line up the fastening holes in the two parts of the flange.

## Welded Joints

The majority of joints found in subassemblies of piping systems are welded joints, especially in high-pressure piping. The welding is done according to standard specifications which define the material and techniques. Three general classes of welded joints are fillet-weld, butt-weld, and socket-weld (fig. 6-40).

## Silver-Brazed Joints

Silver-brazed joints (fig. 6-41) are commonly used for joining nonferrous piping when the pressure and temperature in the lines make their use practicable—temperatures must not exceed 425 °F; for cold lines, pressure must not exceed 3000 psi. The alloy is melted by heating the joint

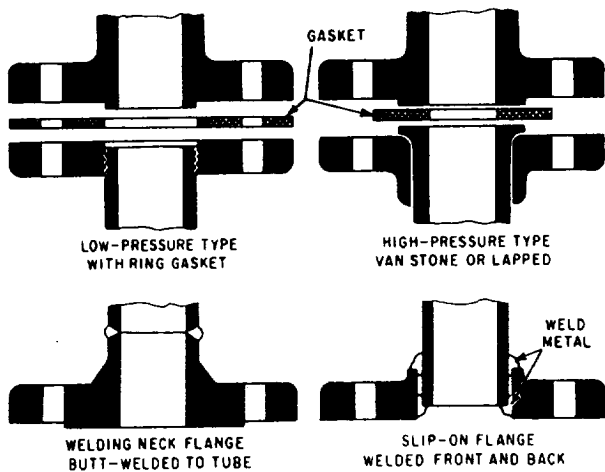

Figure 6-39.—Four types of bolted flange piping joints.

with an oxyacetylene torch. This causes the molten metal to fill the few thousandths of an inch annular space between the pipe and the fitting.

## Unions

The union fittings are provided in piping systems to allow the piping to be taken down for repairs and alterations. Unions are available in many different materials and designs to withstand a wide range of pressures and temperatures. Figure 6-42 shows some commonly used types of unions/threaded pipe connectors. The union is most commonly used for joining piping up to 2 inches in size.

## Flared Fittings

Flared fittings are commonly used in tubing lines. These fittings provide safe, strong, dependable connections without the necessity of threading, welding, or soldering the tubing. Flared fittings are made of steel, aluminum alloy, or

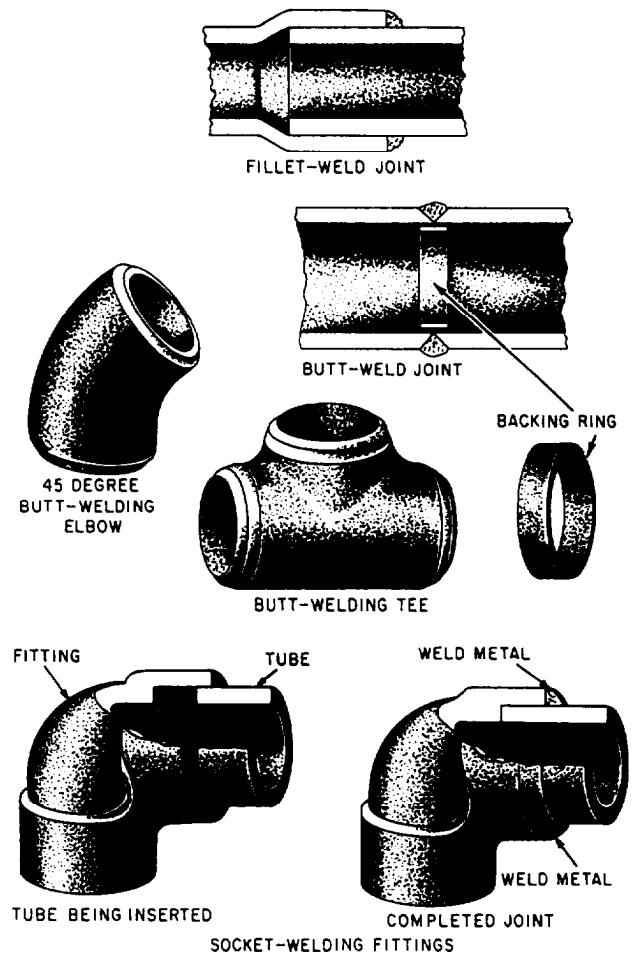

Figure 6-40.—Various types of welded joints.

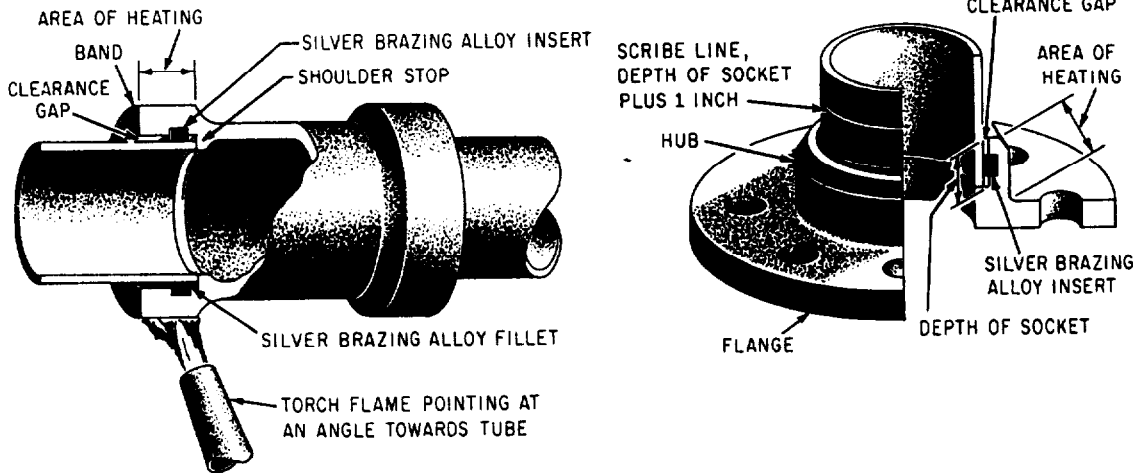

Figure 6-41.—Silver-brazed joints.

bronze. Do not mix materials when using these fittings. For example, for steel tubing use only steel fittings and for copper or brass tubing use only bronze fittings. Figure 6-43 shows the most common types of flared fittings.

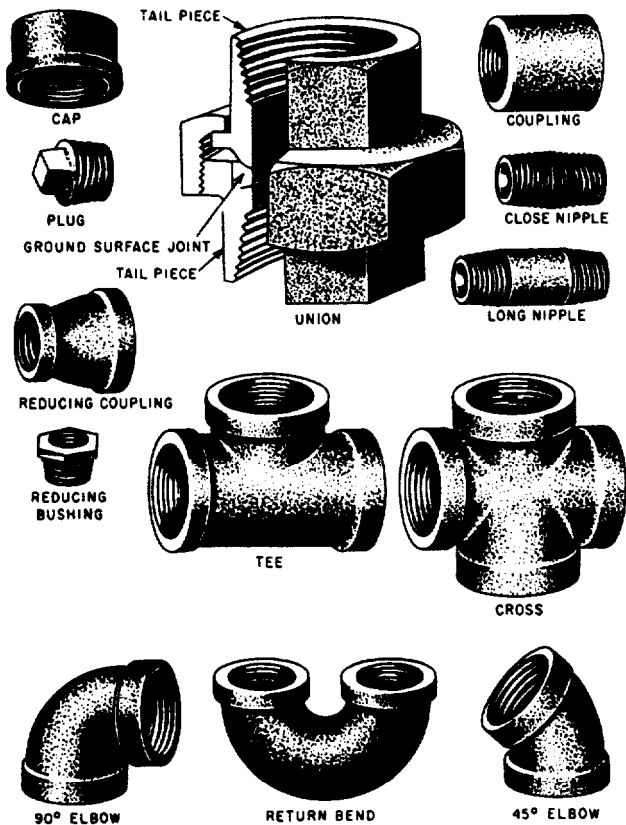

Figure 6-42.—Unions/threaded pipe connectors.

|  |  |  |
|--|--|--|
| <p>ELBOW</p> <p>FLARED TUBE AND PIPE THREAD 90°</p>    | <p>ELBOW</p> <p>FLARED TUBE AND PIPE THREAD 45°</p>    | <p>ELBOW</p> <p>FLARED TUBE 90°</p>                  |
| <p>TEE</p> <p>FLARED TUBE</p>                          | <p>TEE</p> <p>FLARED TUBE PIPE THREAD ON SIDE</p>      | <p>TEE</p> <p>FLARED TUBE PIPE THREAD ON RUN</p>     |
| <p>CROSS</p> <p>FLARED TUBE</p>                        | <p>UNION</p> <p>FLARED TUBE</p>                        | <p>NIPPLE</p> <p>FLARED TUBE AND PIPE THREAD</p>     |
| <p>UNION</p> <p>FLARED TUBE BULKHEAD AND UNIVERSAL</p> | <p>ELBOW</p> <p>FLARED TUBE BULKHEAD UNIVERSAL 90°</p> | <p>TEE</p> <p>FLARED TUBE BULKHEAD AND UNIVERSAL</p> |

Figure 6-43.—Flared-tube fittings.

## Flareless Fittings

Flareless fittings (figs. 6-44 and 6-45) are suitable for use in hydraulic service and air service systems at a maximum operating pressure of 3000 psi and a maximum operating temperature of 250°F. Flareless fittings are installed to conserve space and to reduce weight, installation time, and system cleaning time. Do not use flareless fittings if you do not have enough space to properly tighten the nuts or if you have to remove the equipment or piping for access to the fittings. An exception to this rule is a gauge board. It is designed so it may be removed as a unit for repairs or alterations. Do not use flareless fittings where you cannot easily deflect the piping to permit assembly and disassembly.

Before assembly, ensure the tubing end is square, concentric, and free of burrs. For an effective fitting, be sure the cutting edge of the sleeve or ferrule bites into the periphery of the tube; you can do this by presetting the ferrule.

## FLANGE SAFETY SHIELDS

A fuel fire in the MER or an AMR can be caused by a leak at a fuel oil or lube oil pipe flange connection. Even the smallest leak can spray fine droplets of oil on nearby hot surfaces. To reduce this possibility, FLANGE SAFETY SHIELDS are provided around piping flanges of inflammable liquid systems, especially in areas where the fire hazard is apparent. The spray shields are usually made of aluminized glass cloth and are simply wrapped and wired around the flange.

## PIPE HANGERS

Pipe hangers and supports are designed and located to support the combined weight of the

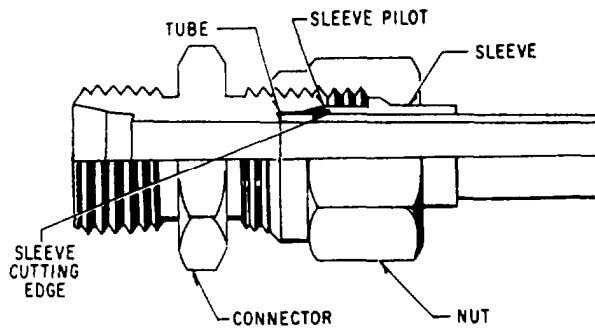
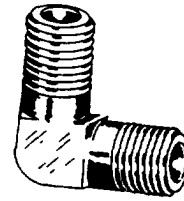

Figure 6-44.—Double-male flareless fitting.

## ELBOW



FLARELESS TUBE 90°

Figure 6-45.—Typical flareless fitting.

piping, fluid, and insulation. They absorb the movements imposed by thermal expansion of the pipe and the motion of the ship. The pipe hangers and supports prevent excessive vibration of the piping and resilient mounts or other materials. They are used in the hanger arrangement to break all metal-to-metal contact to lessen unwanted sound transmissions.

One type of pipe hanger you need to become familiar with is the variable spring hanger. This is used to support the ship's bleed air piping. It provides support by directly compressing a spring or springs. The loads carried by the hangers are equalized by adjustment of the hangers when they are hot. These hangers have load scales attached to them with a traveling arm or pointer that moves in a slot alongside the scale. This shows the degree of pipe movement from cold to hot. The cold and hot positions are marked on the load scale. You should check the hangers when they are hot to ensure that the pointers line up with the hot position on the load scales. You can adjust hangers that are out of position by loosening the jam nut on the hanger rod and turning the adjusting bolt of the hanger.

## INSPECTIONS AND MAINTENANCE

Reasonable care must be given to the various piping assemblies as well as to the units connected to the piping systems. Unless the piping system is in good condition, the connected units of machinery cannot operate efficiently and safely. You should be familiar with all the recommended maintenance procedures and observe the safety precautions when working on piping systems.

The most important factor in maintaining piping systems in satisfactory condition is keeping joints, valves, and fittings tight. To ensure this condition, you need to make frequent tests and inspections.

Piping should be tested at the frequency and test pressure specified following the PMS and the applicable equipment technical manual. Test pressure must be maintained long enough to show any leaks or other defects in the system.

Instruction manuals should be available and followed for the inspection and maintenance of piping systems and associated equipment; however, if the manufacturer's instruction manual is not available, you should refer to *Naval Ships' Technical Manual*, chapter 505, for details of piping inspection and maintenance.

## PIPING SYSTEM IDENTIFICATION MARKING

All piping should be marked to show the name of the service, destination (where possible), and direction of flow (fig. 6-46).

The name of the service and destination should be painted on by stencil or hand lettering, or by application of previously printed, stenciled, or lettered adhesive-backed tape. Lettering will be 1 inch high for a 2-inch or larger outside diameter bare pipe or insulation. For smaller sizes, lettering size may be reduced or label plates attached by wire or other suitable means.

Direction of flow will be indicated by an arrow 3 inches long pointing away from the lettering. For reversible flow, arrows are to be shown on each end of the lettering.

Black is used for lettering and arrows. However, on dark-colored pipe (including oxygen piping), white is used.

Markings will be applied to piping in conspicuous locations, preferably near the control valves and at suitable intervals so every line will have at least one identification marking in each compartment through which it passes. Piping in cabins and officers' wardrooms will not normally be marked.

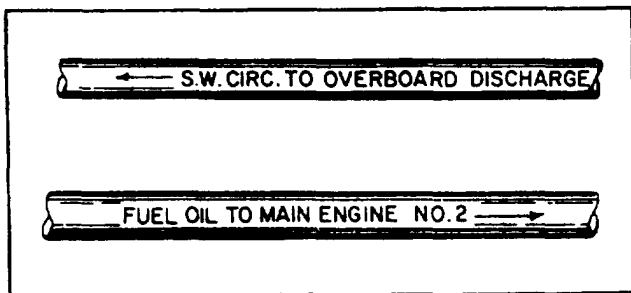

Figure 6-46.—Pipe markings.

## PACKING AND GASKET MATERIAL

Packing and gasket materials are required to seal joints in steam, water, gas, air, oil, and other lines and to seal connections that slide or rotate under normal operating conditions. There are many types and forms of packing and gasket materials available commercially.

## PACKING AND GASKET SELECTION

To simplify the selection of packing and gasket materials commonly used in naval service, the Naval Sea Systems Command has prepared a packing and gasket chart, Mechanical Standard Drawing B-153 (see fig. 6-47 at the end of this chapter). It shows the symbol numbers and the recommended applications for all types and kinds of packing and gasket materials.

The symbol number used to identify each type of packing and gasket has a four-digit number. (See List of Materials in fig. 6-47.) The first digit shows the class of service with respect to fixed and moving joints; the numeral 1 shows a moving joint (moving rods, shafts, valve stems), and the numeral 2 shows a fixed joint (flanges, bonnets). The second digit shows the material of which the packing or gasket is primarily composed— asbestos, vegetable fibre, rubber, metal, and so forth. The third and fourth digits show the different styles or forms of the packing or gasket made from the material.

Practically all shipboard packing and gasket problems can be solved by selection of the correct material from the listings on the packing and gasket chart. The following examples show the kind of information that you can get from the packing and gasket chart.

Suppose you are required to repack and install a valve in a 150-psi seawater service system. Refer to figure 6-47, the packing and gasket chart. Under the subhead Symbols and Specifications for Equipments, Piping and Independent Systems, you find that symbol 1103 indicates a suitable material for repacking the valve. Notice that the first digit is numeral 1, indicating that the material is for use in a moving joint. Under the List of Materials, you find the packing is asbestos rod, braided.

For installing the valve, you need proper gaskets. By use of the same subhead, you find that symbols 2150, 2151 type II, 2152, and 2290 type II are all suitable for installing the valve. Notice that the first digit is numeral 2, which indicates that it is designed for fixed joints. Again, by

referring to the List of Materials, you can determine the composition of the gasket.

Besides the Naval Ship Systems Command drawing, most ships have a packing and gasket chart made up specifically for each ship. The shipboard chart shows the symbol numbers and the sizes of packing and gaskets required in the ship's piping system, machinery, and hull fittings.

### PACKING OF MOVING JOINTS

Valves are components used to control the transfer of liquids and gases through fluid

piping systems. Most valves have moving joints between the valve stem and the bonnet. When fluid is on one or both sides of a moving joint, the joint may leak. Sealing the joint prevents this leakage. Sealing a moving joint presents a problem because the seal must be tight enough to prevent leakage, yet loose enough to let the valve stem turn without binding. Packing is the most common method of sealing a moving joint.

Packing is a sealing method that uses bulk material (packing) that is reshaped by compression to effectively seal a moving joint.

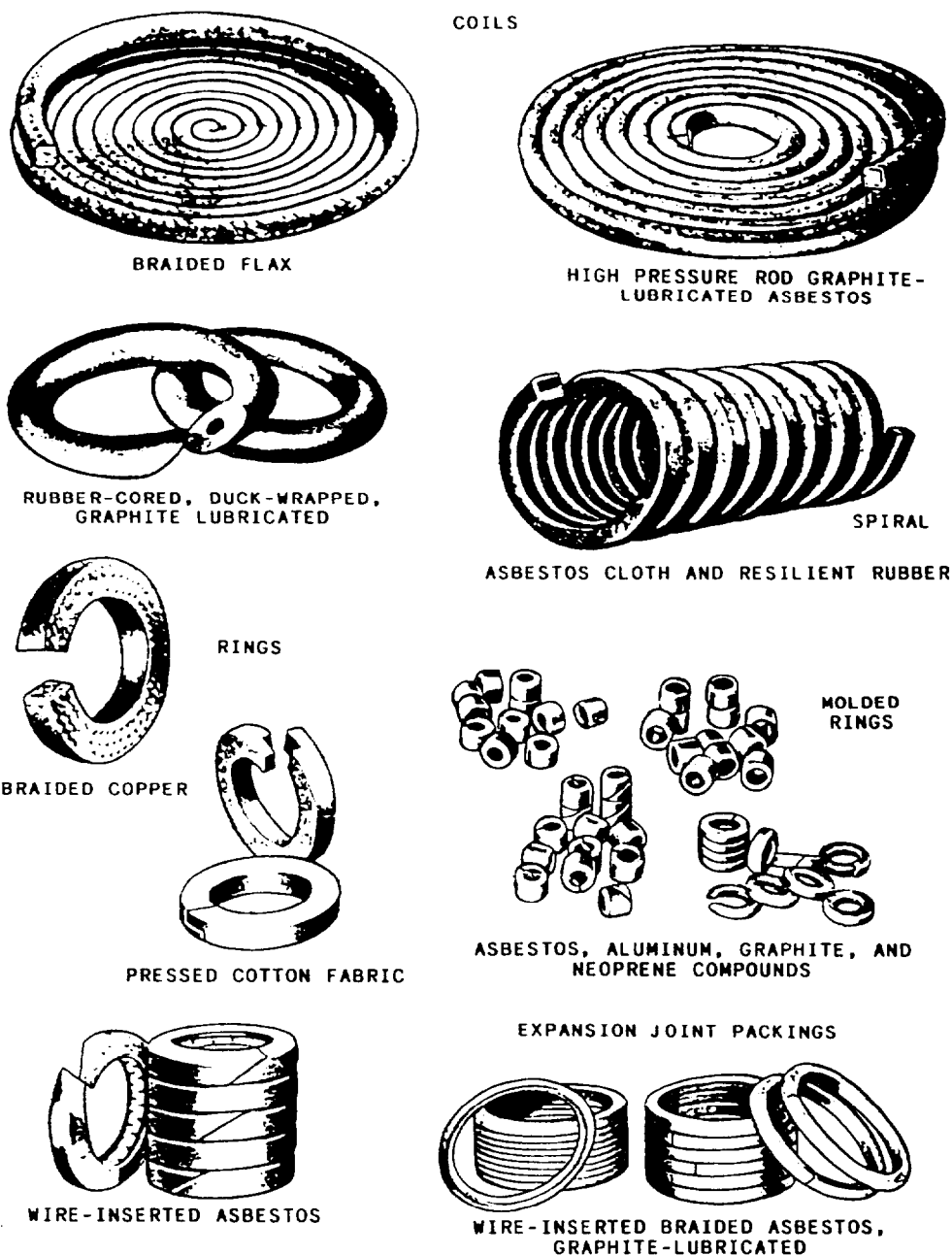

Figure 6-48.—Types of packing.

Figure 6-48 shows several types of packing in common use today.

Packing is inserted in STUFFING BOXES that have annular chambers located around valve stems and rotating shafts. The packing material is compressed to the necessary extent

and held in place by gland nuts or other devices.

A corrugated ribbon packing has been developed for universal use on valves. This packing comes in four widths (1 inch, 3/4 inch, 1/2 inch, and 1/4 inch) and is easily cut to length, rolled on the valve stem, and pushed into the stuffing box to form a solid, endless packing ring when compressed (fig. 6-49). Corrugated ribbon packing is suitable for use in systems of high temperatures (up to 1200°F and 2000 psi). It is easily removed since it does not harden.

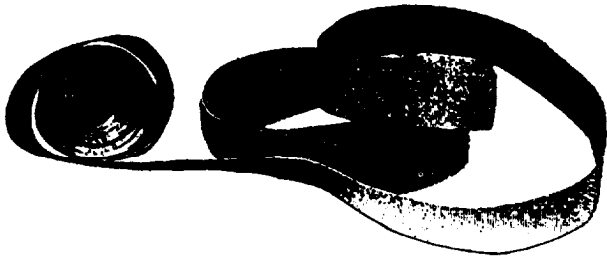

Figure 6-49.—Corrugated ribbon packing.

### PACKING OF FIXED JOINTS

Figure 6-50 shows gasket material used for fixed joints. At one time, fixed joints could be satisfactorily sealed with gaskets of compressed asbestos sheet packing (view A of fig. 6-50). Today the 15 percent rubber content of the

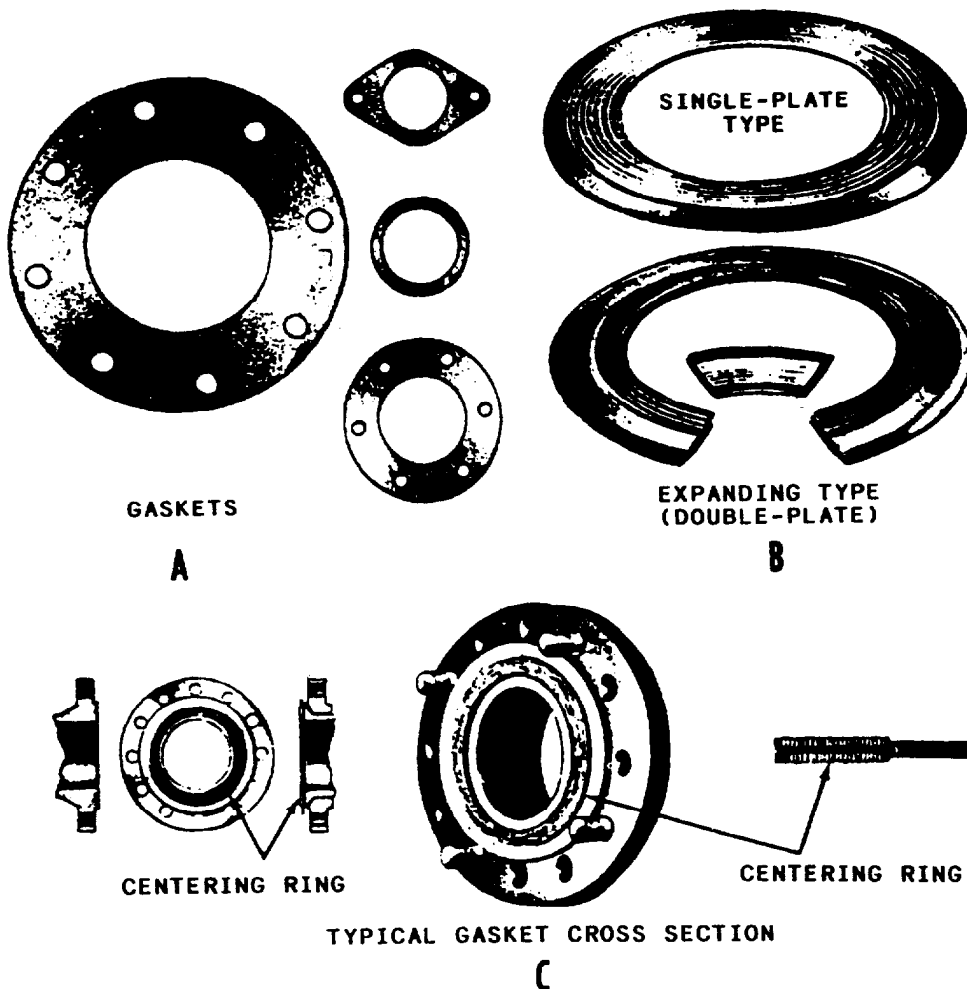

Figure 6-50.—Fixed-joint gaskets. A. Sheet asbestos gaskets. B. Serrated-face metal gaskets. C. Spiral-wound, metallic-asbestos gaskets.



packing makes it unsatisfactory for modern, high-temperature, high-pressure equipment. Two types of gaskets (metallic or semimetallic) are in use in present day high-temperature and high-pressure installations. Gaskets of corrugated copper or of asbestos and copper are sometimes used on low- and medium-pressure lines.

Serrated-face metal gaskets (view B of fig. 6-50) made of steel, Monel, or soft iron have raised serrations to make a better seal at the piping flange joints. These gaskets have resiliency. Line pressure forces the serrated faces tighter against the adjoining flange. The gaskets shown are of two variations.

Spiral-wound, metallic-asbestos gaskets (view C of fig. 6-50) are made of interlocked strands of preformed corrugated metal and asbestos strips, spirally wound together (normally called the FILLER), and a solid metal outer or centering ring (normally called the RETAINING RING).

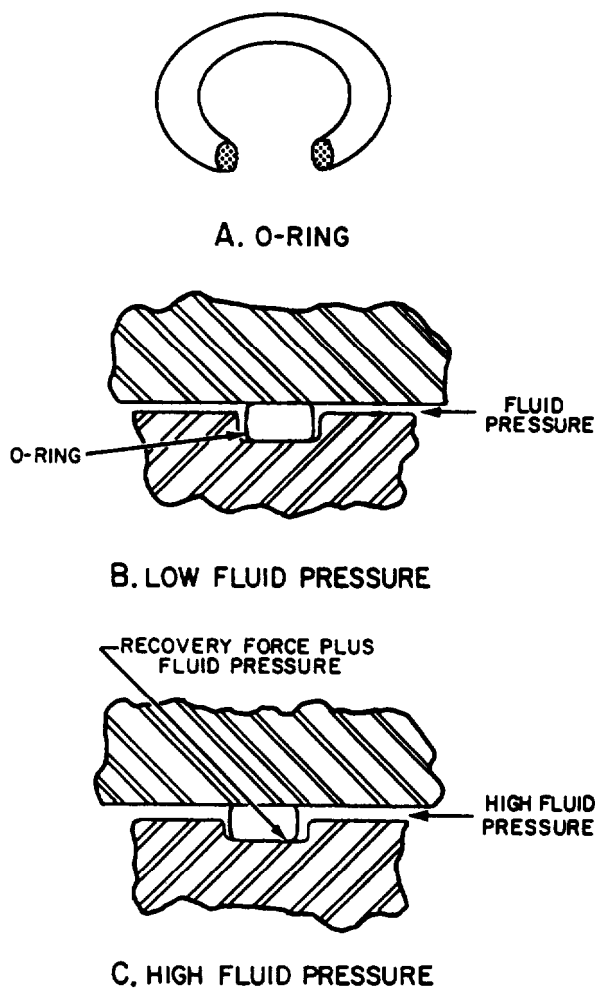

Figure 6-51.—O-ring seal with two cross-sectional views.

The centering ring is used as a reinforcement to prevent blowouts. The filler piece is replaceable. When renewing a gasket, you should remove this piece from the retaining metal ring and replace it with a new filler. Do not discard the solid metal retaining outer or centering ring unless it is damaged. You can compress the gaskets to the thickness of the outer or centering ring.

When renewing a gasket in a flange joint, you must exercise special precautions when breaking the joint, particularly in steam and hot water lines, or in saltwater lines that have a possibility of direct connection with the sea. Be sure to observe the following precautions:

1. No pressure is on the line.
2. The line pressure valves, including the bypass valves, are firmly secured, wired closed, and tagged.
3. The line is completely drained.
4. At least two flange-securing bolts and nuts diametrically opposite remain in place until the others are removed, then slackened to allow breaking of the joint, and removed after the line is clear.
5. Precautions are taken to prevent explosions or fire when breaking joints of flammable liquid lines.
6. Proper ventilation is ensured before joints are broken in closed compartments.

These precautions may prevent serious explosions, severe scalding of personnel, or flooding of compartments. You should thoroughly clean all sealing and bearing surfaces for the gasket replacement. Check the gasket seats with a surface plate, and scrape as necessary. This affords uniform contact. Replace all damaged bolt studs and nuts. In flange joints with raised faces, the edges of gaskets may extend beyond the edge of the raised face.

## O-RINGS

Another method of preventing leakage in fluid systems is by use of O-ring seals. Figure 6-51 shows an O-ring seal with two cross-sectional views. An O-ring is a doughnut-shaped, circular seal (view A of fig. 6-51) that is usually a molded rubber compound. An O-ring seal has an O-ring mounted in a groove or cavity (usually called a gland).

When the gland is assembled (view B of fig. 6-51), the O-ring cross section is compressed. When installed, the compression of the O-ring

cross section enables it to seal low fluid pressures. The greater the compression, the greater is the fluid pressure that can be sealed by the O-ring. The pressure of the O-ring against the gland walls equals the pressure caused by the recovery force of the compressed O-ring plus the fluid pressure.

The fluid pressure against the walls of the gland and the stiffness of the O-ring prevent fluid from leaking past the O-ring. If the downstream clearance is large, the O-ring is forced into this clearance (view C of fig. 6-51). The stiffness of the O-ring material prevents the O-ring from being forced completely through the downstream clearance unless that clearance is abnormally large or the pressure is excessive.

O-rings are commonly used for sealing because of their simplicity, ruggedness, low cost, ease of installation, ease of maintenance, and their effectiveness over wide pressure and temperature ranges.

Failure of an O-ring can sometimes begin with the removal of an old O-ring. If you incorrectly remove an O-ring with pointed or sharp tools, you can scratch or dent critical surface finishes that can result in seal failure.

Before installing a new O-ring, inspect the sealing surfaces for any abrasions and wipe them free of any dust, dirt, or other contaminants. Before installation, inspect the O-ring for any damage. If faulty, discard it.

When you install the O-ring, lubricate it. In most cases it is already coated with the system fluid or petrolatum grease. Do not stretch the O-ring more than twice its original size during installation, and do not roll or twist it into place. This may leave a permanent twist in the O-ring and reduce its effectiveness and shorten its life.

When installing an O-ring, take extreme care to avoid forcing it over sharp edges, corners, and threaded sections. You should use some type of sleeve or cover to avoid damaging the O-ring.

## FASTENERS

The proper use of fasteners is very important and cannot be overemphasized. Many shipboard machinery casualties have resulted from fasteners that were not properly installed. Machinery vibration, thermal expansion, and thermal contraction will loosen the fasteners. At sea, loosening effects are increased by the pitch and roll of the ship. You are familiar with such standard fasteners as nuts, bolts, washers, wingnuts, and screws. In chapter 3 we discussed how nuts and bolts (threaded

fasteners) are torqued to the manufacturer's specifications and the lockwire method of ensuring that certain types of fasteners will not come loose. In this section of chapter 6 we will discuss some of the new developments in fastener technology, such as the various types of locknuts, which you may not be familiar with.

## THREADED LOCKING DEVICES

An important part of fastener technology has included the development of several methods for locking mated threads of fasteners. Many of the latest methods include the locking device or method as an integral part of the fastener assembly and are referred to as self-locking nuts or bolts. Self-locking fasteners are more expensive than some older methods but compare favorably in cost with pin or wiring methods.

### Length of Protrusion

Male threads on threaded fasteners, when installed and tightened, will protrude the distance of at least one thread length beyond the top of the nut or plastic locking ring. Excessive protrusion is a hazard, particularly where necessary clearances, accessibility, and safety are important. Where practicable, the number of threads protruding should not exceed five. In no case should thread protrusion exceed 10 threads unless specifically approved by the work supervisor. (This is the one-to-ten rule.)

Where screw threads are used for setting or adjusting (such as valve stem packing glands and travel stops) or where installed threaded fasteners do not strictly follow the one-to-ten rule but have given satisfactory service, the rule does not apply. An example of an acceptable existing installation would be where a male thread is flush with the top of a nut or where more than 10 threads protruding is of no foreseeable consequence.

### Repair of Damaged Threads

You can remedy damaged external threads by replacing the fastener. In large equipment castings you must repair damaged internal threads to save the part. You can repair internal threads by re-drilling the damaged thread; clean and either install a solid wall insert or tap for a helical coil insert. These inserts, in effect, return the tapped hole to its original size so it takes the original mating fastener.

## LOCKNUTS

Locknuts are used in special applications where you want to ensure that the components joined by the fasteners will not loosen. Two types of locknuts are in common use. The first type applies pressure to the bolt thread and can be used where frequent removal may be required. The second type deforms the bolt thread and is used only where frequent removal is unnecessary. The first type includes plastic ring nuts, nylon insert nuts, jam nuts, spring nuts, and spring beam nuts. The second type includes distorted collar nuts and distorted thread nuts; they are not commonly found in gas turbine equipment and will not be covered in this section.

### Plastic Ring Nuts

Plastic ring nuts (fig. 6-52) deform the plastic insert when they are installed. The resilient plastic material is forced to assume the shape of the mating threads, creating large frictional forces.

### Nylon Insert Nuts

Nylon insert nuts have plastic inserts (plugs) that do not extend completely around the threads.

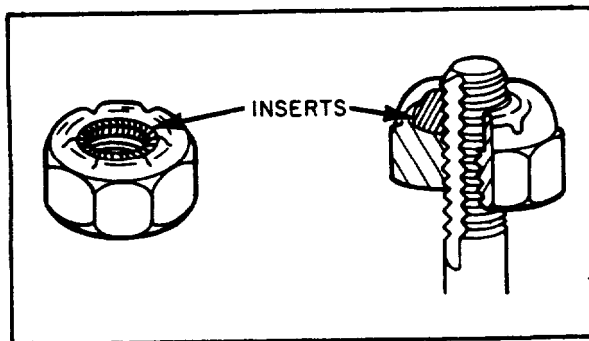

Figure 6-52.—Plastic ring nut.

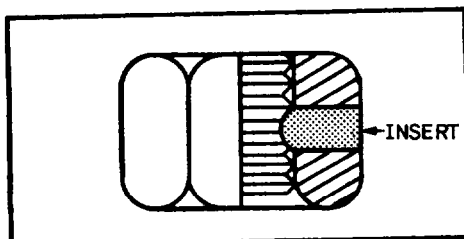

Figure 6-53.—Nylon insert nut.

They force the nut to the side, cocking it slightly. This produces frictional forces on one side of the bolt thread. Although the plastic insert locks without seating, proper torque applied to the nut stretches the bolt, creating clamping forces that add to the locking abilities of the nut. Before reusing nylon insert nuts (fig. 6-53), check the inserts. If worn or torn, discard the nut. Install the nut (on clean lightly lubricated threads) finger tight. If you can install the nut to the point where the bolt threads pass the insert without a wrench, discard the nut and use a new one.

### Jam Nuts

You should install jam nuts (fig. 6-54) with the thinner nut to the working surface and the thicker nut to the outside. The thin nut is deformed by the wider nut and pressed against the working surface and threads.

### Spring Nuts

Spring nuts (fig. 6-55) lock by the side grip on the bolt. When tightened, the spring nut

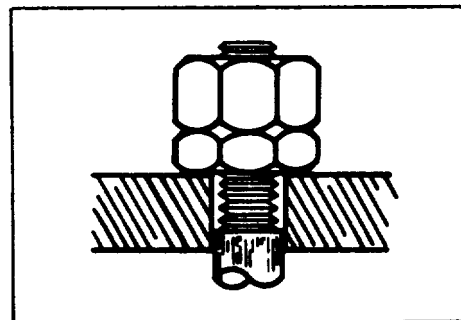

Figure 6-54.—Jam nuts.

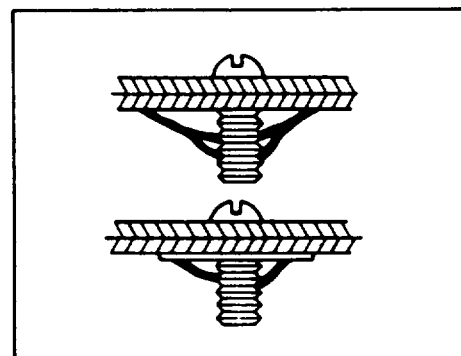

Figure 6-55.—Spring nuts.

flattens, or straightens, a spring section. Many types of spring nuts use curved metal springs, bellows, and coil springs. All spin on and off without locking until the pressure against the working surface straightens the spring.

You should always consult equipment manuals for the proper torque value. Be sure threads are always clean and lightly lubricated with the proper lubrication. Discard any with damaged threads.

### Spring Beam Nuts

Spring beam nuts (fig. 6-56) are formed with a light taper in the threads toward the upper portion of the nut. Slots are cut in the outer portion, forming segments that can be forced outward when the nut is installed. Elastic reaction causes the segments to push inward, gripping the bolt. Like the nylon insert nut, this nut does not deform the bolt threads and can be used on frequently removed items. If you can thread the nut past the deflection segments without a wrench, discard the nut and replace it with a new one.

### LOCKWASHERS

Many installations on board naval ships still use lockwashers to prevent threaded fasteners from loosening. If loosening has not been a problem, you may replace worn lockwashers with an identical type; however, if loosening has been a problem, you should use self-locking fasteners instead of lockwashers.

The most common lockwasher used is the helical spring washer. Other types are the conical and toothed tab.

### Helical Spring Lockwashers

The helical spring lockwasher (split ring) (fig. 6-57) is flattened when the bolt is torqued

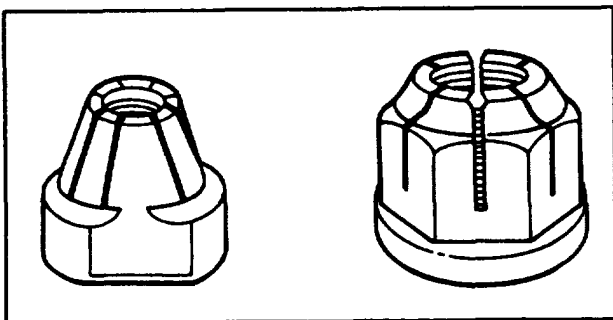

Figure 6-56.—Spring beam nuts.

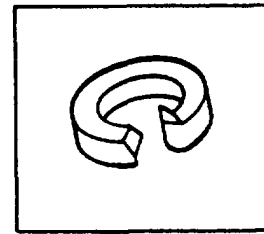

Figure 6-57.—Helical spring lockwasher.

down. When torqued, it acts as a flat washer contributing normal friction for locking the screw or bolt and the working surface; it also maintains the tension on the bolt. Because of the helical spring lockwasher's small diameter, it is usually not used on soft materials or with oversized or elongated holes.

### Curved or Conical Spring Lockwashers

Curved or conical spring lockwashers have almost the same properties as the helical spring lockwasher. They provide a constant tension on the bolt or screw when loosened. The tension produced is usually less than that produced by the helical spring lockwasher. Like any locking device relying on tension, spring lockwashers may loosen on shock loading. When the bolt stretches more than the spring distortion from the shock loading, the washer serves no further purpose. Recheck the washer, where possible, when shock is sufficient to suspect loosening. Some spring lockwashers have teeth on the outer edge. These teeth do not aid in locking, but they prevent side slippage and turning.

### Toothed Lockwashers

Toothed lockwashers (fig. 6-58) have teeth that are twisted or bent to prevent loosening. Cutting

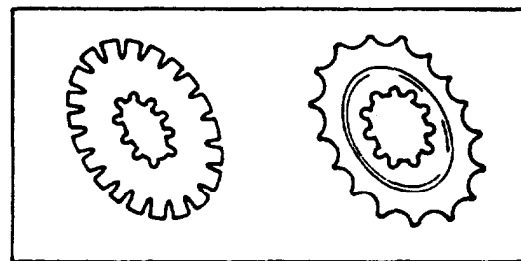

Figure 6-58.—Toothed lockwashers.

edges engage both working surfaces on the nut and bolt or screw. Some have teeth on the inner diameter for applications where teeth projecting beyond the nut are not desired. The most common type have teeth on the outer diameter. Washers with teeth on both inside and outside diameters are used for soft materials and oversize holes. The teeth are twisted, so as the nut is installed and torqued down, the rim of the washer supports the pressure. Any backing off of the nut or bolt releases tension that allows the teeth to dig into the working surfaces of the nut and bolt.

## INSULATION

The purpose of insulation is to retard the transfer of heat FROM piping that is hotter than the surrounding atmosphere or TO piping that is cooler than the surrounding atmosphere. Insulation helps to maintain the desired temperatures in all systems. In addition, it prevents sweating of piping that carries cool or cold fluids. Insulation also serves to protect personnel from being burned by coming in contact with hot surfaces. Piping insulation represents the composite piping covering which consists of the insulating material, lagging, and fastening. The INSULATING MATERIAL offers resistance to the flow of heat; the LAGGING, usually of painted canvas, is the protective and confining covering placed over the insulating materials; and the FASTENING attaches the insulating material to the piping and to the lagging.

Insulation covers a wide range of temperatures, from the extremely low temperatures of the refrigerating plants to the very high temperatures of the ship's waste heat boilers. No one material could possibly be used to meet all the conditions with the same efficiency.

### INSULATION MATERIALS

The following QUALITY REQUIREMENTS for the various insulating materials are taken into consideration by the Navy in the standardization of these materials:

1. Low heat conductivity
2. Noncombustibility
3. Lightweight
4. Easy molding and installation capability
5. Moisture repellent

6. Noncorrosive, insoluble, and chemically inactive
7. Composition, structure, and insulating properties unchanged by temperatures at which it is to be used
8. Once installed, should not cluster, become lumpy, disintegrate, or build up in masses from vibration
9. Verminproof
10. Hygienically safe to handle

Insulating material is available in preformed pipe coverings, blocks, batts, blankets, and felts. Refer to *Naval Ships' Technical Manual*, Chapter 635, "Thermal, Fire, and Acoustic Insulation," for detailed information on insulating materials, their application, and safety precautions.

The insulating cements are comprised of a variety of materials, differing widely among themselves as to heat conductivity, weight, and other physical characteristics. Typical of these variations are the asbestos substitute cements, diatomaceous cements, and mineral and slag wool cements. These cements are less efficient than other high-temperature insulating materials, but they are valuable for patchwork emergency repairs and for covering small irregular surfaces (valves, flanges, joints, and so forth). Additionally, the cements are used for a surface finish over block or sheet forms of insulation, to seal joints between the blocks, and to provide a smooth finish over which asbestos substitute or glass cloth lagging may be applied.

### REMOVABLE INSULATION

Removable insulation will be found on the bleed air systems and waste heat boiler systems. Removable insulation is also installed in the following locations:

- Flange pipe joints adjacent to machinery or equipment that must be broken when units are opened for inspection or overhaul
- Valve bonnets of valves larger than 2 inches internal pipe size (IPS) that operate at 300 psi and above or at 240°F and above
- All pressure-reducing and pressure-regulating valves, pump pressure governors, and strainer bonnets

## GENERAL INSULATION PRECAUTIONS

You should observe the following general precautions relative to the application and maintenance of insulation:

1. Fill and seal all air pockets and cracks. Failure to do this will cause large losses in the effectiveness of the insulation.
2. Seal the ends of the insulation and taper off to a smooth, airtight joint. At joint ends or other points where insulation is liable to be damaged, use sheet metal lagging over the insulation. You should cuff flanges and joints with 6-inch lagging.
3. Keep moisture out of all insulation work. Moisture is an enemy of heat insulation just as much as it is in electrical insulation. Any dampness increases the conductivity of all heat-insulating materials.
4. Insulate all hangers and other supports at their point of contact from the pipe or other unit they are supporting; otherwise, a considerable quantity of heat will be lost via conduction through the support.
5. Keep sheet metal covering bright and unpainted unless the protective surface has been damaged or has worn off. The radiation from bright-bodied and light-colored objects is considerably less than from rough and dark-colored objects.
6. Once installed, heat insulation requires careful inspection, upkeep, and repair. Replace lagging and insulation removed to make repairs as carefully as when originally installed. When replacing insulation, make certain that the replacement material is of the same type as had been used originally.
7. Insulate all flanges with easily removable forms. These forms are made up as pads of insulating material, wired or bound in place, and the whole covered with sheet metal casings, which are in halves.
8. Asbestos Control: Inhalation of excessive quantities of asbestos fibre or filler can produce severe lung damage in the form of disabling or fatal fibrosis of the lungs. Asbestos has also been found to be a casual factor in the development of cancer of the membrane lining the chest and abdomen. Lung damage and disease usually develop slowly and often do not become apparent until years after the initial exposure. If your plans include a long and healthy Navy retirement, you have no business doing asbestos lagging rip-out without proper training, protective clothing, and supervision. Most systems of today's modern Navy have been purged of asbestos and an asbestos substitute material installed in its place. Some of the older class vessels may still have some asbestos insulation installed. Use caution when handling lagging and insulation from these vessels. If in doubt, contact your supervisor and request the medical department conduct a survey of the material in question.

## SUMMARY

In this chapter we have described some of the basic types of piping system components you find aboard ship. Aboard ship you will find a variety of pipes, tubing, and hose assemblies that have many uses in the engineering plant. To perform maintenance and repair on piping systems, you must familiarize yourself with the manufacturers' technical manuals, the ship's engineering operational sequencing system, the appropriate *Naval Ships' Technical Manual*, and the PMS for the individual system. The information in this chapter is intended to provide you with the basic knowledge of piping systems and how they are constructed. For more indepth information on piping systems and their components, refer to *NSTM*, chapter 505.

| SYMBOLS AND SPECIFICATIONS FOR EQUIPMENTS, PIPING, AND INDEPENDENT SYSTEMS |   |                            |                     |   |   |   |            |                                   |  |                                      |                 |   |   |
|--|---|----------------------------|---------------------|---|---|---|------------|-----------------------------------|--|--------------------------------------|-----------------|---|---|
| ITEM   | SERVICE   | SEE NOTE 3                 |                     | MOVING RODS AND SHFTS                             |   | SLIP JOINTS                                       |            | FIXED MECHANICAL JOINTS (GASKETS) |  | INDEPENDENT ITEMS AND SYSTEMS NOTE R | MATERIAL DESIGN |   |   |
|  |   | DESIGN PRESSURE PSIG (MPa) | MAX TEMP F (C)      | RECIP ROD   | ROTARY ROD  | VALVE STEM AND ROD                                | EXP JOINTS | * COND.                           |  |                                      |                 |   |   |
| 1  | 2   | 3                          | 4                   | 5   | 6   | 7   | 8          | 9                                 | 10   | 11                                   | 12              | 13  | 14  |
| 1  | SUPERHEATED HIGH PRESSURE   | 1500 (10.34)               | 1050 (566)          |   |   | 1111 MIL P 24503 (V)                              |            |                                   | MIL G 21032 TYPE II 2410 (D)   |                                      | 22              | AFF SYSTEM  | MIL G 22050                                     |
| 2  | SUPERHEATED HIGH AND LOW PRESSURE   | 600 (4.14)                 | 875 (468)           |   |   | 1104 1108 1111 MIL P 24503 (V)                    | 1108       |                                   | MIL G 21032 2410 (D) MIL G 16265   |                                      | 23              | BOILER BLOW DOWN  | MIL G 21032                                     |
| 3  | SATURATED HIGH PRESSURE   | 650 (448)                  | 495 (257)           | MIL P 24377 MIL A 24058 1430 (A)(B) 1433 (F)(B)   | MIL P 24377 MIL A 24058 1103 1430 (A)(B) 1700     | MIL P 24377 MIL A 24058 1103 1430 (A)(B) 1700     |            |                                   | MIL G 21032 2410 (D) MIL G 16265 2151 TYPE II (D) 2151 TYPE III          |                                      | 24              | BOILER CASING   | NOTE X  |
| 4  | SATURATED LOW PRESSURE  | 300 (2.07)                 | 420 (216)           | 1112 1430 (A)(B) 1433 (F)(B)                      | 1103 1700   | MIL P 24377 MIL A 24058 1103 1430 (A)(B) 1700     | 1108 1432  |                                   | MIL G 21032 2150 CLASS I 2151 TYPE II 2410 (D) 2151 TYPE II (D) 2152 (D) |                                      | 25              | BOILER SAFETY AND SUPERHEATER OUTLET VALVE                  | MIL G 21032                                     |
| 5  | BOILER FEED   | 1200 (8.27)                | 475 (246)           | MIL P 24377 MIL A 24058 1103 1430 (A)(B) 1700     | MIL P 24377 MIL A 24058 1103 1430 (A)(B) 1700     | MIL P 24377 MIL A 24058 1103 1430 (A)(B) 1700     |            |                                   | MIL G 21032 TYPE II  |                                      | 26              | CHEMICAL DRAINS   | MIL G 21032 2473                                |
| 6  | PROPULSION PLANT SATURATED FEED   | 2050 (14.13)               | 300 (149)           | MIL P 24377 MIL A 24058 1103 1430 (A)(B) 1700     | MIL P 24377 MIL A 24058 1103 1430 (A)(B) 1700     | MIL P 24377 MIL A 24058 1103 1430 (A)(B) 1700     |            |                                   | MIL G 21032  |                                      | 27              | CO <sub>2</sub> SCRUBBERS                                   | MIL G 22050                                     |
| 7  | HOT, FRESH, SALT BRINE CONDENSATE, ETHYLENE GLYCOL SOLUTION, AND ELECTRONIC COOLING | 150 (1.03)                 | 250 (121)           | MIL P 24377 MIL A 24058 1103 1430 (A)(B) 1700     | MIL P 24377 MIL A 24058 1103 1430 (A)(B) 1700     | MIL P 24377 MIL A 24058 1103 1430 (A)(B) 1700     |            | MIL P 15742 1435 GRADE A NOTE H   | 2150 (E) 2351 CLASS 5 (AA) 2353 CLASS 4                                  |                                      | 28              | GAS TURBINE EXHAUSTS  | MIL G 21032 2150 TO 750 F                       |
| 8  | COLD, FRESH, SALT BRINE CHILLED POTABLE, AND ETHYLENE GLYCOL SOLUTION               | 150 (1.03)                 | 150 (65.6)          | MIL P 24377 MIL A 24058 1103 1430 (A)(B) 1700     | MIL P 24377 MIL A 24058 1103 1430 (A)(B) 1700     | MIL P 24377 MIL A 24058 1103 1430 (A)(B) 1700     |            | MIL P 15742 1435 GRADE A NOTE H   | 2351 CLASS 5 2353 CLASS 4  |                                      | 29              | HALON 1301  | MIL G 21032                                     |
| 9  | SEAWATER  | 400 (2.76)                 | 150 (65.6)          | MIL P 24377 MIL A 24058 1103 1430 (A)(B) 1700     | MIL P 24377 MIL A 24058 1103 1430 (A)(B) 1700     | MIL P 24377 MIL A 24058 1103 1430 (A)(B) 1700     |            | MIL P 15742 1435 GRADE A          | 2150 2151 TYPE II 2152 2290 TYPE II                                      |                                      | 30              | INTERNAL COMBUSTION ENGINE EXHAUSTS                         | 1108 1111 2150 CLASS I NOTE M                   |
| 10   | DIESEL FUEL MARINE  | 350 (2.41)                 | 225 (107)           | MIL P 24377 MIL A 24058 1103 1430 (A)(C) 1720 (G) | MIL P 24377 MIL A 24058 1103 1430 (A)(C) 1720 (G) | MIL P 24377 MIL A 24058 1103 1430 (A)(C) 1720 (G) |            |                                   | MIL G 21032 TYPE II  |                                      | 31              | INCINERATOR   | MIL G 21032 2150 TO 750 F                       |
| 11   | JP 5  | 300 (1.38)                 | 100 (38)            | MIL P 24377 MIL A 24058 1103 1430 (A)(C) 1720 (G) | MIL P 24377 MIL A 24058 1103 1430 (A)(C) 1720 (G) | MIL P 24377 MIL A 24058 1103 1430 (A)(C) 1720 (G) |            |                                   | MIL G 21032 TYPE II  |                                      | 32              | MAGAZINE SPRINKLING (WET)                                   | 2351 2353                                       |
| 12   | GASOLINE  | 150 (1.03)                 | 150 (65.6)          | MIL P 24377 MIL A 24058 1103 1430 (A)(C) 1720 (G) | MIL P 24377 MIL A 24058 1103 1430 (A)(C) 1720 (G) | MIL P 24377 MIL A 24058 1103 1430 (A)(C) 1720 (G) |            |                                   | MIL G 21032 TYPE II  |                                      | 33              | PLUMBING DRAINS OR VENTS TO 150 F                           | 2351 CLASS I OR CLASS 5                         |
| 13   | LUBRICATING OIL   | 150 (1.03)                 | 250 (121)           | MIL P 24377 MIL A 24058 1103 1430 (A)(C) 1720 (G) | MIL P 24377 MIL A 24058 1103 1430 (A)(C) 1720 (G) | MIL P 24377 MIL A 24058 1103 1430 (A)(C) 1720 (G) |            |                                   | MIL G 21032 TYPE II  |                                      | 34              | REDUCTION GEAR VENTS  | 2151  |
| 14   | HYDRAULIC FLUID PETROLEUM BASE  | 3000 (20.68)               | 180 (82)            | MIL P 24377 MIL A 24058 1103 1430 (A)(C) 1720 (G) | MIL P 24377 MIL A 24058 1103 1430 (A)(C) 1720 (G) | MIL P 24377 MIL A 24058 1103 1430 (A)(C) 1720 (G) |            |                                   | MIL G 21032 TYPE II  |                                      | 35              | RUDDER STOCK  | 1260 NOTE Y MIL P 24377                         |
| 15   | HYDRAULIC FLUID PHOSPHATE ESTER BASE  | 3000 (20.68)               | 180 (82)            | MIL P 24377 MIL A 24058 1103 1430 (A)(C) 1720 (G) | MIL P 24377 MIL A 24058 1103 1430 (A)(C) 1720 (G) | MIL P 24377 MIL A 24058 1103 1430 (A)(C) 1720 (G) |            |                                   | MIL G 21032 TYPE II  |                                      | 36              | SEAWATER WASHDOWN   | 2351  |
| 16   | HYDRAULIC FLUID WATER OR WATER GLYCOL   | 3000 (20.68)               | 180 (82)            | MIL P 24377 MIL A 24058 1103 1430 (A)(C) 1720 (G) | MIL P 24377 MIL A 24058 1103 1430 (A)(C) 1720 (G) | MIL P 24377 MIL A 24058 1103 1430 (A)(C) 1720 (G) |            |                                   | MIL G 21032 TYPE II  |                                      | 37              | SEWAGE COLLECTION HOLDING AND TRANSFER (CH)                 | 2351 CLASS I OR CLASS 5 2353 CLASS 2 OR CLASS 4 |
| 17   | REFRIGERANT FREQ. R1, R12, R22, R114  | 300 (2.07)                 | -85 +250 (-66 +121) | MIL P 24377 MIL A 24058 1103 1430 (A)(C) 1720 (G) | MIL P 24377 MIL A 24058 1103 1430 (A)(C) 1720 (G) | MIL P 24377 MIL A 24058 1103 1430 (A)(C) 1720 (G) |            |                                   | MIL G 21032 TYPE II  |                                      | 38              | SPRINKLING SYSTEM (DRY)                                     | 2351  |
| 18   | OXYGEN LOW PRESSURE   | 100 (0.69)                 | AMBIENT             | MIL P 24377 MIL A 24058 1103 1430 (A)(C) 1720 (G) | MIL P 24377 MIL A 24058 1103 1430 (A)(C) 1720 (G) | MIL P 24377 MIL A 24058 1103 1430 (A)(C) 1720 (G) |            |                                   | MIL G 21032 TYPE II  |                                      | 39              | STERN TUBE  | MIL P 24377                                     |
| 19   | AIR LOW PRESSURE  | 200 (1.38)                 | 550 (286)           | MIL P 24377 MIL A 24058 1103 1430 (A)(C) 1720 (G) | MIL P 24377 MIL A 24058 1103 1430 (A)(C) 1720 (G) | MIL P 24377 MIL A 24058 1103 1430 (A)(C) 1720 (G) |            |                                   | MIL G 21032 TYPE II  |                                      | 40              | TURBINE CASING (STEAM OR GAS)                               | MIL S 15204 TYPE C                              |
| 20   | AIR AND NITROGEN SERVICE AND CONTROL  | 150 (1.03)                 | 656                 | MIL P 24377 MIL A 24058 1103 1430 (A)(C) 1720 (G) | MIL P 24377 MIL A 24058 1103 1430 (A)(C) 1720 (G) | MIL P 24377 MIL A 24058 1103 1430 (A)(C) 1720 (G) |            |                                   | MIL G 21032 TYPE II  |                                      | 41              | WASTE WATER, OILY BILGE STRIPPING, CONTAMINATED DECK DRAINS | 2351 CLASS I OR CLASS 5 2353 CLASS 2 OR CLASS 4 |
| 21   |   |                            |                     |   |   |   |            |                                   | MIL G 21032 TYPE II  |                                      | 42              | WATERTIGHT CLOSURE DOGS AND HANDWHEEL SPINDLES              | 1425  |

| SYMBOLS AND SPECIFICATIONS FOR STRUCTURAL FIXED JOINTS—WATERTIGHT |   |                                      |   |                       |                      |   |  |  |                             |                                 |
|---|---|--------------------------------------|---|-----------------------|----------------------|---|--|--|-----------------------------|---------------------------------|
| FLANGES TO SHIPS STRUCTURE (EXCEPTING ITEMS 21 AND 22)            | FLANGES, STEAM PIPING TO SHIPS STRUCTURE.                             | FLANGES, PIPING TO FRESH WATER TANKS | FLANGES, TO WOOD AND METAL DECKS                          | ALUMINUM FAY SURFACES |                      | FLANGES, FITTINGS TO SHIP STRUCTURE OTHER THAN ITEMS 20 TO 25 | FLANGES, WATERTIGHT VENTILATING DUCTS. | PACKING OF LENSES IN AIRPORT FRAMES    | SEALANT FOR BOLTS IN PLATES | VENTILATION CLOSURES TYPES F, R |
| 20  | 21  | 22                                   | 23  | 24                    | 25                   | 26  | 27                                     | 28                                     | 29                          | 30                              |
| MIL S 8802  | SEE NOTE N<br>GASKETS BOLTS<br>2150 CLASS I<br>MIL P 24377<br>OR 2351 | 2353<br>(1/8 THICK)                  | TY C 1796<br>MIL S 8802<br>MIL S 24340<br>TYPE II CLASS 2 | NOTE U<br>MIL S 8802  | NOTE U<br>MIL S 8802 | 2353<br>MIL S 8802  | 2353<br>2351<br>2355<br>MIL G 22050    | TY C 1796<br>MIL S 8802<br>MIL C 18255 | MIL S 8802                  | 2353<br>MIL G 22050             |

| SYMBOLS AND SPECIFICATIONS FOR STRUCTURAL FIXED JOINTS—OIL AND FUEL TIGHTNESS. |   |                                  |                             |   |  |
|--|---|----------------------------------|-----------------------------|---|--|
| PROPELLER GLAND SEAL   | FLANGES, IN WAY OF FUEL, DIESEL FUEL MARINE, DIESEL, JP 5, AND LUBRICATING OIL. | FLANGES, SEA CHEST IN OIL TANKS. | SEALANT FOR BOLTS IN PLATES | GASKETS, FOR BOLTED MANHOLES AND PLATES | GASKETS, FOR DOGGED MANHOLES AND HATCHES |
| 38   | 39  | 40                               | 41                          | 42                                      | 43                                       |
| 2362   | MIL S 8802<br>2150 CLASS I<br>2250 TYPE I                                       | 250 CLASS I                      | MIL S 8802                  | 2250 TYPE I<br>MIL C 6183<br>CLASS I    | 2362<br>2366 CLASS 3                     |

| SYMBOLS AND SPECIFICATIONS FOR STRUCTURAL                    |                       |                                   |  |
|--|-----------------------|-----------------------------------|--|
| FLANGES, NON WATERTIGHT VENTILATING SYSTEMS (EXCEPT HEATERS) | ALUMINUM FAY SURFACES |                                   | GASKETS, FLAME RESISTING CLOSURES IN TURRETS |
| 48   | ALUMINUM TO ALUMINUM  | ALUMINUM TO OTHER METALS AND WOOD | 48   |
| 2363<br>(1/8 THICK)<br>2250                                  | NOTE U<br>MIL S 8802  | NOTE U<br>MIL S 8802              | 2363<br>ZZ R 765<br>CLASS 26 GRADE           |

GS3V1F0647A

Figure 6-47.—Application criteria for packings and gaskets.

| LIST OF MATERIALS |   |  |  |
|-------------------|---|--|--|
| CLASS OF JOINT    | STYLE OF PACKINGS AND GASKETS   | SYMBOL   | RELEVANT   |
|                   |   |  | ASBESTOS CONTAINING SPECIFICATION  |
| 15                | 16  | 17   | 18   |
| MOVING            | ASBESTOS ROD, BRAIDED<br>ASBESTOS ROD, BRAIDED, WIRE INSERTION<br>PLASTIC, NON-METALLIC, ASBESTOS AND WIRE JACKET<br>PLASTIC, NON-METALLIC, COIL FORM ± COTTON JACKET<br>PLASTIC, NON-METALLIC, COIL FORM, ASBESTOS AND ALLOY JACKET<br>PLASTIC, NON-METALLIC, COIL FORM, BRAIDED METAL JACKET<br>HYDRAULIC, CONICAL<br>HYDRAULIC, V. TYPE<br>HYDRAULIC, CONICAL FIRE RESISTING FLUIDS<br>HYDRAULIC, V. TYPE, FIRE RESISTING FLUIDS<br>FLAX OR HEMP<br>PLASTIC (FOR DOGS FOR WATERTIGHT CLOSURES)<br>METALLIC, FLEXIBLE<br>PLASTIC, METALLIC COIL FORM, BRAIDED METAL JACKET<br>PLASTIC, METALLIC COIL FORM, ± COTTON JACKET<br>PLASTIC, METALLIC COIL FORM, METAL FOIL JACKET<br>PREFORMED METALLIC AND NON-METALLIC RINGS<br>PREFORMED METALLIC AND NON-METALLIC RINGS<br>PLASTIC, METALLIC, COIL FORM ± COTTON JACKET (GAS SVCE)<br>CARBON, PREFORMED AND STOCK<br>ASBESTOS, BRAIDED, IMPREGNATED TFE, SURFACE LUBRICATED<br>ASBESTOS, IMPREGNATED<br>BRAIDED TFE (POLYTETRAFLUOROETHYLENE)<br>GRAPHITIC CORRUGATED RIBBON AND PREFORMED RING (v)<br>GRAPHITIC BRAIDED YARN (v)  | 1103<br>1104<br>1108<br>1109<br>1111<br>1112<br>1210<br>1220<br>1230<br>1240<br>1260<br>1425<br>1430<br>1432<br>1433<br>1434<br>1435<br>1436<br>1700 | HH P 34<br>HH P 34<br>MIL P 17303<br>MIL P 17303<br>MIL P 17303<br>MIL P 17303<br>MIL P 2911<br>MIL P 21099<br>MIL P 21099<br>HH P 106<br>MIL P 17378<br>MIL P 17416<br>MIL P 17303<br>MIL P 17303<br>MIL P 17303<br>MIL P 2863 GRADE A<br>MIL P 17303<br>MIL P 24377<br>MIL P 24058<br>MIL P 24396<br>MIL P 24503<br>DOD P 24583  |
| FIXED             | ASBESTOS SHEET, COMPRESSED<br>ASBESTOS METALLIC CLOTH AND TAPE<br>ASBESTOS METALLIC CLOTH<br>PAPER, FIBER (ANIMAL OR PLANT), SHEET<br>WOOL FELT, IMPREGNATED, ADHESIVE, PRESSURE SENSITIVE<br>RUBBER, SYNTHETIC, SHEET AND STRIP<br>RUBBER, SHEET, CLOTH INSERT<br>RUBBER GASKET MATERIAL (45 DUROMETER HARDNESS)<br>RUBBER GASKET MATERIAL (50 DUROMETER HARDNESS)<br>RUBBER, METAL INSERT, MOLDED (FOR ARMORED HATCHES)<br>RUBBER, SYNTHETIC, SHEET, STRIP, EXTRUDED, AND MOLDED<br>RUBBER CORE, ASBESTOS METALLIC COVER<br>RUBBER AND CORK COMPOSITION<br>RUBBER FOR POLAR FLUIDS, STEAM, OR AIR<br>RUBBER PETROLEUM AND PHOSPHATE ESTER FLUID RESISTANT<br>RUBBER, FLUOROCARBON, ELASTOMER<br>RUBBER SILICONE<br>GASKETS, METALLIC, ASBESTOS, SPIRAL WOUND (D)<br>GASKETS, METALLIC, ASBESTOS, SPIRAL WOUND (ANSI RIBS FLANGE)<br>GASKETS, METALLIC, ASBESTOS, SPIRAL WOUND (NAVY FLANGE)<br>LEAD SHEET<br>PLASTIC, LAMINATE, THERMOSETTING<br>PHENOLIC, PLUGS, CONDENSER AND HEAT EXCHANGER TUBES<br>THREAD COMPOUND, ANTI SEIZE, ZINC DUST PETROLATUM (W)<br>SEALING COMPOUND, JOINT AND THREAD, HIGH TEMPERATURE (V)<br>TAPE INSULATION, PLASTIC, PRESSURE SENSITIVE<br>SEALING COMPOUND<br>SEALING COMPOUND, METAL SEAM AND WOOD SEAM<br>SEALING COMPOUND, SYNTHETIC RUBBER BASE, WOOD SEAM<br>SEALING COMPOUND, DECK, POLYURETHANE<br>CASKEET MATERIAL, NON METALLIC | 2150<br>2151<br>2152<br>2290<br>2291<br>2351<br>2353<br>2355<br>2356<br>2360<br>2362<br>2363<br>2410<br>2473   | HH P 46<br>HH P 31<br>HH G 76<br>HH P 96<br>MIL G 20241<br>MIL G 1149<br>HH P 151<br>MIL R 900<br>MIL R 15624<br>MIL G 20078<br>MIL R 2765<br>MIL C 6183<br>MIL G 22050<br>MIL G 23652<br>MIL R 83248<br>ZZ R 765<br>MIL G 15342<br>MIL G 21032<br>MIL G 16265<br>QQ L 201<br>MIL P 15035<br>MIL P 15742<br>MIL T 22361<br>MIL S 15204<br>MIL I 24391<br>MIL S 8902<br>TT C 1796<br>MIL C 18255<br>MIL S 24340<br>ASTM F 104 NO. P 1151A |

| REVISIONS |    |                     |        |      |
|-----------|----|---------------------|--------|------|
| ZONE      | TR | DESCRIPTION         | DATE   | APVD |
| 9         |    | REVISED AND REDRAWN | 043080 |      |

**GENERAL NOTES**

- WHERE MORE THAN ONE SYMBOL OR SPECIFICATION IS REFERENCED FOR A SERVICE, THEY ARE CONSIDERED TO BE ALTERNATIVES, WITHIN THE CONDITIONS OR RESTRICTIONS SPECIFIED, AND ARE NOT NECESSARILY LISTED IN ORDER OF PREFERENCE
- LETTERS IN PARENTHESES REFER TO SUPPLEMENTARY NOTES BELOW
- PRESSURES AND TEMPERATURES ARE GIVEN IN POUND-FORCE PER SQUARE INCH GAGE (PSIG) AND DEGREES FAHRENHEIT (F), FOLLOWED BY THE CORRESPONDING S.I. UNITS, MEGAPASCALS (MPa) AND DEGREES CELSIUS (C) IN PARENTHESES
- O RING SEALS ARE NOT CONSIDERED HEREIN; CONSULT APPLICABLE SECTIONS OF THE NAVAL SHIPS TECHNICAL MANUAL (NAVSEA S9086-CM-STM-000 Ch 078; GASKETS, PACKINGS AND SEALS), MIL STD. 438, OR MIL STD. 777
- THIS DRAWING IS A COMPILATION OF INFORMATION FROM THE FOLLOWING SOURCES: MIL STD. 438, MIL STD. 777, N.S.T.M. AND VARIOUS EQUIPMENT SPECIFICATIONS. IT IS INTENDED FOR GUIDANCE IN REPAIR AND MAINTENANCE OF EXISTING EQUIPMENTS AND NOT FOR NEW DESIGN PURPOSES, IN THE EVENT OF CONFLICT, THE SOURCES TAKE PRECEDENCE.
- FOR HYDRAULIC SYSTEMS SEE NAVSEA S9086-54-STM-000 Ch 556

**SUPPLEMENTARY NOTES**

- A FOR RODS IN GOOD CONDITION ONLY.
- B 1430-1433 AND OTHER PUMP PACKINGS CONTAINING LEAD SHALL NOT BE USED IN NUCLEAR POWERED SHIPS.
- C EXCEPT FOR BRASS, BRONZE OR PLAIN MONEL RODS AND SHAFT SLEEVES
- D FOR BOILER MANHOLES AND HANDHOLES ONLY
- E, EXCEPTING POTABLE.
- F 1433 WITH END RINGS OF 1430 OR 1103.
- G FOR BOTTOM BLOW VALVE SLEEVE USE 2150 1/8 THICK.
- H USE 1435 GRADE B FOR AIR EJECTORS INTERCONDENSER
- I FOR REPLACEMENT PURPOSES ONLY WITH BRONZE FLANGES.
- J FOR CONDENSATE ONLY
- K SURFACE VESSELS ONLY
- L USE ONLY IF PACKING SPECIFIED BY MANUFACTURER IS NOT AVAILABLE
- M FOR APPLICATION ABOVE 700F USE BRAIDED COPPER OR COPPER FLOSS
- N SEE DETAILS ON STD. DWGS 810-1385866 AND 810-1385899.
- P MAX 50 PSIG AND ROD SPEED OF 1375 FPM
- Q SUITABLE FOR PISTON USAGE
- R CONSULT TECHNICAL MANUAL OR NAVAL SHIPS TECHNICAL MANUAL (NSTM) FOR SPECIFIC SYSTEM COMPONENTS USED
- S USE PRIMER FOR WOOD OR METAL AS RECOMMENDED FOR SPECIFIC PRODUCT USED
- T FOR LOW CHLORIDE APPLICATIONS
- U SURFACE TREATMENT BEFORE ATTACHMENT:  
1. WOOD; 1 COAT PHENOLIC VARNISH TT V 119  
2. METAL; 2 COATS EPOXY POLYAMIDE PRIMER (FORMULA 150) MIL P 24441  
WHERE ALUMINUM IS ATTACHED TO A DISSIMILAR MATERIAL THEY MUST BE SEPARATED BY A MINIMUM OF 0.020 INCHES OF TAPE MIL I 24391 TO EXTEND 1/4" BEYOND EDGE OF JOINT
- V D.O.D. P. 24583 (ANTI EXTRUSION RINGS) MUST BE USED WITH MIL P 24503 (GRAPHITIC CORRUGATED RIBBON)
- W FOR AMBIENT TEMPERATURES THREADED JOINTS SHALL USE MIL T 22361  
ELEVATED TEMPERATURES UP TO 400F USE 50 PERCENT, BY WEIGHT, ZINC DUST AND SILICON GREASE MIL S 8660  
POWER PLANT APPLICATIONS (1200 PSIG AND 950F) USE MIL S 15204 TYPE A, OR B
- X. TADPOLE GASKETS OR MIL S 15204 TYPE C SEE DWG NO 5000-55102-C-841624.
- Y AND AS APPROVED BY NAVAL SEA SYSTEMS COMMAND
- Z SEE N.S.T.M. (NAVSEA S9086-CM-STM-000 Ch 078, GASKETS, PACKINGS, AND SEALS) AND 0901-LP-450-0002 Ch 9450
- AA MAXIMUM OF 80 PSIG
- BB 300F FOR SYNTHETIC OIL, MIL L 23699, USED IN GAS TURBINES

| FITNESS                              |   |   |  |   |  |
|--------------------------------------|---|---|--|---|--|
| GASKETS, BALLISTIC DOORS AND HATCHES | GASKETS, DOORS, HATCHES, DOGGED MANHOLES, SCUTTLES, AIRPORTS, AND VENTILATION ACCESS PLATES | GASKETS, HATCHES, SCUTTLES, AND DOORS IN MISSILE BLAST AREA | GASKETS, BETWEEN AIRPORT SHELL FRAME AND SHELL (EXCEPTING ITEMS 24 AND 25) | GASKETS, BOLTED PLATES AND MANHOLES (EXCEPTING ITEM 36) | GASKETS, BOLTED PLATES AND MANHOLES TO FRESH WATER TANKS |
| 31                                   | 32  | 33  | 34   | 35  | 36   |
| 2360                                 | 2356<br>ZZ R 765  | 22 R 765  | TT C 1796  | MIL S 1802<br>2290 TYPE II<br>MIL C 6183<br>CLASS I     | 2351 CLASS 2<br>2353<br>(1/8 THICK)                      |

| FIXED JOINTS - AIR AND FLAME TIGHTNESS                     |  |                                  |    |
|--|--|----------------------------------|----|
| GASKETS, FLAME TIGHT JOINER DOORS                          | GASKETS, AIRTIGHT DOORS, HATCHES, SCUTTLES, DOGGED MANHOLES, AIRPORTS, AND VENTILATION ACCESS PLATES | FLANGES, VENTILATION DUCT HEATER |    |
| 49   | 50   | 51                               | 52 |
| 2355<br>ZZ R 765<br>(CLASS 25<br>IN FIRE ZONE<br>BULKHEAD) | 2355   | 2150 CLASS I<br>2291             |    |

| STRUCTURAL FIXED JOINTS - NON TIGHT |                      |                                   |
|-------------------------------------|----------------------|-----------------------------------|
| ALUMINUM FAY SURFACES               | ALUMINUM TO ALUMINUM | ALUMINUM TO OTHER METALS AND WOOD |
| 53                                  | 54                   | 55                                |
| NOTE U                              | NOTE U               |                                   |

**WARNING**

EXPOSURE TO ASBESTOS FIBERS IS A RECOGNIZED HEALTH HAZARD. REFER TO N.S.T.M. CHAPTER 635 FOR SAFETY REQUIREMENTS APPLICABLE TO HANDLING ASBESTOS PACKINGS AND GASKETS.

SUPERSEDES DWG. B-153 (REV. 8) 7 JULY 1951

STANDARD DRAWING

DEPARTMENT OF THE NAVY  
NAVAL SHIP SYSTEMS COMMAND  
WASHINGTON, D.C. 20350

PACKINGS AND GASKETS  
APPLICATION CRITERIA FOR

|               |      |       |             |      |
|---------------|------|-------|-------------|------|
| PREPARED      | DATE | SCALE | DRAWING NO. | REV. |
| CHECKED       |      |       | B-153       | 9    |
| NO. ENGR.     |      |       | 80064       |      |
| NAVY APPROVAL |      |       |             |      |
| PROJ. ENGR.   |      |       |             |      |
| SECT. NO.     |      |       |             |      |
| DW. NO.       |      |       |             |      |
| REV. NO.      |      |       |             |      |

GS3V1F0647B

Figure 6-47.—Application criteria for packings and gaskets—Continued.





## CHAPTER 7

# ENGINEERING SUPPORT AND AUXILIARY EQUIPMENT

Gas turbine propulsion plants are dependent on reliable auxiliary systems. The proper maintenance and operation of auxiliary systems will enhance the performance of main propulsion machinery. As a GSE or GSM, you must have a thorough knowledge of main propulsion auxiliary machinery and systems. In this chapter we will describe some of the maintenance, operating problems, and repair of pumps, purifiers, air compressors, dehydrators, waste-heat boilers, and oily-water separators.

Before any maintenance or repair work is started, you should consult the MRCs and the manufacturers' technical manuals. These materials contain information concerning specifications, clearances, procedural steps, and troubleshooting techniques of engine-room auxiliary machinery.

Proper maintenance or repair work consists of problem diagnosis, disassembly, measurements, corrections of problems, and reassembly. Use of proper tools, knowledge of the construction of equipment, proper work-site management, and cleanliness are keys to successful maintenance and repair work.

Good housekeeping is an integral part of preventive maintenance. Nothing adds more to the impression of a well-maintained plant than cleanliness. Team work is required on the part of all hands to maintain a clean plant. Maintenance personnel must realize that the repair job is NOT complete until the old and surplus material has been removed. It is difficult for operators to remain concerned about cleanliness when improperly designed or maintained equipment continually allows oil or water to leak. If a piece of equipment is designed to leak a fluid, be sure the leakoff remains within specifications.

Work-site cleanliness is as important as space cleanliness. Dirt and foreign matter

are s harmful to machinery as improper lubrication.

Early replacement and/or failure results from inadequate attention to detail during maintenance procedures. Improper materials, wrong clearances, misalignments, or inattention to torque specifications are but a few of the commonly overlooked maintenance requirements. Memory should not be relied upon to determine when an inspection should be made, bearings lubricated, or equipment rotated. Sooner or later something will be neglected and failure will result, posing a safety problem for personnel and equipment.

With the knowledge gained in this chapter, you should be able to describe pumps, purifiers, air compressors, dehydrators, waste-heat boilers, and oily-water separators in terms of their construction, function, and operation. The material presented in this chapter is representative in nature. By studying this material, you should be able to relate to the specific equipment found on your ship.

### PUMPS

Pumps are vitally important to the operation of your ship. If they fail, the power plant they serve also fails. In an emergency, pump failures can prove disastrous. Therefore, maintaining pumps in an efficient working order is a very important task of the Gas Turbine Systems Technician.

It is not practical or necessary to mention all of the various locations where pumps are found aboard ship. You will learn their location and operation as you perform your duties as a GSE or a GSM. Pumps with

which you are primarily concerned are used for such purposes as

- providing fuel oil to the GTE,
- circulating lubricating (lube) oil to the bearings and gears of the MRG,
- supplying seawater for the coolers in engineering spaces,
- pumping out the bilges, and
- transferring fuel oil to various storage and service tanks.

## CLASSIFICATION OF PUMPS

Pumps aboard ship outnumber all other auxiliary machinery units. They include such types as centrifugal, rotary, and jet pumps. In the following section we discuss these different pumps and their application to the engineering plant.

### Centrifugal Pumps

Aboard gas turbine ships, centrifugal pumps of various sizes are driven by electric motors to move different types of liquid. The fire pump and seawater service pump are two examples of this type of pump.

A basic centrifugal pump has an impeller keyed to a drive shaft, which is rotated by an electric motor. The drive shaft is fitted inside a casing which has a suction inlet and a discharge outlet. Figure 7-1 shows the arrangement of components in a centrifugal pump.

**CENTRIFUGAL PUMP CLASSIFICATION.**—Centrifugal pumps may be classified in several ways. For example, they may be either single-stage or multistage. A single-stage pump has only one impeller; a multistage pump has two or more impellers housed together in one casing. In a multistage pump, each impeller usually acts separately, discharging to the suction of the next-stage impeller. Centrifugal pumps are also classified as horizontal or vertical, depending on the position of the pump shaft.

Impellers used in centrifugal pumps may be classified as single-suction or double-suction, depending on the way in which liquid enters the eye of the impeller. Figure 7-2 shows single-suction and double-suction arrangements of centrifugal pump impellers. The single-suction impeller (view A) allows liquid to enter the eye from one side only; the double-suction impeller (view B) allows liquid to enter the eye from both sides. The double-suction arrangement has the advantage of balancing the end thrust in one direction with the end thrust in the other direction.

Impellers are also classified as CLOSED or OPEN. A closed impeller has side walls that extend from the eye to the outer edge of the vane tips; an open impeller does not have side walls. Most centrifugal pumps used in the Navy have closed impellers.

**CONSTRUCTION.**—As a rule, the casing for the liquid end of a pump with a single-suction impeller is made with an end plate that can be removed for inspection and repair of the pump. A pump with a double-suction impeller is generally made so one-half of the casing may be lifted without disturbing the pump.

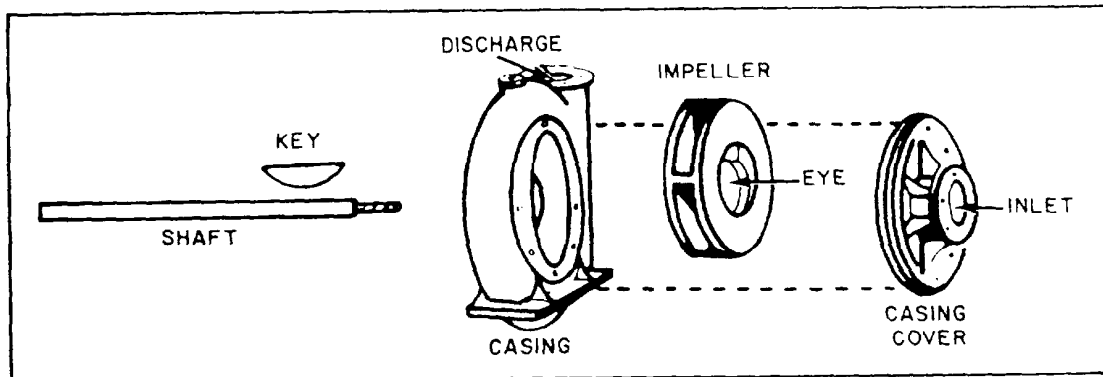

Figure 7-1.—Centrifugal pump

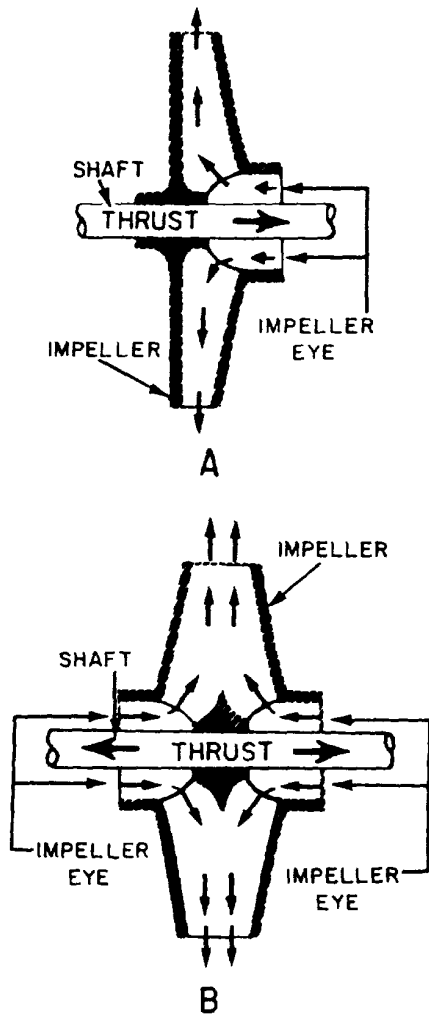

Figure 7-2.—Centrifugal pump impellers. A. Single-suction. B. Double-suction.

Since an impeller rotates at high speed, it must be carefully machined to minimize friction. An impeller must be balanced to avoid vibration. A close radial clearance must be maintained between the outer hub of the impeller and that part of the pump casing in which the hub rotates. The purpose of this is to minimize leakage from the discharge side of the pump casing to the suction side.

Because of the high rotational speed of the impeller and the necessarily close clearance, the rubbing surfaces of both the impeller hub and the casing at that point are subject to stress, causing rapid wear. To eliminate the need for replacing an entire impeller and pump casing solely because of wear in this location, most centrifugal pumps are designed with replaceable casing wearing rings.

In most centrifugal pumps, the shaft is fitted with a replaceable sleeve. The advantage of using a sleeve is that it can be replaced more economically than the entire shaft.

Mechanical seals and stuffing boxes are used to seal between the shaft and the casing. Most pumps are now furnished with mechanical seals; mechanical seals do not result in better pump operation but do provide a better environment, dry bilges, and preservation of the liquid being pumped.

Seal piping (liquid seal) is installed to cool the mechanical seal. Most pumps in saltwater service with total head of 30 psi or more are also fitted with cyclone separators. These separators use centrifugal force to prevent abrasive material (such as sand in the seawater) from passing between the sealing surfaces of the mechanical seal. There is an opening at each end of the separator. The opening at the top is for “clean” water, which is directed through tubing to the mechanical seals in the pump. The high-velocity “dirty” water is directed through the bottom of the separator, back to the inlet piping for the pump.

Bearings support the weight of the impeller and shaft and maintain the position of the impeller—both radially and axially. Some bearings are grease-lubricated with grease cups to allow for periodic relubrication.

The power end of the centrifugal pump has an electric motor that is maintained by you or the ship’s Electrician’s Mate.

**OPERATION.**—Liquid enters the rotating impeller on the suction side of the casing and enters the eye of the impeller (fig. 7-3). Liquid

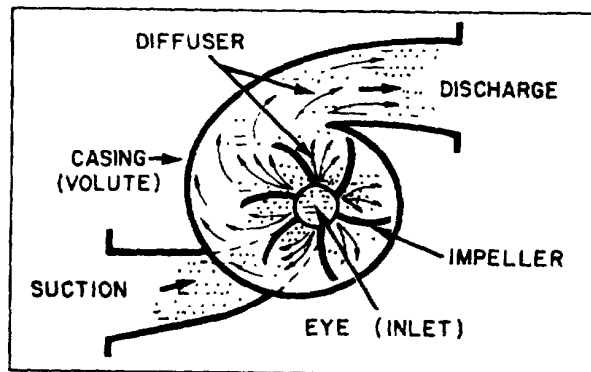

Figure 7-3.—Centrifugal pump flow.

is thrown out through the opening around the edge of the impeller and against the side of the casing by centrifugal force. Centrifugal force is force that is exerted upon a body or substance by rotation. Centrifugal force impels the body or substance outward from the axis of rotation. When liquid is thrown out to the edge of the casing, a region of low pressure (below atmospheric) is created around the center of the impeller; more liquid moves into the eye to replace the liquid that was thrown out. Liquid moves into the center of the impeller with a high velocity (speed). Therefore, liquid in the center of the impeller has a low pressure, but it is moving at a high velocity.

Liquid moving between the blades of the impeller spreads out, which causes the liquid to slow down. (Its velocity decreases.) At the same time, as the liquid moves closer to the edge of the casing, the pressure of the liquid increases. This change (from low pressure and high velocity at the center to high pressure and low velocity at the edge) is caused by the shape of the opening between the impeller blades. This space has the shape of a diffuser, a device that causes the velocity-pressure relationship of any fluid that moves through it to change.

A centrifugal pump is considered to be a nonpositive-displacement pump because the volume of liquid discharged from the pump changes whenever the pressure head changes. The pressure head is the combined effect of liquid weight, fluid friction, and obstruction to flow. In a centrifugal pump, the force of the discharge pressure of the pump must be able to overcome the force of the pressure head; otherwise, the pump could not deliver any liquid to a piping system. The pressure head and the discharge pressure of a centrifugal pump oppose each other. When the pressure head increases, the discharge pressure of the pump must also increase. Since no energy can be lost, when the discharge pressure of the pump increases, the velocity of flow must decrease. On the other hand, when the pressure head decreases, the volume of liquid discharged from the pump increases. As a general rule, a centrifugal pump is usually located below the liquid being pumped. (**NOTE:** This discussion assumes a constant impeller speed.)

Figure 7-4 shows that when the pump discharge is blocked, nothing happens because the impeller is hollow. A tremendous buildup in

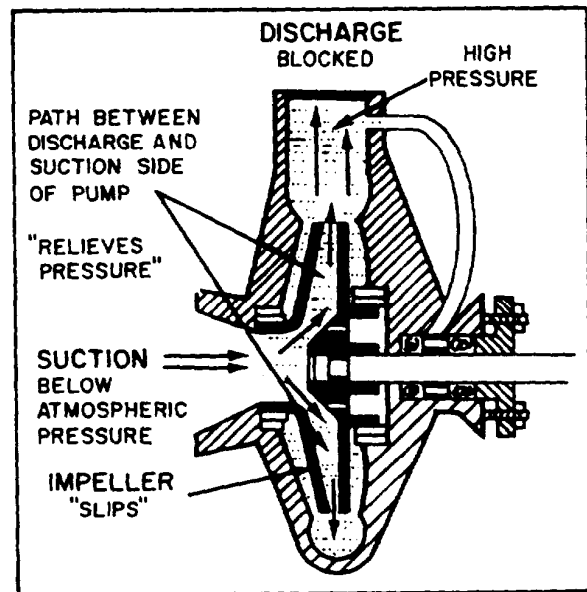

Figure 7-4.—Nonpositive-displacement pump.

pressure cannot occur because the passages in the impeller (between the discharge and suction side of the pump) act like a built-in relief valve. When the discharge pressure and pressure head are equal (as in this case), the impeller is allowed to rotate (slips) through the liquid in the casing.

**NOTE:** Centrifugal pumps used for intermittent service may have to run for long periods of time against a blocked discharge. Friction between the impeller and the liquid raises the temperature of the liquid in the casing and causes the pump to overheat. To prevent this, a small line is connected between the discharge and the suction piping of the pump.

When a centrifugal pump is started, the vent line must be opened to release entrained air. The open passage through the impeller of a centrifugal pump also causes another problem. It is possible for liquid to flow backwards (reverse flow) through the pump. A reverse flow, from the discharge back to the suction, can happen when the pressure head overcomes the discharge pressure of the pump. A reverse flow can also occur when the pump is not running and another pump is delivering liquid to the same piping system. To prevent a reverse flow of liquid through a centrifugal pump, a check valve is usually installed in the discharge line.

**NOTE:** Instead of two separate valves, some installations use a globe stop-check valve.

With a check valve in the discharge line, whenever the pressure above the disk rises above the pressure below it, the check valve shuts. This prevents liquid from flowing backwards through the pump.

**MAINTENANCE.**—You must observe the operation and safety precautions pertaining to pumps by following the EOP subsystem of the EOSS—if your ship has EOSS. If not, use *Naval Ships' Technical Manual* and/or the instructions posted on or near each individual pump. You must follow the manufacturer's technical manual or MRCs for PMS-related work for all maintenance work. The MRCs list in detail what you have to do for each individual maintenance requirement.

**Mechanical Seals.**—Mechanical seals are rapidly replacing conventional packing as the means of controlling leakage on centrifugal pumps. Pumps fitted with mechanical seals eliminate the problem of excessive stuffing box leakage, which can result in pump and motor bearing failures and motor winding failures.

Where mechanical shaft seals are used, the design ensures that positive liquid pressure is supplied to the seal faces under all conditions of operation and that there is adequate circulation of the liquid at the seal faces to minimize the deposit of foreign matter on the seal parts.

One type of a mechanical seal is shown in figure 7-5. Spring pressure keeps the rotating seal face snug against the stationary seal face. The rotating seal and all of the assembly below it are affixed to the pump shaft. The stationary seal face is held stationary by the seal gland and packing ring. A static seal is formed between the two seal faces and the sleeve. System pressure within the pump assists the spring in keeping the rotating seal face tight against the stationary seal face. The type of material used for the seal face depends on the service of the pump. When a seal wears out, it is simply replaced.

You should observe the following precautions when performing maintenance on mechanical seals:

- Do not touch new seals on the sealing face because body acid and grease can cause the seal face to prematurely pit and fail.

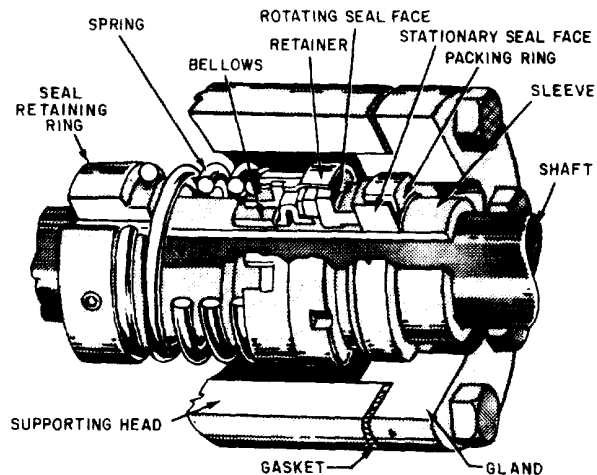

Figure 7-5.—Type-1 mechanical seal.

- Replace mechanical seals when the seal is removed for any reason or when the leakage rate cannot be tolerated.
- Position mechanical shaft seals on the shaft by stub or step sleeves. Shaft sleeves are chamfered (beveled) on outboard ends to provide ease of mechanical seal mounting.
- Do not position mechanical shaft seals by using setscrews.

Fire pumps and all seawater pumps installed in surface ships are being provided with mechanical shaft seals with cyclone separators. The glands are designed to incorporate two or more rings of packing if the mechanical shaft seal fails.

A water flinger is fitted on the shaft outboard of the stuffing box glands to prevent leakage from the stuffing box following along the shaft and entering the bearing housings. They must fit tightly on the shaft. If the flingers are fitted on the shaft sleeves instead of on the shaft, ensure that no water leaks under the sleeves.

**Stuffing Box Packing.**—Although most centrifugal pumps on gas turbine ships have mechanical seals, you should be familiar with stuffing box packing.

The packing in centrifugal pump stuffing boxes (fig. 7-6) is renewed following the PMS. When replacing packing, be sure to use packing of the specified material and the correct size. Stagger the joints in the packing rings so they fall at different points around the shaft. Pack the stuffing box loosely and set up lightly on the gland, allowing a liberal leakage. With the pump in operation, tighten the glands and gradually compress the packing. It is important to do this gradually and evenly to avoid excessive friction. Uneven tightening could cause overheating and possible scoring of the shaft or the shaft sleeve.

On some centrifugal pumps, a lantern ring is inserted between the rings of the packing. When repacking stuffing boxes on such pumps, be sure to replace the packing beyond the lantern ring. The packing should not block off the liquid seal line connection to the lantern ring after the gland has been tightened.

Figure 7-6 shows how the packing is arranged. Notice how the lantern ring lines up with the liquid seal connection when the gland is tightened.

**Renewing Shaft Sleeves.**—In some pumps the shaft sleeve is pressed onto the shaft tightly by a hydraulic press. In this case, the old sleeve must be machined off with a lathe before a new one

can be installed. On others, the shaft sleeve may have a snug slip-on fit, butted up against a shoulder on the shaft and held securely in place with a nut. On smaller pumps, you can install new sleeves by removing the water end casing, impeller, and old shaft sleeves. New sleeves are carried as repair parts; they can also be made in the machine shop. On a large pump, the sleeve is usually pressed on; the old sleeve must be machined off before a new one can be pressed on. You must disassemble the pump and take the sleeve to a machine shop, a repair shop, or a naval shipyard to have this done.

To prevent water leakage between the shaft and the sleeve, some sleeves are packed, others have an O-ring between the shaft and the abutting shoulder. For detailed information, consult the appropriate manufacturer's technical manual or applicable blueprint.

**Renewing Wearing Rings.**—The clearance between the impeller and the casing wearing ring (fig. 7-7) must be maintained as directed by the manufacturer. When clearances exceed the specified amount, the casing wearing ring must be replaced. On most ships, this job can be done by the ship's force, but it requires the complete disassembly of the pump. All

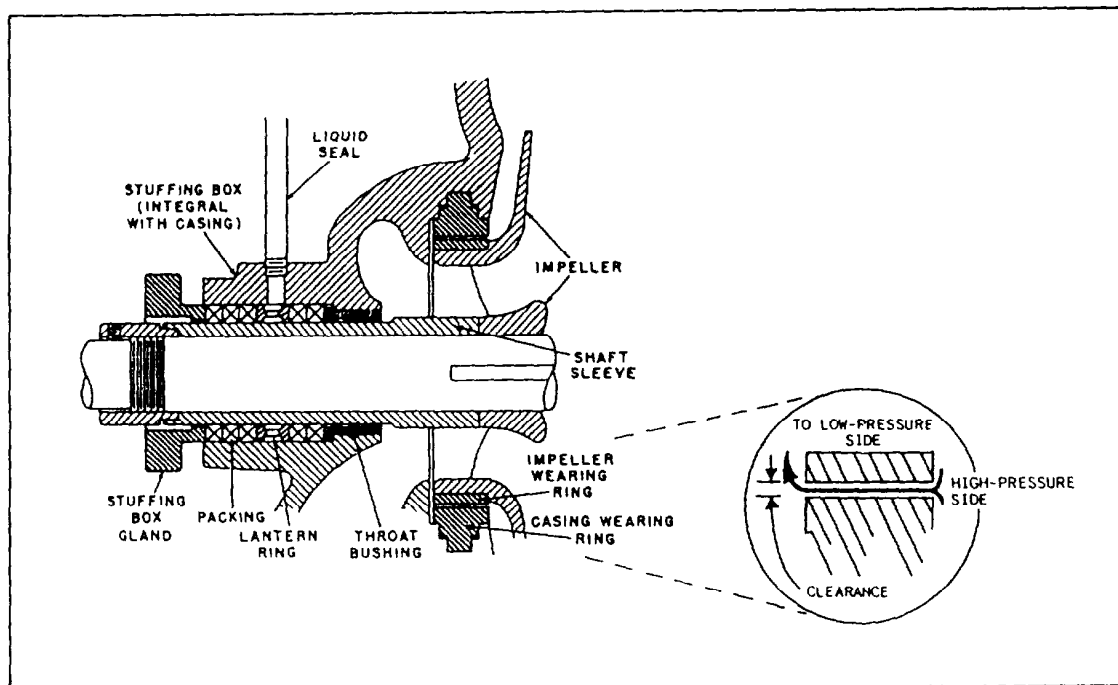

Figure 7-6.—Stuffing box on a centrifugal pump.

necessary information on disassembly of the unit, dimensions of the wearing rings, and reassembly of the pump is specified by PMS or can be found in the manufacturer's technical manual. Failure to replace the casing wearing ring when the allowable clearance is exceeded results in a decrease of pump capacity and efficiency. If you have to disassemble a pump because of some internal trouble, check the wearing ring for clearance. Measure the outside diameter of the impeller hub with an outside micrometer and the inside diameter of the casing wearing ring with an inside micrometer; the difference between the two diameters is the actual wearing ring diametric clearance. By checking the actual wearing ring clearance with the maximum allowable clearance, you can decide whether to renew the ring before reassembling the pump. The applicable MRCs are a readily available source of information on proper clearances.

Wearing rings for most small pumps are carried aboard ship as part of the ship's repair parts allowance. These may need only a slight amount of machining before they can be installed. For some pumps, spare rotors are carried aboard ship. The new rotor can be installed and the old rotor sent to a repair activity for overhaul. Overhauling a rotor includes renewing the wearing rings, bearings, and shaft sleeve.

**Operating Troubles.**—You will be responsible for the maintenance of centrifugal pumps. The

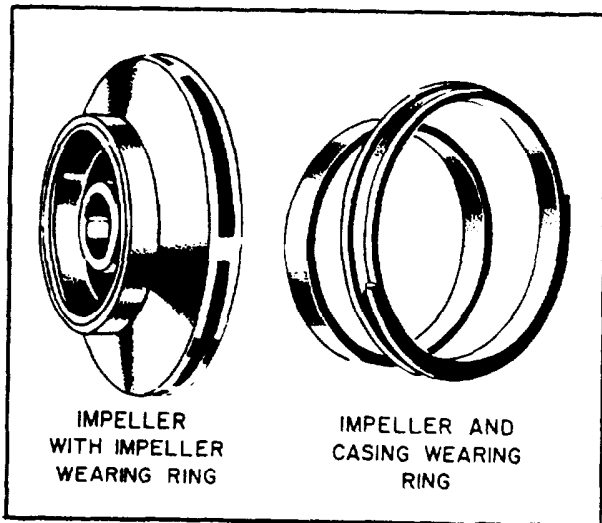

Figure 7-7.—Impeller, impeller wearing ring, and casing wearing ring for a centrifugal pump.

following table is a description of some of the problems you will have to deal with together with the probable causes:

| <u>TROUBLE</u>                                     | <u>CAUSE</u>  |
|--|---|
| Does not deliver any liquid                        | Insufficient priming  |
|  | Insufficient speed of the pump  |
|  | Excessive discharge pressure (such as a partially closed valve or some other obstruction in the discharge line) |
|  | Excessive suction lift  |
|  | Clogged impeller passages   |
|  | Wrong direction of rotation   |
|  | Clogged suction screen (if used)  |
|  | Ruptured suction line   |
|  | Loss of suction pressure  |
|  | Insufficient capacity   |
| Insufficient speed of the pump                     |   |
| Excessive suction lift                             |   |
| Clogged impeller passages                          |   |
| Excessive discharge pressure                       |   |
| Does not develop enough discharge pressure         | Mechanical defects (such as worn wearing rings, impellers, stuffing box packing, or sleeves)                    |
|  | Insufficient speed of the pump  |
|  | Air or gas in the liquid being pumped   |
|  | Mechanical defects (such as worn wearing rings, impellers, leaking mechanical seals, and sleeves)               |
| Works for a while and then fails to deliver liquid | Air leakage into the suction line   |
|  | Air leakage in the stuffing boxes   |
|  | Clogged water seal passages   |
|  | Insufficient liquid on the suction side   |
|  | Excessive heat in the liquid being pumped   |



| <u>TROUBLE</u>                               | <u>CAUSE</u>   |
|--|--|
| Takes too much power and the motor overheats | Operation of the pump at excess capacity and insufficient discharge pressure |
|  | Misalignment   |
|  | Bent shaft   |
|  | Excessively tight stuffing box packing                                       |
|  | Worn wearing rings   |
| Vibration                                    | Other mechanical defects   |
|  | Misalignment   |
|  | Bent shaft   |
|  | Clogged, eroded, or otherwise unbalanced impeller                            |
|  | Lack of rigidity in the foundation   |

Insufficient suction pressure may cause vibration, as well as noisy operation and fluctuating discharge pressure.

### Rotary Pumps

Another type of pump you find aboard ship is the rotary pump. A number of types are

included in this classification, among which are the gear pump, the screw pump, and the moving vane pump. Unlike the centrifugal pump, which we have discussed, the rotary pump is a positive-displacement pump. This means that for each revolution of the pump, a fixed volume of fluid is moved regardless of the resistance against which the pump is pushing. As you can see, any blockage in the system could quickly cause damage to the pump or a rupture of the system. You, as the pump operator, must always be sure the system is properly aligned so a complete flow path exists for fluid flow. Also, because of their positive displacement feature, rotary pumps require a relief valve to protect the pump and piping system. The relief valve lifts at a preset pressure and returns the system liquid either to the suction side of the pump or back to the supply tank or sump.

Rotary pumps also differ from centrifugal pumps in that they are essentially self-priming. As we saw in our discussion of centrifugal pumps, the pump is usually located below the liquid being pumped; gravity creates a static pressure head which keeps the pump primed. A rotary pump can operate within limits with the pump located above the liquid being pumped.

A good example of the principle that makes rotary pumps self-priming is the simple drinking

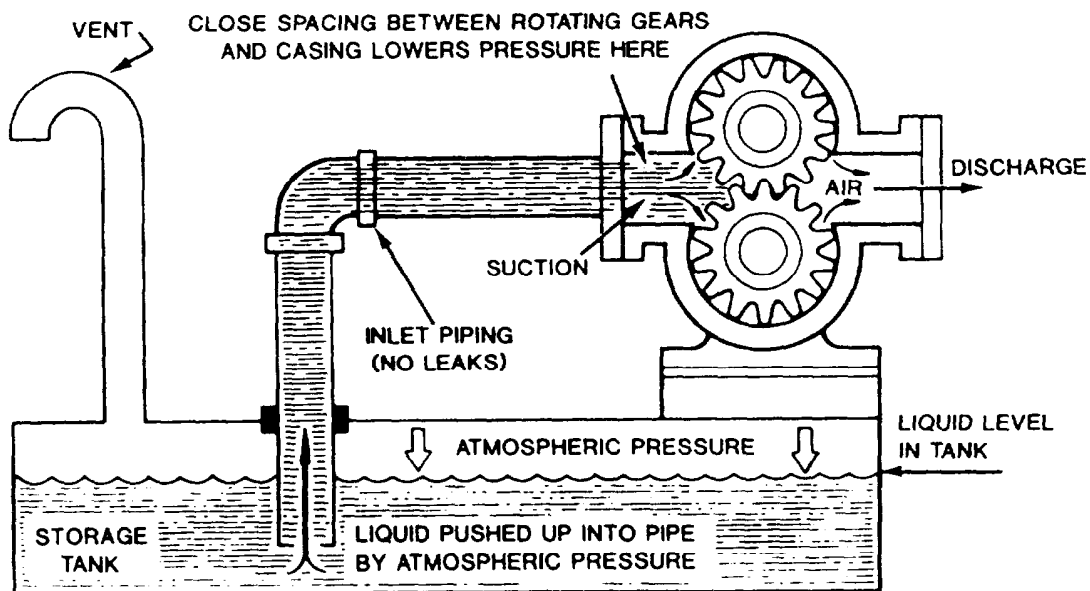

Figure 7-8.—Gear pump located above the tank.

straw. As you suck on the straw, you lower the air pressure inside the straw. Atmospheric pressure on the surface of the liquid surrounding the straw is therefore greater and forces the liquid up the straw. The same conditions basically exist for the gear and screw pump to prime itself. Figure 7-8 shows a gear pump located above the tank. The tank must be vented to allow air into the tank to provide atmospheric pressure on the surface of the liquid. To lower the pressure on the suction side of the pump, the clearances between the pump parts must be close enough to pump air. When the pump starts, the air is pumped through the discharge side of the pump and creates the low-pressure area on the suction side which allows the atmospheric pressure to force the liquid up the pipe to the pump. To operate properly, the piping leading to the pump must have no leaks or it will draw in air and can lose its prime.

Rotary pumps are useful for pumping oil and other heavy viscous liquids. In the engine room, rotary pumps are used for handling lube oil and fuel oil and are suitable for handling liquids over a wide range of viscosities.

Rotary pumps are designed with very small clearances between rotating parts and stationary parts to minimize leakage (slippage) from the discharge side back to the suction side. Rotary pumps are designed to operate at relatively slow speeds to maintain these clearances; operation at higher speeds causes erosion and excessive wear, which result in increased clearances with a subsequent decrease in pumping capacity.

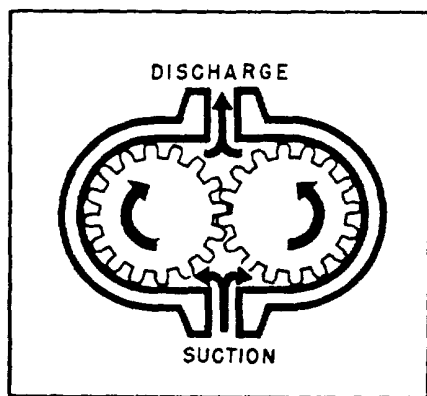

Figure 7-9.—Simple gear pump.

Classification of rotary pumps is generally based on the types of rotating element. In the following paragraphs, the main features of some common types of rotary pumps are described.

**GEAR PUMPS.**—The simple gear pump (fig. 7-9) has two spur gears that mesh together and revolve in opposite directions. One is the driving gear, and the other is the driven gear. Clearances between the gear teeth (outside diameter of gear) and the casing and between the end face and the casing are only a few thousandths of an inch. As the gears turn, the gears unmesh and liquid flows into the pockets that are vacated by the meshing gear teeth. This creates the suction that draws the liquid into the pump. The liquid is then carried along in the pockets formed by the gear teeth and the casing. On the discharge side, the liquid is displaced by the meshing of the gears and forced out through the discharge side of the pump.

One example of the use of a gear pump is in the LM2500 engine fuel pump. However, gear pumps are not used extensively on gas turbine ships.

**SCREW PUMPS.**—Several different types of screw pumps exist. The differences between the various types are the number of intermeshing screws and the pitch of the screws. Figure 7-10 shows a double-screw, low-pitch pump.

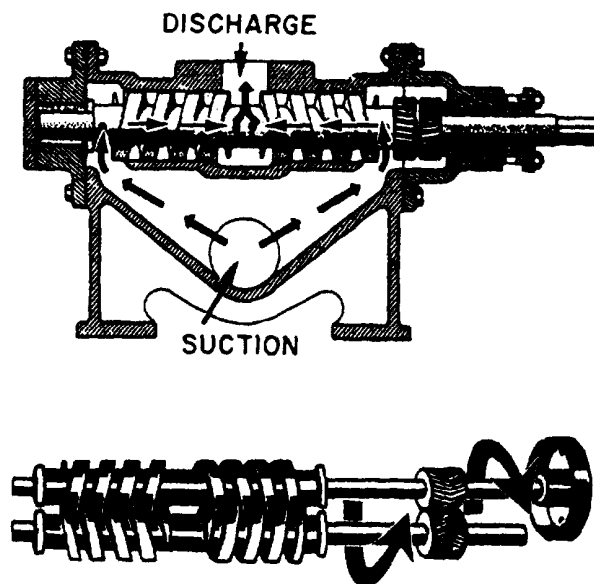

Figure 7-10.—Double-screw, low-pitch pump.

pump; and figure 7-11 shows a triple-screw, high-pitch pump. Screw pumps are used aboard ship to pump fuel and lube oil and to supply pressure to the hydraulic system. In the double-screw pump, one rotor is driven by the drive shaft and the other by a set of timing gears. In the triple-screw pump, a central rotor meshes with two idler rotors.

In the screw pump, liquid is trapped and forced through the pump by the action of rotating screws. As the rotor turns, the liquid flows in between the threads at the outer end of each pair of screws. The threads carry the liquid along within the housing to the center of the pump, where it is discharged.

Most screw pumps are now equipped with mechanical seals. If the mechanical seal fails, the stuffing box has the capability of accepting two rings of conventional packing for emergency use.

**SLIDING VANE PUMPS.**—The sliding-vane pump (fig. 7-12) has a cylindrically bored housing with a suction inlet on one side and a discharge outlet on the other side. A rotor (smaller in diameter than the cylinder) is driven about an axis that is so placed above the center line of the cylinder as to provide minimum clearance between the rotor and cylinder at the top and maximum clearance at the bottom.

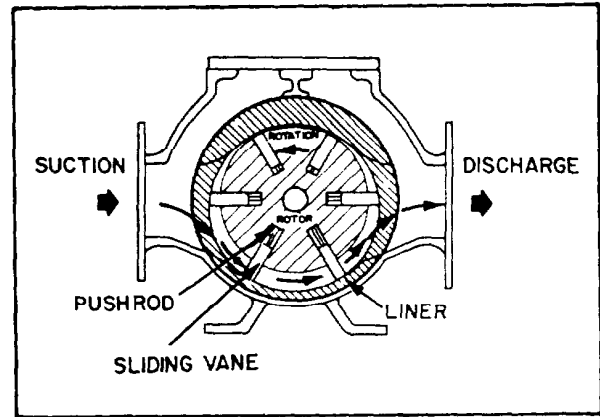

Figure 7-12.—Sliding vane pump.

The rotor carries vanes (which move in and out as the rotor rotates) to maintain sealed spaces between the rotor and the cylinder wall. The vanes trap liquid on the suction side and carry it to the discharge side, where contraction of the space expels liquid through the discharge line. The vanes slide on slots in the rotor. Vane pumps are used for lube oil service and transfer, tank stripping, bilge, aircraft fueling and defueling, and, in general, for handling lighter viscous liquids.

### Jet Pumps

The pumps discussed so far in this chapter have had a variety of moving parts. One type of pump you find in the engine room is the jet pump, usually called an eductor. Figure 7-13 shows an eductor, which has no moving parts. These pumps are used for pumping large quantities of water overboard in such applications as pumping bilges and dewatering compartments. Eductors are also being used on distilling plants as air or brine eductors.

Eductors use a high-velocity jet of seawater to lower the pressure in the chamber around the converging nozzle. Seawater is supplied to the converging nozzle at a relatively low velocity and exits the nozzle at a high velocity. As the seawater leaves the nozzle and passes through the chamber, air becomes entrained in the jet stream and is pumped out of the chamber. Pressure in the chamber decreases, allowing atmospheric pressure to push the surrounding water into the chamber and mix with the jet stream. The diverging nozzle allows the velocity of the fluid to decrease and the pressure to increase; the discharge pressure is then established.

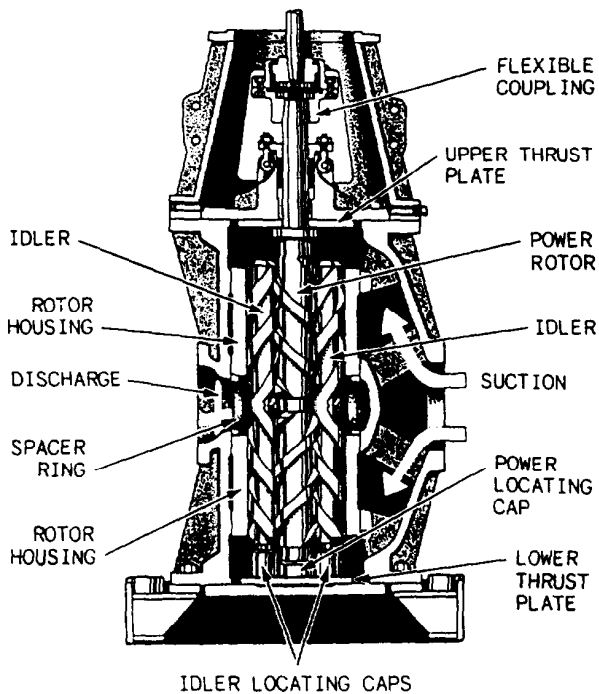

Figure 7-11.—Triple-screw, high-pitch pump.

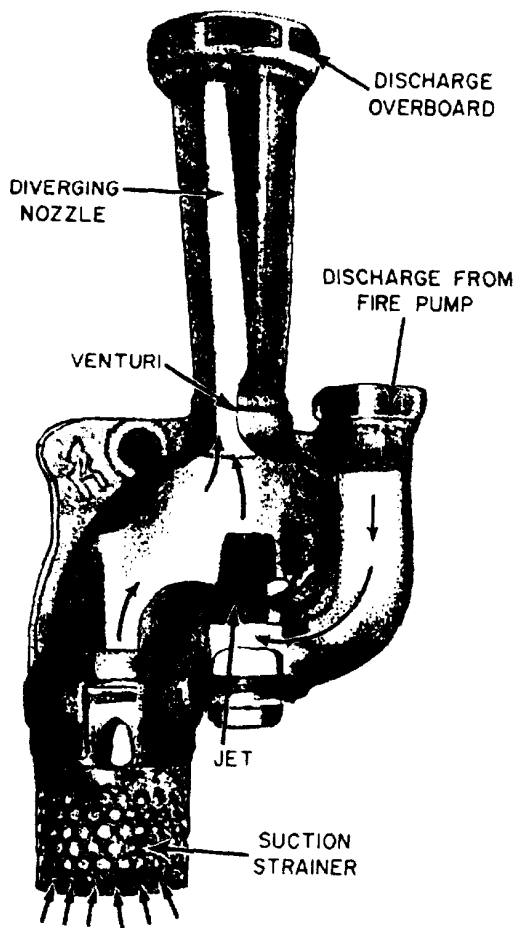

Figure 7-13.—Eductor.

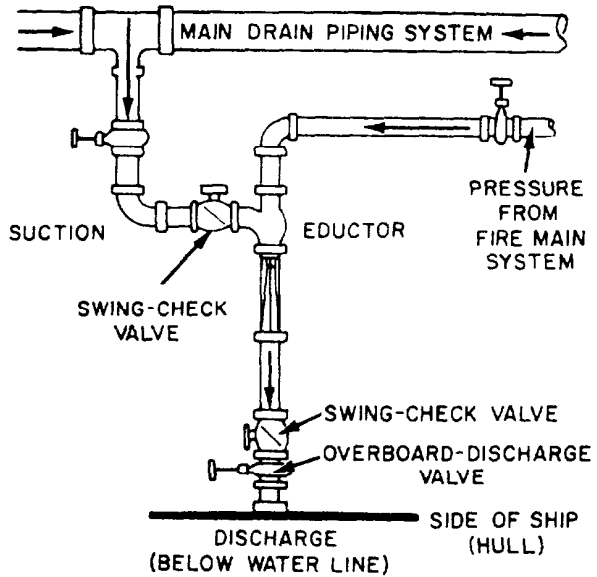

Figure 7-14.—Typical eductor system.

and throat bushings. Always check the shaft alignment with all the piping in place.

Some driving units are connected to the pump by a FLEXIBLE COUPLING. A flexible coupling (fig. 7-15) is intended to take care of only a slight misalignment. Misalignment should never exceed the amount specified by the pump

Figure 7-14 is an example of a typical shipboard eductor system. Note that the eductor discharge piping is below the water line. The swing-check valve above the overboard-discharge valve prevents water from backing up into the system if the system pressure drops below the outside water pressure. To prevent engineering spaces from flooding, you must follow the step-by-step procedures that are posted next to eductor stations.

### ALIGNMENT OF SHAFT AND COUPLING

When you install or assemble pumps driven by electric motors, ensure that the unit is aligned properly. If the shaft is misaligned, you must realign the unit to prevent shaft breakage and damage to bearings, pump casing wearing rings,

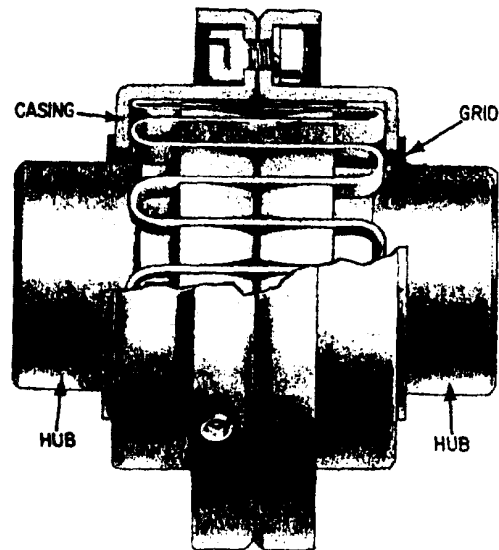

Figure 7-15.—Grid-type flexible coupling.

manufacturer. If the misalignment is excessive, the coupling parts are subjected to severe punishment, necessitating frequent replacement of pins, bushings, and bearings. It is absolutely necessary to have the rotating shafts of the driving and driven units in proper alignment. Figure 7-16 shows coupling alignment.

You should check the shaft alignment when the pump is opened for repair or maintenance, or if a noticeable vibration occurs. You must realign the unit if the shafts are out of line or inclined at an angle to each other. Whenever practicable, check the alignment with all piping in place and with the adjacent tanks and piping filled.

When the driving unit is connected to the pump by a FLANGE COUPLING, the shafting may require frequent realignment, which may be indicated by high temperatures, noises, and worn bearings or bushings.

Wedges, or shims, are sometimes placed under the bases of both the driven and driving units (fig. 7-16, view A) for ease in alignment when the machinery is installed. When the wedges or other packing have been adjusted so the outside diameters and faces of the coupling flanges run true as they are manually revolved, the chocks are

fastened, the units are securely bolted to the foundation, and the coupling flanges are bolted together.

The faces of the coupling flanges should be checked at 90-degree intervals. This method is shown in figure 7-16, view B. Find the distances between the faces at point a, point b (on the opposite side), point c, and point d (opposite point c). This action will show whether the coupling faces are parallel to each other. If they are not parallel to each other, adjust the driving unit or the pump with shims until the couplings check true. While measuring the distances, you must keep the outside diameters of the coupling flanges in line. To do this, place the scale across the two flanges, as shown in figure 7-16, view C. If the flanges do not line up, raise or lower one of the units with shims, or shift them sideways.

The procedure for using a thickness gauge to check alignments is similar to that for a scale. When the outside diameters of the coupling flanges are not the same, use a scale on the surface of the larger flange, and then use a thickness gauge between the surface of the smaller flange and the edge of the scale. When the space is narrow, check the distance between the coupling flanges with a thickness gauge, as shown

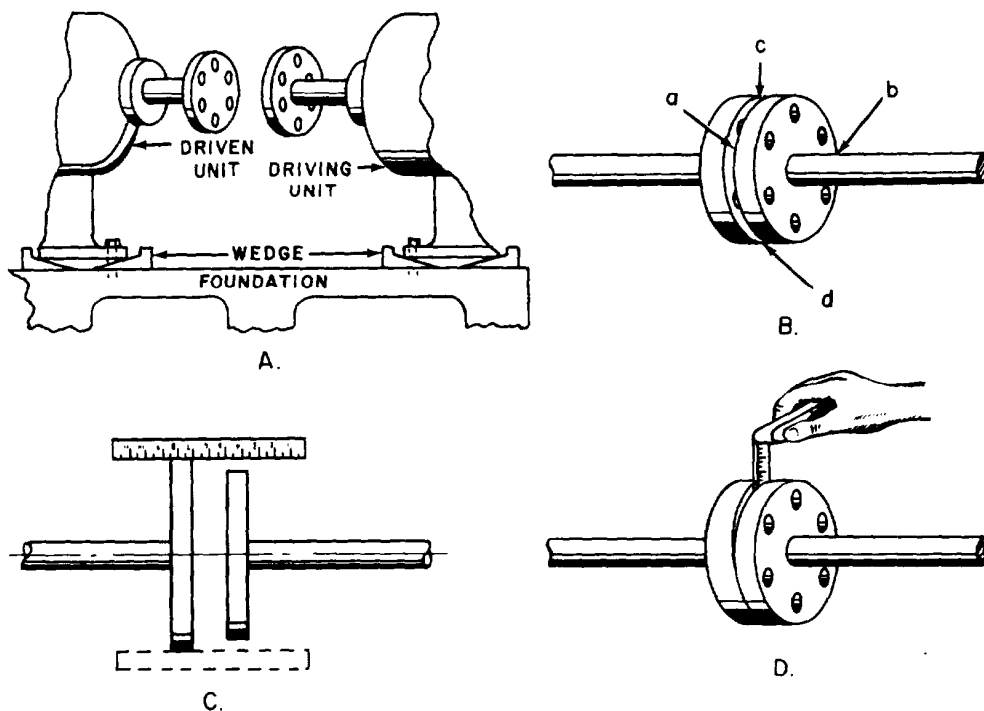

Figure 7-16.—Coupling alignment.

in figure 7-16, view D. Wider spaces are checked with a piece of square key stock and a thickness gauge.

## PURIFIERS

Detailed instructions are furnished with each purifier concerning its construction, operation, and maintenance. When you are responsible for the operation and maintenance of a purifier, study the appropriate manufacturer's technical manual and follow the instructions carefully. In the following section we will discuss general information on the methods of purification and the principles of operation of centrifugal purifiers. Centrifugal purifiers are used for purification of both lube oil and fuel. However, since the principles are the same for both, we will discuss lube oil only.

A purifier may remove both water and sediment, or it may remove sediment only. When water is involved in the purification process, the purifier is usually called a SEPARATOR. When the principal contaminant is dirt or sediment, the purifier is used as a CLARIFIER. Purifiers are generally used as separators for the purification of fuel. When used for purification of a lube oil, a purifier may be used as either a separator or a clarifier. Whether a purifier is used as a separator or a clarifier depends on the water content of the oil that is being purified.

The following general information will help you understand the purification process, the purposes and principles of purifier operation, and the basic types of centrifugal purifiers in use in naval service.

### PURIFIER OPERATION

In the purification of fluid, centrifugal force is the fundamental principle of operation. A centrifugal purifier is essentially a container that is rotated at high speed while contaminated lube oil is forced through, and rotates with, the container. However, only materials that are in the lube oil can be separated by centrifugal force. For example, JP-5 or naval distillate cannot be separated from lube oil, nor can salt be removed from

seawater by centrifugal force. Water, however, can be separated from lube oil because water and lube oil are immiscible (incapable of being mixed). Furthermore, there must be a difference in the specific gravities of the materials before they can be separated by centrifugal force.

When a mixture of lube oil, water, and sediment stands undisturbed, gravity tends to form an upper layer of lube oil, an intermediate layer of water, and a lower layer of sediment. The layers form because of the specific gravities of the materials in the mixture. If the lube oil, water, and sediment are placed in a container that is revolving rapidly around a vertical axis, the effect of gravity is negligible in comparison with that of the centrifugal force. Since centrifugal force acts at right angles to the axis of rotation of the container, the sediment with its greater specific gravity assumes the outermost position, forming a layer on the inner surface of the container. Water, being heavier than lube oil, forms an intermediate layer between the layer of sediment and the lube oil, which forms the innermost layer. The separated water is discharged as waste, and the lube oil is discharged to the sump. The solids remain in the rotating unit.

Separation by centrifugal force is further affected by the size of the particles, the viscosity of the fluids, and the time during which the materials are subjected to the centrifugal force. In general, the greater the difference in specific gravity between the substances to be separated and the lower the viscosity of the lube oil, the greater will be the rate of separation.

### PURIFIER CLASSIFICATION

Two basic types of purifiers are used in Navy installations. Both types use centrifugal force. Principal differences in these two machines exist, however, in the design of the equipment and the operating speed of the rotating elements. In one type, the rotating element is a bowl-like container that encases a stack of discs. This is the disc-type DeLaval purifier, which has a bowl operating speed of about 7,200 rpm. In the other type, the rotating element is a hollow cylinder. This machine is the tubular-type Sharples purifier, which has an operating speed of 15,000 rpm.

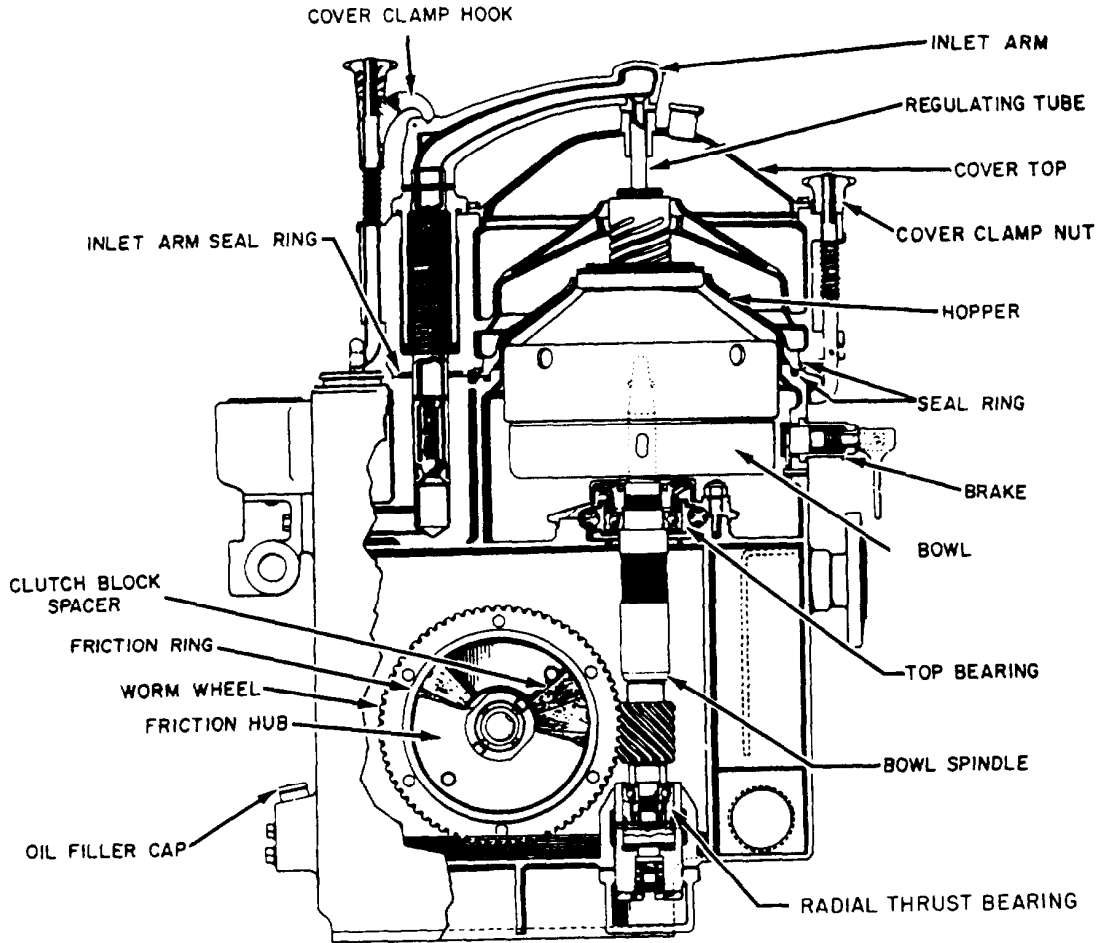

Figure 7-17.—Disc-type centrifugal purifier.

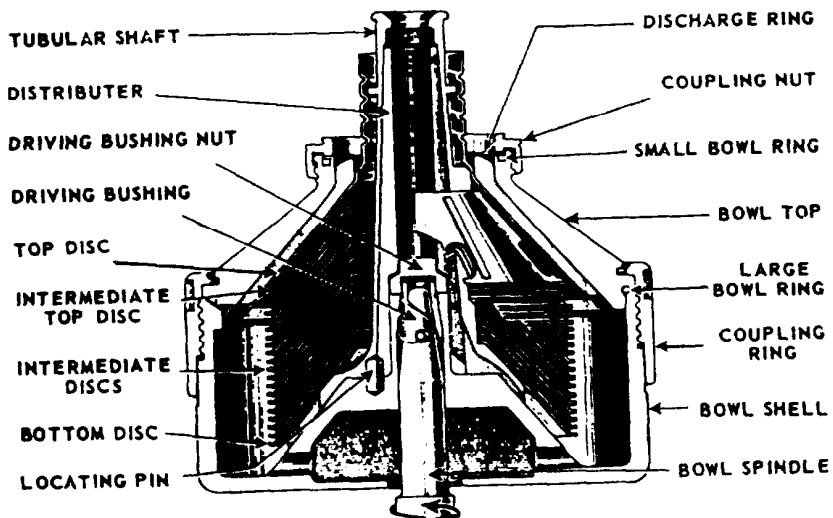

Figure 7-18.—Parts of a disc-type purifier bowl.

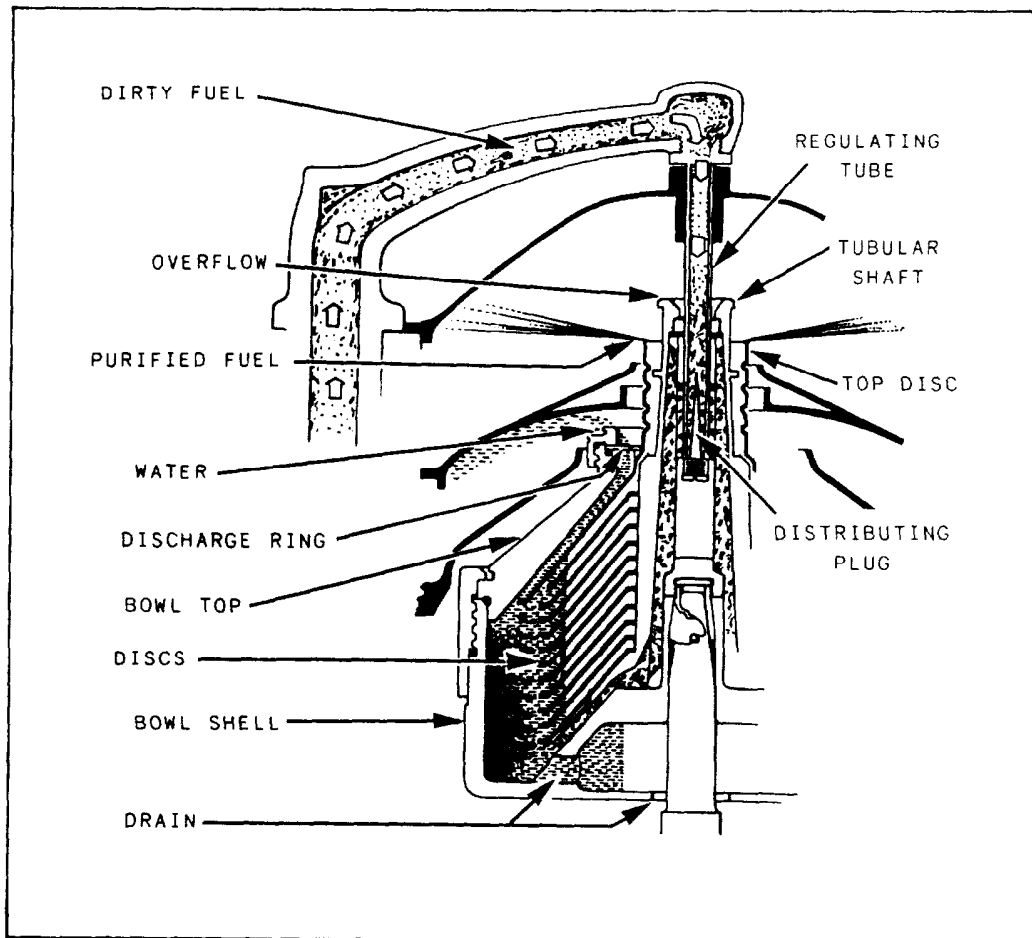

Figure 7-19.—Path of contaminated oil through a disc-type purifier bowl (DeLaval).

### Disc-Type Purifier

Figure 7-17 shows a cutaway view of a disc-type centrifugal purifier. The bowl is mounted on the upper end of the vertical bowl spindle, driven by a worm wheel and friction clutch assembly. A radial thrust bearing at the lower end of the bowl spindle carries the weight of the bowl spindle and absorbs any thrust created by the driving action. Figure 7-18 shows the parts of a disc-type bowl. The flow of fluid through the bowl and additional parts are shown in figure 7-19. Contaminated fluid enters the top of the revolving bowl through the regulating tube. The fluid then passes down the inside of the tubular shaft, out the bottom, and up into the stack of discs. As the dirty fluid flows up through the distribution holes in the discs, the high centrifugal force exerted by the revolving bowl causes the dirt, sludge, and water to move outward. The purified fluid is

forced inward and upward, discharging from the neck of the top disc. The water forms a seal between the top disc and the bowl top. (The top disc is the dividing line between the water and the fluid.) The discs divide the space within the bowl into many separate narrow passages or spaces. The liquid confined within each passage is restricted so it can flow only along that passage. This arrangement minimizes agitation of the liquid as it passes through the bowl. It also forms shallow settling distances between the discs.

Any water, along with some dirt and sludge, separated from the fluid, is discharged through the discharge ring at the top of the bowl. However, most of the dirt and sludge remains in the bowl and collects in a more or less uniform layer on the inside vertical surface of the bowl shell.



## Tubular-Type Purifier

A cutaway view of a tubular-type centrifugal purifier is shown in figure 7-20. This type of purifier consists of a bowl or hollow rotor that

rotates at high speeds. The bowl has an opening in the bottom to allow the dirty fluid to enter. It also has two sets of openings at the top to allow the fluid and water to discharge. The bowl of the purifier is connected by a coupling unit to a

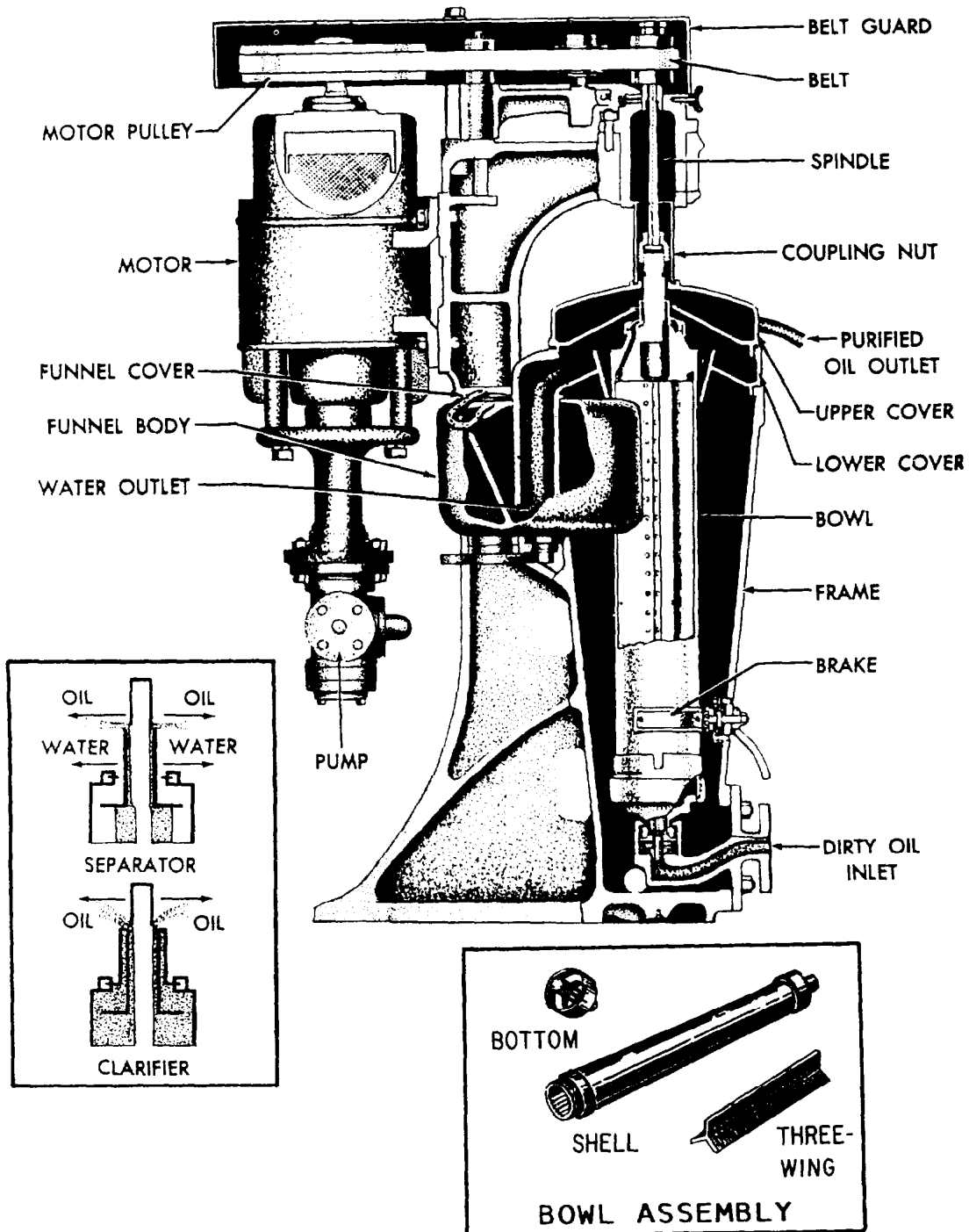

Figure 7-20.—Tubular-type centrifugal purifier.

spindle. The spindle is suspended from a ball bearing assembly. The bowl is belt-driven by an electric motor mounted on the frame of the purifier.

The lower end of the bowl extends into a flexibly mounted guide bushing. The assembly restrains movement of the bottom of the bowl, but it also allows the bowl enough movement to center itself during operation. Inside the bowl is a device with three flat plates that are equally spaced radially. This device is commonly referred to as the **THREE-WING DEVICE**, or just the three-wing. The three-wing rotates with the bowl and forces the liquid in the bowl to rotate at the same speed as the bowl. The liquid to be centrifuged is fed, under pressure, into the bottom of the bowl through the feed nozzle.

After the bowl has been primed with water, separation is basically the same as it is in the disc-type purifier. Centrifugal force causes clean fluid to assume the innermost position (lowest specific gravity), and the higher density water and dirt are forced outward towards the sides of the bowl. Fluid and water are discharged from separate openings at the top of the bowl. Any solid contamination separated from the liquid remains inside the bowl all around the inner surface.

## **GENERAL NOTES ON PURIFIER OPERATIONS**

For maximum efficiency, purifiers should be operated at the maximum designed speed and rated capacity. Since reduction gear oils are usually contaminated with water condensation, the purifier bowls should be operated as separators and not as clarifiers.

When a purifier is operated as a separator, **PRIMING OF THE BOWL** with fresh water is essential before any oil is admitted into the purifier. The water serves to seal the bowl and to create an initial equilibrium of liquid layers. If the bowl is not primed, the oil will be lost through the water discharge port.

Several factors influence purifier operation. The time required for purification and the output of a purifier depend on such factors as the viscosity of the oil, the pressure applied to the oil, the size of the sediment particles, the difference in the specific gravity of the oil, the substances that contaminate the oil, and the tendency of the oil to emulsify.

The viscosity of the oil will determine the length of time required to purify the oil. The more viscous the oil, the longer the time will be to purify

it to a given degree of purity. Decreasing the viscosity of the oil by heating is one of the most effective methods of facilitating purification.

Even though certain oils may be satisfactorily purified at operating temperatures, a greater degree of purification will generally result by heating the oil to a higher temperature. To accomplish this, the oil is passed through a heater, where the proper temperature is obtained before the oil enters the purifier bowl.

Oils used in naval ships may be heated to specified temperatures without adverse effects, but prolonged heating at higher temperatures is not recommended because of the tendency of such oils to oxidize. Oxidation results in rapid deterioration. In general, oil should be heated sufficiently to produce a viscosity of approximately 90 seconds Saybolt universal (90 SSU).

Pressure should **NEVER** be increased above normal to force a high-viscosity oil through the purifier. Instead, viscosity should be decreased by heating the oil. The use of excess pressure to force oil through the purifier will result in less efficient purification. On the other hand, a reduction in the pressure that the oil is forced into the purifier will increase the length of time the oil is under the influence of centrifugal force and will result in improved purification.

The proper size discharge ring (ring dam) must be used to ensure the oil discharged from a purifier is free of water, dirt, and sludge. The size of the discharge ring used depends on the specific gravity of the oil being purified. All discharge rings have the same outside diameter, but have inside diameters of different sizes.

You should obtain specific details of operating a given purifier from the appropriate instructions provided with the unit. The information you have been provided is general and applicable to both types of purifiers.

## **AIR COMPRESSORS**

The air compressor is the heart of any compressed air system. It takes in atmospheric air, compresses it to the pressure desired, and moves it into supply lines or into storage tanks for later use. Air compressors come in different designs and configurations and have different methods of compression. Some of the most common types used on gas turbine ships will be discussed in this chapter.

Before describing the various types of air compressors found on gas turbine ships, we will discuss the composition of air and some of the things air may contain. This discussion should help you understand why air compressors have special features that prevent water, dirt, and oil vapor from getting into compressed air piping systems.

Air is composed mainly of nitrogen and oxygen. At atmospheric pressure (within the range of temperatures for the earth's atmosphere), air is in a gaseous form. The earth's atmosphere also contains varying amounts of water. Depending on weather conditions, water will appear in a variety of forms, such as rain (liquid water), snow crystals, ice (solid water), and vapor. Vapor is composed of tiny drops of water that are light enough to stay airborne. Clouds are an example of water vapor.

Since air is a gas, it will expand when it is heated. Consequently, the heating of air will cause a given amount of air to expand, take up more space (volume), and hold more water vapor. When a given amount of air at a given temperature and pressure is no longer able to soak up water vapor, the air is saturated, and the humidity is 100 percent.

When air cools, its density increases; however, its volume and ability to hold water decrease. When temperature and pressure conditions cause air to cool and to reach the dew point, any water vapor in the air will condense into a liquid state (water). In other words, one method of drying air out is to cool it until it reaches the dew point.

Besides nitrogen, oxygen, and water vapor, air contains particles of dust and dirt that are so tiny and lightweight that they remain suspended in the air. You may wonder how the composition of air directly affects the work of an air compressor. Although one cubic foot of air will not hold a tremendous amount of water or dirt, you should realize that air compressors have capacities that are rated in hundreds of standard cubic feet per minute (cfm). This is a very high rate of flow. When a high flow rate of dirty, moisture-laden air is allowed to enter and pass through an air compressor, the result is rapid wear of the seals and load-bearing parts, internal corrosion (rust), and early failure of the unit. The reliability and useful life of any air compressor is extended by the installation of filters. Filters will remove most of the dirt and dust from the air before it enters the equipment. On the other hand, most of the water vapor in the air at the intake will pass directly through the filter material and will be

compressed with the air. When air is compressed, it becomes very hot. As we mentioned earlier, hot air is capable of holding great amounts of water. The water is removed as the compressed air is routed through coolers. The coolers remove the heat from the airstream and cause some of the water vapor to condense into liquid (condensate). The condensate must be periodically drained from the compressor.

Although the coolers will remove some of the water from the air, simple cooling between the stages of compression (intercooling) and cooling of the airstream after it leaves the compressor (aftercooling) will not make the air dry. When clean dry air suitable for pneumatic control and other shipboard systems is required, air from the compressor is routed through air-drying units. Many air-drying units are capable of removing enough water vapor from the airstream to cause the dew point to be as low as  $-60^{\circ}\text{F}$ . Some of the more common devices used to remove water vapor from the airstream, such as dehydrators, will be explained later in this chapter.

## CLASSIFICATION OF AIR COMPRESSORS

An air compressor may be classified according to pressure (low, medium, or high), type of compressing element, and whether the discharged air is oil-free.

Because of our increasing need for oil-free air aboard ship, the oil-free air compressor is gradually replacing most of the standard low-pressure and high-pressure air compressors. For this reason, we will focus most of our discussion on the features of oil-free air compressors.

According to the *Naval Ships' Technical Manual*, chapter 55 1, compressors are classified as low, medium, or high pressure. Low-pressure air compressors (LPACs) have a discharge pressure of 150 psi or less. Medium-pressure compressors have a discharge pressure of 151 psi to 1,000 psi. Compressors that have a discharge pressure above 1,000 psi are classified as high-pressure air compressors (HPACs).

### Low-Pressure or Ship's Service Air Compressors

Only two types of LPACs are used on gas turbine ships, the screw type and the reciprocating type.

**SCREW TYPE.**—The helical-screw type of compressor is a relatively new design of oil-free air

compressor. It is being installed aboard some of our newer ships, such as the FFG-7 class ships. This low-pressure air compressor is a single-stage positive-displacement, axial-flow, helical-screw type of compressor. It is often referred to as a

screw-type compressor. Figure 7-21 shows the general arrangement of the LPAC unit.

Compression is caused by the meshing of two helical rotors (a male and a female rotor, as shown in fig. 7-22) located on parallel shafts and enclosed

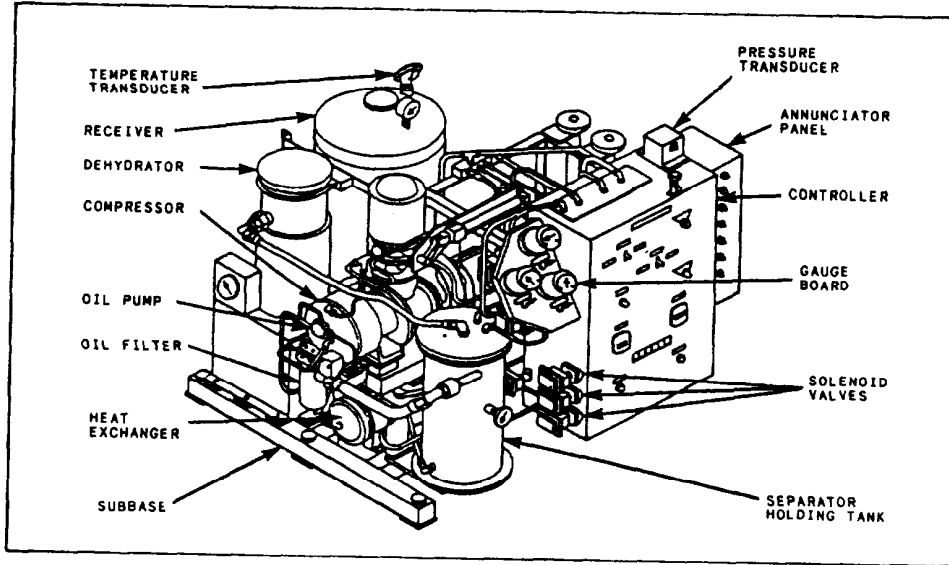

Figure 7-21.—LPAC (screw type).

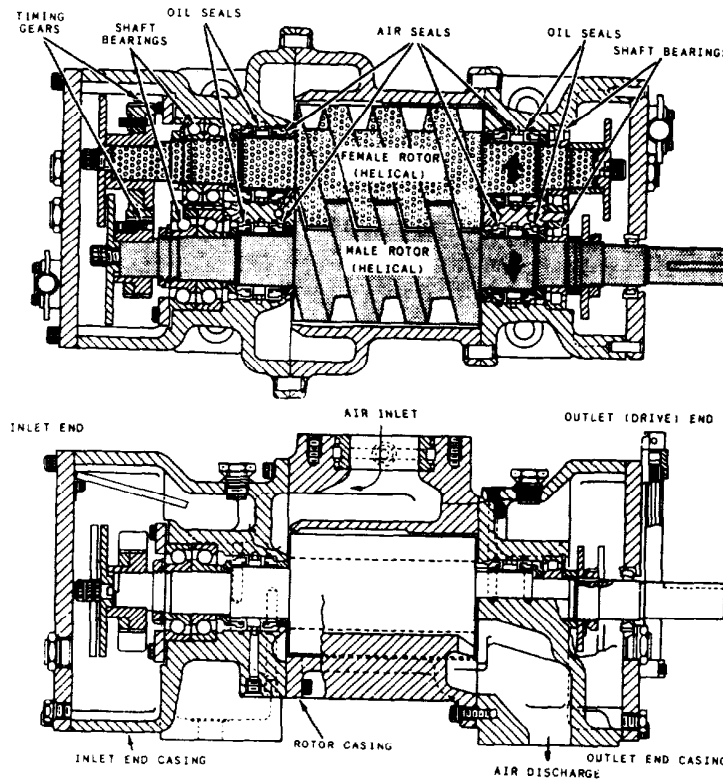

Figure 7-22.—LPAC, compressor section.

in a casing. Air inlet and outlet ports are located on opposite sides of the casing. Atmospheric air is drawn into the compressor through the filter-silencer. The air passes through the air cylinder-operated unloader (butterfly) valve and into the inlet part of the compressor when the valve is in the open (load) position. Fresh water is injected into the airstream as it passes through the inlet port of the compressor casing.

The injected fresh water serves two purposes: (1) it reduces the air discharge temperature caused by compression, and (2) it seals the running clearances to minimize air leakage. Most of the injected water is entrained into the airstream as it moves through the compressor.

The compression cycle starts as the rotors unmesh at the inlet port. As rotation continues, air is drawn into the cavity between the male rotor lobes and into the grooves of the female rotor. The air is trapped in these grooves, or pockets, and follows the rotative direction of each rotor. As soon as the inlet port is closed, the compression

cycle begins as the air is directed to the opposite (discharge) end of the compressor. The rotors mesh, and the normal free volume is reduced. The reduction in volume (compression) continues, with a resulting increase in pressure, until the closing pocket reaches the discharge port.

The entrained water is removed from the discharged air by a combined separator and water holding tank. The water in the tank passes through a seawater-cooled heat exchanger. The cooled water then recirculates to the compressor for reinjection.

During rotation and throughout the meshing cycle, the timing gears maintain the correct clearances between the rotors. Since no contact occurs between the rotor lobes and grooves, between the rotor lobes and casing, or between the rotor faces and end walls, no internal oil lubrication is required. This design allows the compressor to discharge oil-free air.

For gear and bearing lubrication, lube oil from a force-feed system is supplied to each end of the

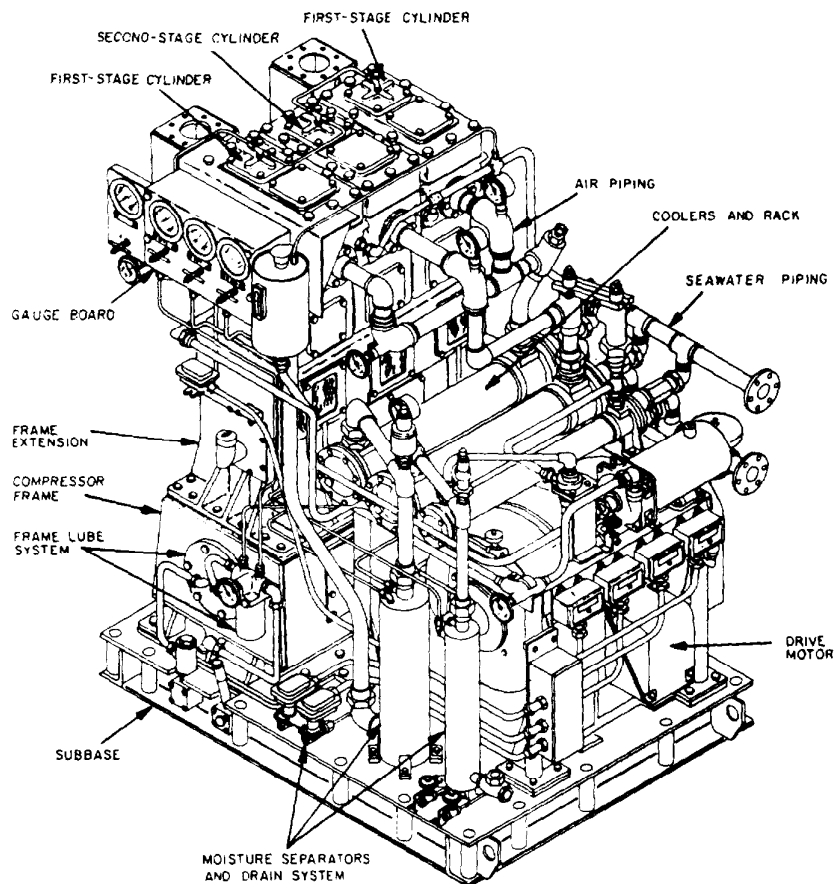

Figure 7-23.—LPAC (reciprocating type).

compressor. Mechanical seals serve to keep the oil isolated from the compression chamber.

**RECIPROCATING TYPE.**—All reciprocating air compressors are similar to each other in design and operation. The following discussion describes the basic components and principles of operation of a low-pressure reciprocating air compressor.

The LPAC is a vertical, two-stage, single-acting compressor that is belt-driven by an electrical motor. Two first-stage cylinders and one

second-stage cylinder are arranged in-line in individual blocks mounted to the crankcase (frame) with a distance piece (frame extension). The crankcase is mounted on a subbase that supports the motor, moisture separators, and a rack assembly. The intercooler, aftercooler, freshwater heat exchanger, and freshwater pump are mounted on the rack assembly. The subbase serves as the oil sump. Figure 7-23 shows the general arrangement of the reciprocating-type compressor.

The compressor is of the crosshead design. Figure 7-24 shows cross-sectional views of

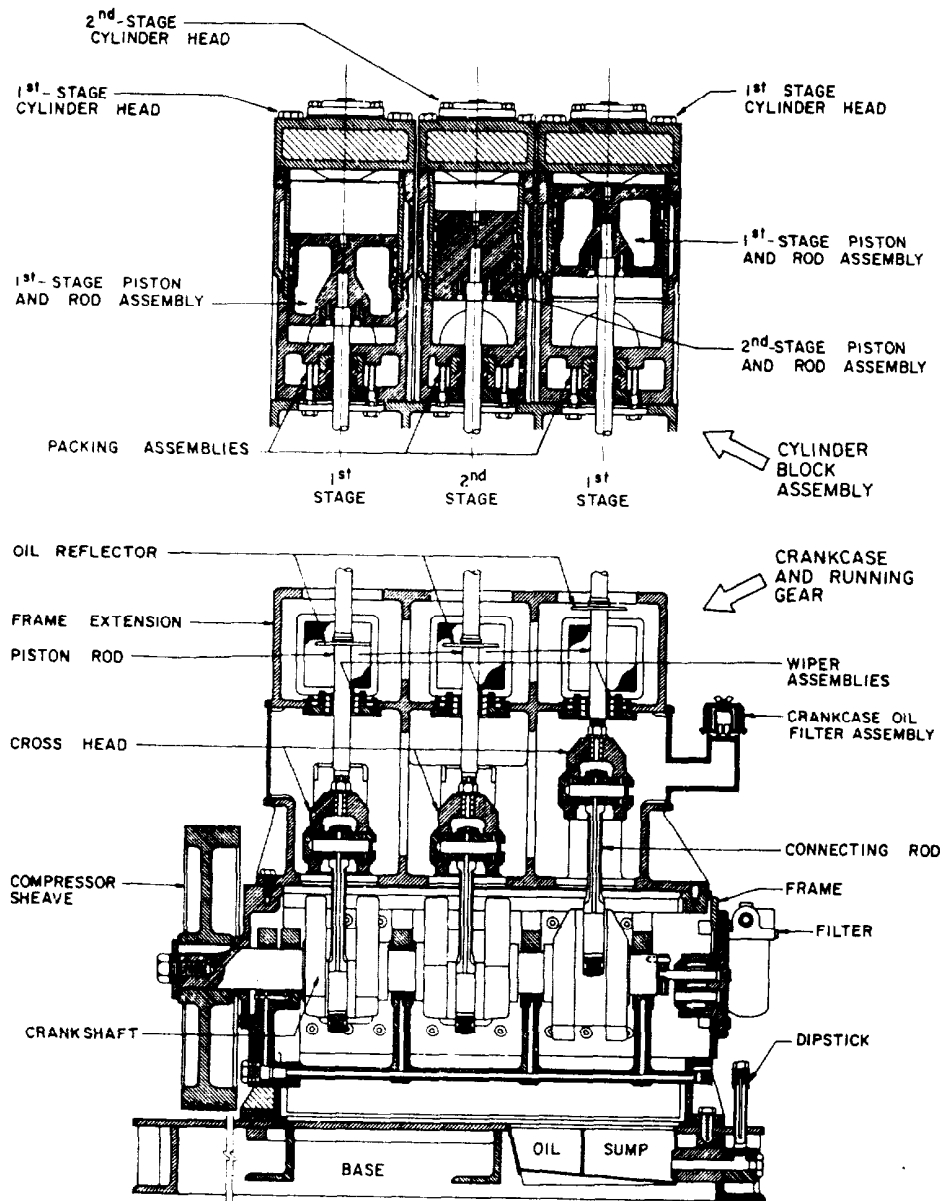

Figure 7-24.—L.P.A.C., cross-sectional views (reciprocating type).

the LPAC. The frame extension houses the crossheads and crosshead guides and is open to the atmosphere. It separates the cylinders, which are not oil lubricated, from the crankcase. Oil wiper assemblies (seals) are located in the frame extension to scrape lubricating oil off the piston rods when the compressor is in operation. Oil deflector plates are attached to the piston rods to prevent any oil that creeps through the scrapers from entering the cylinders. Oil that is scraped from the piston rods drains back to the sump. Air leakage along the piston rods is prevented by full floating packing assemblies bolted to the underside of the cylinder blocks.

During operation, ambient air is drawn into the first-stage cylinders through the inlet filter silencers and inlet valves during the downstroke. When the piston reaches the bottom of its stroke, the inlet valve closes and traps the air in the cylinder. When the piston moves upward, the trapped air is compressed and forced out of the first-stage cylinders, through the first-stage cooler and the first-stage moisture separator. When the

second-stage piston starts its downstroke, the air is drawn into the second-stage cylinder. Then it is further compressed, followed by a cooling and moisture removal process similar to the first stage.

### High-Pressure Air Compressors

The HPAC is a vertical, five-stage, reciprocating air compressor. It is driven by being directly connected to an electric motor. Refer to figures 7-25 and 7-26 as we describe the compressor.

The subbase supports the compressor assembly, the electric drive motor, and the coolers and rack assembly. The crankcase is bolted directly to the subbase and is made up of the frame and frame extension. The frame houses the crankshaft and oil pump. The frame extension is open to the atmosphere and isolates the conventionally lubricated frame from the oil-free cylinders. The crosshead guides are machined in the frame extension. A uniblock casting contains the first three-stage cylinders and is mounted on the frame extension (fig. 7-26). The cylinders are arranged

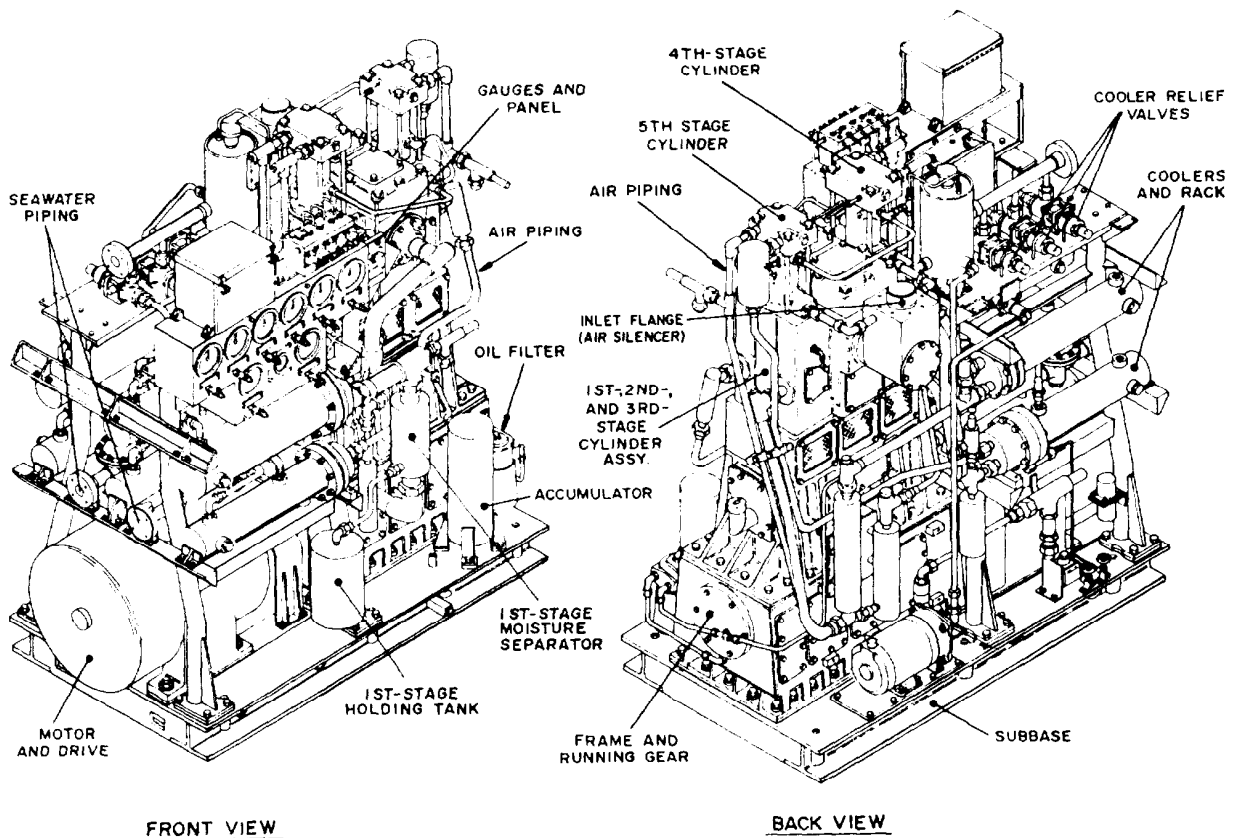

Figure 7-25.—HPAC.

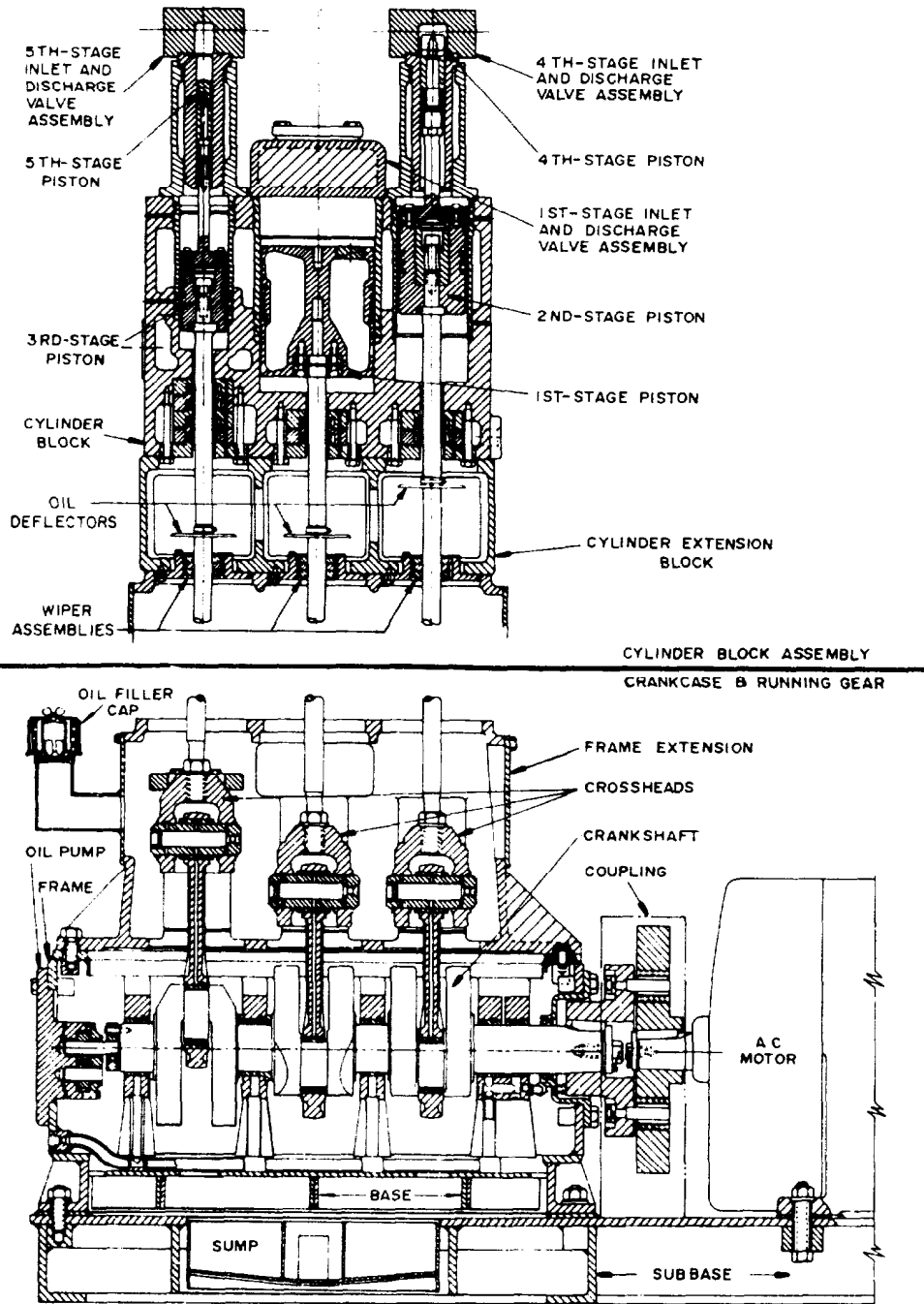

Figure 7-26.—HPAC, cross-sectional views.

in line. The first stage is in the center, the second stage is at the motor end, and the third stage is outboard. The fourth stage is mounted above the second stage, and the fifth stage is above the third stage. The fourth- and fifth-stage pistons are tandem mounted to the second- and third-stage pistons, respectively.

During operation, ambient air is drawn into the first-stage cylinder through the inlet filter and inlet valves. The first stage is double acting, and air is drawn into the lower cylinder area as the piston is moving upward. At the same time, air in the upper cylinder is being compressed and forced out



the upper discharge valve. As the piston moves downward, air is drawn into the upper cylinder; likewise, air in the lower cylinder is being compressed and forced out the lower discharge valve. Compressed air leaves the first-stage discharge valves and flows through the first-stage intercooler, and into the first-stage moisture separator.

The first-stage separator has a small tank mounted on the side of the compressor frame below the gauge panel and has a holding tank mounted below the cooler rack. The separators for the remaining stages handle smaller volumes of air due to compression, and as a result the separators and holding chambers are smaller and are integrated into one tank. Condensate is removed from the air as it collides with the internal tank baffles and collects in the holding chamber.

Air from the first-stage separator is drawn into the single-acting, second-stage cylinder on the upward stroke of the piston. As the piston travels downward, the air is compressed and forced out the discharge valve. The second-stage discharge air passes through the second-stage intercooler into the second separator.

The third stage draws air from the second separator and compresses it in the same manner as in the second stage. Third-stage air enters a pulsation bottle before passing through the third interstage cooler. Pulsation bottles are used after the third and fifth compression stages to minimize the shock effect of inlet and discharge pulses as well as pressure changes due to condensate draining.

After passing through the third interstage cooler and moisture separator, the air is drawn into the fourth-stage cylinder on the downstroke of the piston. As the piston travels upward, the air is compressed and forced out the discharge valve. Then it passes through the fourth-stage intercooler and moisture separator.

Air is drawn into the fifth-stage cylinder on the piston downstroke and is compressed and discharged on the upstroke. The discharge air passes through the fifth-stage pulsation bottle, the aftercooler, the moisture separator, a back-pressure valve, and a check valve before entering the ship's HP piping.

## **MAINTENANCE OF AIR COMPRESSORS**

As a GSE or a GSM, you must be thoroughly familiar with the operational and safety procedures for operating or maintaining an air compressor. Always use the correct EOP when operating an air compressor. Before starting any maintenance or repair work, you should consult the MRCs and the manufacturers' technical manuals. These materials contain information concerning specifications, clearances, procedural steps, and troubleshooting techniques. Compressed air is potentially very dangerous. Remember that cleanliness is of greatest importance in all maintenance that requires the opening of compressed air systems.

## **SAFETY PRECAUTIONS**

Many hazards are associated with pressurized air, particularly air under high pressure. Dangerous explosions have occurred in high-pressure air systems because of DIESEL EFFECT. If a portion of an unpressurized system or component is suddenly and rapidly pressurized with high-pressure air, a large amount of heat is produced. If the heat is excessive, the air may reach the ignition temperature of the impurities (oil, dust, and so forth) present in the air and piping. When the ignition temperature is reached, a violent explosion will occur as these impurities ignite. Ignition temperatures may also result from other causes, such as rapid pressurization of a low-pressure, dead-end portion of the piping system, malfunctioning of compressor aftercoolers, and leaky or dirty valves.

Air compressor accidents have also been caused by improper maintenance procedures. These accidents can happen when you disconnect parts under pressure, replace parts with units designed for lower pressures, and install stop valves or check valves in improper locations. Improper operating procedures have resulted in air compressor accidents with serious injury to personnel and damage to equipment.

You must take every possible step to minimize the hazards inherent in the process of compression and in the use of compressed air. Strictly follow all safety precautions outlined in the

manufacturers' technical manuals and in the *Naval Ships' Technical Manual*, chapter 551. Some of these hazards and precautions are as follows:

1. Explosions can be caused by dust-laden air or by oil vapor in the compressor or receiver if abnormally high temperatures exist. Leaky or dirty valves, excessive pressurization rates, or faulty cooling systems may cause these high temperatures.

2. NEVER use distillate fuel or gasoline as a degreaser to clean compressor intake filters, cylinders, or air passages. These oils vaporize easily and will form a highly explosive mixture with the air under compression.

3. Secure a compressor immediately if you observe that the temperature of the air being discharged from any stage exceeds the maximum temperature specified.

4. NEVER leave the compressor station after starting the compressor unless you are sure that the control and unloading devices are operating properly.

5. Before working on a compressor, be sure the compressor is secured and cannot start automatically or accidentally. Completely blow down the compressor, and then secure all valves (including the control or unloading valves) between the compressor and the receiver. Follow the appropriate tag-out procedures for the compressor control valves and the isolation valves. When the gauges are in place, leave the pressure gauge cut-out valves open at all times.

6. Before disconnecting any part of an air system, be sure the part is not under pressure. Always leave the pressure gauge cut-out valves open to the sections to which they are attached.

7. Avoid rapid operation of manual valves. The heat of compression caused by a sudden flow of high pressure into an empty line or vessel can cause an explosion if oil or other impurities are present. Slowly crack open the valves until flow is noted, and keep the valves in this position until pressure on both sides has equalized. Keep the rate of pressure rise under 200 psi per second.

## DEHYDRATORS

The removal of moisture from compressed air is an important feature of compressed air systems. Some moisture is removed by the intercoolers and aftercoolers, as explained earlier in this chapter. Air flasks and receivers are provided with low-point drains so any collected moisture may drain periodically. However, many shipboard uses for compressed air require air with an even smaller moisture content than is obtained through these methods. Water vapor in air lines can create other problems that are potentially hazardous, such as the freezing of valves and controls. These conditions can occur when air at very high pressure is throttled to a low-pressure area at a high flow rate. The venturi effect of the throttled air produces very low temperatures, which will cause any moisture in the air to freeze into ice. Under these conditions, a valve (especially an automatic valve) may become very difficult or impossible to operate. Also, moisture in any air system can cause serious water hammering (a banging sound) within the system. For these reasons, air dehydrators or dryers are used to remove most of the water vapor from compressed air.

The Navy uses two basic types of air dehydrators and a combination of the two. These air dehydrators are classified as follows:

Type I—Refrigeration

Type II—Heater, desiccant

Type III—Refrigeration, desiccant

Each of these types is designed to meet the requirements specified for the quality of the compressed air to be used in pneumatic control systems or for clean, dry air used for shipboard electronic systems. Specific requirements usually involve operating pressure, flow rate, dew point, and purity (percentage of aerosols and size of particles). We will briefly discuss each of the types of air dehydrators.

### REFRIGERATION AIR DEHYDRATOR (TYPE I)

Refrigeration is one method of removing moisture from compressed air. The dehydrator

in figure 7-27 is a REFRIGERATION DEHYDRATOR or REFRIGERATED AIR DRYER. This unit removes water vapor entrained in the stream of compressed air by causing the water to condense into a liquid that is heavier than air. Air flowing from the separator/holding tank first passes through the air-to-air heat exchanger, where some of the heat of compression is removed from the airstream. The air then moves through the evaporator section of the dehydrator, where the air is chilled by circulating refrigerant. In this unit, the airstream is cooled to a temperature that is below the dew point. This will cause the water vapor in the air to condense so it can be removed by the condensate drain system. After leaving the evaporator section, the dehydrated air moves upward through the cold air side of the air-to-air heat exchanger. In the air-to-air heat exchanger, the dehydrated air is raised in temperature by the

warm air entering the dehydrator. The heating of the air serves to reduce thermal shock as the air enters the system. The exiting dry air flows into the receiver for availability to the ship's air system.

### DESICCANT AIR DEHYDRATOR (TYPE II)

Desiccant is a drying agent. More practically, desiccant is a substance with a high capacity to remove (adsorb) water or moisture. It also has a high capacity to give off that moisture so the desiccant can be reused. DESICCANT-TYPE DEHYDRATORS are basically composed of cylindrical flasks filled with desiccant.

Compressed air system dehydrators use a pair of desiccant towers. One tower is in service

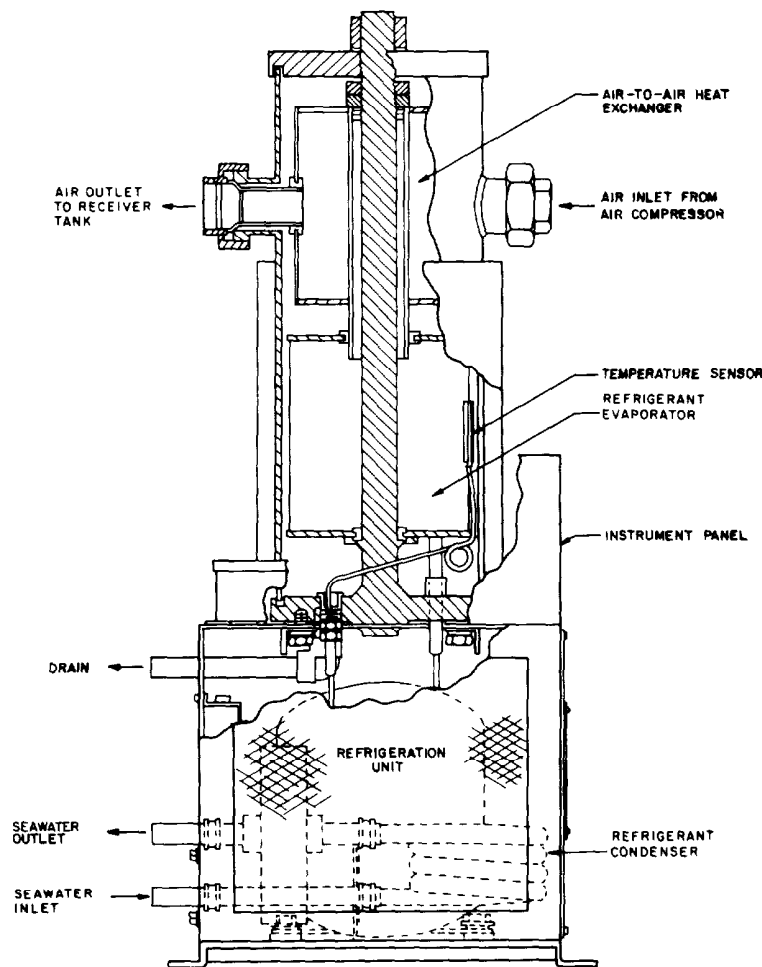

Figure 7-27.—Dehydrator (type I).

dehydrating the compressed air while the other is being reactivated. A desiccant tower is normally reactivated when dry, heated air is routed through the tower in the direction opposite to that of the normal dehydration airflow. The hot air evaporates the collected moisture and carries it out of the tower to the atmosphere. The air for the purge cycle is heated by electrical heaters. When the tower that is reactivating has completed the reactivation cycle, it is placed in service to dehydrate air, and the other tower is reactivated. Figure 7-28 shows a desiccant dehydrator.

### REFRIGERATION AND DESICCANT AIR DEHYDRATOR (TYPE III)

Some installations may use a combination of refrigeration and desiccant for moisture removal.

Hot, wet air from the compressor first enters a refrigeration section, where low temperature removes heat from the airstream and condenses water vapor from the air. The cold, partially-dried air then flows into a desiccant section, where the desiccant absorbs additional moisture from the air.

### WASTE-HEAT BOILER

Steam for ship's services is generated by three waste-heat boilers using the hot exhaust gas from the ship's service gas turbine generators (SSGTGs) as the heat source. The boilers are of the forced-recirculation, water-tube type. Rated steam capacity of each boiler is 7,000 pounds

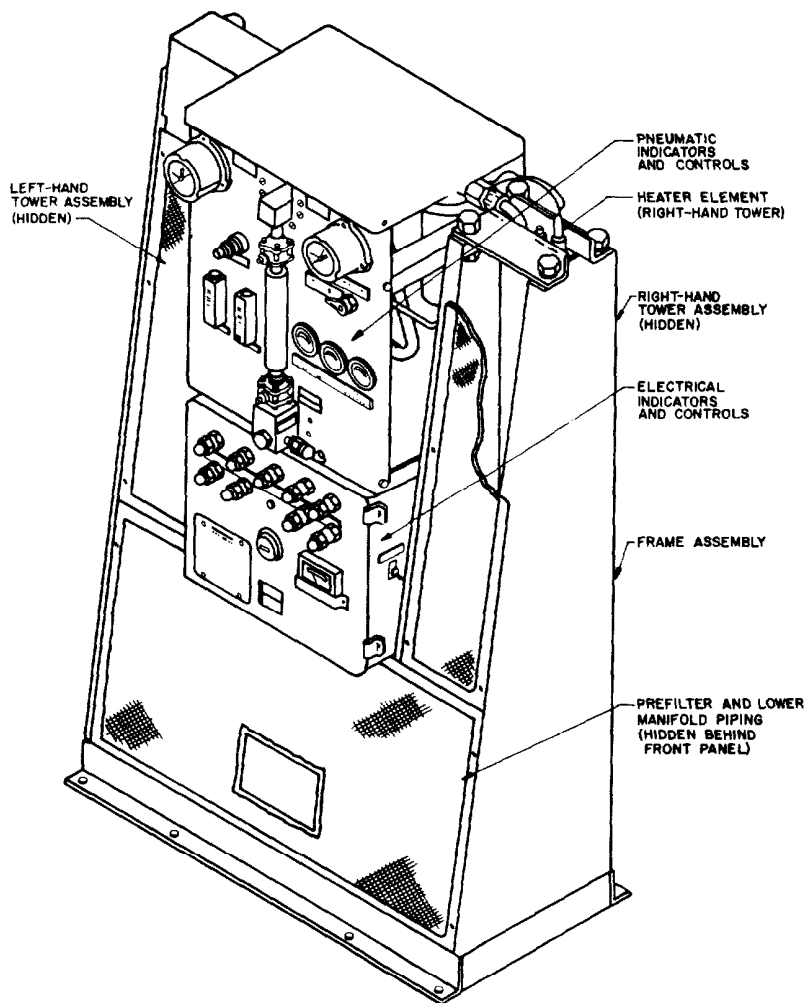

Figure 7-28.—Dehydrator (type II).

per hour (lb/hr) at a nominal operating pressure of 100 psig and a gas inlet temperature of 650 °F.

## BOILER CLASSIFICATION

Two types of waste-heat boilers are used on gas turbine ships. The first type is the Consec boiler and the second type is the Combustion Engineering boiler. Both types of waste-heat boilers operate on the same principle. The exhaust gases of the SSGTGs are used as the heat source to generate steam. For identification

purpose, the Consec boilers found on the DD-963 and DDG-993 class ships have horizontal coils of tubes; the Combustion Engineering boilers found on the CG-47 class ships and the DD-997 class ships have horizontal straight tubes.

## BOILER CONSTRUCTION

In this section we are going to discuss only the Consec boiler. This boiler has a three-piece, gastight casing, the steam-generating coils or tube bundle, and four soot blowers. Hot exhaust gas

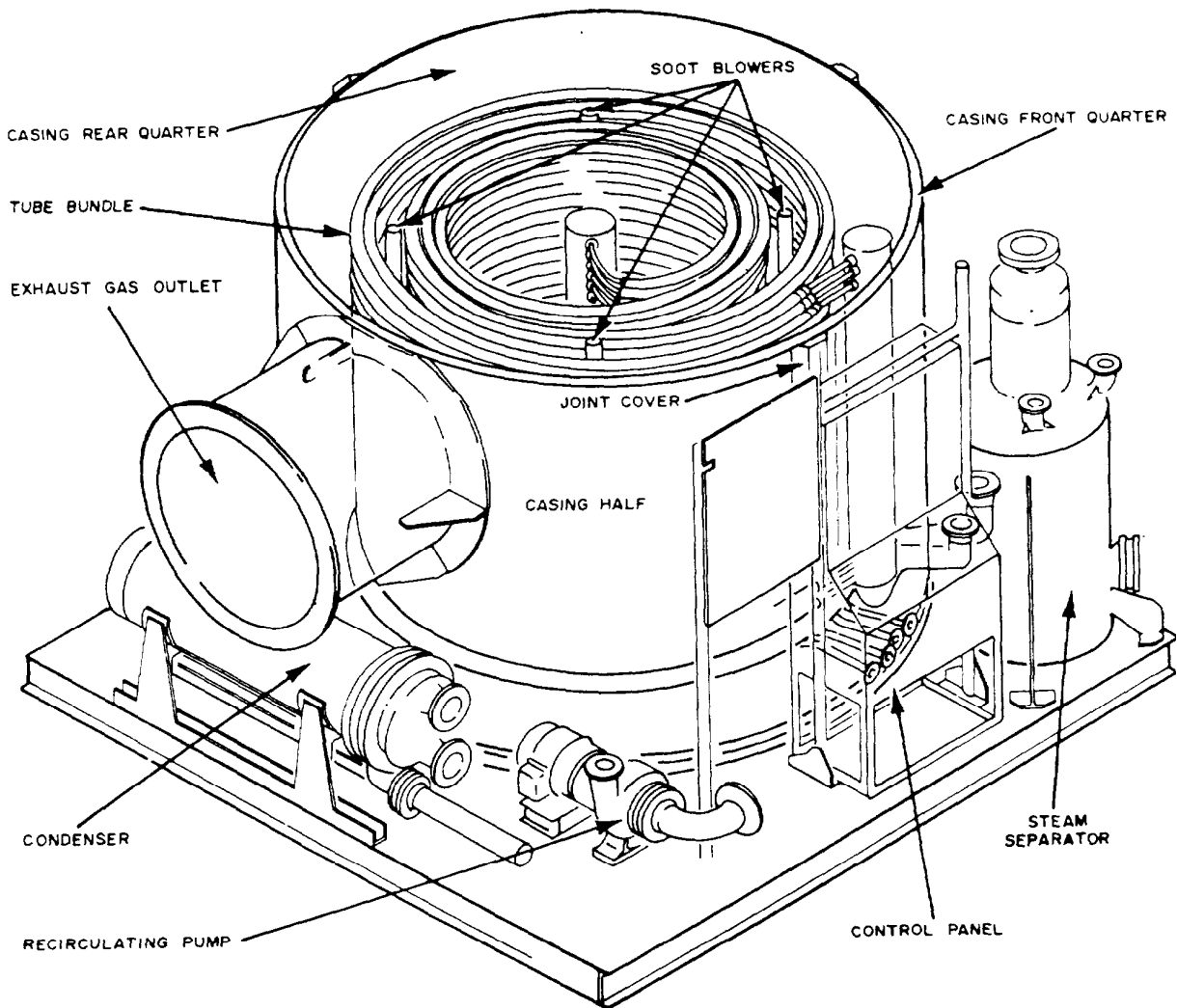

Figure 7-29.—Boiler components.

from the SSGTG enters the boiler from the bottom, passes around and between the boiler tube bundle, heating the water inside the tubes, and discharges through the side of the casing (fig. 7-29).

### Casing

The casing, consisting of a half section and two quarter sections, is made with an inner wall, an outer wall, and a blanket of spun glass insulation sandwiched in between.

Access ports are provided for maintenance and inspection.

### Tube Bundle

The tube bundle (fig. 7-30) is made up of smooth bore, finned tubes. The tubes are wound in flat spiral coils and are assembled to the inlet and outlet headers so the spaces between coils coincide. This arrangement allows the flow of exhaust gas around and between the tubes for maximum heat transfer with minimum pressure drop across the boiler.

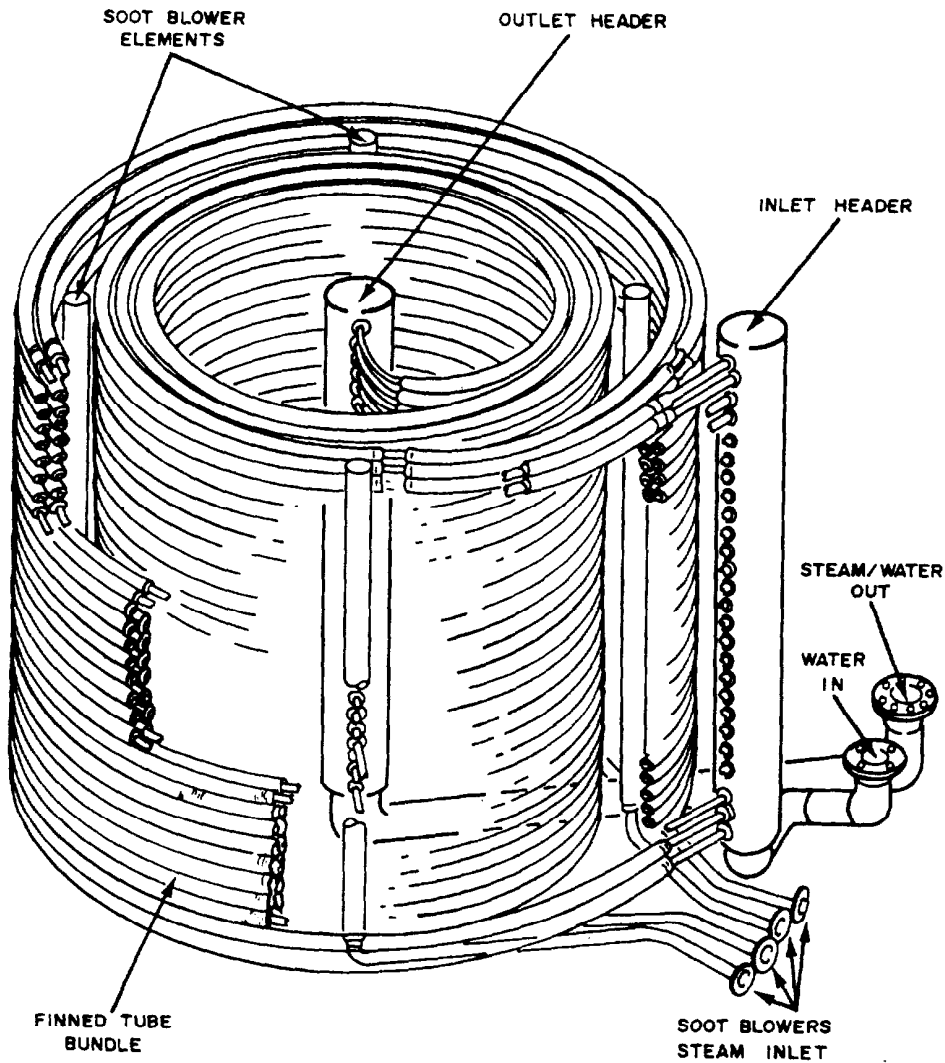

Figure 7-30.—Tube bundle.

## Steam Separator/Water Reservoir

The steam separator/water reservoir (fig. 7-31) is vertically mounted to the base adjacent to the boiler. It has a steam drum or flash chamber with a cyclone centrifugal steam separator, a dry pipe, and steam baffles. Steam separation takes place in the top of the unit, with the steam being discharged into the dry pipe connected to the top of the separator and the water being discharged into the lower part.

In operation, a mixture of steam and water is discharged from the boiler into the steam separator inlet connection, which is at a tangent

to the separator body. The mixture then passes through an orifice within the inlet connection, which causes it to increase in velocity as it enters the separator. Because of the angle of entrance, increased speed, and a helical device within the separator, the mixture acquires a rotary motion. Due to the rotary motion of the mixture, centrifugal force separates the water from the steam. The water, being heavier, is thrown to the sides while the lighter steam remains in the center. An internal baffle further deflects steam to the center and water to the sides. The steam then rises through a scrubber element, which causes the steam to change flow direction several times with

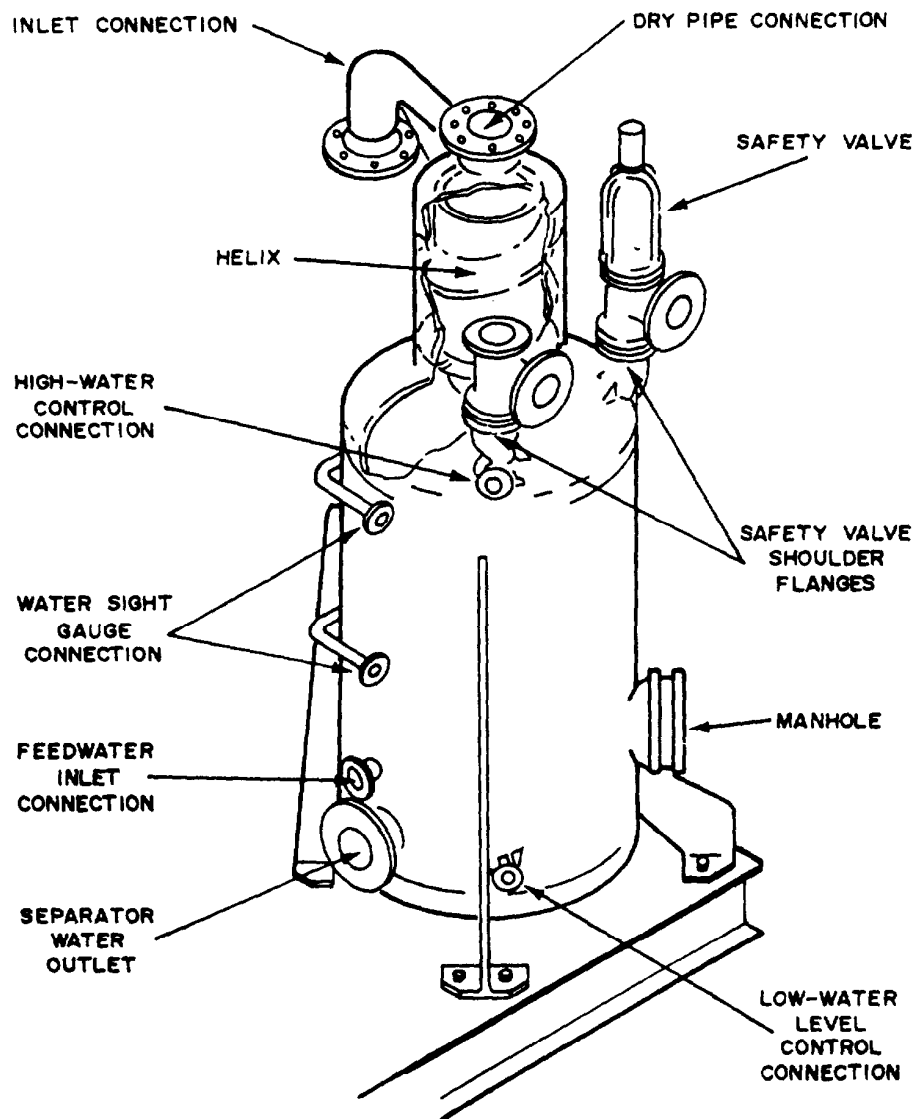

Figure 7-31.—Steam separator/water reservoir.

further removal of moisture. From the scrubber element, the steam passes through an orifice and enters the dry pipe, which carries it to the steam header. The separated water falls to the base of the separator. Vanes in the base of the separator serve to maintain the rotary motion of the water until it is discharged from the outer edge of the separator into the reservoir.

Connections are provided on the steam drum for high- and low-water level control, feedwater inlet, boiler-water outlet, and a water level sight gauge. A manhole provides access for inspection and maintenance. Provision is also made for bottom blowdown and draining. The two safety valves, vertically mounted on the shoulder flanges of the steam separator drum, protect against over-pressurization. The valves are identical except for their pressure settings. Steam discharge from the safety valves is piped to the exhaust gas outlet duct.

### Recirculation Pump

The purpose of the recirculating pump is to provide a continuous flow of water from the

steam separator/water reservoir to the tube bundle and back to the steam separator. The pump is capable of recirculating boiler water at a rate that exceeds the evaporation rate.

### Control Condenser

The purpose of the control condenser is to condense the excess steam resulting from variations of steam demand and exhaust gas temperature. The condenser (fig. 7-32) is a shell/tube design with the coolant (seawater) flowing through the tubes. It has the capacity to condense the total boiler output at all operating conditions.

### Boiler Control Panel

The control panel is an integral part of the waste-heat boiler. It contains the boiler controls, warning lights, an alarm bell, indicating lights, and gauges for local monitoring of all boiler operating parameters and steam distribution

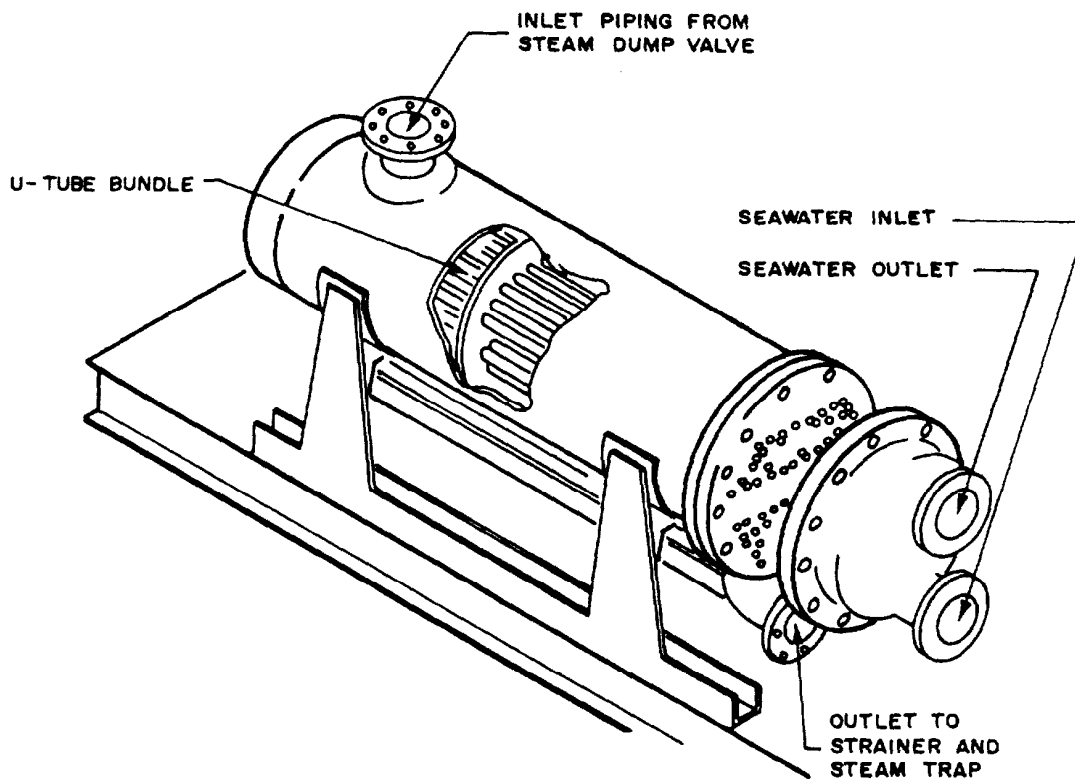

Figure 7-32.—Control condenser.



pressure. Figure 7-33 shows the boiler control panel.

Remote control and monitoring is provided at the propulsion and auxiliary control console (PACC). An emergency stop switch is the only control provided; when depressed, it automatically closes the steam stop valve.

## STEAM PRESSURE CONTROL

Steam pressure control is accomplished through control of the steam dump valve. Steam is discharged from the steam separator into a dry pipe. The steam manifold splits into two lines at a Y connection. One line goes to the steam

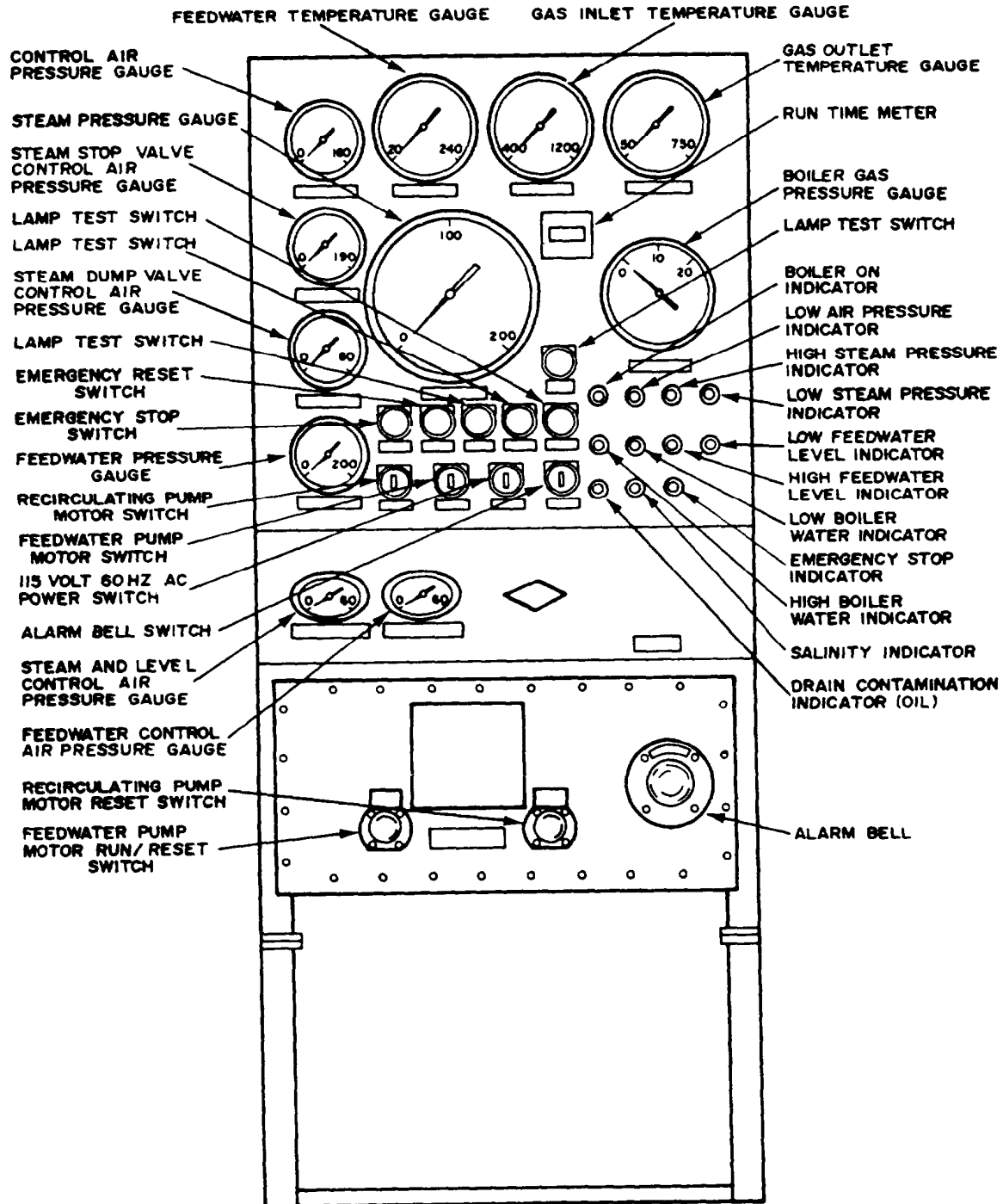

Figure 7-33.—Boiler control panel.

distribution header; the other line goes to the control condenser. The steam stop valve is located in the line to the distribution header; the steam dump valve is located in the line to the condenser. The steam stop valve is normally closed and requires air pressure to open; conversely, the steam dump valve is normally open and requires air pressure to close.

### **Steam Stop Valve**

The steam stop valve is either open or shut. It is actuated by control air from the ship's service air system (SSAS). A solenoid valve, when energized, admits control air to the steam stop valve actuator, opening the valve. De-energizing the solenoid valve blocks the control air and vents the actuator to the atmosphere, causing the stop valve to close.

### **Steam Dump Valve**

The steam dump valve is modulated to control the amount of steam diverted to the control condenser. The steam pressure controller senses steam pressure and regulates control air to position the dump valve. An increase of steam pressure causes a decrease of control air pressure and the dump valve tends to open. This diverts steam to the control condenser, thus reducing steam pressure. A decrease of steam pressure causes an increase of control air pressure and the dump valve tends to close; this increases steam pressure. The steam dump valve can also be manually operated.

### **FEEDWATER CONTROL VALVE**

The feedwater control valve is a normally closed valve that requires air pressure to open. Valve control is automatic; a handwheel is provided for manual operation if a failure occurs.

The feedwater control valve is modulated by the leslie pilot controller to regulate the water level in the boiler (steam separator/reservoir). The leslie pilot controller senses the water level in the steam separator/reservoir as a differential pressure and provides a variable air pressure to the feedwater control valve actuator to control flow. When the water level rises, control air pressure reduces and the feedwater valve tends to close. When the water level drops, control air pressure rises and the valve tends to open.

The control air line to the feedwater control valve has two solenoid-actuated valves. They are

the high-water solenoid valve and the low-water solenoid valve. Both valves are open (energized) during operation.

When boiler low-water level is sensed by a barton gauge micro switch and the water level remains low for 2 minutes, an alarm sounds on the boiler control panel. This condition causes the Leslie pilot controller to route air pressure to fully open the feedwater control valve. When boiler high-water level is sensed by the barton gauge micro switch, a signal is sent to a leslie pilot controller. This causes the control air pressure being supplied to the feedwater control valve actuator to be blocked and vented to the atmosphere. If low-low water level is sensed by the barton gauge, an alarm signal is generated, and the recirculation pump is stopped. The local control panel has low-water, low-low water, and high water level indicators mounted on the front panel section. The PACC only has a summary fault alarm for each boiler.

### **MISCELLANEOUS COMPONENTS**

Some additional components that support the boiler operation are the chemical treatment tank, the blowdown valves, the soot blower system, and the condensate collecting system.

#### **Chemical Treatment Tank**

The chemical treatment tank is provided for chemical treatment of the boiler feedwater. Parameters for boiler-water chemistry are provided in *Naval Ships' Technical Manual*, chapter 220.

Some ships have a continuous chemical injection system installed. It consists of a chemical injection tank that is filled with chemicals that are injected into the system by a proportioning pump.

#### **Blowdown Valves**

Blowdown of the steam separator and the inlet and outlet headers is used for the removal of sludge and sediment. The blowdown is provided for through an outlet on the bottom of the separator and through valves at the low point of each header. The blowdown valves are manually operated. These valves and the associated piping are also used to drain the boiler.

#### **Soot Blowers**

The soot blowers consist of four stationary steam lances positioned vertically between the coils, 90° apart, and are controlled by individual valves. Steam is discharged from holes in the lance arranged so that the steam covers all sides of the

tubes. Soot, carbon, and combustion gas residue are discharged through the exhaust gas outlet.

### **Condensate Collecting System**

The condensate collecting system collects the condensate from the control condensers, distilling plants, and hot-water heating system and returns it through the condensate main to the condensate cooler. This condensate is monitored for salinity. Figure 7-34 is a system schematic showing the flow of condensate, feedwater, and steam through the waste-heat boiler.

**CONTAMINATED DRAIN INSPECTION.**—Condensate from the fuel or lube oil heaters is returned by the oily condensate main. From the oily condensate main, the condensate passes through the contaminated drain inspection tank where it is monitored for the presence of oil contamination before returning to the condensate main. The inspection tank is equipped with a UV oil detector that continuously and automatically monitors the condensate for oil contamination. When oil is detected, the associated solenoid-operated valve diverts the contaminated condensate to the waste-oil drain system. Alarm indicators are located at the control box and the PACC.

The alarm and warning circuits remain activated as long as contamination remains above the set point. However, when contamination drops below the set point, the alarm and warning indicator lights extinguish and the associated solenoid-operated valve closes. The contaminated drain tank is equipped with a sight glass for visual inspection.

**CONDENSATE COOLER.**—The condensate cooler is of the shell and tube design with the coolant (seawater) flowing through the tubes. An air-operated valve in the seawater outlet piping and an air temperature controller regulates the flow of seawater to control the output temperature of the condensate cooler.

**SALINITY INDICATING SYSTEM.**—The salinity indicating system monitors the condensate return system. The system has a bell and dump module, salinity indicator and controllers, and salinity cells for monitoring the control condenser and condensate cooler drains.

**FEEDWATER AND DRAIN COLLECTING TANK.**—The feedwater and drain collecting

tank collects the water from the condensate cooler and maintains a supply of water for the boiler. Makeup feedwater is supplied to the tank from the distilling plant. Additionally, provision is made through an air gap (funnel) to the freshwater system for an emergency supply.

Tank level is automatically controlled by a float-type level controller. When the water level in the tank drops below a set level, the makeup feedwater solenoid valve opens and makeup feedwater flows into the tank. When the tank is full, the makeup feedwater valve closes, thus shutting off the flow of makeup feedwater.

The level controller also contains switches for high- and low-water level indicating lights located on the boiler control panel and at the PACC.

**FEEDWATER PUMP.**—The purpose of the feedwater pump is to supply feedwater to the boiler to maintain the proper water level in the reservoir during boiler operation.

**DEAERATING FEED TANK.**—An addition to the waste-heat boiler that is being installed on all ships at the present time is the deaerating feed tank (DFT) system. The purpose of this system is the removal of gases in the feedwater which, in the case of oxygen, leads to corrosion and pitting of the internal surfaces of waste-heat boiler tubes and other equipment.

The feedwater booster pump takes feedwater from the feed and drain collecting tank and directs it to the subcooler. This feedwater is used to cool the water from the DFT before it enters the feed pump. Feedwater leaves the subcooler and flows through the DFT feed control valve. The DFT feed control valve is an air-operated valve; it controls the flow of feedwater to the DFT. It is used to maintain normal water level in the DFT. A spillover valve is also used to prevent a high-water level from occurring and to maintain a minimum feedwater flow. Feedwater flow from the spillover valve is returned to the feed and drain collecting tank through the condensate cooler.

The deaerated water drops into the storage space at the bottom of the DFT, where it remains until it is pumped to the waste-heat boiler by the feedwater pump. Meanwhile, the mixture of steam plus air and other noncondensable gases travels up. The steam-gas mixture then exits the tank and flows to the external vent condenser. The remaining steam is condensed in the vent condenser and the water is returned to the feedwater holding tank. The air and other noncondensable gases are

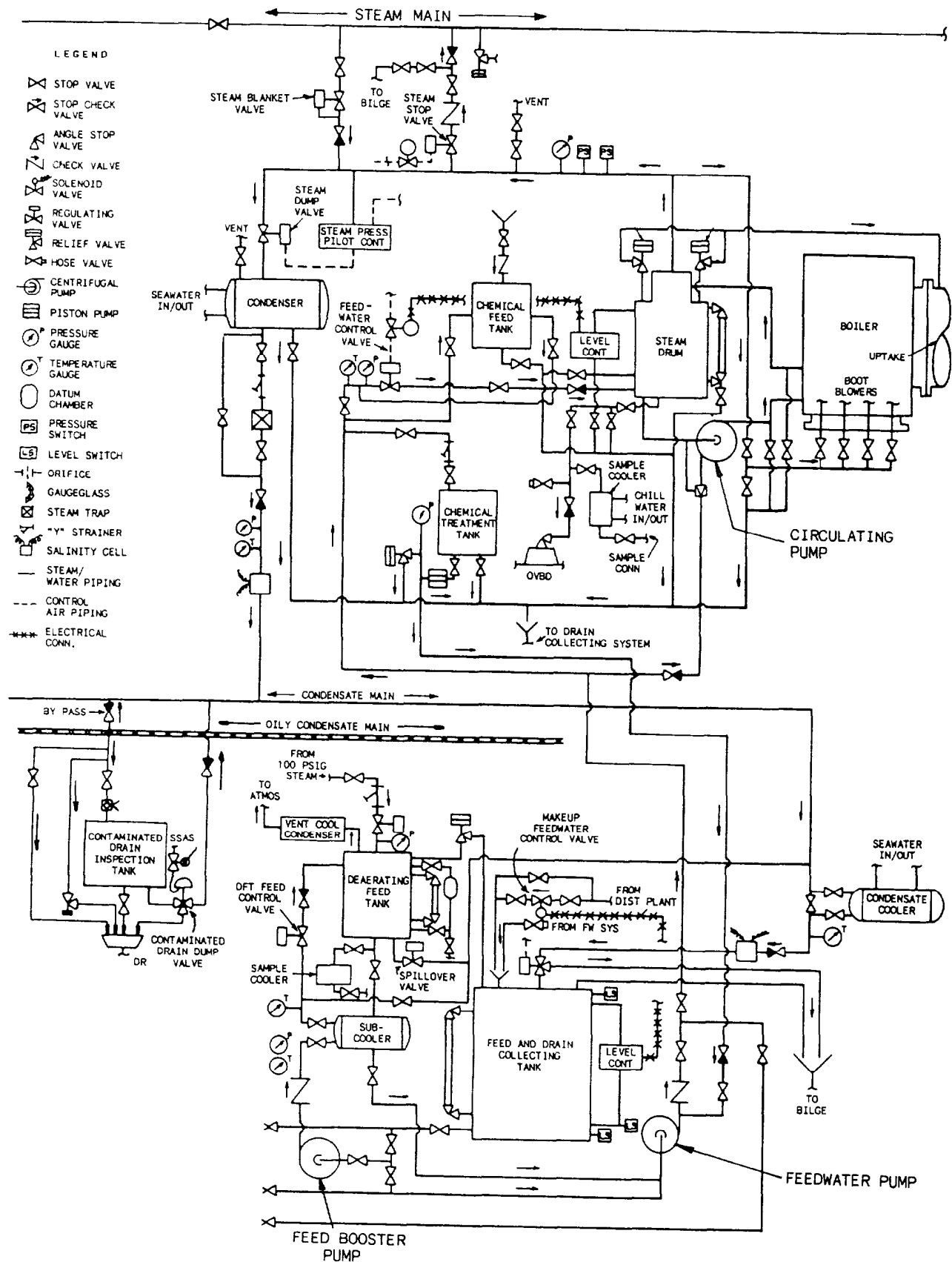

Figure 7-34.—Steam system schematic.

vented to the atmosphere from the shell of the vent condenser.

Detailed procedures for operating and maintaining the waste-heat boiler are furnished by the manufacturers' technical manuals, PMS, and the EOSS. Carefully follow these written procedures when you are operating or performing maintenance on the waste-heat boiler.

## OILY-WATER SEPARATOR

The oily-water separator assembly processes the oily waste water by separating the oil from the water. The process is based on the principle of coalescence. Figure 7-35 shows the general arrangement of the components in the oily-water separator. Oily water is directed through specially constructed filters that provide a surface upon which very small droplets of oil in the water attach and combine (coalesce) with other oil droplets. When the oil droplets grow to sufficient size, they are forced off the exterior surface of the filter by the fluid flow and are separated from the water. The difference in specific gravity

between the water and the oil and gravitational force cause the oil to rise and separate from the water.

The oily-water separator contains the following main elements:

- Motor controller
- Motor-driven pump
- Pressure vessels
- Level detector probes
- Pressure and differential pressure gauges
- Liquid level sensor switch

The pump is a positive-displacement type used to transfer liquid from the oily waste-water holding tank to and through the three separating stages. Mounted on the suction side of the pump is a Y-type strainer to filter out large particles in the fluid before it enters the first stage of the pressure vessels.

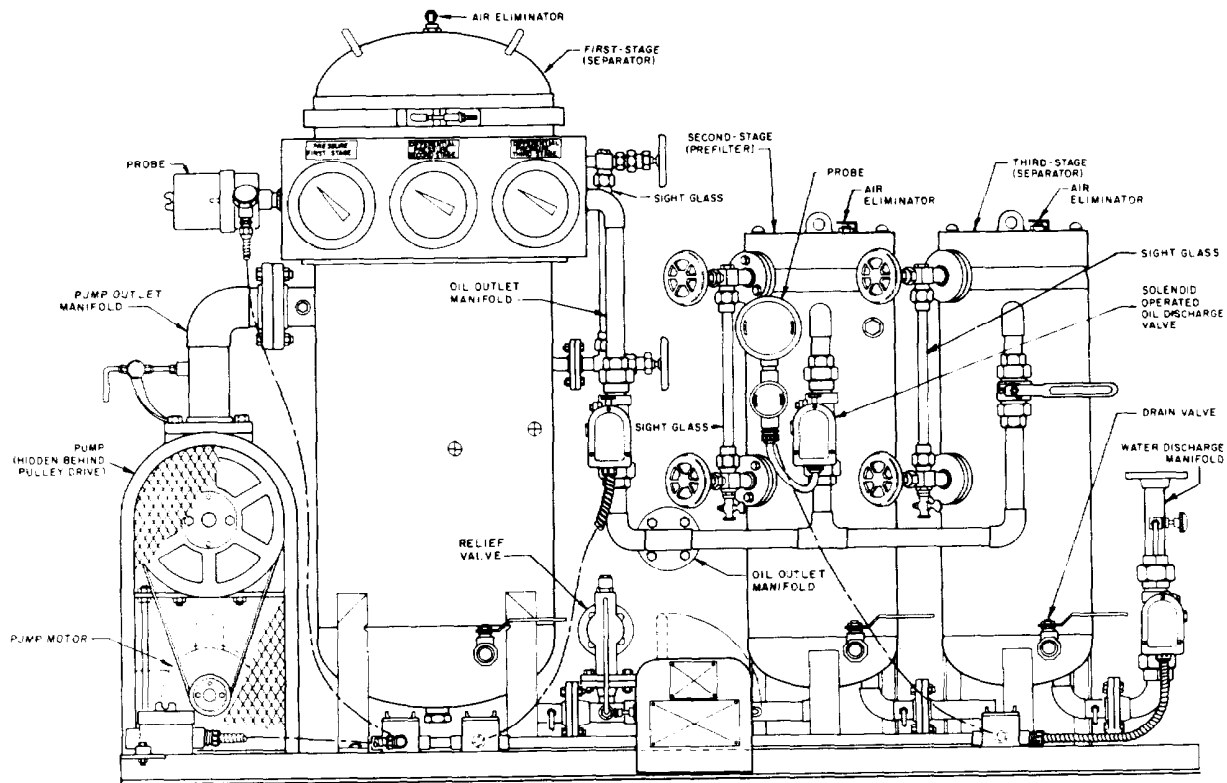

Figure 7-35.—Oily-water separator assembly.

The three pressure vessels (stages) each have a removable cover that provides access to the filter elements. Mounted on each cover is an air eliminator valve to discharge any air displaced by the effluent. Each vessel has a sight glass through which water clarity and oil level can be monitored and a manually operated drain valve for draining the stage. The first-stage vessel has a pressure gauge connected to monitor its fluid outlet pressure. Connected into the second and third stages are differential pressure gauges that indicate the difference between the inlet fluid pressure and the outlet fluid pressure of each stage. The first two stages have a capacitance-type level detector probe that senses an accumulation of oil and electronically signals the opening of the solenoid-operated oil discharge valve.

The fluid enters the first stage (the gravity plate separator), where the primary separation and removal of the oil from water is accomplished. Particulate matter, too small to be separated by the duplex strainer, is removed for the fluid in the first stage. The first stage is designed to significantly reduce the fluid velocity of the incoming oily mixture. The resulting decrease in velocity permits oily-water separation to occur naturally from the effect of gravity. Oil drops in the fluid are separated from the water due to the reduction in fluid velocity that occurs as the fluid exits the inlet line and enters the vessel interior. The oil drops rise and accumulate at the top of the vessel. Oil drops that do not rise to the top of the vessel are removed through coalescence by the inclined adsorption plates on the bottom of the vessel. The plates provide a collection surface upon which any residual oil not gravitationally separated will collect (coalesce) and separate from the flow. Holes drilled in the plates permit the oil droplets to rise to the top of the vessel. Solids are removed from the fluid in this stage. The air displaced by the rising fluid level in the pressure vessel is discharged through the automatic air eliminator valve mounted on the cover of the vessel.

The oil is automatically discharged from the first stage when the level detector probe senses the oil and electronically signals the simultaneous opening of the solenoid-operated oil discharge valve and closing of the solenoid-operated clean water discharge valve. The valves remain in the position until enough oil is discharged to uncover the probe. This causes each valve to return to its original position, the clean water

discharge valve to open, and the oil discharge valve to close.

The processed water effluent from the first stage is discharged into the second-stage prefilter. The second stage, which has a single prefilter element, performs the dual function of removing particulate matter and oil that were not separated in the first stage. The replaceable prefilter element is designed for inside-to-outside fluid flow. As fluid flows from the inside to the outside of the filter element, oil droplets form on the surface of the element. As the oil droplets form to sufficient size, they are forced off the surface by fluid flow. This attach-detach process works solely through fluid flow and requires no moving parts. The detached oil droplets rise and accumulate at the top of the vessel. If an element becomes clogged or its surface chemically contaminated, it is easily replaced. When enough oil collects in this stage to reach the level of the level detector probe, oil is automatically discharged in the same manner as in the first stage.

The processed water next enters the third-stage separator, which is identical to the second stage in its function and operation, except that it is equipped with a manually operated oil discharge valve instead of a solenoid-controlled oil discharge valve. Very little oil will accumulate in the third stage since most, if not all, of the oil will be removed in the first two stages. The third stage serves primarily as a backup to the second stage. The clean water effluent leaves the third stage and enters the water discharge line.

The electrical circuit for the control power that operates the oil level sensors and the solenoid-operated valves is such that only one of the electrically operated valves can be activated at a given time. If simultaneous oil discharge signals from both oil level sensors occur, the logic allows only one stage to discharge oil at any given time. The system operation is fail-to-safe in that all electrically operated valves close without power. The oily-water separator must be manually started, but will be automatically shut down when the liquid level sensor switch in the oily waste water holding tank drops to a preset level.

Detailed procedures for operating and maintaining the oily-water separator are furnished by the EOSS, MRCs, and the manufacturers' technical manuals. Carefully follow these written

procedures when you are operating or performing maintenance on the oily-water separator.

### **SUMMARY**

In this chapter, you have been presented information that describes the basic construction and operation of the different engineering support and auxiliary equipment, such as pumps,

purifiers, air compressors, dehydrators, waste-heat boilers, and oily-water separators. Without the proper operation and maintenance of this equipment, the mission of the ship cannot be accomplished.

The operation and maintenance described in this chapter are not complete or inclusive. You must refer to the manufacturers' technical manuals, PMS, or EOSS for specific operating instructions and maintenance procedures.

## CHAPTER 8

# POWER TRAIN AND CONTROLLABLE PITCH PROPELLER

When we use the term *power train* in our discussions, we are using it as an overall term. This term covers the equipment and various associated components that transmit the power developed by the GTE to the propeller.

The power train of today's gas turbine powered ships will consist of one or more of the following components:

- Main reduction gear (MRG)—reduces the high-power turbine speed to a lower usable shaft speed.

- Clutch and brake assembly—connects the power turbine to the MRG.

- Oil distribution box (OD box)—part of the controllable reversible pitch (CRP) propeller system. It provides a means of sending hydraulic oil and prairie air (PA) through the gear and shaft arrangement to the propeller.

- Propulsion shafting system—transmits propulsion torque to the propeller, the resultant thrust to the thrust bearing, and accommodates the hydraulics system for the CRP propeller. It consists of the

propulsion shafting,

thrust bearing,

line shaft bearings,

bulkhead seals,

stern tube seals and bearings, and

strut bearings.

- Hub-blade assembly—transforms the propulsion shaft rotational torque into axial thrust for ship propulsion. It also provides the mounting

for the propeller blades and contains the hydraulic servomotor mechanism for blade pitch control.

In this chapter, we will describe the power train, its component parts and their functions, and system relationships on gas turbine powered ships. Among the various classes of ships, many variations exist in the types of power trains. The overall function and principle of operation is the same in all of them. Some of these variations are significant enough that they will be covered separately as that class of ship is being discussed.

Upon completion of this chapter, you should have the knowledge supporting the ability to (1) identify and describe the main components of the power trains of today's gas turbine ships; (2) align and operate the GTE support systems; (3) operate the pumps, the turning gears, the oil purification systems, and the engineering control systems from their local operating stations; (4) check system performance; and (5) perform preoperational checks and preventive maintenance on the oil system.

### MAIN REDUCTION GEAR (DD, DDG, AND CC CLASS SHIPS)

On these class ships, the MRGs transmit the power developed by the propulsion GTEs to the propulsion shafts. An MRG and its associated equipment are located in each engine room. The MRG performs two major functions:

- It provides the flexibility of driving each propulsion shaft with either one or two GTEs.

- It reduces the high-speed rotation from the gas turbines to the low speed required for propeller efficiency.



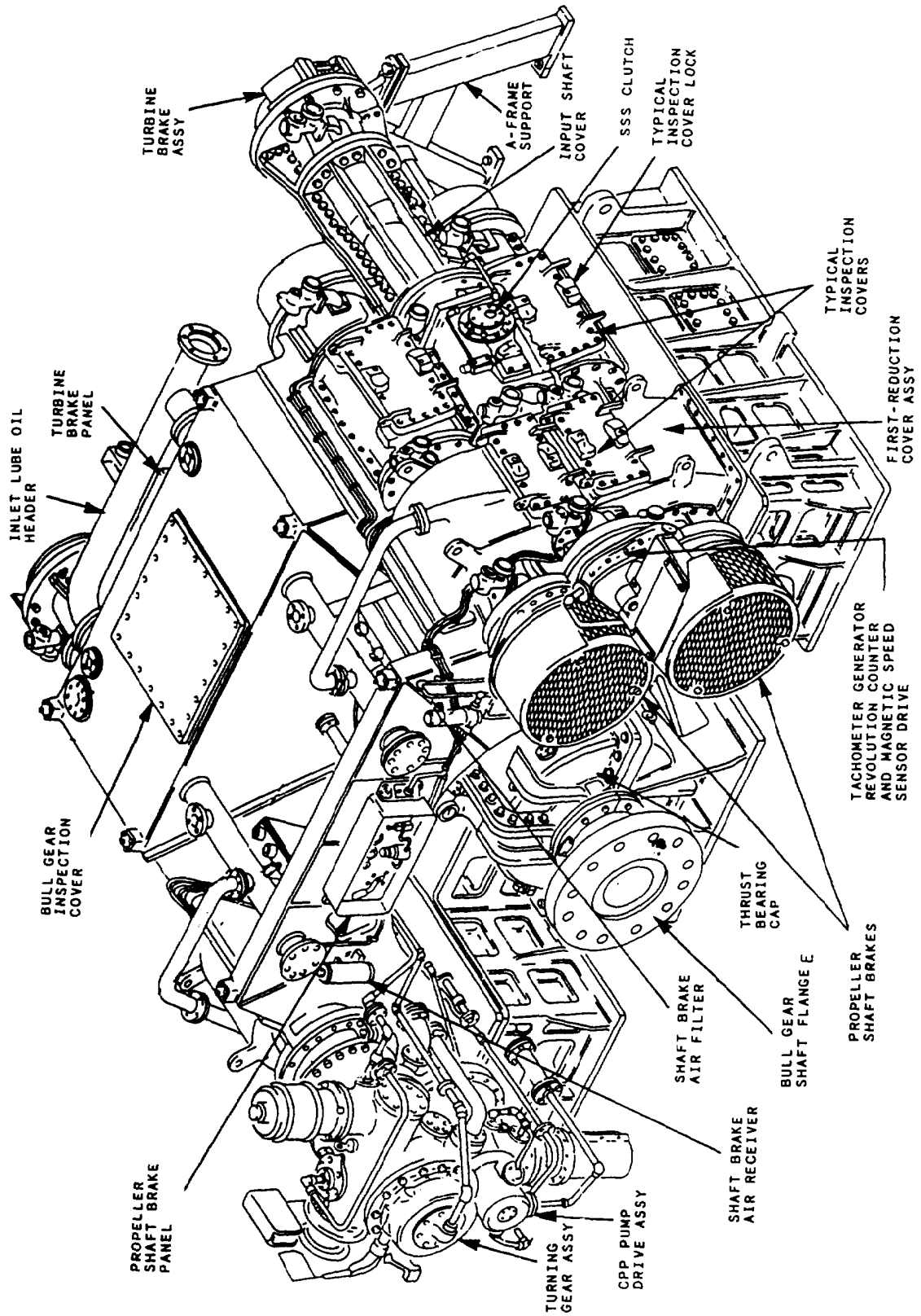

Figure 8-1.—Main reduction gear.

Figure 8-1 shows a typical MRG. This figure does not show the MRG in the proper perspective as to size. A typical MRG is 15.5 feet long, 16.75 feet wide, 13 feet high, and can weigh as much as 57.5 tons (115,000 pounds).

Multiple shaft ships have special needs when it comes to the design of the power train. To prevent steering problems or a tendency for the stern section of the ship to **walk** in the direction of shaft rotation requires that the shafts and

propellers produce what we call **inboard rotation**. That is, when viewed from the propeller end looking forward, the port shaft should rotate clockwise and the starboard shaft should rotate counterclockwise. The GTEs all rotate in the same direction. This requires the MERs to be arranged with the port and starboard MRGs installed in reverse directions with respect to each other. This provides the required inboard shaft rotation. For clarity, figure 8-2 shows the rotating elements of

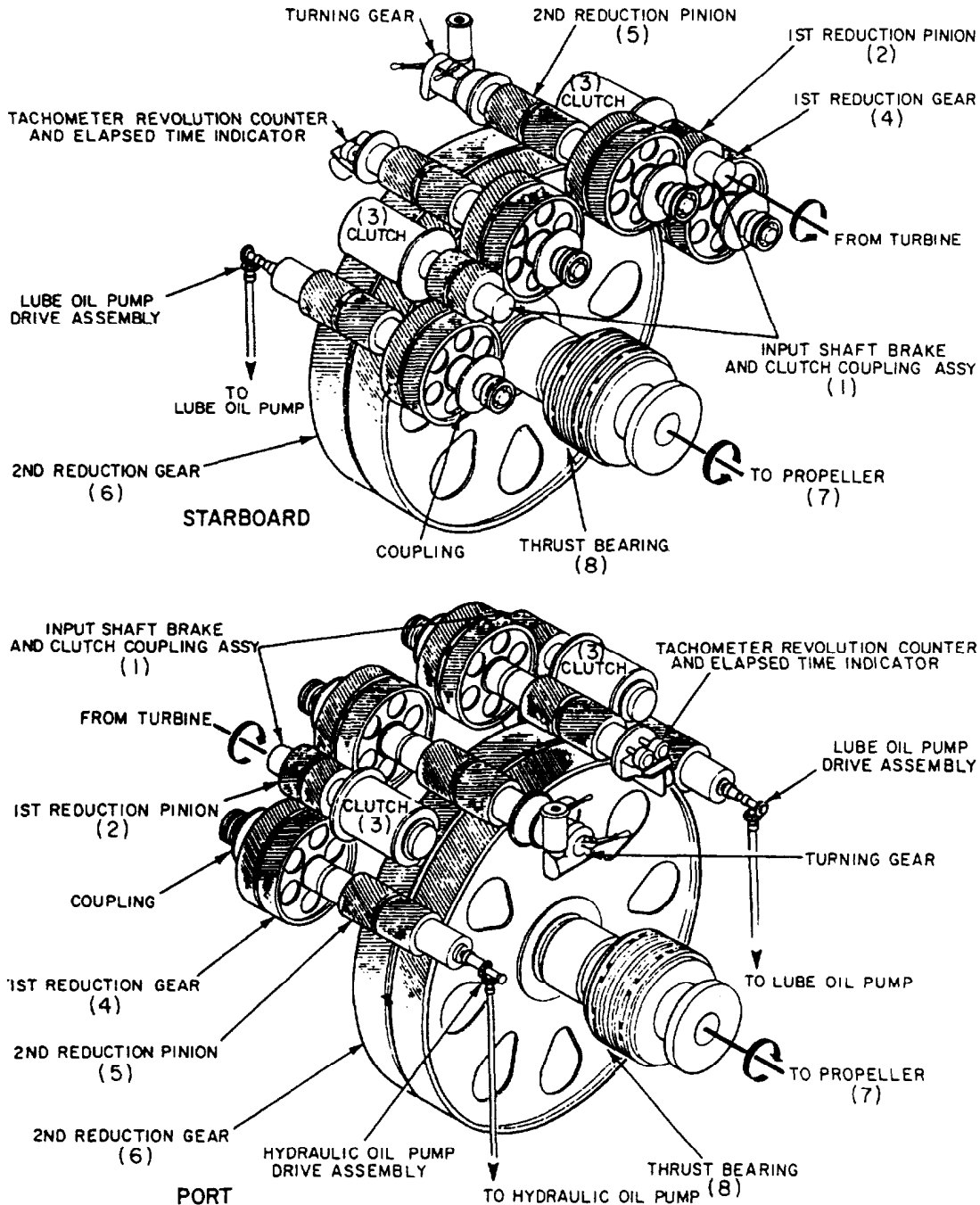

Figure 8-2.—Rotating elements.

a typical multishaft ship's port and starboard MRG.

Numerous times you will be asked to describe the MRG. An acceptable description would be that it is a double-helical, articulated, double-reduction, locked-train reduction gear with a 21.49-to-1 reduction ratio. Double-reduction gear sets are used when the overall speed reduction ratio exceeds 10 to 1.

To better understand the rotating elements of the MRG, refer to figure 8-2 as the name and function of each element is pointed out. The two high-speed input shafts (1) each drive a first-reduction (high-speed) pinion (2) through a clutch or clutch/brake assembly (3). The two first-reduction pinions each drive two first-reduction (intermediate) gears (4). The four first-reduction gears drive the four second-reduction pinions (5) through internal quill shafts and flexible couplings. All four second-reduction pinions drive a common second-reduction (low-speed) gear, commonly referred to as the **bull gear** (6). The bull gear shaft is directly coupled to the propulsion shaft (7). Integral with the bull gear shaft is a thrust collar, not shown on figure 8-2. The thrust collar transmits the fore and aft thrust from the propeller via the propulsion shaft to the thrust bearing (8). The thrust bearing assembly is external to the reduction gear case. It is bolted directly to the propulsion bedplate aft of the gear case.

First-reduction gear elements are referred to as high-speed (HS) elements and the second-reduction gear elements are referred to as low-speed (LS) elements. Figure 8-3 shows how the HS gear and LS pinion are connected by a quill shaft and an articulated flexible coupling to form a subassembly we call an **intermediate assembly**. Two intermediate assemblies provide a dual or twin torque path in the power train from each GTE. This arrangement, known as **locked train**, does not permit independent axial or rotational movement of the pinions. Each locked train must be timed to be sure that the load divides equally between the two intermediate assemblies.

Mounted on the forward end of each MRG at the end of the bull gear shaft is the OD box. The OD box is part of the CRP propeller system. The OD box serves two purposes:

- It sends hydraulic oil and PA through the rotating bull gear shaft and propulsion shaft to the propeller hub.
- It positions a valve rod within the propulsion shafting to control pitch.

On the DD and DDG-993 class ships, clutch/brake assemblies provide the means to engage, disengage, stop power turbine rotation, or stop the propulsion shaft. The CG and FFG, and DDG-51 class ships use a synchro-self-shifting (SSS) overrunning clutch to perform the same actions as the clutch/brake assemblies on the DD and DDG-993 class ships.

An attached hydraulic oil pump for the CRP propeller system is driven off the lower outboard second-reduction pinion shaft. An attached lube oil pump is driven off the lower inboard second-reduction pinion. Both pumps are directly driven via bevel gears and flexible couplings and are connected through manually operated disconnect couplings. A turning gear assembly is connected to the upper outboard second-reduction pinion. The upper inboard second-reduction pinion drives the tachometer generator, revolution counter, and elapsed time indicator.

## GEAR CASING

The gear casing is a fabricated steel plate structure that encloses and supports the rotating gear elements. A lube oil header is mounted on top of the upper casing. It supplies lube oil for the gears, bearings, SSS clutch, and clutch brake assemblies. An opening on the bottom allows the lube oil to drain to the external sump. Covered inspection ports permit visual observation of the lube oil impingement on the gear meshes and also permit gear inspection. The GTMs and the MRG are mounted on a common bedplate and are aligned before installation on the ship. The casing is secured to the bedplate by eight shock and noise attenuating vertical supports attached to the bedplate and the base.

## INPUT SHAFTS

The port and starboard input shafts are identical on each MRG. Each input shaft is a flanged shaft mounted in two journal (sleeve) bearings. One end of the shaft is coupled to the GTE. A turbine brake disc is attached to this end of the shaft. The opposite end of the shaft is attached to the SSS clutch. A removable cover is provided for access to the main section of the shaft. A triseal shaft seal is mounted at the turbine end of the shaft to prevent oil leakage. This seal is designed as two halves that can be removed without removing the shaft or the bearings.

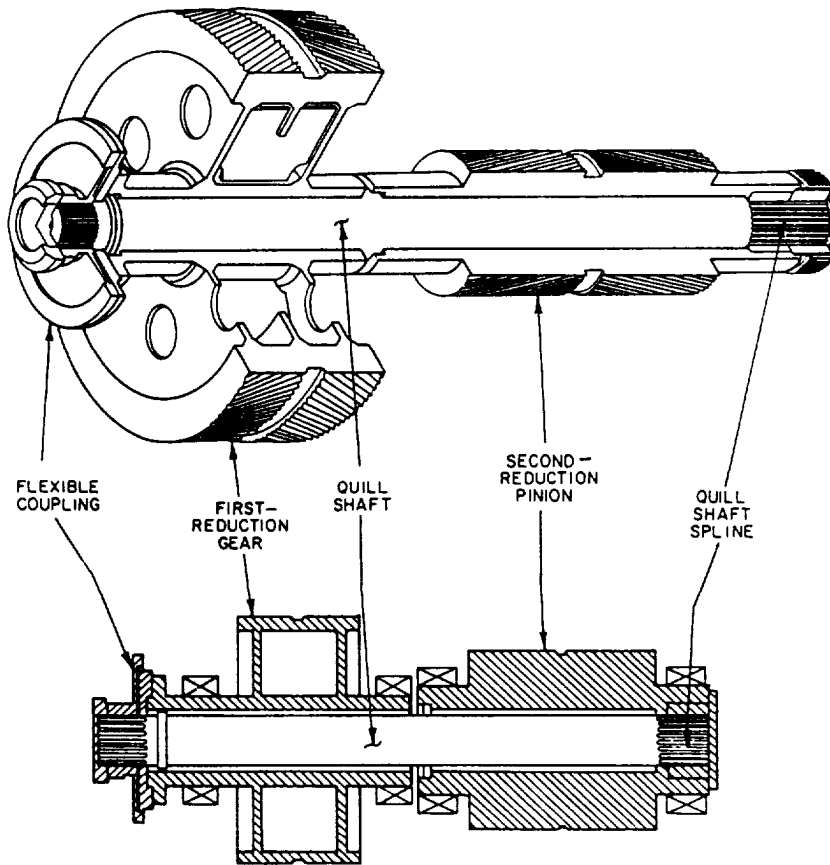

Figure 8-3.—Intermediate assembly.

## HIGH-SPEED PINIONS

The port and starboard HS pinions are identical. Each pinion has double helical teeth for driving its associated first-reduction gears. The shaft is mounted in two sleeve bearings. An SSS clutch oil supply shaft is mounted on the inside of the HS pinion. This shaft is designed to provide lube oil to the SSS clutch. On the starboard side, the HS pinion also drives the tachometer generator, revolution counter, and magnetic speed sensor drive. On the port side, the HS pinion is connected to the output of the turning gear. With this type of connection, motion is transferred through the port HS pinion to the remaining gears and pinions when the turning gear is being operated.

## FIRST-REDUCTION GEARS

The port and starboard first-reduction gears are identical. Each gear has double helical teeth driven by the high-speed pinion. The

first-reduction gear is mounted on the same shaft with the second-reduction pinion. The first-reduction gear portion of the shaft is mounted in two sleeve bearings. A quill shaft is mounted inside of the first-reduction gear and second-reduction pinion shaft. The quill shaft is rigidly attached at the first-reduction gear end and connected at the second-reduction pinion end by a dental coupling.

Each starboard quill shaft has a brake disc for a propeller shaft brake. The lower port quill shaft drives the controllable pitch propeller (CPP) hydraulic pump drive.

## SECOND-REDUCTION PINIONS

The port and starboard second-reduction pinions are identical. Each pinion has double helical teeth for driving the bull gear. The second-reduction pinion is mounted on the same shaft with the first-reduction gear. The second-reduction pinion portion of the shaft is mounted in two sleeve bearings.

## BULL GEAR

The bull gear has double helical teeth that are driven by the four second-reduction pinions. It may also be driven singly by either two port or two starboard second-reduction pinions. The bull gear shaft is mounted in two sleeve bearings. A pivoted shoe thrust bearing directs the propeller shaft thrust, and its resulting thrust on the bull gear and shaft assembly, to the foundation. A second function of this thrust bearing is to maintain axial position of the bull gear and shaft assembly.

A split bearing cap is provided for the thrust bearing. One half of the bearing cap contains provisions for mounting a sight flow indicator for monitoring the flow of lube oil to the bearing. The other half of the bearing cap contains two RTE connectors for remote monitoring of the operating temperature of the ahead and reverse shoes of the thrust bearing. One of the RTE elements is located in the forward shoe and one is located in the aft.

## BEARINGS

Rotating elements of the MRG (input shafts, HS pinions, second-reduction pinions, bull gear, and so forth) are supported by bearings secured by bearing caps. They are called journal (sleeve) or tilt-pad bearings. The bearings (or bearing) that evenly distribute the axial and radial torque of the propeller shaft are called main thrust bearings. A removable bearing cap is provided for each bearing. The bearing caps contain provisions for mounting sight flow indicators for monitoring the flow of lube oil to the bearings. Each bearing is designed in two halves so the bearing can be removed without removing the shaft. One half of each bearing contains an RTE that monitors the operating temperature of the bearing.

### Journal Bearings

The bearings supporting the first-reduction gears, second-reduction pinion, and second-reduction gear are split in half and doweled together. The shells are steel with a tin-based babbitt lining for the bearing surface. Drilled passages through the shell and lining provide a flow path for lube oil. Reliefs in the babbitt lining extend from the oil supply port to the ends of the bearing. This arrangement assures distribution of lube oil across the full surface of the journal.

All gear elements, except for the input shafts and first-reduction pinions, are supported by conventional babbitt-lined sleeve bearings. The bearing bores are machined concentric to the outside diameter and are designed for rebabbiting. Each bearing is marked with its crown thickness at the time of manufacture. Bearing shells are made in halves and doweled, serialized, and match marked to ensure proper assembly. Oil spreader grooves are machined at the joints. Oil is admitted to the bearing surfaces through passages at the split line and distributed axially along the journal by the spreader groove. Grooves are provided at the ends of the spreader grooves to allow the flushing of foreign particles out of the bearing area. Holes are tapped in the bearing shells for inserting lifting eyes. Antirotation pins are used to position the bearing shells at installation and to prevent axial movement or rotation of the bearing shell during operation. Figure 8-4 shows the construction of a typical sleeve bearing.

The journal bearings, supporting the input shafts and first-reduction pinions, are the tilt-pad type. Since these two elements are the interface between the MRG and the engines, they are susceptible to gear misalignment resulting from shaft motion and/or momentary minor misalignment caused by ship motion. The self-aligning feature of the tilt-pad bearing corrects for this misalignment. Additionally, the tilt-pad bearing will dampen incipient shaft whip. For more detailed information on the tilt-pad bearing,

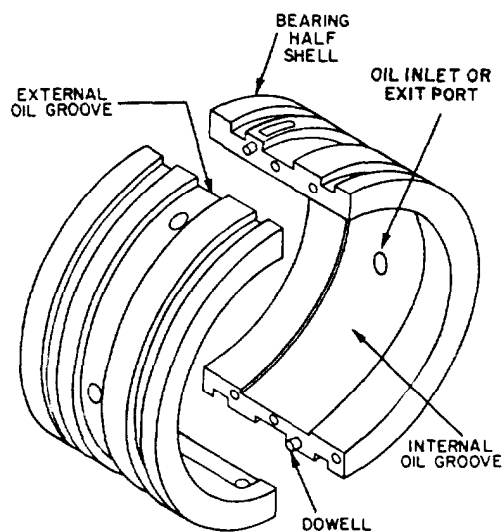

Figure 8-4.—Construction of a typical sleeve bearing.

refer to *Main Reduction Gear*, NAVSEA 0910-LP-045-9500.

All of the journal bearings are pressure lubricated from the MRG lube oil system. Lube oil is piped from the oil distribution header to each bearing. It then flows through a passage machined in the outside diameter of the bearing shells, into the drilled passage in the shell and lining, and to the bearing journal. A sight flow indicator is provided in the oil drain passage of each bearing to permit visual observation of oil flow. A dial-type, bimetallic thermometer and an RTE are installed in the sight flow indicator to provide

local and remote indication of the temperature of the oil leaving the bearings.

### Main Thrust Bearings

Propeller thrust is transferred from each propulsion shaft to the hull through a Kingsbury main thrust bearing (fig. 8-5). This bearing uses the lubrication principle of the wedge-shaped oil film; that is, an oil film between two sliding surfaces assumes a tapered depth with the thicker film at the entering side. In this assembly, eight bearing shoes are formed on each side of the

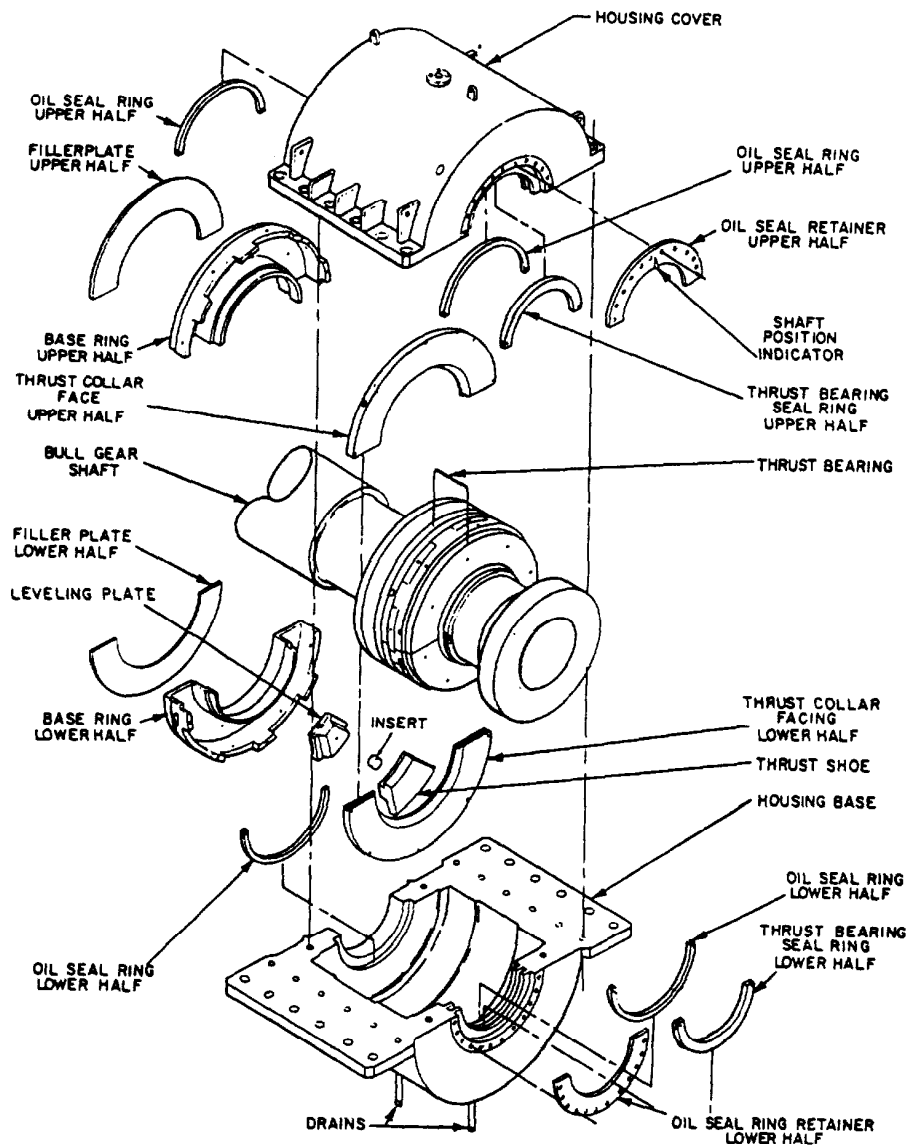

Figure 8-5.—Kingsbury main thrust bearing and housing.

thrust collar; therefore, eight separate wedge-shaped oil films are formed on each thrust face. Since the bearing shoes are free to tilt slightly, the oil automatically assumes the taper required by shaft speed, loading, and oil viscosity. One thrust shoe on each side is fitted with an RTE.

Thrust is transmitted from the rotating thrust collar to either (depending on ahead or astern propeller pitch) of the two stationary eight-shoe thrust rings. The rotating thrust collar is an integral part of the second-reduction (bull) gear.

Besides transmitting propeller thrust to the ship's hull, the main thrust bearing also positions the other elements in the gear train. Since double helical gear teeth inherently trail together in mesh, the limited axial clearance permits the main thrust bearing to locate all rotating elements in the casing space. This arrangement allows elimination of thrust bearings on the HS rotors with attendant reduction of maintenance and power loss. In operation, the LS gear is positioned by the main thrust bearing directly. The LS gear positions the four LS pinions through the gear mesh. The gear-type couplings on the lower intermediate assemblies are designed to position the lower HS gears through the quill shaft. The lower HS gears position the HS pinions and upper HS gears through the gear mesh.

#### **BRAKE/CLUTCH ASSEMBLY (DD AND DDG-993 CLASS SHIPS)**

Presently, two identical brake/clutch assemblies are mounted on each MRG assembly, one for each HS input shaft. These units will eventually be replaced by the SSS clutch used on the FFG and CG, and DDG-51 class ships. The brake and clutch in each assembly provide independent functions.

The brake is a pneumatically operated, multiple-disc type of brake. When applied, it locks the input shaft to prevent rotation of the GTE's power turbine rotor (turbine braking). The brakes may also be used to stop and prevent rotation of the propeller shaft. This can be accomplished only when both brakes are applied and both clutches are engaged. This process is called shaft braking and is controlled by the ECSS.

The clutch is a pneumatically operated, oil-cooled, forced-synchronization, combination friction and dental type of clutch. The multiple-disc friction element is used to bring the input shaft speed to within 11 rpm of the first-reduction pinion. The dental clutch then mechanically couples the input shaft with the pinion. When the dental clutch is engaged, all torque is transmitted

from the driving shaft to the driven shaft through the dental clutch. This engagement sequence is controlled by the control air system (COAS). Figure 8-6 shows the brake/clutch assembly.

#### **Control Air System**

Each brake/clutch assembly has one COAS unit mounted on each side of the MRG on the base flange below the lower second-reduction pinion. Each COAS unit contains all of the pneumatic and electronic components required for automatic control and monitoring of the brake/clutch assembly. Input requirements are 28-volt dc power from the propulsion local control console (PLCC) and 95 psig minimum control air pressure from the ship's service air system (SSAS).

The control components for each COAS unit have three solenoid air valve assemblies, two printed-circuit boards (PCBs) that control the operation of the valves, and two air-pressure regulators. The primary regulator is set at 100 psig to provide pressure for brake and clutch operation. The other regulator is set at 20 psig to provide a soft initial actuation of the brake.

The input parameters to the speed differential relay PCB are the input shaft and first-reduction pinion speed signals from magnetic speed pickups on the clutch housing. The speed differential relay controls the clutch engagement sequence. It inhibits friction clutch engagement if the clutch input and output shaft speed differential is greater than 1,500 rpm and inhibits the dental clutch engagement if the speed differential is greater than 11 rpm.

Both brake and clutch operation is inhibited (can be overridden by key switches in CCS) if the oil inlet temperature is greater than 130°F and oil inlet pressure is less than 14 psig. If control air pressure is less than 95 psig, brake and clutch operation is inhibited and cannot be overridden by the CCS. Brake and clutch status is indicated at the PACC and PLCC. A clutch cycle counter is also mounted in the COAS enclosure.

#### **Clutch Sequencing**

Magnetic speed pickups are mounted in the clutch housing and located directly over the teeth in the outside diameter of the sleeve gear and clutch cup. They produce electrical impulses proportional to the speed of the respective shafts. These signals are inputs to the electronics enclosure in the COAS for automatic sequencing of the clutch operation.

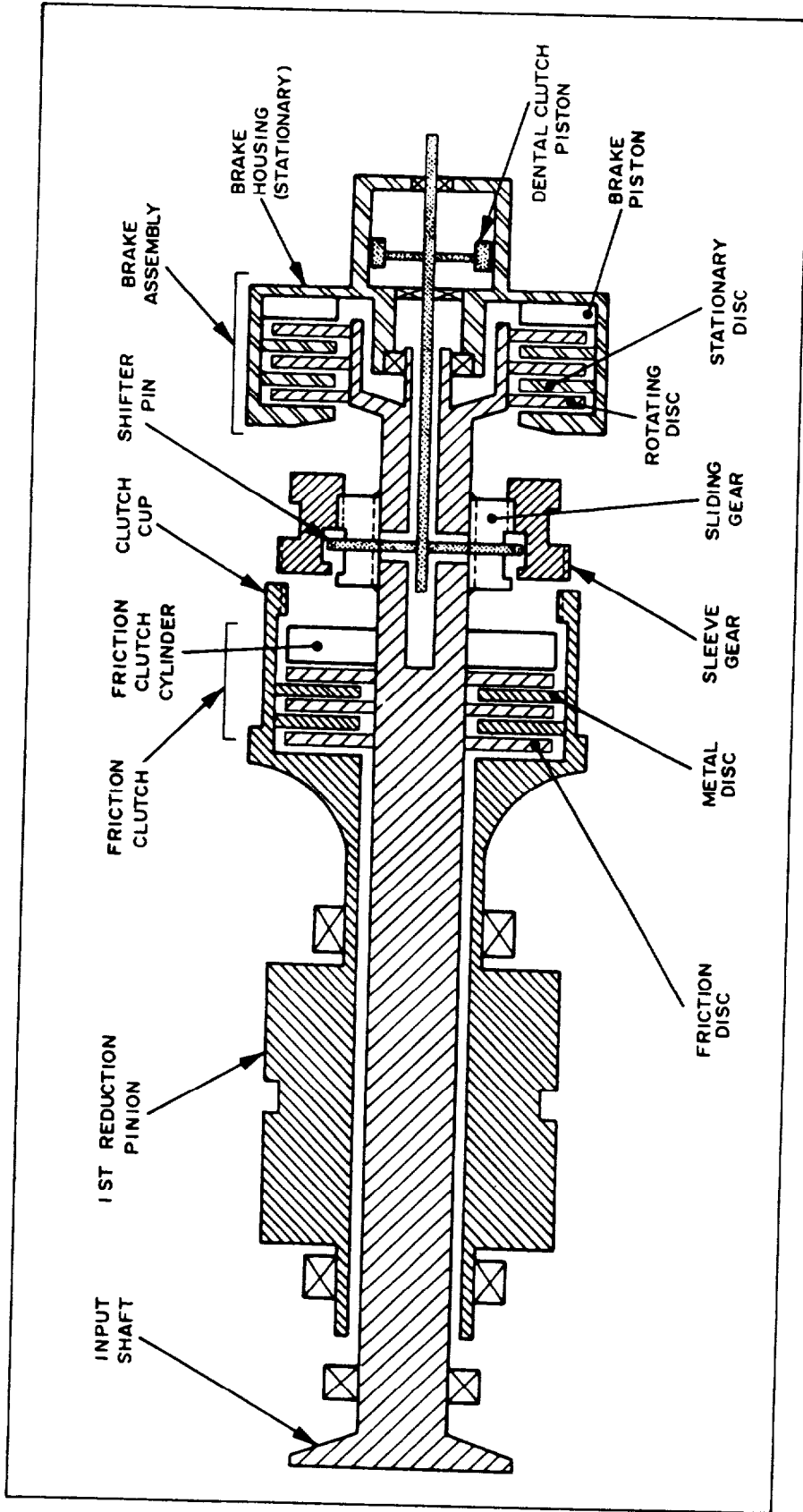

Figure 8-6.—Brake/clutch assembly—simplified.



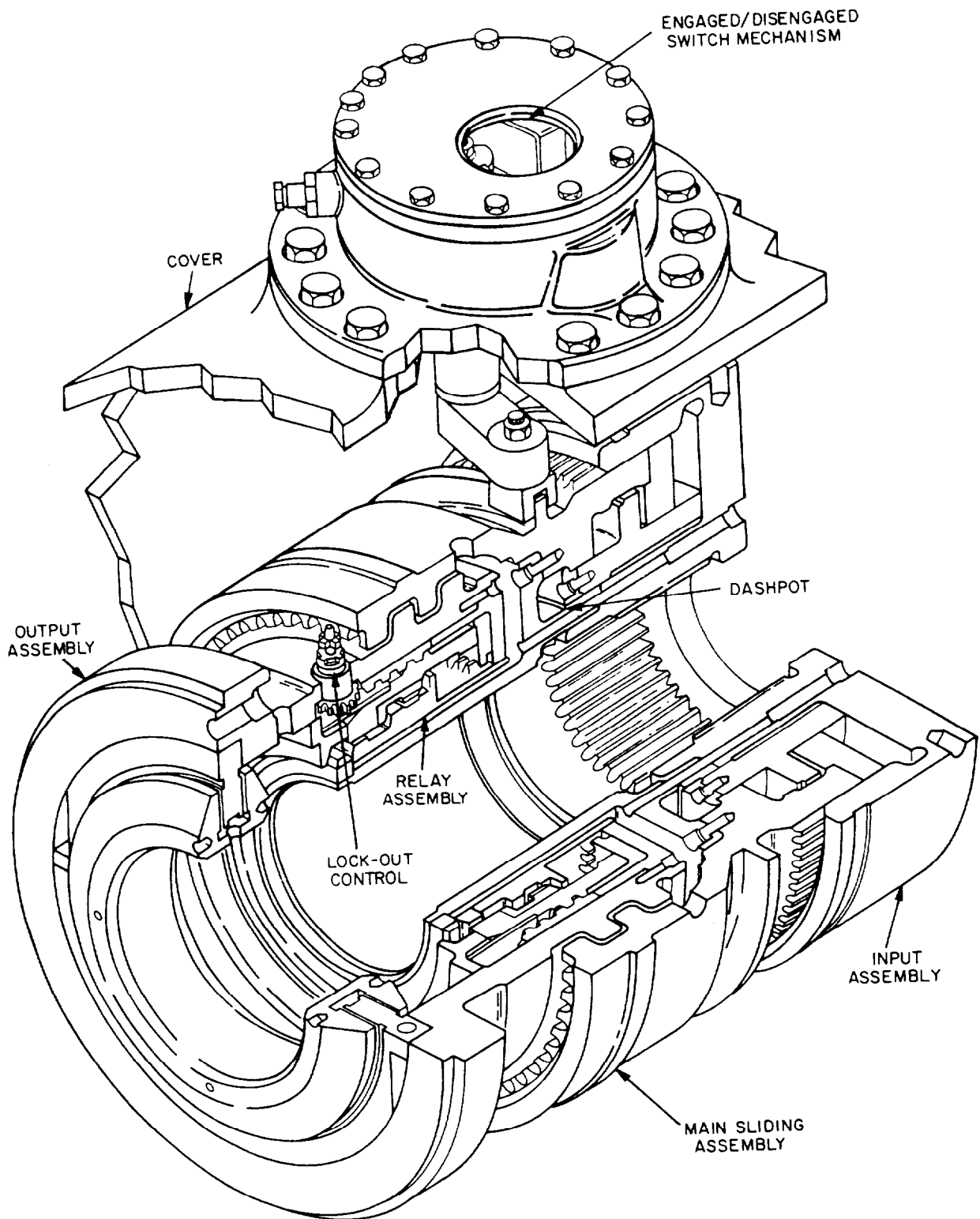

Figure 8-7.—SSS clutch assembly.

## SYNCHRO-SELF-SHIFTING CLUTCH

Identical positive drive SSS clutches connect the GTEs to the MRG power train. Each clutch is supported by the input shaft and the HS pinion couplings. The clutches permit operation with either one or both GTEs driving the propeller. They also permit changing GTE combinations while the MRG continues to rotate. The clutches are fully automatic, free-wheeling devices. They transmit torque (power) through splines and gear teeth machined in the clutch elements without external controls. Clutch engagement is initiated by a pawl and ratchet mechanism.

Figure 8-7 shows a clutch assembly. A manually operated lockout device prevents clutch engagement when actuated. The associated GTE can then be operated independently of the rest of the power train. An indicator/switch unit

mounted on the gear case transmits clutch status as ENGAGED/DISENGAGED to the control consoles. A hydraulic locking feature is provided in the design to prevent inadvertent clutch disengagement during normal transient or shock conditions. A local visual indicator indicates clutch status (ENGAGED or DISENGAGED). Two microswitches (situated in pairs for double-pole changeover action) are provided in each clutch to give remote indication of these positions. The clutch is lubricated from an oil supply shaft mounted in the HS pinion bore.

The SSS clutch has an input assembly, a main sliding assembly, a relay sliding assembly, and an output assembly. Figure 8-8 is a cross-sectional view of the clutch showing the primary components. The clutch also has a status indicator switch mechanism not indicated in figure 8-8.

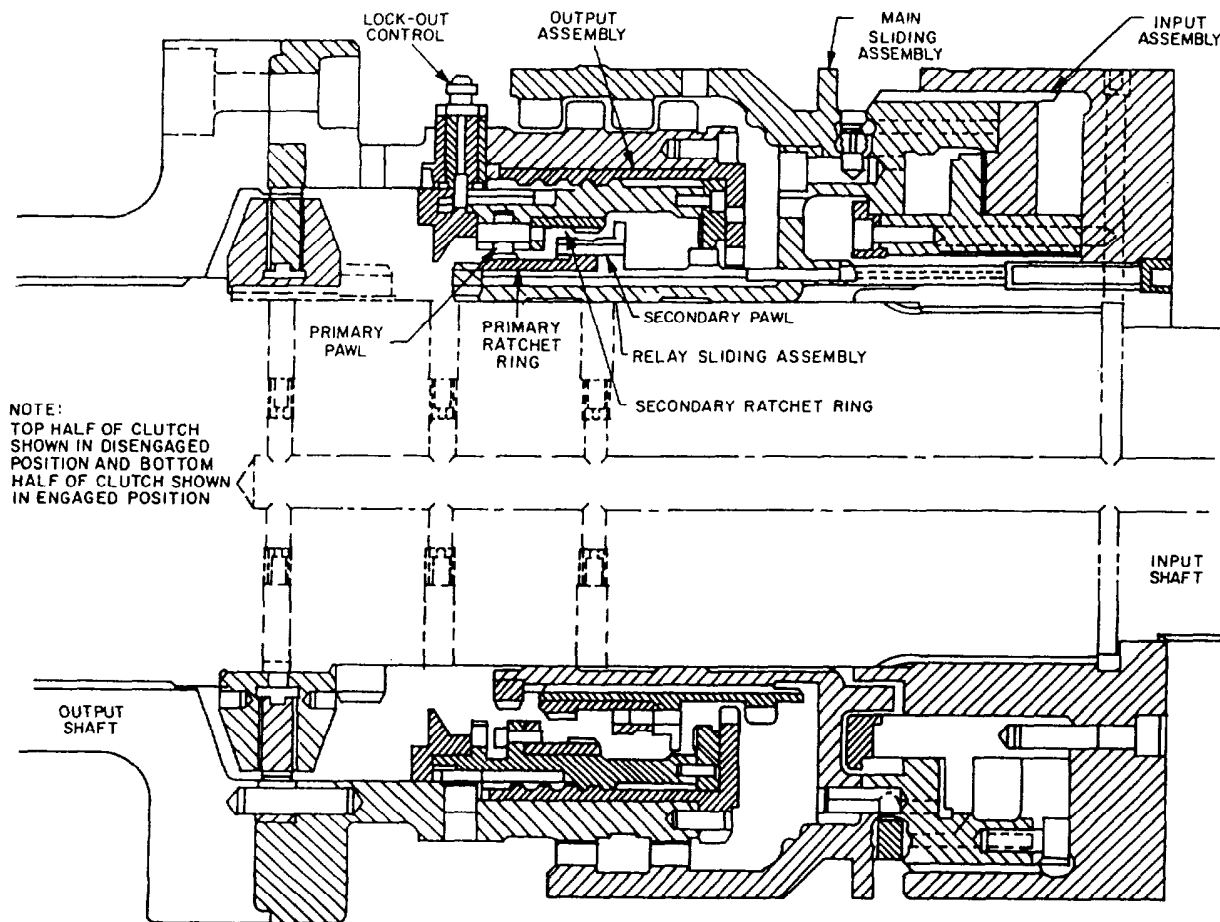

Figure 8-8.—SSS clutch (primary components).

## Clutch Engagement

The pawls and ratchet teeth are indexed to position the internal and external relay clutch teeth in line when the pawls engage the ratchet teeth. At this point, when the ratchet mechanism engages, a small axial force is developed. The relay sliding assembly is then forced to move axially along the helical spline to engage the relay clutch teeth. The load on the ratchet mechanism develops the small force required to shift the sliding relay. It is not subjected to the torque load in the main power train or to the force required to engage the main sliding assembly. The main sliding assembly is engaged by the relay sliding assembly. Two sets of pawls and ratchets (primary and secondary) are used to avoid continuous ratcheting when the clutch is overrunning (clutch disengaged and reduction gear rotating).

Four primary pawls are mounted on the output assembly and rotate with the HS pinion. The pawls are lightly spring-loaded to hold them inward to engage the external ratchet ring mounted on the sliding relay assembly. They are nose heavy. However, when the HS pinion speed exceeds approximately 500 rpm, centrifugal forces on the nose hold them out of contact with the primary ratchet. This prevents continuous ratcheting. As a result, these pawls are effective if the pinion speed is below 500 rpm (one-third idle speed). If the output assembly is rotating above 500 rpm (that is, the propeller shaft is being driven by the second gas turbine), the primary pawls are centrifugally disengaged; therefore, they can play no part in meshing the clutch. For this reason, the secondary pawls are provided. These pawls also line up with the relay clutch teeth at synchronism. From this point on, the clutch action is the same for whichever set of pawls is operating.

Four secondary pawls are provided to engage the clutch when the pinion speed is higher than 500 rpm. These pawls are mounted on the relay sliding assembly, which is driven by the GTE through the input and main sliding assemblies. These pawls are nose heavy; when the power turbine rotates, centrifugal force brings them into action with the secondary ratchet ring, which is a part of the clutch output assembly. When the output assembly is rotating at high speed and the input assembly is stationary or at low speed, the secondary pawls are held inward by a rim of oil formed centrifugally over the ratchet teeth; therefore, continuous ratcheting is prevented. When the power turbine accelerates, the relative

velocity between the oil rim and secondary pawls decreases and the centrifugal force on the nose of the pawls increases. When input speed reaches about half the output speed, the increased centrifugal force on the pawl noses starts a dampened ratcheting action. When input speed almost reaches output speed, the pawls ratchet fully in preparation to engage the relay clutch at synchronism.

An oil dashpot cushions the final movement of the main sliding assembly when the main clutch teeth approach full engagement. Figure 8-7 shows the position of the dashpot on the SSS clutch. The dashpot consists of a piston and cylinder formed by the flange of the support shaft and the bore of the main sliding assembly. While the relay clutch teeth are shifting the main sliding assembly, a large clearance exists around the dashpot piston. The clearance allows oil to be easily transferred from one side of the dashpot to the other. Just beyond the point in the clutch travel at which the relay clutch teeth unload, this clearance reduces. Oil is then forced through small orifices in the main sliding assembly. The dashpot thus cushions the final mesh of the clutch, but it does not impose high loads on the relay clutch mechanism. Because the dashpot is double acting, it also slows the disengagement rate.

## Clutch Disengagement

When a GTE is shut down and the clutch input assembly slows relative to the output assembly, a reverse torque is developed across the main helical spline. Continued reverse torque on the relay helical spline shifts the relay and the main sliding assembly to the fully disengaged position. Movement of the main sliding assembly actuates the clutch status indicator as the main clutch teeth disengage. During initial disengagement, the dashpot is active and disengagement is cushioned. The dashpot also tends to inhibit disengagement during transient conditions where sustained negative torque is not applied. The present design of the clutch is such that when a crashback maneuver is made (flank 3 to full astern), the clutch will automatically disengage for a period of about 6 seconds. This is caused by the shaft overrunning the power turbine speed.

## Lockout Control

The manually operated lockout control permits operation of a GTE without rotation of the MRG. Figure 8-7 shows the position of the

lockout control on the SSS clutch. It prevents initiation of the clutch engagement sequence by displacing the pawls from respective ratchet rings. This mechanism is incorporated in the output assembly and consists of a bevel pinion meshed with an actuating ring (ring gear). A special tool is provided that unlocks and turns the pinion.

### **Lubrication**

Lube oil from the MRG lube oil supply header is supplied to the rotating parts of the clutch through the center of the HS pinion. The rotating parts of the clutch and the thrust bearings absorb end thrust between the input shaft and the output connection of the MRG. The parts and bearings are supplied with oil through the center of the input shaft. The oil then discharges radially outward through a third hole, while a fourth feed hole lubricates the relay sliding surface.

### **OIL DISTRIBUTION**

The main lube oil service system supplies lube oil to the MRG and accessories through the main lube oil header. The headers are located at the top of the gear case. Gear and pinion teeth are lubricated and cooled by spray nozzles arranged to direct oil across the full face width at the gear mesh. Oil flow to journal bearings and the main thrust bearing is controlled by orifice plates. The orifices are sized to allow sufficient oil flow for lubrication, but they restrict excessive flow if extreme bearing wear or bearing failure occurs. The orifice plates are installed at the flanged connection to each bearing, except in the case of the HS pinion and input shaft bearings. Orifice plugs are installed in the bearing seats in these locations. Each bearing is equipped with a sight flow indicator and a bimetallic thermometer for local monitoring of oil flow and bearing oil temperature. Nominal lube oil pressure is 15 psig. Minimum oil pressure at the hydraulically most remote bearing is 5 psig. All ship classes have the same basic lube oil service system. Again, we will cover them separately because of the differences in design and setup.

### **DD, DDG-993, and CC Lube Oil Systems**

The lube oil service system is a pressure feed system that delivers oil under pressure to the MRG header and to each lube oil storage and conditioning assembly (LOSCA). All oil returns to the supply reservoir (the MRG sump) to

complete the loop. The lube oil service system includes the following major components:

The lube oil sump

Two motor-driven lube oil service pumps

An attached (driven by the MRG) lube oil service pump

A lube oil cooler

A duplex lube oil filter

A lube oil unloading valve

A lube oil heater

Interconnecting piping to the lube oil fill and transfer system

The three pumps take suction from the lube oil sump through check valves. The check valves maintain the pump's prime and prevent reverse flow through a secured pump. The pumps supply oil under pressure to a common line, where the unloader valve returns oil in excess of demand to the sump. Oil from the common line flows to the lube oil cooler, where its temperature is reduced to approximately 120°F. From the cooler, oil flow is divided into two paths, one to supply the MRG and the other to supply the two LOSCA coolers. Oil to the MRG flows through the duplex lube oil filter into the MRG lube oil header. From the MRG header, oil is distributed to lubricate and cool the reduction gear components, the brake/clutch assemblies, and the thrust bearings. The oil then returns to the sump. Oil to each LOSCA passes through a pneumatically controlled (unloading) valve. This valve controls oil flow to the synthetic lube oil cooler to regulate temperature at the synthetic oil discharge. Service system lube oil from the LOSCAs join in a common line to return to the MRG sump.

Pressure regulation of the lube oil service system is accomplished by control of the unloader valve. The controller senses pressure at the inlet connection to the MRG oil header and regulates the unloader to maintain 15 psig minimum at the header inlet. During normal operation, the motor-driven pumps are controlled by the ECSS. They can be cycled by a controlled sequence to maintain adequate oil pressure at the MRG header inlet.

Correct temperature of the oil in the lube oil service system must be maintained. If the temperature of the oil in the lube oil service system is below 90°F, the oil must be heated prior to propulsion plant operation. A motor-driven lube oil service pump may be used to assist in the heating of the oil by circulating it through the lube oil heater. The purifier is isolated from the heater when this procedure is used. During this operation, a portion of the lube oil service pump discharge is diverted through the lube oil heater and returned to the MRG sump. The remaining service pump discharge oil is circulated around the service system in the normal flow path. This warms up the total system for plant operation.

**MAIN REDUCTION GEAR LUBE OIL SUMP.**—The MRG lube oil sump is located in the inner bottom beneath the MRG. The sump contains the supply of oil for the main lube oil service system. It collects and retains oil as it returns from the MRG, main thrust bearing, and propulsion turbine synthetic lube oil system coolers. The lube oil return from the MRG to the main sump consists of a convoluted flexible connection bolted between the MRG oil pan and the top of the sump. The normal operating capacity is 1,500 to 1,550 gallons, and the low operating level is 1,400 gallons. When the sump is filled to the operating level, the pump suction bellmouths will be submerged under all operating conditions. The sump is designed to allow free drainage of pockets formed by stiffeners inside the sump and to allow access for inspection and cleaning. Lube oil return drains are located as far as possible from suction bellmouths. The sump is equipped with a sludge pit located at the lowest point. It is also equipped with a liquid level transmitter, an RTE, pump and purifier suction connections, and oil return connections.

**PUMPS.**—Three positive-displacement lube oil pumps are installed in each engine room, two motor-driven and one attached to and driven by the MRG. The attached lube oil pump is engaged or disengaged by a lever attached to the pump coupling. These pumps supply lube oil to the MRG and cooling oil to the two LOSCAs for the propulsion gas turbines. The motor-driven pumps supply oil to the system when the propulsion shaft is stopped and augment the attached pump at low shaft speeds. When a lead pump has been selected, the motor-driven pumps are controlled by the ECSS pump logic as a function of pressure at the inlet to the MRG lube oil header. The output of

the attached pump is not controlled and is proportional to shaft speed. Primary system pressure regulation is accomplished by the unloader valve. When the ship's speed increases and the total pump output exceeds the regulating capacity of the unloader, MRG inlet pressure increases. The ECSS pump control logic then sequences the motor-driven pumps to change to a slower speed or to cut off to maintain pressure in the operating range. When the pump control logic has sequenced both motor-driven pumps to cut off, the attached pump supplies the total lube oil system requirements. A similar control sequence operates to maintain oil pressure when shaft speed decreases.

**Motor-Driven Lube Oil Service Pumps.**—Two identical lube oil service pumps are located in each engine room. Each pump assembly consists of a vertical-screw, positive-displacement pump that is flexibly coupled to a two-speed electric motor mounted on a common steel bracket. Resilient mounting is used between the bracket and the ship's structure. The pump is rated at 700 gpm at high speed and 250 gpm at low speed at a discharge pressure of 60 psig. The pumps take suction from the MRG sump through a common suction line and discharge to the lube oil service piping.

A mechanical seal is located in the top end cover to prevent leakage along the pump shaft. Provision is made for installation of ring packing above the seal. Packing should not be used unless there is a failure of the mechanical seal. Lubrication is provided by the lube oil being pumped. The mechanical seal is lubricated through a tube and needle valve connected to the discharge end of the pump.

The pumps may be controlled locally at their respective controllers. With the LOCAL-REMOTE selector switch in LOCAL, the STOP-SLOW-FAST selector switch is operative. With the LOCAL-REMOTE selector switch in the REMOTE position, control is transferred to the ECSS.

The inlet to the MRG lube oil header is provided with a pressure gauge, a thermometer, a pressure transducer, an RTD, and a pressure switch.

The pressure transducer signal provides a meter reading at the PACC and the PLCC, a HEADER PRESS HI/LO light and alarm at the PACC and the PLCC, and information for data logging. It also provides a high-low signal for alarm logging and provides information to the

pump control logic at the PLCC for use in controlling the number of pumps in service and pump speeds.

The RTD provides a signal to the ECSS for the following uses:

1. Meter reading of header temperature at the PACC and the PLCC
2. HEADER TEMPERATURE HI/LO indicator light and audible alarm at the PACC and the PLCC
3. Alarm logging

The pressure switch provides the permissive for the MRG turning gear.

**Attached Lube Oil Pump.**—The attached lube oil pump is of a similar design to the motor-driven pumps. The principal difference is in the larger size and greater rated capacity. The attached pump is rated at 1,140 gpm at 60 psig discharge pressure and 1,220 rpm (approximately 168 shaft rpm).

The attached pump is supported by a bracket immediately above the lube oil sump top. It is driven by the MRG lower inboard second-reduction pinion shaft through a right-angle drive. The angle drive is equipped with a manually operated disconnect device that may be used to disconnect the attached pump when the main shaft is stopped. The attached pump takes suction from the sump through an individual suction line and discharges into the lube oil service piping system. The pump speed is proportional to shaft speed; therefore, the attached pump does not deliver enough oil by itself to lubricate the MRG and to cool the GTE synthetic oil until higher shaft speeds are reached.

**LUBE OIL COOLER.**—A lube oil cooler is installed in each lube oil service system downstream from the lube oil pumps to maintain the oil outlet temperature at 120°F. The cooler consists of a shell assembly, a tube bundle, and inlet and outlet water boxes.

The cooler is a single-pass shell and tube type of heat exchanger. Seawater is used as the cooling medium. It enters the inlet water box through the inlet connection, makes one pass through the tubes, and is discharged through the outlet water box. Seawater flow is regulated by a pneumatically operated valve controlled by a temperature sensor installed in the lube oil piping downstream from the cooler. The lube oil

inlet is at the opposite end from the water inlet, resulting in counterflow heat transfer.

**LUBE OIL FILTER.**—A duplex filter is installed in the piping downstream from the lube oil cooler to remove particulate matter from the lube oil. The filter consists of a single cast steel body mounted on a fabricated steel base. The filter body contains two filter chambers and a diverting valve assembly. The diverting valve connects the filter chambers to the inlet and outlet ports. The filter chambers are covered by bolted steel plates.

A manually operated changeover assembly positions the diverting valve to place the right or left filter element in service. The selector lever is positioned over the chamber selected. A hydraulic interlock prevents the shifting of oil flow to an open (nonpressurized) filter chamber. An interlock cylinder is connected to each of the filter chambers. When a differential pressure exists between the chambers, the cylinders engage a notch in the diverting valve cam plate and positively lock the selector lever. The changeover assembly also contains a balancing valve that is used to equalize pressure between the chambers to allow shifting. The assembly also fills the filter chamber after cleaning. Each filter chamber is provided with a vent and a drain.

The liftout filter elements are constructed of pleated wire cloth, supported by inner and outer perforated metal tubes. Magnets supported inside each filter element remove ferrous particles from the oil.

A differential pressure gauge and switch are connected to the inlet and outlet flanges for local and remote monitoring. The differential pressure switch opens at 10 psid and sends a signal to the ECSS. The ECSS activates the STRAINER DP HI light and alarm at the PACC and the PLCC, and provides data for alarm logging.

**UNLOADING VALVE.**—An unloading valve is located between the main lube oil header and the MRG sump. It is controlled by a pressure sensor located at the MRG oil inlet. It is set to maintain reduction gear inlet oil pressure at 15 psig minimum under steady state conditions.

**LUBE OIL HEATER.**—One lube oil heater is installed in each engine room. The heater has connections to the purifier and to the lube oil service piping system. The heater is used to heat the oil during purification and to heat oil during lube oil service system warm-up.

Heaters are of conventional shell and U-tube design. Each heater is designed to raise the oil temperature from 40°F to 90°F at 30 gpm and to 160°F at 4 gpm.

Oil enters at one end of the shell and makes one pass through the heater as directed by the baffles. Ship's service steam enters one end of the tubes through the inlet connection and makes one pass through the U tubes. Condensate is returned to the condensate collecting system through the contaminated drain inspection tank. The steam inlet valve is controlled by a temperature sensor located in the oil outlet.

A temperature switch, sensing the oil temperature at the heater outlet, opens at 170°F and provides a signal for the ECSS. It is used to operate HEATER TEMP HI alarm lights at the PACC and the PLCC and for alarm logging.

### **FFG Lube Oil System**

The reduction gear lube oil service system supplies oil to the propulsion reduction gear and clutches for lubrication and cooling. The oil supply also circulates through heat exchangers and acts as a coolant for the GTE lube oil service system.

The reduction gear lube oil service system is a closed loop system with the sump tank vented to the atmosphere. Circulation of lube oil is normally accomplished by one service pump with the other service pump on automatic standby. A third pump that is pneumatically driven acts as a standby to the two service pumps and provides an oil supply to the reduction gear in case of electrical power failure on the ship. The system is initially filled by the lube oil fill, transfer, and purifying system.

The reduction gear lube oil service system includes the following components:

- Lube oil service pumps (2)
- Lube oil coast-down pump
- Lube oil unloading valve
- Lube oil temperature-regulating valve

Lube oil cooler

Lube oil discharge filter

Lube oil sump tank

**LUBE OIL SERVICE PUMPS.**—The pumps are two-speed, electric-motor-driven, vertically mounted, screw-type pumps. The controls allow either pump to be designated NORMAL with the other designated as STANDBY. The normal pump runs at low speed only for preheating the lube oil and runs at high speed during service conditions. With the pump controller mode switch in the AUTO position, operation of the pumps is controlled by a set of pressure switches. If the oil pressure to the reduction gear hydraulically most remote bearing begins to drop below 13 psig, a pressure switch closes and causes the standby pump to start operating at low speed. If the oil pressure continues to drop below 11 psig, another pressure switch closes and the standby pump switches to high speed. A further drop in pressure to 9 psig closes a third pressure switch. It also causes the pneumatically driven, coast-down pump to start operating by opening the solenoid valve to the pump's air motor.

When the oil temperature is below 90°F, preheating is required. A connection to the lube oil fill, transfer, and purifying system allows use of one of the lube oil service pumps to circulate oil through the lube oil purifier heater. Priming lines are provided at each pump so the operation of either service pump will maintain a continuous oil prime to the other two pumps. A relief valve set at 80 psig is located at each service pump discharge to protect the system from overpressurization.

**LUBE OIL COAST-DOWN PUMP.**—This pump is a pneumatically driven, vertically mounted, screw-type pump. If the propeller shaft is rotating during an electric power failure on the ship, the service pumps stop. The loss of pressure causes the lube oil coast-down pump to start and continue to run until the propulsion plant can be secured. The duration of operation of this pump is limited by the quantity of air stored in the HP air flasks provided in the engine room. The discharge of the coast-down pump goes into the reduction gear oil inlet header via the lube oil service filter. The discharge bypasses the rest of the lube oil service system. A relief valve set at

80 psig protects the discharge piping from over-pressurization. If the service pumps restore normal system pressure to 15 psig, a pressure switch opens and the air solenoid valve that controls airflow to the pump motor closes and stops the coast-down pump. The coast-down pump also stops if the propulsion shaft comes to a stop.

**LUBE OIL UNLOADING VALVE.**—The air-pilot-operated valve senses the oil pressure at the reduction gear's hydraulically most remote bearing and regulates the oil supply flow to maintain 15 psig at that bearing. If the sensed pressure exceeds 15 psig, the valve will open and return excess system flow to the lube oil sump tank. The valve is fully open at a sensed pressure of 20 psig. Control air from the ship's LP vital air main is used for the operation of this valve.

**LUBE OIL TEMPERATURE-REGULATING VALVE.**—The air-pilot-operated valve is located at the inlet to the lube oil cooler and regulates the amount of oil flow through the cooler. The temperature-sensing element is mounted in the oil supply piping to the reduction gear. Based on the signal from the temperature sensor, the valve regulates the amount of flow through the cooler and bypasses the rest. The valve is set to maintain a  $110 \pm 5$  °F oil temperature to the reduction gear. Control air from the ship's LP vital air main is used for operation of this valve.

**LUBE OIL COOLER.**—This cooler is made of two shell and tube type of heat exchangers piped in series. Seawater from the main seawater cooling system circulates through the tubes in a single pass through each shell of the cooler in series. The lube oil flows through each shell in series. The oil enters the cooler through the upper shell and leaves the cooler through the lower shell. Vent connections are provided on both the upper shell and water box, and drain connections are provided on the lower shell and water box.

**LUBE OIL DISCHARGE FILTER.**—This filter consists of two separate filter housings connected by interlocked inlet and outlet valves arranged so that only one housing is in operation at a time. Each filter housing contains 14 filter

elements rated at 65 microns. The filter elements can be cleaned and reused. Vent and drain connections are provided for each filter housing.

**LUBE OIL SUMP TANK.**—The sump tank is located below the propulsion reduction gear and is attached to the gear drain pan by an expansion joint. The tank capacity at the normal oil level is 1,400 gallons. The two service pumps and the coast-down pump each have an independent suction tail pipe from the tank.

Spent oil returns to the sump through an opening around the bull gear cover. Main ship's structural members in the tank act to smooth the turbulence in the oil return area. The pump suction is located away from the turbulent area so that the oil is permitted to deaerate before entering the suction.

## ATTACHED EQUIPMENT

The attached equipment, as we mentioned earlier in this chapter, consists of the turning gear motor assembly, the attached lube oil and CRP pumps, the electrostatic vent fog precipitator, the dehumidifier, the shaft tachometer, the revolution counter and elapsed time indicator, the MRG instrumentation, the turbine brakes, and the propeller shaft brakes.

With the exception of the MRG turning gear, all of the attached equipment is similar between the DD, DDG-993, CG, and FFG class ships.

### Turning Gear Motor Assembly

The turning gear motor assembly is mounted on the aft end of the port HS pinion. It is primarily used to rotate the entire reduction gear train for inspection and maintenance purposes. It can also be used on some ships to lock the main shaft.

**DD AND DDG-993 CLASS SHIPS.**—The turning gear is an electric-motor-driven, double-reduction gear mounted on the upper casing of the MRG. When engaged and operating, it rotates the propulsion shaft at approximately 0.1 rpm. The turning gear drives the upper outboard second-reduction pinion through a manually operated engagement sleeve. A



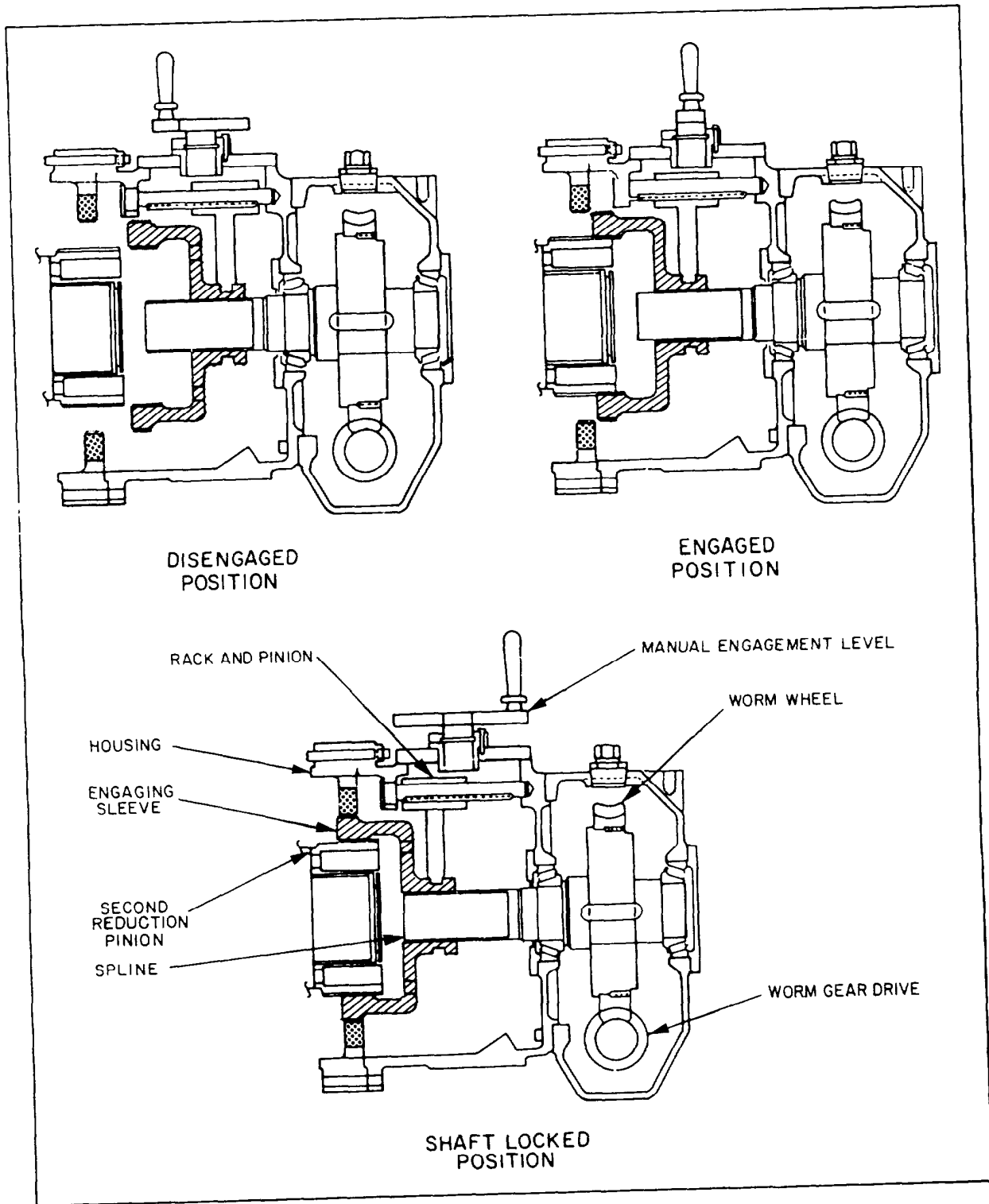

Figure 8-9.—Turning gear mechanism (DD and DDG class ships).

three-position lever selects one of three positions-ENGAGED, DISENGAGED, or SHAFT LOCKED. Figure 8-9 shows cross-sectional views of the turning gear mechanism in all three positions. In the disengaged position, the handle can be padlocked to a bracket to prevent accidental movement of the operating lever. Do not attempt to engage the turning gear while the reduction gear is operating. Also, do not attempt to operate the turning gear with the operating lever in the shaft locked position. Either of these actions will result in equipment or personnel casualties. With the turning gear engaged, the gear may be rotated manually with a wrench. A limit switch assembly provides electrical signals for TURN GEAR ENGAGED and SHAFT LOCKED indicators at the PACC and the PLCC and a disengaged signal for the ECSS logic. The MRG lube oil header must have 15 psig of pressure to operate the turning gear motor.

The drive motor for the turning gear is a 440-volt, 3-phase, 60-hertz electric motor, rated 5 horsepower (hp) at 1,200 rpm. It drives the turning gear drive shaft through a worm gear. The turning gear assembly is lubricated by oil sprays from the MRG lube oil supply header and a self-contained oil sump.

**CG CLASS SHIPS.**—An electric-motor-driven, double-reduction turning gear assembly is mounted on each MRG (fig. 8-10). When engaged, the turning gear drives through the upper outboard second-reduction pinion. The assembly consists of a 7.5-hp-driven motor and a double-reduction, spiroid/worm-type speed reducer. The turning gear assembly is attached to the MRG through the second-reduction housing flange and the shaft lock ring (stop gear). A flexible coupling attaches the drive motor shaft to the spiroid pinion in the first-reduction housing. A coupling guard covers the flexible coupling. All bearings in the turning gear assembly are antifriction bearings. Lubrication is accomplished by a combination oil immersion and spray system supplied from the MRG lube oil system at a rate of 3 gpm. The splined gears are spray-lubricated; the worm gears are lubricated by gear meshes and bearings dipping into a self-contained reservoir.

Two shifting levers are provided with the turning gear. The shaft lock shifting lever is mounted on top of the unit and is used to lock the shaft adapter to the shaft lock ring. The other lever, the turning gear shifting lever, is mounted on the back of the turning gear assembly and is

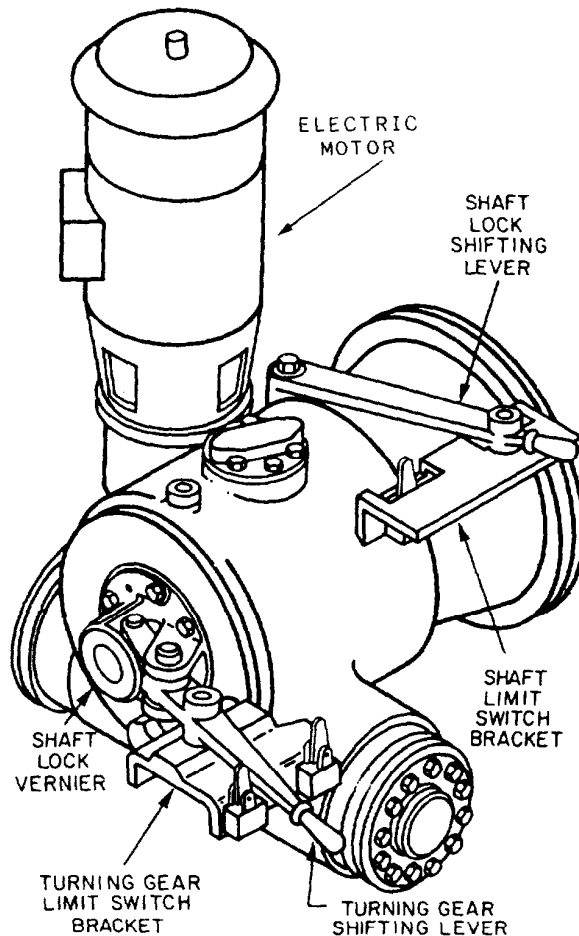

Figure 8-10.—Turning gear assembly (CC class ships).

used to engage and disengage the turning gear clutch.

The shaft lock shifting lever moves the shaft lock clutch with a shifting yoke. An index plate, mounted on the housing, and an indicator plate, mounted on the worm shaft, make up a turning gear shaft lock vernier. This vernier indicates when shaft lock male clutch teeth are in line with the female clutch teeth attached to the turning gear housing. The shaft lock shifting lever locks the shaft lock movable male clutch teeth to the stationary female clutch teeth attached to the turning gear housing. Plates on the gear lock limit switch bracket identify two positions of the shaft lock shifting lever: SHAFT UNLOCKED and SHAFT LOCKED. The vernier indicator is used to align the clutch teeth, while an open-end wrench is used to rotate the shaft during mating of the teeth. Limit switches send signals to the

ECSS to indicate the status of the shifting lever. Override stops are provided on the clutch and shaft lock limit switch brackets to prevent the shifting levers from moving past the microswitch positions.

The turning gear shifting lever is connected to the turning gear clutch via the clutch shaft. Shifting this lever can engage or disengage the clutch from the shaft adapter. The shifting levers can be padlocked to the disengaged positions to prevent accidental engagement of the turning gear while the MRG is operating. Two plates on the clutch limit switch bracket identify the shifting lever position: TURNING GEAR DISENGAGED and TURNING GEAR ENGAGED. The connect-disconnect coupling moves in the axial direction to engage or disengage. The shifting lever axially engages or disengages the internal gear teeth with mating teeth on the end of the second-reduction pinion shaft.

The turning gear provides a means for rotating the propeller shaft while the propulsion plant is shut down. The second-reduction gear shaft and propeller shaft rotate at about 0.1 rpm with the turning gear engaged and operating. This slow speed permits inspection of the MRG gear teeth. The slow rpm also permits MRG cooldown without shaft distortion or bending. Turning also prevents propeller shaft bowing. The circuit permissives which must be satisfied to engage the turning gear are as follows:

- Shaft not locked
- Greater than 9 psig lube oil pressure
- No GTE running
- No clutch engaged (Turning gear motor cannot be engaged if either clutch is engaged.)

**FFG CLASS SHIPS.**—Figure 8-11 shows the turning gear assembly on the FFG class ships. It is mounted on the aft end of the port HS pinion. It has a shift lever for engagement or disengagement. Two microswitches associated with the shift lever provide electrical signals to the propulsion control console (PCC) and the local operating panel (LOP) when the shift lever is engaged or disengaged.

The turning gear assembly includes a 5-hp electric motor that operates from a 440-volt, 60-hertz, 3-phase power source. The coupling between the electric motor and the turning gear train includes a mechanically operated brake. This brake is used to lock the turning gear and may also be used to lock the entire reduction gear train.

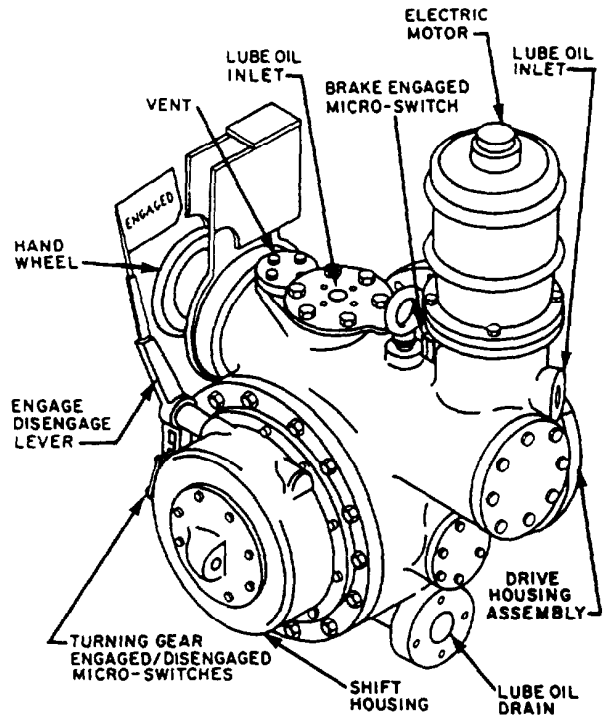

Figure 8-11.—Turning gear assembly (FFG class ships).

When the turning gear is locked, a microswitch that is actuated by the brake lever provides a brake locked signal to the PCC. A handwheel is also provided for turning the turning gear manually. The gearbox for the turning gear has a worm gear drive system.

The electric motor is controlled by a magnetic controller that is mounted remotely from the MRG. The motor is designed to operate in either the forward or reverse direction.

### Lubricating Pump

The lube oil system in each MER incorporates three positive-displacement pumps. Two of the pumps are driven by electric motors, while the third is driven by the MRG and is designated the attached pump. The purpose of the attached pump is to augment the output of the electric pumps during propulsion plant operation. This pump is a vertical-screw, submerged-suction pump, with a nominal flow of 1,140 gpm at 1,220 rpm pump speed. The motor-driven pumps are of similar construction, but they have a smaller capacity.

The attached pump is driven by the lower inboard second-reduction pinion shaft through a manually operated connect/disconnect coupling and a right-angle drive unit. Figure 8-12 shows this right-angle drive.

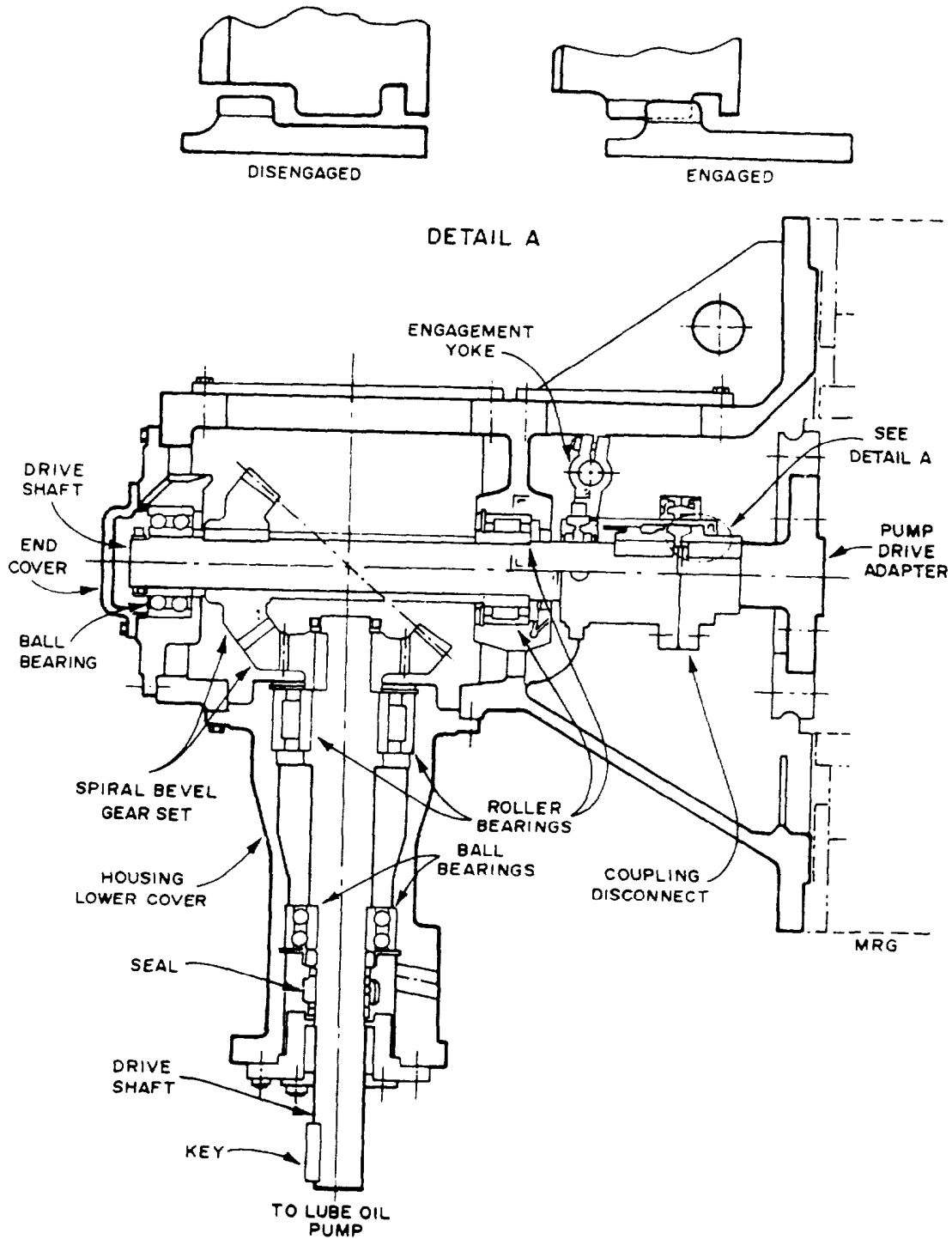

Figure 8-12.—Attached lube oil pump drive.

The coupling has two sleeve gears and a sliding gear. One sleeve gear is keyed to the pump drive adapter on the second-reduction shaft and the other is keyed to the horizontal drive shaft of the drive unit. The sliding gear is splined to the sleeve

gear on the horizontal drive shaft. A yoke fits around the sliding gear, and the engagement lever is attached to the yoke. When the engagement lever is moved to the engage position, the yoke moves the sliding gear axially on the drive shaft

sleeve gear coupling and engages the sliding gear with the sleeve on the pinion shaft. The engagement lever position is marked on a plate on the drive housing under the lever handle. The handle can be locked in either the ENGAGED or DISENGAGED position (see detail A on fig. 8-12). No remote status indication is provided. A photoengraved plate should be visible, adjacent to the unit, with the following caution message:

### CAUTION

Do not attempt to engage or disengage the manually operated attached lube oil pump drive coupling while the reduction gear is in operation.

This action will result in equipment or personnel casualties. However, you can disconnect the pump drive couplings while the MRG is in operation if an emergency occurs.

The drive unit has a drive assembly housing, a horizontal drive shaft, a spiral bevel gear set, and a vertical drive shaft. The horizontal shaft drives the vertical drive shaft through the set of spiral bevel gears. The vertical drive shaft drives the attached pump through an extension shaft. The extension shaft is attached to the pump and the drive unit through flexible couplings. The pump drive and disconnect coupling unit is lubricated by sprays from the MRG lube oil system. The vertical couplings are grease-lubricated.

### Controllable Reversible Pitch Hydraulic Pump

The backup hydraulic oil pump for the CRP propeller is attached to the MRG. It is driven by the lower outboard second-reduction pinion through a manually operated, connect/disconnect type of coupling and spiral bevel gear right-angle drive assembly. The coupling/drive unit is similar to the coupling drive unit for the attached lube oil pump. The main difference is that the horizontal bevel gear on the coupling/drive unit is mounted on the MRG side of the vertical bevel gear to give opposite rotation to the output shaft. The output shaft is coupled to the pump through a flexible coupling. The attached CRP hydraulic oil pump is similar to the hydraulic oil power module (HOPM) motor-driven pump, which we will discuss further along in this chapter. During normal operations, **NEVER** attempt to engage or

disengage the manually operated attached CRP hydraulic oil pump coupling while the reduction gear is in operation. However, you can disconnect the pump drive couplings while the MRG is in operation if an emergency occurs.

### Electrostatic Vent Fog Precipitator

The electrostatic vent fog precipitator is mounted in the lube oil system vent piping. The purpose of the vent fog (mist) precipitator is to remove entrained oil mist from the MRG vent air before it is discharged into the engine room. The mist precipitator is a two-stage, electrostatic type, capable of removing 95 percent of the entrained oil from the vent air at an airflow rate of 10 cfm. It has a charging element (ionizing section), a collecting element (collecting section), and an integral power supply. The power supply converts the input voltage, which is 120-volt, single-phase, 60-hertz, to 10,000-volt dc.

Figure 8-13 shows the operating principle of the vent fog precipitator. In operation, the MRG vent air enters the precipitator through a flame arrestor mounted in the inlet plenum. The oil particles in the vent air are electrically charged (positively,) as they pass through an ionizing section. In the ionizing section, a high concentration of ions emanate from the ionizer electrode suspended in the center of and at the entrance to the collector tube. The ionizer electrode is charged with high-voltage dc and the collector tube is electrically grounded.

The positively charged oil particles then pass into an electrical field set up within the collector tube. The field is created by a positive, high dc voltage being applied between the high-voltage tube and the collector tube. The positively charged oil particles are attracted and adhere to the wall of the negative (grounded) collector tube. As more particles collect on the collector tube wall, they form an oil film, which runs down the wall into the inlet plenum. From the inlet plenum, the oil drains into the MRG. The cleaned vent air is discharged into the engine room.

The air discharged from the precipitator originates primarily from changes in operating conditions that cause temperature changes in the MRG. Expansion and contraction of the oil and air inside the MRG result in air being aspirated into the gear case. Other possible sources of aspiration of air are moving HP and LP areas inside the case (caused by rotation of the gears), which result in aspiration of air, gasket and seal leaks, and strainer changing.

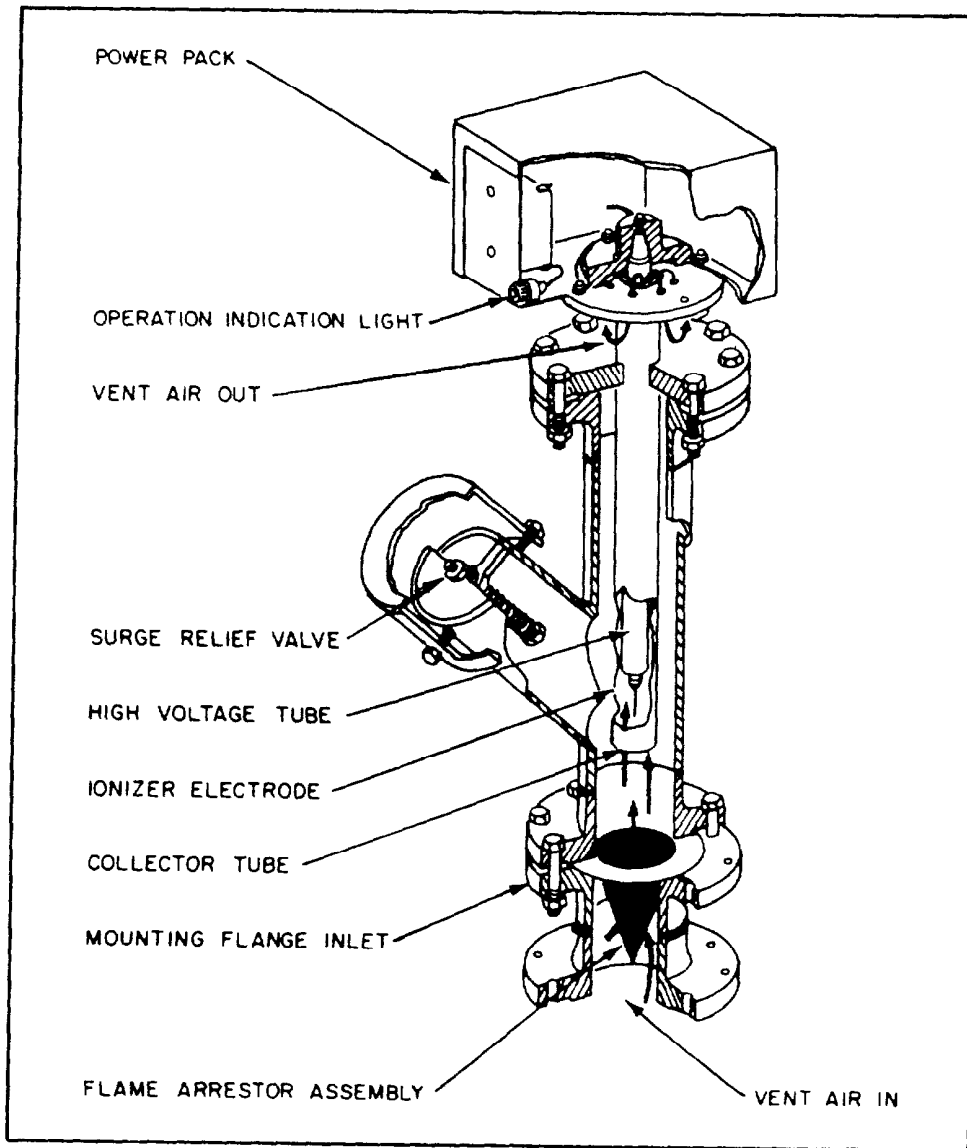

Figure 8-13.—Vent fog precipitator.

### Dehumidifier

Many gas turbine ships now have a dehumidifier permanently installed on each MRG. The purpose of the dehumidifier is to maintain the air within the MRG casing at less than 35 percent relative humidity when the MRG lube oil system is secured. The dehumidifier is not normally operated while the ship is underway. Detailed procedures for operating and maintaining dehumidifiers are furnished by the manufacturers' technical manuals, PMS, and the EOSS. Carefully follow these written procedures

when you are operating or performing maintenance on dehumidifiers.

### Shaft Tachometer

Each MRG has two tachometer generators to provide an electrical signal for remote indication of propulsion shaft speed. The generators are driven off the upper inboard second-reduction pinion shaft. The drive assembly consists of a drive housing, a drive adapter, a drive ring, and a gear train with three quill shafts. The drive adapter and drive ring are connected to the

second-reduction pinion. The gear train pinion is driven by the drive ring and in turn drives the three spur gears. Two of the spur gear drive the two tachometer generators through quill shafts (the third gear drives the revolution counter and elapsed time indicator).

The output signal from each tachometer generator consists of voltage pulses generated at the rate of 512 pulses for each propeller shaft revolution. The signal voltage and pulse width are determined by the rotational speed of the tachometer drive assembly. The tachometer signals pass through separate amplifiers located on the MRG casing near the tachometer enclosure. After being amplified and converted to 256 pulses per shaft revolution, the tachometer signals enter the signal conditioning enclosure (S/CE). Comparison circuitry, within the S/CE selects the strongest tachometer signal and sends it on to the rest of the ECSS for logging and display of shaft speed. The tachometer (quill) shaft must be turning at least 30 rpm for a reliable reading.

### DANGER

**Do not attempt to work on the tachometer system while it is in the automatic propulsion mode. A loss of signal from the tachometer could cause an undesirable or dangerous propulsion plant response.**

#### Revolution Counter and Elapsed Time Indicator

The revolution counter is mounted adjacent to the tachometer generators and is driven by the same drive assembly. The unit provides a local, digital display of total propulsion shaft revolutions and elapsed time at specific shaft speed ranges. Figure 8-14 shows the face of the unit.

#### Tachometer Generator, Revolution Counter, and Magnetic Speed Sensor Drive

On the FFG class ships, the tachometer generator, revolution counter, and magnetic speed sensor drive are driven by the starboard HS

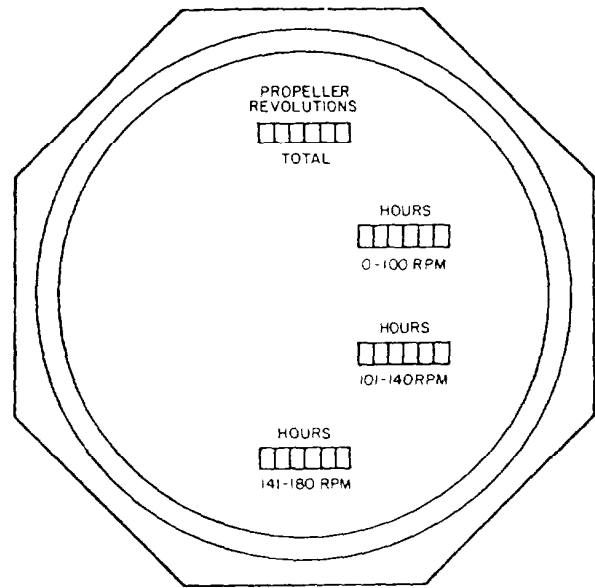

Figure 8-14.—Revolution counter and elapsed time indicator.

pinion. It contains provisions for connecting a tachometer generator, a revolution counter, and a magnetic speed sensor. The tachometer generator and revolution counter are driven at exactly 50 percent of the propeller shaft speed.

#### MRG Instrumentation

A liquid sight indicator (fig. 8-15) is provided at each main bearing. Each indicator has a fitting containing a window (bull's eye) through which a stream of oil can be observed flowing from the bearing, a fitting for a dial-type thermometer, and a well for installation of a remote-reading RTE.

Lube oil pressure at the inlet to the header is sensed by both a pressure transducer and a pressure switch. The transducer sends signals to the ECSS for METER/DDI display, pump logic operation, data logging, and HEADER PRESS HI/LO alarming at the PACC and the PLCC. The pressure switch provides the permissives for the turning gear and GTE starting.

The most remote bearing lube oil pressure is sensed by a transducer located at the lower

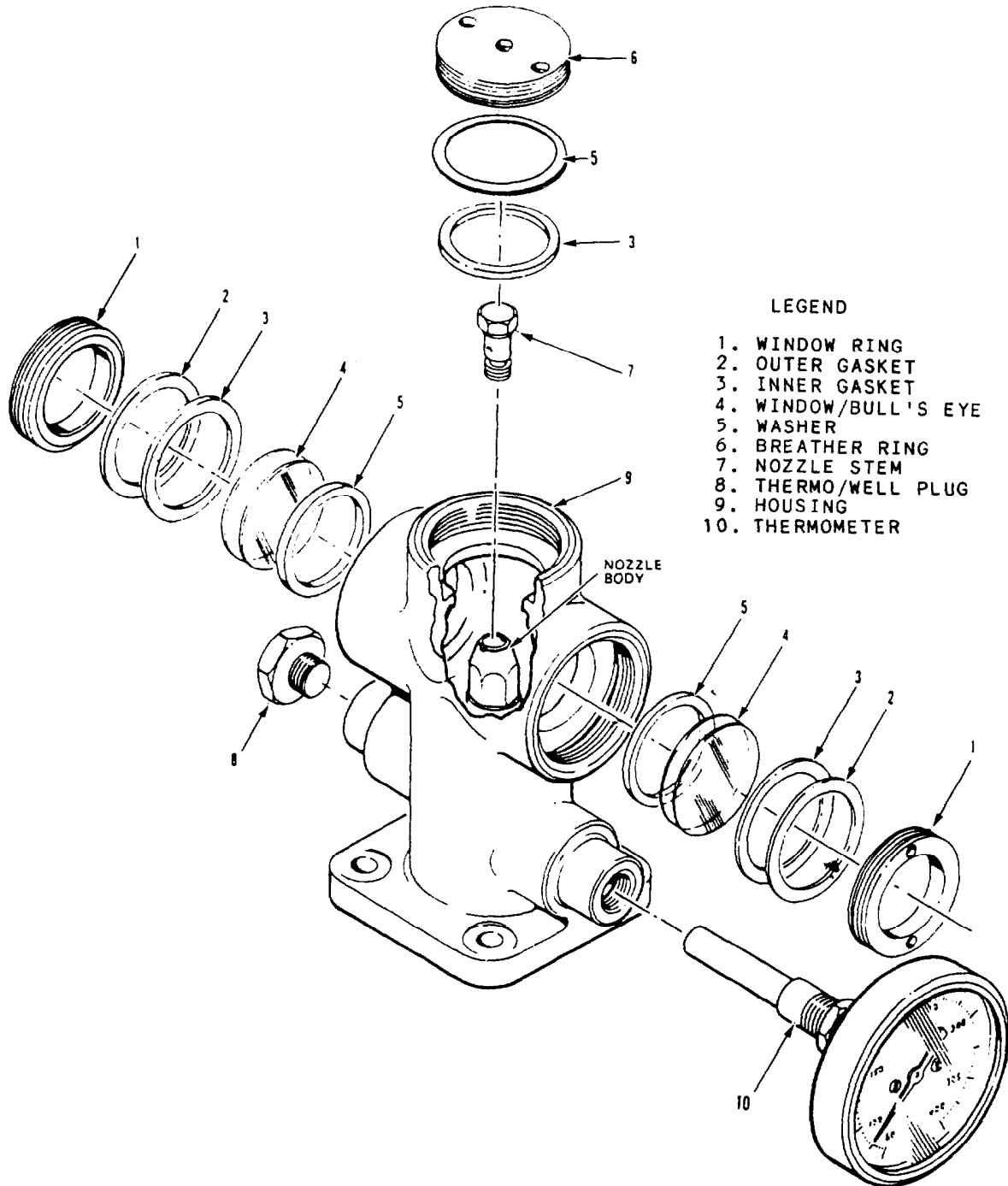

Figure 8.15.—Liquid sight indicator.

outboard first-reduction gear (forward port-aft starboard) bearing.

A temperature switch, located in the brake/clutch oil inlet, is set to open contacts at 130°F to prevent brake/clutch operation. A temperature-sensitive bellows actuates a switch

to open or close electrical contacts at the set point.

A temperature transducer, located at the inlet to the header, provides both meter display and HEADER TEMP HI/LO alarm at the PACC and the PLCC.



## FFG Turbine Brakes

Each input shaft is equipped with a single disc caliper brake assembly. Figure 8-16 shows a typical turbine brake assembly. Each brake is pneumatically operated and is self-retracting. The brake includes two brake pads, one on each side of the brake disc. Since the brakes are

self-adjusting, they always maintain the proper clearance.

The brakes are controlled by individual solenoid valves in the turbine brake panel so they may be engaged independently of each other. The solenoid valves are controlled electrically at the PCC and the LOP. The valves may be actuated manually at the turbine brake panel (fig. 8-17).

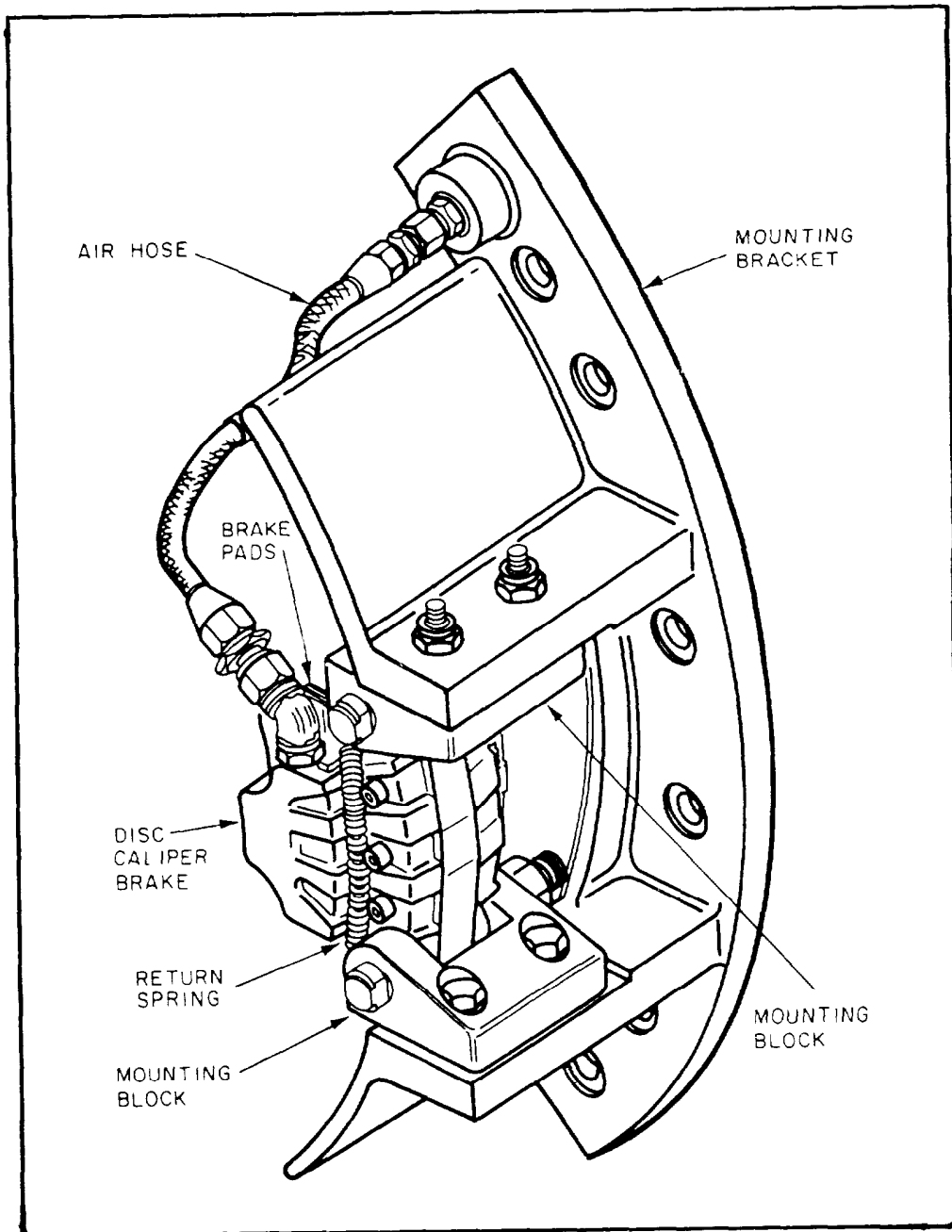

Figure 8-16.—Typical turbine brake assembly.

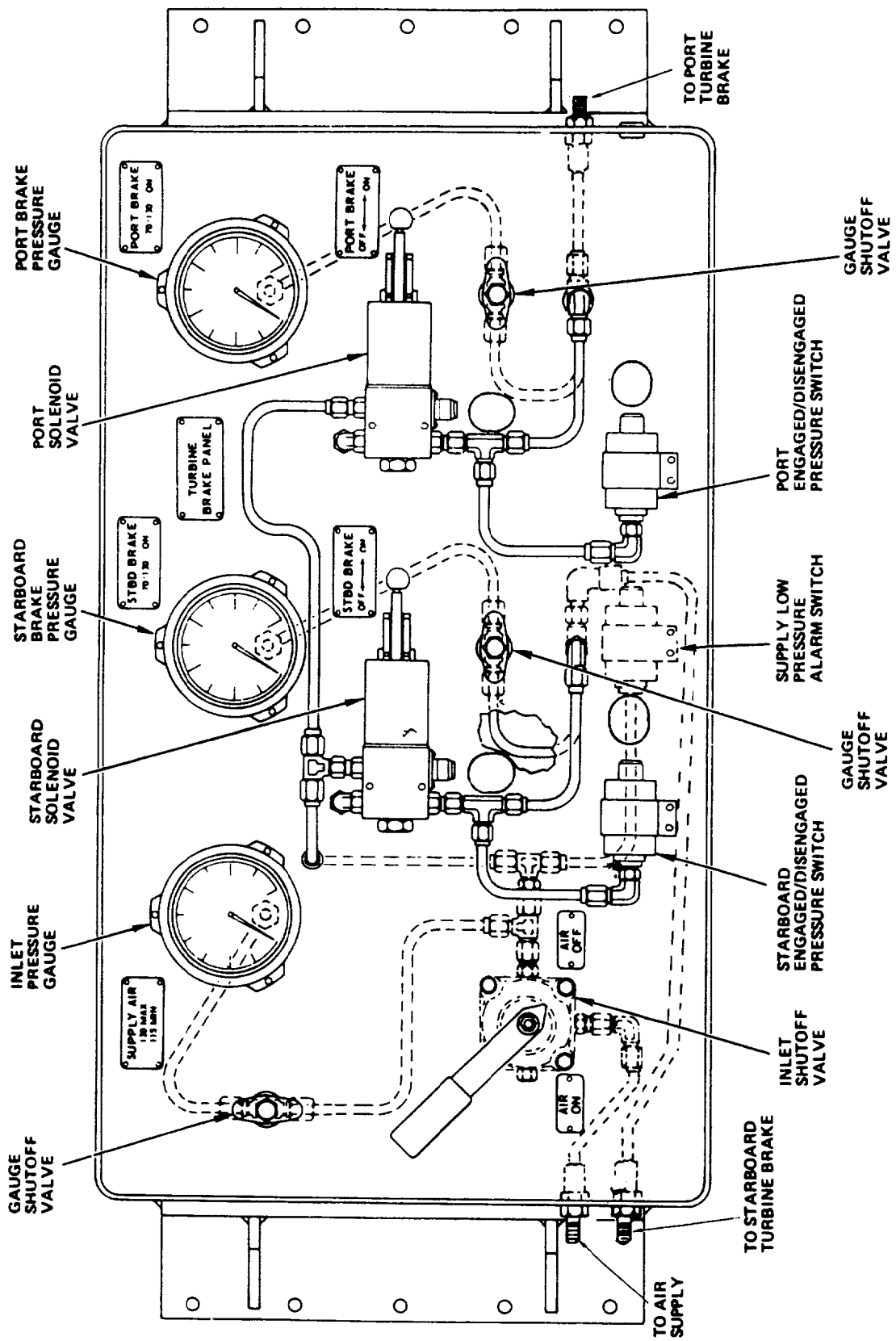

Figure 8-17.—Turbine brake panel.

A pressure switch associated with each solenoid control valve provides an electrical signal when the brake is engaged. A low-pressure alarm switch is also provided in the turbine brake panel to provide an electrical signal whenever the input air pressure drops below 70 psi. Normal operating pressure is between 70 to 125 psi. An air receiver at the inlet to the turbine brake panel maintains a constant volume for brake engagement.

### Shaft Brakes

A propeller shaft brake assembly (fig. 8-18) is mounted on each starboard first-reduction quill shaft. Each brake assembly has three disc caliper brakes. The disc caliper brakes are pneumatically operated and are self-retracting. Each brake includes two brake pads, one on each side of the

brake disc. Since the brakes are self-adjusting, they always maintain the proper clearance.

Both brake assemblies are controlled by a single solenoid valve in the propeller shaft brake panel (fig. 8-19). The solenoid valve is controlled electrically at the PCC, the LOP, or the SCC. The valve may be actuated manually at the propeller shaft brake panel. A pressure switch associated with the solenoid valve provides an electrical signal when the brakes are engaged. A low-pressure alarm switch is also provided in the propeller shaft brake panel. The alarm switch provides an electrical signal whenever the input air pressure drops below 1,150 psi. Normal operating pressure is 1,250 psi reduced down from 3,000 psi. An air receiver at the inlet to the propeller shaft brake panel maintains a constant volume for brake engagement.

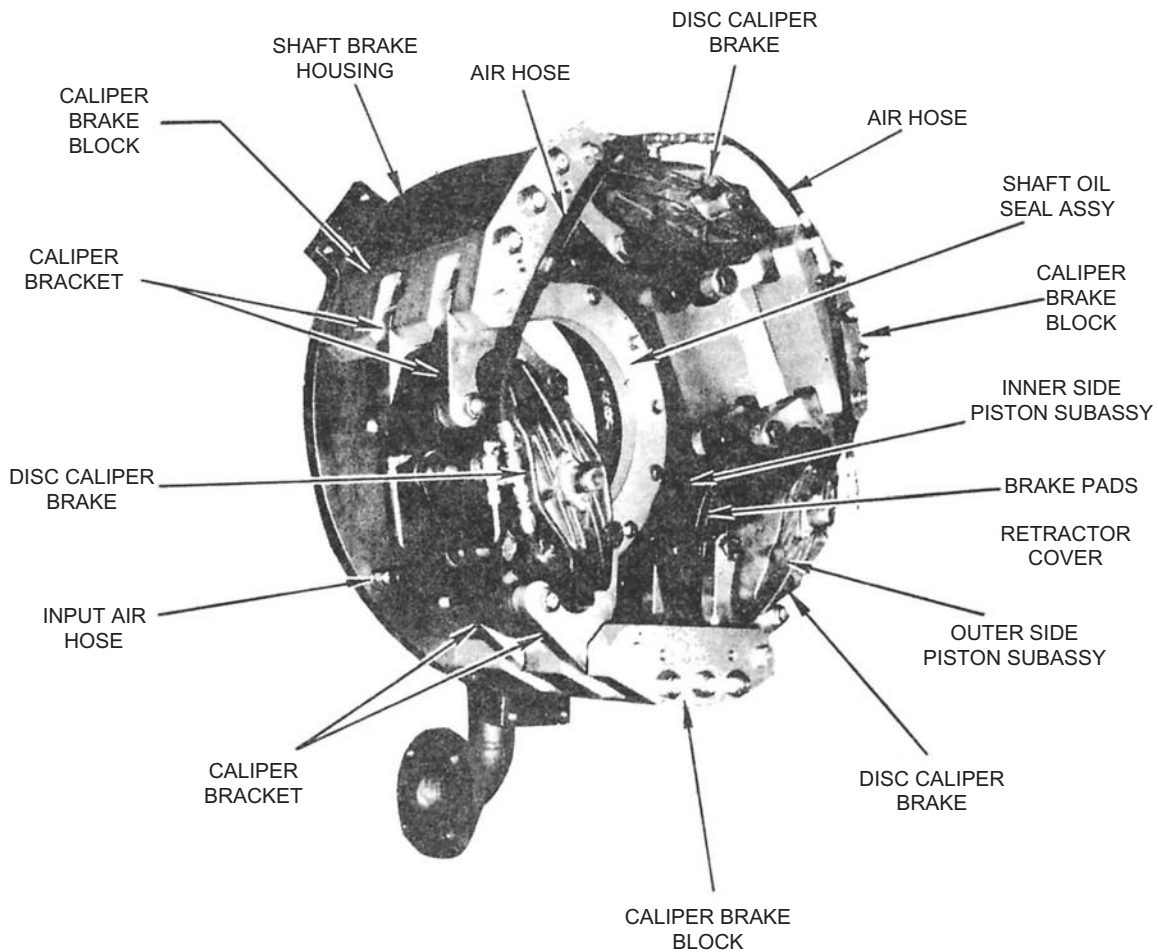

Figure 8-18.—Typical propeller shaft brake assembly.



An air filter (shown on fig. 8-1) is provided at the output of the propeller shaft brake panel to provide constant filtering of the air applied to the propeller shaft brakes. This air filter contains a replaceable element.

### CONTROLLABLE PITCH PROPELLER SYSTEMS

The ship's propulsive thrust is provided by a hydraulically actuated propeller or propellers, depending on the class of ship. Each propeller is driven by two GTEs through a reduction gear assembly and line shaft as previously described. Since the GTEs cannot be reversed, the CRP propellers provide both ahead and astern thrust, thus eliminating the need for a reversing gear. The following description of the CRP system is based on the DD-963 class ships; systems on the DDG-993 and CG-47 class ships are basically the same as the controllable pitch propeller (CPP) system on the FFG class ships. For a more thorough description of your ship's system, check the shipboard technical manuals and ship's information books.

The CRP propeller system for the propulsion shaft consists of the propeller blades and hub assembly, the propulsion shafting, hydraulic and pneumatic piping and the control rod contained in the shaft, the HOPM, the OD box, the control valve manifold block, the electrohydraulic controls, the hydraulic oil sump tank, and the head tank. Figure 8-20 shows a block diagram of the system.

The CRP propeller has five blades. The blade pitch control hydraulic servomotor, mechanical linkage, and hydraulic oil regulating valve are housed in the propeller hub/blade assembly. High-pressure hydraulic control oil is provided for each propeller by the HOPM that is located adjacent to the reduction gear. An OD box, mounted on the forward end of the reduction gear, is mechanically connected to the hydraulic oil regulating valve by a valve control rod. The OD box contains the hydraulic servomechanism that positions the regulating valve rod. The OD box also provides the flow path connection between the hub servomotor and the HOPM. The regulating valve control rod, PA piping, and the flow path for the hydraulic oil supply and return are contained in the hollow propulsion shafting.

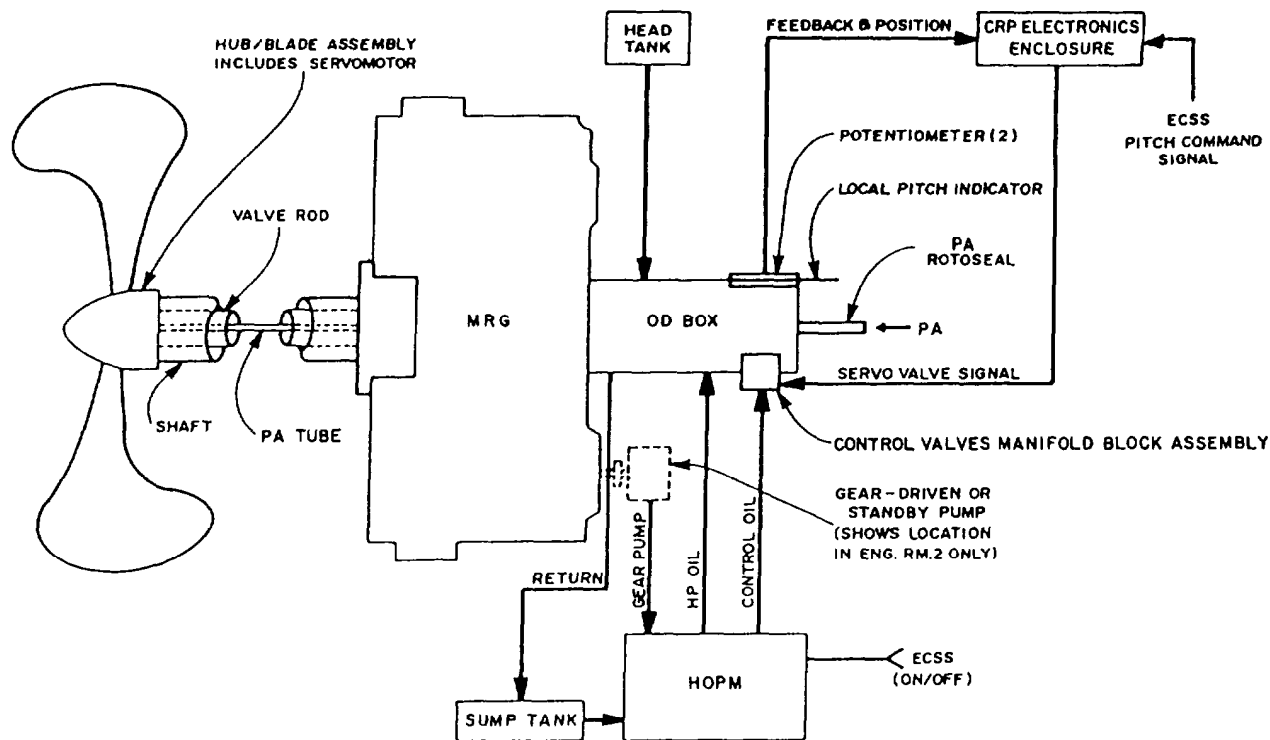

Figure 8-20.—CRP propeller system block diagram.

A control valves manifold block assembly, mounted on the side of the OD box, contains control valves for both manual and automatic (electronic) pitch control. The manual control valves consist of a manual pitch control valve and two manual changeover valves. Automatic pitch control is accomplished through an electrohydraulic control oil servo valve. This valve responds to an electrical signal generated from the shipboard electronics.

### HUB/BLADE ASSEMBLY

The hub/blade assembly provides the mounting for the five propeller blades and contains the hydraulic servomotor mechanism for blade pitch control. It also transforms propulsion shaft rotational torque into axial thrust for ship propulsion. The hub body is secured to the tailshaft flange by 15 bolts and 5 dowel pins. The rotational torque of the propulsion shaft is transmitted to the hub by the five dowel pins. The hub/blade assembly has the following major components (fig. 8-21):

- Hub body assembly
- Piston and piston rod assembly
- Crosshead and sliding blocks

- Regulating valve
- Blades and blade bolts
- Crankpin rings
- Blade seal base rings
- Tailshaft spigot
- Blade port covers
- Hub cone cover and hub cone end cover

### Hub Body Assembly

Propeller blade pitch is hydraulically controlled by the hydraulic servomotor. The servomotor, consisting of the piston, the piston rod assembly, and the regulating valve, is contained within the hub body. A one-piece crosshead is secured to the forward end of the piston rod. The hub body forms the crosshead chamber with the tailshaft spigot enclosing the forward end of the chamber and the hub body end plate enclosing the aft end. The servomotor cylinder is formed by the hub body end plate and the hub cone. The piston rod extends through the bore in the hub body end plate into the crosshead chamber.

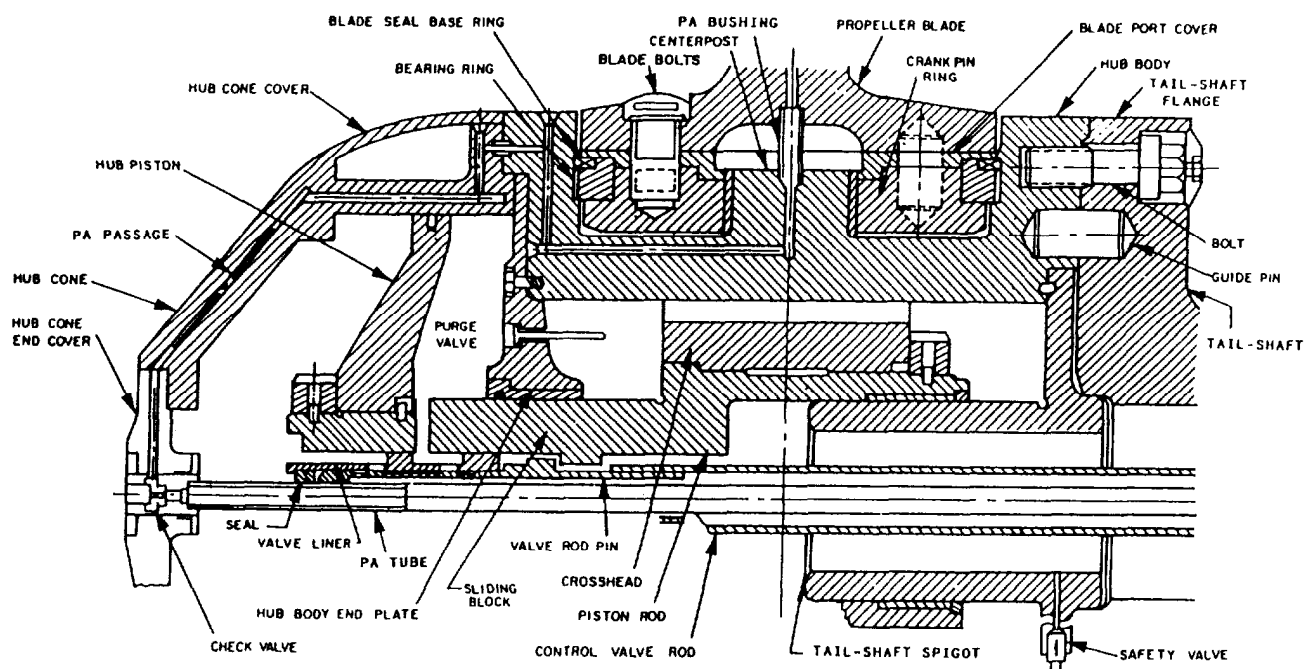

Figure 8-21.—Cross-sectional view of the hub/blade assembly.

Five sliding blocks fit into slots machined in the crosshead. The hub body contains five blade ports with a center post in each port. The center posts are integral parts of the hub body. A crankpin ring fits over the center post in the blade ports. An eccentric crankpin on the underside of each crankpin ring fits into a hole in each sliding block. When the servomotor piston is translated as a result of differential pressure across the piston, axial movement of the crosshead produces rotary movement of the crankpin rings through the sliding blocks and eccentric crankpins. The propeller blades, which are secured to the crankpin rings, arc thus rotated, resulting in the desired pitch change.

Figure 8-22 shows the hub assembly regulating valve, consisting of a valve liner and a valve pin, which controls the position of the servomotor piston. The valve liner is secured in the piston rod bore. Ports in the forward and aft ends of the liner provide a flow path for hydraulic power oil to the forward and aft chambers of the servomotor cylinder. The valve pin fits inside the valve liner and moves axially within the liner. The amount of axial travel of the pin in the liner (1/2 inch total) is limited by a machined shoulder on the piston rod bore. The valve pin contains hydraulic power oil ports in the forward and aft ends and return oil ports centered between. Axial movement of the valve pin is controlled by the valve rod connected to the valve pin at the aft end and to the OD box at the forward end.

When the valve rod is moved in the forward direction, the aft hydraulic power oil ports in the valve pin align with the aft ports in the valve liner; the return oil ports in the valve pin align with the forward ports in the valve liner; and the forward ports in the valve pin are blocked off. Thus, hydraulic power oil at 200 to 600 psig is directed to the aft chamber of the servomotor cylinder. The forward chamber of the cylinder is open through the return oil ports. The resultant pressure differential across the servomotor piston causes the piston to move forward. This results in a change of blade pitch in the ahead thrust direction. During pitch translation, the piston rod, valve, and valve rod move together. Pitch translation continues until movement of the valve rod stops and the valve pin is centered in the valve liner. When the valve rod is moved in the aft direction, the action is reversed, resulting in pitch change in the astern direction.

When the valve pin is centered in the liner, both ports in the liner are blocked off. However, reliefs machined in the valve pin lands permit a

continuous flow of hydraulic power oil to both sides of the servo piston. The continuous flow results in a balanced pressure across the piston, holding the blade pitch constant. In this position, hydraulic pressure on both sides of the piston is sufficient to hold the desired blade pitch regardless of changes of blade thrust loading.

The flow path for the hydraulic power oil is from the OD box through two drilled passages in the regulating valve rod, through the valve rod, and into the hollow valve pin. The oil returns through the valve pin return ports, which are continuously indexed to slots in the valve liner. It then flows into the chamber formed by the outside diameter of the valve rod and inside diameter of the propeller shaft and to the OD box. A PA tube runs through the regulating valve rod and valve pin from the OD box to the cone end cover.

### **Blades**

Each propeller has five blades. The blades are made of nickel bronze alloy and weigh 4,300 pounds each. Each blade is attached to a crankpin ring with eight bolts. A machined air channel runs along the blade leading edge from the root to the blade tip. This channel provides the flow path for PA, which discharges through small orifices located along the leading edge. Prairie air is delivered to the blades through the PA tube that runs through the regulating valve rod from the OD box to the hub cone. Drilled passages in the hub cone and hub body to the blade base completes the flow path. A check valve in the hub cone prevents seawater from entering the PA system when air is not flowing.

### **Blade Seal Base Ring**

A blade seal base ring is located under the outer edge of each blade port cover. The purpose of the seal base ring is to prevent oil from leaking out of the hub and seawater from leaking into the hub. Each seal base ring has two O-rings. One provides the seal between the seal base ring and the blade port cover; the other provides the seal between the seal base ring and the hub body. Eighteen compression springs under the seal base ring provide positive loading of the ring against the blade port cover.

### **Tail-shaft Spigot**

The tail-shaft spigot has the physical appearance of a short shaft with a flange on one

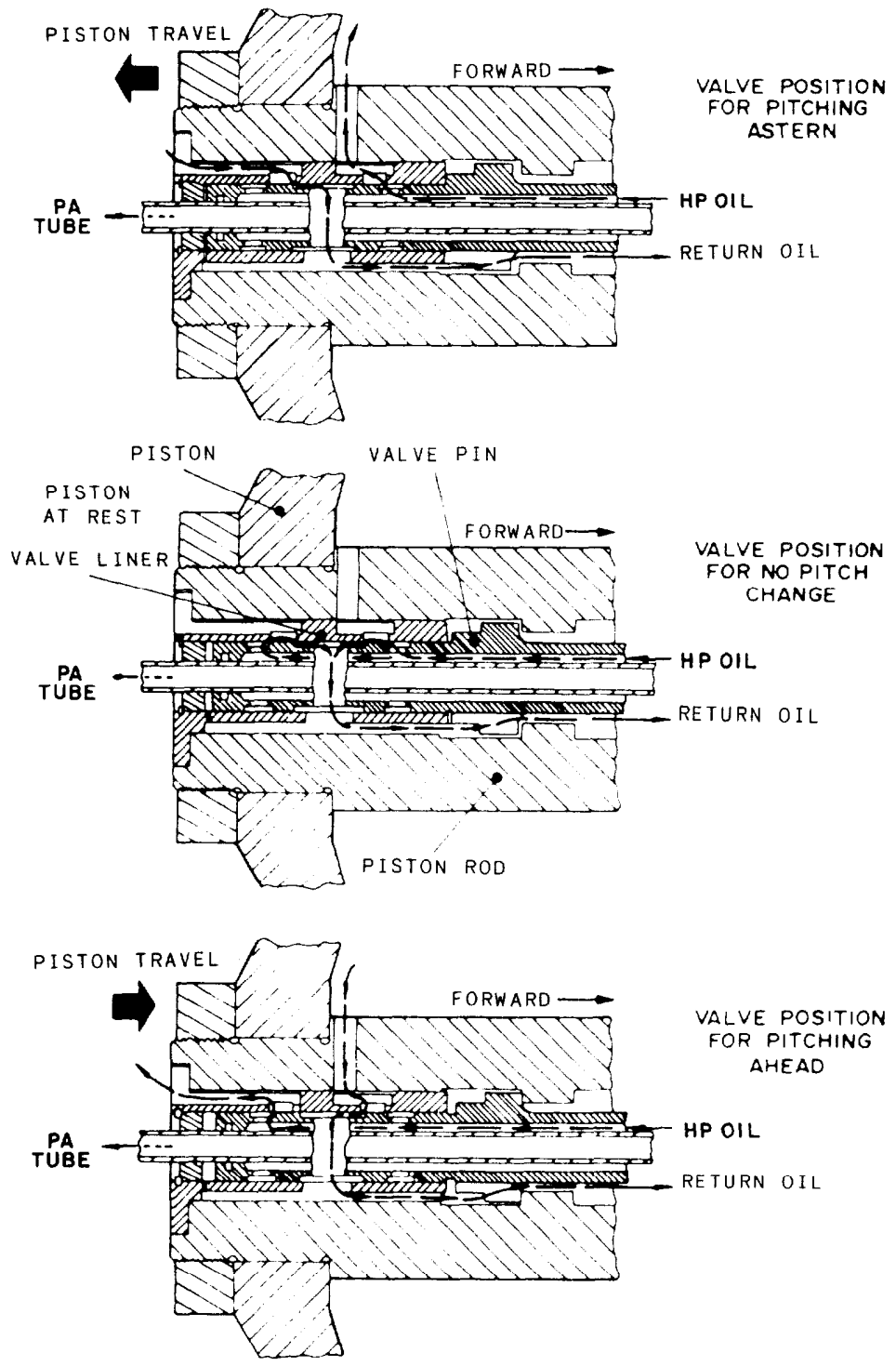

Figure 89-22.—Hub assembly regulating valve.



end. It is bolted to the forward end of the hub body concentric with tail shaft. The tail-shaft spigot, with the shaft portion extending into the crosshead chamber, encloses the forward end of the chamber. The shaft portion of the spigot is the same diameter as the piston rod. It serves as a guide and support for the piston rod and crosshead as they move axially, during propeller pitch translation.

The crosshead chamber is designed to contain a constant volume of oil to prevent pressure surges caused by variable seal loadings. Variable seal loadings are caused by piston rod travel within the chamber during pitch translation. As the piston rod moves into or out of the crosshead chamber during pitch translation, it changes the chamber volume. The forward end of the piston rod covers or uncovers an equal volume of the tail-shaft spigot, thereby cancelling the effect of volume change.

Two low-pressure safety valves are located in the tail-shaft spigot. One of these valves is shown in figure 8-21. Overpressurization in the crosshead chamber, resulting from expansion of the oil caused by thermal change, opens the safety valves and bypass oil to the return oil passage. If the return oil pressure exceeds the crosshead chamber pressure, the oil can flow past the piston rod seal into the crosshead chamber.

The hub purge valve is located in the hub body end plate that separates the servomotor cylinder from the crosshead chamber. The purpose of the purge valve is to purge oil from the forward chamber of the servomotor cylinder when the propeller is stroked beyond its design full astern pitch limit. If the propeller is stroked beyond its design full astern limit, the crosshead contacts the purge valve, causing the valve to open. The open valve permits oil to flow from the cylinder into the crosshead chamber. When the pressure in the crosshead chamber exceeds the pressure setting of the tail-shaft spigot safety valves, the safety valves open. The oil then flows into the return oil passage, completing the hub purge circuit.

## **VALVE ROD ASSEMBLY**

The valve rod assembly is the mechanical link between the OD box and the hub servomotor regulating valve. It also provides the flow path

for hydraulic power oil from the OD box to the regulating valve. The rod is assembled from fabricated sections of seamless steel tubing joined together by oil-tight couplings. The aft end of the rod is mechanically connected to the regulating valve pin. The forward end is mechanically connected to the distance tube in the OD box. The distance tube is part of the OD box piston assembly. This provides a positive drive for the valve rod. Relative to the propeller shaft, the distance tube is keyed to axial slots in the OD box extension shaft to prevent rotation of the rod.

Axial movement of the valve rod is actuated and controlled by the OD box piston assembly. As the valve rod translates, it moves the regulating valve pin axially in the valve liner. The movement of the valve pin ports hydraulic power oil to either side of the servomotor piston. This in turn results in propeller blade pitch rotation. The amount of axial travel of the valve rod is equal to the travel of the hub servomotor piston.

## **OIL DISTRIBUTION BOX**

The OD box has two main purposes: (1) It provides the actuation and control of the regulating valve rod, and (2) it directs HP hydraulic oil to and from the propeller shaft flow passages. It also provides the mounting for the manifold block assembly, local pitch indicator, linear feedback potentiometer, and shaped readout potentiometer of the control valves.

The regulating valve rod is actuated and controlled by the OD box piston assembly, shown in figure 8-23. This assembly consists of a forward and an aft piston mechanically connected to make a double-ended piston. The piston fits between the forward and aft control oil chambers of the OD box. Not shown in figure 8-23 are molythane polypak seals which are installed in the piston heads and in the annular packing gland separating the chambers. Each chamber has a single port for normal supply and return of control oil. Each chamber also has a single emergency port for connection of the emergency hand pump.

Control oil pressure of 350 psig is ported to either control oil chamber by the control valve manifold assembly. It responds to either an

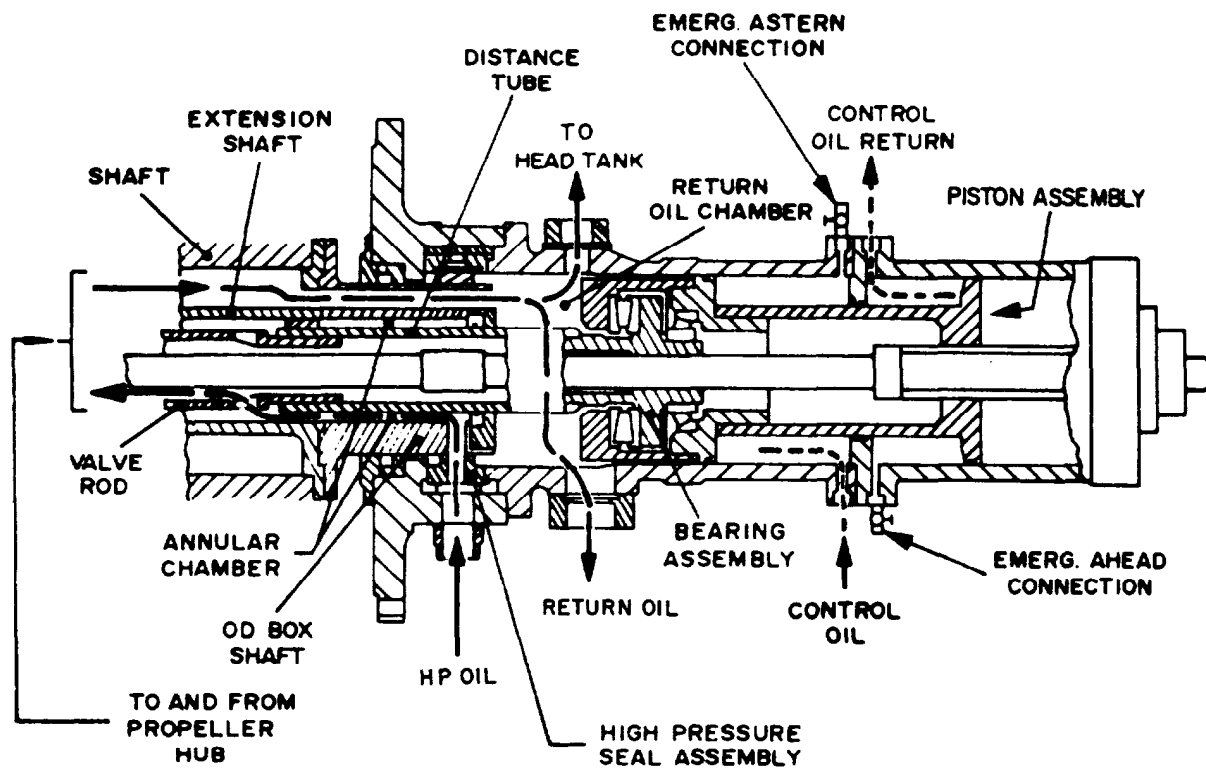

OIL FLOW FOR PITCHING ASTERN

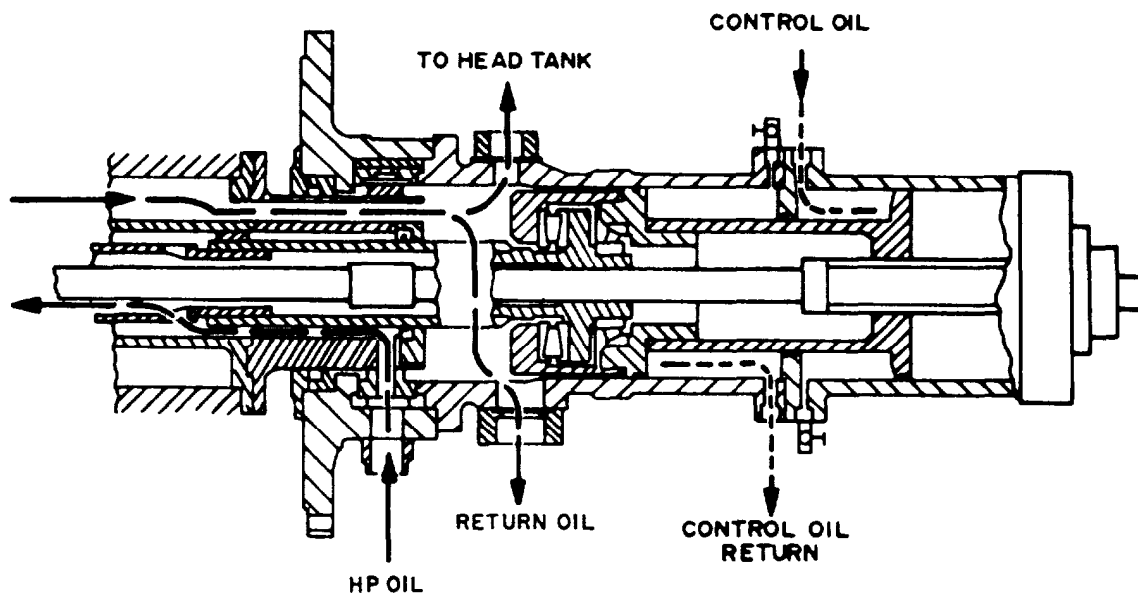

OIL FLOW FOR PITCHING AHEAD

Figure 8-23.—Oil distribution box.

electrical or manual pitch change command. If the command is for pitch change ahead, control oil is ported to the forward control oil chamber; the aft control oil chamber port is open to return, causing the piston assembly to move forward. This translates the valve rod forward, resulting in propeller pitch change in the ahead direction. As the piston assembly moves forward, the oil in the aft control oil chamber is displaced through the aft chamber port by the aft piston. If the command is for pitch change astern, control oil is ported to the aft control oil chamber and the action is reversed. The oil flow directions are indicated in figure 8-23.

The piston assembly is mechanically connected to the valve rod by a bearing assembly and distance tube. The bearing assembly is necessary for the transfer of the axial forces since the piston is stationary, while the distance tube and valve rod rotate with the propeller shaft. The bearing assembly also absorbs the thrust load of the valve rod.

If a failure of the normal pitch control system occurs, an emergency system is provided. The control valves and emergency pump assemblies are shown in figure 8-24. A hand-operated hydraulic pump can be connected to the emergency ahead and astern control oil ports located adjacent to the normal ports. A four-way selector valve on the emergency pump is used to direct pump output pressure to the forward or aft control oil chamber for the desired pitch. A locking device on the OD box end cover enables the propeller to be locked in the emergency ahead position for sustained operation. In the locked position, a machined shoulder on the locking device mechanism within the OD box engages the forward piston and mechanically locks the piston in position.

A follow-up rod is connected to the forward piston and extends through a penetration in the end cover. Externally, the follow-up rod is connected to a local pitch indicator and two sliding-contact potentiometers mounted on top of the OD box. The potentiometers provide feedback and pitch readout signals to the electronic pitch control system. The local pitch indicator is a pointer which slides along a scale calibrated in feet of pitch. The indicator scale extends over the end of the OD box and reads from 15 feet astern to 28 feet ahead. It has a separate notch

at the forwardmost end indicating EMERG AHEAD.

## **CONTROL VALVES MANIFOLD BLOCK ASSEMBLY**

On the OD box is a manifold block assembly. This assembly houses the two four-way changeover valves, the electrohydraulic servo control valve, and the manual control valve. It is referred to as the control valves manifold block assembly and is shown in figure 8-24. Its function is to direct the flow of control hydraulic oil from the HOPM to the control oil section of the OD box. It responds to an electrical or manual input to control propeller pitch.

The two four-way changeover valves are used to select the operating mode. Each valve has a selector handle with a pointer and a dial. The dials are labeled MAN-OFF-AUTO. Both selector handles must be placed in the same mode for proper operation of the system. The OFF position of the changeover valves is used only when they are being operated with the emergency pitch positioner.

In the AUTO (automatic) mode, the electrohydraulic control oil servo valve directs the control oil flow to the OD box. It responds to an electrical signal from the electronic pitch control unit located in each engine room.

In the MAN (manual) mode, the manual control valve directs the control oil flow to the OD box in response to movement of the valve lever. The manual control valve has a control handle with three positions labeled AHEAD, OFF, and ASTERN. The control handle is spring-loaded in the OFF (center) position. Movement of the control handle in the desired direction, that is, AHEAD or ASTERN, will result in a pitch change. It is held in that position until the desired pitch has been attained. When the desired pitch has been reached, the handle is released. It returns to the OFF position by the spring force, and the propeller pitch holds at the new position.

## **HYDRAULIC OIL POWER SYSTEM**

The purpose of the hydraulic oil power system is to supply both HP hydraulic oil for propeller blade actuation and control oil for propeller pitch control. A schematic of the hydraulic oil system

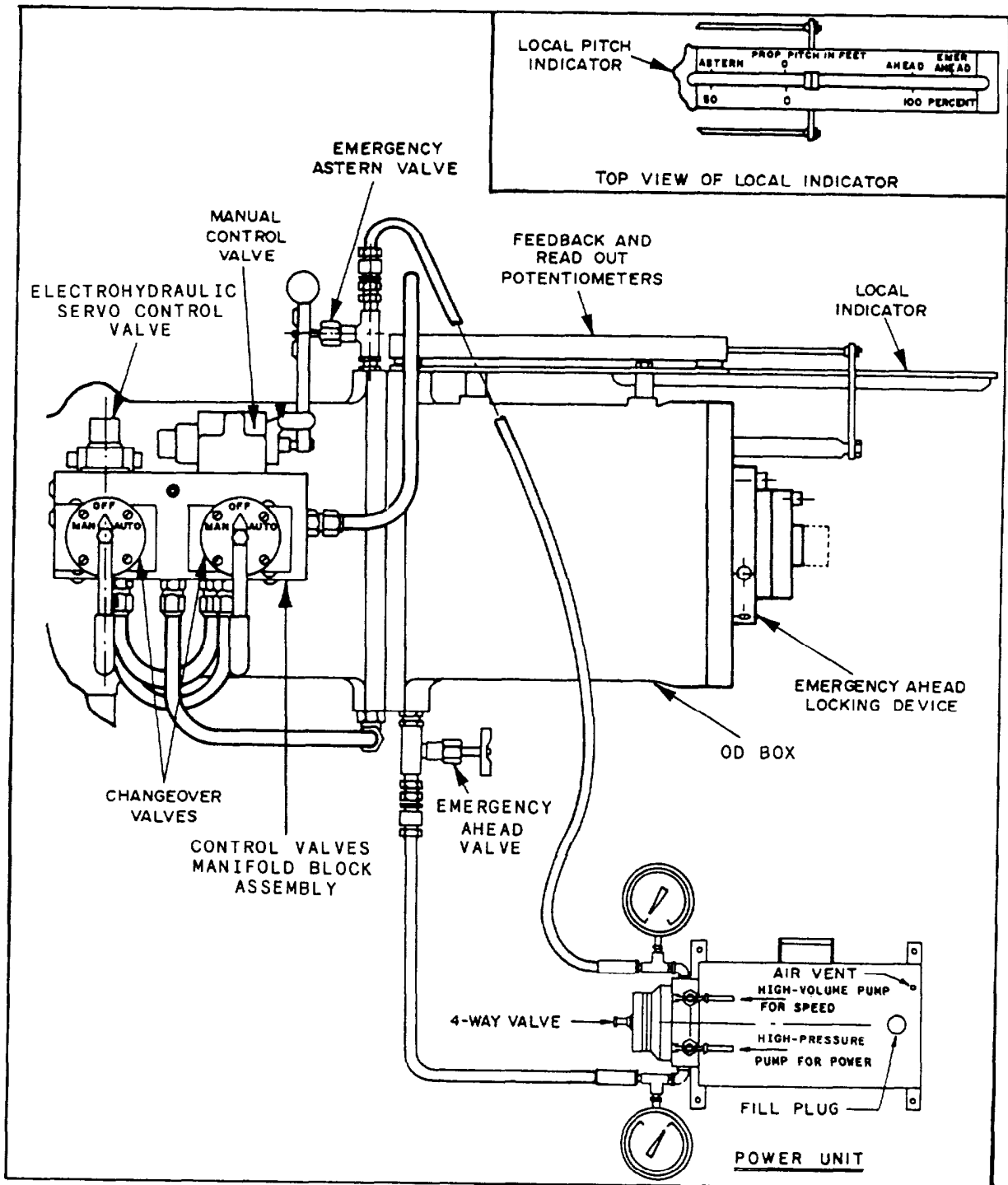

Figure 8-24.—Control valves and emergency pump assemblies.

used is shown in figure 8-25. The system consists of an HOPM; a gear-driven attached or gear hydraulic pump; the manifold block assembly of the control valve; and associated piping, valves, and fittings.

### Hydraulic Oil Power Module

The HOPM is located adjacent to the MRG. It contains the motor-driven, screw-type electric or motor operated hydraulic oil pump, a suction strainer, two duplex filters, and a pressure control assembly. It also contains a duplex control oil filter, two gauge panel assemblies with associated instrumentation, a manual bypass valve, and interconnecting piping and fittings.

The motor-driven electric or motor operated hydraulic pump draws oil from the sump tank through a foot valve and a suction strainer. The foot valve allows oil flow in one direction only, thus preventing the backflow of oil from the pump to the tank when the pump is shut down. The suction strainer is a telltale, bypassing type of strainer. An indicator on the strainer indicates the degree of clogging. If the indicator is ignored and the degree of clogging becomes extensive, the oil is internally bypassed around the strainer element. The hydraulic pump delivers 160 gpm at up to 1,000 psig. From the pump, the oil flows through a duplex filter to the pressure control assembly. An air bleed valve, located between the pump and the filter, automatically purges entrapped air from the system. It also aids initial start-up and priming of the pump.

You can start or stop the HOPM electric pump motor from the CCS or from a local motor controller located adjacent to the HOPM. The motor controller has a two-position transfer switch with the positions labeled LOCAL and REMOTE. The LOCAL position allows the electric pump motor to be operated from the local controller and at the same time inhibits operation from the consoles. The REMOTE position allows the electric pump motor to be operated from the consoles, while inhibiting operation from the local controller.

The pressure control assembly (seen in fig. 8-25) regulates the HP (power) oil and control oil that is supplied by the HOPM. The assembly consists of a pilot-operated unloading valve and check valve together in one housing, a motor-driven pump check valve, a relief and sequence valve together in another housing, a pressure-reducing valve, and an auxiliary relief valve. During normal operation, both the electric or motor operated HOPM

pump and the attached or gear hydraulic pump are running. The electric or motor operated pump normally supplies the hydraulic oil flow, while the attached or gear pump flow is returned to the sump tank by the unloading valve. The check valve prevents the electric or motor operated pump discharge from entering the attached or gear pump. If the electric or motor operated pump fails or the pressure drops below minimum, the pilot-operated unloading valve directs the flow from the attached or gear pump to the electric or motor operated flow path. In this mode, discharge from the attached or gear pump is prevented from entering the electric or motor operated pump by the electric or motor operated pump check valve.

The hydraulic oil flow next enters the relief and sequence valves. An unloading valve is used to maintain system pressure. The sequence valve acts to maintain a minimum hydraulic oil pressure of 350 psig at the inlet of the control oil pressure-reducing valve. High-pressure oil for the propeller hub leaves the sequence valve at a pressure of 200 to 600 psig. If the oil pressure exceeds the maximum limit of 1,000 psig, the relief valve opens and excess pressure is bled off to the sump tank. Oil from the pressure-reducing valve (control oil) flows at reduced pressure (10 gpm at 350 psig nominal). It flows through a duplex filter to the control oil section of the OD box. If the control oil pressure exceeds 600 psig, the auxiliary relief valve opens and the excess pressure is bled off to the sump tank.

A manually operated bypass valve is located in a line between the sequence valve discharge and the return line to the sump tank. This valve is normally closed during operation.

A spring-loaded check valve is located in the hub oil return line between the OD box and the HOPM. It maintains the return oil pressure between 28 and 35 psig during system operation. It assures a positive pressure on the return line during system shutdown. At this time, the CRP head tank provides the only source of return line pressure.

The attached or gear hydraulic pump is a vertically mounted, screw-type pump identical to the motor-driven electric or motor operated pump. It is driven by the MRG. The pump draws oil from the sump tank through a foot valve and suction strainer identical to those in the electric or motor operated pump system. The discharge from the attached or gear pump flows through a duplex filter, located in the HOPM, to the pilot-operated unloading and check valve.

### Oil Distribution

As discussed earlier, there are three oil systems common to all CPP/CRP systems. They are the

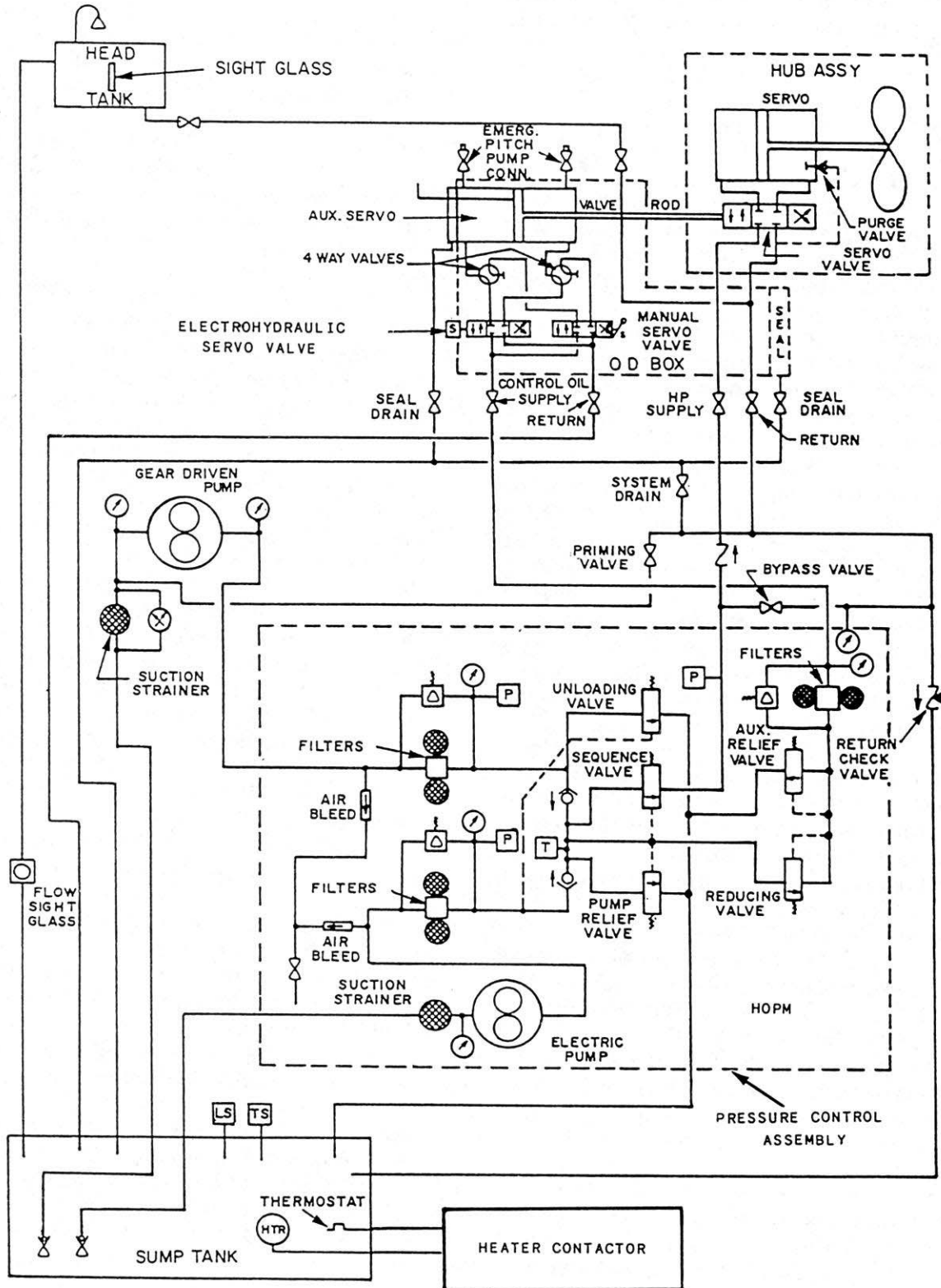

Figure 8-25.—CRP hydraulic system schematic.

control oil system, the power oil system, and the return oil system. In the following section, we will describe these systems.

**CONTROL OIL.**—Control oil from the HOPM enters the OD box through the control valves manifold block assembly. Figure 8-26 shows the control oil line entering the control valves manifold block assembly and dividing with two separate flow paths. One leads to the electrohydraulic servo valve and the other leads to the manual control valve. The outflow lines of these valves meet at two changeover valves. One changeover valve allows oil to pass in or out of the astern OD box piston chamber through a single line. The other changeover valve allows flow into or out of the forward OD box piston chamber through a single line. Each changeover valve determines which control valve (servo or manual) outflow is going to pass through to the OD box. With the changeover valves in the MANUAL position, only the control oil passing through the manual control valve can pass through the changeover valves to the OD box. The AUTO position passes only the control oil from the electrohydraulic servo valve. When the changeover valves are in the OFF position, no oil can flow in or out of the OD box except through the emergency hand pump connections.

During normal control oil flow, with the changeover valves in the AUTO position, the servo control valve is opened by signals from the electronic pitch control system to increase pitch in the astern direction. Control oil flows through the servo control valve and the astern changeover valve to the astern pitch connection on the bottom side of the OD box. Entry of oil into the astern piston chamber causes the piston assembly to move aft, thus translating the valve rod for a pitch change astern. As the piston assembly moves aft, the oil in the forward piston chamber is pushed out through the forward pitch connection located on the top side of the OD box. This return control oil flows out through the forward changeover valve to the servo control valve. It then passes to the return oil line that leads back to the sump.

If ahead pitch is ordered, the servo control valve switches the flow path. This causes oil to enter the forward pitch connection on the OD box rather than the astern pitch connection. Oil returns from the astern pitch connection, and the flow is reversed from the situation described in the previous paragraph. The manual control valve directs the control oil flow in the same way as

described previously. The only difference is that the valve is operated manually through a lever, as opposed to the servo control valve which is operated electrically through a solenoid.

The emergency pitch connections are used when control oil or HP oil are not available from the HOPM. As seen in figure 8-23, the emergency connections supply oil to the OD box piston in the same manner as the normal connections. The difference is that the control oil must be supplied from a special hand pump and a much higher pressure is required.

**POWER OIL.**—High-pressure hydraulic oil from the HOPM enters the OD box through a flange connection on the bottom aft section (fig. 8-23). The flange passes the oil to an annular channel in the stationary HP seal assembly. The HP seal ring, which seals the top of the annular channel, is attached to the OD box shaft. As the OD box shaft turns, the HP seal ring rotates in the top of the channel. Holes drilled through the HP seal ring and continuing through the OD box shaft conduct the HP oil from the annular channel in the HP seal assembly to an annular chamber formed between the OD box shaft and the distance tube. This chamber directs the oil slightly aft to where it enters the regulating valve rod through two drilled passages. The HP oil then continues through the valve rod to the propeller hub.

**RETURN OIL.**—Return oil from the hub, which is called LP oil, flows forward through the passage between the outside surface of the valve rod and the inside surface of the propeller shaft. The return oil enters the OD box through six passages drilled in the OD box shaft between the propulsion shaft and the OD box shaft extension. The six passages direct the oil to a relatively large annular return oil chamber. Any leakage past the HP seal also enters the return oil chamber. Return oil is discharged from the return oil chamber back to the CRP sump through a flange connection. This flange connection is located just forward of the HP oil inlet connection.

The CRP head tank connects to the return oil chamber through a flange located on the top aft section of the OD box. This location places the head tank above the OD box. The overflow line allows the 65-gallon tank to hold 40 gallons before passing oil back to the sump. The purpose of the head tank is to maintain a static head pressure on the oil in the propeller hub when the hydraulic system is shut down. This prevents seawater from

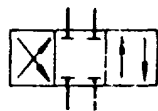
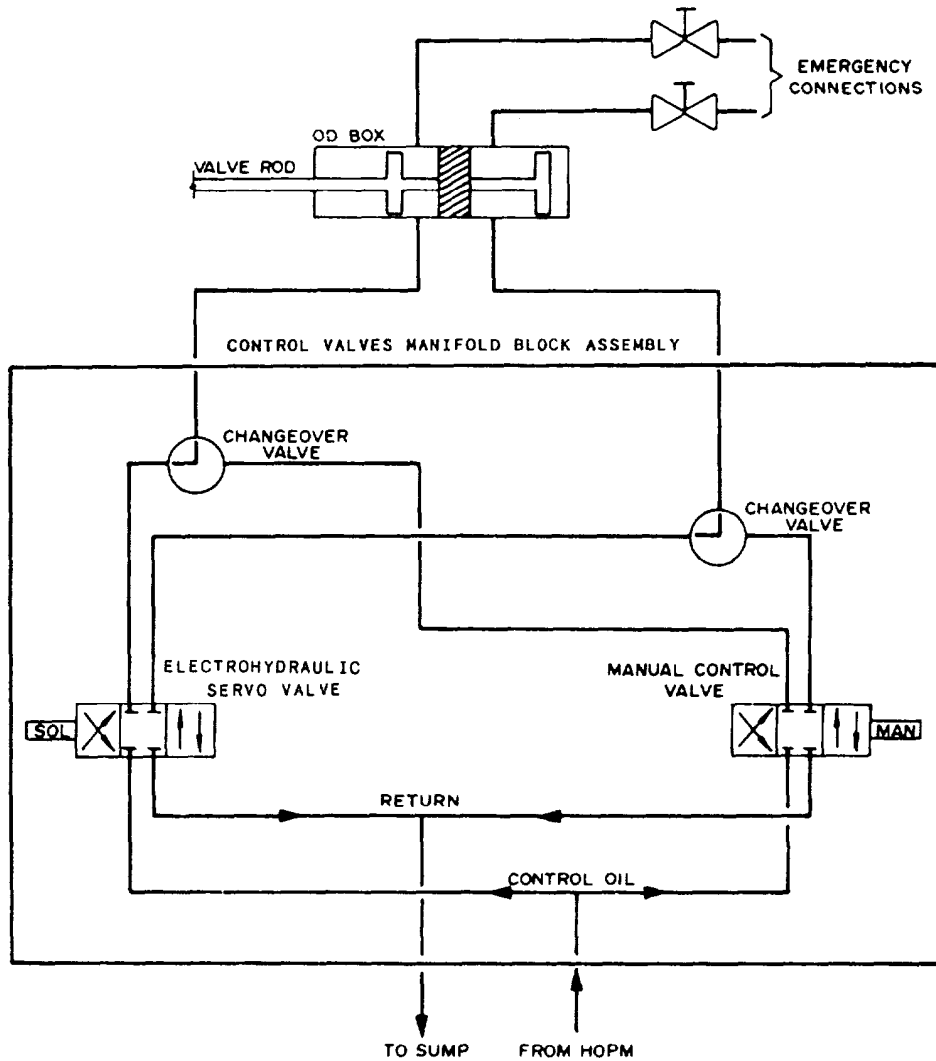

SYMBOL INDICATES THREE POSITION VALVE. LEFT BLOCK SHOWS THAT 1ST VALVE POSITION CONNECTS THE PORTS DIAGONALLY. CENTER BLOCK REPRESENTS THE OFF POSITION. RIGHT BLOCK SHOWS THAT 3RD VALVE POSITION CONNECTS THE PORTS VERTICALLY.

Figure 8-26.—Control valve manifold oil flow.

leaking past the blade seals and into the hydraulic system. Hydraulic oil continually fills the head tank from the return oil chamber and flows back to the sump through the overflow line when the HOPM is providing HP oil. This head tank circulation is caused by the return check valve in the return oil line. When the HOPM is operating, the check valve maintains approximately 28 to 35 psig in the return oil chamber. Since 28 to 35 psig is greater than the head pressure caused by the tank height, return oil continuously fills the tank, and it overflows back to the sump. When HP oil

to the propeller is shut off, the check valve prevents the head tank from draining back into the sump. The head tank then provides sufficient pressure to prevent seawater entry through the hub seals since it is 4 to 6 feet above the ship's waterline.

### ELECTRONIC PITCH CONTROL SYSTEM

The pitch of the CRP propeller is established electrically through the electrohydraulic pitch



control systems located in the engine room. The system has two basic parts or groups of components. One part of the system is the CRP electronics enclosure mounted on vertical stanchions near the free-standing electronics enclosure (FSEE) in each engine room. The other basic group is the components mounted on the OD box. This group consists of the control oil servo valve and two slide-type potentiometers. Figure 8-27 shows the relationship between the two basic parts of the system. Although the systems for each shaft are identical, they are also independent. The propeller pitch on the starboard shaft can be set to the same value or to a different value than the port shaft pitch. The setting depends on what is ordered through the consoles.

Electronic pitch control begins with the pitch command signal generated by the console. The command signal is sent to the CRP electronics enclosure. It then causes a servo valve position signal to be sent to the control oil servo valve on the OD box. The servo valve is driven off center and allows control oil to enter the OD box piston chamber, thus moving the control piston and valve rod assembly. The direction in which the servo valve opens is determined by the command

signal polarity. The follow-up rod is attached to the forward end of the piston and extends through the OD box end cover. It moves with the valve rod assembly and positions a pointer on the OD box pitch indicator. The follow-up rod also positions the sliding contacts on the two OD box potentiometers. The shaped potentiometer provides the signal source for electronic display of the actual blade pitch. The linear potentiometer provides the feedback signal that cancels the pitch command signal. It also provides the feedback signal that allows the control oil servo valve to close when the pitch ordered by the pitch command signal has been reached. The CRP electronics enclosure provides the supply voltage for both potentiometers. Besides providing control and potentiometer voltages, the CRP electronics enclosure receives the potentiometer feedback and position signals. It also supports a local five-point pitch level display and a local digital output monitor display intended primarily to aid in testing and calibrating the electronic circuitry.

### Control Oil Servo Valve

The control oil servo valve located on the OD box is an electrohydraulic valve. It uses an

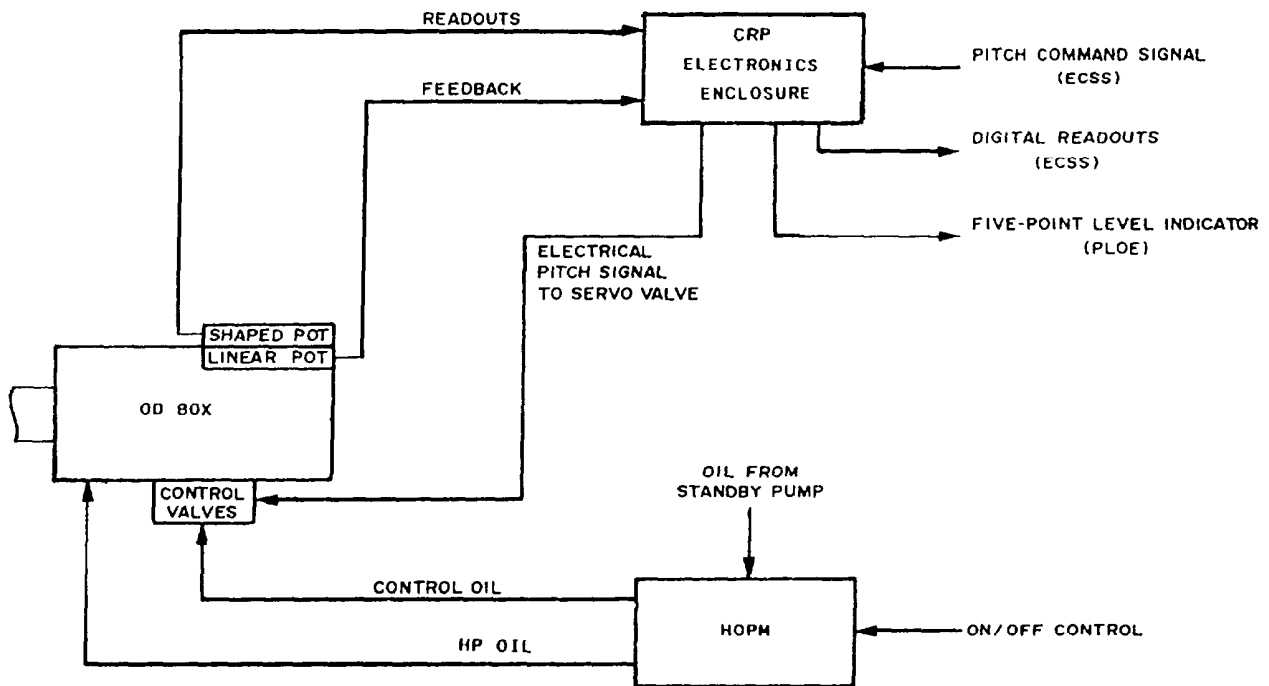

Figure 8-27.—Electrical and hydraulic signal flow between CRP system components.

electric solenoid and internal hydraulic pressure to actuate the valve component that controls oil flow through the valve. The function of the control oil servo valve is to pass control oil to the ahead or astern side of the OD box piston. The OD box piston, in turn, changes the pitch of the propeller blades.

The control oil servo valve is electrically actuated by the servo valve controller circuit card contained in the CRP electronics enclosure. Two conductors carry the servo signal from the electronics enclosure to a terminal box mounted near the OD box in each engine room. At the terminal box, the two conductors from the electronics enclosure are doubled. This provides a four-conductor cable that carries the signal from the terminal box to the servo valve. The four conductors connect to the two coils of the servo valve solenoid in a parallel configuration. Each coil has a dc resistance of 1,000 ohms. If an ohmmeter is used to measure the total resistance of the solenoid, it should read 500 ohms when measured from the two conductors that run between the electronics enclosure and the terminal box. The absolute value of the maximum voltage that should appear on the servo valve solenoid is approximately 7.2 volts.

The solenoid discussed in this manual is more correctly called a **torque motor**. The coils are wrapped around a small plate called the **armature**. When a dc voltage is applied to the coils, the armature flexes in reaction to the current flow within the magnetic field. The magnetic field is established by permanent magnets mounted in the torque motor housing. Direction of armature movement depends on the dc voltage polarity. The magnitude of armature movement depends on the strength of the dc voltage. The dc voltage can be from 0 volts to 7.2 volts of either positive or negative polarity. A small pilot valve is attached to the armature. When the armature is moved, it unbalances the internal oil pressure and causes the valve to rotate and open the ahead or the astern valve port. With zero voltage applied to the coils, the pilot valve is centered by internal oil pressure so that the valve component also becomes centered by the oil pressure. Oil is then unable to

flow in or out of the servo valve ports leading to the OD box piston chambers. Therefore, pitch remains unchanged.

The servo valve has four ports bored in the mounting base. These ports are for incoming control oil, outflow to the astern pitch side of the OD box piston, outflow to the ahead pitch side of the OD box piston, and oil return to the hydraulic oil sump. These ports line up with passages drilled in the control valves manifold block assembly on which the servo valve is mounted.

### OD Box-Mounted Potentiometers

The linear feedback and shaped potentiometers are mounted side by side on the top of the OD box. Each potentiometer is housed in a rectangular box about 18 inches long, 1 1/2 inches wide, and 1 1/2 inches tall. A shaft which moves the sliding contact extends out of the forward end of each potentiometer box. A Y-shaped yoke connects the ends of the potentiometer shafts to the end of the follow-up rod that extends out the forward end of the OD box. The follow-up rod provides a mechanical positioning of the potentiometer shafts that corresponds to actual propeller pitch positions. The follow-up rod also positions a mechanical pointer along a calibrated scale mounted between the potentiometers. Slots in the potentiometer mounting feet provide for longitudinal position adjustments when the zero pitch feedback and readout signals are calibrated.

**LINEAR POTENTIOMETER.**—The linear potentiometer provides the pitch feedback signal to the servo valve controller card in the CRP electronics enclosure. The resistance element is approximately 10 kilohms from end to end. The term *linear* means that the resistance is evenly distributed along the potentiometer body and that the voltage picked up by the sliding contact is proportional to its position along the potentiometer body.

**SHAPED POTENTIOMETER.**—The shaped potentiometer generates the pitch readout signal. The pitch readout signal is used to display pitch on the five-point indicator at the PLCC and on the digital demand display

at the ECSS operating station. The resistance across the shaped potentiometer from end to end is about 15 kilohms. The word *shaped* is used to describe this potentiometer because the resistance is not evenly distributed along the potentiometer body. Slightly more resistance (ohms per inch of potentiometer) is at the ends than in the middle. This nonlinear resistance distribution is necessary to compensate for the increased sensitivity of the propeller pitch to the valve rod positioning at the extreme ahead and astern pitch settings. As maximum ahead or maximum astern pitch is approached, a lesser change in valve rod position is needed to obtain a certain pitch change. More change is needed if the blades are closer to zero pitch. This is caused by the decreased angle between the valve rod and the lever arm formed by the center post of the blade and the sliding block crankpin. So, an increase in potentiometer resistance is necessary at both ends to reflect the same pitch change on the electronic readout devices with less valve rod change (equal to follow-up rod change).

## PRAIRIE AIR SYSTEM

Prairie air is emitted from small holes drilled in the leading edges of the CRP propeller blades. The discussion presented here deals only with the PA flow in the OD box, along the propulsion shaft, and from the hub assembly to the propeller blade leading edges.

PA is piped from the PA cooler to the roto seal on the forward end of the OD box. The roto seal passes air from the stationary external piping to the rotating PA tube in the center of the OD box piston assembly. The PA tube consists of sections of seamless, stainless steel tubing connected by welded couplings containing O-ring seals. The tube runs aft through the centers of the OD box piston assembly, the bearing support, the distance tube, and the valve rod to the propeller hub assembly. The tube is held in the center of the valve rod by welded-on guides that support the tube away from the valve rod inner wall. At the aft end of the hub, the PA tube terminates with a check valve in the hub cone end

cover. The check valve discharges PA into drilled passages in the hub cone end cover. The end cover passages connect with passages in the hub cone and hub body to direct the PA to the center post of each blade. The PA flows from the center post through a bushing connection to a drilled passage in the root of the blade. The drilled passage directs the air to a machined channel under the leading edge. From the channel, the PA discharges into the water through small orifices drilled in the blade edge.

Two check valves in the PA tubing prevent entry of seawater into the system when the PA is not being used. The primary check valve is installed in the hub cone end cover as mentioned previously. It limits seawater backflow to the propeller blades and hub cone. A backup check valve is located in the OD box at the connection between the PA tubing and the roto seal. Should the primary check valve fail, the backup check valve will prevent seawater from passing through the roto seal and filling the shell of the PA cooler.

## PROPULSION SHAFTING SYSTEM

The propulsion shafting system consists of the propulsion shafts, the line shaft bearings, the strut bearings, the stern tube bearings, the bulkhead seals, and the stern tube seals. The following description of the propulsion shafting equipment is representative of types found aboard the various gas turbine ships. Consult the manufacturers' technical manuals for specific information concerning your ship.

## SHAFTING

The shaft transmits propulsion torque to the propeller and thrust to the Kingsbury thrust bearing. In addition, the shaft is designed to accommodate the CRP propeller hydraulics and PA tubing. The PA tubing runs through the propulsion shaft at the center line. The center line is surrounded by the propeller valve control rod, as seen in figure 8-28. High-pressure hydraulic oil from the HOPM is supplied to the propeller hub through the interior of the valve rod. Oil returns from the hub to the sump tank in the annular

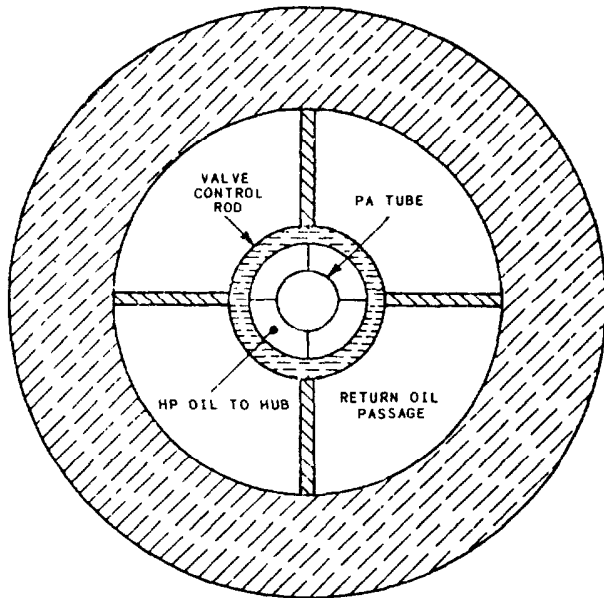

Figure 8-28.—Cross-sectional view of propulsion shaft.

space between the valve rod and the inside diameter of the propulsion shaft. It then flows through the OD box to the hydraulic oil sump tank.

## SHAFT BEARINGS

The shaft bearings are used to support the shaft. Bearings are mounted in the stern tube and propeller strut and are seawater lubricated. The remaining bearings are self-aligning, oil-lubricated journal bearings commonly called line shaft bearings (LSBs). Each LSB is a self-contained assembly with its own oil reservoir that contains 2190 TEP oil.

An oil disc clamped to the shaft is used in each bearing to deliver oil to the upper bearing and journal surfaces. As the disc rotates, it picks up oil from the bearing reservoir and carries it to the oil scraper on the upper shell. The scraper removes oil from the disc and directs it to the upper bearing lining. A clear sight hole cover on the bearing housing allows visual confirmation of the oil level and oil disc operation.

All bearing pedestals have an oil level rod and an oil reservoir thermometer for checking oil level and temperature. An RTD is installed in the lower bearing shell of each oil-lubricated bearing. The

RTDs provide for remote readout of each bearing's temperature on the digital demand displays.

## Strut Bearings

Each propeller shaft extending aft of the stern tubes is supported by a strut. Each strut contains a seawater-lubricated bearing. The strut bearings are cooled by constant immersion in seawater and are not monitored by the ECSS.

## Stern Tube Bearings

The stern tube bearings are in constant contact with the seawater surrounding the stern tubes. The clean seawater that passes through the stern tube seals from the ship's firemain system or seawater service system also flows through the stern tube bearings. They are identical to the strut bearings in design. However, the strut bearings are roughly 5-inches larger in diameter and twice as long as the stern tube bearings. The stern tube bearings are not monitored.

## PROPULSION SHAFT SEALS

The propulsion shaft penetrates the hull and various compartment bulkheads. At these points it is necessary to install some type of sealing arrangement to prevent progressive flooding between compartments. Where the shaft penetrates a compartment bulkhead, they are naturally called bulkhead seals. Where the shaft penetrates the hull, they are called stern tube seals.

## Bulkhead Seals

The bulkhead seals will maintain watertight integrity of the bulkhead penetrated by shafting when either side of the bulkhead is flooded. These seals are self-aligned with the shaft. They will accommodate  $\pm 1.75$  inches perpendicular movement of the shaft with longitudinal movement of 0.040 inches because of thrust bearing clearance and 0.50 inch because of thermal changes.

The seal assembly consists of a base ring bolted to the bulkhead, two sealing discs, right-hand and left-hand sealing rings, and a cover. The two sealing rings are identical, except that one is a mirror image of the other. They are formed by three plain and three slotted carbon segments. Six pressure ring

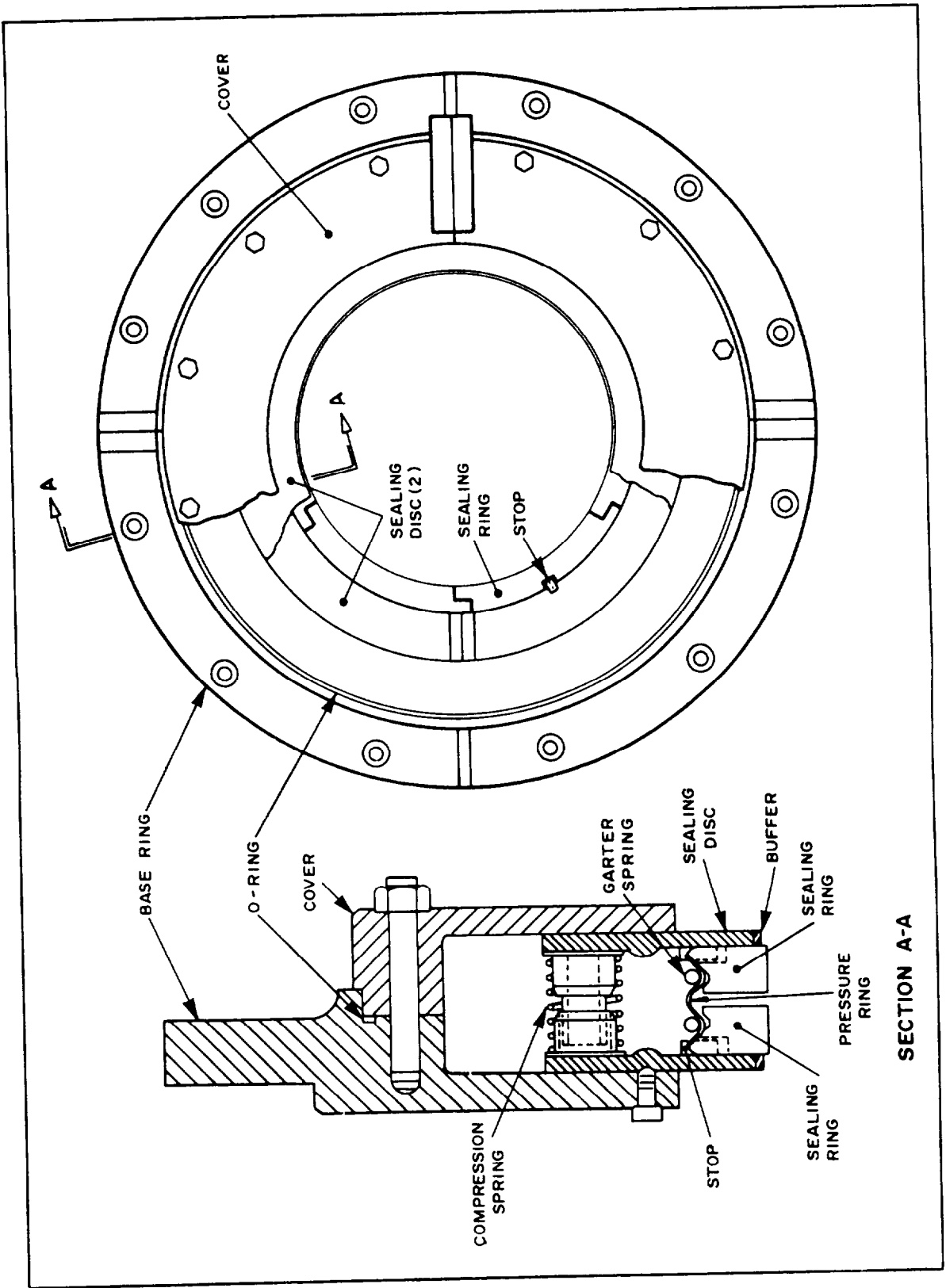

Figure 8-29.—Bulkhead seal assembly.

segments (fig. 8-29) are placed around the two carbon sealing rings, and the assembly is held in place by two garter springs. The two sealing discs are installed with one on either side of the sealing rings. Attached to each sealing disc are three stops that mate with the slotted carbon segments. These stops ensure that the sealing ring assembly does not rotate with the shaft.

When the compartment on one side of the seal is flooded, water pressure on the carbon sealing ring on the wet side creates a gap between the carbon ring and sealing disc. This gap allows water to enter the seal housing to force the other sealing ring against the shaft and sealing disc. Pressure on the far side sealing ring is directly proportional to the head of water in the flooded compartment plus the contact pressure of the garter spring. Sealing action is a direct function

of water pressure, so flooding is confined to the one compartment only.

### Stern Tube Seals

The purpose of the stern tube seals is to prevent seawater from entering the ship at the point where the shaft or shafts penetrate the hull.

Different types of stern tube seals are installed aboard ships, but they all serve the same purpose. We will use the MX9 model installed on the DD-963 class ships as an example of a stern tube seal.

The MX9 seal (fig. 8-30) is a radial face, hydraulically balanced seal located on the inboard side of the ship's stern tube. Primary sealing occurs between the stationary face insert and the rotating seat in a plane perpendicular to the center line of the shaft.

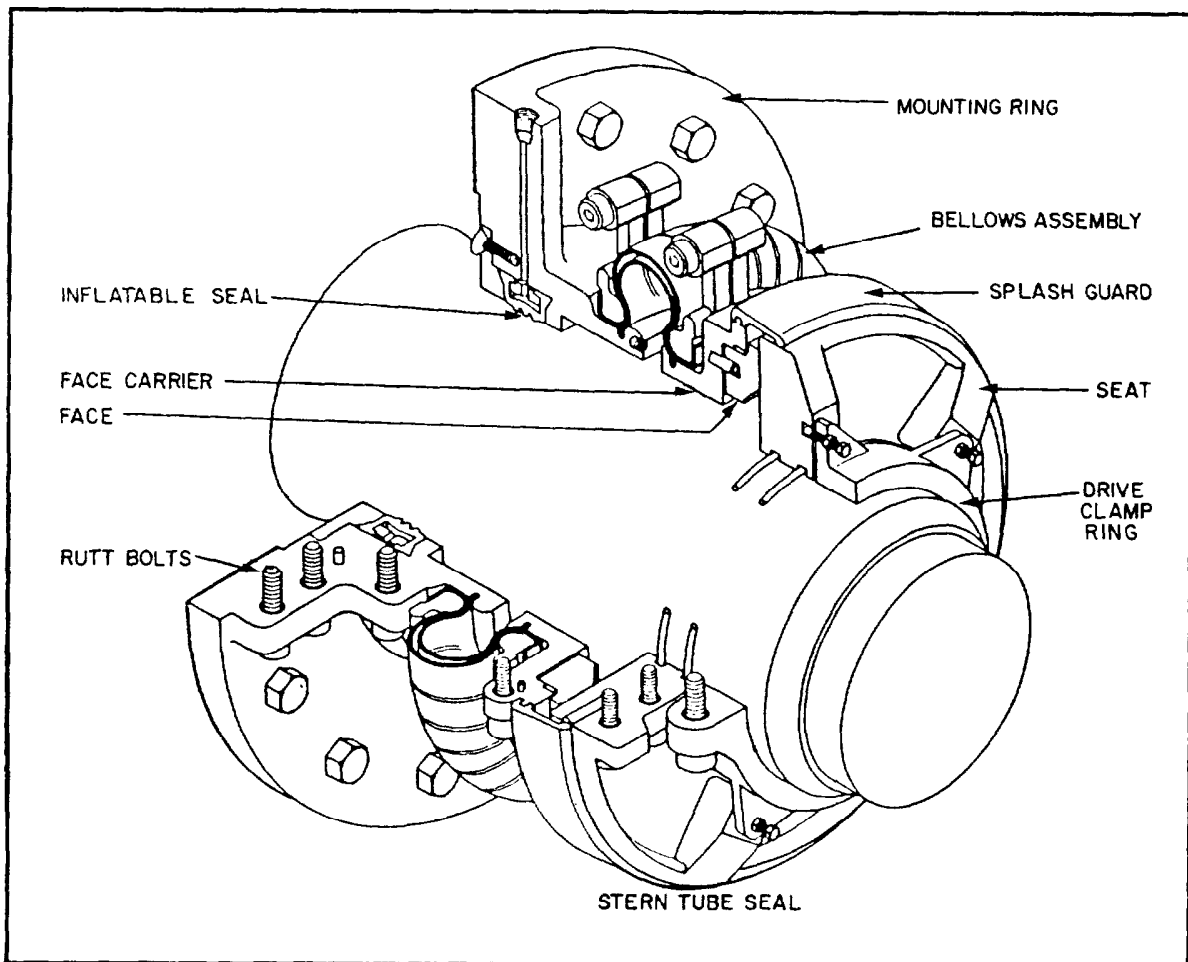

Figure 8-30.—MX9 stern tube seal.

Face to seal contact pressure is maintained by the force of the springs, which is developed in the bellows seal assembly, and by the hydraulic forces induced onto the components of the seals by the seawater being sealed. This combination of spring and hydraulic forces maintains a consistent face contact pressure and consistent seal leakage despite seal wear.

The bellows assembly is the flexible member of the seal allowing the seal to accommodate shaft or hull movements caused by thermal differences, thrust loads, vibration, and bearing tolerances.

The seawater flush system is designed to have a seawater flush of 15 gpm and 20 psi. A vent line is also provided to allow passage of any air trapped in the stern tube and seal housing to the atmosphere.

Two backup sealing systems have been incorporated into the stern tube seal; the inflatable seal and a conventional stuffing box.

The inflatable seal is an elastomer channel incorporated into the mounting ring. When the inflatable seal is subject to air pressure, it expands and seals the radial gap between the stern shaft and the seal housing. This allows the seal to be

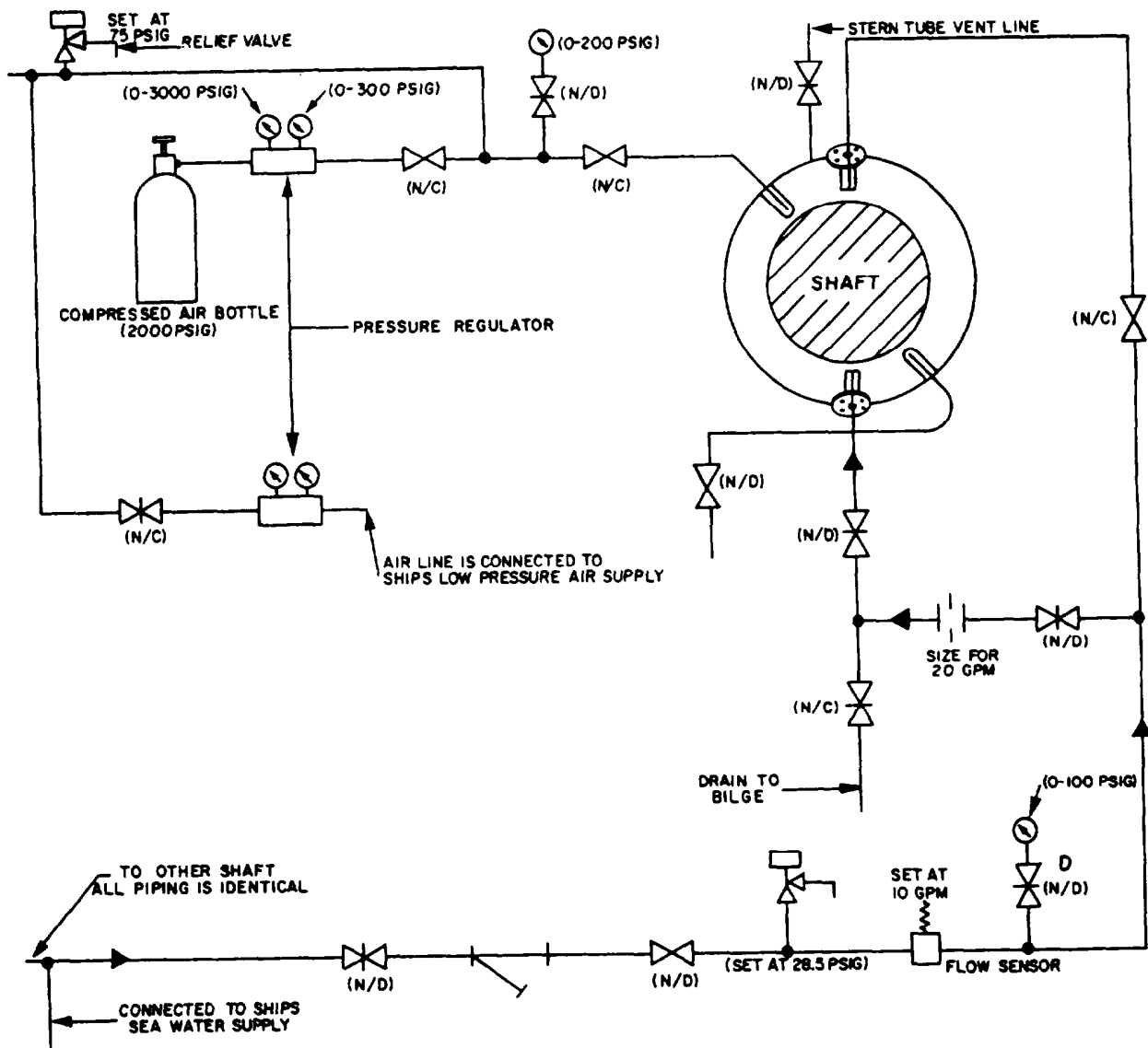

Figure 8-31.—Stern tube piping diagram (typical).

inspected or repaired while the ship is still in the water.

The second sealing system is the stuffing box that has been incorporated into the mounting ring. By first inflating the seal and then removing the seal drive clamp ring, seal, face insert, face carrier, and bellows assembly, you can install packing rings and packing. You can then bolt a gland follower to the mounting ring and adjust it to provide enough leakage for lubrication. You can rotate the shaft but must keep it under observation.

Figure 8-31 is a typical diagram of piping to the stern tube seal. Consult your ship's EOSS for your ship's piping and valve arrangement and pressure settings.

The inflatable seal can be inflated either by ship's LP air or a compressed air bottle.

## SUMMARY

In this chapter, we have provided you with an overview of the power train aboard gas turbine ships. We have described how the power from the GTE is transmitted to the MRG through the shafting to the CRP propeller. This propeller system provides a means for rapid and efficient ship's acceleration and backing down. Knowledge of how the MRG system, CRP system, PA system, and the shafting system are constructed and their operation will be helpful to you in maintaining and operating this vital equipment.





## CHAPTER 9

# ENGINEERING ELECTRICAL EQUIPMENT

Many of the tasks assigned to you involve the operation and maintenance of components of the 60-Hz power distribution system. This may involve work on lighting systems, power panels, motor controllers, motors, receptacle circuits, and distribution switchboards (SWBDs). Most of the 60-Hz electrical equipment you work with is found in the MERs and the CCS. Gas turbine ships also have Electrician's Mates assigned. They are normally responsible for the electrical equipment found outside the main machinery spaces.

The information in this chapter provides you with basic knowledge of the equipment, procedures, terminology, and special precautions used with 60-Hz equipment. After reading this chapter, you should be able to identify 60-Hz equipment. You should be able to identify the different types of generators, motors, SWBDs, circuit breakers (CBs), motor controllers, and uninterruptible power supplies (UPSs) found on gas turbine ships. Also, you should be able to describe the numbering system used to identify electrical equipment and cables.

The material presented in this chapter is basic in nature and explains the principles of operation of engineering electrical equipment. By studying this material, you should be able to relate this information to the specific equipment found on your ship.

### GENERATORS AND MOTORS

Electricity is the most efficient and cheapest means of distributing energy aboard ships. It is the primary method used to distribute energy aboard ship. If electricity were not used, alternate methods, such as the distribution of hot gases and rotating energy, would require massive insulated ducting, heat exchangers, many complex gear-boxes, and shafts. All these systems would make control of this energy very difficult.

Generators are the primary means of converting mechanical energy to electrical energy. Motors are the primary means of converting electrical energy into mechanical energy.

### GENERATORS

The two types of ac generators are

- rotating field—stationary armature, and
- rotating armature—stationary field.

Only the rotating field—stationary armature—is used on gas turbine ships. The size of the generators found on gas turbine ships varies. The FFG-7 class ships have 1000-kW ship's service diesel generators (SSDGs). The DD-963 class ships have 2000-kW SSGTGs. The CG-47, DDG-51, and DDG-993 class ships have 2500-kW SSGTGs.

The two major components of the rotating field-stationary armature are the stator and the rotor (fig. 9-1). The stator (armature) is the

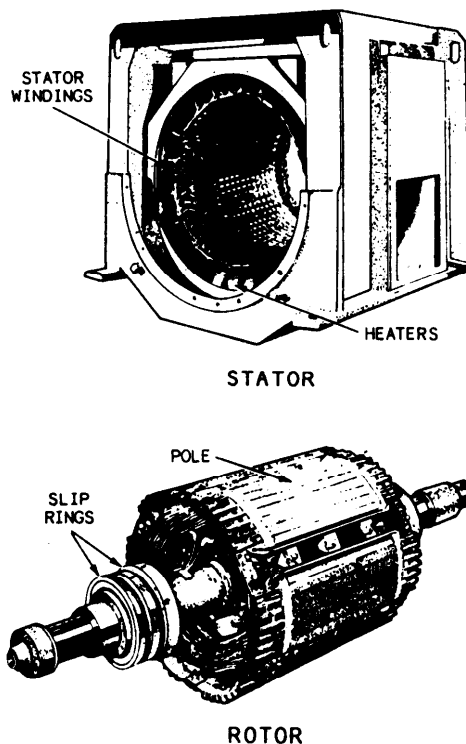

Figure 9-1.—Generator stator and rotor.

stationary part of the generator enclosed in the generator housing and is the set of windings in which voltage is produced. It supplies power to the ship's loads (via a SWBD). The rotor (field) is the rotating part and is driven by the prime mover, either a diesel engine or a GTE. Direct current is induced into the rotor by the voltage regulator circuit to create the rotating magnetic field. The design speed of the generator determines the number of magnetic poles required on the rotor and the frequency output.

Generators on gas turbine ships rotate at 1800 rpm. The rotors of these generators are the salient pole type and have four magnetic poles, two positive and two negative. Field excitation is provided by either slip rings and brushes on a brush-type generator, or a silicon rectifier assembly on the newer brushless generators. The slip rings or the silicon rectifier assembly allows a path of flow for the current from the voltage regulator to the rotor. The magnetic field allows for the transmission of energy from the rotor to the stator. Varying the current to the rotor allows you to control the generator output voltage and the reactive load (amperage).

Brushless ac generators are used in the fleet for ship's service and emergency power. Figure 9-2 compares the brush-type and brushless ac generators. In the brush-type ac generator (fig. 9-2, view A), the current is transferred from the rotating member of the machine to the stationary member and vice versa by the commutator, slip rings, and brushes. Brushless ac generators, on the other hand (fig. 9-2, view B), have a silicon rectifier assembly that replaces this coupling. This development is simple, compact, free of sparking, and greatly reduces the maintenance of generators. Silicon rectifiers are mounted on the rotating shaft to furnish dc to the ac generator rotor field. In the brush-type ac generator, the commutator serves as a rectifier to perform this function. Feedback from the 3-phase power output through a voltage regulator control (not shown) furnishes the correct amount of excitation to the exciter field for ac generator voltage control.

Generator frequency and resistive (kW) load balance (for paralleled generators) are controlled

by the prime mover speed, which in turn is controlled by the installed governor. By adjusting the governor setting on two generators in parallel, an operator can equalize the active kW load and keep the frequency at 60 Hz.

Chapter 4 of this TRAMAN provided information to help you understand the electrical principles concerning electric power. Refer to NEETS, modules 1, 2, and 5, for additional information.

## **MOTORS**

You will be called upon to perform preventive maintenance on 60-Hz ac motors. The size of these motors varies. They can be as large as a lube oil pump motor or as small as a cooling fan motor in an electronics enclosure. Regardless of their size, motor operation is theoretically the same.

The two major types of induction motors you may encounter are the polyphase (3-phase) and the single-phase. The induction motor gets its name from the fact that electromagnetic induction takes place between the stator and the rotor under operating conditions. Most of the large motors found on gas turbine ships are polyphase. Smaller motors, like those used for electronics enclosure cooling fans, are normally single-phase.

### **Polyphase Motors**

The driving torque of ac motors comes from the reaction of current-carrying conductors in a magnetic field. In induction motors, the rotor currents are supplied by electromagnetic induction. The 3-phase stator windings (coils) receive power from the external source via a controller. They produce a continuously rotating magnetic field at constant speed (synchronous), regardless of the load on the motor. The rotor is not connected electrically to the power supply. The revolving magnetic field produced by the stator cuts the conductors of the rotor. This induces a voltage in the conductors and causes current to flow. Hence, motor torque is developed by the interaction of the rotor's magnetic

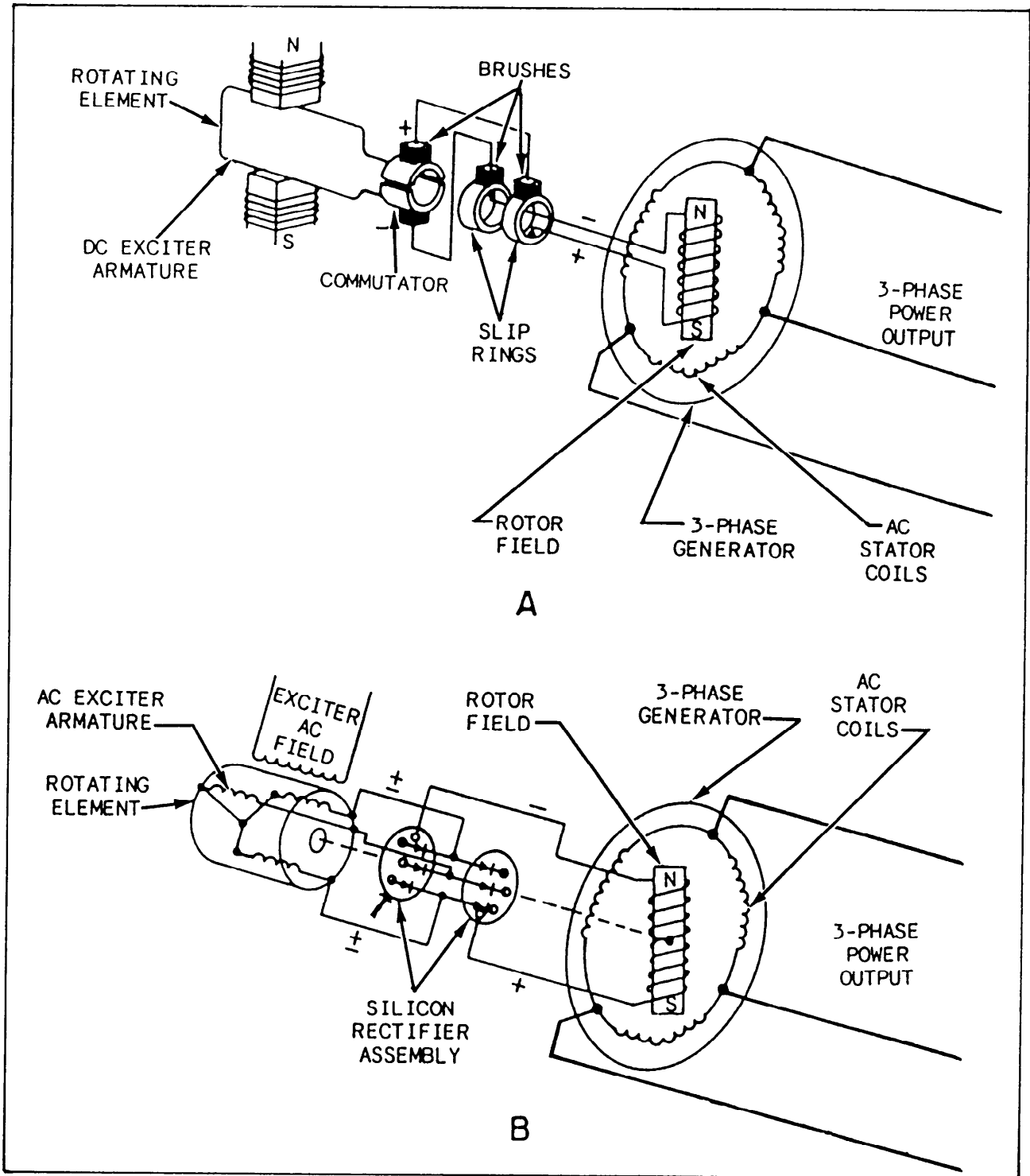

Figure 9-2.—An ac generator. A. Brush type. B. Brushless.

field and the stator's revolving magnetic field. Figure 9-3 shows the parts of a typical polyphase (3-phase) induction motor.

Many other components of the 3-phase motor are used for cooling, support, balancing, and protection of the motor. Ball bearings support the rotor and provide for low friction loss. Balancing disks are used to balance the rotor. Rotor fans are normally provided to cool the motor with air

from the air inlets in the end bells. Vertically mounted motors usually have a drip-proof cover over the top to prevent moisture from entering the housing.

### Single-phase motors

Single-phase motors operate on a single-phase power supply. These motors are used extensively

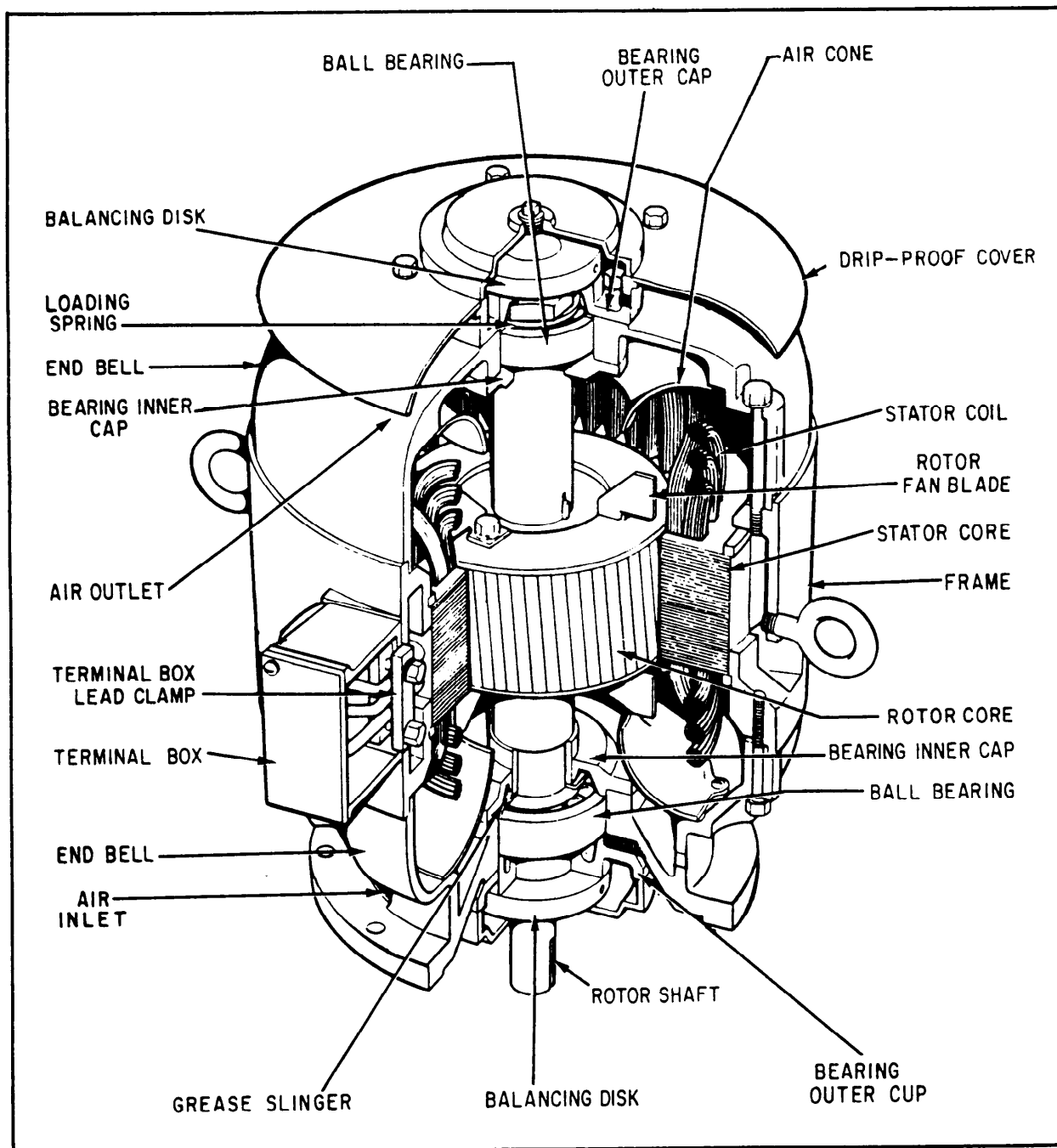

Figure 9-3.—Typical 3-phase induction motor.

in fractional horsepower sizes in commercial and domestic applications. The advantages of using single-phase motors in small sizes are that they are less expensive to manufacture than other types, and they eliminate the need for 3-phase ac lines. Single-phase motors are used in electronic equipment, fans, refrigerators, portable drills, grinders, and so forth.

A single-phase induction motor with only one set of stator windings and a cage rotor is similar to the 3-phase induction motor with a cage rotor. The single-phase motor has no revolving magnetic field at start; therefore, no starting torque. However, the rotor can be brought up to speed by special design of the stator winding. Then the induced currents in the rotor will cooperate with the stator currents to produce a revolving field. This causes the rotor to continue to run in the start direction.

The identification of single-phase motors is determined by the different methods starting torque is provided. These methods are split-phase, capacitor, or universal.

**SPLIT-PHASE MOTOR.**—The split-phase motor (fig. 9-4) has a stator composed of slotted laminations. The stator has an auxiliary (starting) winding and a running (main) winding (fig. 9-4, view A). The axes of these two windings are displaced by an angle of 90 electrical degrees. The starting winding has fewer turns and smaller wire than the running winding; hence, the starting winding has higher resistance and less reactance. The main winding occupies the lower half of the slots. The starting winding occupies the upper half (fig. 9-4, view B). The two windings are connected in parallel across the single-phase line that supplies the motor. The motor gets its name from the action of the stator during the starting period.

At start, these two windings produce a magnetic revolving field. This rotating field rotates around the stator at synchronous speed. As it moves around the stator, it cuts across the rotor conductors and induces a voltage in them. This voltage is maximum in the area of highest field intensity. Therefore, it is in phase with the stator field. The rotor current lags the rotor voltage at start by an angle that approaches 90 degrees because of the high rotor reactance. The interaction of the rotor currents and the stator field causes the rotor to accelerate in the direction in which the stator field is rotating. During acceleration, the rotor voltage, current, and reactance are reduced. The rotor currents come closer to an inphase relation with the stator field.

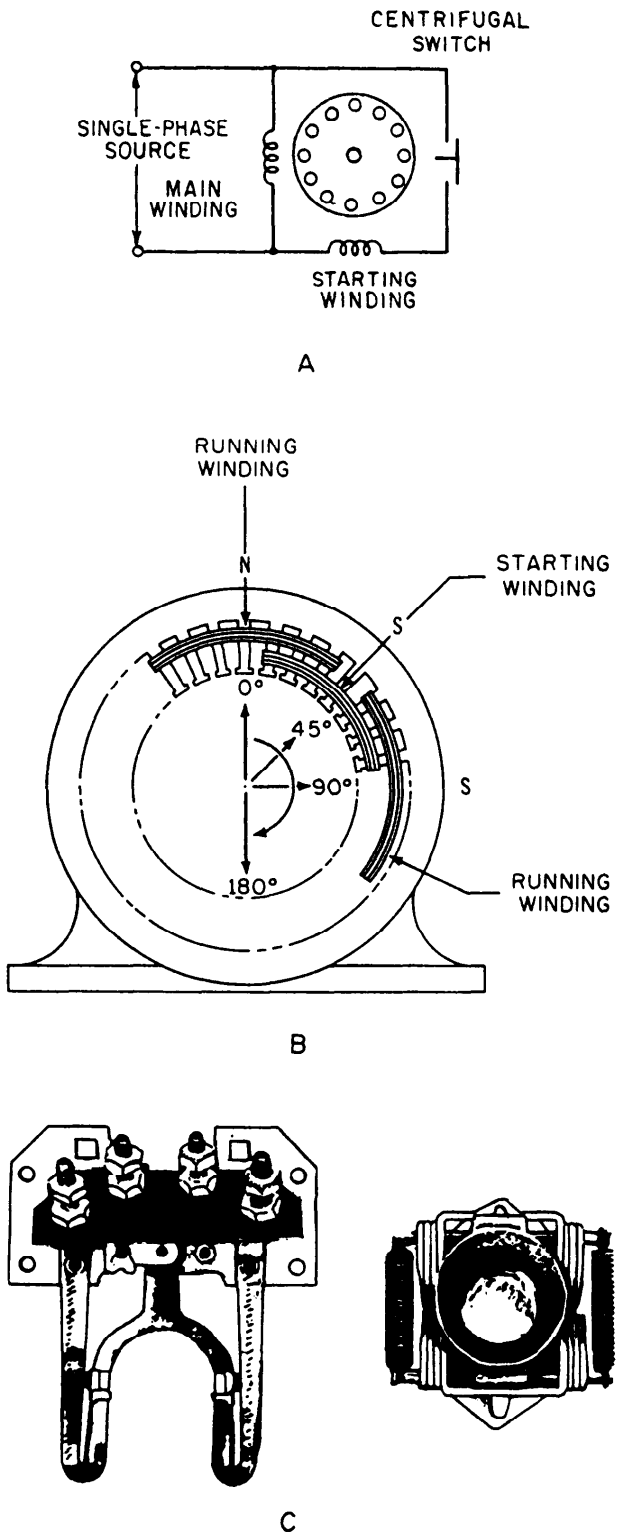

Figure 9-4.— Split-phase motor. A. Circuit diagram. B. Winding configuration. C. Centrifugal switch.

When the rotor reaches about 75 percent of synchronous speed, a centrifugally operated switch (fig. 9-4, view C) disconnects the starting winding from the line supply. The motor continues to run on the main winding alone. Then the rotating field is maintained by the interaction of the rotor and stator electromagnetic forces.

**CAPACITOR MOTOR.**—The capacitor motor is single-phase and has a capacitor in series with the starting winding. An external view is shown in figure 9-5 with the capacitor located on top of the motor. The capacitor produces a greater phase displacement of currents in the starting and running windings than is produced in the split-phase motor. The starting winding in the capacitor motor has many more turns of larger wire than the split-phase motor. The starting winding is connected in series with the capacitor. The starting winding current is displaced about 90 degrees from the running winding current. The axes of the two windings are also displaced by an angle of 90 degrees. Therefore, a higher starting torque is produced than that in the split-phase motor. The starting torque of the capacitor motor may be as much as 350 percent of the full-load torque.

**UNIVERSAL MOTOR.**—A universal motor can be operated on either dc or single-phase ac. Aboard Navy ships, they are used extensively for portable tools. The motor is constructed with a

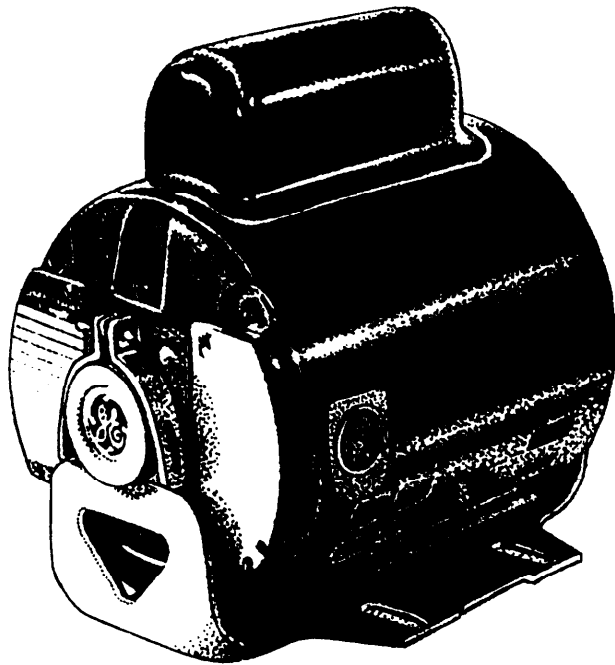

Figure 9-5.—Capacitor motor.

main field connected in series with an armature. The armature is similar in construction to any dc motor. When electric power is applied, the magnetic force created by the fields reacts with the magnetic field in the armature to cause rotation.

## 60-HERTZ DISTRIBUTION SYSTEM COMPONENTS

After the 450-volt, 60-Hz power is generated by an SSDG or an SSGTG, the power must be distributed throughout the ship. Distribution is accomplished by the use of SWBDs, CBs, power panels, automatic bus transfer (ABT) switches, manual bus transfer (MBT) switches, transformers, and cables.

Although each class ship has items peculiar only to that class, operation of switchboards is fairly common for all 60-Hz systems. You must always use EOSS when operating the 60-Hz switchboards. You will undergo extensive shipboard training using PQS to qualify as an electrical watch stander.

## SWITCHBOARDS AND PANELS

A switchgear group is a single section or several sections of switchboard mounted near each other. Switchgear groups are connected together with cabling and disconnect links. They are enclosed in a sheet-steel enclosure from which only handles, knobs, and meters protrude. No live contacts are externally exposed on any switchboard on a gas turbine ship. The sections are identified with a number and letter designation. When discussing the entire switchgear group, the designation is its number followed by the abbreviation *SG*. Each section is identified by its number followed by *S* or *SA* for the control section and *SA* or *SB* for the distribution sections. On the FFG-7 class ship, each SWBD has two sections. The *SA* is the control section; the *SB* is used for distribution breakers. On the larger gas turbine ships, the *SG* is composed of three sections. The control section is the *S* section; the distribution breakers are on the *SA* and *SB* sections.

Example:

FFG-7—No. 1 SSDG feeds the 1SG group composed of 1SA and 1SB.

DDG, DD, CG—No. 2 SSGTG feeds the 2SG group composed of 2S, 2SA, and 2SB.

The control section controls the generator's output. The distribution section distributes power to the different loads on the ship.

Switchboard bus bars (fig. 9-6) are heavy, rugged copper or aluminum bars. They distribute the power within the SWBD. They are used because they can carry the large current loads found in the SWBD.

Current between SWBD sections is also very high. Large cables are used to connect these sections. Since there are no CBs between sections, you have to use some device to isolate a section after a casualty. Disconnect links are used for this purpose. These devices are connected to the bus

bars and interconnecting cable ends and can carry the bus current. One disconnect link is used on each phase.

### WARNING

NEVER OPEN OR CLOSE DISCONNECT LINKS ON AN ENERGIZED SWITCHBOARD.

### Control Section

The control section contains controls and instruments required to control the generator's

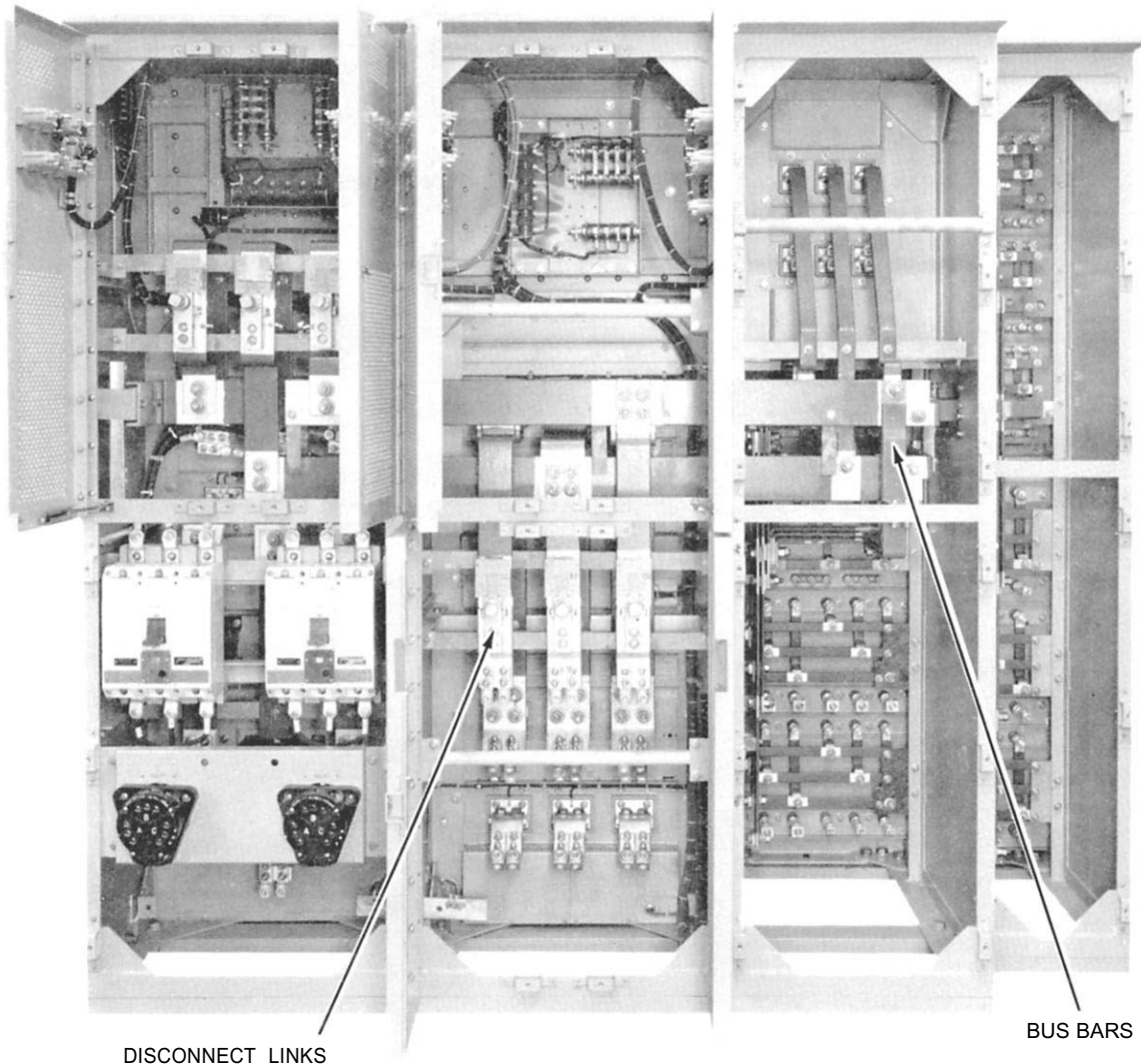

Figure 9-6.—Rear view of a switchboard showing bus bars.

27.353



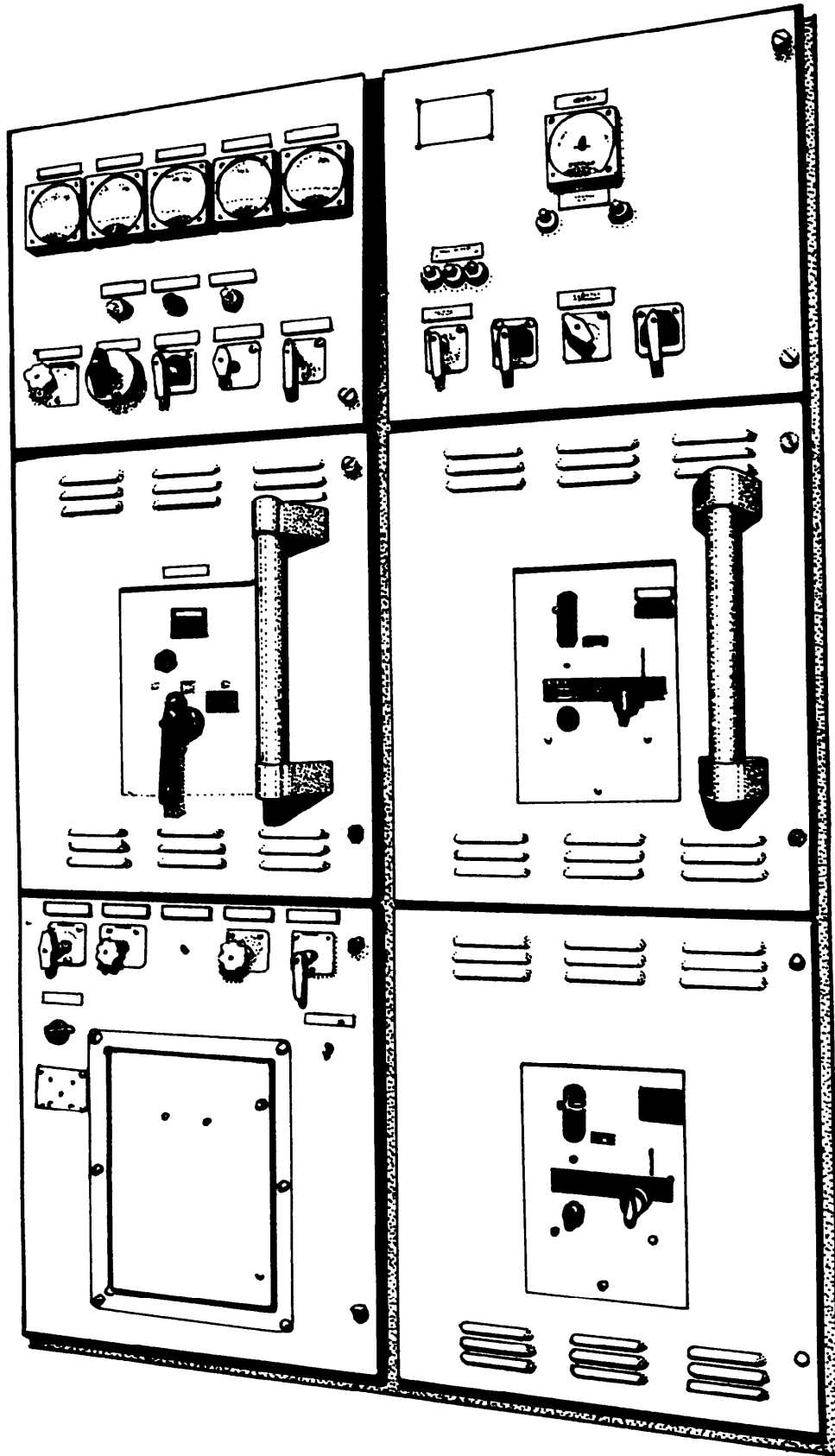

Figure 9-7.—Control section, front view.

output. Figure 9-7 shows the control section of an FFG-7 class ship SWBD. The upper two panels contain meters and switches. The middle two panels contain the generator CB and the bus tie CBs. The other lower section contains the

automatic paralleling device (APD). On the back side of the control section you will find fuses for the control circuits and meter circuits. Other devices on the back side are the CBs for the seawater circulating pump and the casualty power terminal (fig. 9-8).

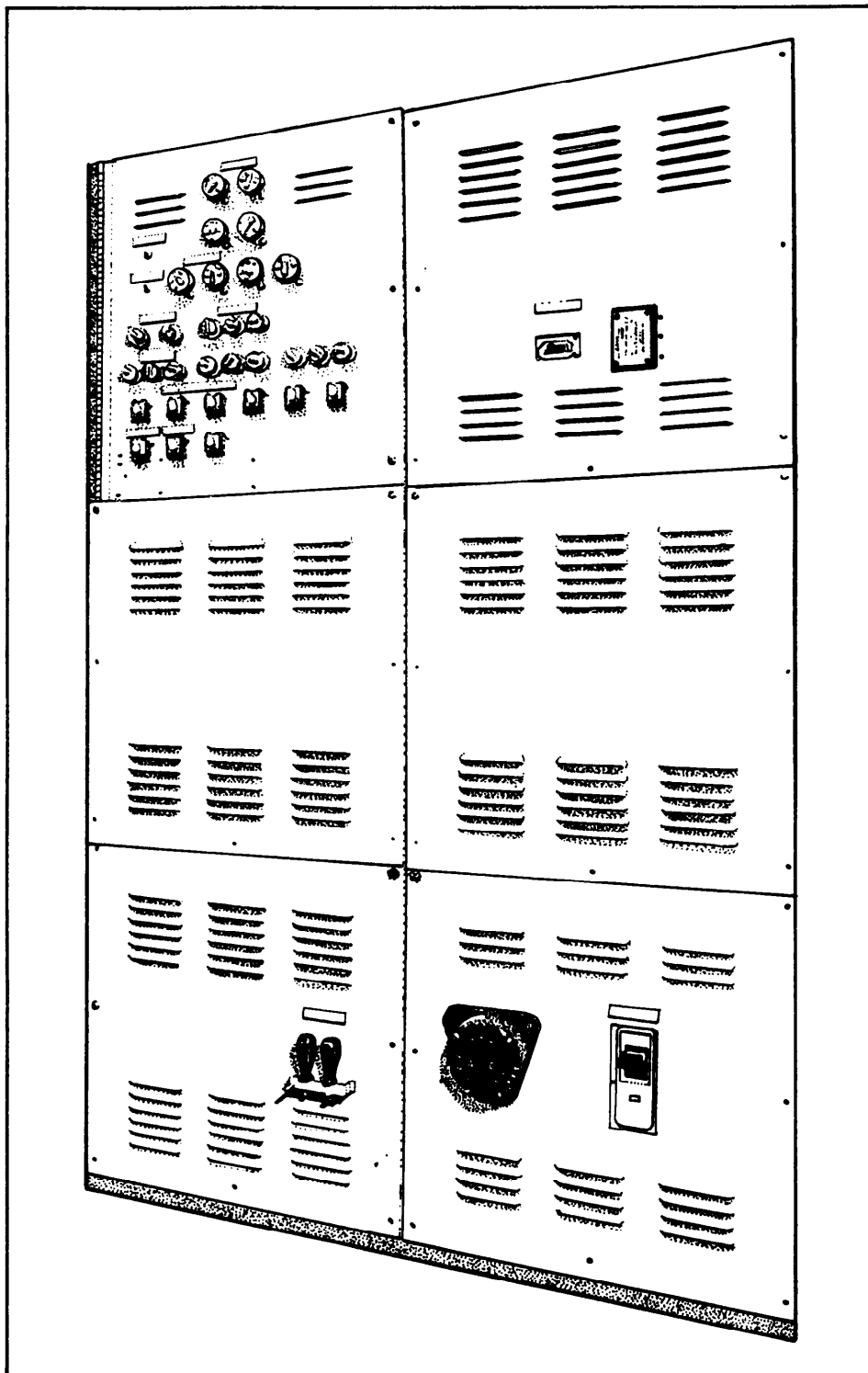

Figure 9-8.—Control section, back view.

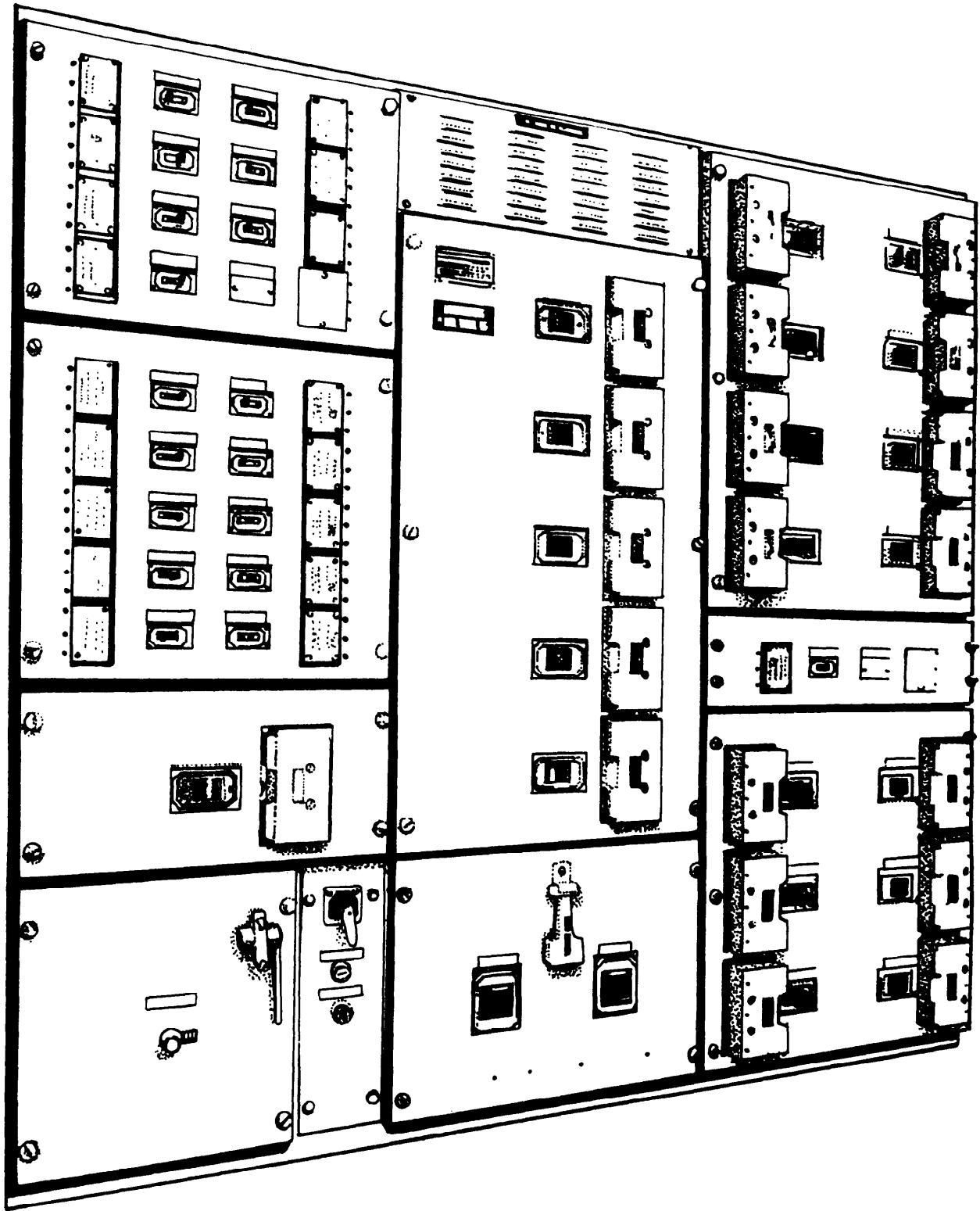

Figure 9-9.—Distribution section.

## Distribution Section

The distribution section contains all the CBs through which the power is distributed to the various power panels or individual equipment. Figure 9-9 shows an example of the distribution section.

## Power Panels

Power panels are located throughout the ship to distribute power to the ship's loads. You can find different numbers of circuits in a panel, up to as many as 16. Vital power panels are fed via ABTs. This allows the panel to be fed from either of two sources. Loads on power panels can include motors, heaters, electronics, and distribution panels. Some of the distribution panels are fed by a transformer bank, which is used to reduce the voltage from 450 volts to 115 volts for lighting distribution panels. The lighting

panels may feed fuse boxes that supply smaller loads or receptacles.

## Shore Power

A means of supplying electrical power to a ship from an external source is known as shore power. The installation of shore power requires a shore-power station, plugs, and connecting cables. The number of cables required will differ with each class of ship.

A shore-power station (fig. 9-10, view A) is located at or near a suitable weather deck location, to which portable cables can be attached from shore or a ship alongside. The same station can be used to supply power from the ship to a ship alongside. The shore-power station has a receptacle assembly arranged as shown in figure 9-10, view B.

A shore-power plug is installed on the end of shore-power cables for ease of making the

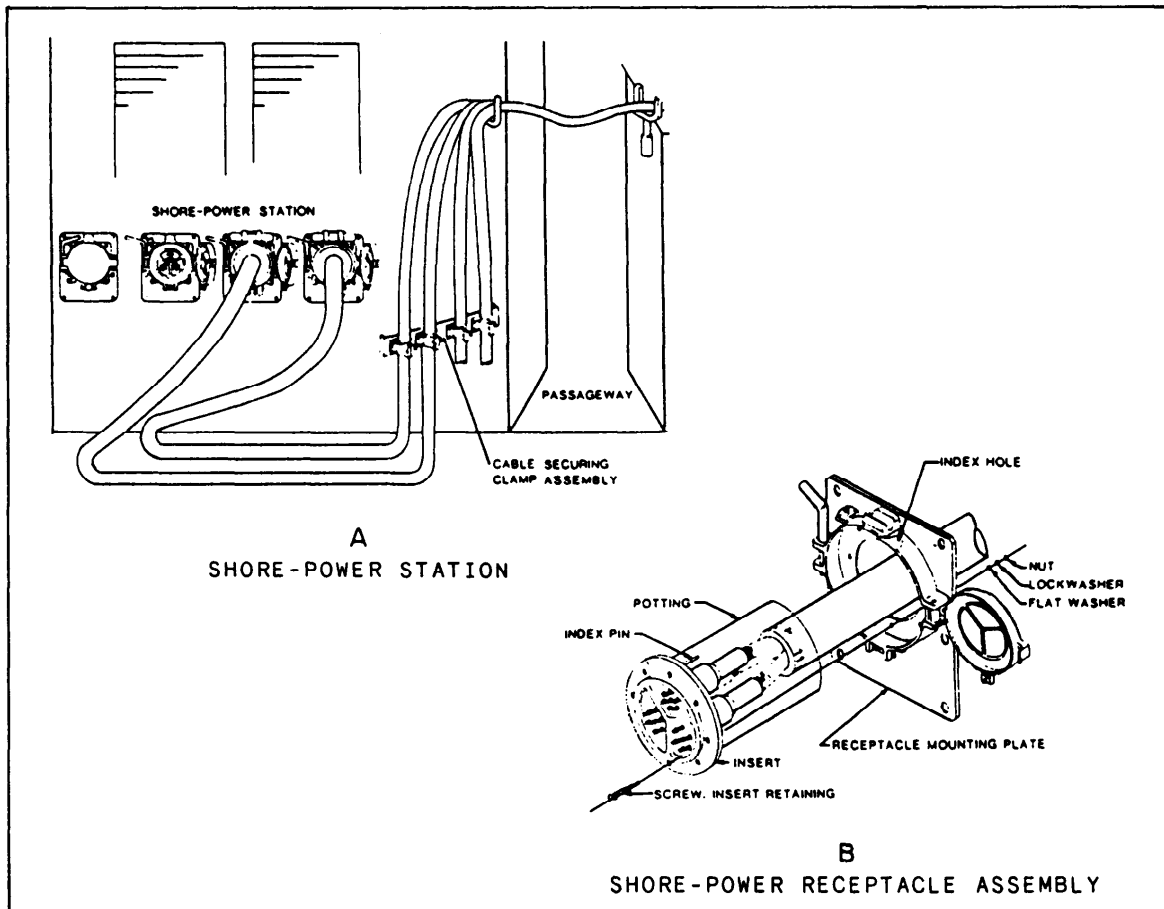

Figure 9-10.—Shore-power station and receptacle assembly.

shore-power connection. Figure 9-11 shows a shore-power plug. Personnel injury and equipment damage can be avoided when shore-power cables and fittings are inspected before shore-power connections are made.

### Circuit Breakers

The purposes of a CB are to provide switching operation, circuit protection, and circuit isolation.

Air CBs are used in SWBDs, switchgear groups, and distribution panels. The types installed on naval ships are ACB, AQB, AQB-A, AQB-LF, NQB-A, ALB, and NLB. They are called air CBs because the main current-carrying contacts interrupt in air.

Circuit breakers are available in manually or electrically operated types. Some types may be operated both ways, while others are restricted to one mode. They may or may not be provided with protective functions. The differences and uses of the various types of CBs are described in the following sections.

**ACB.**—The ACB type of CB may be either manual (local) closing or electrical (remote) closing. It has an open metallic frame construction mounted on a drawout mechanism and is normally used where heavy load and high short-circuit currents are available. Figure 9-12 shows the external view of a type ACB circuit breaker.

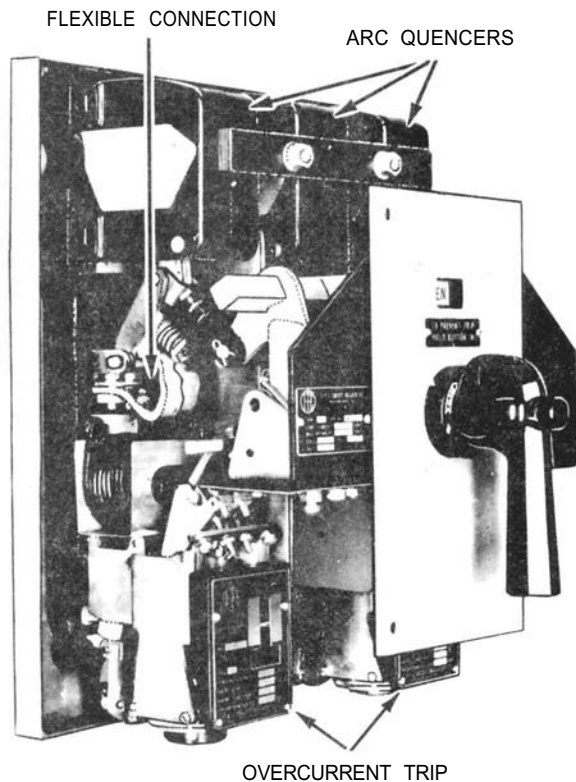

Figure 9-12.—Type ACB circuit breaker.

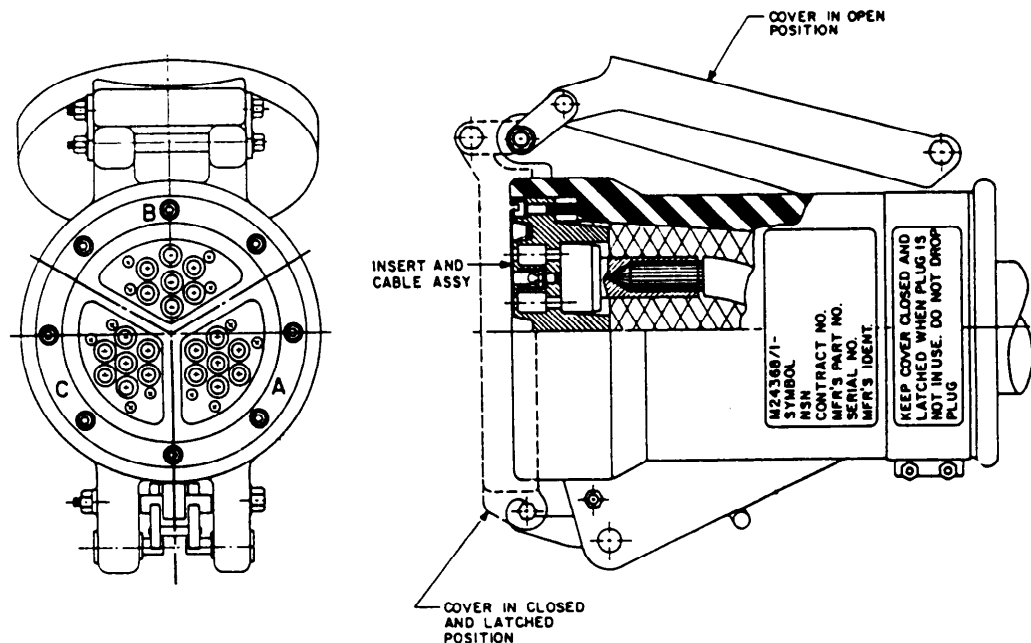

Figure 9-11.—Shore-power plug.

Type ACB circuit breakers are used to connect ship's service generators to the power distribution system and bus ties.

When a CB is used to connect ship's service generators to the SWBD, they must have a reverse power relay installed. The reverse-power relay is mounted on a panel close to the CB. Other automatic controls may be located at remote points to give maximum protection to the circuit.

Circuit breakers designed for high currents have a double-contact arrangement. The complete contact assembly consists of the main bridging contacts and the arcing contacts. Current-carrying contacts are constructed of high-conductivity, arc-resisting, silver-alloy material, which is bonded to the contact surface for durability and longer wear.

Each contact assembly has a means of holding the arcing to a minimum and of extinguishing the

arc as soon as possible. The arc control section contains an arc chute. The contacts are so arranged that when the circuit is closed, the arcing contacts close first. Proper pressure is maintained by springs to be sure the arc contacts close first. The main contacts then close.

When the circuit opens, the main contacts open first. The current is then flowing through the arc contacts, which prevents burning of the main contacts. When the arc contacts open, they pass under the front of the arc runner. This causes a magnetic field to be set up, which blows the arc up into the arc chute and quickly extinguishes the arc.

**AQB.**—Type AQB circuit breakers, such as the AQB-250 shown in figure 9-13, view A, are mounted in supporting and enclosing housings of

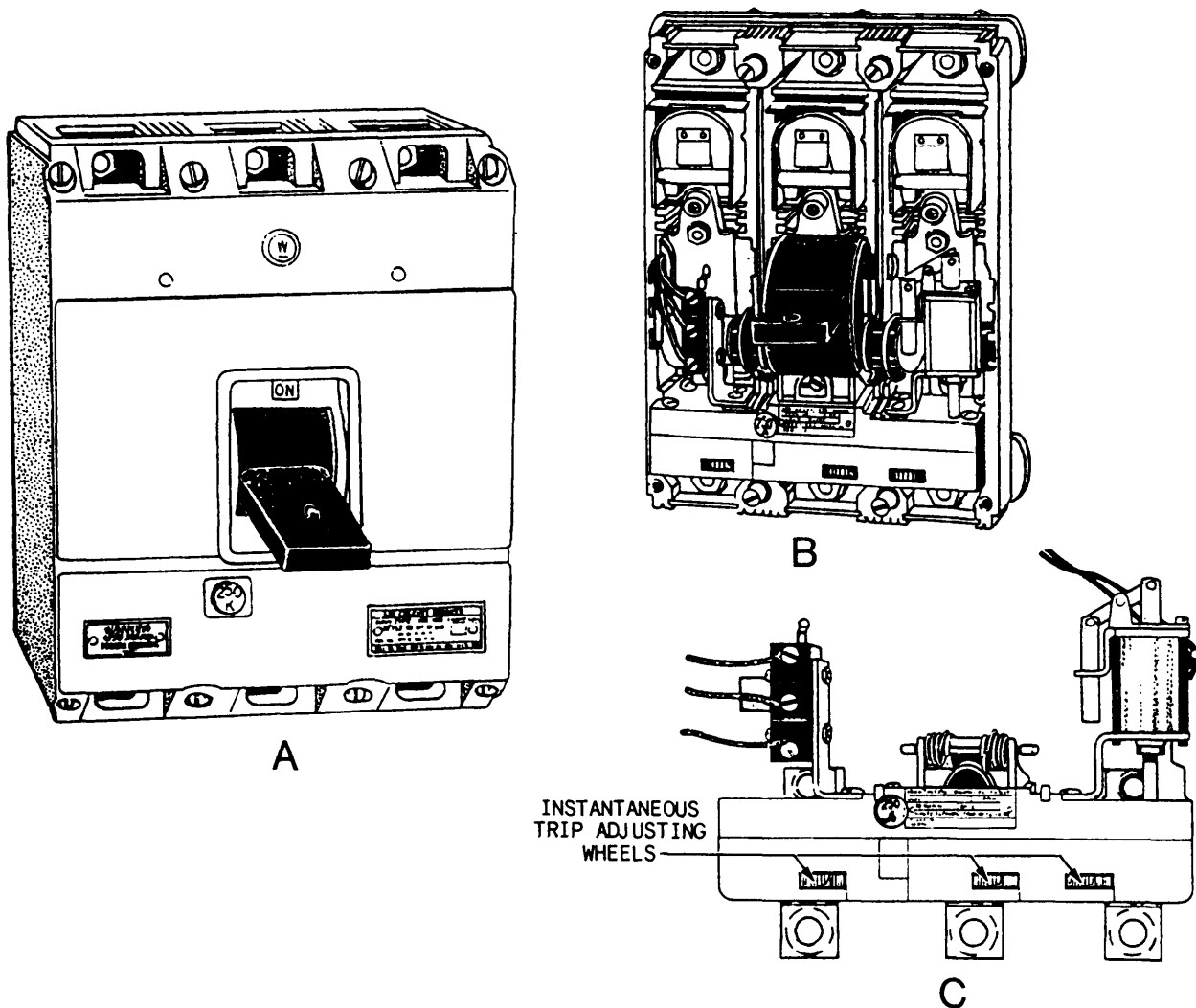

Figure 9-13.—AQB-A250 circuit breaker. A. Front view. B. With cover removed. C. Shunt trip.

insulating material and have direct-acting automatic tripping devices. They are used to protect single-load circuits and feeder circuits coming from a load center or distribution panel.

The outside dimensions of these breakers are the same for both the two-pole dc CB and three-pole ac CB. They are designed for front or rear connections. They may be mounted so they can be removed from the front without removing the CB cover.

The frame size of the CB is designated by the 250. In a 250-ampere frame size CB, the current-carrying parts of the breaker have a continuous rating of 250 amperes. Trip units for this breaker (fig. 9-13, view B) are available with current ratings of 125, 150, 175, 225, and 250 amperes.

The trip unit houses the electrical tripping mechanisms, the thermal element for tripping the CB on overload conditions, and the instantaneous trip for tripping on short-circuit conditions.

The automatic trip devices of the AQB-A250 circuit breaker are trip-free. In other words, the CB cannot be held closed by the operating handle if an overload exists. When the CB has tripped due to overload or short circuit, the handle rests approximately in a center position. To reclose the CB after automatic tripping, move the handle to the extreme OFF position. This resets the latch

in the operating mechanism. Then move the handle to the ON position.

The AQB-A250 circuit breaker may have auxiliary switches or shunt trip (for remote tripping) attachments. Figure 9-13, view C, shows a shunt trip. The instantaneous trip setting of the AQB-A250 trip units may be adjusted by the instantaneous trip adjusting wheels. These trip adjusting wheels can be adjusted to five positions, LO-2-3-4-HI. The trip unit label will list the instantaneous trip value obtainable for each marked position. The settings must be the same on each pole of the CB.

Terminal mounting block assemblies (fig. 9-14) consist of terminal studs in terminal mounting blocks of insulating material. The terminals of the CB have slip-type connectors, which engage the terminal studs as shown in figure 9-14. Two mounting blocks are required for each CB. This method of connecting a CB to a bus or circuit is known as a back-connected CB. Some AQB circuit breakers have solderless connectors attached to their terminals for front-connections.

**AQB-LF.**—The AQB-LF250 circuit breaker (fig. 9-15, view A) combines the AQB circuit breaker features with a current-limiting fuse unit, which interrupts the circuit when the current is more than the interrupting rating of the breaker.

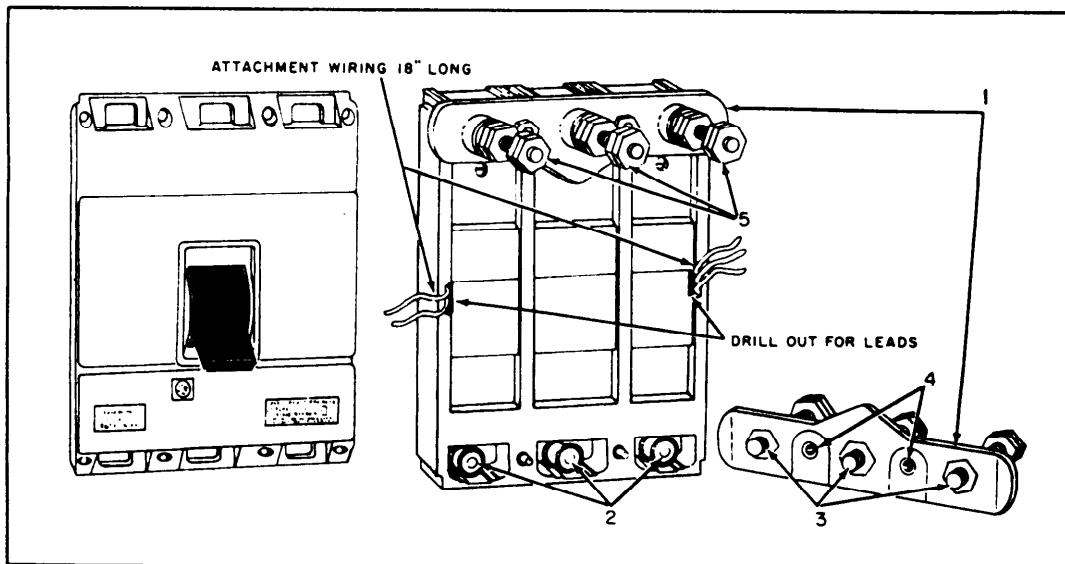

- |  |  |
|--|--|
| <ul style="list-style-type: none"> <li>1. Terminal mounting blocks (2 required)</li> <li>2. Slip-type connectors</li> <li>3. Terminal studs</li> </ul> | <ul style="list-style-type: none"> <li>4. Terminal mounting block inserts for breaker mounting bolts</li> <li>5. Terminal stud nuts</li> </ul> |
|--|--|

Figure 9-14.—AQB-A250 circuit breaker, rear view, with terminal mounting block.

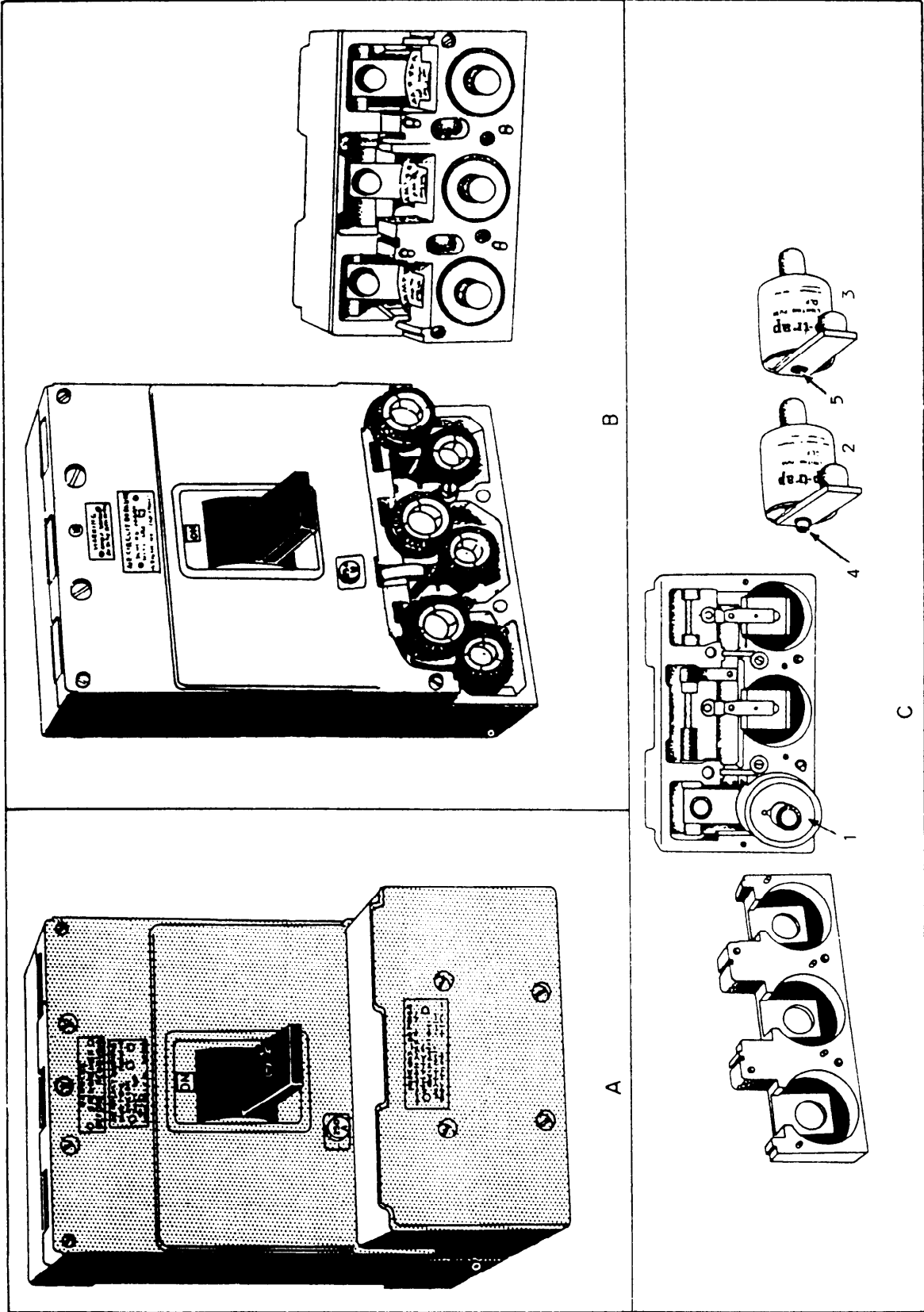

1, 2, and 3. Current limiting fuses 4. Extended plunger of blown fuse 5. Retracted plunger of unblown fuse

Figure 9-15.—AQB-LF250 A. Front view with fuse unit removed. B. Front view with fuse unit removed. C. Current-limiting fuse unit.



Constructed as one compact unit, the AQB-LF circuit breaker includes the current-limiting fuses (fig. 9-15, view B) as integral parts of the CB. The trip units and trip features in the AQB-LF circuit breaker are the same as those in the AQB-A250 circuit breakers.

The current-limiting fuse unit is designed to trip the breaker and open all poles if any current-limiting fuse (fig. 9-15, view C) blows. After a fuse blows, the CB cannot be reclosed until the blown fuse is replaced. Any attempt to remove the fuse unit causes the CB to automatically go to the trip position.

The AQB-LF250 circuit breaker is mechanically interchangeable with the AQB-A250 circuit breaker, except a larger cutout is required in the SWBD front panel to accommodate the fuse unit of the AQB-LF250.

The AQB-LF250 circuit breaker is a 250-ampere frame size. However, the CB has an interrupting rate of 100,000 amperes at 500 volts ac, 60 Hz. The AQB-A250 circuit breaker has an interrupting rating of 20,000 amperes at 500 volts ac, 60 Hz.

While the AQB-A250 circuit breaker can be either front or back connected, the AQB-LF250 is designed only for back (drawout type) connection. It uses the same type of slip connectors and terminal studs as shown in figure 9-14.

**NQB.**—The NQB-A250 circuit breaker is similar to the AQB-A250 circuit breaker, except the NQB-A250 has no automatic tripping devices. This CB is used for circuit isolation and manual transfer applications. The NQB-A250 is a 250-ampere frame size. The current-carrying parts of the breaker are capable of carrying 250 amperes. Technically, this CB is simply a 250-ampere on-and-off switch.

**ALB.**—The ALB circuit breakers are designated low-voltage, automatic CBs. The continuous duty rating ranges from 5 to 200 amperes at 120 volts ac or dc. The breaker is provided with a molded enclosure, drawout type of connectors, and nonremoveable and non-adjustable thermal/magnetic trip elements.

This CB is a quick-make, quick-break type. After the CB trips, before resetting it, you must place the handle in the OFF position.

**NLB.**—The NLB circuit breakers are just like the ALB circuit breakers, except that they have no automatic tripping device. They are used only as on-off switches.

## POWER DISTRIBUTION COMPONENTS

Many components of the 60-Hz distribution system are located throughout the ship to

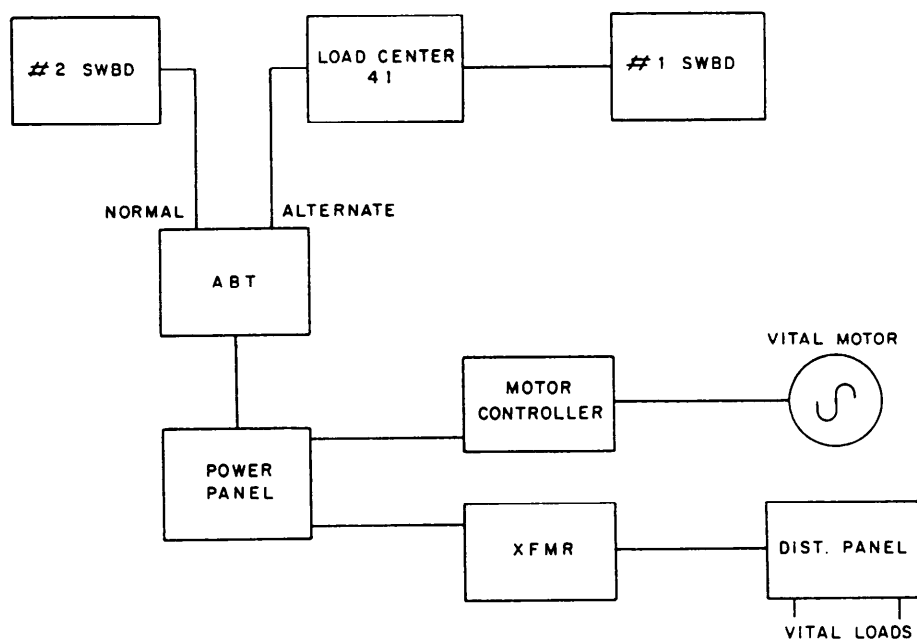

Figure 9-16.—Typical 60-Hz vital circuit using the ABT.

provide isolation, switching, and distribution. These components include ABTs, MBTs, and transformers. This equipment routes power from the SWBD to the loads. Some equipment protects the distribution system from casualties in the loads; other equipment transforms and switches the power to send it to the load. In the following sections, we will discuss these components and the protective features they add to the entire distribution system.

### Automatic Bus Transfers

An ABT is an electromechanical device that automatically switches power sources from

normal to alternate if the normal source fails. Power is fed through an ABT to most of the vital equipment on board ship. The normal and alternate sources of power for an ABT are fed from two independent sources of power. They are never fed by two sources from the same SWBD. Figure 9-16 is a line diagram of a typical vital circuit from the SWBD to the load. Lighting in vital areas are also fed via ABTs.

The model A-2 ABT unit is designed to handle small loads. It operates on 120-volt, 60-Hz circuits. This unit (fig. 9-17) may be used on single- or 3-phase circuits. For purposes of explanation, the 3-phase unit will be discussed.

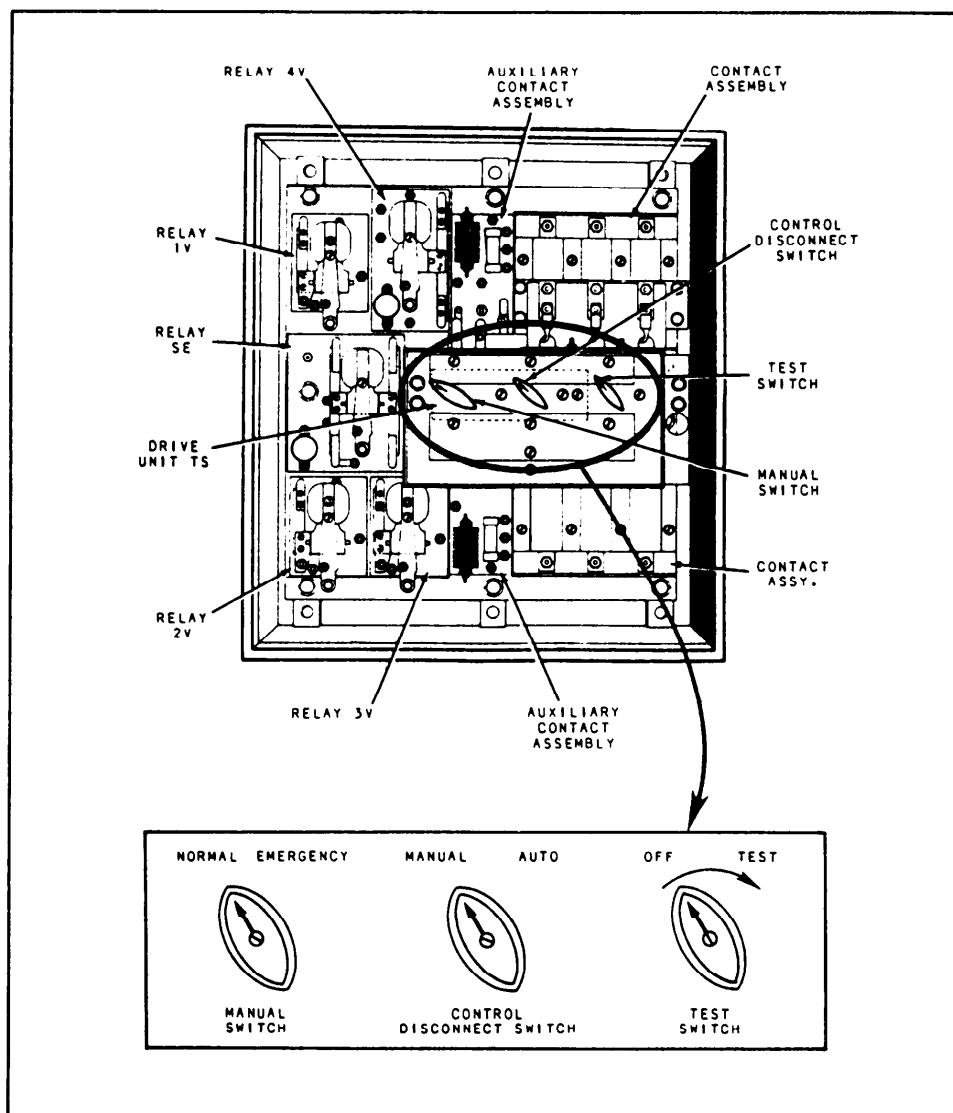

Figure 9-17.—A pictorial view of an ABT.

The ABT is designed to transfer automatically from normal to alternate supply. It does this upon a decrease in voltage across any two of its three phases. Upon restoration of the voltage, the unit is adjusted to retransfer to the normal source of supply.

The ABT unit shown in figure 9-17 is equipped for manual operation. To manually operate the ABT, place the control disconnect switch in the manual position and operate the manual switch. When in AUTO, test the automatic operation of the ABT by turning the spring-loaded test switch to the test position.

You must be careful when testing the ABT units to ensure they do not include in their load vital and sensitive electronic circuitry that will be adversely affected by the loss and almost instant return of power. You must ensure all other groups are adequately informed of power supply system tests to be performed.

### Manual Bus Transfers

The MBTs are devices located within power panels that enable manual shifting from normal to alternate power. The MBTs are used on loads that are vital but do not require automatic recovery upon loss of power. An example of a circuit with an MBT would be engine-room ventilation power. While it is desirable to have ventilation all the time, its loss for a short time would not adversely affect plant operation. When time permits, an operator can switch the MBT and restart the vent fans.

Most MBTs are built into the power panels they serve. They are constructed of two CBs with some type of mechanical safety interlock. Indicator lights are also provided to show the sources of power available. The CBs are type NQB or CBs without trip elements.

The mechanical interlock is usually a movable bar that prevents closing both CBs at the same time. **NEVER TAMPER WITH OR BYPASS THE INTERLOCK ON AN MBT.** If both source breakers are closed at the same time, severe damage could result. If you are operating the electric plant in split-plant mode, you could end up paralleling the ship's load across cables and breakers rated much lower than the bus tie capacity.

The following is the correct procedure for you to use when shifting an MBT from normal to alternate power.

1. Be sure the alternate power indicator lamp is on, showing that power is available.

2. Open the normal power CB.
3. Shift the interlock to prevent closure of the normal power breaker and enable closure of the alternate power breaker.
4. Close the alternate power CB.

**NOTE:** If you are shifting MBTs while power is available on both sources, you should obtain permission from the EOOW before starting the procedure. Failure to do so could cause loss of equipment that is on the line.

### Transformers

A transformer is a device that has no moving parts. It transfers energy from one circuit to another by electromagnetic induction. The energy is always transferred without a change in frequency. Usually there are changes in voltage and current. A step-up transformer receives electrical energy at one voltage and delivers it at a higher voltage. Conversely, a step-down transformer receives energy at one voltage and delivers it at a lower voltage. Transformers require little care and maintenance because of their simple, rugged, and durable construction. The efficiency of transformers is high. Because of this, transformers are responsible for the more extensive use of ac than dc. The conventional constant-potential transformer operates with the primary connected across a constant-potential source. It provides a secondary voltage that is substantially constant from no load to full load.

Various types of small single-phase transformers are used in electrical equipment. In many installations, transformers are used on SWBDs to step down the voltage for indicating lights. Low-voltage transformers are included in some motor control panels to supply control circuits or to operate overload relays.

Instrument transformers include potential, or voltage, transformers and current transformers (CTs). Instrument transformers are commonly used with ac instruments when high voltages or large currents are to be measured.

The power-supply transformer used in electronic circuits is a single-phase, constant-potential transformer. It has one or more secondary windings, or a single secondary with several tap connections. These transformers have a low volt-ampere capacity. They are less efficient than large constant-potential power transformers.

The typical transformer: has two windings insulated electrically from each other. These windings are wound around a common magnetic core made of laminated sheet steel. The principal

parts are (1) the core, which provides a circuit of low reluctance for the magnetic flux; (2) the primary winding, which receives the energy from the ac source; (3) the secondary winding, which receives the energy by mutual induction from the primary and delivers it to the load; and (4) the enclosure.

When a transformer is used to step up the voltage, the low-voltage winding is the primary. Conversely, when a transformer is used to step down the voltage, the high-voltage winding is the primary. The primary is always connected to the source of the power; the secondary is always connected to the load. It is common practice to refer to the windings as the primary and secondary rather than the high-voltage and low-voltage windings. For more information on the construction and installation of transformers, refer to the *Electrician's Mate*, NAVEDTRA 12164.

### POWER PANELS AND CABLE MARKINGS

Some method must be used to locate power panels and the equipment that is fed. Also, switchboards must have markings on the breakers to identify what circuits or equipment are fed. The Navy uses a standard system to identify the location and source of power for all switchboards, panels, and loads. This system uses the deck/frame/side location that identifies other shipboard components. The system is also used on cables to identify their power source.

The first part of the designation you see identifies the switchboard or load center that supplies the power. This could be numbers or a letter/number combination. The following is an example of some markings you may find and what the first number means.

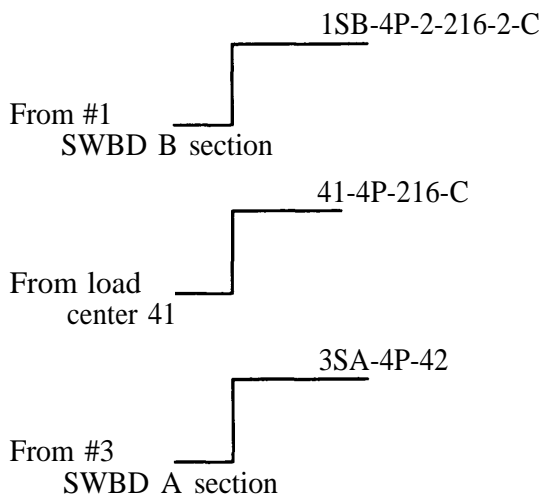

The second designation will tell you the voltage potential and the use of the power. The most common voltages used are 115 volts, designated by a number 1, and 450 volts, designated by number 4. The number is actually the range the voltage falls into, such as follows:

| DESIGNATOR | VOLTAGE RANGE |
|------------|---------------|
| 1          | 100 to 199    |
| 2          | 200 to 299    |
| 3          | 300 to 399    |
| 4          | 400 to 499    |

The letter part of the designation shows the use of the power. The most common ones are as follows:

| DESIGNATOR | FEEDER                         |
|------------|--------------------------------|
| K          | Control, power plant, and ship |
| C          | Interior communications        |
| EL         | Emergency lighting             |
| L          | Lighting                       |
| CP         | Casualty power                 |
| P          | Ship's service power           |
| WP         | Weapon's power                 |

Other letters and symbols are used with these basic letters to form the complete cable designation. This gives the cable's source, service, and designation. Typical markings for power system cables from a generator to a load and the meanings of the symbols are as follows:

#### 1. Generator cables: 2SG-4P-2S

2SG—Fed from ship's service (SS) generator No. 2

4P—450-volt power cable

2S—Supplying SS switchgear group No. 2

2. Bus feeder: 2S-4P-31
  - 2S—Fed from SS switchgear group No. 2
  - 4P—450-volt power cable
  - 31—Supplying load center SWBD No. 31
3. Feeder: 31-4P-(3-125-2)
  - 31—Fed from load center SWBD No. 31
  - 4P—450-volt power cable
  - (3-125-2)—Supplying power distribution panel located on third deck, frame 125, port side
4. Main: (3-125-2)-4P-C
  - (3-125-2)—Fed from power distribution panel located on third deck, frame 125, port side
  - 4P—450-volt power cable
  - C—Indicates this is the third cable from the panel, fed by breaker C
5. Submain: (3-125-2)-1P-C1
  - (3-125-2)—Fed from power distribution panel located on third deck, frame 125, port side
  - 1P—120-volt power cable
  - C1—Indicates first cable fed (through a transformer) by the main
6. Branch: (3-125-2)-1P-C1B
  - (3-125-2)—Fed from power distribution panel located on third deck, frame 125, port side
  - 1P—120-volt power cable
  - C1B—Indicates second cable fed by the submain
7. Subbranch: (3-125-2)-1P-C1B2
  - (3-125-2)—Fed from power distribution panel located on third deck, frame 125, port side
  - 1P—120-volt power cable
  - C1B2—Indicates second cable fed by the branch

## MOTOR CONTROLLERS

Motor controllers function to start a motor, to stop it, or to increase or decrease the speed of a two-speed motor. There are many different types of controllers. In this chapter we will only discuss the most common types used on gas turbine ships.

A **MANUAL** controller is operated directly through a mechanical system. The operator closes and opens the contacts that normally energize and de-energize the connected load.

In a **MAGNETIC** controller, the contacts are closed and opened by electromechanical devices. The devices are operated by local or remote master switches (defined in the next section). Magnetic controllers may be semiautomatic, automatic, or a combination of both. Normally, all the functions of a semiautomatic magnetic controller are governed by one or more manual master switches; those of an automatic controller are governed by one or more automatic master switches. Automatic controllers must be energized initially by a manual master switch. A full and semiautomatic controller can be operated either as an automatic or as a semiautomatic controller.

An **ACROSS-THE-LINE** controller throws the connected load directly across the main supply line. The motor controller may be either a manual or magnetic type. The type depends on the rated horsepower of the motor. Most controllers found on gas turbine ships are magnetic across-the-line controllers.

### Types of Master Switches

A master switch is a device that controls the electrical operation of a motor controller. They can be manually or automatically operated. Drum, selector, and pushbutton switches are examples of manual master switches. The automatic switch functions through the effect of a physical force, not an operator. Examples of automatic master switches include float, limit, or pressure switches.

Master switches may start a series of operations when their contacts are closed or when their contacts are opened. In a momentary contact master switch, the contact is closed (or opened) momentarily; it then returns to its original condition. In a maintaining contact master switch, the contact does not return to its original condition after closing (or opening) until again operated.

## Magnetic Across-the-Line Controllers

A typical across-the-line, 3-phase controller is shown in figure 9-18. Figure 9-19 shows the main contactor assembly. All contactor assemblies are similar in appearance but vary in size. You start the motor by pushing the START button. This action completes the circuit that will energize the main contactor assembly, closing the main contacts connecting the full-line voltage to the motor.

The motor will continue to run until the contactor coil is de-energized. It can be de-energized by the STOP push button, failure of the line voltage, or tripping of the overload relay (OL).

### Two-Speed Control

An ac induction motor for two-speed operation may have a single winding or two separate windings, one for each speed. Pressing the HS push button closes the HS contactor assembly, connecting the high-speed windings to the full-line voltage. Pressing the LS push

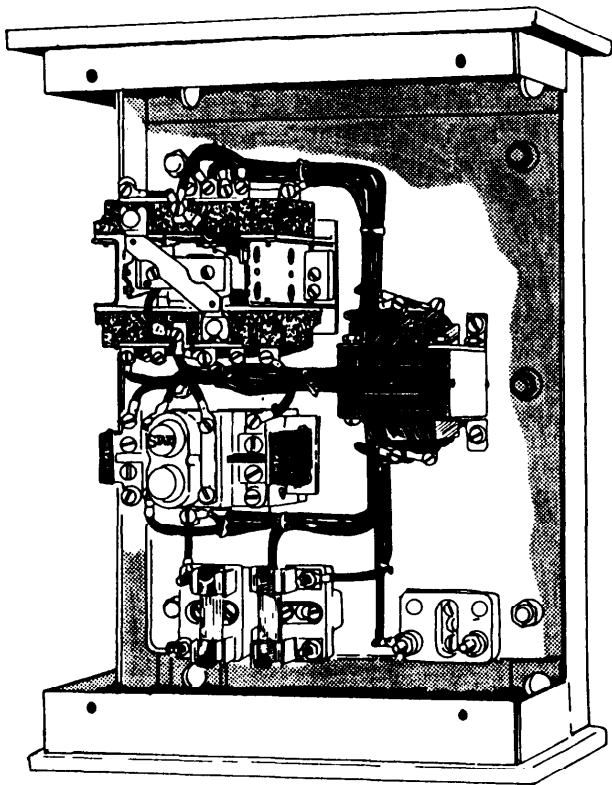

Figure 9-18.—Across-the-line, 3-phase controller.

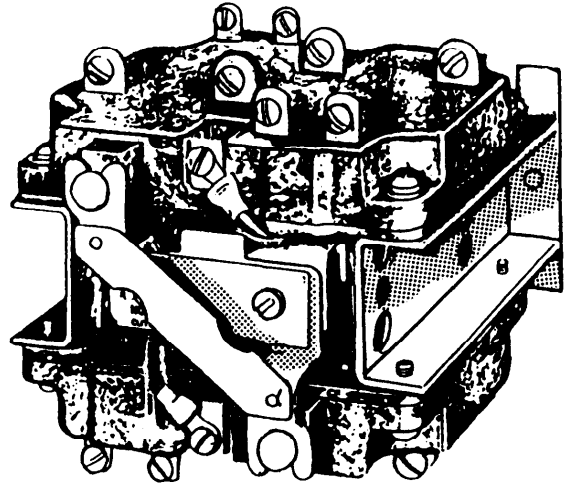

Figure 9-19.—Contactor assembly.

button closes the LS contactor assembly, connecting the low-speed windings to the full-line voltage. The two main contactor assemblies are mechanically interlocked. This prevents both CBs from being closed at the same time. The speed can be changed without stopping the motor. The contactor coil is de-energized and energized in the same manner as the magnetic controller.

### Low-Voltage Protection

With low-voltage protection (LVP), when the supply voltage is reduced or lost, you must restart the controller manually. The master switch is usually a momentary switch.

### Low-Voltage Release

When the supply voltage is reduced or lost altogether, a low-voltage release (LVR) controller disconnects the motor from the power supply. It keeps it disconnected until the supply voltage returns to normal. Then it automatically restarts the motor. This type of controller must be equipped with a maintaining master switch.

### Low-Voltage Release Effect

Most small manual across-the-line controllers have a property known as low-voltage release effect (LVRE). These controllers are switched on to start a motor. When voltage is lost, the motor stops. When voltage returns, since the switch is closed, the motor will restart. Although not truly an LVR controller, since it does restart the motor, it is known as an LVRE.

## Overload Relays

Nearly all shipboard motor controllers provide overload protection when motor current is excessive. This protection is provided by THERMAL or MAGNETIC overload relays. Those relays disconnect the motors from their power supply. This prevents them from overheating.

Overload relays in magnetic controllers have normally closed contacts. The contacts are opened by a mechanical device that is tripped by an overload current. Opening the overload relay contacts breaks the circuit through the operating coil of the main contactor. This causes the main contactor to open, cutting off the power to the motor. Overload relays in manual controllers operate mechanically to trip the main contacts and allow them to open.

**THERMAL OVERLOAD RELAYS.**—The thermal overload relay has a heat-sensitive element. It has an overload heater that is connected in series with the motor load circuit. When the motor current is excessive, heat from the heater causes the heat-sensitive element to open the overload relay contacts. This breaks the circuit through the operating coil of the main contactor. The motor is also disconnected from the power supply. Since it takes time for parts to heat, the thermal overload relay has an inherent time delay. This permits the motor to do maximum work at any reasonable current. It does this only as long as the motor is not being overheated. When it is, the overload relay disconnects the motor.

There are four types of thermal overload relays: solder pot, bimetal, single metal, and induction. The heat-sensitive element of a SOLDER-POT type is a cylinder inside a hollow tube. The cylinder and tube are normally held together by a film of solder. If an overload occurs, the heater melts the solder (this breaks the bond between the cylinder and tube). Then the tripping device of the relay is released. After the relay trips, the solder cools and solidifies. You can then reset the relay.

In the BIMETAL type, the heat-sensitive element is a strip or coil of two different metals. They are fused together along one side. When heated, the strip or coil deflects because one metal expands more than the other. The deflection causes the overload relay contacts to open. The heat-sensitive element of the SINGLE-METAL type is a tube around the heater. The tube

lengthens when heated and opens the overload relay contacts.

The heater in the INDUCTION type has a coil in the motor load circuit and a copper tube inside the coil. The tube acts as the short-circuited secondary of a transformer. It is heated by the current induced in it. The heat-sensitive element is usually a bimetal strip or coil.

**MAGNETIC OVERLOAD RELAYS.**—The magnetic overload relay has a coil connected in series with the motor load circuit and a tripping armature or plunger. When motor current exceeds the tripping current, the armature opens the overload relay contacts. This type of magnetic overload relay operates instantly when the motor current exceeds the tripping current. Another type of magnetic overload relay is delayed a short time when motor current exceeds tripping current. This type is essentially the same as the instantaneous relay except for the time-delay device.

**OVERLOAD RELAY RESETS.**—After an overload relay has operated to stop a motor, it must be reset before the motor can be run again with overload protection. Magnetic overload relays can be reset immediately after tripping. Thermal overload relays must be allowed to cool a minute or longer before they can be reset. The type of overload reset is manual, automatic, or electric.

The manual, or hand, reset is located in the controller enclosure that contains the overload relay. This reset usually has a hand-operated rod, lever, or button that returns the relay tripping mechanism to its original position.

The automatic type of reset, usually a spring- or gravity-operated device, resets the overload relay without the help of an operator. The electric reset is operated by an electromagnet controlled by a push button. This form is used when it is desired to reset an overload relay from a remote operating point.

**SHORT CIRCUIT PROTECTION.**—Overload relays and contactors are usually not designed to protect motors from currents greater than about six times the normal rated current of ac motors. Since short-circuited currents are much higher, protection against short circuits in motor controllers is obtained through other devices. Navy practice is to protect against these short circuits with CBs placed in the power supply system. In this way, both the controller and motor are protected. The cables connected to the

controller are also protected. However, sometimes short circuit protection is provided in the controller. This is done in cases where it is not otherwise provided by the power distribution system. Short circuit protection for control circuits is provided by fuses in the controller enclosure.

## **UNINTERRUPTIBLE POWER SUPPLY**

Periodically a gas turbine ship experiences a partial or total loss of 60-Hz ship's service power to engineering equipment requiring a constant power source. The equipment may be a control console, a SWBD, or a GTE. Most control consoles cannot withstand an interruption of the power that feeds them. The LM2500 will shut down if power is removed from the fuel valve solenoids. Therefore, these vital engineering functions must be maintained during a power interruption.

To provide power for vital pieces of equipment during short-term operation, gas turbine ships are designed with battery backup systems. This battery backup provides an alternate source of power upon failure of ship's service power. Because these systems need an immediate standby source of power, they must have a very rapid method of transferring the load to the backup. This is done by use of static (electronic) switching. The shift from failing 60-Hz power to the battery backup is very rapid. It is an uninterrupted shift. Therefore, the battery backup system is commonly known as an uninterruptible power supply (UPS).

All propulsion electronics rely on 115/120-volt ac as the input to their power supplies. The UPS battery systems for these consoles must provide power in that range. Batteries are normally a low-voltage dc power source. This means several batteries must be placed in series to obtain the proper voltage levels. We will refer to this group of batteries as a battery bank.

The UPS system is different on the FFG-7 class ships and the twin-shaft gas turbine ships. The UPS used on the FFG-7 class ship is the normal source of power for the propulsion electronics. It does not employ the batteries all the time, but the UPS equipment is the normal

source for console power. The DD-963, DDG-993, and CG-47 class ships use a slightly different concept for supplying uninterrupted power to consoles. On these ships the normal supply of power is from the ship's service 120-volt ac, 60-Hz bus. Power is also fed to the electronics from the 150-volt dc UPS battery bank. All switching for this system is done in the propulsion electronics. These classes also have battery backup for each SWBD and SSGTGs. The battery supply is an uninterruptible system but is NOT commonly referred to as UPS.

## **LEAD-ACID STORAGE BATTERIES**

Storage batteries provide the power source for the UPS system. Periodic inspection of the storage battery is essential in maintaining maximum efficiency and long life of the battery. Batteries used for UPS systems are subjected to moderately heavy use. They require frequent charging by the UPS battery charger.

As a GSE/GSM, you will be required to maintain these battery banks. All the batteries used in UPS systems are wet-cell types. Their maintenance requirements are special. For more information on battery construction and their principles of operation, refer to NEETS, module 1.

## **SUMMARY**

In this chapter we have discussed the major components of an ac electrical system. These included generators and motors, 60-Hz distribution system components, the UPS, and lead-acid storage batteries. You must remember that there are many different types of systems and components other than the ones we have discussed. Also, you should not undertake work on electrical equipment without reference to the proper technical manual.

For additional information on the material covered in this chapter, refer to *Naval Ships' Technical Manual*, chapter 300, "Electrical Plant General," chapter 310, "Electrical Power Generators and Conversion Equipment," and chapter 320, "Electrical Power Distribution System."





## CHAPTER 10

# ENGINEERING ELECTRICAL EQUIPMENT MAINTENANCE

This chapter was developed from the GSE3 OCCSTDs. However, by reading this chapter, a GSM will also be able to understand some of the maintenance requirements of electrical equipment.

Upon completing this chapter, you should be able to describe the basic techniques of wire wrapping, the maintenance requirements and troubleshooting techniques of electrical equipment, and the requirements of lead-acid storage batteries.

### WIRE WRAPPING

In chapter 3 you were shown some of the hand tools used for wire wrapping (fig. 3-13). In this section we will discuss the principles and techniques involved in wire wrapping.

The equipment that you would use the wire-wrap technique on has long square pins/posts at the rear of the female connectors used for logic card inserts. An example is the back-planes of various consoles. These pins are long enough to allow one to three wires to be wrapped on them in separate wraps. (A wrap is defined here as a series of turns of a single solid wire about a pin.) The female connectors are then interconnected from pin to pin by a small, solid insulated wire. This insulated wire may or may not be color coded. Machine-wrapped assemblies usually do not contain color-coded wiring. Hand-wired assemblies do contain color-coded wiring. (Color-coded wire is an advantage in hand-wired assemblies, since each wire becomes more distinctive and fewer errors are likely to result.)

### WIRE-WRAP PRINCIPLES

The principle behind wire wraps is a simple one. For proper conduction to occur between two metals, the oxide coating that has formed on both

surfaces must first be penetrated. As mentioned above, the pins used in the wire wraps are squared off. They have corner edges that will penetrate the oxide coating of the wire when it is properly wound on the pin. The edges will also lose their oxide coating when they penetrate the surface of the wire. The junction that is formed is strong, gastight (tight enough to seal out gases, in addition to liquids), and resistive to corrosion.

### WIRE-WRAP TECHNIQUES

The technique of wire wrapping is also fairly simple. A special solid conductor insulated wire is required. The use of solid conductor wire ensures that the coil will form tightly about the pin and remain that way without appreciable slippage. The wire is a composition of a silver alloy with a copper coating. Silver offers an advantage in that its oxide is almost as conductive as the metal itself. Teflon or Meline is usually the insulation used on the wire. Teflon offers an advantage of very high temperature stability and ease of cutting (for stripping by automatic machinery). It also has the undesirable trait of the insulation gradually receding away from any point of continued pressure—a process described as “cold flow.” Teflon-insulated wire in contact with a pin may eventually result in an intermittent short occurring at that point. Meline withstands continued exposure to pressure much better than Teflon. It is more resistive to cold flow, but does not have the very high temperature characteristics of Teflon. Meline has become more widely used because of the cold flow problem.

The first step in wire wrapping is for you to determine the correct gauge of wire required to perform the job. Strip off enough insulation to allow the correct number of turns to be wound around the pin. Then place the end of the wire in either a long shallow groove along the barrel of the wire-wrap tool, or insert it in the smaller

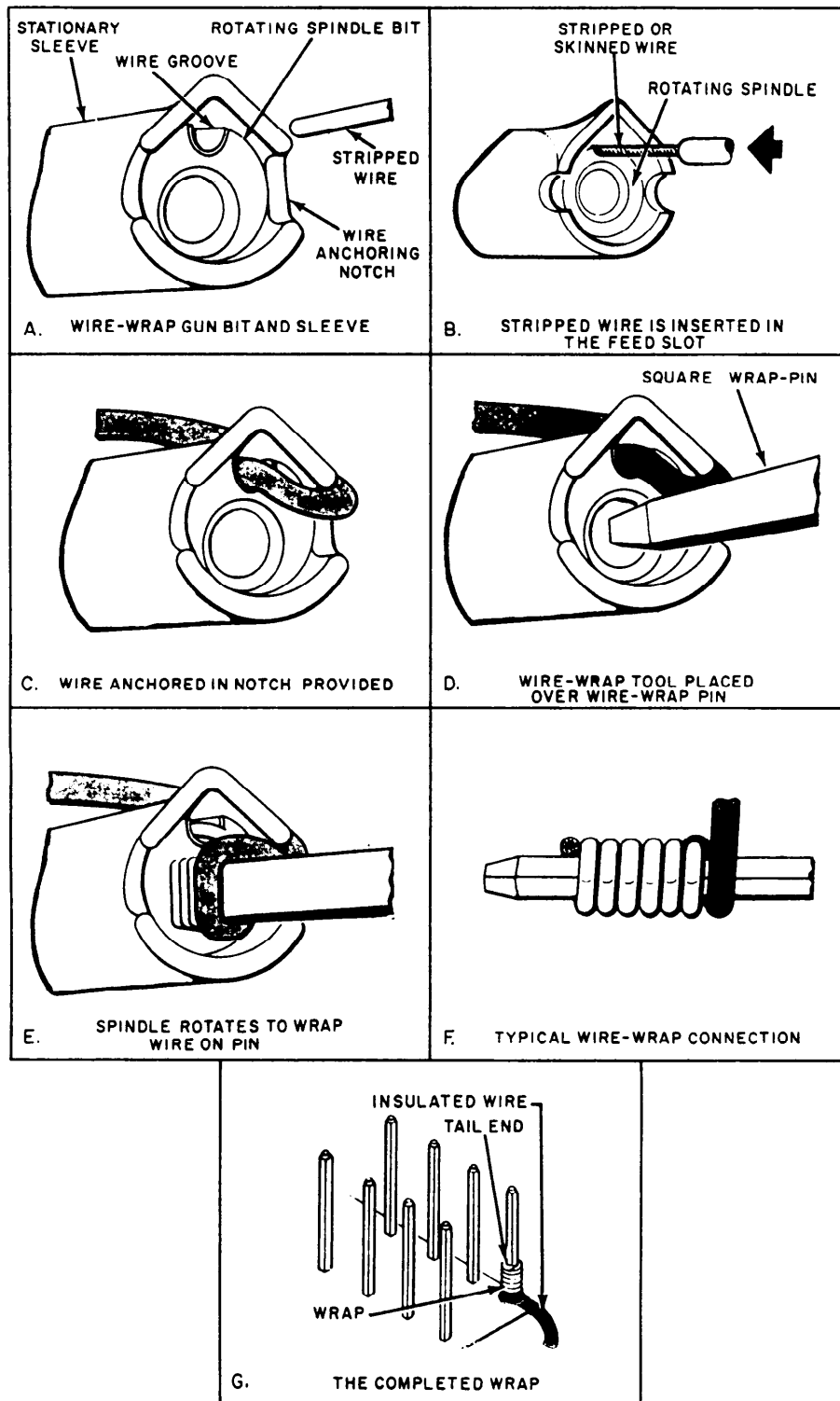

Figure 10-1.—Basic wire-wrap procedure.

hole at the end of the barrel (fig. 10-1, view A). The groove (or hole) for the wire is carefully sized to provide the exact amount of tension needed to form a secure wrap. Ensure the insulation bottoms into the wire funnel as shown in view B of figure 10-1. This will allow you to wrap the correct amount (one to one and a half turns) of insulated wire around the wrap pin. Anchor the wire by bending it into the notch in the sleeve (fig. 10-1, view C). The center hole at the end of the barrel is next slipped down over the pin (fig. 10-1, view D). When the barrel is rotated about the pin, the wire will twist around the pin (fig. 10-1, view E). As the wire twists around the pin, the stripped portion of the wire that is being held in the groove (or in the other base hole) will be drawn down to twist and coil around the pin. The barrel of the wire-wrap tool rotates as a result of finger, hand, or motor action. The action depends upon the tool's design. The coiling action of the wire on the pin lifts the tool enough to continue the wire coil up the pin, as shown in views F and G of figure 10-1. However, too much pressure on the tool will cause the coils to "bunch," or overlap. If you are replacing a wire, carefully run the wire to the next connection and perform the same procedure on the opposite end. Be sure you allow enough excess wire for the wraps needed on the pin.

Before actually doing a wire wrap on the item you are repairing, take time to practice this procedure. Find a spare connector or spare pin similar to those you are repairing. Using the same materials that are required for the actual job, practice a few times. Figure 10-2, view A, shows a good wire wrap. It has five to seven and a half snug turns of wire. Place the insulation about the bottom-most one or two turns with no spacing between adjacent turns, no bunching as one turn attempts to cover another, and no observable nicks in the wire. The number of turns is determined by the wire gauge. Larger diameter wires and pins require fewer turns, and smaller diameters mean more turns.

The following list describes a variety of INCORRECT methods of wire wrapping. Some of these are visually identifiable in figure 10-2, view B.

1. Insufficient tension on wire—results in loose connection (detected by open spaces between adjacent turns)

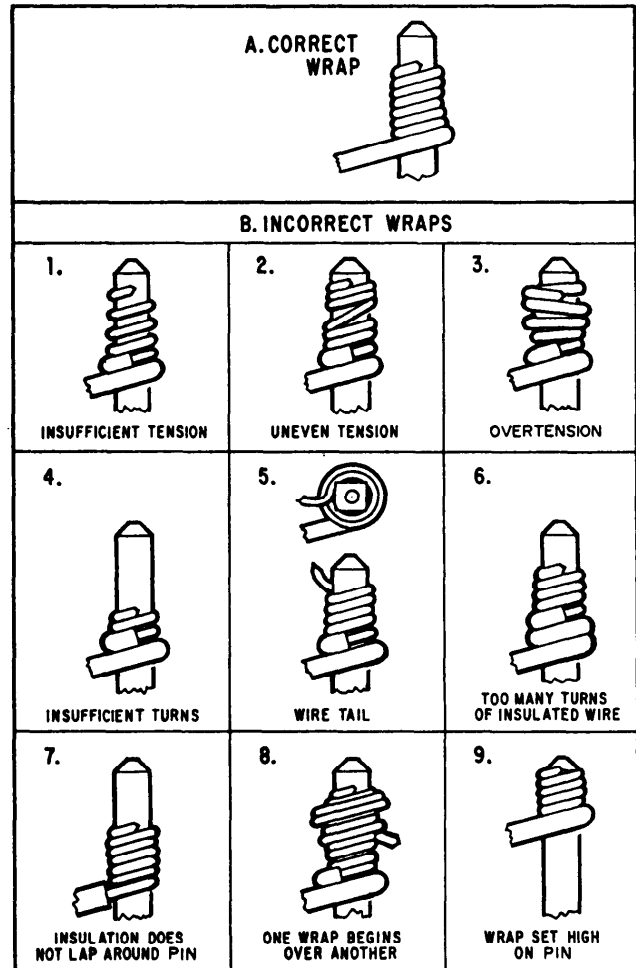

Figure 10-2.—Correct and incorrect wire wraps.

2. Overtension on wire—results in loose connection (detected by turn overlaps and insufficient surface contact with the pin)
3. Insufficient number of turns (less than five)—poor contact (insufficient wire was stripped first)
4. Insulation does not extend to pin—increased chances of shorts or wire breaks (too much wire was stripped)
5. Reuse of an uncoiled wrap—each reuse increases the likelihood of wire breaks
6. Attempts to wrap by hand—insufficient and uneven tension results in poor contact

Wire wraps are normally removed with a wire-wrap removal tool (fig. 10-3). This prevents stress and possible damage to the wire-wrap pin. However, if you have to remove the wire by hand, unwrap the wire without applying stress to the pin. You can best accomplish this by gently uncoiling the wire with a slight rotating movement over the point of the pin. Make sure that the manner in which the wire is removed does not cause movement of the pin itself (fig. 10-4). If a pin is bent, it will probably break when an effort is made to straighten it. If a pin breaks, first ensure that the broken length is not left in the wiring to cause possible shorts. Then take the necessary steps to install a new pin. Normally, inner wire wraps are placed near the bottom of the pin to ensure that

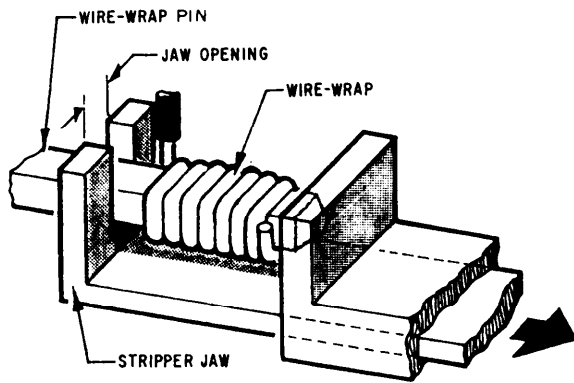

Figure 10-3.—Wire-wrap removal with wire-wrap removal tool.

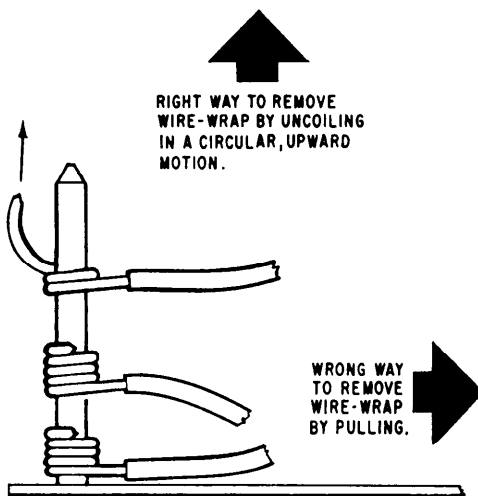

Figure 10-4.—Manual method of removing a wire wrap.

additional wraps can be added easily. If you have to remove a lower wire wrap, first remove each wrap above it. Do not remove a wire wrap by trying to pull it along its axis (see fig. 10-4). Remember, each wrap is easily identified because it is formed from the multiple turns of a single solid wire.

When removing a wire wrap from a pin, you must be careful not to disturb other wraps on the same or adjacent pins or to dislodge the pin. This would cause poor continuity or an open circuit.

### Advantages

Some of the advantages of wire wraps are as follows:

1. Simplified technique for repairs (wires are merely uncoiled to remove and replaced with the proper simple tools)
2. No solder spill (makes repairs possible without removing components)
3. No danger of components overheating as during soldering
4. More in-equipment repairs and faster repair times
5. No danger of burning personnel (as from a hot soldering iron)
6. Durable electrical contact (as good as have been achieved with good soldering technique, and superior to those connections made with poor soldering technique)

### Disadvantages

Some of the disadvantages of wire wraps are as follows:

1. Use of solid wire (increases the likelihood of wire breakage)
2. Problems with insulation
3. Unsuitable to subminiature assemblies
4. Lack of a wire color code in machine-wrapped assemblies
5. The necessity of clipping off the wrapped portion of the wire and stripping the insulation back to expose new wire in making the next wrap. (If the wire is too short to permit this, it must be replaced. The reason the same portion of wire is not reused in the new wrap is that this area will have been weakened structurally by nicks from its previous use and will be weakened further if reused.)

A number of useful tools, and techniques for using them, have been developed for doing wire wraps. We have discussed only some of them. For an excellent source on wire-wrapping techniques, refer to MILSTD (military standard) 1130B, notice 2, 20 July 1983, *Connections, Electrical, Solderless, Wrapped*.

Use caution in working with wire-wrap assemblies. These assemblies look like a bed of nails, and people have been injured by simply not taking precautions. A number of injuries occur to the face when the technician attempts to get a good look at the assembly from the side. This exposes the eyes to a needless hazard. Use sufficient lighting to make out details, small mirrors where possible, and wear safety goggles if a firsthand view from this position is necessary. When inspecting/repairing the back-planes or areas of possible damage, remember that ac or dc voltages may still be present. Ensure proper safety precautions are followed for working with energized equipment.

## MOTORS AND GENERATORS

At the shipboard level, maintenance on motors and generators is usually limited to cleaning, bearing repair, and brush maintenance. Major repairs, such as rewinding and balancing, are done at IMAs or shipyards.

### CLEANING MOTORS AND GENERATORS

One of your most important jobs is to keep all electrical machinery clean. Dust, salt, dirt, and foreign matter (such as carbon, copper, or mica) tend to block ventilation ducts. This increases resistance to the dissipation of heat and causes local or general overheating. If the particles form a conducting paste through the absorption of moisture or oil, the windings may become short circuited or grounded. Additionally, abrasive particles may puncture insulation; iron dust is very harmful since the dust is agitated by magnetic pulsations. Proper cleaning of motors and generators involves the use of wiping rags, suction, LP air, and solvents.

Wiping with a clean, lint-free, dry rag (such as cheesecloth) removes loose dust or foreign particles from accessible parts. When wiping, do not neglect the end windings, slip ring insulation, connecting leads, and terminals.

Suction is preferred to compressed air for removing abrasive dust and particles from inaccessible parts. This is because it lessens the possibility of damage to insulation. A vacuum cleaner is good for this purpose. If one is not available, a flexible tube attached to the suction side of a portable blower makes a usable vacuum cleaner. Always exhaust the blower to a suitable sump or overboard. When possible, remove grit, iron dust, and copper particles only by suction methods.

Clean, dry, compressed air is effective in removing dry, loose dust and foreign particles, particularly from inaccessible locations such as air vents in the armature. Use air pressure up to 30 psi to blow out motors or generators of 50 hp or 50 kW or less; use pressure up to 75 psi to blow out higher-rated machines. Where air lines carry higher pressure than is suitable, use a throttling valve to reduce the pressure. Always blow out any accumulation of water in the air line before directing the airstream on the part or machine to be cleaned.

### CAUTION

Be very careful when using compressed air, particularly if abrasive particles are present because they may be driven into the insulation and puncture it or be forced beneath insulating tapes. Use compressed air only after you have opened the equipment on both ends to allow the air and dust to escape. Using compressed air is of little benefit if the dust is not suitably removed from the equipment. The most suitable method of removing dirt-laden air is to place a suction hose on the opposite end of the equipment where compressed air is being used.

Whenever possible, avoid the use of solvents for cleaning electrical equipment. However, their use is necessary for removing grease and pasty substances consisting of oil and carbon or dirt. Alcohol will injure most types of insulating varnishes, and it should not be used for cleaning electrical equipment. Because of their high toxicity, solvents containing gasoline, benzene, and carbon tetrachloride must NEVER be used for cleaning purposes.

Motors, generators, and other electrical equipment that have been wet with salt water should be flushed out with fresh water and dried. Never

let the equipment dry before flushing with fresh water. For complete information on approved solvents and washing and drying procedures, refer to *NSTM*, chapter 300.

## BEARINGS

Bearings are designed to allow a rotating armature or rotor to turn freely within a motor or generator housing. Shaft bearings must be properly maintained to reduce the heat caused by friction.

The two common types of bearings found in motors and generators are antifriction bearings and friction bearings.

### Antifriction Bearings

There are two types of antifriction bearings—ball and roller. Basically, both types consist of two hardened steel rings, hardened steel rollers or balls, and separators. The annular, ring-shaped ball bearing is the type of roller bearing used most extensively in the construction of electric motors and generators used in the Navy. These bearings are further divided into three types dependent upon the load it is designed to bear— (1) radial, (2) axial thrust, and (3) angular contact. Examples of these three bearings are shown in figure 10-5.

The ball bearing on a rotating shaft of an electric motor or generator may be subjected to a radial, thrust, and/or angular force. While every ball bearing is not subjected to all three forces, any combination of one or more may be found depending on the equipment design. Radial loads are the result of forces applied to the bearing

perpendicular to the shaft. Thrust loads are the result of forces applied to the bearing parallel to the shaft. Angular loads are the result of a combination of radial and thrust loads. The load carried by the bearings in electric motors and generators is almost entirely due to the weight of the rotating element. For this reason, the method of mounting the unit is a major factor in the selection of the type of bearing installed when the unit is constructed. In a vertically mounted unit, the thrust bearing is used, while the radial bearing is normally used in most horizontal units.

**WEAR.**—Normally, it is not necessary to measure the air gap on machines with ball bearings, because the construction of the machines ensures proper bearing alignment. Additionally, ball bearing wear of sufficient magnitude as to be readily detected by air-gap measurements would be more than enough to cause unsatisfactory operation of the machine.

The easiest way of determining the extent of wear in these bearings is to periodically feel the bearing housing while the machine is running to detect any signs of overheating or excessive vibration and to listen to the bearing for the presence of unusual noise.

Rapid heating of a bearing may be an indication of danger. Bearing temperature that feels uncomfortable to the touch could be a sign of dangerous overheating, but not necessarily. The bearing may be operating properly if it has taken an hour or more to reach that temperature, but serious trouble can be expected if a high temperature is reached within the first 10 or 15 minutes of operation.

The test for excessive vibration relies a great extent on the experience of the person conducting the test. The person should be thoroughly familiar with the normal vibration of the machine to be able to detect, identify, and interpret correctly any unusual vibrations. Vibration, like heat and sound, is easily telegraphed. A thorough search is generally required to locate its source and to determine its cause.

Ball bearings are inherently more noisy in normal operation than sleeve bearings. If you are testing for the presence of abnormal bearing noise, keep this in mind. A common method for sound testing is to place one end of a screwdriver against the bearing housing and the other end against the ear. If a loud, irregular grinding, clicking, or scraping noise is heard, trouble is indicated. As before, the degree of reliance in the results of this

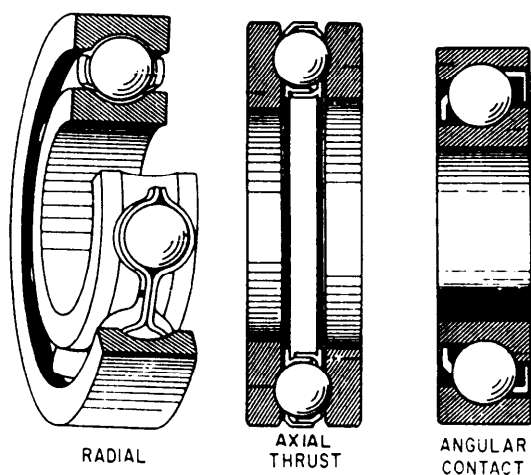

Figure 10-5.—Representative types of ball bearings.

test depends on the experience of the person conducting the test.

Vibration analysis equipment is also used to test conditions of motor bearings. Initial baseline surveys are taken. Then periodic checks are made by maintenance personnel. The periodic checks determine if the bearings are still in normal working condition or if they are failing. Consult your ship's PMS documentation for the method used for vibration analysis on your ship.

Checking the movement of a motor or generator shaft can also give an indication of the amount of bearing wear. Figure 10-6, view A, shows how to get a rough check of vertical movement. If the motor shaft has too much vertical movement, it has worn bearings. Figure 10-6, view B, shows how to get a rough check of generator end-play movement. You can correct excessive end-play, as described in the applicable technical manual, by adding bearing shims.

**BEARING INSTALLATION.**—There are two acceptable methods for installing bearings, the arbor press method and the heat method.

**Arbor Press Method.**—When available and adaptable, you can use an arbor press if you take proper precautions. Place a pair of flat steel blocks under the inner ring or both rings of the bearing. Never place blocks under the outer ring only. Then, line up the shaft vertically above the bearing. Place a soft pad between the shaft and press ram. After making sure the shaft is started straight in the bearing, press the shaft into the bearing. Press until the bearing is flush against the shaft or housing shoulder. When pressing a bearing onto a shaft, always apply pressure to the inner ring; when pressing a bearing into a housing, always apply pressure to the outer ring.

**Heat Method.**—You can heat a bearing in an oven or furnace to expand the inner ring for

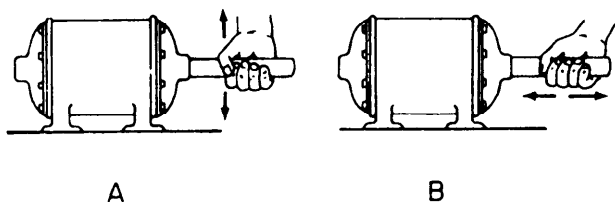

Figure 10-6.—Checking motor or generator shaft. A. Vertical movement. B. End-play movement.

assembly. This method ensures uniform heating around the bearing.

Heat the bearing in an IR oven or a temperature-controlled furnace at a temperature not to exceed  $203^{\circ} \pm 10^{\circ}\text{F}$ . Do not leave the bearing in the oven or furnace after the inner race has expanded the desired amount. Prolonged heating could deteriorate the prelubrication grease.

Additional methods of bearing installation are explained in *NSTM*, chapter 244.

## Friction Bearings

There are three types of friction bearings, **RIGHT LINE**, **JOURNAL**, and **THRUST**. In the **RIGHT LINE** type, the motion is parallel to the elements of a sliding surface. In the **JOURNAL** type, two machine parts rotate relative to each other. In the **THRUST** type, any force acting in the direction of the shaft axis is taken up. The SS generators are equipped with journal bearings, commonly called **SLEEVE** bearings. The bearings may be made of bronze, babbitt, or steel-backed babbitt. Preventive maintenance of sleeve bearings requires periodic inspections of bearing wear and lubrication.

**WEAR.**—You can obtain bearing wear on a sleeve bearing by measuring the air gap at each end of the machine. Use a machinist's tapered feeler gauge. Use a blade long enough to reach into the air gap without removing the end brackets of the machine. For ac machines, clean a spot on the rotor and at least three or more spots at equal intervals around the circumference on the stator. Take the air gap measurement between the cleaned spot on the rotor and a cleaned spot on the stator. Turn the rotor to bring the cleaned spot of the rotor in alignment with the cleaned spots on the stator. Compare these readings with the tolerance stated by the manufacturers' instruction manuals.

**TROUBLE ANALYSIS.**—The earliest sign of sleeve bearing malfunction normally is an increase in the operating temperature of the bearing. An RTD is usually inserted in a bearing for visual indication of the bearing temperature at a remote location. Personnel operating the equipment can use the inserted thermometer in the lube oil discharge line for local monitoring. Operating personnel take temperature readings hourly on running machinery. Therefore, after checking the temperature, they should make a follow-up check by feeling the bearing housing whenever possible.



Operating personnel must thoroughly familiarize themselves with the normal operating temperature of each bearing. They have to recognize any sudden or sharp changes in bearing temperature.

Any unusual noise in operating machinery may also indicate bearing malfunction. When a strange noise is heard in the vicinity of operating machinery, make a thorough inspection to determine its cause. Excessive vibration will occur in operating machinery with faulty bearings. Make inspections at frequent intervals to detect faulty bearings as soon as possible.

## **BRUSHES**

The brushes used in generators are one or more plates of carbon bearing against a collector ring (slip ring). They provide a passage for electrical current to an internal or external circuit. The brushes are held by brush holders mounted on studs or brackets attached to the brush-mounting ring, or yoke. The brush holder studs, or brackets, and brush-mounting ring comprise the brush rigging. The brush rigging is insulated from, but attached to, the frame or one end bell of the machine. Flexible leads (pigtailed) connect the brushes to the terminals of the external circuit. An adjustable spring is generally provided to maintain constant pressure of the brush on the slip ring. This is required to retain good contact between the brushes and slip rings without excessive wear of the brushes.

Brushes are manufactured in different grades to meet the requirements of the varied types of service. The resistance, ampere-carrying capacity, coefficient of friction, and hardness of the brush are set by the maximum allowable speed and load of the machine.

### **Correct Brush Type**

The correct grade of brush and correct brush adjustment are necessary to avoid brush performance trouble.

Use the grade of brush shown on the drawing or in the technical manual applicable to the machine. An exception to this is when Naval Sea Systems Command instructions issued after the date of the drawing or technical manual state otherwise. In such cases, follow the Naval Sea Systems Command instructions.

### **Brush Care**

You should ensure that all brush shunts are securely connected to the brushes and the brush

holders. Brushes should move freely in their holders. They should not be loose enough to vibrate in the holder. Before replacing a worn brush with a new one, clean all dirt and other foreign material from the brush holder.

Replace with new brushes, all brushes that

1. are worn or chipped so they will not move properly in their holders;
2. have damaged shunts, shunt connections, or hammer clips;
3. have riveted connections or hammer clips and are worn to within 1/8 inch of the metallic part;
4. have tamped connections, are without hammer clips, and are worn to one half or less of the original length of the brush; or
5. have spring-enclosed shunts and are worn to 40 percent or less of the original length of the brush (not including the brush head, which fits into one end of the spring).

Where adjustable brush springs are of the positive gradient (torsion, tension, or compression) type, adjust them as the brushes wear to keep the brush pressure near constant. Springs of the coiled-band, constant-pressure type and some springs of the positive gradient type are not adjustable. On these you have to change springs. You should adjust brush pressure following the MRC, the manufacturer's technical manual, or *NSTM*, chapter 300. To measure the pressure of brushes operating in box-type brush holders, insert one end of a strip of paper between the brush and slip ring. Use a small brush tension gauge (such as the 0- to 5-pound indicating scale) to exert a pull on the brush toward the brush holder axis as shown in figure 10-7. Note the reading of the gauge when the pull is just sufficient to release the strip of paper so it can be pulled out from between the brush and slip ring without offering resistance. This reading divided by the contact area may be considered to be the spring operating pressure.

## **DISASSEMBLY AND REASSEMBLY OF MOTORS AND GENERATORS**

When you have to disassemble and reassemble a large motor or generator, follow the procedures in the manufacturers' technical manuals. Never be hasty or careless in disassembling a generator or motor. Handle the delicate components with care to prevent or create the need for additional adjustment. Use the proper tools, and label the

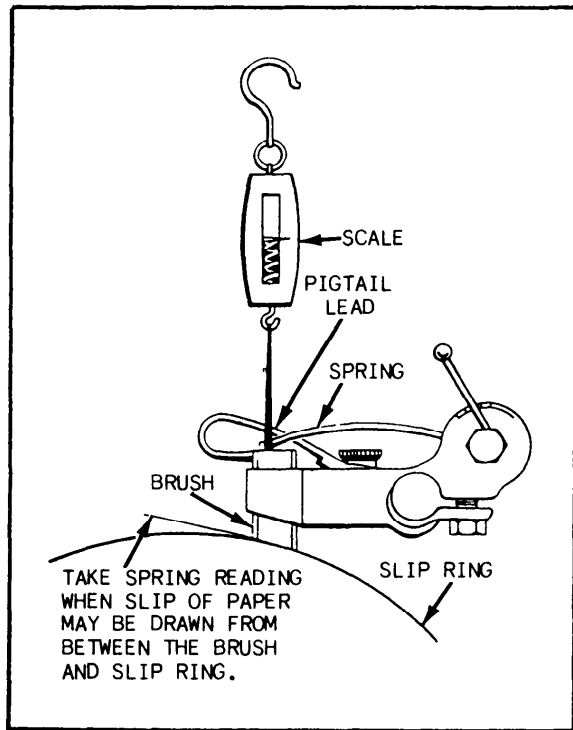

Figure 10-7.—Measuring brush tension.

parts as you dismantle them. Store them in an orderly arrangement in a safe place. Note the necessary information so you will have no trouble in reassembly.

Follow these simple steps when disassembling a motor or generator. Make sure you mark the frame and mating end bells (fig. 10-8); use a different mark for each end. When separating the end bells from the frame, use a mallet or block of wood with a hammer (fig. 10-9). Never pry mating surfaces apart with a metal object such as a screwdriver. Protect the windings, when necessary, by inserting thin strips of waxed paper between the rotor and the stator when the rotor is not supported.

When removing bearings, you can use an arbor press if you take proper precautions. Place a pair of flat steel blocks under the inner ring or both rings of the bearing. Never place blocks under the outer ring only. You may use a gear puller to remove a rotor bearing. However, be careful.

Clean the end bells with a brush and an approved solvent. Check them for cracks, burrs, nicks, excessive paint, and dirt.

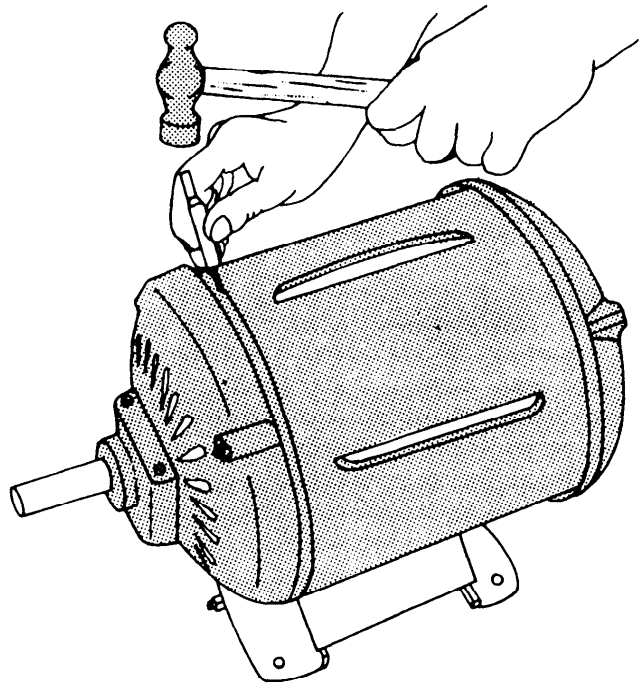

Figure 10-8.—Marking a motor frame and end bell.

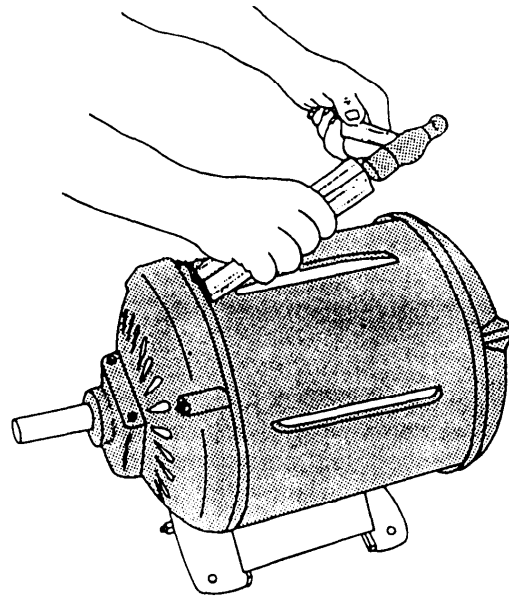

Figure 10-9.—Parting end bells with a hammer and wood block.

## CIRCUIT BREAKER MAINTENANCE

The circuit breakers (CBs) require careful inspection and cleaning following the MRC, the

manufacturers' technical manuals, or *NSTM*, chapter 300.

Before working on a CB, de-energize all control circuits to which it is connected; the procedures differ somewhat with the type of mounting that is used. On drawout CBs, ensure they are switched to the open position and removed. When working on fixed-mounted CBs, open the disconnecting switches ahead of the breakers. If disconnecting switches are not provided for isolation, de-energize the supply bus to the CB. Circuit breakers have different time delay characteristics, such as short time, long time, or instantaneous trip. The adjustments for selective tripping of most CBs are made and sealed at the factory. You should not normally make changes to their trip settings, as these changes may completely disrupt their intended functions of protection. If improper tripping action occurs as the result of a malfunction within the breaker, the simplest means to correct the problem is to replace the entire breaker.

After a CB cover has been removed, you should check the interior components, such as contacts, overcurrent tripping devices, connections, and moving mechanical parts.

Contacts are the metal parts especially selected to resist deterioration and wear as a result of arcing. The arcing occurs in a CB while its contacts are opening and carrying current at the same time. When firmly closed, the contacts must not arc.

Contact materials have been subjected to constant research. The result is various products, ranging from pure carbon or copper to pure silver. Each is used alone or as alloys with other substances. Modern CBs have contacts made of a silver alloy coated with silver, or silver mixed with tungsten. The silver alloy is extremely hard and resists being filed. Such contacts made of silver alloy conduct current when discolored (blackened during arcing) with silver oxide. The blackened condition, therefore, requires no filing, polishing, or removal. However, severe pitting or burning of a silver contact may require some filing with a fine file or with fine sandpaper, No. 00. Never use emery paper or emery cloth to remove raised places on surfaces that prevent full surface closure of the contact surfaces. If necessary, wipe the contacts with a CLEAN cloth moistened with INHIBITED methyl chloroform solvent. To remove all DEADLY and TOXIC fumes of the solvent, provide VERY LIBERAL ventilation with exhaust fans or with portable blowers.

The function of arcing contacts is not necessarily impaired by surface roughness. Remove very rough spots with a fine file. Replace arcing contacts when they have been burned severely and cannot be properly adjusted. Make a contact impression and check the spring pressure following the manufacturer's instructions. If information on the correct contact pressure is not available, check the contact pressure with that of similar contacts that are functioning properly. When the force is less than the designed value, the contacts either require replacing because they are worn down, or the contact springs should be replaced. Always replace contacts in sets, not singly, and replace contact screws at the same time.

Clean all surfaces of the CB mechanism, particularly the insulation surfaces, with a dry cloth or air hose. Before directing the air on the breaker, be certain (1) the water is blown out of the hose, (2) the air is dry, and (3) the pressure is not over 30 psi. Check the pins, bearings, latches, and all contact and mechanism springs for excessive wear or corrosion and evidence of overheating. Replace parts if necessary.

Slowly open and close CBs manually a few times. Be certain trip shafts, toggle linkages, latches, and all other mechanical parts operate freely and without binding. Be certain the arcing contacts make-before and break-after the main contacts. If you note poor alignment, sluggishness, or other abnormal conditions, adjust following the manufacturer's instructions for the particular CB.

Keep the sealing surfaces of CB contactor and relay magnets clean and free from rust. Rust on the sealing surface decreases the contact force. This may result in overheating of the contact tips. Loud humming or chattering will often warn of this condition. A light machine oil wiped sparingly on the sealing surfaces of the contactor magnet will aid in preventing rust.

Always use oil sparingly on CBs, contactors, motor controllers, relays, and other control equipment. Do not use it at all unless it is called for in the manufacturer's instructions or unless oil holes are provided. If working surfaces or bearings show signs of rust, disassemble the device and carefully clean the rusted surfaces. Wipe light oil on sparingly to prevent further rusting. Oil has a tendency to accumulate dust and grit. This will cause improper operation of the device, mainly if the device is delicately balanced.

Clean arc chutes with a stiff brush and a cloth. Replace broken or deeply burned arc chutes. Be

certain arc chutes are securely fastened. Be sure there is enough clearance to prevent interference when the switch or contact is opened or closed.

Replace shunts and flexible connectors, which are flexed by the motion of moving parts, when worn, broken, or frayed.

Regularly test the CBs by testing them on how they are intended to function. For manually operated CBs, simply open and close the breaker to check the mechanical operation. To check the mechanical operation and the control wiring, test electrically operated CBs by the operating switch or control. Exercise care not to disrupt any electric power supply that is vital to the operation of the ship. Also, be careful not to endanger personnel by inadvertently starting motors and energizing equipment under repair.

Before returning a CB to service, inspect all mechanical and electrical connections. These include mounting bolts and screws, drawout disconnect devices, and control wiring. Tighten where necessary. Give the breaker a final cleaning with a cloth or compressed air. Operate manually to be certain all moving parts function freely. Check the insulation resistance with a Megger before reinstalling the CB in the SWBD.

## CONTROLLER TROUBLESHOOTING

Although the Navy maintains a policy of preventive maintenance, sometimes trouble is unavoidable. In general, when a controller fails to operate or signs of trouble (heat, smoke, or smell of burning) occur, you can find the cause of the trouble by a simple examination using the sense of feel, sight, or smell. However, at other times, finding the trouble involves more detailed actions.

Troubles tend to gather around mechanical moving parts. Problems also occur where electrical systems are interrupted by the making and breaking of contacts. Center your attention in these areas.

When a motor-controller system has failed and pressing the START button will not start the system, press the overload relay reset push buttons. Then attempt to start the motor; if the motor operation is restored, no further checks are required. However, if you hear the controller contacts close but the motor fails to start, check the motor circuit continuity. If the main contacts don't close, check the control circuit for continuity. In the following paragraphs, an

example of troubleshooting a motor-controller electrical system is given in a sequence of steps that may be used in locating a fault (fig. 10-10). We will analyze the power circuit and then the control circuit.

## POWER CIRCUIT ANALYSIS

When no visual signs of circuit failure can be located and an electrical failure is indicated in the power circuit, first check the line voltage and fuses (or CB), as shown in figure 10-10. Place the voltmeter probes on the hot side of the line fuses as shown at position A. A line voltage reading tells you that your voltmeter (VM) is operational. It tells you that you have voltage to the source side of the line fuses. You may also check between the other lines. To check the fuse in line 1 (L1), place the voltmeter across the line fuse as

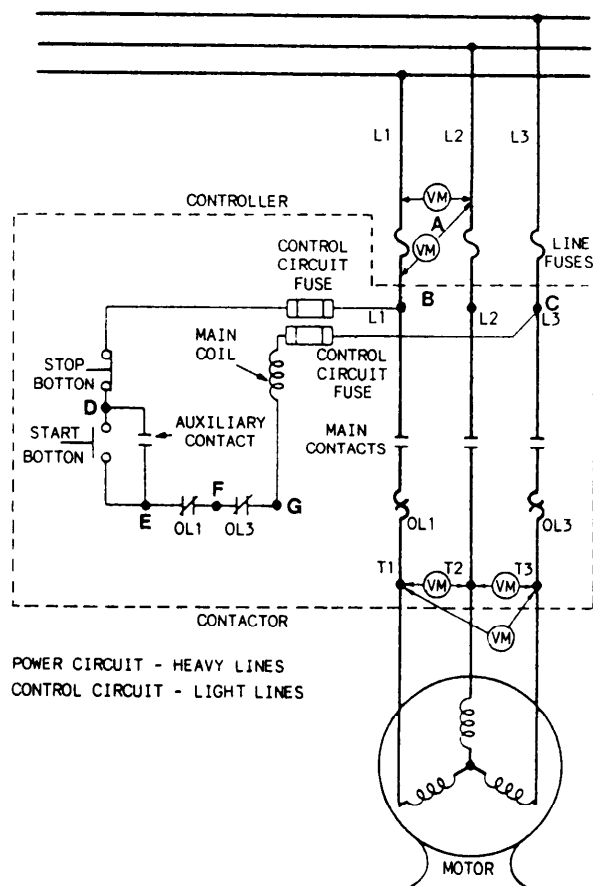

Figure 10-10.—Troubleshooting a 3-phase magnetic controller.

shown at position B between L1-L2. A voltage reading shows a good fuse in L1. Likewise, check the other two fuses between L1-L3 and L2-L3. A no-voltage reading would show a faulty fuse.

If the line fuses check good and the main contacts are closed, then check the voltage between terminals T1-T2, T2-T3, and T1-T3. The controller is faulty if there are no voltmeter readings on all three of the terminal pairs. You would then proceed to check the main contacts, overloads, and lead connections within the controller. However, if there is voltage at all three terminals, the trouble is either in the motor or the lines leading to the motor.

## CONTROL CIRCUIT ANALYSIS

Suppose the overload reset buttons have been reset and the START switch closed. If the main contacts do not close, check the control circuit. A testing procedure follows.

1. Check for voltage in the controller at L1, L2, and L3.
2. Place the voltmeter probes at points C and D (fig. 10-10). You should have a voltage reading when the STOP switch is closed. You should have a no-voltage reading when the STOP switch is open. The conditions would indicate a good STOP switch and control circuit fuse.
3. Next, check the voltage between points C and E. The START switch is good if you get a no-voltage reading when the START switch is open. The START switch is also good if you get a voltage reading when the START switch is closed.
4. Place the voltmeter probes at points C and F. A voltage reading with the START switch closed would indicate a good OL1. It would also indicate one of the following components is open: OL3, the main coil, the control fuse, or the connection to L3.
5. Place the voltmeter probes at points C and G. Close the START switch. A no-voltage reading locates the trouble in the control circuit to OL3.

A faulty auxiliary contact is indicated under the following conditions: (1) The system operates only as long as the START switch is held in the ON position; and (2) when the switch is released, the system will shut down.

When starting a 3-phase motor, if the motor fails to start and gives a loud hum, you should stop the motor by pushing the STOP switch. These symptoms usually mean that one of the phases to the motor is not energized. You can assume that the control circuit is good. This is because the main coil has operated and the auxiliary contacts are holding the main contactor closed. Look for trouble in the power circuit (the main contacts, overload relays, cable, and motor).

## LEAD-ACID STORAGE BATTERIES

Storage batteries provide the power source for the UPS battery system. Periodic inspection of the storage battery is essential in maintaining maximum efficiency and long life of the battery. Batteries used for UPS systems are subjected to moderately heavy use. They require frequent charging by the UPS battery charger or rectifier.

### SPECIFIC GRAVITY

The ratio of the weight of a certain volume of liquid to the weight of the same volume of water is called the specific gravity of the liquid. The specific gravity of pure water is 1.000. Sulfuric acid has a specific gravity of 1.830. A mixture of sulfuric acid and water is called electrolyte. The specific gravity of electrolyte will vary from 1.000 to 1.830.

As a storage battery discharges, the sulfuric acid is depleted. The electrolyte is gradually converted into water. This action is a guide in determining the state of discharge of the lead-acid cell. The maximum specific gravity of electrolyte placed in a lead-acid battery should be 1.350 or less. Generally, the specific gravity of the electrolyte in standard storage batteries is adjusted between 1.210 and 1.220.

### Measuring Specific Gravity

The specific gravity of the electrolyte is measured using a hydrometer, which was discussed in chapter 3. Figure 3-40 shows a hydrometer. The hydrometer used with portable storage batteries has a float with a scale from 1.100 to 1.300. When taking a reading, ensure that the electrolyte in a cell is at the normal level. If the level is below normal, you cannot draw enough fluid into the tube to cause the float to rise. If the level is above normal, there is too much water. Then the electrolyte is weakened, and the

reading is too low. A hydrometer reading is inaccurate if you take it immediately after water is added. This is because the water tends to remain at the top of the cell. When water is added, charge the battery for at least an hour. This will mix the electrolyte before the hydrometer reading is taken.

### CAUTION

After use, flush hydrometers with fresh water. This prevents inaccurate readings. Do NOT use storage battery hydrometers for any other purpose.

### Correcting Specific Gravity

Temperature affects the specific gravity of electrolyte. When electrolyte is heated, it expands and becomes less dense. Its specific gravity reading is lowered. On the other hand, when electrolyte is cooled, it contracts and becomes denser when cooled. Its specific gravity reading is raised. In both cases, the electrolyte may be from the same fully charged storage cell.

When measuring the specific gravity, you must also measure the temperature of the electrolyte. Most standard storage batteries use 80°F as the normal temperature to which specific gravity readings are corrected. Figure 10-11 shows a temperature conversion chart for an 80°F hydrometer. You can also correct the specific gravity reading of a storage battery by adding 1 point for each 3°F above 80°F, or by subtracting 1 point for each 3°F below 80°F.

### Adjusting Specific Gravity

Sometimes the specific gravity of a cell is more than it should be. You can reduce it to within limits by removing some of the electrolyte and adding distilled water. As stated earlier, charge the battery for 1 hour to mix the solution. Then take hydrometer readings. Continue the adjustment until you get the desired true readings.

**NOTE:** Only authorized personnel should add acid to a battery. Acid with a specific gravity above 1.350 is NEVER added to a battery.

### MIXING ELECTROLYTE

The electrolyte of a fully charged battery usually has about 38 percent sulfuric acid by

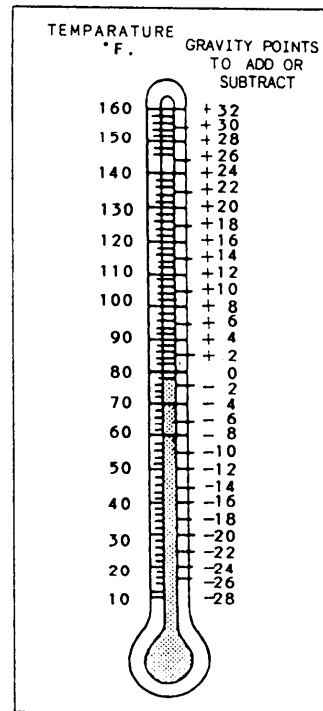

Figure 10-11.—Temperature conversion chart.

weight, or about 27 percent by volume. Distilled water and sulfuric acid are used to prepare the electrolyte. New batteries may be delivered with containers of concentrated sulfuric acid of 1.830 specific gravity or electrolyte of 1.400 specific gravity. You must dilute both of these with distilled water to make electrolyte of the proper specific gravity. Use a container made of glass, earthenware, rubber, or lead for diluting the acid.

### WARNING

When mixing electrolyte, ALWAYS POUR ACID INTO WATER—NEVER pour water into acid. Pour the acid slowly and cautiously to prevent excessive heating and splashing. Stir the solution continuously with a nonmetallic rod to mix the heavier acid with the lighter water. This will keep the acid from sinking to the bottom.- When concentrated acid is diluted, the solution becomes very hot.

### TREATMENT OF SPILLED ACID

If acid or electrolyte from a lead-acid battery comes into contact with the skin, wash the affected area with a large amount of fresh water.

A small amount of water might do more harm than good in spreading the acid burn. Afterwards, apply a salve such as petrolatum, boric acid, or zinc ointment. If none of these salves are available, clean lubricating oil will suffice. You can neutralize acid spilled on clothing with diluted ammonia or a solution of baking soda and water.

## CAPACITY

The capacity of a battery is measured in ampere-hours (amp-hr). The amp-hr capacity is equal to the product of the current in amperes and the time in hours during which the battery is supplying this current. The amp-hr capacity varies inversely with the discharge current. The size of a cell is determined generally by its amp-hr capacity. The capacity of a cell depends on many factors. The most important of these are as follows:

1. The area of the plates in contact with the electrolyte
2. The quantity and specific gravity of the electrolyte
3. The type of separators
4. The general condition of the battery (degree of sulfating, plates buckled, separators warped, sediment in bottom of cells, and so forth)
5. The final limiting voltage

## RATING

Storage batteries are rated according to their rate of discharge and amp-hr capacity. Most batteries are rated according to a 10-hour rate of discharge. That is, if a fully charged battery is completely discharged during a 10-hour period, it is discharged at the 10-hour rate. Thus, if a battery can deliver 20 amperes for 10 hours, the battery has a rating of  $20 \times 10$ , or 200 amp-hr. The 10-hour rating is equal to the average current that a battery can supply without interruption for 10 hours.

All standard batteries deliver 100 percent of their available capacity if they are discharged in 10 hours or more. But they will deliver less than their available capacity if they are discharged at a faster rate. The faster they discharge, the less amp-hr capacity they have.

## READINGS WHEN CHARGED AND DISCHARGED

At the conclusion of a 10-hour discharge test on a battery, the closed-circuit voltmeter reading will be about 1.75 volts per cell. The specific gravity of the electrolyte will be about 1.060. At the completion of a charge, the closed-circuit voltmeter reading at the finishing rate will be about 2.4 to 2.6 volts per cell. The specific gravity of the electrolyte corrected to 80°F will then be between 1.210 and 1.220.

## TYPES OF CHARGES

The following types of charges may be given to a storage battery, depending on the condition of the battery:

- Initial charge
- Normal charge
- Equalizing charge
- Floating charge
- Emergency charge

### Initial Charge

Initial charge is a long, low-rate, forming charge that is given to place a new battery in service. When a battery is shipped dry, the battery may be in the uncharged or dry-charged condition. After the electrolyte has been added, the uncharged battery must be given an initial charge. The addition of electrolyte to the dry-charged battery is sufficient for an initial charge. To charge the battery, follow the manufacturer's instructions. These are shipped with each battery. If the manufacturer's instructions are not available, refer to the instructions in current directives.

### Normal Charge

A normal charge is a routine charge. You should give it following the nameplate data during the ordinary cycle of operation. It restores the battery to its charged condition. Observe the following steps:

1. Determine the starting and finishing rate from the nameplate data.

2. Add water, as necessary, to each cell.
3. Connect the battery to the charging panel. Make sure the connections are clean and tight.
4. Turn on the charging circuit. Set the current through the battery at the value given as the starting rate.
5. Check the temperature and specific gravity of pilot cells hourly.
6. When the battery begins to gas freely, reduce the charging current to the finishing rate.

A normal charge is complete when the specific gravity corrected for temperature has reached a value within 5 points (0.005) of the specific gravity obtained on the previous equalizing charge.

### Equalizing Charge

An equalizing charge is an extended normal charge given only at the finishing rate. You should periodically conduct an equalizing charge to ensure all the sulfate is driven from the plates and all the cells are restored to a uniform maximum specific gravity. Continue the equalizing charge until the hydrometer readings show no increase in corrected specific gravity for any cell over a period of 4 hours. You should take the readings every 30 minutes.

### Floating Charge

You may maintain a battery at full charge by connecting it across a charging source that has a voltage maintained within the limits of from 2.13 to 2.17 volts per cell of the battery. In a floating charge, you determine the charging rate by the battery voltage rather than by a definite current value. Maintain the voltage between 2.13 and 2.17 volts per cell with an average as close to 2.15 volts as possible.

### Emergency Charge

Use an emergency charge when a battery must be recharged in the shortest possible time. Start the charge at a much higher rate than is normally used for charging. Use it only in an emergency. This type of charge may be harmful to the battery.

### CHARGING RATE

Normally, the charging rate of Navy storage batteries is given on the battery nameplate. If the

available charging equipment does not have the desired charging rates, use the nearest available rates. However, do not let the rate become so high that violent gassing occurs. NEVER ALLOW THE TEMPERATURE OF THE ELECTROLYTE IN ANY CELL TO RISE ABOVE 125°F (52°C).

### CHARGING TIME

Continue the charge until the battery is fully charged. Take frequent readings of specific gravity during the charge. Correct these readings to 80°F. Then, compare them with the reading taken before the battery was placed on charge. If you know the rise in specific gravity in points per amp-hr, the approximate time in hours required to complete the charge is as follows:

$$\frac{\text{Rise in specific gravity in points to complete charge}}{\text{Rise in specific gravity in points per amp-hr}} \times \frac{\text{Charging rate per amp}}{\text{per amp}}$$

### TEST DISCHARGE

The test discharge is the best method of determining the capacity of a battery. Most battery switchboards are provided with equipment for giving test discharges. If proper equipment is not available, a tender, a repair ship, or a shore station may perform the test discharge. A battery test discharge is required when one of the following conditions exists:

1. A functional test reveals a low output.
2. One or more cells are found to have less than normal voltage after an equalizing charge.
3. A battery cannot be brought to within 10 points of normal charge of its specific gravity.
4. A battery has been in service 4 years.

An equalizing charge must always precede a test discharge. After the equalizing charge, the battery is discharged at its 10-hour rate. This is done until the total battery voltage drops to a value equal to 1.75 times the number of cells in series or the voltage of any individual cell drops to 1.65 volts. Keep the rate of discharge constant throughout the test discharge. Because standard batteries are rated at the 10-hour capacity, the discharge rate for a 100 amp-hr battery is 100/10,



or 10 amperes. If the temperature of the electrolyte at the beginning of the charge is not exactly 80°F, correct the time duration of the discharge for the actual temperature of the battery.

A battery of 100 percent capacity discharges at its 10-hour rate for 10 hours before reaching its low-voltage limit. If the battery or one of its cells reaches the low-voltage limit before the 10-hour period has elapsed, discontinue the discharge immediately and determine the percentage of capacity using the following equation:

$$c = \frac{H_a}{H_t} \times 100$$

Where

C = percentage of amp-hr capacity available

H<sub>a</sub> = total hours of discharge

H<sub>t</sub> = total hours for 100 percent capacity

For example, a 100 amp-hr, 6-volt battery delivers an average current of 10 amperes for 10 hours. At the end of this period, the battery voltage is 5.25 volts. On a later test the same battery delivers an average current of 10 amperes for only 7 hours. The discharge was stopped at the end of this time because the voltage of the middle cell was found to be only 1.65 volts. The percentage of capacity of the battery is now  $7/10 \times 100$ , or 70 percent. Thus, the amp-hr capacity of this battery is reduced to  $0.7 \times 100 = 70$  amp-hr.

Record the date for each test discharge on the storage battery record sheet.

## STATE OF CHARGE

After a battery is discharged completely from full charge at the 10-hour rate, the specific gravity has dropped about 150 points to about 1.060. You can determine the number of points the specific gravity drops per amp-hr for each type of battery. For each amp-hr taken out of a battery, a definite amount of acid is removed from the electrolyte and combined with plates.

For example, if a battery is discharged from full charge to the low-voltage limit at the 10-hour rate, and if 100 amp-hr are obtained with a specific gravity drop of 150 points, there is a drop of  $150/100$ , or 1.5 points per amp-hr delivered. If you know the reduction in specific gravity per amp-hr, you can predict the drop in specific

gravity for this battery, for any number of amp-hr delivered to a load. For example, if 70 amp-hr are delivered by the battery at the 10-hour rate or any other rate or collection of rates, the drop in specific gravity is  $70 \times 1.5$ , or 105 points.

Conversely, if the drop in specific gravity per amp-hr and the total drop in specific gravity are known, you can determine the amp-hr delivered by a battery. For example, if the specific gravity of the previously considered battery is 1.210 when the battery is fully charged and 1.150 when it is partly discharged, the drop in specific gravity is 1.210 minus 1.150, or 60 points, and the number of amp-hr taken out of the battery is  $60/1.5$ , or 40 amp-hr. Thus, the number of amp-hr expended in any battery discharge can be determined from the following items:

1. The specific gravity when the battery is fully charged
2. The specific gravity after the battery has been discharged
3. The reduction in specific gravity per amp-hr

Voltage alone is not a reliable indication of the state of charge of a battery, except when the voltage is near the low-voltage limit on discharge. During discharge, the voltage falls. The higher the rate of discharge, the lower will be the terminal voltage. Open-circuit voltage is of little value because the variation between full charge and complete discharge is so small—only about 0.1 volt per cell. However, abnormally low voltage does indicate injurious sulfation or some other serious deterioration of the plates.

## GASSING

When a battery is being charged, a portion of the energy is dissipated in the electrolysis of the water in the electrolyte. Thus, hydrogen is released at the negative plates and oxygen at the positive plates. These gases bubble up through the electrolyte and collect in the air space at the top of the cell. If violent gassing occurs when the battery is first placed on charge, the charging rate is too high. If the rate is not too high, steady gassing, which develops as the charging proceeds, indicates that the battery is nearing a fully charged condition.

### **CAUTION**

A mixture of hydrogen and air can be dangerously explosive. **DO NOT** permit smoking, electric sparks, or open flames near charging batteries.

### **SUMMARY**

The information provided in this chapter should help you understand some of the basic

maintenance requirements of electrical equipment. Always use the PMS procedures when doing preventive maintenance, or use the applicable technical manual when troubleshooting. Strictly follow safety precautions found on MRCs and in technical manuals. When working around electrical equipment, remember that safety is the most important aspect of the job. Use the tag-out procedures, test your meters, use the two-man rule, and do not bypass any safety devices.



# APPENDIX I

## GLOSSARY

**ALARM ACKNOWLEDGE**—A push button that must be depressed to silence an alarm horn.

**ALLOWANCE PARTS LIST (APL)**—Repair parts required for units having the equipment/component listed.

**ALLOY**—Any composition metal produced by the mixing of two or more metals or elements.

**ALLOYING**—The procedure of adding elements other than those usually comprising a metal or alloy to change its characteristics and properties.

**ALLOYING ELEMENTS**—The elements added to nonferrous and ferrous metals and alloys to change their characteristics and properties.

**ALTERNATING CURRENT (ac)**—An electrical current that constantly changes amplitude and changes polarity at regular intervals.

**AMBIENT**—Surrounding on all sides, encompassing.

**AMBIENT PRESSURE/TEMPERATURE**—The surrounding pressure/temperature, such as the air pressure/temperature that surrounds a conductor in a compartment or a piece of equipment.

**AMMETER**—An instrument for measuring the amount of electron flow (in amperes).

**AMPERE (amp)**—A unit of electrical current or rate of flow of electrons. One volt across 1 ohm of resistance causes a current flow of 1 ampere. (Named after A. M. Ampere, a famous French physicist.)

**AMPLITUDE**—The size of a signal as measured from a reference line to a maximum value above or below the line. Generally used to describe voltage, current, or power.

**ANALOG DATA**—Data represented in continuous form, as contrasted with digital data having discrete values.

**ANALOG SIGNAL**—A measurable quantity that is continuously variable throughout a given range and that is representative of a physical quantity.

**ANALOG TO DIGITAL (A/D) CONVERSION**—A conversion that takes an analog input in the form of electrical voltage or current and produces a digital output.

**ANNULAR**—In the form of or forming a ring.

**ANNUNCIATOR**—A device that gives an audible and a visual indication of an alarm condition.

**ANTISEIZE COMPOUND**—A silicon-based, high-temperature lubricant applied to threaded components to aid in their removal after they have been subjected to rapid heating and cooling.

**ASBESTOS**—A noncombustible, nonconductive, fiber-like mineral used as an insulating material.

**ASBESTOSIS**—Fibrosis of the lungs caused by inhalation of asbestos.

**ATMOSPHERE**—A unit of measure equal to 14.696 psi or 29.92 inches of mercury (1 atmosphere = 14.696 psi).

**ATMOSPHERIC PRESSURE**—The pressure of air at sea level, approximately 14.7 psi.

**AUTOMATIC BUS TRANSFER (ABT)**—Normal and alternate power sources are provided to vital loads. These power sources are supplied from separate switchboards through separated cable runs. Upon loss of the normal power supply, the ABT automatically disconnects this source and switches the load to the alternate source.

**AUTOMATIC PARALLELING DEVICE (APD)**—The APD automatically parallels any two generators when initiated by the EPCC.

**AUXILIARY CONTROL CONSOLE (ACC)**—The console in CCS used to monitor the FFG-7 class auxiliary systems.

**BABBITT**—A white alloy of tin, lead, copper, and antimony that is used for lining bearings.

**BACK PRESSURE**—A pressure exerted contrary to the pressure producing the main flow on the discharge/exhaust side of an engine or pump.

**BAFFLE**—A plate, wall, or screen used to deflect, check, or otherwise regulate the flow of a gas, liquid, sound waves, and so forth.

**BATTERY**—A device for converting chemical energy into electrical energy.

**BATTERY CAPACITY**—The amount of energy available from a battery. Battery capacity is expressed in ampere-hours.

**BELL LOG**—A printed record of changes in the ship's operative conditions, such as speed or point of control.

**BLEED AIR**—Air bled off the compressor stages of the GTEs. See BLEED AIR SYSTEM.

**BLEED AIR SYSTEM (BAS)**—Takes air extracted from the compressor stage of a GTE and uses it for anti-icing, prairie air, masker air, and LP gas turbine starting for off-line GTEs.

**BLOCK DIAGRAM**—A diagram in which the major components of an equipment or a system are represented by squares, rectangles, or other geometric figures. The normal order of progression of signal flow, current flow, or component relationship is represented by lines.

**BLOW-IN DOORS**—Doors located on the high hat assembly designed to open by solenoid-operated latch mechanisms if the inlet airflow becomes too restricted for normal engine operation.

**BOILER RECORD SHEET**—A NAVSEA form maintained for each boiler, which serves as a monthly summary of operation.

**BORESCOPE**—A small periscope (instrument) used to visually inspect internal engine components.

**BOYLE'S LAW**—If the temperature of a gas is kept constant, then the volume of the gas will be inversely proportional to the pressure.

**BRITISH THERMAL UNIT (BTU)**—The amount of heat that will raise the temperature of 1 pound of water 1° Fahrenheit (from 62°F to 63°F).

**BUS**—An uninsulated power conductor (a bar or wire) usually found in a switchboard.

**BUS TIE BREAKER (BTB)**—A device used to connect one main switchboard to another main switchboard.

**CALIBRATION**—(1) The operation of making an adjustment or marking a scale so that the readings of an instrument conform to an accepted standard. (2) The checking of readings by comparison with an accepted standard.

**CALORIE**—The amount of heat required at a pressure of 1 atmosphere to raise the temperature of 1 gram of water 1° Centigrade.

**CAPILLARY TUBE**—A slender, thin-walled, small-bored tube used with remote-reading indicators.

**CASUALTY**—An event or series of events in progress during which equipment damage and/or personnel injury has already occurred. The nature and speed of these events are such that proper and correct procedural steps will only serve to limit equipment damage and/or personnel injury.

**CENTIGRADE (CELSIUS) SCALE**—A thermometric scale on which the interval between the freezing point (0°C) and the boiling point (100°C) of water is divided into 100 equal parts or degrees, so that 0°C = 32°F and 100°C = 212°F.

**CENTRAL CONTROL STATION (CCS)**—The main operating station from which a majority of the engineering plant machinery can be controlled and monitored.

**CENTRIFUGAL FORCE**—That force that tends to drive a thing or parts of a thing outward from a center of rotation.

**CIRCUIT BREAKER (CB)**—A device used to energize/de-energize an electrical circuit and for interrupting the circuit when the current becomes excessive.

**CLASSIFICATION AND/OR TYPE**—A method of identifying and sorting various equipment and materials. For example: (1) check valve—swing, stop; (2) valve—solenoid, manual.

**CLUTCH/BRAKE ASSEMBLY**—A clutch/brake assembly for each GTE is mounted on the MRG housing to couple or decouple either or both engines to the drive train, to stop and hold the power turbine, and for shaft braking.

**COALESCE**—To grow together, unite, or fuse, as uniting small liquid particles into large droplets. This principle is used to remove water from fuel in the filter/separator.

**COHESION**—The force that causes molecules that are brought close together to stick together.

**COMPARATOR**—An instrument or machine for comparing anything to be measured with a standard instrument. Specifically, a self-contained portable pneumatic comparison-type pressure gauge tester.

**COMPONENT PARTS**—(1) The integral part of a component. (2) Individual units of a subassembly.

**COMPRESSOR DISCHARGE PRESSURE (CDP)**—Compressor discharge pressure is sensed by a pressure tap on the compressor discharge static pressure sensing line to the MFC and piped to a base-mounted transducer on the GTM.

**COMPRESSOR INLET TEMPERATURE (CIT or T<sub>2</sub>)**—The temperature of the air entering the gas turbine compressor (GTM) as measured at the front frame; one of the parameters used for calculating engine power output (torque) and scheduling combustion fuel flow and variable stator vane angle.

**COMPRESSOR INLET TOTAL PRESSURE (P<sub>t2</sub>)**—The pressure sensed by a total pressure probe mounted in the GTM compressor front frame.

**CONDENSATE**—The product of condensation (the process of reducing from one form to another and denser form, as steam to water).

**CONDITION**—The state of being of a device, such as ON-OFF, GO/NO-GO, and so forth.

**CONDUCTIVITY**—The quality or power of conducting or transmitting heat, electricity, and so forth.

**CONTROL AIR SYSTEM (COAS) ASSEMBLY**—The equipment that controls the compressed air used to operate the main clutch/brake assemblies. One control air system unit is mounted on each side of each MRG. This system is not used on the SSS clutch system.

**CONTROL MODE**—The method of system control at a given time.

**CONTROL POWER**—The power used to control or operate a component.

**CONTROL SIGNAL**—The signal applied to a device that makes corrective changes in a controlled process.

**CONTROLLABLE REVERSIBLE PITCH (CRP) PROPELLER**—A propeller whose blade pitch can be varied to control the amount of thrust in both the ahead and astern directions. (Known as controllable pitch propeller (CPP) on FFG-7 class ships.)

**CONVERTER**—A device for changing one type of signal to another (for example, alternating current to direct current).

**COULOMB'S LAW**—Also called the **LAW OF ELECTRIC CHARGES** or the **LAW OF ELECTROSTATIC ATTRACTION**. Coulomb's law states that charged bodies attract or repel each other with a force that is directly proportional to the product of their individual charges and inversely proportional to the square of the distance between them.

**CURRENT**—The movement of electrons past a reference point. The passage of electrons through a conductor. It is measured in amperes.

**CYCLE**—A complete cycle exists when the voltage in an alternating current increases from zero to a maximum point, then decreases through zero to a maximum point in the opposite direction, and returns to zero again.

**DAMAGE CONTROL CONSOLE (DCC)**—This console is located in CCS and provides monitoring for hazardous conditions (fire, high bilge levels, and so forth). It also monitors the ship's firemain and can control the fire pumps.

**DEADWEIGHT TESTER**—A hydraulic balance-type gauge tester operating on the principle of subjecting the gauge under test to a hydrostatic pressure created by applying weights to a piston of known area. The weighted piston applies pressure to a fluid, such as oil, in the cylinder, which in turn is transmitted to the gauge through a system of piping.

**DEAERATING FEED TANK (DFT)**—A device used in the waste-heat boiler (WHB) system to remove dissolved oxygen and noncondensable gases from the feedwater.

**DEAERATOR**—A device that removes air from oil (for example, the lube oil storage and conditioning assembly (LOSCA) tank which separates air from the scavenge oil).

**DEMAND DISPLAY INDICATOR (DDI)**—A numerical display that is used to read values of parameters within the engineering plant.

**DENSITY**—The quantity of matter contained in a body.

**DIFFERENTIAL PRESSURE**—The difference between two pressures measured with respect to a common basis.

**DIFFERENTIAL PRESSURE GAUGE**—A Bourdon-type gauge equipped with two Bourdon tubes so arranged as to measure the difference in pressure between two pressure lines. Bellows gauges also measure differential pressure.

**DIFFUSER**—A device that reduces the velocity and increases the static pressure of a fluid passing through a system.

**DIGITAL**—Pertaining to data in the form of digits.

**DIGITAL SIGNAL**—A signal in the form of a series of discrete quantities that have two distinct levels (for example, on/off).

**DIGITAL TO ANALOG (D/A) CONVERSION**—A conversion that produces an analog output in the form of voltage or current from a digital input.

**DIRECT CURRENT (dc)**—An electric current that flows in one direction only.

**DISTILLATE**—The fresh water that is obtained from the distilling process.

**DISTILLED WATER**—Water that has been purified through a process of evaporation and condensation.

**EDUCTOR**—A mixing tube (jet pump) that is used as a liquid pump to dewater bilges and tanks. A GTM exhaust nozzle creates an eductor effect to remove air from the enclosure.

**ELECTRIC PLANT CONTROL CONSOLE (EPCC)**—This console contains the controls and indicators used to remotely operate and monitor the generators and the electrical distribution system.

**ELECTRIC PLANT CONTROL ELECTRONICS ENCLOSURE (EPCEE)**—The EPCEE is a part of the EPCE. It contains power supplies that provide the various operating voltage required by the EPCC on the DD and CG class ships.

**ELECTRIC PLANT CONTROL EQUIPMENT (EPCE)**—The EPCE provides centralized remote control of the GTGS and electrical distribution equipment. The EPCE includes the EPCC and EPCEE and is located in CCS.

**ELECTRICAL RESISTANCE**—The opposition offered by a substance or body to the passage through it of an electric current or magnetic flux.

**ELECTRODE**—Either terminal of an electric source. An electrode may be a wire, a plate, or other electricity-conducting object.

**ELECTROLYTE**—A solution of a substance that is capable of conducting electricity. An electrolyte may be in the form of a liquid or paste.

**ELECTROMOTIVE FORCE**—That which moves or tends to move electricity.

**ELECTRONIC GOVERNOR (EC)**—A system that uses an electronic control unit with an electrohydraulic governor actuator to control and regulate engine speed.

**EMERGENCY**—An event or series of events in progress which will cause damage to equipment unless immediate, timely, and correct procedural steps are taken.

**ENGINEERING CONTROL AND SURVEILLANCE SYSTEM (ECSS)**—An automatic electronic control and monitoring system using analog and digital circuitry to control the propulsion and electric plant. The ECSS consists of the PLOE, PAMCE, SCE, EPCE, and PAMISE on the DD and CG class ships.

**ENGINEERING OPERATIONAL SEQUENCING SYSTEM (EOSS)**—A two-part system of operating instructions bound in books for each watch station. It provides detailed operating procedures (EOP) and casualty control procedures (EOCC) for the propulsion plant.

**ENGINEER OFFICER**—Often referred to as the engineering officer or chief engineer.

**ENGINE ORDER TELEGRAPH (EOT)**—A nonvoice communication system provided between the command station (pilot house), CCS, and the MER.

**FAHRENHEIT SCALE**—A thermometric scale, at which, under atmospheric pressure, the boiling point is 212°F and the freezing point is 32°F above zero.

**FAIL**—The loss of control signal or power to a component. Also breakage or breakdown of a component or component part.

**FAIL POSITION**—The operating or physical position to which a device will go upon loss of its control signal.

**FATIGUE**—The tendency of a material to break under repeated strain.

**FAULT ALARM**—This type of alarm is used in the fuel control system and the DCC. It indicates that a sensor circuit has opened.

**FEEDBACK**—A value derived from a controlled function and returned to the controlling function.

**FERROUS**—Refers to metals having iron as the base metal.

**FILAMENT**—A threadlike conductor, as of carbon or metal, that is made incandescent by the passage of an electric current.

**FILTER**—(1) A device that removes insoluble contaminants from the fluid of a fluid power system. (2) A device through which gas or liquid is passed; dirt, dust, and other impurities are removed by the separating action.

**FITTINGS, PIPE**—A term applied to the connections and outlets, with the exception of valves and couplings, that are attached to pipes.

**FLAMMABLE**—A combustible material that burns easily, intensely, or quickly.

**FOOT-POUND**—A term used in torque application representing a force of 1 pound applied perpendicular to a moment arm 1 foot long.

**FREE STANDING ELECTRONIC ENCLOSURE (FSEE)**—The FSEE provides the supporting electronics and engine control interface between the GTM and the control consoles. One FSEE is located in each MER.

**FREQUENCY**—The number of cycles (as in an alternating electrical current) completed per second.



**FUEL OIL SYSTEM**—This system provides a continuous supply of clean fuel to the GTMs.

**FUEL TRANSFER AND OIL BALLAST CONTROL PANEL (FTOBCP)**—This panel is located in CCS and is used to monitor the ship's fuel tanks (FFG-7 class ships).

**FUEL SYSTEM CONTROL CONSOLE (FSCC)**—The FSCC is located in CCS and is the central station for monitoring and control of the fuel fill and transfer system on the DD and CG class ships.

**FULL POWER CONFIGURATION**—The condition in which both engines (GTEs) of a set are engaged and driving the reduction gear and propeller shaft.

**FUNCTION**—To perform the normal or characteristic action of anything, or special duty or performance required of a person or thing in the course of work.

**FUNCTIONAL COMPONENT SYSTEM**—A system of standardized units of carefully balanced combinations of material, equipment, and/or personnel. Each unit is designed to perform a specific task at an advanced base.

**GALVANOMETER**—An instrument for measuring a small electric current, or for detecting its presence or direction by the movements of a magnetic needle or of a coil in a magnetic field.

**GAS GENERATOR (CC)**—The gas-producing section of any GTE. It usually has a compressor, a combustor, a high-pressure turbine, an accessory drive system, and controls and accessories.

**GAS GENERATOR SPEED ( $N_{gg}$ )**—The speed sensed by a magnetic pickup on the transfer gearbox of the GTE.

**GAS TURBINE ENGINE (GTE)**—A gas turbine engine consists of a compressor, a combustor, a turbine, and an accessory drive system. Many variations of GTEs exist.

**GAS TURBINE GENERATOR SET (GTGS)**—The GTGS has a GTE, a reduction gearbox, and a generator.

**GAS TURBINE MODULE (GTM)**—The GTM consists of the main propulsion gas turbine unit, including the GTE, base, enclosure, shock mounting system, fire detection and extinguishing system, and the enclosure environmental control components.

**GAUGE PRESSURE**—Pressure that is measured using atmospheric pressure for zero reference.

**GENERATOR BREAKER (GB)**—The GB is used to connect a generator to its main switchboard.

**GOVERNOR DROOP MODE**—Droop mode is normally used only for paralleling with shore power. Since shore power is an infinite bus (fixed frequency), droop mode is necessary to control the load carried by the generator. If a generator is paralleled with shore power, and an attempt is made to operate it in isochronous mode instead of droop mode, the generator governor speed reference can never be satisfied because the generator frequency is being held constant by the infinite bus. If the generator governor speed reference is above the shore power frequency, the load carried by the generator will increase beyond capacity (overload) in an effort to raise the shore power frequency. If the speed reference is below the shore power frequency, the load will decrease and reverse (reverse power) in an effort to lower the shore power frequency. The resulting overload or reverse power will trip the GB.

**GOVERNOR ISOCHRONOUS MODE**—This mode is normally used for generator operation. This mode provides a constant frequency for all load conditions. When operating two (or more) generators in parallel, isochronous mode also provides equal load sharing between units.

**HAZARD ALARM**—This type of alarm is used in the fuel control system and DCC. It shows that a parameter has exceeded preset safe limits.

**HEAD TANK**—The tank located higher than other system components to provide a positive pressure to a system by gravity when the system is secured.

**HELIX**—(1) A tube or solid material (gear teeth) wrapped like threads on a screw. (2) Anything having a spiral shape. (Mathematically, a helix is the shape of the curve formed on any cylinder by a straight line in a plane that is wrapped around the cylinder, such as an ordinary screw thread.)

**HERTZ (Hz)**—A unit of frequency equal to one cycle per second.

**HIGH-PRESSURE (HP) AIR SYSTEM**—A system that is designed for a nominal operating pressure in excess of 1000 psig.

**HYDRAULIC**—Conveyed, operated, or moved by water or other liquid in motion.

**HYDRAULIC ACTUATOR**—A device that converts hydraulic pressure to mechanical movement.

**HYDRAULIC OIL POWER MODULE (HOPM)**—The HOPM is located near the MRG. It delivers pressure-regulated oil to the power oil piping and the control oil piping.

**HYDROMETER**—An instrument used to measure specific gravity. In batteries hydrometers are used to indicate the state of charge by the specific gravity of the electrolyte.

**HYDROSTATIC**—Related to liquids at rest or the pressures they exert or transmit.

**HYSTERESIS**—The inability of an elastic member to return to its original position after it has been stressed. To lag.

**INDUCTION (ELECTRICAL)**—The process by which (1) an electrical conductor becomes electrified when near a charged body, (2) a magnetizable body becomes magnetized when in a magnetic field, or (3) an electromotive force (emf) is produced in a circuit by varying the magnetic field linked with the circuit.

**INERT GAS**—A gas that has no active chemical properties.

**INFORMATION CONTROL CONSOLE (ICC)**—The ICC is part of the ECU. The ICC No. 1 is the panel used to program and run the computer. The ICC No. 2 is the tape reader used to input the program into the ECU.

**INLET GUIDE VANES (IGVs)**—The variable vanes ahead of the first stage of compressor blades of a GTE. Their function is to guide the inlet air into the GTE compressor at the optimum angle.

**INLET PLENUM**—That section for the GTE inlet air passage that is contained within the engine enclosure.

**INTEGRATED THROTTLE CONTROL (ITC)**—The ITC has control electronics located in the PACC that allow single lever control of throttle and pitch of one shaft. Two levers (one per shaft) are located at the SCC and at the PACC on the DD and CG class ships.

**INTERLOCK**—A device that prevents an action from taking place until all required conditions are met.

**JP-5**—The principal use of JP-5 is fuel for helicopters and small boats.

**KELVIN SCALE**—A thermometric scale on which the units are the same size as the Celsius scale with the zero point shifted to absolute zero. Absolute zero on the Celsius scale is  $-273.15^{\circ}$ .

**KILOWATT**—A unit of electrical power equal to 1,000 watts. (A watt is a unit of power equal to the rate of work represented by a current of 1 ampere under a pressure of 1 volt.)

**KINETIC ENERGY**—Energy in motion.

**LABYRINTH/HONEYCOMB SEALS**—This type of seal combines a rotating element and a honeycomb stationary element to form an air seal. Used in gas turbines to maintain close tolerances over a large temperature range.

**LABYRINTH/WINDBACK SEALS**—This type of seal combines a rotating element with a smooth surface stationary element to form an oil seal. This type of seal is used with an air seal with a pressurization air cavity between the two seals. Pressure in the pressurization air cavity is always greater than the sump pressure. Therefore, flow across the seal is toward the sump. This prevents oil leakage from the sump. The windback is a coarse thread on the rotating element of the oil seal which uses screw action (windback) to force any oil that might leak across the seal back into the sump.

**LEFT-HAND RULE**—(1) For generators: If the thumb, first finger, and second finger of the left hand are stretched at right angles to one another, with the thumb representing the direction of motion, the first finger representing the direction of magnetic lines of force, and the second finger representing the direction of electron flow, the relationship between the directions will then be correct for a conductor in the armature of a generator. (2) For a current-carrying wire: If the fingers of the left hand are placed around the wire in such a way that the thumb points in the direction of electron flow, the fingers will be pointing in the direction of the magnetic field.

**LIQUID FUEL VALVE (LFV)**—This valve meters the required amount of fuel for all engine operating conditions for the Allison 501-K17 GTE.

**LOAD SHEDDING**—Protects a generator from overloading by automatically dropping preselected loads when generator output reaches 100 percent.

**LOCAL CONTROL**—Start-up and operation of equipment by manual controls attached to the machinery, or by an electric panel attached to the machinery or located nearby.

**LOCAL OPERATING PANEL (LOP)**—The LOP is the local operating station for GTEs on the FFG-7 class ships. It is located in the MER and is used primarily for maintenance.

**LOCKED TRAIN**—A designation applied to a reduction gear set where when one gear is turned, all gears in the set will turn.

**LOGIC**—A method for describing the existing condition of circuits and devices that can remain at only one of two opposite conditions at a particular time, such as ON or OFF, UP or DOWN, IN or OUT.

**LUBE OIL STORAGE AND CONDITIONING ASSEMBLY (LOSCA)**—The LOSCA is mounted remotely from the GTM and is a unit with a lube oil storage tank, a heat exchanger, a scavenge oil duplex filter, and a scavenge oil check valve (all mounted on a common base). Its function is to provide the GTM with an adequate supply of cooled, clean lube oil. It also has instrumentation for remote monitoring of oil temperature, filter differential pressure, and high/low tank level alarm.

**MAIN FUEL CONTROL (MFC)**—A hydro-mechanical device on the propulsion GTE that controls  $N_{gg}$ , schedules acceleration fuel flow, deceleration fuel flow, and stator vane angle for stall-free, optimum performance over the operating range of the GTE.

**MAIN REDUCTION GEAR (MRG) ASSEMBLY**—A locked train, double reduction gear designed to reduce the rpm output of the GTE and drive the propeller shaft.

**MANUAL BUS TRANSFER (MBT)**—The MBT provides for manual selection between normal and alternate power sources.

**MASKER AIR SYSTEM**—This system disguises the sound signature of the ship and alters transmission of machinery noise to the water by emitting air from small holes in the emitter rings on the ship's hull.

**MASS**—The measure of the quantity of matter contained in a body.

**MILITARY STANDARDS (MILSTDs)**—A formalized set of standards for supplies, equipment, and design work purchased by the United States Armed Forces.

**MOMENT ARM**—The length of a torque wrench from the center of pivot to the point where force is applied.

**MONITORING POINT**—The physical location at which any indicating device displays the value of a parameter at some control station.

**MOST REMOTE BEARING**—The bearing located at the hydraulically most remote point in the system.

**MOTOR**—(1) A rotating machine that transforms electrical energy into mechanical energy. (2) An actuator that converts fluid power to rotary mechanical force and motion.

**MOTOR CONTROLLER**—A device or group of devices that governs, in some predetermined manner, the operation of the motor to which it is attached.

**MULTIPLEXING**—A system of transmitting two or more messages or signals over a common circuit.

**NONFERROUS METAL**—Metal that is composed primarily of a metallic element, or elements other than iron.

**NOZZLE**—A taper or restriction used to speed up or direct the flow of gas or liquid.

**OCCUPATIONAL STANDARDS (OCC-STDs)**—Requirements that describe the work of each Navy rating.

**OHM**—The unit of electrical resistance.

**OHM'S LAW**—A fundamental electrical law which expresses the relationship between voltage, current, and resistance in dc circuits or voltage, current, and impedance in ac circuits.

**OIL DISTRIBUTION (OD) BOX**—This box is located at the forward end of each MRG assembly. It directs power oil from the HOPM to the propeller hub through the shaft bore. The OD box also establishes propeller pitch by using control oil from the HOPM to position the valve rod, which extends through the shaft to the hub.

**ONE-LINE SCHEMATIC**—A drawing of a system using only one line to show the tie-in of various components; for example, the three conductors needed to transmit three-phase power are represented by a single line.

**OPEN LOOP**—A system having no feedback.

**OPERATING CHARACTERISTICS**—The combination of a parameter and its set point.

**ORIFICE**—A circular opening in a flow passage that acts as a flow restriction.

**OSCILLATOR**—A fluidic device that incorporates a feedback system and generates a frequency determined by such factors as viscosity of the fluid passing through the device. This device can be used as a frequency generator or as a temperature/viscosity sensor.

**PACKING**—A class of seal that provides a seal between two parts of a unit that move in relation to each other.

**PARAMETER**—A variable, such as temperature, pressure, flow rate, voltage, current, or frequency that may be indicated, monitored, checked, or sensed in any way during operation or testing.

**PASCAL'S PRINCIPLE**—Pressure applied on a confined fluid is transmitted undiminished in every direction.

**PERMANENT MAGNET ALTERNATOR (PMA)**—The PMA is mounted on the generator shaft extension of each GTGS and supplies speed sensing and power to the EG. The PMA also supplies initial generator excitation.

**PHASE DIFFERENCE**—The time in electrical degree by which one wave leads or lags another.

**PIPE**—A tube or hollow body for conducting a liquid or gas. Dimensions of a pipe are designated by nominal (approximate) outside diameter (OD) and wall thickness.

**PIPING**—An assembly of pipe or tubing, valves, and fittings that forms the transferring part of a system.

**PITCH**—A term applied to the distance a propeller will advance during one revolution.

**POLARITY (ELECTRICAL)**—The particular state (positive or negative) of a body with reference to the two poles.

**POPPET-TYPE CHECK VALVE**—A valve that moves into and from its seat to prevent oil from draining into the GTGS when the engine is shut down.

**PORTABLE STEERING CONTROL UNIT (PSCU)**—The PSCU is a portable steering control unit that can be mounted on a bridge wing.

**POTABLE WATER**—Water that is suitable for drinking. The potable water system supplies scuttlebutts, sinks, showers, sculleries, and galleys, as well as provides makeup water for various freshwater cooling systems.

**POTENTIAL**—The amount of charge held by a body as compared to another point or body. Usually measured in volts.

**POTENTIAL ENERGY**—(1) Energy at rest; stored energy. (2) The energy a substance has because of its position, its condition, or its chemical composition.

**POTENTIOMETER**—A variable resistance unit having a rotating contact arm that can be set at any desired point along a resistance element.

**POUNDS PER SQUARE INCH (psi)**—A unit of pressure.

**POUNDS PER SQUARE INCH ABSOLUTE (psia)**—A unit of pressure.

**POUNDS PER SQUARE INCH DIFFERENTIAL (psid)**—A unit of pressure. Also known as delta ( $\Delta$ ) pressure.

**POUNDS PER SQUARE INCH GAUGE (psig)**—A unit of pressure.

**POWER LEVER ANGLE (PLA)**—A rotary actuator mounted on the side of the GTE fuel pump and its output shaft lever. It is mechanically connected to the MFC power lever. The PLA actuator supplies the torque to position the MFC power lever at the commanded rate.

**POWER ON RESET**—A signal generated by each electronics enclosure when it is energized. This signal preconditions electronic circuitry in the control console (whose power is supplied by that electronics enclosure) to a known state for operational purpose during application of power to the console.

**POWER SUPPLY**—The module that converts the 115-volt, 60-hertz incoming power to ac or dc power at a more suitable voltage level.

**POWER TAKEOFF (PTO)**—The drive shaft between the GTGS gas turbine engine and the reduction gear. Transfers power from the gas turbine to the reduction gear to drive the generator.

**POWER TURBINE (PT)**—The GTE turbine that converts the GG exhaust into energy and transmits the resulting rotational force via the attached output shaft.

**POWER TURBINE INLET TEMPERATURE ( $T_{5.4}$ )**—The temperature sensed by thermocouples installed in the GTE midframe.

**POWER TURBINE INLET TOTAL PRESSURE ( $P_{t5.4}$ )**—The pressure sensed by five total pressure probes located in the GTE turbine midframe and piped to a transducer on the bottom of the GTM.

**POWER TURBINE SPEED ( $N_{pt}$ )**—The speed sensed by magnetic pickups in the GTE turbine rear frame.

**PRAIRIE AIR SYSTEM**—This system emits cooled bleed air from small holes along the leading edges of the propeller blades. The resulting air bubbles disturb the thrashing sound so identification of the type of ship through sonar detection becomes unreliable.

**PRESSURE**—Pressure is force per unit of area, usually expressed as psi.

**PRESSURE FEED SYSTEM**—A system in which pressure (rather than gravity) is used to maintain flow.

**PRIME MOVER**—(1) The source of motion—as a gas turbine engine. (2) The source of mechanical power used to drive a pump or compressor. (3) The source of mechanical power used to drive the rotor of a generator.

**PRINTED CIRCUIT BOARD (PCB)**—(1) An electronic assembly mounted on a card, using etched conductors. Also called printed wire board (PWB). (2) Devices usually plugged into receptacles that are mounted in modules.

**PRIORITY**—Order established by relative importance of the function.

**PROPELLER**—A propulsive device consisting of a boss or hub carrying two or more radial blades. Also called a SCREW.

**PROPULSION AND AUXILIARY CONTROL CONSOLE (PACC)**—This console is located in CCS and is part of the PAMCE. It contains the electronic equipment capable of controlling and monitoring both propulsion plants and auxiliary equipment on a DD or CG class ship.

**PROPULSION AND AUXILIARY CONTROL ELECTRONICS ENCLOSURE (PACEE)**—This enclosure is located in CCS and has the electronics that supply power to the PACC on a DD or CG class ship.

**PROPULSION AND AUXILIARY MACHINERY CONTROL EQUIPMENT (PAMCE)**—This equipment is located in CCS, is part of the ECSS, and includes the PACC and PACEE. This equipment provides centralized control and monitoring of both main propulsion plants and auxiliary machinery on a DD or CG class ship.

**PROPULSION AUXILIARY MACHINERY INFORMATION SYSTEM EQUIPMENT (PAMISE)**—This equipment is located in CCS and is part of the ECSS. This equipment receives, evaluates, and logs the engineering plant performance, status, and alarm state. The PAMISE contains the CISE and S/CE No. 1 on a DD or CG class ship.

**PROPULSION CONTROL CONSOLE (PCC)**—This is the main engine control console in CCS on a FFG-7 class ship. It is used for starting, stopping, and controlling the GTEs and propeller shaft.

**PROPULSION LOCAL CONTROL CONSOLE (PLCC)**—The PLCC is located in each engine room and is part of the PLOE. It has controls and indicators necessary for operator's control of one main propulsion plant and its supporting auxiliaries on a DD or CG class ship.

**PROPULSION LOCAL CONSOLE ELECTRONICS ENCLOSURE (PLCEE)**—The PLCEE is located in each engine room and is part of the PLOE. It has the electronics that supply power to the FSEE and PLCC on a DD or CG class ship.

**PROPULSION LOCAL OPERATING EQUIPMENT (PLOE)**—The PLOE is located in each engine room and is part of the ECSS. It includes the PLCC and PLCEE. The PLOE provides for local control and monitoring of the main propulsion GTE and the associated auxiliary equipment on a DD or CG class ship.

**PUMP**—(1) A device that converts mechanical energy into fluid energy. (2) A device that raises, transfers, or compresses fluids or gasses.

**PUMP CAPACITY**—The amount of fluid a pump can move in a given period of time, usually stated in gallons per minute (gpm).

**PUSH-BUTTON SWITCH INDICATOR**—A panel-mounted device that has both switch contacts and indicating lights. The contacts are actuated by depressing the device face. The indicator lights are labeled and wired for indicating alarm or status.

**PYROMETER**—An instrument for measuring temperatures by the change of electric resistance, the production of a thermoelectric current.

**RECEIVER**—(1) A container in which compressed gas is stored to supply pneumatic power. (2) A reservoir for pressure refrigerant.

**REDUCER**—(1) Any coupling or fitting that connects a large opening to a smaller pipe or hose. (2) A device that reduces pressure in a fluid (gas or liquid) system.

**REFERENCE DESIGNATION**—A combination of letters and numbers to identify parts on electrical and electronic drawings. The letters designate the type of part, and the numbers designate the specific part. For example: Reference designator R-12 indicates the 12th resistor in a circuit.

**REFERENCE SIGNAL**—A command signal that requests a specific final condition.

**RELATIVE HUMIDITY**—The ratio of the amount of water vapor in the air at a given temperature to the maximum capacity of water vapor in the air at the same temperature.

**RELAY**—A magnetically operated switch that makes and breaks the flow of current in a circuit.

**REMOTE MANUAL OPERATION**—Human operation of a process by manual manipulation of loading signals to the final control elements.

**RESISTANCE**—The opposition to the flow of current caused by the nature and physical dimensions of a conductor.

**RESISTANCE TEMPERATURE DETECTOR (RTD)**—These temperature sensors work on the principle that as temperature increases, the conductive material exposed to this temperature increases its electrical resistance.

**RESISTANCE TEMPERATURE ELEMENT (RTE)**—Same as RTD.

**RESISTOR**—A device possessing the property of electrical resistance.

**RHEOSTAT**—A variable resistor having one fixed and one moveable terminal.

**RPM AND PITCH INDICATOR UNIT (RPIU)**—This unit is mounted in the pilot house and is part of the SCE. It is identical to the BWDU except that it also displays port and starboard CRP propeller pitch on a DD or CG class ship.

**SCAVENGE PUMP**—A pump used to remove oil from a sump and return it to the oil supply tank.

**SCHEMATIC DIAGRAM**—A diagram using graphic symbols to show how a circuit functions electrically.

**SECURE**—(1) To make fast or safe. (2) The order given on completion of a drill or exercise. (3) The procedure followed with any piece of equipment that is to be shut down.

**SECURED PLANT CONFIGURATION (MODE)**—The condition in which engines of a set are disengaged from the reduction gear/propulsion shaft on a DD or CG class ship.

**SELECTOR SWITCH**—Usually a rotary-type switch with more than two line connections. The selector switch permits the connection (by a jack outlet) of a permanently connected handset to any other wired-in circuit. In some stations, where only two circuits are involved, a double-throw toggle switch is normally used.

**SENSING ELEMENT OR SENSOR**—The part of an instrument that first takes energy from the measured medium to produce a condition representing the value of the measured variable.

**SENSING POINT**—Physical and/or functional point in a system at which a signal may be detected or monitored in an automatic operation.

**SENSITIVITY**—The smallest change in the value of a variable being measured to which the instrument will respond.

**SENSOR**—A component that senses physical variables and produces a signal to be observed or to actuate other elements in a control system. Temperature, pressure, sound, and position sensors are examples.

**SEQUENCE VALVE**—An automatic valve in a fluid power system that causes one actuation to follow another in definite order.

**SEQUENTIALLY**—In a predesigned sequence, not necessarily in numerical order.

**SERIAL DATA BUS**—A major communication link between ship control equipment, PAMCE, and PLOE. The bus is time-shared between the consoles. Control and status information is exchanged in the form of serial data words on a DD or CG class ship.

**SERVICE TANKS**—The service tanks that contain purified fuel from the storage tanks.

**SET POINT**—The numerical value of a parameter at which an alarm is actuated.

**SHELL INSERT BEARING**—A bearing in which the wearing surface is installed on a thin shell. This shell is removable from the bearing body.

**SHIM**—A thin layer of metal or other material used to true up a machine or inserted in bearings to permit adjustments after bearing wear.

**SHIP CONTROL CONSOLE (SCC)**—This console is located on the bridge. It has equipment for operator control of ship's speed and direction.

**SHIP CONTROL EQUIPMENT (SCE)**—Bridge-located equipment of the ECSS, which includes SCC, SCEEE, PCSU, BWDU, and RPIU on a DD or CG class ship.

**SHIP CONTROL EQUIPMENT ELECTRONICS ENCLOSURE (SCEEE)**—The SCEEE (located in CIC) is part of the SCE. It has power supplies that provide the various operating voltages required for the SCC, BWDU, and RPIU on a DD or CG class ship.

**SHIP'S SERVICE AIR SYSTEM (SSAS)**—This system supplies compressed air at 150 psig to a majority of the ship's pneumatically operated equipment.

**SHIP'S SERVICE DIESEL GENERATOR (SSDG)**—The SSDG is the main source of electrical power for a ship. It uses a diesel engine as the prime mover for the generator.

**SHIP'S SERVICE GAS TURBINE GENERATOR (SSGTG)**—The SSGTG is the main source of electrical power for a ship. It uses a gas turbine engine as the prime mover for the generator.

**SHORT CIRCUIT**—A low resistance connection between two points of different potential in a circuit.

**SHUTTLE VALVE**—A valve that is used to direct fluid automatically from either the normal source or an alternate source to the actuator.

**SIGNAL CONDITIONING ENCLOSURE (S/CE)**—A part of the PAMISE that provides the major input interface between the propulsion plant machinery and the ECSS control consoles. The S/CE accepts inputs from the plant machinery and outputs normalized signals to the ECSS control consoles. It also has alarm detection and alarm output circuitry. One S/CE is located in each main engine room and one is part of the CISE (located in CCS) on a DD or CG class ship.

**SOLID STATE**—A class of electronics components, such as transistors, diodes, integrated circuits, silicon controlled rectifiers, and so forth.

**SPECIFIC GRAVITY**—The ratio of the weight of a given volume of any substance to the weight of an equal volume of distilled water. Since the distilled water weighs approximately 62.4 pounds per cubic foot, any substance which weighs less than this has a specific gravity of less than one and will float on water. Any substance of greater weight per cubic foot has a specific gravity of more than one and will sink. Specific gravity of gases is based in a like manner on the weight of air.

**SPECIFIC HEAT**—The amount of heat required to raise the temperature of 1 pound of a substance 1°F. All substances are compared to water, which has a specific heat of 1 BTU/lb/°F.

**SPLIT PLANT CONFIGURATION (MODE)**—The condition in which only one engine of a set is driving the reduction gear/propulsion shaft.

**STERN TUBE**—(1) The bearing supporting the propeller shaft where it emerges from the ship. (2) A watertight enclosure for the propeller shaft.

**STERN TUBE FLUSHING WATER**—Water circulated through the stern tube from inboard to prevent accumulation of debris in the stern tube while the ship is at rest or backing down.

**STRAIN**—The deformation of a material body under the action of applied forces (stress).

**STRIPPING SYSTEM**—A system provided to strip all petroleum tanks of water and sediment.

**STUFFING BOX**—(1) A chamber and closure with manual adjustment for a sealing device. (2) A device to prevent fluid leakage between a moving and a fixed part in a steam engineering plant. (3) A fitting designed to permit the free passage or revolution of a rod or a pipe while controlling or preventing the passage by it of water, steam, and so forth.

**STUFFING TUBE**—A packed tube that makes a watertight fitting for a cable or small pipe passing through a bulkhead.

**SUMMARY ALARM/FAULT**—An indicator at a console that indicates to an operator that one of several abnormal conditions has occurred on a certain piece of equipment.

**SYNCHRO SELF SHIFTING (SSS) CLUTCH**—The SSS clutch is a fully automatic, freewheel device that transmits power through gear-toothed elements.

**SYNCHRONOUS**—Happening at the same time.

**SYSTEM**—A grouping of components or equipment joined to serve a common purpose.

**SYSTEM INTERRELATION**—Specific individual operations in one system affecting the operation in another system.

**TACHOMETER GENERATOR**—A device for converting rotational speed into an electrical quantity or signal.

**TAIL SHAFT**—The aft section of the shaft that receives the propeller.



**TANK LEVEL INDICATOR (TLI)**—A hydrostatic-type tank gauge, usually operating on the principle of balancing a head of liquid in a tank against a column of mercury, or on the balanced hydraulic principle employing a float-actuated remote reading dial gauge. It is used to monitor the fluid level of a tank.

**TEST POINT**—A position in a circuit where instruments can be inserted for test purposes.

**THERMAL ENERGY**—Energy contained in or derived from heat.

**THERMOCOUPLE**—(1) A bimetallic device capable of producing an electromotive force roughly proportional to temperature differences on its hot and cold junction ends. (2) A junction of two dissimilar metals that produces a voltage when heated.

**THERMOCOUPLE PYROMETER**—A temperature measuring instrument using the change of electric resistance of a conductor when heated to indicate the temperature being measured.

**THRUST BEARING**—Bearings that limit the axial (longitudinal) movement of the shaft.

**TOLERANCE**—The allowable deviation from a specification or standard.

**TORQUE**—A force or combination of forces that produce or tends to produce a twisting or rotary motion.

**TRANSDUCER**—(1) A device that converts a mechanical input signal into an electrical output signal. (2) Generally, a device that converts energy from one form into another, always retaining the characteristic amplitude variations of the energy converted.

**TRANSFORMER**—A device composed of two or more coils, linked by magnetic lines of force, used to transfer electrical energy from one circuit to another. Also, an electrical device used to step up or step down an ac voltage.

**TURBINE INLET TEMPERATURE (TIT)**—The GTGS turbine inlet temperature on the Allison 501-K17. Known as  $T_{5.4}$  for an LM2500 GTE.

**TURBINE OVERTEMPERATURE PROTECTION SYSTEM (TOPS)**—A system used to protect a surviving generator from overload in the event of another generator failure on a DD or CG class ship.

**TURNING GEAR**—An electric motor-driven gear arrangement that slowly rotates idle propulsion shafts and main reduction gears.

**UNINTERRUPTIBLE POWER SUPPLY (UPS) SYSTEM**—Critical ship control systems have a UPS as an emergency power source. The UPS is used to maintain operations during any interruption of the normal power source.

**UNIT**—A value, quantity, or magnitude in terms of which other values, quantities, or magnitudes are expressed (for example, yard, pound, gallon).

**VACUUM**—Pressure less than atmospheric pressure.

**VALVE**—A mechanism that can be opened or closed to control the flow of a liquid, gas, or vapor from one place to another place.

**VARIABLE STATOR VANE (VSV)**—Compressor stator vanes that are mechanically varied to provide optimum, stall-free compressor performance over a wide operating range.

**VELOCITY**—The rate of motion in a particular direction. The velocity of fluid flow is usually measured in feet per second.

**VISCOSIMETER**—A device that determines the viscosity of a given sample of oil.

**VISCOSITY**—The internal resistance of a fluid which tends to prevent it from flowing.

**VOLT**—The unit of electrical potential.

**VOLTAGE**—The electric potential difference, expressed in volts.

**VOLTMETER**—An instrument for measuring in volts the difference of potential between different points of an electrical circuit.

**VOLUME**—The amount of space that matter occupies.

**WATCH STATION**—Duties, assignments, or responsibilities that an individual or group of individuals may be called upon to carry out. Not necessarily a normally manned position with a watch bill assignment.

**WATT**—The unit of electric power equal to the rate of work represented by a current of 1 ampere under a pressure of 1 volt.

**WATTMETER**—An instrument for measuring electric power in watts.

**WEIGHT**—The force of gravity exerted on an object.



## APPENDIX II

# ABBREVIATIONS AND ACRONYMS

This appendix is a listing of the abbreviations and acronyms used in this text. Although this is an extensive listing, it is not an all-inclusive list of abbreviations and acronyms used by the Gas Turbine Systems Technicians. The *GSE3/GSM3*, NAVEDTRA 10564, volume 2, will also have an appendix II with abbreviations and acronyms used in the text. However, this list will help form a basis for your qualification under the PQS system and allow for rapid access to terms used by Gas Turbine Systems Technicians.

### A

**ABT**—automatic bus transfer

**ac**—alternating current

**AFFF**—aqueous film forming foam

**amp-hr**—ampere-hours

**AMR**—auxiliary machinery room

**APD**—automatic paralleling device

### B

**BS&W**—bottom sediment and water

### C

**°C**—degree Centigrade

**CB**—circuit breaker

**CCS**—central control station

**cfm**—cubic feet per minute

**CLEP**—College Level Examination Program

**COAS**—control air system

**CPP**—controllable pitch propeller

**CPR**—cardiopulmonary resuscitation

**CBP**—controllable reversible pitch

**CSMP**—Current Ship's Maintenance Project

**CT**—current transformer

### D

**db**—decibel

**dc**—direct current

**DDI**—demand display indicator

**DFT**—deaerating feed tank

**DSP**—disodium phosphate

### E

**ECS**—electronics control station

**ECSS**—engineering control and surveillance system

**EDO**—engineering duty officer

**EDORM**—Engineering Department Organization and Regulations Manual

**EM**—Electrician's Mate

**emf**—electromotive force

**EN**—Engineman

**EOCC**—engineering operational casualty control

**EOOW**—engineering officer of the watch

**EOP**—engineering operational procedures

**EOSS**—Engineering Operational Sequencing System

**EPCC**—electric plant control console

**epm**—equivalence per million

**ER**—engine room

**ESO**—educational services officer

## F

**°F**—degree Fahrenheit

**FMS**—final multiple score

**FOD**—foreign object damage

**FSEE**—free standing electronic enclosure

**FT**—Fire Control Technician

**ft-lb**—foot-pound

## G

**gpm**—gallons per minute

**GS**—Gas Turbine Systems Technician

**GSE**—Gas Turbine Systems Technician (Electrical)

**GSM**—Gas Turbine Systems Technician (Mechanical)

**GTE**—gas turbine engine

**GTG/GTGS**—gas turbine generator/gas turbine generator set

**GTM**—gas turbine module

## H

**HOPM**—hydraulic oil power module

**HP**—high pressure

**hp**—horsepower

**HPAC**—high-pressure air compressor

**HS**—high speed

**Hz**—hertz

## I

**IC**—Interior Communications Electrician

**ID**—inside diameter

**in.lb**—inch-pound

**in.H<sub>2</sub>O**—inches of water

**in.Hg**—inches of mercury

**IPS**—internal pipe size

**IR**—infrared

## K

**K**—Kelvin

**kΩ**—kilohms

**kW**—kilowatt

## L

**lb-ft**—pound-feet

**lb/hr**—pounds per hour

**lb-in**—pound-inch

**LFV**—liquid fuel valve

**LMET**—Leadership, Management, and Education Training

**LOCOP**—local operating panel (DD, DDG, and CG)

**LOP**—local operating panel (FFG)

**LP**—low pressure

**LPAC**—low-pressure air compressor

**LS**—low speed

**LSB**—line shaft bearing

**lube**—lubricating

**LVP**—low-voltage protection

**LVR**—low-voltage release

**LVRE**—low-voltage release effect

## M

**mA**—milliamperes

**MBT**—manual bus transfer

**MDS**—maintenance data system

**MER**—main engine room

**mg/l**—milligram per liter

**MILSPEC**—military specification

**MILSTD**—military standard

**MRC**—maintenance requirement card

**MRG**—main reduction gear

## N

**NATO**—North Atlantic Treaty Organization

**NAVEDTRA**—Naval Education and Training

**NAVSEA**—Naval Sea Systems Command

**NAVSHIPS**—Naval ships (drawings)

**NAVSTD**—naval standard

**NEC**—Naval Enlisted Classification Code

**NEETS**—Navy Electricity and Electronics Training Series

**NETPMSA**—Naval Education and Training Program Management Support Activity

**NRTC**—nonresident training course

**NSTM**—*Naval Ships' Technical Manual*

## O

**OCCSTD**—occupational standard

**OD**—outside diameter

**OD BOX**—oil distribution box

**OOD**—officer of the deck

## P

**PA**—prairie air

**PACC**—propulsion and auxiliary control console

**PAR**—Personnel Advancement Requirement

**PCB**—printed circuit board

**PCC**—propulsion control console

**PLCC**—propulsion local control console

**PMA**—performance mark average

**PMS**—Planned Maintenance System

**ppm**—parts per million

**PQS**—Personnel Qualification Standards

**psfa**—pounds per square foot absolute

**psi**—pounds per square inch

**psia**—pounds per square inch absolute

**psig**—pounds per square inch gauge

**PT**—power turbine

**P<sub>15.4</sub>**—power turbine total inlet pressure

## R

**rpm**—revolutions per minute

**RSG**—readiness support group

**RTD**—resistance temperature detector

**RTE**—resistance temperature element

## S

**SAT**—Scholastic Aptitude Test

**SCC**—ship control console

**S/CE**—signal conditioning enclosure

**SDI**—ship drawing index

**SIMA**—shore intermediate maintenance activity

**SORM**—Standard Organization and Regulations of the U.S. Navy

**SS**—ship's service

**SSAS**—ship's service air system

**SSDG**—ship's service diesel generator

**SSGTG**—ship's service gas turbine generator

**SSS**—synchro-self-shifting

**SWBD**—switchboard

## T

**TIT**—turbine inlet temperature

**TLI**—tank level indicator

**TRAMAN**—training manual

**TSP**—trisodium phosphate

**T<sub>5.4</sub>**—power turbine inlet temperature

## U

**UPS**—uninterruptible power supply

**UV**—ultraviolet

## V















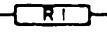





















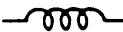
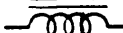



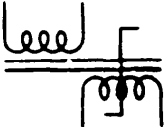

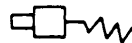







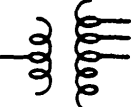

**vom**—volt-ohm-milliammeter

## W













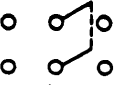
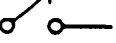



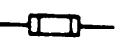



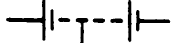
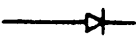

**WHB**—waste-heat boiler

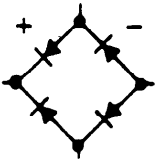
**APPENDIX III**  
**ELECTRICAL SYMBOLS**

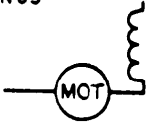
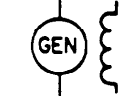
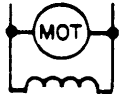

























| SHIPBOARD SYMBOLS   |  | GRAPHIC SYMBOLS  |
|---|--|--|
| <b>APPLIANCES; MISCELLANEOUS WIRING (GENERAL)</b><br>  | <b>CONTROLLER, MOTOR (GENERAL)</b><br><br>BUILDUP EXAMPLES<br>CONTROLLER WITH LOW-VOLTAGE RELEASE, RECLOSES UPON RETURN OF POWER<br><br>CONTROLLER WITH LOW-VOLTAGE PROTECTION, REMAINS OPEN UPON RETURN OF POWER<br>   | <b>RESISTORS</b><br> OR <br>GENERAL TAPPED <br>ADJUSTABLE TAP <br>CONTINUOUSLY VARIABLE <br>NONLINEAR    |
| <b>BOXES, GENERAL</b><br><br><b>BRANCH</b> <br><b>CONNECTION</b> <br><b>DISTRIBUTION</b> <br><b>JUNCTION</b>   | <b>FANS</b><br><b>FAN, PORTABLE BRACKET</b><br><br><b>FAN, OVERHEAD</b><br>  | <b>CAPACITORS</b><br>  <br>FIXED VARIABLE TRIMMER<br> <br>GANGED SHIELDED<br> <br>SPLIT-STATOR FEED-THROUGH                 |
| <b>BUS TRANSFER EQUIPMENT</b><br><b>NONAUTOMATIC OR PUSH BUTTON CONTROL</b><br><b>AC</b> <br><b>DC</b>    | <b>HEATERS</b><br><b>HEATER, GENERAL</b><br><br><b>HEATER, PORTABLE RADIANT</b><br>  | <b>INDUCTIVE COMPONENTS</b><br><b>GENERAL</b> <br><b>MAGNETIC CORE</b> <br><b>TAPPED</b> <br><b>ADJUSTABLE</b> <br><b>ADJUSTABLE OR CONTINUOUSLY ADJUSTABLE</b> <br><b>SATURABLE CORE REACTOR</b>  |
| <b>COMMUNICATION EQUIPMENT</b><br><b>BOX, SWITCH, TELEPHONE</b><br><br><b>JACKS</b> <br><b>PLUGS, TELEPHONE</b><br>  | <b>LIGHTING UNITS</b><br><b>BULKHEAD</b> <br><b>BULKHEAD, BERTH</b> <br><b>HAND LANTERN</b> <br><b>NAVIGATIONAL</b> <br><b>NIGHT FLIGHT</b> <br><b>OVERHEAD</b> <br><b>PORTABLE</b> <br><b>OVERHEAD, FLUORESCENT</b><br> | <b>TRANSFORMERS</b><br><b>GENERAL</b> <br><b>MAGNETIC CORE TRANSFORMER</b> <br><b>AUTOTransformer</b> <br><b>WITH TAPS, SINGLE-PHASE</b>   |
| <b>RECEPTACLE OR OUTLET</b><br><br><b>SWITCH</b><br><b>PUSH BUTTON</b> <br><b>ON-OFF</b> <br><b>SELECTOR</b><br><b>CIRCUIT LETTER</b> <br><b>PANEL OR BULKHEAD</b> <br><b>NUMBER OF SECTIONS</b> <br><b>SNAP</b> <br><b>TRANSFER</b>  |  |  |

## GRAPHIC SYMBOLS

|   |  |   |
|---|--|---|
| <p><b>SWITCHES</b></p> <p>GENERAL (SINGLE THROW) </p> <p>GENERAL (DOUBLE THROW) </p> <p>TWO POLE DOUBLE THROW SWITCH </p> <p>KNIFE SWITCH </p> <p>PUSH-BUTTON (MAKE) </p> <p>PUSH-BUTTON (BREAK) </p> <p>PUSH-BUTTON TWO CIRCUIT </p> <p><b>CIRCUIT PROTECTORS</b></p> <p>FUSE </p> <p>FUSE OR OVERLOAD </p> | <p><b>CIRCUIT AIR BREAKERS</b></p> <p>SWITCH </p> <p>THERMAL </p> <p>GANGED </p> <p><b>BATTERIES</b></p> <p>ONE CELL </p> <p>MULTICELL </p> <p>TAPPED MULTICELL </p> <p>(LONG LINE IS ALWAYS POSITIVE)</p> <p><b>RECTIFIERS</b></p> <p>GENERAL </p> <p>SEMICONDUCTOR </p> <p>(ELECTRON FLOW IS AGAINST THE ARROW)</p> <p>FULL WAVE BRIDGE TYPE </p> | <p><b>ROTATING MACHINES</b></p> <p style="text-align: center;">  (MOT)      (GEN)<br/>             MOTOR     GENERATOR         </p> <p><b>TYPES OF WINDINGS</b></p> <p>SERIES </p> <p>SEPARATELY EXCITED </p> <p>SHUNT </p> <p>DYNAMOTOR </p> <p><b>WINDING SYMBOLS</b></p> <p>SINGLE-PHASE </p> <p>TWO-PHASE </p> <p>THREE-PHASE (WYE) </p> <p>THREE-PHASE (DELTA) </p> |
|---|--|---|























































## ARCHITECTURAL SYMBOLS

|  |  |  |
|--|--|--|
| <p>SINGLE RECPT. OUTLET </p> <p>DUPLEX RECPT. </p> <p>CEILING INCAN. LIGHT </p> <p>SINGLE FLUOR. FIXTURE </p> <p>CONTINUOUS ROW FLUOR. FIXTURE </p> <p>EXIT LIGHT (CEILING) </p> <p>EXIT LIGHT (WALL) </p> <p>JUNCTION BOX </p> <p>CLOTHES DRYER OUTLET  CD</p> | <p>FLOOR DUPLEX RECPT. OUTLET </p> <p>SINGLE POLE SWITCH S </p> <p>THREE-WAY SWITCH S<sub>3</sub> </p> <p>SWITCH FOR LOW-VOLTAGE SYSTEM SL </p> <p>THERMOSTAT T </p> <p>PUSH-BUTTON MOTOR CONTROLLER </p> <p>WIRE CONCEALED IN FLOOR </p> <p>RECESSED PANEL </p> | <p>PUSH-BUTTON BELL OR SIGNAL </p> <p>BUZZER </p> <p>CHIME CH </p> <p>BELL TRANSFORMER BT </p> <p>WIRE CONCEALED IN WALL OR CEILING </p> <p>WIRE CONCEALED IN FLOOR </p> <p>BRANCH CIRCUIT EXPOSED </p> |
|--|--|--|



**APPENDIX IV**  
**PIPING PRINT SYMBOLS**

| PIPE FITTINGS, TYPES OF CONNECTIONS               |  | CAP  |                | STOP COCK, PLUG OR CYLINDER VALVE, 3-WAY, 3-PORT                                    |  |
|---|--|--|----------------|---|--|
| SCREWED ENDS                                      |  | COUPLING   |                | STOP COCK, PLUG OR CYLINDER VALVE, 4-WAY, 4-PORT                                    |  |
| FLANGED ENDS                                      |  | PLUG   |                | RELIEF, REGULATING, AND SAFETY VALVES   |  |
| BELL-AND-SPIGOT ENDS                              |  | REDUCER, CONCENTRIC                              |                | VALVE   |  |
| WELDED AND BRAZED ENDS                            |  | UNION, FLANGED                                   |                | GENERAL SYMBOL  |  |
| SOLDERED ENDS                                     |  | UNION, SCREWED                                   |                | ANGLE, RELIEF   |  |
| ELBOWS  |  | EXPANSION JOINT, BELLOWS                         |                | BACK PRESSURE   |  |
| FITTING   |  | EXPANSION JOINT, SLIDING                         |                | GLOBE, RELIEF   |  |
| ELBOW, 90 DEGREES                                 |  | VALVES, TYPES OF CONNECTIONS                     |                | GLOBE, RELIEF ADJUSTABLE, OR SPRING-LOADED REDUCING                                 |  |
| ELBOW, 45 DEGREES                                 |  | SCREWED ENDS                                     |                | PRESSURE REDUCING OR PRESSURE REGULATING, INCREASED ACTUATING PRESSURE CLOSES VALVE |  |
| ELBOW, OTHER THAN 90 OR 45 DEGREES, SPECIFY ANGLE |  | FLANGED ENDS                                     |                | PRESSURE REDUCING OR PRESSURE REGULATING, INCREASED ACTUATING PRESSURE OPENS VALVE  |  |
| ELBOW, LONG RADIUS                                |  | BELL-AND-SPIGOT ENDS                             |                | PRESSURE REGULATING, WEIGHT-LOADED  |  |
| ELBOW, REDUCING                                   |  | WELDED AND BRAZED ENDS                           |                | SAFETY, BOILER  |  |
| ELBOW, SIDE OUTLET, OUTLET DOWN                   |  | SOLDERED ENDS                                    |                | CHECK VALVES  |  |
| ELBOW, SIDE OUTLET, OUTLET UP                     |  | STOP VALVES                                      |                | VALVE   |  |
| ELBOW, TURNED DOWN                                |  | VALVE  | GENERAL SYMBOL | GENERAL SYMBOL  |  |
| ELBOW, TURNED UP                                  |  | ANGLE  | ANGLE          | CHECK, LIFT   |  |
| ELBOW, UNION                                      |  | GATE   | GATE           | CHECK, SWING  |  |
| TEES  |  | GATE, ANGLE                                      | GATE, ANGLE    | GLOBE, STOP CHECK   |  |
| FITTING   |  | GLOBE  | GLOBE          |   |  |
| TEE   |  | GLOBE, AIR-OPERATED, SPRING-CLOSING              |                |   |  |
| TEE, DOUBLE SWEEP                                 |  | GLOBE, DECK-OPERATED                             |                |   |  |
| TEE, OUTLET DOWN                                  |  | GLOBE, HYDRAULICALLY OPERATED                    |                |   |  |
| TEE, OUTLET UP                                    |  | STOP COCK, PLUG OR CYLINDER VALVE, 2-WAY         |                |   |  |
| TEE, SINGLE SWEEP, OR PLAIN T-Y                   |  | STOP COCK, PLUG OR CYLINDER VALVE, 3-WAY, 2-PORT |                |   |  |
| OTHER PIPE FITTINGS                               |  |  |                |   |  |
| FITTING   |  |  |                |   |  |
| BUSHING   |  |  |                |   |  |

| OTHER VALVES                    |   | BUCKET TRAP                               |   | VACUUM-PRESSURE   |   |
|---------------------------------|---|---|---|---|---|
| VALVE                           | SYMBOL  | FLUAT TRAP                                |    | THERMOMETER   |    |
| AUTOMATIC, OPERATED BY GOVERNOR |    | P TRAP                                    |    | THERMOMETER, DISTANT-READING, BARE BULB TYPE            |    |
| DIAPHRAGM                       |    | RUNNING TRAP                              |    | THERMOMETER, DISTANT-READING, SEPARATE SOCKET TYPE      |    |
| FAUCET                          |    | TRAP                                      |    | AIR CHAMBER   |    |
| FLUAT OPERATED                  |    | POWER AND HEATING PLANT EQUIPMENT         |   | BULKHEAD JOINT, EXPANSION                               |    |
| LOCK AND SHIELD                 |    | UNIT                                      | SYMBOL  | BULKHEAD JOINT, FIXED                                   |    |
| MANIFOLD                        |    | AIR EJECTOR                               |    | METER, DISPLACEMENT TYPE (OTHER THAN ELECTRICAL)        |    |
| PUMP GOVERNOR                   |    | BLOWER                                    |    | ORIFICE   |    |
| SOLENOID CONTROL                |    | BLOWER, SOOT                              |    | SEA CHEST, DISCHARGE                                    |    |
| THERMOSTATICALLY CONTROLLED     |    | BOILER, STEAM GENERATOR (WITH ECONOMIZER) |    | SEA CHEST, SUCTION                                      |    |
| STRAINERS                       |   | ENGINE, STEAM                             |    | REFRIGERATION EQUIPMENT                                 |   |
| TYPE                            | SYMBOL  | EVAPORATOR, SINGLE EFFECT                 |   | UNIT  | SYMBOL  |
| BOX STRAINER                    |    | PUMP, RECIPROCATING                       |  | COIL, PIPE  |    |
| DUPLEX OIL FILTER               |  | PUMP, ROTARY AND SCREW                    |  | COMPRESSOR (ALL TYPES)                                  |  |
| DUPLEX STRAINER                 |  | TURBINE, STEAM                            |  | CONDENSER, EVAPORATIVE                                  |  |
| STRAINER                        |  | GAUGES, THERMOMETERS, AND MISCELLANEOUS   |   | CONDENSING UNIT, AIR-COOLED                             |  |
| Y STRAINER                      |  | TYPE                                      | SYMBOL  | CONDENSING UNIT, WATER-COOLED                           |  |
| TRAPS                           |   | LIQUID LEVEL                              |  | COOLER, BRINE   |  |
| TYPE                            | SYMBOL  | PRESSURE                                  |  | SWITCH, CUT-OUT, HIGH-PRESSURE                          |  |
| AIR ELIMINATOR                  |  | VACUUM                                    |  | SWITCH, CUT-OUT, LOW-PRESSURE                           |  |
| BOILER RETURN TRAP              |  |   |   | VALVE, EVAPORATOR PRESSURE REGULATING SNAP-ACTION VALVE |  |
|                                 |   |   |   | VALVE, EXPANSION, AUTOMATIC                             |  |
|                                 |   |   |   | VALVE, EXPANSION, MANUALLY OPERATED                     |  |
|                                 |   |   |   | VALVE, EXPANSION, THERMOSTATIC                          |  |



# APPENDIX V

## METRIC SYSTEM

Table AV-1.—Decimal System Prefixes

### THESE PREFIXES MAY BE APPLIED TO ALL SI UNITS

| Multiples and Submultiples                    | Prefixes        | Symbols |
|---|-----------------|---------|
| 1 000 000 000 000 = 10 <sup>12</sup>          | tera (těr 'à)   | T       |
| 1 000 000 000 = 10 <sup>9</sup>               | giga (jì 'gà)   | G       |
| 1 000 000 = 10 <sup>6</sup>                   | mega (měg 'à)   | M*      |
| 1 000 = 10 <sup>3</sup>                       | kilo (kìl 'ò)   | k*      |
| 100 = 10 <sup>2</sup>                         | hecto (hěk 'tò) | h       |
| 10 = 10                                       | deka (děk 'à)   | da      |
| 0.1 = 10 <sup>-1</sup>                        | deci (dēs 'ĭ)   | d       |
| 0.01 = 10 <sup>-2</sup>                       | centi (sěn 'tĭ) | c*      |
| 0.001 = 10 <sup>-3</sup>                      | milli (mĭl 'ĭ)  | m*      |
| 0.000 001 = 10 <sup>-6</sup>                  | micro (mĭ 'krô) | μ*      |
| 0.000 000 001 = 10 <sup>-9</sup>              | nano (nän 'ò)   | n       |
| 0.000 000 000 001 = 10 <sup>-12</sup>         | pico (pē 'kô)   | p       |
| 0.000 000 000 000 001 = 10 <sup>-15</sup>     | femto (fěm 'tò) | f       |
| 0.000 000 000 000 000 001 = 10 <sup>-18</sup> | atto (ăt 'tò)   | a       |

\* Most commonly used



Table AV-2.—Metric Conversions

| Multiply                  | By        | To Obtain                | Multiply          | By      | To Obtain                  |
|---------------------------|-----------|--------------------------|-------------------|---------|----------------------------|
| Acres                     | 40.47     | Ares                     | Feet              | 30.48   | Centimeters                |
| Acres                     | 4.047     | Centares                 | Feet              | 0.1667  | Fathoms                    |
| Acres                     | 10        | Square Chains            | Feet              | 0.3048  | Meters                     |
| Acres                     | 43.560    | Square Feet              | Feet per Minute   | 0.01136 | Miles per Hour             |
| Acres                     | 4.840     | Square Yards             | Feet per Second   | 0.5921  | Knots                      |
| Ares                      | 0.02471   | Acres                    | Feet per Second   | 18.288  | Meters per Minute          |
| Ares                      | 100       | Centares                 | Feet per Second   | 0.6818  | Miles per Hour             |
| Ares                      | 1,076     | Square Feet              | Furlongs          | 10      | Chains                     |
| Ares                      | 119.6     | Square Yards             | Furlongs          | 660     | Feet                       |
| Barrels (U.S., dry)       | 3.281     | Bushels                  | Furlongs          | 40      | Rods                       |
| Barrels (U.S., liquid)    | 4.21      | Cubic Feet               | Furlongs          | 220     | Yards                      |
| Barrels (U.S., liquid)    | 31.5      | Gallons                  | Gallons (British) | 4.546.1 | Cubic Centimeters          |
| Board Feet (1' x 1' x 1') | 144       | Cubic Inches             | Gallons (British) | 0.1605  | Cubic Feet                 |
| Cable Lengths (U.S.)      | 120       | Fathoms                  | Gallons (British) | 277.274 | Cubic Inches               |
| Cable Lengths (U.S.)      | 720       | Feet                     | Gallons (British) | 1.2009  | Gallons (U.S.)             |
| Cable Lengths (U.S.)      | 240       | Yards                    | Gallons (British) | 4.546   | Liters                     |
| Centares                  | 10.76     | Square Feet              | Gallons (British) | 4       | Quarts (British)           |
| Centares                  | 1.196     | Square Yards             | Gallons (U.S.)    | 0.03175 | Barrels (Liquid,<br>U.S.)  |
| Centimeters               | 0.3937    | Inches                   | Gallons (U.S.)    | 3,785.4 | Cubic Centimeters          |
| Cubic Centimeters         | 0.06102   | Cubic Inches             | Gallons (U.S.)    | 0.13368 | Cubic Feet                 |
| Chains                    | 66        | Feet                     | Gallons (U.S.)    | 231     | Cubic Inches               |
| Chains                    | 100       | Links                    | Gallons (U.S.)    | 0.8327  | Gallons (British)          |
| Chains                    | 4         | Rods                     | Gallons (U.S.)    | 3.785   | Liters                     |
| Cubic Feet                | 1,728     | Cubic Inches             | Gallons (U.S.)    | 4       | Quarts (U.S.)              |
| Cubic Feet                | 0.02832   | Cubic Meters             | Gallons (U.S.)    | 15.43   | Grains                     |
| Cubic Feet                | 0.03704   | Cubic Yards              | Grams             | 0.001   | Kilograms                  |
| Cubic Feet                | 6.229     | Gallons (British)        | Grams             | 1.000   | Milligrams                 |
| Cubic Feet                | 7.481     | Gallons (U.S.)           | Grams             | 0.03527 | Ounces (Avoir-<br>du-pois) |
| Cubic Feet                | 28.316    | Liters                   | Hands             | 10.16   | Centimeters                |
| Cubic Inches              | 16.39     | Cubic Centimeters        | Hands             | 4       | Inches                     |
| Cubic Inches              | 0.0005787 | Cubic Feet               | Hectares          | 2.471   | Acres                      |
| Cubic Inches              | 0.003606  | Gallons (British)        | Hectares          | 100     | Ares                       |
| Cubic Inches              | 0.004329  | Gallons (U.S.)           | Hectoliters       | 0.1     | Cubic Meters               |
| Cubic Inches              | 0.01639   | Liters                   | Hectoliters       | 26.417  | Gallons (U.S.)             |
| Cubic Meters              | 35.31     | Cubic Feet               | Hectoliters       | 100     | Liters                     |
| Cubic Meters              | 1.308     | Cubic Yards              | Hogsheads         | 2       | Barrels (Liquid,<br>U.S.)  |
| Cubic Yards               | 27        | Cubic Feet               | Hogsheads (U.S.)  | 63      | Gallons (U.S.)             |
| Cubic Yards               | 0.7646    | Cubic Meters             | Hundredweights    | 0.508   | Quintals (Metric)          |
| Cubic Yards               | 764.6     | Liters                   | Inches            | 72      | Points                     |
| Degrees (C.) → 17.8       | 1.8       | Degrees (F.)             | Inches            | 6       | Picas                      |
| Degrees (F.) → 32         | 0.5556    | Degrees (C.)             | Inches            | 6       | Ems                        |
| Degrees                   | 0.01745   | Radians                  | Inches            | 12      | Ens                        |
| Fathoms                   | 0.00833   | Cable Lengths (U.<br>S.) | Inches            | 2.54    | Centimeters                |
| Fathoms                   | 6         | Feet                     |                   |         |                            |
| Fathoms                   | 1.8288    | Meters                   |                   |         |                            |

Table AV-3.—Metric Conversions—Continued

| Multiply          | By      | To Obtain              | Multiply                    | By      | To Obtain            |
|-------------------|---------|------------------------|-----------------------------|---------|----------------------|
| Inches            | 0.0833  | Feet                   | Miles, Nautical             | 6,076.1 | Feet                 |
| Inches            | 1,000   | Mils                   | Miles, Nautical             | 72,963  | Inches               |
| Inches            | 0.0277  | Yards                  | Miles, Nautical             | 1.8532  | Kilometers           |
| Inches of Mercury | 0.49131 | Pounds per Square Inch | Miles, Nautical             | 1,853.2 | Meters               |
| Kilograms         | 1,000   | Grams                  | Miles, Nautical             | 1.1508  | Miles, Statute       |
| Kilograms         | 2.2046  | Pounds (Avoirdupois)   | Miles, Nautical             | 1       | Minutes of Latitude  |
| Kiloliters        | 1       | Cubic Meters           | Miles, Nautical             | 2,026.8 | Yards                |
| Kiloliters        | 1.308   | Cubic Yards            | Miles per Hour (Statute)    | 88      | Feet per Minute      |
| Kiloliters        | 264.18  | Gallons (U.S.)         | Miles per Hour (Statute)    | 1.467   | Feet per Second      |
| Kiloliters        | 1,000   | Liters                 | Miles per Hour              | 0.8684  | Knots                |
| Kilometers        | 4.557   | Cable Lengths          | Miles, Statute              | 7.33    | Cable Lengths        |
| Kilometers        | 3,280.8 | Feet                   | Miles, Statute              | 5,280   | Feet                 |
| Kilometers        | 39,370  | Inches                 | Miles, Statute              | 8       | Furlongs             |
| Kilometers        | 1,000   | Meters                 | Miles, Statute              | 63,360  | Inches               |
| Kilometers        | 0.5396  | Miles, Nautical        | Miles, Statute              | 1,609.3 | Meters               |
| Kilometers        | 0.62137 | Miles, Statute         | Miles, Statute              | 0.8689  | Miles, Nautical      |
| Kilometers        | 1,093.6 | Yards                  | Miles, Statute              | 1,760   | Yards                |
| Knots             | 1.1516  | Statute Miles per Hour | Millier (See Tons - Metric) |         |                      |
| Knots             | 1.688   | Feet per Second        | Milliradians                | 206.265 | Seconds of Arc       |
| Leagues, Nautical | 25.33   | Cable Lengths          | Mils                        | 0.001   | Inches               |
| Leagues, Nautical | 5.5597  | Kilometers             | Myriameters                 | 10      | Kilometers           |
| Leagues, Nautical | 3       | Miles, Nautical        | Ounces (Avoirdupois)        | 28.3495 | Grams                |
| Leagues, Statute  | 4.8280  | Kilometers             | Pint (Liquid, U.S.)         | 4       | Gills (U.S.)         |
| Leagues, Statute  | 3       | Miles, Statute         | Pint (Liquid, Br.)          | 4       | Gills (British)      |
| Links             | 7.92    | Inches                 | Pint (Liquid, Br.)          | 0.56825 | Liters               |
| Liters            | 1,000   | Cubic Centimeters      | Pint (Liquid, U.S.)         | 0.4732  | Liters               |
| Liters            | 61.025  | Cubic Inches           | Pounds (Avoirdupois)        | 7,000   | Grains               |
| Liters            | 0.21998 | Gallons (British)      | Pounds (Avoirdupois)        | 453.59  | Grams                |
| Liters            | 0.26418 | Gallons (U.S.)         | Pounds (Avoirdupois)        | 0.4536  | Kilograms            |
| Liters            | 0.8799  | Quarts (British)       | Pounds (Avoirdupois)        | 16      | Ounces               |
| Liters            | 0.908   | Quarts (U.S., dry)     | Pounds (Avoirdupois)        | 1.2153  | Pounds (Troy)        |
| Liters            | 1.0567  | Quarts (Liquid, U.S.)  | Pounds (Troy)               | 0.8229  | Pounds (Avoirdupois) |
| Meters            | 100     | Centimeters            | Pounds per Square Inch      | 2.03537 | Inches of Mercury    |
| Meters            | 0.001   | Kilometers             | Quart (British)             | 1.1365  | Liters               |
| Meters            | 1.0936  | Yards                  | Quart (British)             | 2       | Pints (British)      |
| Meters            | 3.281   | Feet                   | Quart (Liquid, U.S.)        | 0.9463  | Liters               |
| Meters            | 39.37   | Inches                 | Quart (U.S.)                | 2       | Pints (U.S.)         |
| Meters            | 1,000   | Millimeters            | Quintals (Metric)           | 1.97    | Hundredweights       |
| Meters            | 1.0936  | Yards                  | Quintals (Metric)           | 100     | Kilograms            |
| Meters per Minute | 0.0547  | Feet per Second        |                             |         |                      |
| Meters per Second | 2.237   | Miles per Hour         |                             |         |                      |
| Microns           | 0.001   | Millimeters            |                             |         |                      |
| Miles, Nautical   | 8.44    | Cable Lengths          |                             |         |                      |

Table AV-4.—Metric Conversions—Continued

| Multiply                        | By       | To Obtain                 | Multiply              | By      | To Obtain                 |
|---------------------------------|----------|---------------------------|-----------------------|---------|---------------------------|
| Radians                         | 57.30    | Degrees                   | Square Miles, Statute | 259     | Hectares                  |
| Rods                            | 16.3     | Feet                      | Square Miles, Statute | 2.59    | Square Kilometers         |
| Rods                            | 25       | Links                     | Square Yards          | 0.8362  | Centares                  |
| Square Centimeters              | 0.1550   | Square Inches             | Square Yards          | 9       | Square Feet               |
| Square Feet                     | 0.0929   | Centares                  | Square Yards          | 1,296   | Square Inches             |
| Square Feet                     | 929      | Square Centimeters        | Tons (Long)           | 1.016   | Metric Tons               |
| Square Feet                     | 144      | Square Inches             | Tons (Long)           | 2,240   | Pounds (Avoir-<br>dupois) |
| Square Feet                     | 0.1111   | Square Yards              | Tons (Metric)         | 1,000   | Kilograms                 |
| Square Inches                   | 6.452    | Square Centimeters        | (Millier)             |         |                           |
| Square Inches                   | 0.006944 | Square Feet               | Tons (Metric)         | 2,204.6 | Pounds (Avoir-<br>dupois) |
| Square Kilometers               | 100      | Hectares                  | (Millier)             |         |                           |
| Square Kilometers               | 0.3861   | Square Miles<br>(Statute) | Tons (Short)          | 0.9072  | Metric Tons               |
| Square Meters (See<br>Centares) |          |                           | Tons (Short)          | 2,000   | Pounds (Avoir-<br>dupois) |
| Square Miles, Statute           | 640      | Acres                     | Yards                 | 91.44   | Centimeters               |
| Square Miles, Statute           | 25.900   | Ares                      | Yards                 | 0.9144  | Meters                    |

## APPENDIX VI

# LIST OF NAVY ELECTRICITY AND ELECTRONICS TRAINING SERIES

|           |   |
|-----------|---|
| Module 1  | Introduction to Matter, Energy, and Direct Current                              |
| Module 2  | Introduction to Alternating Current and Transformers                            |
| Module 3  | Introduction to Circuit Protection, Control, and Measurement                    |
| Module 4  | Introduction to Electrical Conductors, Wiring Techniques, and Schematic Reading |
| Module 5  | Introduction to Generators and Motors   |
| Module 6  | Introduction to Electronic Emission, Tubes, and Power Supplies                  |
| Module 7  | Introduction to Solid-State Devices and Power Supplies                          |
| Module 8  | Introduction to Amplifiers  |
| Module 9  | Introduction to Wave-Generation and Wave-Shaping Circuits                       |
| Module 10 | Introduction to Wave Propagation, Transmission Lines, and Antennas              |
| Module 11 | Microwave Principles  |
| Module 12 | Modulation Principles   |
| Module 13 | Introduction to Number Systems and Logic Circuits                               |
| Module 14 | Introduction to Microelectronics  |
| Module 15 | Principles of Synchros, Servos, and Gyros                                       |
| Module 16 | Introduction to Test Equipment  |
| Module 17 | Radio-Frequency Communications Principles                                       |
| Module 18 | Radar Principles  |
| Module 19 | The Technician's Handbook   |
| Module 20 | Master Glossary and Index   |
| Module 21 | Test Methods and Practices  |
| Module 22 | Introduction to Digital Computers   |



# INDEX

## A

Abbreviations and acronyms, AII-1 to AII-4  
Administration and programs, 2-1 to 2-32  
    engineering administration, 2-3 to 2-32  
    standing/night orders, 2-4 to 2-5  
    EDORM, 2-3 to 2-4  
    Engineering Operational Sequencing System, 2-26 to 2-32  
    EOSS User's Guide, 2-27  
    engineering operational casualty control, 2-32  
    engineering operational procedures, 2-27 to 2-32  
logs and records, 2-5 to 2-9  
    Automatic Bell Log, 2-9  
    Engineering Log, 2-5 to 2-8  
    Engineer's Bell Book, 2-8 to 2-9  
    equipment operating logs, 2-9  
Main Space Fire Doctrine, 2-26  
personnel qualification standards, 2-25 to 2-26  
programs, 2-9 to 2-25  
    environmental quality, 2-25  
    equipment tag-out program, 2-15 to 2-18  
    fluid management program, 2-19 to 2-24  
    gauge calibration, 2-25  
    personnel protection programs, 2-18 to 2-19  
    physical security program, 2-24 to 2-25  
    Safety Program, 2-9 to 2-15  
    valve maintenance, 2-25  
Ship's Maintenance and Material Management (3-M) Systems, 2-2 to 2-3  
    benefits of PMS, 2-3  
    Current Ship's Maintenance Project, 2-3  
    limitations of PMS, 2-3  
    purposes of PMS, 2-3

Administration and programs-Continued  
    sources of information, 2-1 to 2-2  
    drawings, 2-2  
    manufacturers' technical manuals, 2-2  
    Naval Sea Systems Command publications, 2-1 to 2-2  
Advancement requirements, 1-1 to 1-3  
A.E.L. contaminated fuel detector MK III, 3-25  
A.E.L. free water detector MK II, 3-24 to 3-25  
Air compressors, 7-17 to 7-25  
Ammeters, 5-19  
Antifriction bearings, 10-6 to 10-7  
Automatic Bell Log, 2-9  
Automatic bus transfers (ABTs), 9-17 to 9-18

## B

Batteries, 10-12 to 10-17  
Bearings, 8-6 to 8-8, 10-6 to 10-8  
Bellows element, 5-12 to 5-13  
Bernoulli's principle, 4-10 to 4-11  
Bimetallic expansion thermometer, 5-2 to 5-3  
Bimetallic steam traps, 6-14  
Blowdown valves, 7-33  
Boiler construction, 7-28 to 7-32  
Boiler water/feedwater, 2-23 to 2-24  
Bolted flange joints, 6-30  
Borescope, 3-17 to 3-20  
Bourdon-tube elements, 5-10 to 5-12  
Boyle's law, 4-9  
Brake/clutch assembly (DD and DDG class ships), 8-8 to 8-10  
Brushes, 10-8  
Bulkhead seals, 8-45 to 8-47  
Bull gear, 8-6

## C

Calipers, 3-11 to 3-13  
Centrifugal pumps, 7-2 to 7-8  
Centrifuge, 3-22 to 3-23

Chain hoists, 3-30  
 Charles's law, 4-9  
 Check valves, 6-4 to 6-5  
 Chemical treatment tank, 7-33  
 Circuit breaker maintenance, 10-9 to 10-11  
 Circuit breakers, 9-12 to 9-16  
 Command career counselor, 1-7  
 Condensate collecting system, 7-34 to 7-36  
 Cone or in-line filter, 6-21  
 Contact level sensors, 5-18  
 Contaminated drain inspection, 7-34  
 Control circuit analysis, 10-12  
 Control oil servo valve, 8-42 to 8-43  
 Control valves manifold block assembly, 8-36  
 Controllable pitch propeller systems, 8-30 to 8-44  
     control valves manifold block assembly, 8-36  
     electronic pitch control system, 8-41 to 8-44  
     hub/blade assembly, 8-31 to 8-34  
     hydraulic oil power system, 8-36 to 8-41  
     oil distribution box, 8-34 to 8-36  
     valve rod assembly, 8-34  
 Controllable reversible pitch hydraulic pump, 8-22  
 Controller troubleshooting, 10-11 to 10-12  
 Coulomb's law, 4-2  
 Cranes, 3-32  
 Current Ship's Maintenance Project, 2-3  
 Curved or conical spring lockwashers, 6-39

## D

DD, DDG, and CG lube oil systems, 8-13 to 8-16  
 Deadweight tester/gauge comparator, 3-16 to 3-17  
 Deaerating feed tank, 7-34 to 7-36  
 Dehumidifier, 8-23  
 Dehydrators, 7-25 to 7-27  
 Disassembly and reassembly of motors and generators, 10-8 to 10-9  
 Disc-type purifier, 7-15  
 Divisional training petty officer, 1-6  
 Drawings, 2-2  
 Duplex filters, 6-19

## E

EDORM, 2-3 to 2-4  
 Educational guidance, 1-6 to 1-7  
 Electrical distribution, 9-6 to 9-16

Electrical indicating instruments, 5-19 to 5-21  
 Electrical pressure measuring instruments (transducers), 5-13 to 5-16  
 Electrical symbols, AIII-1 to AIII-3  
 Electrical temperature measuring devices, 5-4 to 5-8  
     resistance temperature detectors, 5-4 to 5-5  
     resistance temperature elements, 5-5 to 5-6  
     thermocouples, 5-6 to 5-8  
 Electrical theory and mechanical theory, 4-1 to 4-20  
     electrical theory, 4-1 to 4-8  
     electrical power generation, 4-3 to 4-8  
     left-hand rule for generators, 4-8  
     methods of producing electrical power, 4-4 to 4-8  
     laws, 4-1 to 4-3  
     Coulomb's law, 4-2  
     Kirchhoff's voltage law, 4-1 to 4-2  
     law of magnetism, 4-2 to 4-3  
     Ohm's law, 4-1  
 levers/leverage, 4-15 to 4-16  
     first-class levers, 4-15 to 4-16  
     second-class levers, 4-16  
     third-class levers, 4-16  
 measurement of temperature, 4-17 to 4-19  
 mechanical theory, 4-8 to 4-15  
     energy, 4-11 to 4-15  
     energy transformation, 4-14 to 4-15  
     mechanical energy, 4-11 to 4-13  
     thermal energy, 4-13 to 4-14  
     laws and principles, 4-8 to 4-11  
     Bernoulli's principle, 4-10 to 4-11  
     Boyle's law, 4-9  
     Charles's law, 4-9  
     Newton's laws, 4-9 to 4-10  
     Pascal's law, 4-10  
     pressure definitions, 4-19 to 4-20  
 Electrolyte, mixing, 10-13  
 Electronic digital multimeters, 3-27  
 Electronic pitch control system, 8-41 to 8-44  
 Electrostatic vent fog precipitator, 8-22  
 Energy, 4-11 to 4-15  
 Engineering administration, 2-3 to 2-32  
     EDORM, 2-3 to 2-4  
     Engineering Operational Sequencing System, 2-26 to 2-32  
     logs and records, 2-5 to 2-9

Engineering administration—Continued  
 Main Space Fire Doctrine, 2-26  
 personnel qualification standards, 2-25 to 2-26  
 programs, 2-9 to 2-25  
 standing/night orders, 2-4 to 2-5

Engineering electrical equipment, 9-1 to 9-23  
 generators and motors, 9-1 to 9-6  
 generators, 9-1 to 9-2  
 motors, 9-2 to 9-6  
 polyphase motors, 9-2 to 9-4  
 single-phase motors, 9-4 to 9-6

lead-acid storage batteries, 9-23

60-hertz distribution system components, 9-6 to 9-23  
 motor controllers, 9-20 to 9-23  
 low-voltage protection, 9-21  
 low-voltage release, 9-21  
 low-voltage release effect, 9-21  
 magnetic across-the-line controllers, 9-21  
 overload relays, 9-22 to 9-23  
 two-speed control, 9-21  
 types of master switches, 9-20

power distribution components, 9-16 to 9-19  
 automatic bus transfers, 9-17 to 9-18  
 manual bus transfers, 9-18  
 transformers, 9-18 to 9-19

power panels and cable markings, 9-19 to 9-20

switchboards and panels, 9-6 to 9-16  
 circuit breakers, 9-12 to 9-16  
 control section, 9-7 to 9-10  
 distribution section, 9-11  
 power panels, 9-11  
 shore power, 9-11 to 9-12

summary, 9-23

uninterruptible power supply, 9-23

Engineering electrical equipment maintenance, 10-1 to 10-17  
 circuit breaker maintenance, 10-9 to 10-11  
 controller troubleshooting, 10-11 to 10-12  
 control circuit analysis, 10-12  
 power circuit analysis, 10-11 to 10-12

lead-acid storage batteries, 10-12 to 10-17  
 capacity, 10-14  
 charging rate, 10-15  
 charging time, 10-15  
 gassing, 10-16 to 10-17  
 mixing electrolyte, 10-13  
 rating, 10-14

Engineering electrical equipment maintenance—Continued  
 lead-acid storage batteries—Continued  
 readings when charged and discharged, 10-14  
 specific gravity, 10-12 to 10-13  
 adjusting specific gravity, 10-13  
 correcting specific gravity, 10-13  
 measuring specific gravity, 10-12 to 10-13

state of charge, 10-16

test discharge, 10-15 to 10-16

treatment of spilled acid, 10-13 to 10-14

types of charges, 10-14 to 10-15  
 emergency charge, 10-15  
 equalizing charge, 10-15  
 floating charge, 10-15  
 initial charge, 10-14  
 normal charge, 10-14 to 10-15

motors and generators, 10-5 to 10-9  
 bearings, 10-6 to 10-8  
 antifriction bearings, 10-6 to 10-7  
 friction bearings, 10-7 to 10-8

brushes, 10-8  
 brush care, 10-8  
 correct brush type, 10-8

cleaning motors and generators, 10-5 to 10-6

disassembly and reassembly of  
 motors and generators, 10-8 to 10-9

wire wrapping, 10-1 to 10-5  
 wire-wrap principles, 10-1  
 wire-wrap techniques, 10-1 to 10-5  
 advantages, 10-4  
 disadvantages, 10-4 to 10-5

Engineering Log, 2-5 to 2-8

Engineering Operational Sequencing System, 2-26 to 2-32

Engineering Support and Auxiliary Equipment, 7-1 to 7-38  
 air compressors, 7-17 to 7-25  
 classification of air compressors, 7-18 to 7-24  
 high-pressure air compressors, 7-22 to 7-24  
 low-pressure or ship's service air compressors, 7-18 to 7-22

maintenance of air compressors, 7-24

safety precautions, 7-24 to 7-25



## Engineering Support and Auxiliary Equipment—continued

- dehydrators, 7-25 to 7-27
  - desiccant air dehydrator (type II), 7-26 to 7-27
  - refrigeration air dehydrator (type I), 7-25 to 7-26
  - refrigeration and desiccant air dehydrator (type III), 7-27
- oily-water separator, 7-36 to 7-38
- pumps, 7-1 to 7-13
  - alignment of shaft and coupling, 7-11 to 7-13
  - classification of pumps, 7-2 to 7-11
    - centrifugal pumps, 7-2 to 7-8
    - jet pumps, 7-10 to 7-11
    - rotary pumps, 7-8 to 7-10
- purifiers, 7-13 to 7-17
  - general notes on purifier operations, 7-17
  - purifier classification, 7-13 to 7-17
    - disc-type purifier, 7-15
    - tubular-type purifier, 7-16 to 7-17
  - purifier operation, 7-13
- waste-heat boiler, 7-27 to 7-36
  - boiler classification, 7-28
  - boiler construction, 7-28 to 7-32
    - boiler control panel, 7-31 to 7-32
    - casing, 7-29
    - control condenser, 7-31
    - recirculation pump, 7-31
    - steam separator/water reservoir, 7-30 to 7-31
    - tube bundle, 7-29
  - feedwater control valve, 7-33
  - miscellaneous components, 7-33 to 7-36
    - blowdown valves, 7-33
    - chemical treatment tank, 7-33
    - condensate collecting system, 7-34 to 7-36
    - soot blowers, 7-33 to 7-34
  - steam pressure control, 7-32 to 7-33
    - steam dump valve, 7-33
    - steam stop valve, 7-33
- Engineer's Bell Book, 2-8 to 2-9
- Environmental quality, 2-25
- Equipment operating logs, 2-9
- Equipment tag-out program, 2-15 to 2-18

## F

- Fasteners, 6-37 to 6-40
  - locknuts, 6-38 to 6-39
  - lockwashers, 6-39 to 6-40
  - threaded locking devices, 6-37
- Feedwater and drain collecting tank, 7-34
- Feedwater control valve, 7-33
- FFG lube oil system, 8-16 to 8-17
- Filled-system thermometers, 5-3 to 5-4
- Filters and strainers, 6-15 to 6-21
  - construction of filter elements, 6-18 to 6-19
  - filter/strainer location, 6-17 to 6-18
  - filter/strainer materials, 6-18
  - filters, types of, 6-19 to 6-21
  - mesh and micron ratings, 6-15 to 6-17
- First-reduction gears, 8-5
- Fittings, 6-29 to 6-32
  - bolted flange joints, 6-30
  - flared fittings, 6-30 to 6-31
  - flareless fittings, 6-32
  - silver-brazed joints, 6-30
  - threaded joints, 6-29
  - unions, 6-30
  - welded joints, 6-30
- Flange safety shields, 6-32
- Flared fittings, 6-30 to 6-31
- Flareless fittings, 6-32
- Flexible hose assemblies, 6-24 to 6-29
- Fluid management program, 2-19 to 2-24
- Frequency counters, 3-28
- Frequency meters, 5-20
- Friction bearings, 10-7 to 10-8
- Fuel oil (F-44, JP-5), 2-21 to 2-23
- Fuel oil (F-76, Navy distillate), 2-20 to 2-21
- Full-flow filters, 6-19

## G

- Gaskets, 6-33
- Gassing, 10-16 to 10-17
- Gauge calibration, 2-25
- Gear casing, 8-4
- Gear pumps, 7-9
- Generators, 9-1 to 9-2, 10-5 to 10-9
- Glossary, AI-1 to AI-15
- Grinding-in valves, 6-12

## H

- Hand tools, 3-1 to 3-8
  - inspection mirror, 3-7
  - mechanical fingers, 3-6 to 3-7
  - screw and tap extractors, 3-6

Hand tools—Continued  
 taps and dies, 3-4 to 3-5  
 thread chasers, 3-5 to 3-6  
 wire-twister pliers, 3-1 to 3-3  
 wire-wrap hand tools, 3-8  
 wrenches, 3-3 to 3-4  
 Hand-operated ratchet lever hoists, 3-30 to 3-31  
 Heat exchangers, 6-21 to 6-24  
 Heat gun, 3-17  
 Helical spring lockwashers, 6-39  
 High-pressure air compressors, 7-22 to 7-24  
 High-speed pinions, 8-5  
 Hoisting and lifting devices, 3-30 to 3-32  
 chain hoists, 3-30  
 cranes, 3-32  
 hand-operated ratchet lever hoists, 3-30 to 3-31  
 push-pull hydraulic jack, 3-31 to 3-32  
 Hub/blade assembly, 8-31 to 8-34  
 Hydraulic oil power system, 8-36 to 8-41  
 Hydrometer, 3-28 to 3-30  
 Hydrostatic testing, 6-27

## I

Ice detector system, 5-21 to 5-22  
 In-line or cone filter, 6-21  
 Indicating filters, 6-20  
 Indicating instruments, 5-1 to 5-26  
 electrical indicating instruments, 5-19 to 5-21  
 ammeters, 5-19  
 frequency meters, 5-20  
 kilowatt meters, 5-20  
 phase-sequence indicators, 5-21  
 synchrosopes, 5-20 to 5-21  
 voltmeters, 5-19  
 liquid level indicators, 5-17 to 5-18  
 contact level sensors, 5-18  
 tank level indicators, 5-17 to 5-18  
 miscellaneous sensors, 5-21 to 5-25  
 ice detector system, 5-21 to 5-22  
 ice-detector signal conditioners, 5-22  
 ice detectors, 5-21 to 5-22  
 speed sensors, 5-22 to 5-23  
 magnetic speed pickup transducer, 5-22 to 5-23  
 tachometer generators, 5-22  
 ultraviolet flame detector, 5-25  
 flame detector, 5-25  
 flame-detector signal conditioner, 5-25  
 vibration sensors, 5-23 to 5-25

Indicating instruments—Continued  
 pressure measuring instruments, 5-9 to 5-17  
 electrical pressure measuring instruments (transducers), 5-13 to 5-16  
 pressure transducer calibration, 5-13 to 5-16  
 pressure transducer operation, 5-13  
 mechanical pressure measuring instruments, 5-10 to 5-13  
 bellows element, 5-12 to 5-13  
 bourdon-tube elements, 5-10 to 5-12  
 pressure switches, 5-16 to 5-17  
 construction of pressure switches, 5-16  
 setting pressure switches, 5-17  
 temperature measuring instruments, 5-1 to 5-9  
 electrical temperature measuring devices, 5-4 to 5-8  
 resistance temperature detectors, 5-4 to 5-5  
 resistance temperature elements, 5-5 to 5-6  
 thermocouples, 5-6 to 5-8  
 mechanical temperature measuring devices, 5-1 to 5-4  
 bimetallic expansion thermometer, 5-2 to 5-3  
 filled-system thermometers, 5-3 to 5-4  
 liquid-in-glass thermometers, 5-2  
 temperature switches, 5-8 to 5-9  
 adjustments, 5-9  
 construction, 5-8 to 5-9

Inlet filters and strainers, 6-17  
 Input shafts, 8-4  
 Inspection mirror, 3-7  
 Insulation, 6-40 to 6-41

## J

Jam nuts, 6-38  
 Jet pumps, 7-10 to 7-11  
 Journal bearings, 8-6 to 8-7

## K

Kilowatt meters, 5-20  
 Kirchhoff's voltage law, 4-1 to 4-2

## L

Lapping valves, 6-12 to 6-13  
Law of magnetism, 4-2 to 4-3  
Lead-acid storage batteries, 9-23, 10-12 to 10-17  
Leadership, management, and education training school, 1-3 to 1-5  
Levers/leverage, 4-15 to 4-16  
Liquid level indicators, 5-17 to 5-18  
Liquid-in-glass thermometers, 5-2  
List of Navy Electricity and Electronics Training Series, AVI-1  
Locknuts, 6-38 to 6-39  
Lockwashers, 6-39 to 6-40  
Logs and records, 2-5 to 2-9  
    Automatic Bell Log, 2-9  
    Engineering Log, 2-5 to 2-8  
    Engineer's Bell Book, 2-8 to 2-9  
    equipment operating logs, 2-9  
Low-pressure or ship's service air compressors, 7-18 to 7-22  
Low voltage protection, 9-21  
Low voltage release, 9-21  
Lube oil system (DD, DDG, and CG), 8-20 to 8-21, 8-13 to 8-16  
Lube oil system (FFG), 8-16 to 8-17, 8-20 to 8-21  
Lubricating pump, 8-20 to 8-22

## M

Magnetic speed pickup transducer, 5-22 to 5-23  
Main reduction gear (DD, DDG, and CG class ships), 8-1 to 8-30  
Main Space Fire Doctrine, 2-26  
Main thrust bearings, 8-7 to 8-8  
Manual bus transfers (MBTs), 9-18  
Manufacturers' technical manuals, 2-2  
Measurement of temperature, 4-17 to 4-19  
Mechanical energy, 4-11 to 4-13  
Mechanical fingers, 3-6 to 3-7  
Mechanical pressure measuring instruments, 5-10 to 5-13  
Mechanical seals, 7-5  
Mechanical steam traps, 6-13 to 6-14  
Mechanical temperature measuring devices, 5-1 to 5-4  
    bimetallic expansion thermometer, 5-2 to 5-3  
    filled-system thermometers, 5-3 to 5-4  
    liquid-in-glass thermometers, 5-2

Mechanical theory, 4-8 to 4-15  
    energy, 4-11 to 4-15  
    laws and principles, 4-8 to 4-11  
Megohmmeter, 3-27  
Mesh and micron ratings, 6-15 to 6-17  
Metric system, the, AV-1 to AV-4  
Micrometer, 3-13 to 3-16  
Motor controllers, 9-20 to 9-23  
Motors, 9-2 to 9-6  
Motors and generators, 10-5 to 10-9  
MRG instrumentation, 8-24 to 8-25  
Multimeters, 3-26 to 3-27

## N

Naval Sea Systems Command publications, 2-1 to 2-2  
Naval Ship's Technical Manual (NSTM), 2-2  
Newton's laws, 4-9 to 4-10  
Nylon insert nuts, 6-38

## O

O-rings, 6-36 to 6-37  
OD box-mounted potentiometers, 8-43 to 8-44  
Ohm's law, 4-1  
Oil distribution, 8-13 to 8-17  
Oil distribution box, 8-34 to 8-36  
Oil spills, 2-20  
Oily-water separator, 7-36 to 7-38  
Orifice steam traps, 6-14  
Oscilloscopes, 3-27 to 3-28  
Overload relays, 9-22

## P

Packing and gaskets, 6-33  
Pascal's law, 4-10  
Pensky-Martens closed-cup flash point tester, 3-23  
Personnel protection programs, 2-18 to 2-19  
Personnel qualification standards, 2-25 to 2-26  
Phase-sequence indicators, 5-21  
Physical security program, 2-24 to 2-25  
Piping print symbols, AIV-1 to AIV-3  
Piping system components, 6-1 to 6-43  
    fasteners, 6-37 to 6-40  
    locknuts, 6-38 to 6-39  
    jam nuts, 6-38  
    nylon insert nuts, 6-38  
    plastic ring nuts, 6-38  
    spring beam nuts, 6-39  
    spring nuts, 6-38 to 6-39

Piping system components—Continued

- fasteners—Continued
  - lockwashers, 6-39 to 6-40
    - curved or conical spring lockwashers, 6-39
    - helical spring lockwashers, 6-39
    - toothed lockwashers, 6-39 to 6-40
  - threaded locking devices, 6-37
    - length of protrusion, 6-37
    - repair of damaged threads, 6-37
- filters and strainers, 6-15 to 6-21
  - construction of filter elements, 6-18 to 6-19
  - filter/strainer location, 6-17 to 6-18
    - inlet filters and strainers, 6-17
    - pressure line filters, 6-17
    - return line filters, 6-18
  - filter/strainer materials, 6-18
  - filters, types of, 6-19 to 6-21
    - duplex filters, 6-19
    - filter/separator, 6-20 to 6-21
    - full-flow filters, 6-19
    - indicating filters, 6-20
    - in-line or cone filter, 6-21
    - proportional-flow filters, 6-20
    - simplex filter, 6-19
  - maintenance, 6-21
  - mesh and micron ratings, 6-15 to 6-17
- heat exchangers, 6-21 to 6-24
  - classification of heat exchangers, 6-21 to 6-23
    - direction of flow, 6-22 to 6-23
    - number of passes, 6-23
    - path of heat flow, 6-23
    - type of construction, 6-22
    - type of surface, 6-21 to 6-22
  - maintenance of heat exchangers, 6-23
  - zincs, 6-23 to 6-24
- insulation, 6-40 to 6-41
  - general insulation precautions, 6-41
  - insulation materials, 6-40
  - removable insulation, 6-40
- packing and gasket material, 6-33 to 6-37
  - O-rings, 6-36 to 6-37
  - packing of fixed joints, 6-35 to 6-36
  - packing and gasket selection, 6-33 to 6-34
  - packing of moving joints, 6-34 to 6-35
- piping, 6-24 to 6-32
  - fittings, 6-29 to 6-32
    - bolted flange joints, 6-30
    - flared fittings, 6-30 to 6-31
    - flareless fittings, 6-32
    - silver-brazed joints, 6-30

Piping system components—Continued

- piping—Continued
  - fittings—Continued
    - threaded joints, 6-29
    - unions, 6-30
    - welded joints, 6-30
  - flange safety shields, 6-32
  - flexible hose assemblies, 6-24 to 6-29
    - air test, 6-27
    - approved flexible hose configurations, 6-25 to 6-26
    - fitting identification, 6-26
    - hose identification, 6-26
    - hydrostatic test, 6-27
    - inspection of hose and fittings prior to make-up, 6-26
    - installation of flexible hose assemblies, 6-27 to 6-28
    - periodic inspection by ship's force, 6-28
    - service life of rubber hose, 6-29
    - servicing, 6-29
    - shelf life, 6-28 to 6-29
    - storage, 6-28
    - visual inspection, 6-26 to 6-27
  - identification of piping, 6-24
  - inspections and maintenance, 6-32 to 6-33
  - pipe hangers, 6-32
  - piping materials, 6-24
  - piping system identification marking, 6-33
  - steam traps, 6-13 to 6-15
    - maintenance, 6-15
    - types of steam traps, 6-13 to 6-14
      - bimetallic steam traps, 6-14
      - mechanical steam traps, 6-13 to 6-14
      - orifice steam traps, 6-14
  - valves, 6-1 to 6-13
    - maintenance, 6-10 to 6-13
      - grinding-in valves, 6-12
      - lapping valves, 6-12 to 6-13
      - refacing valves, 6-13
      - repacking valves, 6-13
      - spotting-in valves, 6-12
    - valve construction, 6-1
    - valve handwheel identification and color coding, 6-10
    - valve manifolds, 6-9 to 6-10
    - valve types, 6-1 to 6-9
      - check valves, 6-4 to 6-5
      - special-purpose valves, 6-5 to 6-9
      - stop valves, 6-2 to 6-4

- Plastic ring nuts, 6-38
- Polyphase motors, 9-2 to 9-4
- Power circuit analysis, 10-11 to 10-12
- Power distribution components, 9-16 to 9-19
- Power panels and cable markings, 9-19 to 9-20
- Power supply, 3-26
- Power train and controllable pitch propeller, 8-1 to 8-49
  - controllable pitch propeller systems, 8-30 to 8-44
    - control valves manifold block assembly, 8-36
    - electronic pitch control system, 8-41 to 8-44
      - control oil servo valve, 8-42 to 8-43
      - OD box-mounted potentiometers, 8-43 to 8-44
    - hub/blade assembly, 8-31 to 8-34
      - blade seal base ring, 8-32
      - blades, 8-32
      - hub body assembly, 8-31 to 8-32
      - tail-shaft spigot, 8-32 to 8-34
    - hydraulic oil power system, 8-36 to 8-41
      - hydraulic oil power module, 8-38
      - oil distribution, 8-38 to 8-41
      - oil distribution box, 8-34 to 8-36
      - valve rod assembly, 8-34
  - main reduction gear (DD, DDG, and CG class ships), 8-1 to 8-30
    - attached equipment, 8-17 to 8-30
      - controllable reversible pitch hydraulic pump, 8-22
      - dehumidifier, 8-23
      - electrostatic vent fog precipitator, 8-22
      - lubricating pump, 8-20 to 8-22
    - MRG instrumentation, 8-24 to 8-25
    - propeller shaft brakes, 8-28 to 8-30
    - revolution counter and elapsed time indicator, 8-24
    - shaft tachometer, 8-23 to 8-24
    - tachometer generator, revolution counter, and magnetic speed sensor drive, 8-24
    - turbine brakes, 8-26 to 8-28
    - turning gear motor assembly, 8-17 to 8-20
  - bearings, 8-6 to 8-8
    - journal bearings, 8-6 to 8-7
    - main thrust bearings, 8-7 to 8-8
- Power train and controllable pitch propeller—Continued
  - main reduction gear (DD, DDG, and CG class ships)—Continued
    - brake/clutch assembly (DD and DDG class ships), 8-8 to 8-10
      - clutch sequencing, 8-8 to 8-10
      - control air system, 8-8
    - bull gear, 8-6
    - first-reduction gears, 8-5
    - gear casing, 8-4
    - high-speed pinions, 8-5
    - input shafts, 8-4
    - oil distribution, 8-13 to 8-17
      - DD, DDG, AND CG lube oil systems, 8-13 to 8-16
      - FFG lube oil system, 8-16 to 8-17
    - second-reduction pinions, 8-5
    - synchro-self-shifting clutch, 8-11 to 8-13
      - clutch disengagement, 8-12
      - clutch engagement, 8-12
      - lockout control, 8-12 to 8-13
      - lubrication, 8-13
  - prairie air system, 8-44
  - propulsion shafting system, 8-44 to 8-49
    - propulsion shaft seals, 8-45 to 8-49
      - bulkhead seals, 8-45 to 8-47
      - stern tube seals, 8-47 to 8-49
    - shaft bearings, 8-45
      - stern tube bearings, 8-45
      - strut bearings, 8-45
    - shafting, 8-44 to 8-45
- Prairie air system, 8-44
- Precision tools, 3-8 to 3-16
  - micrometer, 3-13 to 3-16
  - simple calipers, 3-11 to 3-12
  - slide calipers, 3-12
  - torque wrenches, 3-8 to 3-11
  - vernier caliper, 3-12 to 3-13
- Pressure definitions, 4-19 to 4-20
- Pressure line filters, 6-17
- Pressure measuring instruments, 5-9 to 5-17
  - electrical pressure measuring instruments (transducers), 5-13 to 5-16
  - mechanical pressure measuring instruments, 5-10 to 5-13
    - pressure switches, 5-16 to 5-17
- Pressure switches, 5-16 to 5-17
- Pressure transducer calibration, 5-13 to 5-16
- Pressure transducer calibration kit, 3-22
- Pressure transducer operation, 5-13
- Propeller shaft brakes, 8-28 to 8-30
- Proportional-flow filters, 6-20

Propulsion shafting, 8-44 to 8-49  
Pumps, 7-1 to 7-13  
Purifiers, 7-13 to 7-17  
Push-pull hydraulic jack, 3-31 to 3-32

## R

Rating information, 1-1 to 1-7  
    advancement requirements, 1-1 to 1-3  
        eligibility requirements for advancement, 1-2  
    exam and notification of results, 1-3  
    professional development, 1-2 to 1-3  
        studying for advancement, 1-2 to 1-3  
        sustained superior performance, 1-2  
    duties and responsibilities, 1-1  
    formation of the GSE/GSM ratings, 1-1  
    training sources, 1-3 to 1-7  
        educational guidance, 1-6 to 1-7  
            command career counselor, 1-7  
            divisional training petty officer, 1-6  
            educational services officer, 1-6 to 1-7  
        schools, 1-3 to 1-5  
            leadership, management, and education training school, 1-3 to 1-5  
            technical schools, 1-3  
        training manuals, 1-5 to 1-6  
Refacing valves, 6-13  
References, AVII-1 to AVII-7  
Refrigeration air dehydrator (type I), 7-25 to 7-26  
Refrigeration and desiccant air dehydrator (type III), 7-27  
Repacking valves, 6-13  
Resistance boxes, 3-25  
Resistance temperature detectors, 5-4 to 5-5  
Resistance temperature elements, 5-5 to 5-6  
Return line filters, 6-18  
Revolution counter and elapsed time indicator, 8-24  
Rotary pumps, 7-8 to 7-10

## S

Safety Program, 2-9 to 2-15  
Salinity indicating system, 7-34  
Schools, 1-3 to 1-5  
Screw and tap extractors, 3-6

Screw pumps, 7-9 to 7-10  
Second-reduction pinions, 8-5  
Shaft bearings, 8-45  
Shaft brakes, 8-28 to 8-30  
Shaft tachometer, 8-23 to 8-24  
Ships' Maintenance and Material Management (3-M) Systems, 2-2 to 2-3  
Shore power, 9-11  
Signal generators, 3-28  
Silver-brazed joints, 6-30  
Simple calipers, 3-11 to 3-12  
Simplex filter, 6-19  
Single-phase motors, 9-4 to 9-6  
60-hertz distribution system components, 9-6 to 9-23  
    motor controllers, 9-20 to 9-23  
    power distribution components, 9-16 to 9-19  
    power panels and cable markings, 9-19 to 9-20  
    switchboards and panels, 9-6 to 9-16  
Slide calipers, 3-12  
Sliding vane pumps, 7-10  
Soot blowers, 7-33 to 7-34  
Special-purpose valves, 6-5 to 6-9  
Specific gravity, 10-12 to 10-13  
Speed sensors, 5-22 to 5-23  
Spotting-in valves, 6-12  
Spring beam nuts, 6-39  
Spring nuts, 6-38 to 6-39  
Standing/night orders, 2-4 to 2-5  
Steam pressure control, 7-32 to 7-33  
Steam separator/water reservoir, 7-30  
Steam traps, 6-13 to 6-15  
Stern tube seals, 8-47 to 8-49  
Stop valves, 6-2 to 6-4  
Stroboscope, 3-17  
Switchboards and panels, 9-6 to 9-16  
Synchro-self-shifting clutch, 8-11 to 8-13  
Synchrosopes, 5-20 to 5-21

## T

Tachometer generator, revolution counter, and magnetic speed sensor drive, 8-24  
Tank level indicators, 5-17 to 5-18  
Taps and dies, 3-4 to 3-5  
Technical schools, 1-3

Temperature measuring instruments, 5-1 to 5-9

- electrical temperature measuring devices, 5-4 to 5-8
- mechanical temperature measuring devices, 5-1 to 5-4
- temperature switches, 5-8 to 5-9

Temperature switches, 5-8 to 5-9

Test equipment, 3-16 to 3-30

Thermal energy, 4-13 to 4-14

Thermocouples, 5-6 to 5-8

Thread chasers, 3-5 to 3-6

Threaded joints, 6-29

Threaded locking devices, 6-37

Tools and test equipment, 3-1 to 3-32

- hand tools, 3-1 to 3-8
  - inspection mirror, 3-7
  - mechanical fingers, 3-6 to 3-7
  - screw and tap extractors, 3-6
  - taps and dies, 3-4 to 3-5
  - thread chasers, 3-5 to 3-6
  - wire-twister pliers, 3-1 to 3-3
  - wire-wrap hand tools, 3-8
  - wrenches, 3-3 to 3-4
    - nonrecommended wrenches and hand tools, 3-4
    - recommended wrenches, 3-3 to 3-4
- hoisting and lifting devices, 3-30 to 3-32
  - chain hoists, 3-30
  - cranes, 3-32
  - hand-operated ratchet lever hoists, 3-30 to 3-31
  - push-pull hydraulic jack, 3-31 to 3-32
- precision tools, 3-8 to 3-16
  - micrometer, 3-13 to 3-16
    - reading a micrometer caliper, 3-14 to 3-16
    - reading a vernier micrometer caliper, 3-16
    - selecting the proper micrometer, 3-14
    - types of micrometers, 3-13 to 3-14
  - simple calipers, 3-11 to 3-12
  - slide calipers, 3-12
  - torque wrenches, 3-8 to 3-11
    - proper use of torque wrenches, 3-10 to 3-11
    - torque valves, 3-9 to 3-10
    - types of torque wrenches, 3-9
  - vernier caliper, 3-12 to 3-13

Tools and test equipment-Continued

test equipment, 3-16 to 3-30

- A.E.L. contaminated fuel detector MK III, 3-25
- A.E.L. free water detector MK II, 3-24 to 3-25
- borescope, 3-17 to 3-20
  - borescope use, 3-18 to 3-20
  - function of the borescope, 3-17 to 3-18
- centrifuge, 3-22 to 3-23
- deadweight tester/gauge comparator, 3-16 to 3-17
- electronic digital multimeters, 3-27
- frequency counters, 3-28
- heat gun, 3-17
- hydrometer, 3-28 to 3-30
- megohmmeter, 3-27
- multimeters, 3-26 to 3-27
- oscilloscopes, 3-27 to 3-28
- Pensky-Martens closed-cup flash point tester, 3-23
- power supply, 3-26
- pressure transducer calibration kit, 3-22
- resistance boxes, 3-25
- signal generators, 3-28
- stroboscope, 3-17
- ultraviolet test unit, 3-17
- vibration analysis, 3-20 to 3-22
  - vibration analyzers, 3-21 to 3-22
  - vibration meter, 3-21

Toothed lockwashers, 6-39 to 6-40

Torque wrenches, 3-8 to 3-11

Training sources, 1-3 to 1-7

- educational guidance, 1-6 to 1-7
- schools, 1-3 to 1-5
- training manuals, 1-5 to 1-6

Transformers, 9-18 to 9-19

Tubular-type purifier, 7-16 to 7-17

Turbine brakes, 8-26 to 8-28

Turning gear motor assembly, 8-17 to 8-20

## U

Ultraviolet flame detector, 5-25

Ultraviolet test unit, 3-17

Uninterruptible power supply, 9-23  
Unions, 6-30

Vibration sensors, 5-23 to 5-25  
Voltmeters, 5-19

## V

Valve maintenance, 2-25  
Valve rod assembly, 8-34  
Valves, 6-1 to 6-13  
    maintenance, 6-10 to 6-13  
    valve construction, 6-1  
    valve handwheel identification and color coding, 6-10  
    valve manifolds, 6-9 to 6-10  
    valve types, 6-1 to 6-9  
Vernier caliper, 3-12 to 3-13  
Vibration analysis, 3-20 to 3-22

## W

Waste-heat boiler, 7-27 to 7-36  
Waste heat boiler treatment, 2-24  
Welded joints, 6-30  
Wire wrapping, 10-1 to 10-5  
Wire-twister pliers, 3-1 to 3-3  
Wire-wrap hand tools, 3-8  
Wrenches, 3-3 to 3-4

## Z

Zincs, 6-23 to 6-24



