

g j z r % l " § k r s + & ? g d z i q r w k p o r c

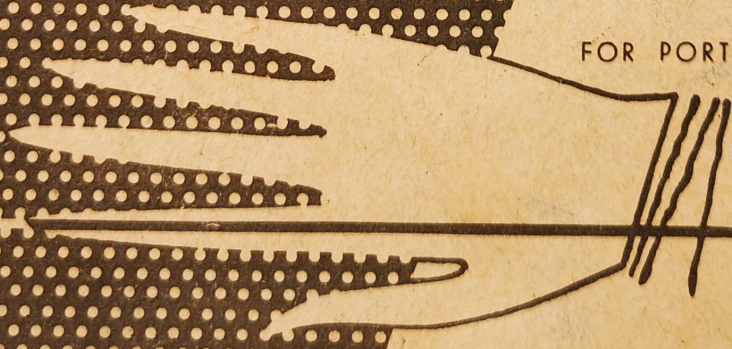

# Operating instruction

FOR PORTABLE TRAVEL TYPEWRITER



A B

OPERATING INSTRUCTIONS  
FOR PORTABLE TRAVEL TYPEWRITER, MODEL 1531

We wish to enclose this manual to acquaint you as a new owner of the portable travel typewriter, Model 1531, with its operation and maintenance.

Though the operation of the portable travel typewriter is very simple, we recommend you to devote a few minutes to the study of these instructions as the thorough acquaintance with the machine will enable you to take full advantage of the machine and ensure your long-lasting satisfaction.

At the same time we wish to inform you briefly of some advantages of this typewriter. The portable travel typewriter is simple but very efficient. It is well constructed, has a modern shape and perfectly finished surface. All its details are of tasteful and practical design. Its size and weight are therefore minimal, well above the world standard.

Letters which are easy to read, light, uniform touch, easy operation, long service life are the advantages of the portable travel typewriter which will make you fully satisfied.

We trust that you will appreciate not only these merits the character of which is explicitly technical but also the elegant and tasteful appearance of the practical carrying case made of plastics.

You may rest assured that your new portable travel typewriter, Model 1531, will fulfil your hopes in all respects and be your indispensable and inseparable aid.

C o n t e n t s :

	Page
Specification of portable travel typewriter .....	5
Technical data .....	6
Preparing the typewriter for typing .....	7
Inserting and adjusting paper .....	7
Adjusting the left and right margins .....	7
Line space adjusting .....	7
Using the paper bottom edge marker .....	8
Adjusting the line .....	9
Using the line gauge for lining .....	9
Carriage back spacing .....	10
Typing of capital letters .....	10
Typing beyond the adjusted margin stops .....	10
Lifting and replacing the top cover .....	10
Ribbon motion reversing .....	11
Ribbon change .....	11
Preparing the typewriter for inserting into the case .....	12
Cleaning and maintenance of the typewriter .....	12

1. Manually adjustable margin stops
2. Platen
3. Paper bail
4. Auxiliary paper rest button
5. Paper erasing table
6. Paper rest
7. Paper bail release lever
8. Carriage escapement lever
9. Ribbon guide
10. Ribbon spool (Under the top cover)
11. Ribbon braking spring (Under the top cover)
12. Ribbon reverse actuating arm (Partially under the top cover)
13. Top cover
14. Back spacer key
15. Margin release key
16. Keytop of shift key lever
17. Line spacer
18. Shift lock key
19. Line spacer lever
20. Line gauge
21. Line spacer release (Platen clutch knob)
22. Line spacer
23. Paper bottom edge marker

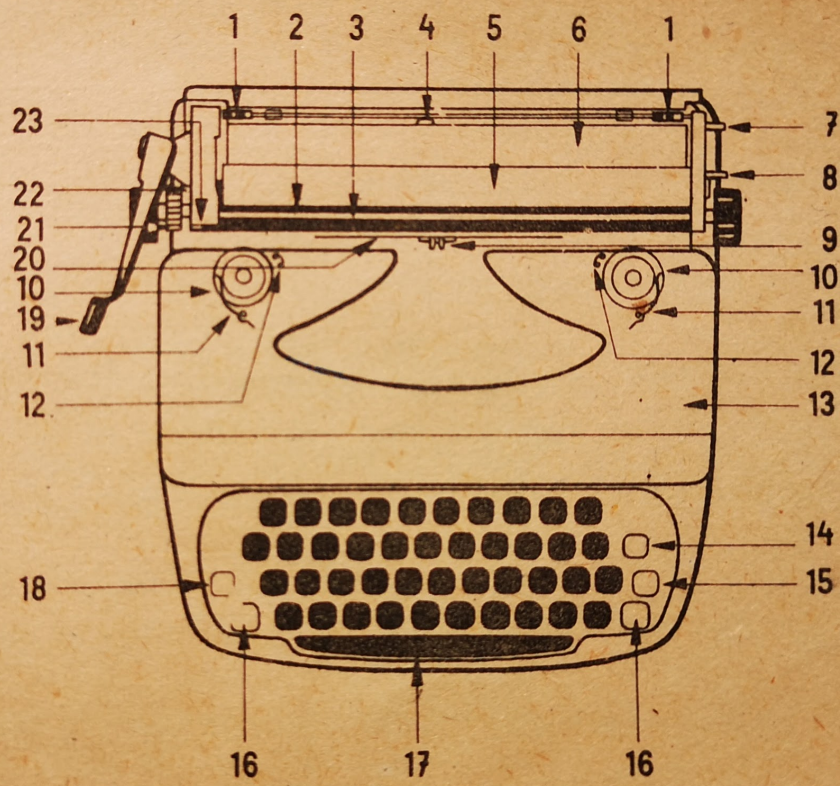

Technical data:

Number of keys	42
Platen length	240 mm
Platen diameter	32.5 mm
Typewriter size (with case)	310x315x75 mm
Letter types	Pica, size 2.6 mm
Shift	6.7 mm
Ribbon	one-coloured, width 13 mm, automatic rewinding
Typewriter weight (with case)	about 4.5 kg
Typewriter weight (without case)	3.4 kg

the left so far until the line spacer lever is off the top cover (13). Then pull the top cover upwards, and after overcoming the force of springs, the cover is removed.

When replacing the cover, put it into its original position and press it downwards. The spring retainer will latch and secure the cover against falling out.

#### Ribbon motion reversing

The ribbon should pass between the pins of ribbon reverse actuating arms (12). Then the ribbon winds automatically from one spool to the other, and back again. In the case of need, e.g. when changing the ribbon, the motion of the ribbon can also be reversed manually. By setting the left ribbon reverse actuating arm (12) towards the operator, the direction of ribbon winding is set from the right to the left spool; by setting the right ribbon reverse actuating arm (12) towards the operator, the direction is set from the left to the right spool. If the top cover is on there projects from it the ribbon reverse actuating arm of the spool from which the ribbon is being wound off.

#### Ribbon change

When changing the used-up ribbon, follow the following instructions:  
Remove the top cover of the typewriter, slip off the ribbon from the ribbon guide (9), deflect the ribbon braking spring (11) and take out the spools with the ribbon from the typewriter. Suspend the loose end of the new ribbon on the hook of the empty spool. Then deflect the ribbon braking springs and put both spools on the spool shafts so that the ribbon is wound on the left spool by turning to the left, and on the right one by turning to the right. Then suspend the new ribbon on the ribbon guide and slip it through the guiding pins of both ribbon reverse actuating arms.



### Carriage back spacing

By pressing the back spacer key (←) (14), the carriage is shifted one type back. For shifting the carriage to the left, use the carriage escapement lever (8).

### Typing of capital letters

By pressing one shift key lever keytop (16), the carriage is lifted into its upper position and capital letters and upper marks can be typed. For continuous typing of capital letters secure the shift key in its lower position by pressing the shift lock key (18). The shift lock key is placed on the left end of the second row of keys and marked with (Ⓛ) .

The shift lock can be released by pressing the keytop of the left shift key lever.

### Typing beyond the adjusted margin stops

The margin bell will ring seven types before the adjusted end of the line is reached. If you wish to proceed further with the automatic keyboard locked, depress the margin release key (⊕) (15); the keyboard will be released and typing can continue until the end of the platen is reached.

If there is a need of typing in front of the adjusted left margin, depress the margin release key (⊕) (15) and shift the carriage into the desired position.

### Lifting and replacing the top cover

It is necessary to change the ribbon and clean the types often and periodically. To do this, the top cover must be removed in the following way: shift the carriage to

The above-described system is valid for a paper sheet 28 cm long. For paper size A4 which is 30 cm long turn the cylinder before inserting the paper to number 30. For half-size paper, i.e. size A5 which is 15 cm long, turn the cylinder before placing the paper on number 15.

Whatever the size stop typing as soon as number 28 appears under the marker!

#### Adjusting the line

If there is a need for re-inserting the typed paper into the machine, e.g. when correcting mistakes, follow the following instructions:

Horizontal adjusting: Release the paper by paper bail release lever (7) and shift the paper until the centres of the types (type m in particular) are against the lines on the line gauge (20) and the bottom edge of the line is parallel to the line gauge.

Vertical adjusting: Disengage line spacing by turning the platen clutch knob (21) backwards. Then by turning the platen shift the bottom edge of the line close above the line gauge.

#### Using the line gauge for lining

The line gauge (20) can also be used as an aid for lining forms.

Horizontal lining is carried out in the following way: insert the pencil point into the hole of line gauge, press the carriage escapement lever (3) and line by moving the carriage.

Vertical lining: disengage line spacing by platen clutch knob (21) and line by turning the cylinder.

### Preparing the typewriter for typing

After taking out the typewriter from the case, lift the line spacer lever (19) into its upper position. Then press the small chromium-plated projecting piece of the auxiliary paper rest (4) placed in the centre behind the paper rest. This will raise automatically the auxiliary paper rest.

### Inserting and adjusting paper

Insert the sheet of paper behind the platen (2) on the paper rest so that its bottom edge reaches the hold down rolls. By turning the platen shift the paper into the desired position.

The paper should pass under the paper bail (3) and above the paper erasing table (5).

Should it be required to adjust the paper, release it by deflecting the paper bail release lever (7) forwards and adjust it. After replacing the paper bail release lever (7) to its normal position, the paper is held by the platen again.

### Adjusting the left and right margins

This is carried out by manually adjustable margin stops (1) placed behind the paper rest.

By pressing the button, release the left margin stop and shift it to the position of the desired beginning of the line.

### Line space adjusting

The line spacer (22) is placed on the left side of the carriage. On its top there is

a red line which on the scale placed on the left arm of the paper bail (3) indicates the line space adjusted by the line spacer. The line spacer can be adjusted to 1 (4.25 mm), 1 1/2 (6.4 mm) or 2 (8.5 mm) normal lines.

If you wish to type without using line spacing (e.g. when filling-in forms), hold the right knob of the platen and by turning the platen clutch knob (21) backwards disengage the line spacing. Now, the platen can be turned by hand to the required position.

Should it be required to use line spacing again, the platen clutch knob must be tightened by turning it forwards.

#### Using the paper bottom edge marker

The paper bottom edge marker (23) is placed on the left side of the cylinder. It indicates the distance of the line just typed from the bottom edge of the paper, so that the paper is not allowed to fall out from the typewriter. By using it, the customary checking of the distance by backwinding the paper is not necessary.

When proceeding in this way, follow these instructions:

The paper bottom edge marker is adjusted until the distance of the last typed line to the bottom edge is 2 cm. Therefore turn the platen until number 28 on the red-white ring is under the bottom edge of the marker. Then insert the 28 cm long sheet of paper behind the platen so that it reaches the hold down rolls. By turning the platen the paper is shifted to the first line and typing can begin. When approaching the bottom edge of the paper, mind the ring. The length of the red strip on the ring under the marker indicates the distance of the line from the bottom edge of the paper. When number 28 appears under the marker, the line just typed is at a distance of two cm from the bottom edge of the paper.

The machine is adapted to standard ribbon spools. If the new spool cannot be put on the spool shaft so easily as the original one, it is not of standard size. In this case use the original ribbon spool, unwind the used-up ribbon and wind on it the new ribbon.

#### Preparing the typewriter for inserting into the case

Bend the auxiliary paper rest (4) to the right so that it latches the retainer. Shift the carriage to the left, and press the line spacer lever to the right and then into its lower position. The line spacer lever is held in this position by a spring retainer. Then shift the carriage to the right until the line spacer lever is against the cover of the typewriter. Now typewriter can be inserted into the case.

#### Cleaning and maintenance of the typewriter

The portable travel typewriter is simple, efficient, well-constructed and of good workmanship. To ensure its long-lasting high efficiency, it is sufficient to protect it against its main enemies: dust, dirt and rubber waste.

By careless erasing, the rubber waste falls into the typewriter (mainly into the slots of the type bar lever segment) and damages its mechanism. This may cause defects and premature wear.

When erasing, follow these instructions:

Bend the paper bail (3) into its upper position and shift the cylinder until the place of erasing is on the paper erasing table (5). Shift the carriage to the left or to the right so that the rubber waste falls outside the typewriter.

Clean the types with a brush or a plastic rubber. When cleaning, put a cloth or a

sheet of paper under the types so that the dirt does not fall from the types into the typewriter.

Clean the cylinder and the lacquered parts of the typewriter with a dry cloth. Remove the dust and impurities from the other surface parts with a brush.

#### Lubricating

Lubricate only the prismatic grooves on which the carriage moves, the line spacer lever and cylinder bearings with a few drops of oil.

We recommend to have the typewriter periodically maintained by an expert.

Remember the guarantee - do not repair any accidental defect by yourselves, use our expert service!

If the instructions contained in this manual are followed you can be sure to be fully satisfied with the new portable travel typewriter, Model 1531.

It will fulfil all your hopes and become your inseparable and indispensable aid.



**OPERATION  
AND MAINTENANCE MANUAL**

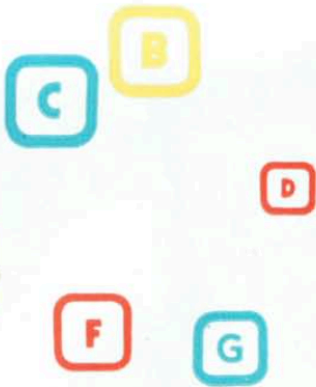

**FOR PORTABLE TYPEWRITER**

**PRINTED IN CZECHOSLOVAKIA**



*Although the operation of the portable typewriter is very simple, we do recommend that you study these instructions so that you can take full advantage of all that the machine can do and be able to have it in good condition for many years to come.*

*It is both simple and efficient, practical yet beautiful. Its size and weight are less than any other such machine. It has both a light touch and a uniform legibility to equal that of the normal „standard” machine.*

*This portable typewriter will be your faithful companion — now learn all you can about it and you will be well repaid.*



## CONTENTS

	Page
Specification of portable typewriter . . . . .	6
Technical data . . . . .	6
Preparing the typewriter for typing . . . . .	7
Inserting and adjusting paper . . . . .	8
Adjusting the left and right margins . . . . .	9
Line space adjusting . . . . .	10
The paper bottom edge marker . . . . .	11
Adjusting the line . . . . .	12
Using the line gauge for drawing lines . . . . .	13
Carriage back spacing . . . . .	14
Typing of capital letters . . . . .	14
Typing beyond the adjusted margin stops . . . . .	14
Lifting and replacing the top cover . . . . .	15
Ribbon motion reversing . . . . .	16
Ribbon change . . . . .	16
Preparing the typewriter for insertion into the case . . . . .	17
Cleaning and maintenance of the typewriter . . . . .	18



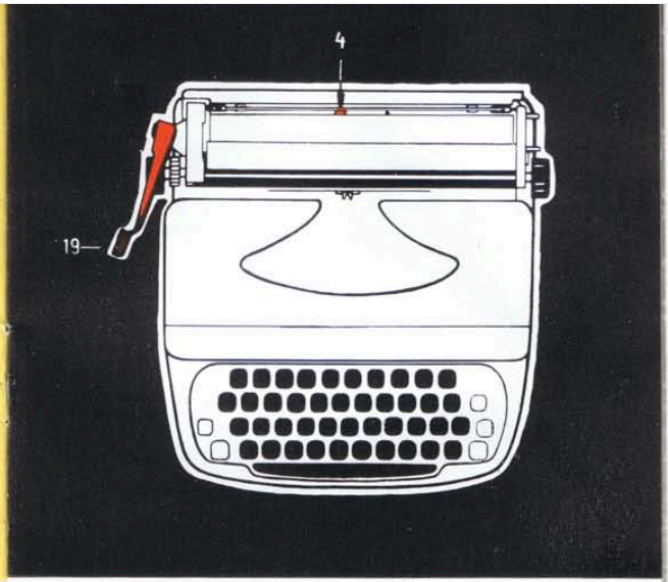
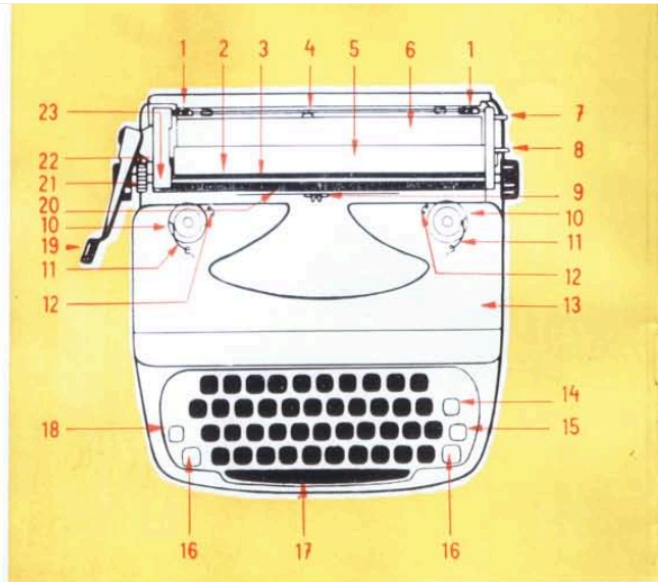

- |   |  |
|---|--|
| 1. Margin stops                                 | 12. Ribbon reverse lever (partially under the top cover) |
| 2. Platen                                       | 13. Top cover  |
| 3. Paper bar                                    | 14. Back spacer key                                      |
| 4. Auxiliary paper rest button                  | 15. Margin release key                                   |
| 5. Paper erasing table                          | 16. Shift key  |
| 6. Paper rest                                   | 17. Line spacer  |
| 7. Paper feed release lever                     | 18. Shift lock   |
| 8. Carriage escapement lever                    | 19. Line space lever                                     |
| 9. Ribbon guide                                 | 20. Line gauge   |
| 10. Ribbon spool (under the top cover)          | 21. Platen release lever                                 |
| 11. Ribbon braking spring (under the top cover) | 22. Line spacer  |
|   | 23. Paper bottom edge marker                             |

**PREPARING THE TYPEWRITER FOR TYPING**

After taking out the typewriter from the case, lift the line space lever (19) into its upper position. Press the small chromium-plated projecting button of the auxiliary paper rest (4) placed in the centre behind the paper rest which will raise the auxiliary paper rest.

**TECHNICAL DATA**

Number of keys	42	
Platen length	240 mm	9 1/2"
Platen diameter	32,5 mm	1,275"
Typewriter size (with case)	310 x 315 x 75 mm	12" x 12 1/2" x 3"
Letter types	PICA, size 2.6 mm	
	ELITE, size 2.08 mm	
Shift	6.7 mm	
Ribbon	one-coloured, width 13 mm automatic rewinding	0.511"
Typewriter weight (with case)	about 4.5 kg	10 lbs.
Typewriter weight (without case)	3.4 kg	7 1/2 lbs.

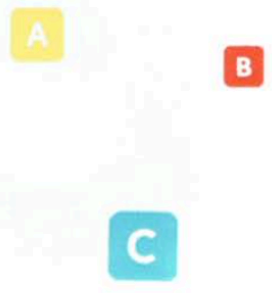

Screenshot

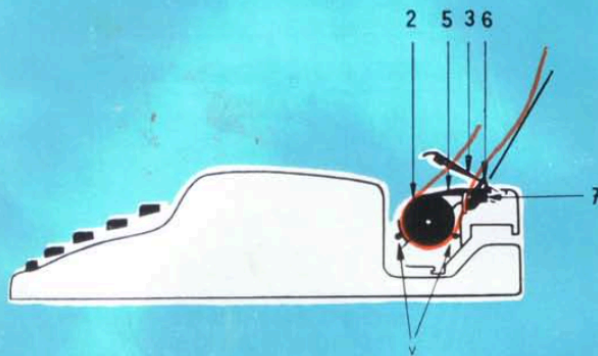

### INSERTING AND ADJUSTING PAPER

Insert the sheet of paper behind the platen (2) on the paper rest (6) so that its bottom edge reaches the hold down rollers (V). By turning the platen shift the paper into the desired position.

The paper should pass under the paper bar (3) and above the paper erasing table (5).

Should it be required to adjust the paper, release it by deflecting the paper feed release lever (7) forwards and adjust it. After replacing the paper feed release lever (7) to its normal position, the paper is held by the platen again.

### ADJUSTING THE LEFT AND RIGHT MARGINS

This is carried out by manually adjustable margin stops (1) placed behind the paper rest. When the button is pressed, the left margin stop is released and can be shifted to the desired position for the beginning of the line. This is also applicable to the right hand margin stop.

A

B

C

C

B

A

Screenshot

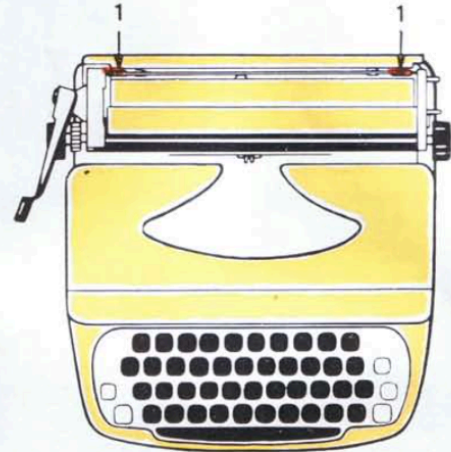
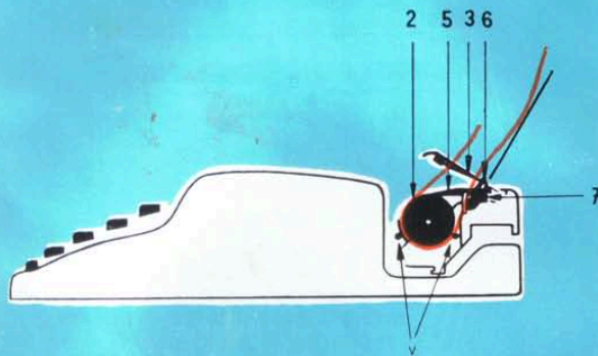

### INSERTING AND ADJUSTING PAPER

Insert the sheet of paper behind the platen (2) on the paper rest (6) so that its bottom edge reaches the hold down rollers (V). By turning the platen shift the paper into the desired position.

The paper should pass under the paper bar (3) and above the paper erasing table (5).

Should it be required to adjust the paper, release it by deflecting the paper feed release lever (7) forwards and adjust it. After replacing the paper feed release lever (7) to its normal position, the paper is held by the platen again.

### ADJUSTING THE LEFT AND RIGHT MARGINS

This is carried out by manually adjustable margin stops (1) placed behind the paper rest. When the button is pressed, the left margin stop is released and can be shifted to the desired position for the beginning of the line. This is also applicable to the right hand margin stop.

A

B

C

C

B

A

Screenshot

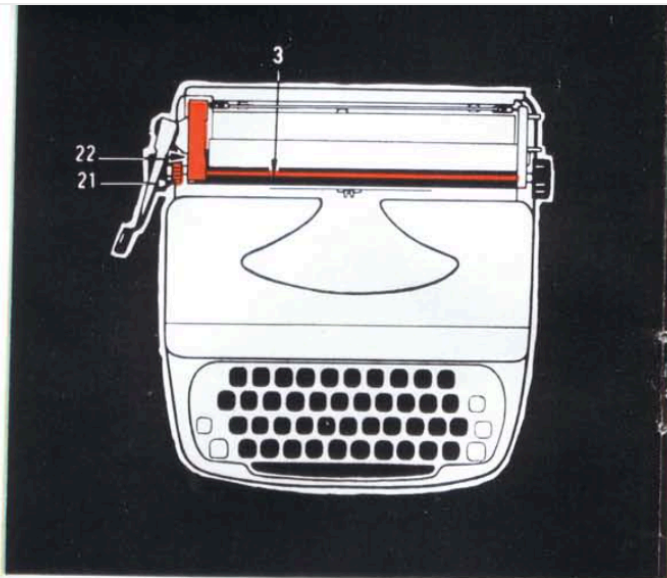

### LINE SPACE ADJUSTING

The line spacer (22) is placed on the left side of the carriage. On its top there is a red line which on the scale placed on the left arm of the paper bar (3) indicates the line space adjusted by the line spacer. The line spacer can be adjusted to 1, 1½ or 2 normal lines.

If you wish to type without using line spacing (e. g. when filling-in forms), hold the right knob of the platen and by turning the platen release lever (21) backwards disengage the line spacing. Now, the platen can be turned by hand to the required position.

Should it be required to use line spacing again, the platen release lever must be tightened by turning it forwards.

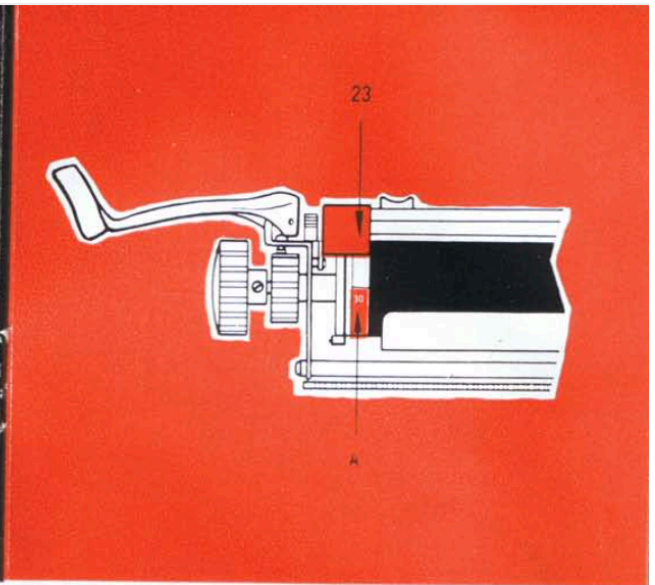

### THE PAPER BOTTOM EDGE MARKER

The paper bottom edge marker (23) is placed on the left side of the platen. It indicates the distance of the line just typed from the bottom edge of the paper, so that the paper is not allowed to fall out from the typewriter. By using it, the customary checking of the distance by backwinding the paper is not necessary.

The paper bottom edge marker is adjusted until the distance from the last typed line to the bottom edge is 2 cm. Turn the platen until number 28 on the red-white ring (A) is under the bottom edge of the marker. Insert the regular sheet of paper behind the platen so that it reaches the hold down rollers. By turning the platen the paper is shifted to the first line and typing can begin. When approaching the bottom edge of the paper watch out for the ring. The length of the red strip on the ring under the marker indicates the distance of the line from the bottom edge of the paper. When number 28 appears under the marker, the line just typed is at a distance of approx. 1 inch from the bottom edge of the paper.

Whatever the size stop typing as soon as number 28 appears under the marker!



Screenshot

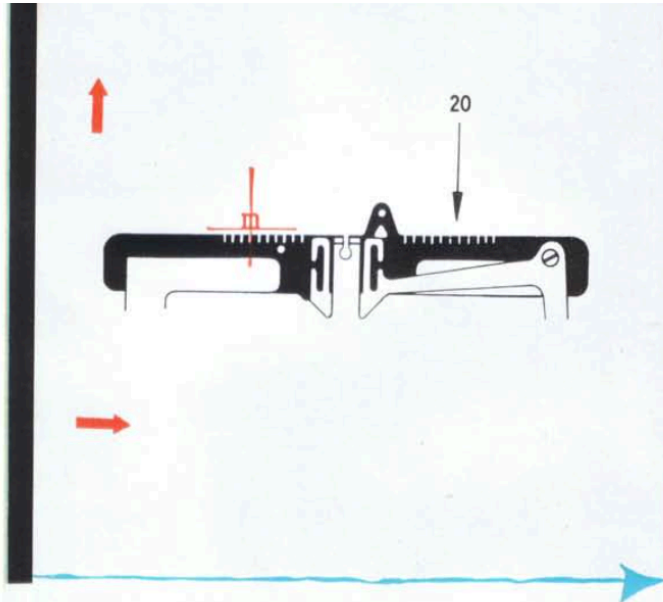

### ADJUSTING THE LINE

If there is a need for re-inserting the typed paper into the machine, e. g. when correcting mistakes etc., the following information will be useful in order to place the paper in position:

*Horizontal adjusting:* Release the paper by paper bar release lever (7) and shift the paper until the centres of the types (type **m** in particular) are against the lines on the line gauge (20) and the bottom edge of the line is parallel to the line gauge.

*Vertical adjusting:* Disengage line spacing by turning the platen release lever (21) backwards. Then by turning the platen shift the bottom edge of the line close above the line gauge.

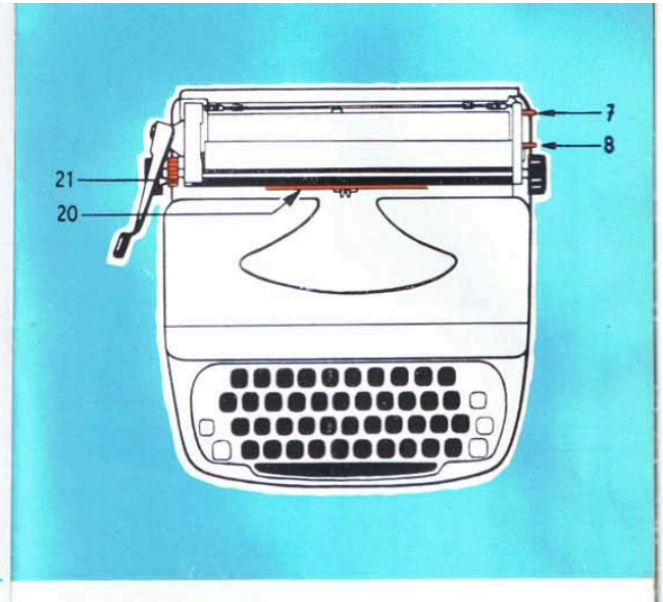

### USING THE LINE GAUGE (20) FOR DRAWING LINES

Horizontal lining is carried out by inserting the pencil point into the hole of the line gauge, pressing the carriage escapement lever (8) and moving the carriage.

Vertical lining: Release the platen (21) and line by turning the platen.

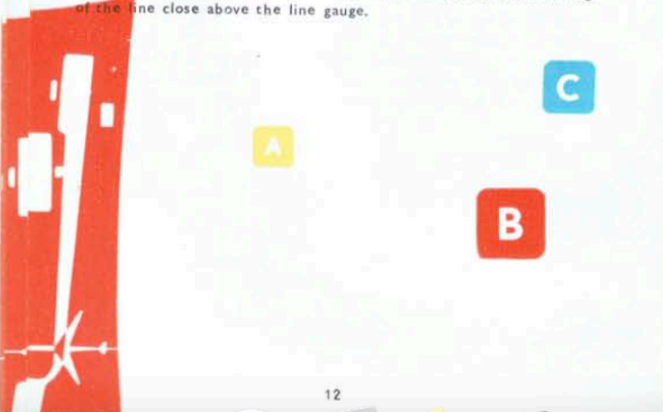

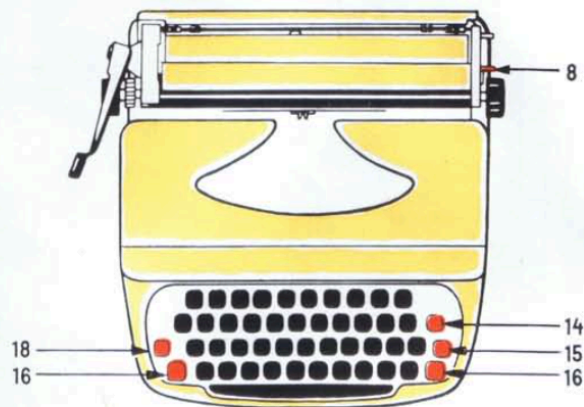



### CARRIAGE BACK SPACING

By pressing the back spacer key  (14), the carriage is shifted one space back. For shifting the carriage to the left, use the carriage escape lever (8).

### TYPING OF CAPITAL LETTERS

Press the shift key (16) for single capital letters. When requiring continuous typing of capital letters, secure the shift lock  (18) (this is released by pressing the shift key (16)).

### TYPING BEYOND THE ADJUSTED MARGIN STOPS

The margin bell will ring seven spaces before the adjusted end of the line is reached. If you wish to type further without adjusting your right-hand margin, depress the margin release key  (15). The margin release key  (15) is also used when it is necessary to type in front of the adjusted left-hand margin.



### LIFTING AND REPLACING THE TOP COVER

It is necessary to remove the top cover frequently in order to change the ribbon and clean the type faces. Shift the carriage to the left until the line space lever is away from the top cover (13). Pull the cover upwards and after overcoming the force of spring, the cover is removed. When replacing the cover, put it into its original position and press it downwards. The spring retainer will latch and secure the cover against falling out.

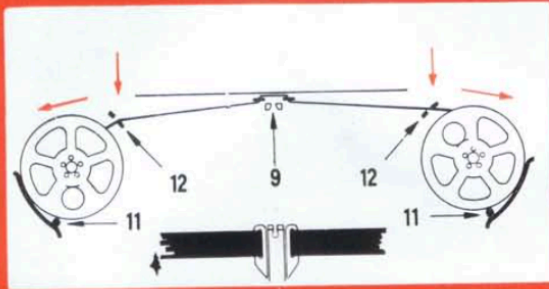

### RIBBON MOTION REVERSING

The ribbon should pass between the pins of ribbon reverse lever (12). Then the ribbon winds automatically from one spool to the other, and back again. In the case of need, e. g. when changing the ribbon, the motion of the ribbon can also be reversed manually. By setting the left ribbon reverse lever (12) towards the operator, the direction of ribbon winding is set from the right to the left spool; by setting the right ribbon reverse lever (12) towards the operator, the direction is set from the left to the right spool. If the top cover is on there projects from it the ribbon reverse lever of the spool from which the ribbon is being wound off.

### RIBBON CHANGE

When changing the used-up ribbon, follow the following instructions: Remove the top cover of the typewriter, slip off the ribbon from the ribbon guide (9), deflect the ribbon braking spring (11) and take out the spools with the ribbon from the typewriter. Suspend the loose end of the new ribbon on the hook of the empty spool. Then deflect the ribbon braking springs and put both spools on the spool shafts so that the ribbon is wound on the left spool by turning to the left, and on the right one by turning to the right. Then suspend the new ribbon on the ribbon guide and slip it through the guiding pins of both ribbon reverse levers.

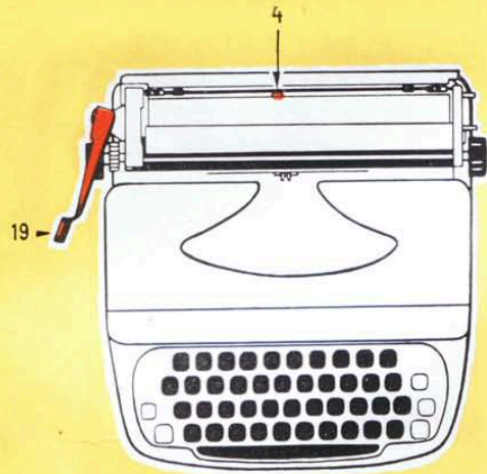

### PREPARING THE TYPEWRITER FOR INSERTION INTO THE CASE

Depress the auxiliary paper rest (4) to the right until it stays without holding. Shift the carriage to the left, and press the line space lever (19) to the right and then into its lower position. The line space lever is held in this position by a spring retainer. Then shift the carriage to the right until the line space lever is against the cover of the typewriter. The typewriter is now ready for insertion into the case.

Screenshot

C

A

C

B

17



### CLEANING AND MAINTENANCE OF THE TYPEWRITER

The portable typewriter is simple, efficient, well-constructed, and of good workmanship. To ensure its long-lasting high efficiency, it is necessary to protect it against its main enemies: dust, dirt and rubber waste.

By careless erasing, the rubber waste falls into the typewriter (mainly into the slots of the type bar lever segment) and damages its mechanism. This may cause defects and premature wear.

Therefore, when erasing, lift the paper bar (3) into its upper position and shift the platen until the place of erasing is on the paper erasing table (5). Shift the carriage to the left or to the right so that the rubber waste falls outside the typewriter.

Clean the type faces with a brush or a plastic rubber. When cleaning, put a cloth or a sheet of paper under the type faces so that the dirt does not fall from the type faces into the typewriter.

Clean the rubber rollers and the lacquered parts of the typewriter with a dry cloth. Remove the dust and impurities from the other surface parts with a brush.

### LUBRICATING

Lubricate only the prismatic grooves on which the carriage moves, the line space lever, the platen Screenshot few drops of oil.

We recommend that the typewriter is serviced periodically by an expert. Remember the guarantee — do not repair any defect yourselves but

C  
B  
A



If the instructions contained in this manual are followed you will be completely satisfied with this new portable typewriter.