

# Conowingo Models



## 24 and 36-Foot Flatcar/ Logging Car / Gondola

HO Scale



[www.conowingomodels.com](http://www.conowingomodels.com)  
<https://www.facebook.com/ConowingoModels/>  
[conowingomodels@yahoo.com](mailto:conowingomodels@yahoo.com)

Dec 2021 Revision



**Thank you for purchasing this kit!**

The enclosed flatcar is fictional but based on some real-world information.

Supplied are the basic directions. For more tips and some additional instructions, please see [conowingomodels.com](http://conowingomodels.com)

### **BUILDING**

1. Start out by removing the frame from its carrier. Note there is a side with lines that denote where the bolsters and queen posts go. This is the underside. You'll also note where the coupler boxes go. Plan out where you'll want to add weights. The NMRA, in RP-20 (essentially) states that the 24-footer should weigh 2.75 ounces when completed and the 36-footer should weigh 3.875 ounces. An unweighted example I used weighed less than .5 ounces. If you're not liking the options, We'd suggest adding a permanent load weight. Failure to add weight will result in a very uncooperative car that doesn't stay on the tracks. We recently found **tungsten putty**. It's

available from Amazon, but can probably be found elsewhere. It works well on the rolling stock. Once you've applied the decking, bolsters and queen post(s), fill in the gaps on the main body with tungsten putty.

2. Assemble the trucks and coupler boxes (some kits) as shown below.

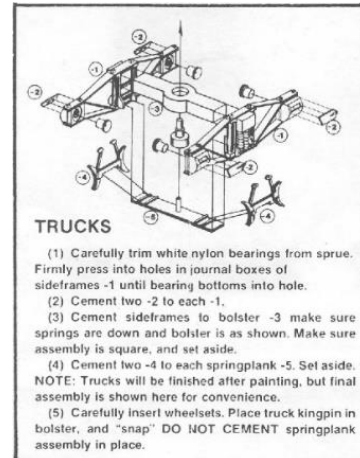

(Courtesy Tichy Train Group)

3. Paint the NBWs, stake pockets, ladders, brake parts and trucks as desired. See step 19 for illustration.
4. We recommend that if you are planning on staining the car, you stain the frame now. Add a lot of weight to flatten it and let it sit for 24 hours before continuing any step that utilizes the frame.
5. Take the included needle and run it through the holes in the end and side pieces as well as the truss rod holes to ensure that there is no glue or errant laser residue in them.
6. Now is a good time to cut the stripwood for the decking to 9.5 scale feet wide or 1 5/16 inches. Scrape the pieces with a hobby knife, scuff them with a sanding block, cut the edges off of and add nail holes as you feel appropriate. I've found that painting/staining at this time is not a good idea because you'll trim the edges later.
7. Carefully cut the angled bolster pieces out and glue them together in pairs. You will end up with four pairs. Run the needle through the holes in the bolsters again to ensure they are properly aligned.



You can do the same with the smaller square bolster pieces, using one thick and one thin piece for each. You will end up with two pieces.

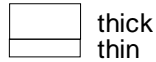

- Glue the side rails into place before the end pieces. Ensure the side rails either fit snugly against the decking or under it, depending on your decision for overhang or not. The end pieces should fit snugly against the side rails and the cut out on each end should match up to allow for the coupler box to fit.



- With the top side is up, glue down the stripwood as shown. I covered both end pieces and side rails. Ensure you leave a small gap between the pieces to prevent buckling when you paint/stain it. IMHO it looks better with spaces as well. A few not-so-perfectly-aligned pieces add life to it.
- When finished adding the decking, Flip the bottom side up and flatten with a heavy object to prevent warping during the drying process. Be sure not to crush the side or end pieces. You may want to consider clamping the corners to something solid instead.
- Once dry, glue the bolsters and queen post(s) into place and secure with clamps. The side pieces of the bolsters are notched to fit the under decking of the car. Ensure you use one of each thickness on the bolster center pieces.

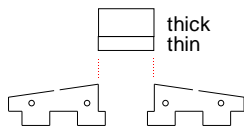

The 24-footer gets the single, wooden queen post while the 36-footer has the option of two wooden posts or two flat basswood pieces with plastic posts.

- Included is the standard Westinghouse K-brake system. I'm not that familiar with the system. If you are, please enlighten us on the Facebook page. Glue the brake reservoir (4), brake cylinder (3) and any

other desired details into place on the underside. There are notches where they need to go.

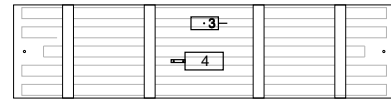

(36-foot car shown)

- Run the included needle through the holes in the bolsters to ensure a clear pathway. The laser and glue can clog those when you least want it to.
- Take the length of thread and put an overhand knot in one end (I used three and a dab of CA at the first bolster because the thread is thin) and gently thread it through the bolsters and queen posts as shown below. The wooden queen posts have notches for the truss rods to pass over. Initially, concentrate on just getting it threaded and then tighten it.

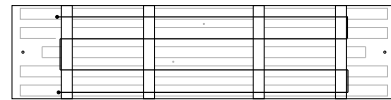

(36-foot car shown)

- Once taut, apply a drop of CA to the thread at the end of the threading to hold it in place. I hung the whole assembly from my workbench with a small clamp while it dries to keep tension on it. When it's dry, add the final knot (or several) as close to the bolster as you can get it and cut the excess. A drop of glue on each rod can be used to simulate turnbuckles.
- Trim the deck boards as desired. The under sides, side rails and end pieces can be painted/stained and lettered at this point, or you can choose to do so later if you so choose. I did most of step 16 at this point.
- Install the coupler boxes. I recommend applying some CA to the frame where the coupler boxes will go, followed by appropriate screws (unfortunately, the screws included with some kits are for the trucks and are too long for this application).
- Install the trucks at this time using the screws and insulating fiber washers (some kits). For those unfamiliar, the washers go between the truck and bolster to smoothen truck movement. Tichy Arch Bar trucks (some kits) can now have the spring planks installed. Despite the instructions, I've found that a dab of CA helps keep the spring planks in place. If the

screws don't hold, add a drop or two of CA into the holes and try again.

19. Install the bolts, ladders and stake pockets (optional) using glue. Either CA or white/wood glue seems to work equally well. The bolts and ladders have cut holes where their respective parts fit. There are provisions for 8 stake pockets on each side of the 36 foot car.

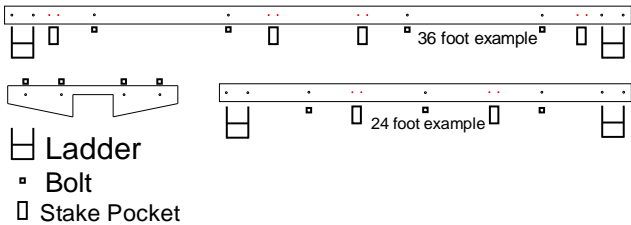

20. For the brake wheel, cut the head off the needle with wire cutters to a height of 4 scale feet (35/64 inch) or as desired. Glue the wheel and rod to the wood piece, sharpened end down and in the notch. I glued mine to the end of the car. Different variations are highly encouraged!

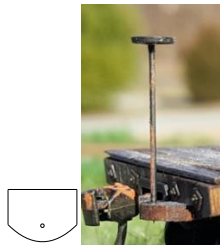

21. For the logging car you have two choices:
- Install the flat pieces on the deck and apply NBWs. The square piece will go directly on the deck, next to where the stake pockets go with the crib pieces inside, facing up.
  - Cut 1/32 pieces of stripwood to approximately 1 inch so that they will fit in the stake pockets.

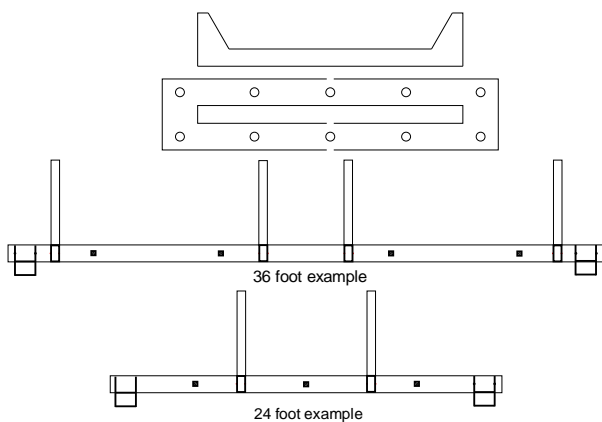

21. For the gondola option (36-Foot version only), follow step 21B, add two additional stake pockets and stripwood on each end. Then, add the scribed wood pieces with the scribed sides facing outward.

Please share your completed photos on <https://www.facebook.com/ConowingoModels/>

See [Conowingomodels.com](http://Conowingomodels.com) for more unique model railroad products.

If there are any parts missing, please e-mail us [conowingomodels@yahoo.com](mailto:conowingomodels@yahoo.com) and we'll get those parts headed your way. We strive for a perfect kit, but mistakes do happen. We apologize if this happens.

Many thanks to Steve Milley, Jeff Grove and Mark Schreier for their help! Additional thanks to Don Tichy for all the parts and diagrams!

Like the design? Want to see this car developed into other things? Please drop us an e-mail and/ or visit the Facebook page to see the latest development with it.

Visit [conowingomodels.com](http://conowingomodels.com) or the Facebook page often to view any newly developed rolling stock.

