



Aerial Work Platforms

Genie® Runabout™



Specifications

Models	GR-12		GR-15		GR-20	
Measurements	US	Metric	US	Metric	US	Metric
Working height*	17 ft 4 in	5.45 m	20 ft 8 in	6.47 m	25 ft 9 in	8.02 m
Platform Maximum Height (Indoor)	11 ft 4 in	3.5 m	14 ft 8 in	4.5 m	19 ft 9 in	6.0 m
Platform Restricted (Outdoor) Height	9 ft 1 in	2.8 m	11 ft 1 in	3.4 m	15 ft 6 in	4.7 m
A B Platform dimensions (length x width)						
Standard	35 x 29.5 in	.89 x .75 m	35 x 29.5 in	.89 x .75 m	35 x 29.5 in	.89 x .75 m
Standard with extension	55 x 29.5 in	1.4 x .75 m	55 x 29.5 in	1.4 x .75 m	55 x 29.5 in	1.4 x .75 m
C Height - stowed	5 ft 10 in	1.78 m	5 ft 10 in	1.78 m	6 ft 6 in	1.98 m
D Length - stowed	4 ft 5 in	1.35 m	4 ft 5 in	1.35 m	4 ft 5 in	1.35 m
E Width	2 ft 5.5 in	.75 m	2 ft 5.5 in	.75 m	2 ft 7.5 in	.80 m
F Ground clearance - center	2.5 in	6 cm	2.5 in	6 cm	2.5 in	6 cm

Productivity

Lift capacity	500 lbs	227 kg	500 lbs	227 kg	350 lbs	159 kg
Lift capacity - extension deck	250 lbs	113 kg	250 lbs	113 kg	250 lbs	113 kg
Drive speed - stowed	2.5 mph	4.0 km/h	2.5 mph	4.0 km/h	2.5 mph	4.0 km/h
Drive speed - raised	0.5 mph	0.8 km/h	0.5 mph	0.8 km/h	0.5 mph	0.8 km/h
Gradeability**	30%		30%		30%	
Turning radius - inside	zero		zero		zero	
Turning radius - outside	4 ft 4 in	1.32 m	4 ft 4 in	1.32 m	4 ft 5 in	1.34 m
Raise / lower speed	20 / 18 sec	20 / 18 sec	21 / 19 sec	21 / 19 sec	24 / 21 sec	24 / 21 sec
Controls	24V DC proportional		24V DC proportional		24V DC proportional	
Tires - solid non-marking	10 x 3 x 8 in	25 x 8 x 20 cm	10 x 3 x 8 in	25 x 8 x 20 cm	10 x 3 x 8 in	25 x 8 x 20 cm
Tilt sensor activation	front to back 3° – side to side 1.5°		front to back 3° – side to side 1.5°		front to back 3° – side to side 1.5°	

Power

Power source	24V (four 6V 225 Ah batteries)		24V (four 6V 225 Ah batteries)		24V (four 6V 225 Ah batteries)	
Hydraulic system capacity	2.2 gal	8.33 L	2.2 gal	8.33 L	2.2 gal	8.33 L

Weight*** / Floor Loading****

Weight - ANSI/CSA	1,681 lbs	763 kg	2,178 lbs	988 kg	2,531 lbs	1,140 kg
Occupied floor pressure	200.87 psf	9.6 kPa	251.99 psf	12.1 kPa	250.39 psf	12.0 kPa

Standards Compliance

ANSI A92.20, CSA B354.6, CE Compliance, AS 1418.10

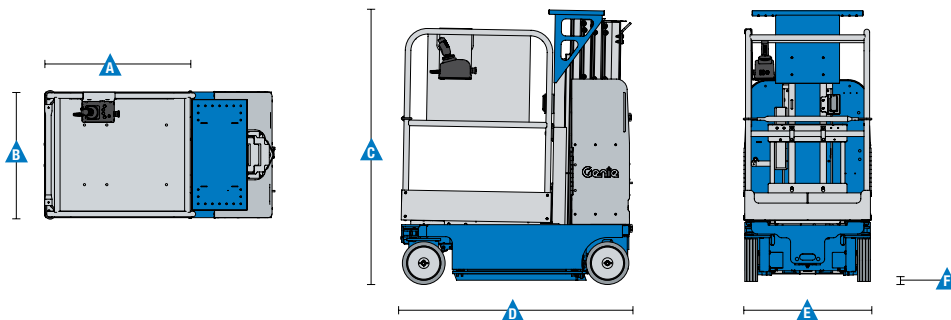

* The metric equivalent of working height adds 2 m to platform height. U.S. adds 6 ft to platform height.

** Gradeability applies to driving on slopes. See operator's manual for details regarding slope rating.

*** Weight will vary depending on options and/or country standards.

**** Note: Floor loading information is approximate and does not incorporate different option configurations. It should be used only with adequate safety factors.

Features

Standard Features

Measurements

GR-12

- 17 ft 4 in (5.45 m) working height
- 11 ft 4 in (3.45 m) platform maximum height (indoor)
- 9 ft 1 in (2.8 m) platform restricted (outdoor) height
- Up to 500 lbs (227 kg) lift capacity

GR-15

- 20 ft 8 in (6.52 m) working height
- 14 ft 8 in (4.52 m) platform maximum height (indoor)
- 11 ft 1 in (3.4 m) platform restricted (outdoor) height
- Up to 500 lbs (227 kg) lift capacity

GR-20

- 25 ft 9 in (8.02 m) working height
- 19 ft 9 in (6.02 m) platform maximum height (indoor)
- 15 ft 6 in (4.7 m) platform restricted (outdoor) height
- Up to 350 lbs (159 kg) lift capacity

Productivity

- Standard platform with sliding midrail
- Auxiliary platform lowering
- Patented rigid mast system
- Compact base 29.5 x 53 in (.75 m x 1.35 m) (GR™-12, GR™-15 only)
- Ground clearance 2.5 inches (stowed)
- SmartLink™ dual zone control system
- Battery charge indicator
- On-board diagnostic system
- AC power to platform
- Descent and tilt alarm
- Zero inside turning radius
- Dual wheel brakes
- Hydraulic brake release
- Pothole protection

Standard Features

Productivity (continued)

- Hinged rear ABS covers for easy access to all major electrical and hydraulic components
- Tie down attachment points
- Overhead crane attachment point
- Large forklift pockets access
- Non-marking solid tires
- Motion alarm
- Dual LED flashing beacons
- Proportional drive and lift
- Load sense
- Platform control guard
- Tech Pro Link connector

Power

- Automatic 19 amp battery charger

Options & Accessories

Productivity

- 20 in (.51 m) extension platform with sliding midrail
- 20 in (.51 m) extension platform with gate
- Lift Guard™ Contact Alarm
- Platform control guard
- Fluorescent tube caddy**
- Automotive horn
- EE Certification*
- Biodegradable hydraulic oil
- Drive cutout while charging
- 10 ft retractable charging cord*
- Lift Tools™ Work Tray

Power

- 24V (four 6V 225 Ah batteries)
- 800 watt, 24 V inverter (120-230V AC/50-60 Hz)
- AGM maintenance-free batteries



* Not available with automotive horn or inverter
** Not available with EE certification

Genie United States

6464 185th Ave. NE
Redmond, WA 98052
Telephone +1 (425) 881-1800
Toll Free in USA/Canada +1 (800)-536-1800
Fax +1 (425) 883-3475

Distributed By: Boland Equipment Rentals

www.berequipment.com
201-342-8020



Effective Date: October, 2019. Product specifications and prices are subject to change without notice or obligation. The photographs and/or drawings in this document are for illustrative purposes only. Refer to the appropriate Operator's Manual for instructions on the proper use of this equipment. Failure to follow the appropriate Operator's Manual when using our equipment or to otherwise act irresponsibly may result in serious injury or death. The only warranty applicable to our equipment is the standard written warranty applicable to the particular product and sale and we make no other warranty, express or implied. Products and services listed may be trademarks, service marks or trade names of Terex Corporation and/or their subsidiaries in the USA and many other countries. Terex, Genie and AWP are registered trademarks of Terex Corporation or its subsidiaries. © 2019 Terex Corporation.