

S3220E/S3226E

ELECTRIC SLAB SCISSOR LIFTS



- Self-propelled electric scissor lifts
- Compact & nimble
- Roll-out extension decks for extra reach
- Suitable for indoor and outdoor use
- Ideal for construction & maintenance applications

 **snorkel**[™]
www.snorkellifts.com

ELECTRIC SLAB SCISSOR LIFTS

S3220E/S3226E

DIMENSIONS	S3220E	S3226E
Max. working height	26 ft	32 ft
Max. platform height (A)	20 ft	26 ft
Platform size (stowed)	28.25 in x 84.38 in	28.25 in x 84.38 in
Platform size (extended)	28.25 in x 102.38 in	28.25 in x 102.38 in
Deck extension length (B)	36 in	36 in
Overall length (D) (with step)	90.6 in	90.6 in
Overall length (D) (step removed)	88.75 in	88.75 in
Overall width (C)	32 in	32 in
Stowed height (E)	85.25 in	90.5 in
Min. height (guard rails folded)	67.75 in	73.13 in
Ground clearance (stowed)	3.75 in	3.75 in
Ground clearance (elevated)	0.75 in	0.75 in

PERFORMANCE		
Platform capacity	900 lbs	500 lbs
Max. wind speed	28 mph	28 mph
Max. drive height	20 ft	26 ft
Max. drive speed (stowed)	2.0 mph	2.0 mph
Max. drive speed (elevated)	0.4 mph	0.4 mph
Raise/lower time	34/43 sec	50/56 sec
Gradeability	25%	25%
Inside turning radius	30 in	30 in
Outside turning radius	93 in	93 in
Tires	15 x 4 non-marking rubber	
Controls	proportional	
Drive system	2 wheel drive	

POWER		
Power source	24V DC battery electric	
Charger	90-240V, 25amp	

WEIGHT		
Weight	4,500 lbs	4,900 lbs

TURNING RADIUS

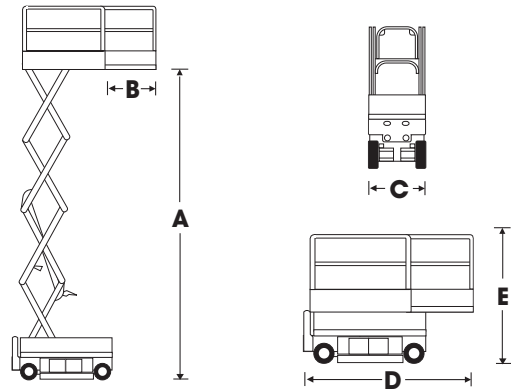
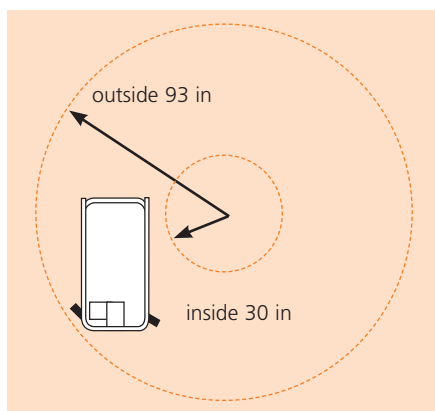

STANDARD FEATURES

- Roll-out deck extension with dual locks
- Non-marking tires
- Swing-out service trays
- Saloon-door style entry gates
- Descent alarm
- All motion alarm
- Proportional controls, including descent
- 2 persons indoor
- 1 person outdoor
- Loading pendant
- Power line to platform
- Platform overload system (S3226E)
- Hour meter & on-board diagnostics display
- Flashing amber light (S3226E)
- Integrated battery charger
- Battery condition indicator
- Crane & forklift points
- Dual lanyard attachment points
- Scissor stack roller slide plates (set of 2)
- 2 year parts & labor, 5 year structural warranty
- ANSI compliant

OPTIONS

- Special paint colors
- Flashing amber light
- 110V AC 800W inverter
- Airline to platform
- Aircraft bumpguard package
- Environmental hydraulic oil
- Snorkel Guard™ secondary guarding system
- Panel carrier
- Top rail

snorkel

www.snorkellifts.com

P.O. Box 1160
 St. Joseph, MO 64502-1160, USA
 Tel: 1 (785) 989-3000
 Toll-free: 1 (800) 255-0317
 Fax: 1 (785) 989-3070
 Email: sales.usa@snorkellifts.com