

# S4740E

## ELECTRIC SLAB SCISSOR LIFT



- Self-propelled electric scissor lift
- Choice of electric or hydraulic drive
- Roll-out deck extension for extra reach
- Suitable for indoor and outdoor use
- Ideal for construction & maintenance applications



Boland Equipment Rentals  
[www.berequipment.com](http://www.berequipment.com)  
201-342-8020

# ELECTRIC SLAB SCISSOR LIFT

# S4740E

DIMENSIONS	S4740E*
Max. working height	45 ft 5 in
Max. platform height (A)	39 ft 5 in
Platform size (stowed)	43 in x 84 in
Platform size (extended)	43 in x 132 in
Deck extension length (B)	48 in
Overall length (D) (with step)	90.6 in
Overall length (D) (step removed)	89 in
Overall width (C)	47 in
Stowed height (E)	101 in
Min. height (guardrails folded)	76 in
Ground clearance (stowed)	2.63 in
Ground clearance (elevated)	0.75 in

PERFORMANCE	
Platform capacity	550 lbs
Max. wind speed	28 mph
Max. drive height	39 ft 5 in
Max. drive speed (stowed)	2.0 mph
Max. drive speed (elevated)	0.4 mph
Raise/lower time	68/72 sec
Gradeability	25%
Inside turning radius	21 in
Outside turning radius	95 in
Tires	15 x 5 non-marking rubber
Controls	proportional
Drive system	2 wheel drive

POWER	
Power source	24V DC battery electric
Charger	90 - 240V, 25amp

WEIGHT	
Weight	6,825 lbs

## TURNING RADIUS

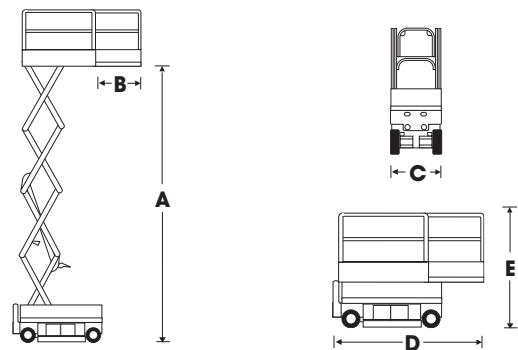
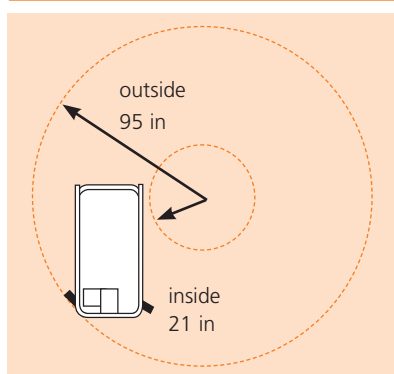

## STANDARD FEATURES

- Hydraulic drive
- Roll-out deck extension with dual locks
- Non-marking tires
- Swing-out service trays
- Saloon-door style entry gates
- Descent alarm
- All motion alarm
- 2 persons indoor
- 1 person outdoor
- Proportional controls, including descent
- Power line to platform
- Loading pendant
- Hour meter & onboard diagnostics display
- Integrated battery charger
- Battery condition indicator
- Crane & forklift points
- Dual lanyard attachment points
- Scissor stack roller slide plates (set of 2)
- 2 year parts & labor, 5 year structural warranty
- ANSI compliant

## OPTIONS

- Special paint colors
- Electric drive
- Flashing amber light
- 110V AC 800W inverter
- Airline to platform
- Aircraft bumpguard package
- Environmental hydraulic oil
- Snorkel Guard™ secondary guarding system



282 Hudson Street  
Hackensack, NJ 07601

O: 201-342-8020

[www.berequipment.com](http://www.berequipment.com)